



Dingo[®] 420 TX
Compact Utility Loader
Model No. 22306—230000301 and Up

Parts Catalog

Ordering Replacement Parts

To order replacement parts, please supply: the part number, the quantity, and the description of each part desired.

Understanding Reference Numbers

Each identified part in an illustration has a reference number. The reference number for a part also appears in the parts list, along with other information about the part.

This catalog uses two special reference number formats, one to indicate parts in a service assembly and another to indicate the quantity of a given part in an illustration.

Service Assembly Reference Numbers

Parts in service assemblies have reference numbers in the form **a:b**. The **a** represents the reference number of the entire service assembly and the **b** represents a sequential number unique to each part within the service assembly.

For example, a wheel assembly might be identified by reference number **6**, the tire by **6:1**, the valve by **6:2**, and the wheel by **6:3**. When you order the assembly identified by reference number **6**, you receive all parts identified by reference numbers **6:1**, **6:2**, and **6:3**. However, you may also order any part individually.

Reference numbers of this type appear in illustrations and in part lists.

Reference Numbers Indicating Quantity

In an illustration, if a reference number indicates more than one part, the reference number has the form **nX y**. The **n** represents the quantity of the part, the **X** is the multiplication symbol, and the **y** represents the reference number.

For example, in an illustration, the reference number **2X 37** means that two of the parts identified by reference number **37** are indicated.

Contents

Description	Page	Description	Page
Main Frame and Fuel Tank Assembly	4	Rear Access Panel Assembly	33
Track and Traction Assembly	5	Electrical Schematic	34
Brake Assembly	6	Hydraulic Schematic	35
Loader Tower and Drive Assembly	7	Group 1 – Crankshaft Assembly	
Traction Hydraulic Assembly	8	Kohler CH20S-64656	36
Hydraulic Wheel Motor Assembly No. 98-2767	10	Group 2 – Crankcase Assembly	
Hydraulic Pump		Kohler CH20S-64656	37
Assembly No. 98-8432 and 98-8431	11	Group 3 – Oil Pan/Lubrication Assembly	
Engine Assembly	12	Kohler CH20S-64656	38
Hydraulic Pump Assembly	13	Group 4 – Head/Valve/Breather Assembly	
Hydraulic Gear Pump Assembly No. 98-2752 .	15	Kohler CH20S-64656	39
Control Panel Assembly	16	Group 5 – Ignition/Electrical Assembly	
Traction Control Assembly	18	Kohler CH20S-64656	40
Principal Hydraulic Assembly	19	Group 6 – Blower Housing Assembly	
Two Spool Valve Assembly No. 95-3536	21	Kohler CH20S-64656	41
One Spool Valve Assembly No. 104-2831	22	Group 7 – Starter Assembly	
Loader Arm Assembly	23	Kohler CH20S-64656	42
Loader Arm Hydraulic Assembly	24	Group 8 – Fuel System Assembly	
Hydraulic Cylinder Assembly No. 99-6162	26	Kohler CH20S-64656	43
Hydraulic Cylinder Assembly No. 95-3578	27	Group 9 – Engine Control Assembly	
Quick Attach Assembly	28	Kohler CH20S-64656	44
Electrical Assembly	29	Group 10 – Air Intake/Filtration Assembly	
Grill Assembly	30	Kohler CH20S-64656	45
Hydraulic Cooler Assembly	31	Group 11 – Exhaust Assembly	
Hood Assembly	32	Kohler CH20S-64656	46

Accessories

Description	Model / Part No.	Description	Model / Part No.
Dingo TX Heat Shield Kit	104-9997	Dingo TX CE Kit	22350

Part Description Abbreviations

Part descriptions in this catalog may include the following abbreviations.

Abbreviation	Meaning	Abbreviation	Meaning
AR	as required	HYD	hydraulic
ASM	assembly	INC	incorporated
CARR	carriage	LH	left hand
DEG	degrees	NI	nylon insert
FH	flat head	PPH	Phillips pan head
GA	gauge	PTH	Phillips truss head
HF	hex flange	PTO	power take off
HH	hex head	RH	right hand
HHF	hex head flange	SFH	slotted fillister head
HLH	hex lag head	SHH	slotted hex head
HJ	hex jam	SQH	square head
HOC	height-of-cut	SHWH	slotted hex washer head
HS	hex socket	SPH	slotted pan head
HSBH	hex socket button head	SRH	slotted round head
HSFH	hex socket flat head	STD	standard
HSH	hex socket head	TAP	self tapping
HWH	hex washer head	TTH	Torx truss head
HWHTF	hex washer head thread forming	WH	wing head

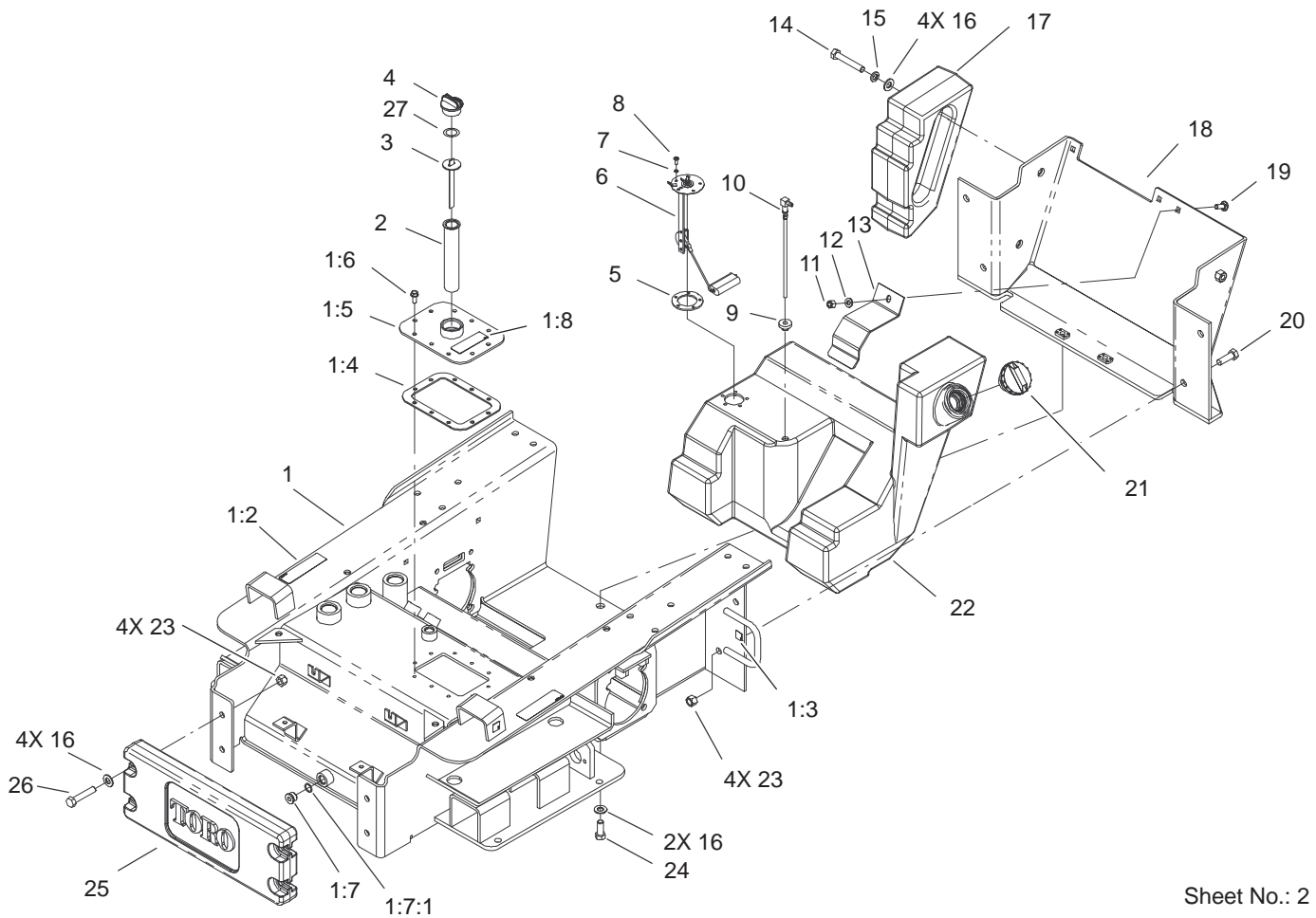

Sheet No.: 2

Main Frame and Fuel Tank Assembly

Ref. No.	Part No.	Qty.	Description
1	105-5830	1	Chassis ASM
1:2	100-6141	2	Decal-Pinch
1:3	93-9084	4	Decal-Point, Lift
1:4	100-1253	1	Gasket-Cover, Access
1:5	104-8389-01	1	Tank Cover ASM
1:6	98-9940	10	Screw
1:7	353-988	2	Plug-Hex, Hollow
1:7:1	237-79	1	O-Ring
1:8	105-8432	1	Decal-Oil, Hydraulic
2	61-2790	1	Filter-Screen
3	100-2097	1	Dipstick-Oil
4	93-7498	1	Plug-Plastic
5	113372	1	Gasket-Sender, Fuel
6	100-1298	1	Sender-Fuel
7	3253-17	5	Washer-Lock/Sp
8	3250-31	5	Screw-PPH
9	46-6560	1	Bushing
10	98-0185	1	Pipe Stand ASM
11	3296-39	1	Nut-Lock, NI
12	3256-38	1	Washer-Flat
13	100-1257-03	1	Clamp-Tank, Fuel
14	325-12	4	Screw-HH
15	3253-7	4	Washer-Lock
16	3256-26	10	Washer-Flat
17	99-6165-01	2	Counterweight-Rear

Ref. No.	Part No.	Qty.	Description
18	105-0373-01	1	Rear Frame Cover ASM
19	3231-22	1	Screw-CARR
20	325-6	4	Screw-HH
21	93-3101	1	Cap-Fuel
22	95-3619	1	Tank-Fuel
23	3296-23	8	Nut-Lock, NI
24	325-5	2	Screw-HH
25	99-6166-01	1	Counterweight-Front
26	325-10	4	Screw-HH
27	327-123	1	O-Ring

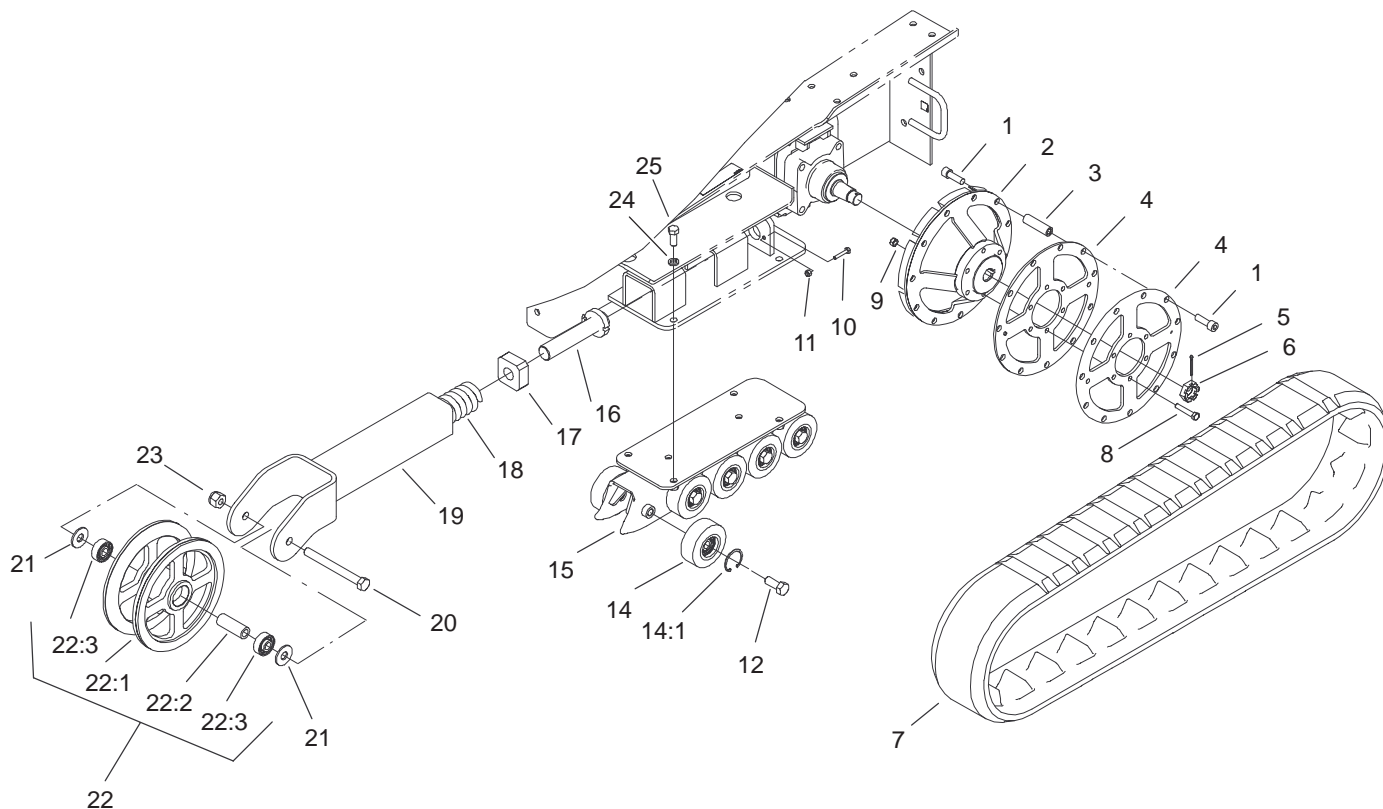

Sheet No.: 3

Track and Traction Assembly

Ref. No.	Part No.	Qty.	Description
1	3274-4	44	Screw-HSH
2	106-7600-03	2	Drive Wheel ASM
3	100-1286	22	Spacer-Wheel, Drive
4	99-6159-03	4	Plate-Wheel, Drive
5	3272-12	2	Pin-Cotter
6	99-3139	2	Nut
7	98-9800	2	Track
8	323-10	12	Screw-HH
9	32153-2	12	Nut-Lock, Side-Deform
10	321-13	2	Screw-HH
11	3296-42	2	Nut-Lock, NI
12	327-4	20	Screw-HH
14	99-6154	20	Bogey Wheel ASM
14:1	32120-62	1	Ring-Retaining
15	105-5803-03	2	Track Guide ASM
16	98-9846	2	Bolt-Tensioner
17	95-3626	2	Block-Tensioning
18	95-3624	2	Spring-Compression
19	98-9801-03	2	Tensioner Arm ASM
20	327-17	2	Screw-HH
21	3256-7	4	Washer-Flat
22	104-5745	2	Tensioner Wheel ASM
22:1	104-5747-03	1	Wheel-Tensioner
22:2	98-9835	1	Spacer-Wheel, Tensioner

Ref. No.	Part No.	Qty.	Description
22:3	93-4237	2	Bearing
23	3296-24	2	Nut-Lock NI
24	3253-7	8	Washer-Lock
25	325-5	8	Screw-HH

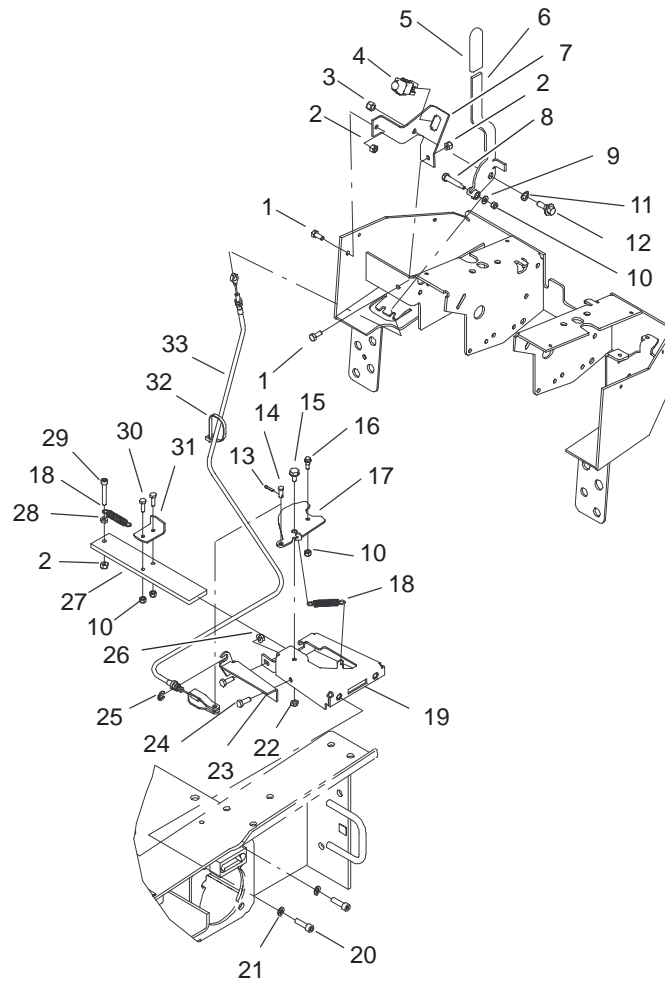

Sheet No.: 5

Brake Assembly

Ref. No.	Part No.	Qty.	Description
1	322-3	2	Screw-HH
2	3296-29	4	Nut-Lock, NI
3	3296-6	1	Nut-Lock, NI
4	100-1268	1	Switch-Plunger
5	62-9130	1	Grip-Handle
6	99-6151-03	1	Brake Lever ASM
7	105-5809-03	1	Bracket-Switch
8	611792	1	Bolt-Shoulder
9	3256-22	1	Washer-Flat
10	3296-42	7	Nut-Lock, NI
11	3290-221	1	Washer-Spring
12	93-2364	1	Bolt-Shoulder
13	3272-9	2	Pin-Cotter
14	283-62	2	Pin-Clevis
15	37-8771	2	Bolt-Shoulder
16	42-3560	2	Bolt-Shoulder
17	98-8443	2	Lever-Brake
18	87-4020	4	Spring-Extension
19	100-4200-03	2	Brake Housing ASM
20	3274-1	4	Screw-HSH
21	3253-5	4	Washer-Lock
22	3296-47	2	Nut-Lock, NI
23	98-8446-03	2	Bracket-Cable, Brake
24	322-4	4	Screw-HH
25	32151-43	2	Ring-Clip
26	32128-20	4	Nut-HF

Ref. No.	Part No.	Qty.	Description
27	106-7550-03	2	Plate-Brake
28	3218-2	2	Nut-Jam
29	3274-86	2	Screw-HSH
30	321-5	4	Screw-HH
31	98-8448	2	Stop-Brake
32	3290-378	2	Tie-Cable
33	100-1283	2	Cable-Brake

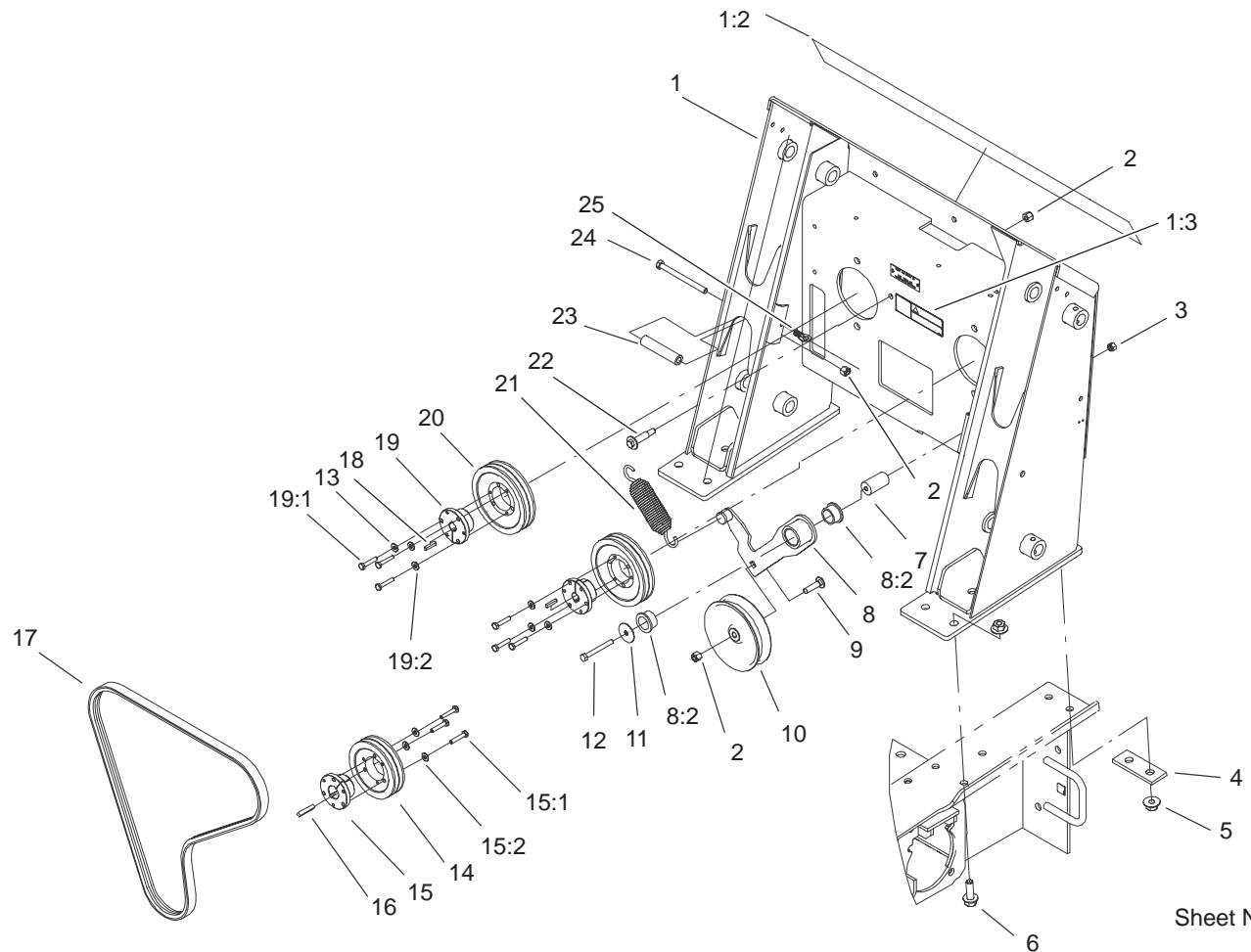

Sheet No.: 6

Loader Tower and Drive Assembly

Ref. No.	Part No.	Qty.	Description	Ref. No.	Part No.	Qty.	Description
1	104-2843	1	Loader Tower ASM	20	100-4207	2	Sheave
1:2	104-2842	1	Decal-Panel	21	105-0383	1	Spring-Extension
1:3	80-8040	1	Decal-Warning	22	56-6590	1	Bolt-Wheel
2	3296-39	4	Nut-Lock, NI	23	100-1271	2	Tube-Spacer
3	3296-29	1	Nut-Lock, NI	24	323-23	2	Screw-HH
4	100-6123-01	2	Plate-Stiffener	25	95-4013	2	Latch ASM
5	32128-52	10	Locknut-Flange				
6	100-6116	10	Screw-HHF				
7	104-5739	1	Spacer-Mounting				
8	99-6167	1	Idler Arm ASM				
8:2	256-132	2	Bushing-Flange				
9	3231-26	1	Screw-CARR				
10	95-3707	1	Pulley-Idler				
11	3256-68	1	Washer-Flat				
12	322-13	1	Screw-HH				
13	3256-22	9	Washer-Flat				
14	61-3330	1	Pulley				
15	61-3340	1	Bushing				
15:1	100-4208	3	Screw-HH				
15:2	100-4209	3	Washer-Lock/Sp				
16	67-7490	1	Key				
17	95-3611	1	V-Belt				
18	80-6090	2	Key-Pump				
19	100-4206	2	Bushing				
19:1	100-4208	3	Screw-HH				
19:2	100-4209	3	Washer-Lock/Sp				

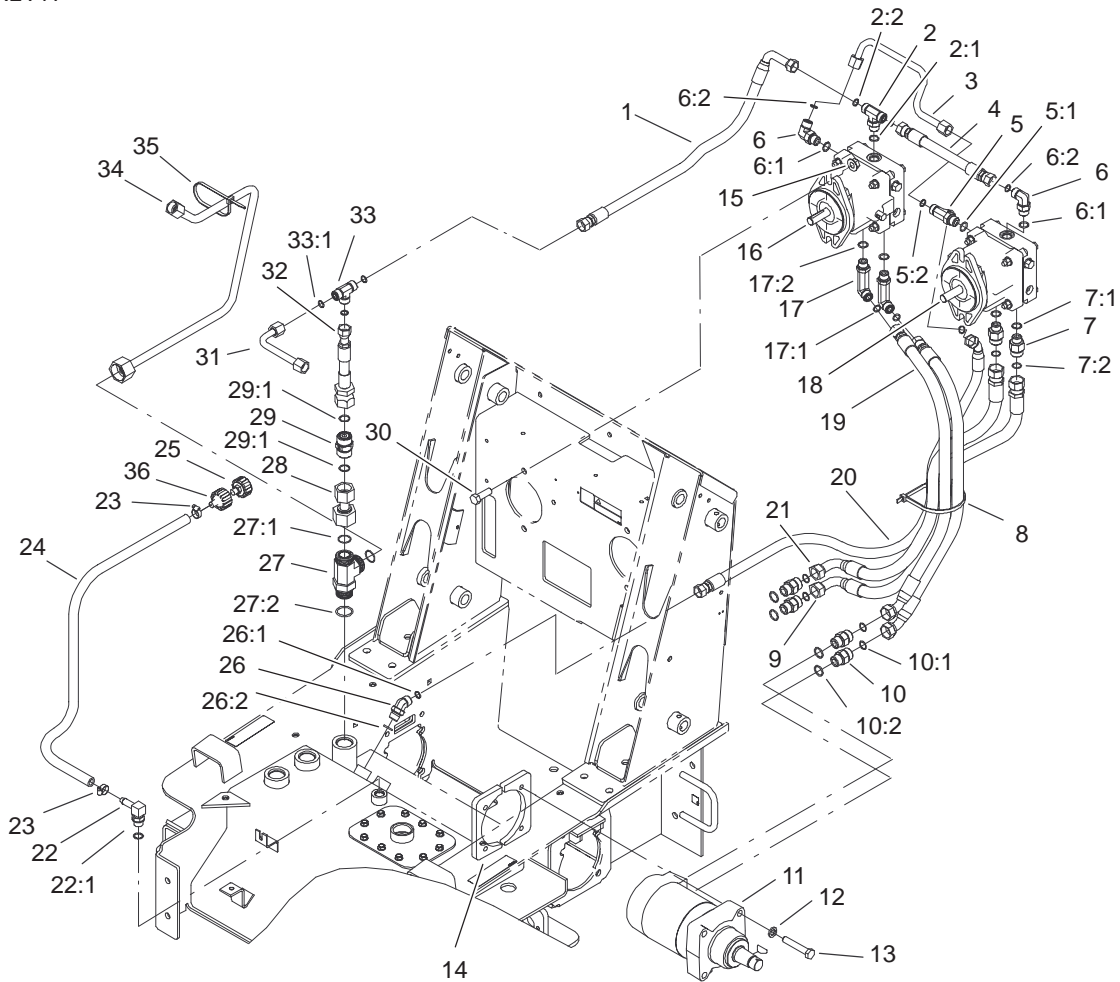

Sheet No.: 7

Traction Hydraulic Assembly

Ref. No.	Part No.	Qty.	Description
1	100-6130	1	HYD Hose ASM
2	340-157	1	Fitting-HYD
2:1	237-79	1	O-Ring
2:2	237-30	2	O-Ring
3	98-0200	1	HYD Tube ASM
4	95-3664	1	HYD Hose ASM
5	340-109	1	Fitting-HYD, Tee
5:1	237-79	1	O-Ring
5:2	237-30	2	O-Ring
6	340-98	2	Fitting-HYD, 90°
6:1	237-79	1	O-Ring
6:2	237-30	1	O-Ring
7	340-155	2	Fitting-HYD
7:1	237-79	1	O-Ring
7:2	237-151	1	O-Ring
8	3334-945	1	Tie-Cable
9	98-0235	1	HYD Hose ASM
10	340-7	4	Adapter
10:1	237-65	1	O-Ring
10:2	237-80	1	O-Ring
11	98-2767	2	Motor-Wheel, HYD
12	3253-7	8	Washer-Lock
13	325-11	8	Screw-HH
14	98-2763-03	4	Plate-Mounting, Wheelmotor
15	32128-23	4	Nut-HF

Ref. No.	Part No.	Qty.	Description
16	98-8431	1	Pump-HYD, RH
17	99-6160	2	Fitting-Elbow, 90°
17:1	237-30	1	O-Ring
17:2	237-79	1	O-Ring
18	98-8432	1	Pump-HYD, LH
19	98-0233	2	HYD Hose ASM
20	98-0201	1	HYD Hose ASM
21	98-0177	1	HYD Hose ASM
22	354-120	1	Fitting-HYD, 90°
22:1	237-79	1	O-Ring
23	2412-36	2	Clamp-Hose
24	98-2708	1	Hose-Vent
25	68-6150	1	Breather
26	340-101	1	Fitting-HYD, 90°
26:1	237-30	1	O-Ring
26:2	237-79	1	O-Ring
27	104-3795	1	Fitting-Tee, HYD
27:1	340-65	2	O-Ring
27:2	237-146	1	O-Ring
28	105-0226	1	HYD Tube ASM
29	99-6161	1	Valve-Check, HYD
29:1	237-58	2	O-Ring
30	325-6	4	Screw-HH
31	95-3517	1	HYD Tube ASM
32	105-0225	1	HYD Hose ASM
33	340-102	1	Adapter

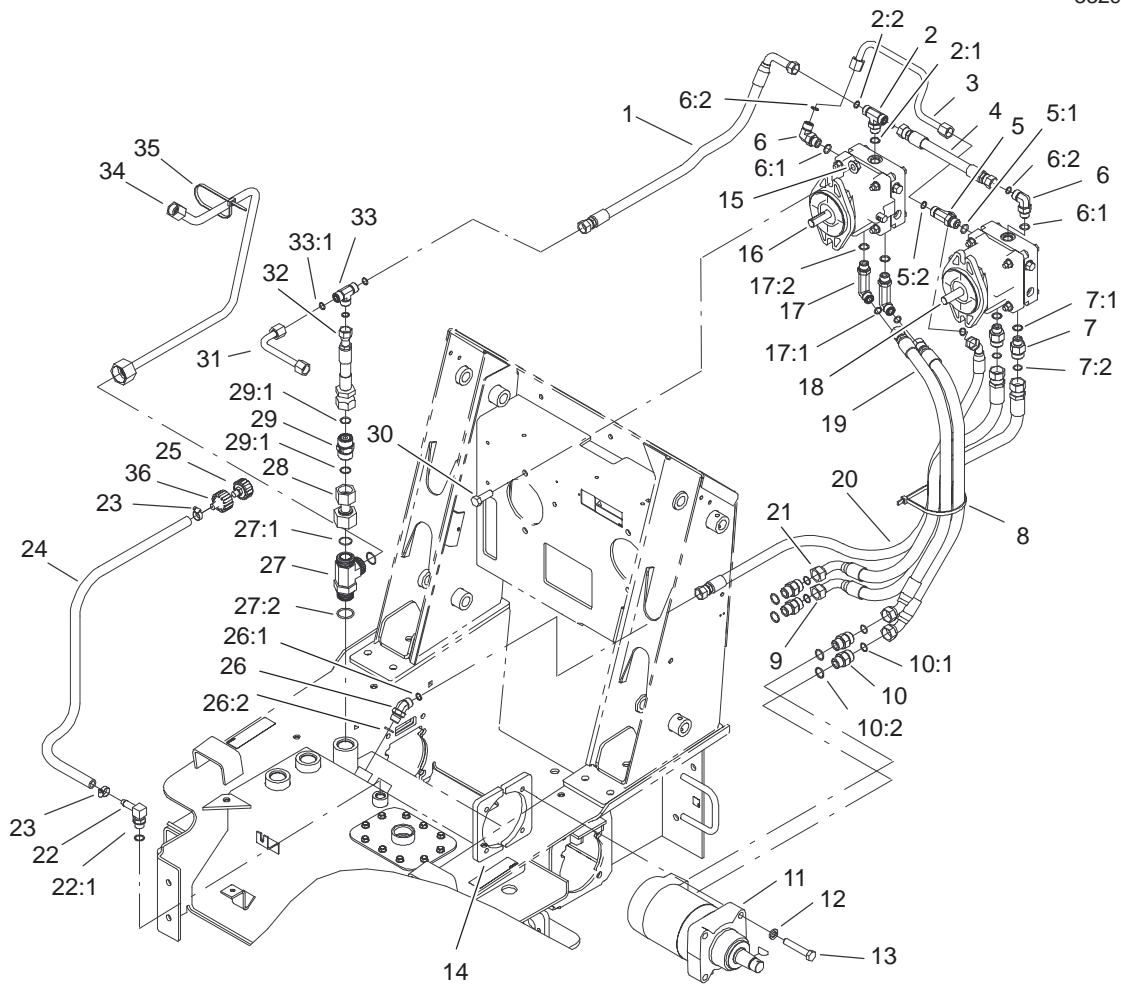

Sheet No.: 7

Traction Hydraulic Assembly (Continued)

Ref. No.	Part No.	Qty.	Description
33:1	237-30	3	O-Ring
34	104-5706	1	HYD Tube ASM
35	3290-378	1	Tie-Cable
36	92-8020	1	Adapter-Breather

Ref. No.	Part No.	Qty.	Description

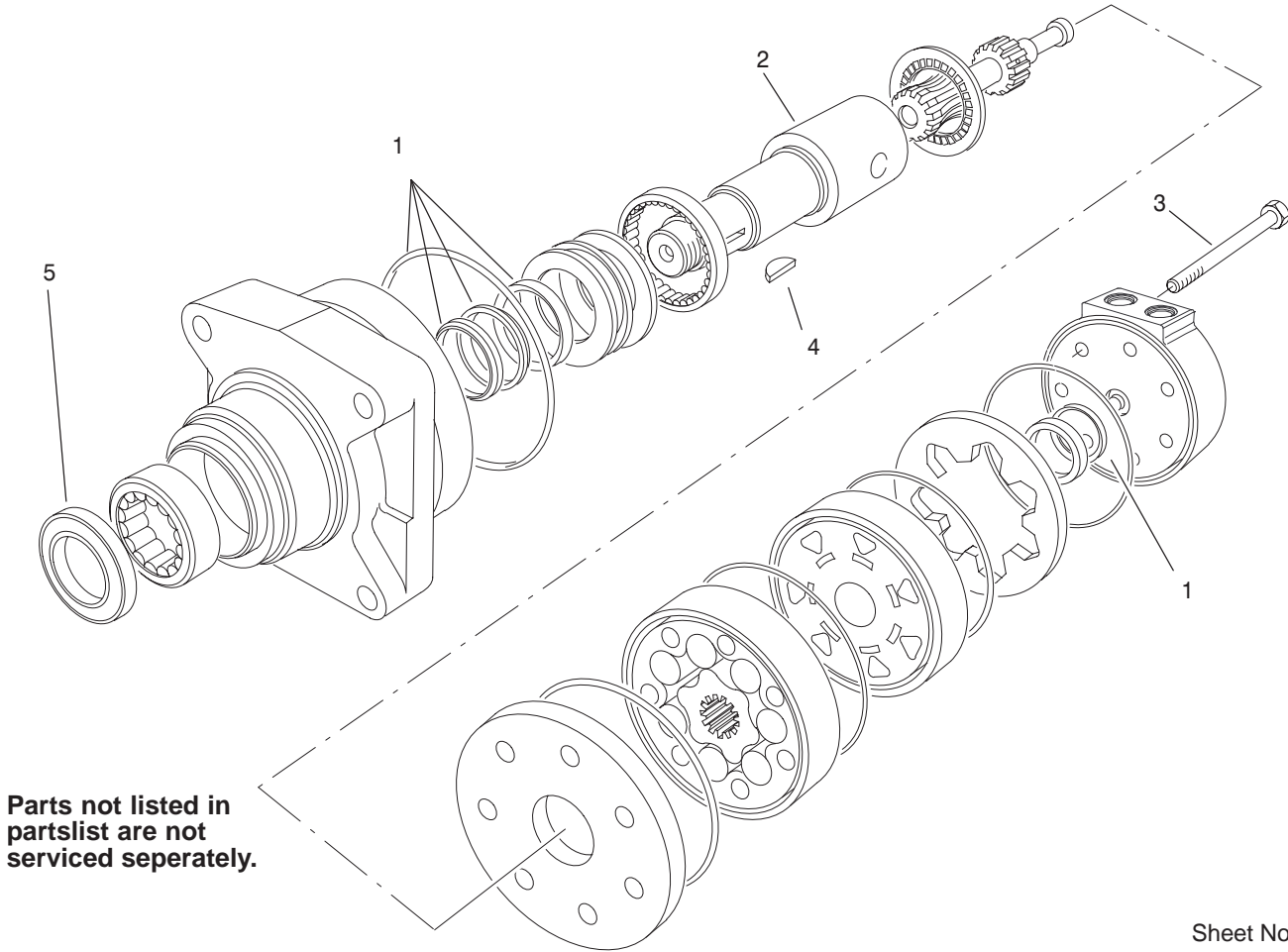

Sheet No.: A1
t-3620

Hydraulic Wheel Motor Assembly No. 98-2767

Ref. No.	Part No.	Qty.	Description
1	100-6131	1	Seal Kit
2	99-3090	1	Coupling-Shaft
3	100-4241	7	Screw-HH
4	3257-42	1	Key-Woodruff

Ref. No.	Part No.	Qty.	Description

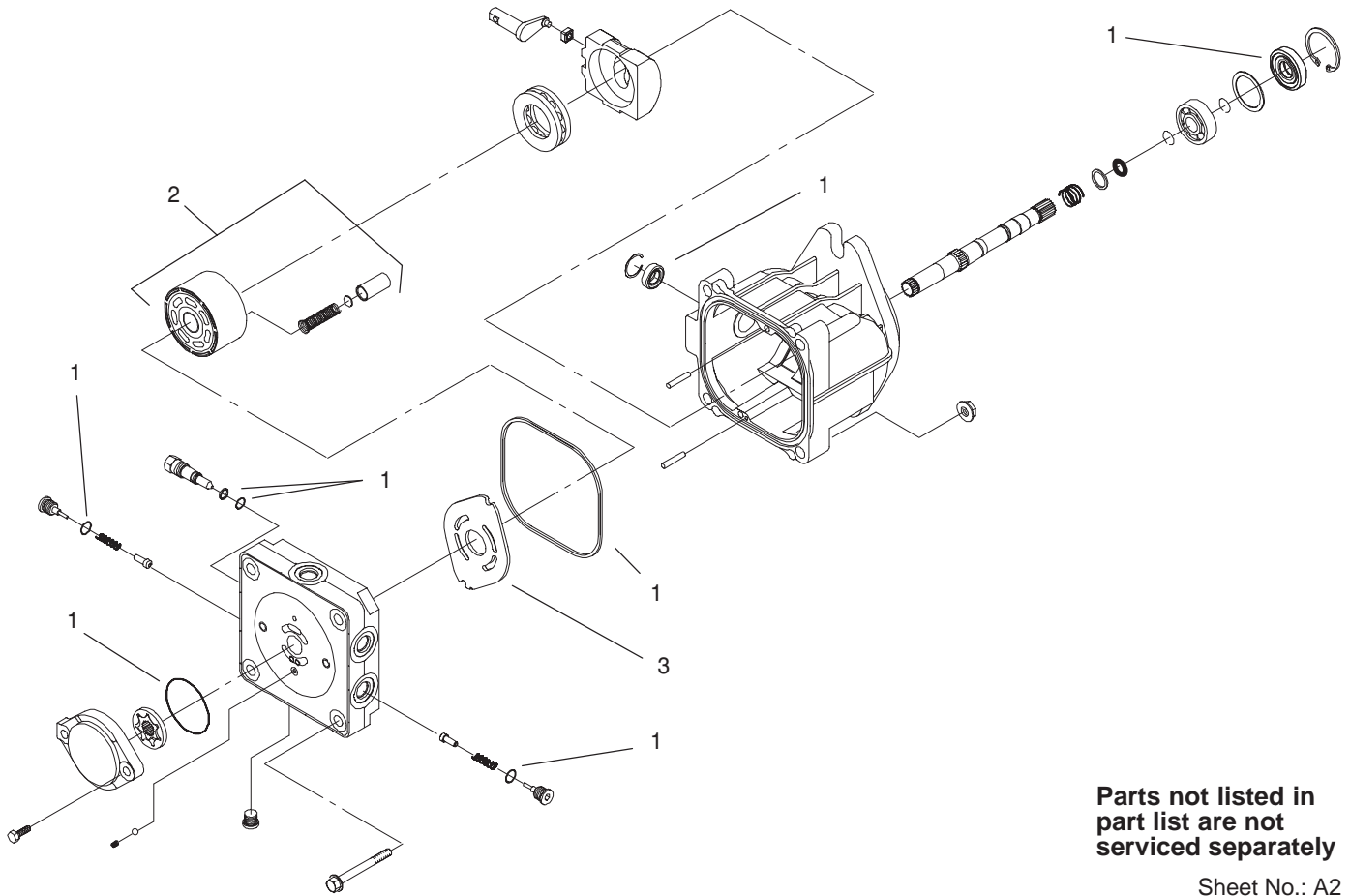

Parts not listed in part list are not serviced separately

Sheet No.: A2
C-3617

Hydraulic Pump Assembly No. 98-8432 and 98-8431

Ref. No.	Part No.	Qty.	Description
1	100-6110	1	Overhaul Seal Kit
2	94-1913	1	Cylinder Block ASM
3	100-6112	1	Plate-Valve

Ref. No.	Part No.	Qty.	Description

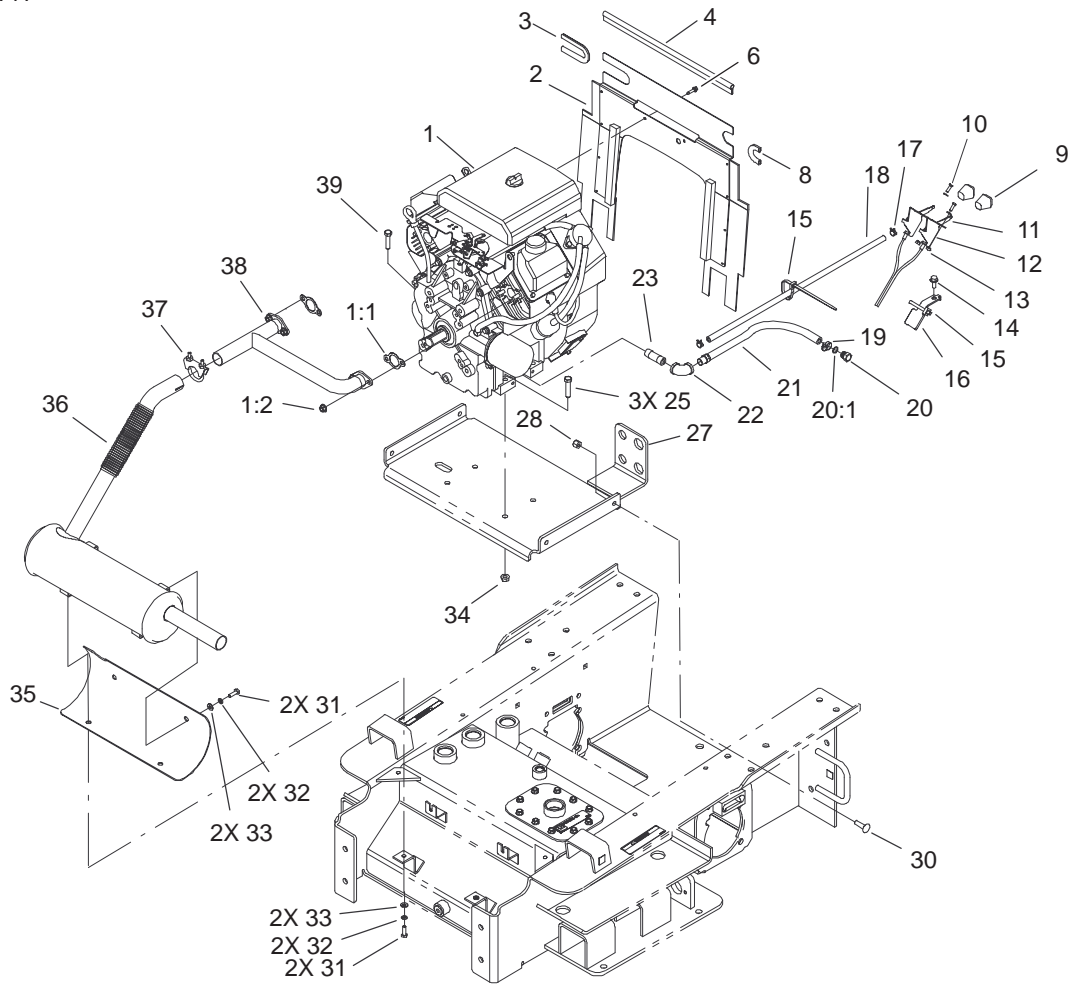

Sheet No.: 8

Engine Assembly

Ref. No.	Part No.	Qty.	Description
☆1		1	Engine-Kohler, Ch20s-64656
1:1	93-0350	2	Gasket-Exhaust
1:2	92-6780	4	Nut-HF
2	106-5748	1	Engine Baffle ASM
3	105-0378	1	Seal-Strip, 6.5"
4	106-5749	1	Seal-Strip, 16"
6	27-0220	2	Screw-Special
8	105-0377	1	Seal-Strip, 3"
9	66-0120	2	Knob
10	3290-134	4	Screw
11	3256-21	4	Washer-Flat
12	99-6173	2	Cable-Throttle
13	3296-2	4	Nut-Lock
14	32144-70	1	Screw-HH
15	3290-378	2	Tie-Cable
16	100-1299-03	1	Guide-Cable
17	2412-98	2	Clamp
18	105-0376	1	Hose-Fuel
19	2412-119	1	Clamp-Worm
20	353-508	1	Plug
20:1	237-42	1	O-Ring
21	100-1256	1	Oil Hose ASM
22	94-9650	1	Elbow-90°
23	289-42	1	Nipple
25	323-9	3	Screw-HH

Ref. No.	Part No.	Qty.	Description
27	99-6175-03	1	Engine Mounting Plate ASM
28	3296-39	4	Nut-Lock, NI
30	3231-28	4	Screw-CARR
31	321-5	4	Screw-HH
32	3253-3	4	Washer-Lock
33	3256-22	4	Washer-Flat
34	32128-21	4	Nut-HF
35	98-2762	1	Shield-Heat, Muffler
36	105-0249	1	Muffler
37	2112-11	1	Clamp-Muffler
38	98-2761	1	Manifold-Crossover
39	323-8	1	Screw-HH

☆ Not serviced separately

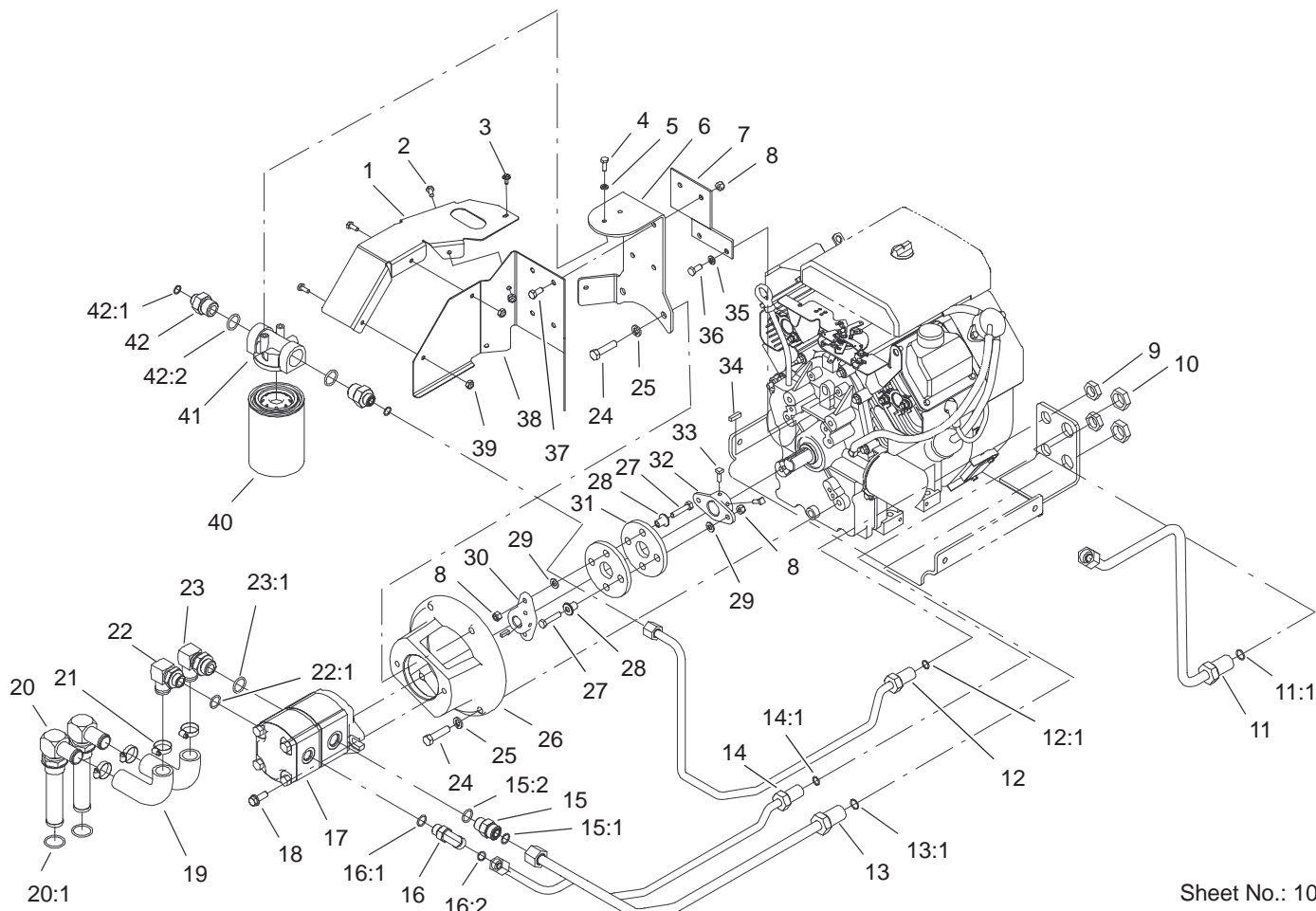

Sheet No.: 10

Hydraulic Pump Assembly

Ref. No.	Part No.	Qty.	Description
1	104-9960	1	Shield-Heat
2	321-39	4	Screw-HH
3	12-5450	1	Screw
4	321-4	2	Screw-HH
5	3253-3	2	Washer-Lock
6	99-6172-03	1	Bracket-Support, Oil Filter
7	99-6171-03	1	Bracket-Support, Oil Filter
8	3296-29	8	Nut-Lock, NI
9	340-127	2	Nut-Bulkhead
10	340-74	2	Locknut-Bulkhead
11	104-5705	1	HYD Tube ASM
11:1	237-65	1	O-Ring
12	98-2780	1	HYD Tube ASM
12:1	237-30	1	O-Ring
13	98-2783	1	HYD Tube ASM
13:1	237-65	1	O-Ring
14	98-2781	1	HYD Tube ASM
14:1	237-30	1	O-Ring
15	340-7	1	Adapter
15:1	237-65	1	O-Ring
15:2	237-80	1	O-Ring
16	340-98	1	Fitting-HYD, 90°
16:1	237-79	1	O-Ring
16:2	237-30	1	O-Ring

Ref. No.	Part No.	Qty.	Description
17	98-2752	1	Pump-Gear, HYD
18	66-9300	2	Screw-HF
19	105-0201	2	Hose-Suction, Formed
20	105-0204	2	Strainer Fitting ASM
20:1	237-146	1	O-Ring
21	2412-34	4	Clamp-Hose
22	61-2710	1	Stem-Hose, 90°
22:1	237-117	1	O-Ring
23	100-4202	1	Fitting-90°
23:1	237-81	1	O-Ring
24	324-7	4	Screw-HH
25	3253-6	4	Washer-Lock
26	98-2751	1	Mount-Pump
27	322-7	4	Screw-HH
28	71-4411	4	Spacer
29	3256-23	4	Washer-Flat
30	49-9600	1	Hub-Pump
31	44-2230	2	Coupling-Rubber
32	27-1960	1	Hub-Engine
33	3241-6	4	Screw-SQH
34	10-7070	1	Key-Square
35	3253-4	2	Washer-Lock
36	33114-020	2	Screw-HH
37	322-3	4	Screw-HH
38	100-6114	1	Shield-Heat, Filter

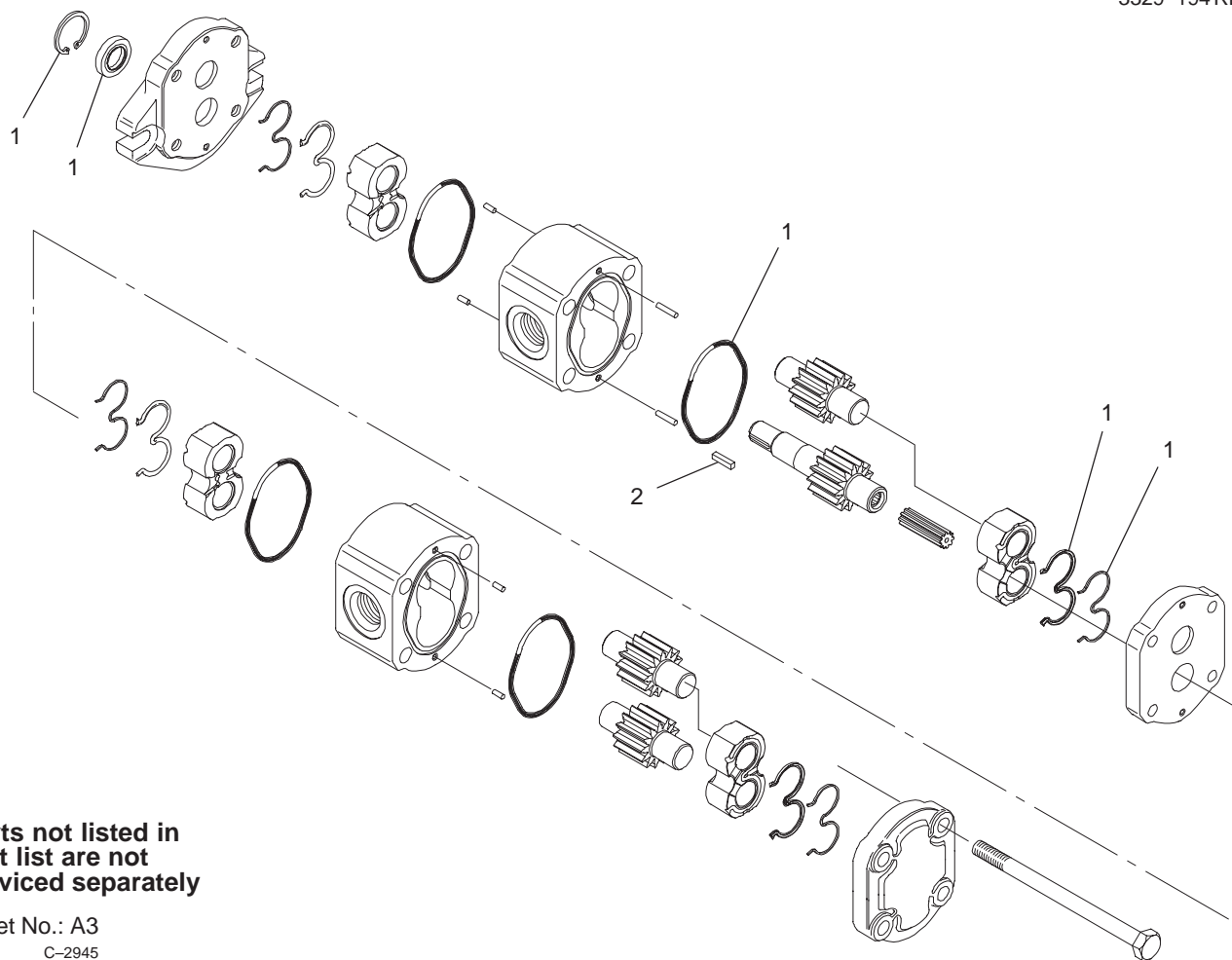

Parts not listed in
part list are not
serviced separately

Sheet No.: A3
C-2945

Hydraulic Gear Pump Assembly No. 98-2752

Ref. No.	Part No.	Qty.	Description
1	100-4237	1	Kit-Seal, Pump
2	100-4238	1	Key-Square

Ref. No.	Part No.	Qty.	Description

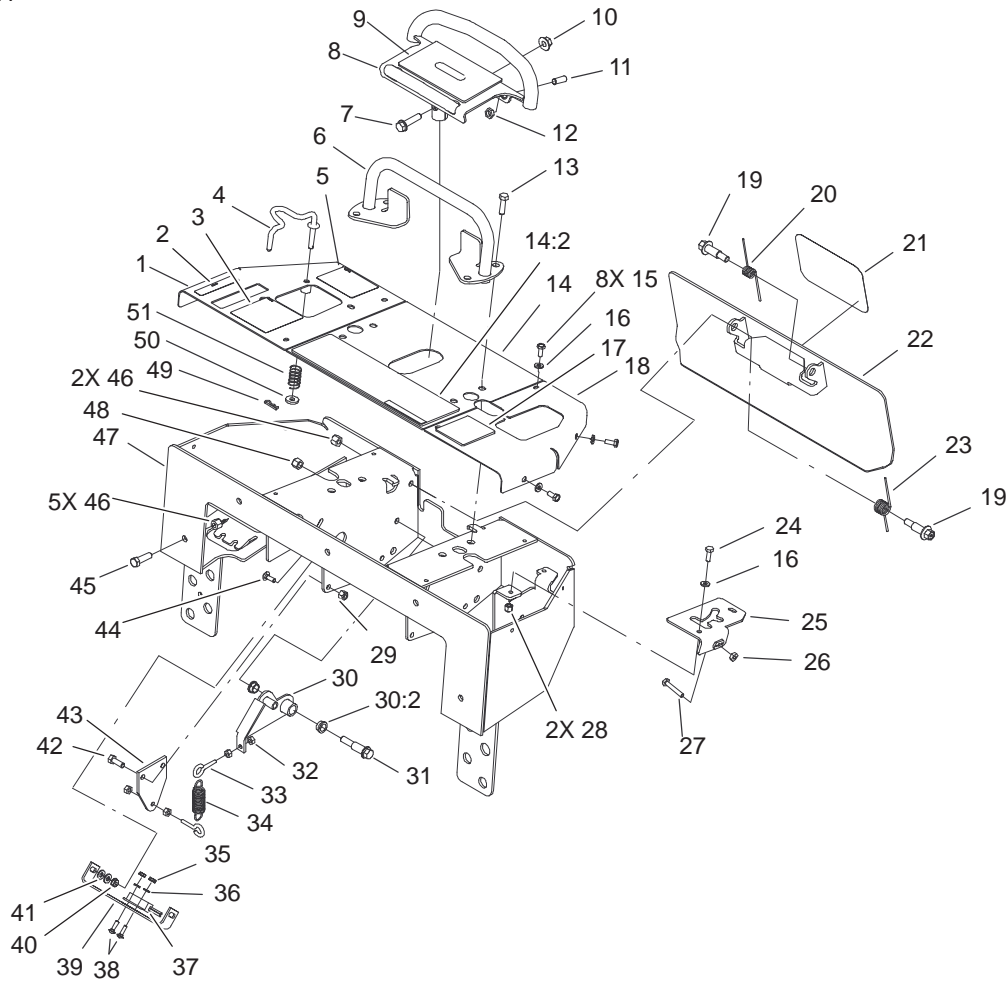

Sheet No.: 11

Control Panel Assembly

Ref. No.	Part No.	Qty.	Description
1	105-5824-01	1	RH Panel ASM
2	104-2838	1	Decal-Brake
3	104-2837	1	Decal-Loader
4	104-2833	1	Rod-Interlock
5	104-2844	1	Decal-Interlock
6	98-8400-03	1	Reference Bar ASM
7	3234-18	1	Screw-HHF
8	104-9970-03	1	Control Handle ASM
9	100-6138	1	Decal-Traction
10	32128-43	1	Nut-Flange
11	3247-6	2	Screw-Set
12	3218-3	2	Nut-Jam
13	322-16	4	Screw-HH
14	100-6144	1	Center Panel ASM
14:2	100-6140	1	Decal-Danger
15	32144-44	8	Screw-HWH
16	3256-16	2	Washer-Flat
17	100-6136	1	Decal-Auxiliary
18	98-8428-01	1	Panel-LH
19	62-1330	2	Bolt-Shoulder
20	98-8424	1	Spring-Torsion, RH
21	105-1217	1	Decal-Toro
22	98-8417-03	1	Reverse Plate ASM
23	98-8425	1	Spring-Torsion, LH
24	321-4	2	Screw-HH
25	100-6126-01	1	Auxiliary Stop ASM

Ref. No.	Part No.	Qty.	Description
26	3218-1	1	Nut-Jam
27	321-9	1	Screw-HH
28	3296-8	2	Nut-Lock, NI
29	3296-29	2	Nut-Lock, NI
30	100-4203	1	Neutral Centering Lever ASM
30:2	256-156	2	Bushing-Flange
31	66-0560	1	Bolt-Shoulder
32	3217-5	4	Nut-Hex
33	71-2870	2	Bolt-Eye
34	105-1210	1	Spring-Extension
35	32149-7	2	Nut-Keps
36	3256-51	2	Washer-Flat
37	100-1270	1	Switch-Proximity
38	3229-20	2	Screw-CARR
39	100-1263	1	Plate-Switch
40	32149-2	2	Nut
41	3256-22	4	Washer-Flat
42	322-4	2	Screw-HH
43	100-1261-03	1	Bracket-Spring
44	3229-1	2	Screw-CARR
45	323-7	5	Screw-HH
46	3296-39	7	Nut-Lock, NI
47	95-3540-01	1	Control Panel ASM
48	3296-6	1	Nut-Lock, NI
49	3290-307	1	Pin-Hair

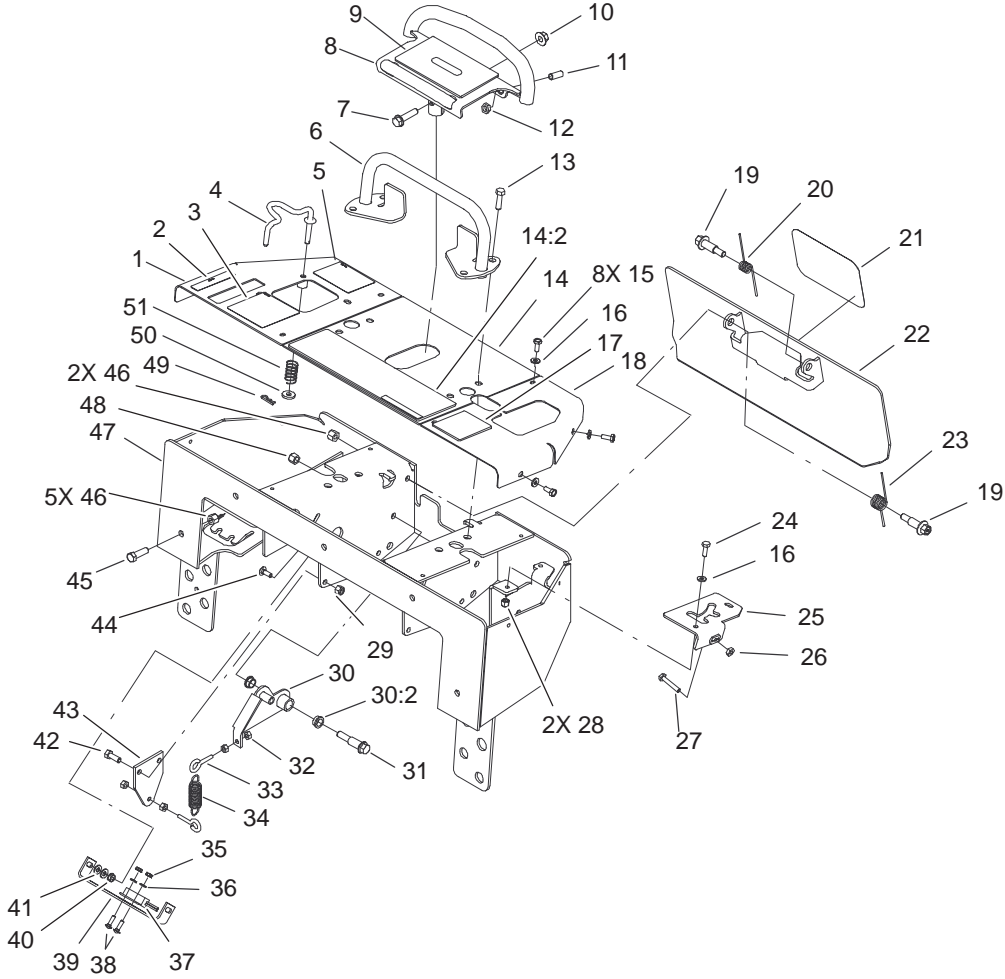

Control Panel Assembly (Continued)

Ref. No.	Part No.	Qty.	Description
50	88-7200	1	Washer-Flat
51	85-6750	1	Spring-Control

Ref. No.	Part No.	Qty.	Description

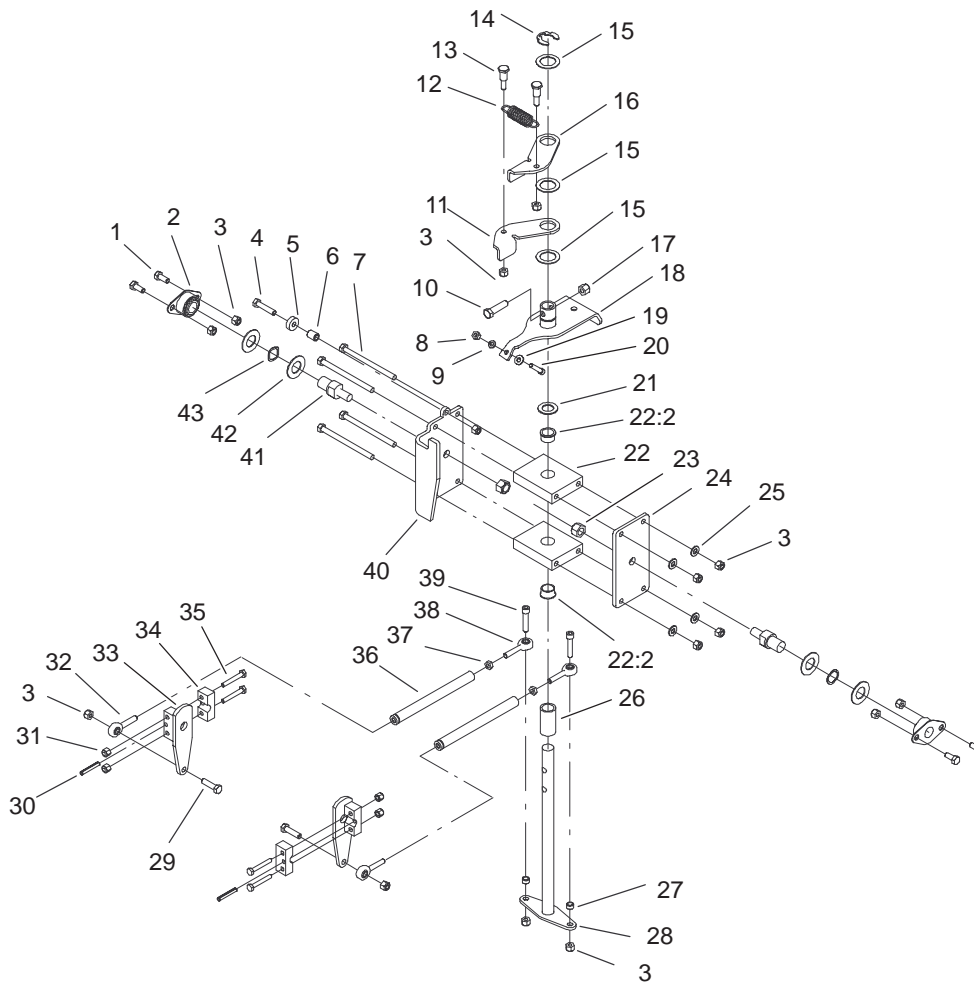

Sheet No.: 12

Traction Control Assembly

Ref. No.	Part No.	Qty.	Description
1	322-3	4	Screw-HH
2	68-2970	2	Bushing
3	3296-29	15	Nut-Lock, NI
4	322-7	1	Screw-HH
5	251-259	1	Bearing
6	88-7450	1	Spacer-Lever, Control
7	322-38	4	Screw-HH
8	3217-5	1	Nut-Hex
9	3253-3	1	Washer-Lock
10	323-8	1	Screw-HH
11	98-8407	1	Lever-Return, RH
12	105-1210	1	Spring-Extension
13	63-2650	2	Screw-Shoulder
14	32151-91	1	Ring-Retaining
15	3256-42	3	Washer-Flat
16	98-8408	1	Lever-Return, LH
17	3296-39	1	Nut-Lock, NI
18	104-9968	1	Pivot Lever ASM
19	3256-22	1	Washer-Flat
20	3274-51	1	Screw-HSH
21	257-8	1	Washer-Thrust
22	104-9972	2	Bearing Support Block ASM
22:2	256-252	1	Bearing-Flange
23	3296-23	2	Nut-Lock, NI
24	104-9975-03	1	Bracket-Pivot, LH

Ref. No.	Part No.	Qty.	Description
25	3256-23	4	Washer-Flat
26	104-9974	1	Spacer-Pivot, Rod
27	92-3133	2	Spacer-Lever, Traction
28	98-8411	1	Drive Rod ASM
29	322-6	2	Screw-HH
30	100-6148	2	Pin-Spring
31	3296-8	4	Nut-Lock, NI
32	2411-53	2	Bearing-Rod End, LH
33	98-8433	2	Pump Lever ASM
34	98-8434	2	Clamp-Traction
35	321-10	4	Screw-HH
36	95-3711	2	Rod-Linkage
37	3220-2	2	Nut
38	2411-52	2	Bearing-Rod End, RH
39	3274-83	2	Screw-HSH
40	104-9976-03	1	Bracket-Pivot, RH
41	95-3684	2	Shaft-Arm, Pivot
42	3256-39	6	Washer-Flat
43	95-3703	2	Washer-Spring, Wave

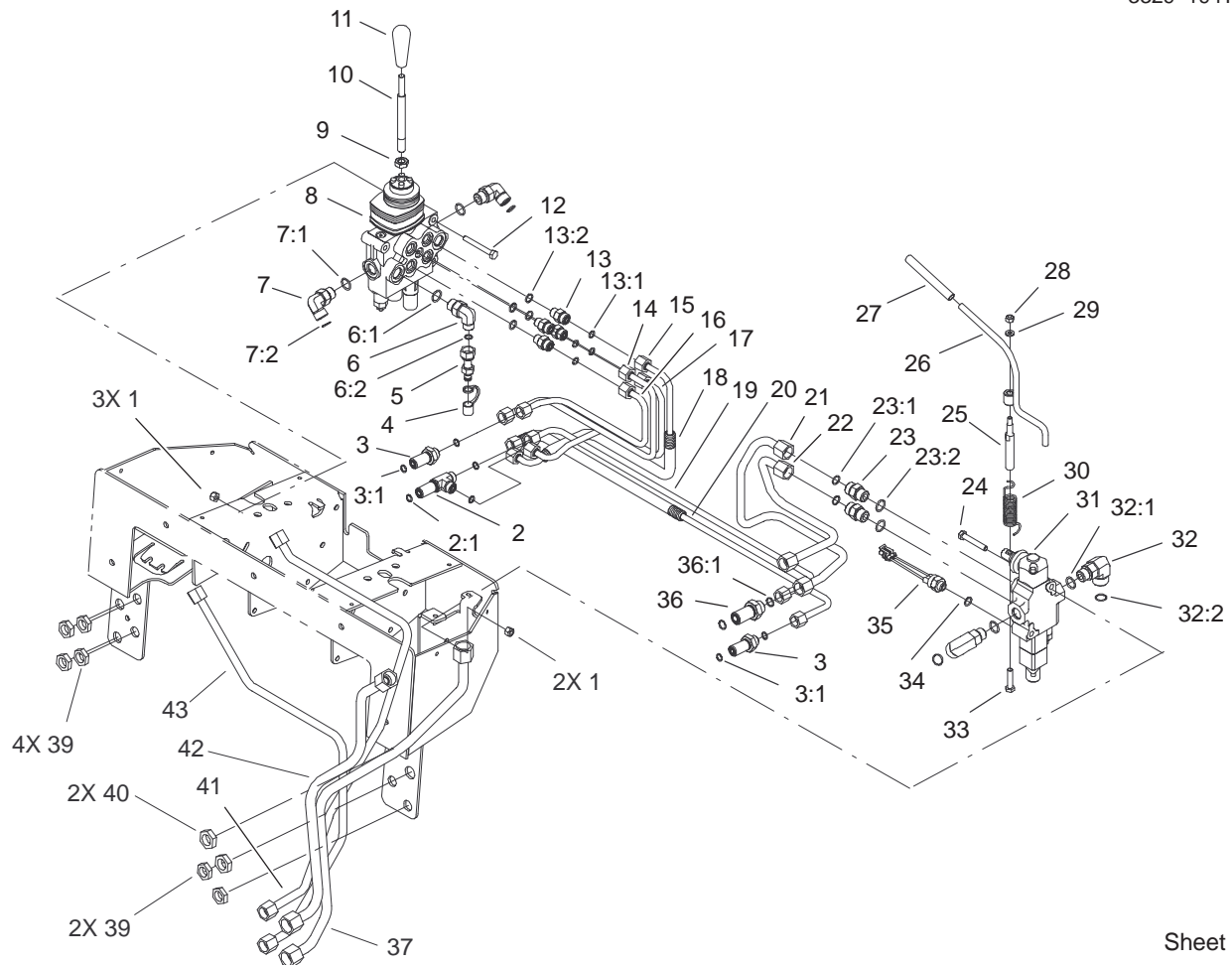

Sheet No.: 13

Principal Hydraulic Assembly

Ref. No.	Part No.	Qty.	Description
1	3296-29	5	Nut-Lock, NI
2	340-68	2	Fitting-Tee, Bulkhead
2:1	237-22	3	O-Ring
3	340-71	4	Fitting-Straight, Bulkhead
3:1	237-22	2	O-Ring
4	354-79	1	Cap-Dust
5	86-5480	1	Nipple-Test
6	340-18	1	Fitting-HYD, 90°
6:1	237-79	1	O-Ring
6:2	237-22	1	O-Ring
7	340-98	2	Fitting-HYD, 90°
7:1	237-79	1	O-Ring
7:2	237-30	1	O-Ring
8	95-3536	1	Valve-2 Spool
9	51-2070	1	Nut
10	95-3569	1	Shaft-Handle, Lift/Tilt
11	98-0152	1	Knob-Tapered
12	322-12	3	Screw-HH
13	340-2	4	Fitting-Straight, HYD
13:1	237-22	1	O-Ring
13:2	237-42	1	O-Ring
14	98-2788	1	HYD Tube ASM
15	98-2784	1	HYD Tube ASM
16	98-2789	1	HYD Tube ASM
17	98-2785	1	HYD Tube ASM

Ref. No.	Part No.	Qty.	Description
18	100-1287	2	Conduit-Convolutd
19	98-2787	1	HYD Tube ASM
20	98-2786	1	HYD Tube ASM
21	98-2790	1	HYD Tube ASM
22	98-2791	1	HYD Tube ASM
23	340-4	2	Adapter
23:1	237-30	1	O-Ring
23:2	237-79	1	O-Ring
24	322-11	2	Screw-HH
25	104-2827	1	Spacer-Hiflo
26	100-4246	1	Auxiliary Lever ASM
27	92-6798	1	Cap-Rod, Tilt
28	3296-42	1	Nut-Lock, NI
29	3256-16	1	Washer-Flat
30	100-6129	1	Spring-Torsion
31	104-2831	1	Valve-1 Spool
32	340-153	2	Fitting-HYD
32:1	237-79	1	O-Ring
32:2	237-151	1	O-Ring
33	48-7740	1	Screw
34	237-42	1	O-Ring
35	72-4310	1	Switch-Ball
36	340-161	2	Fitting-Bulkhead
36:1	237-30	2	O-Ring
37	104-5708	1	HYD Tube ASM
39	340-70	6	Nut-Lock

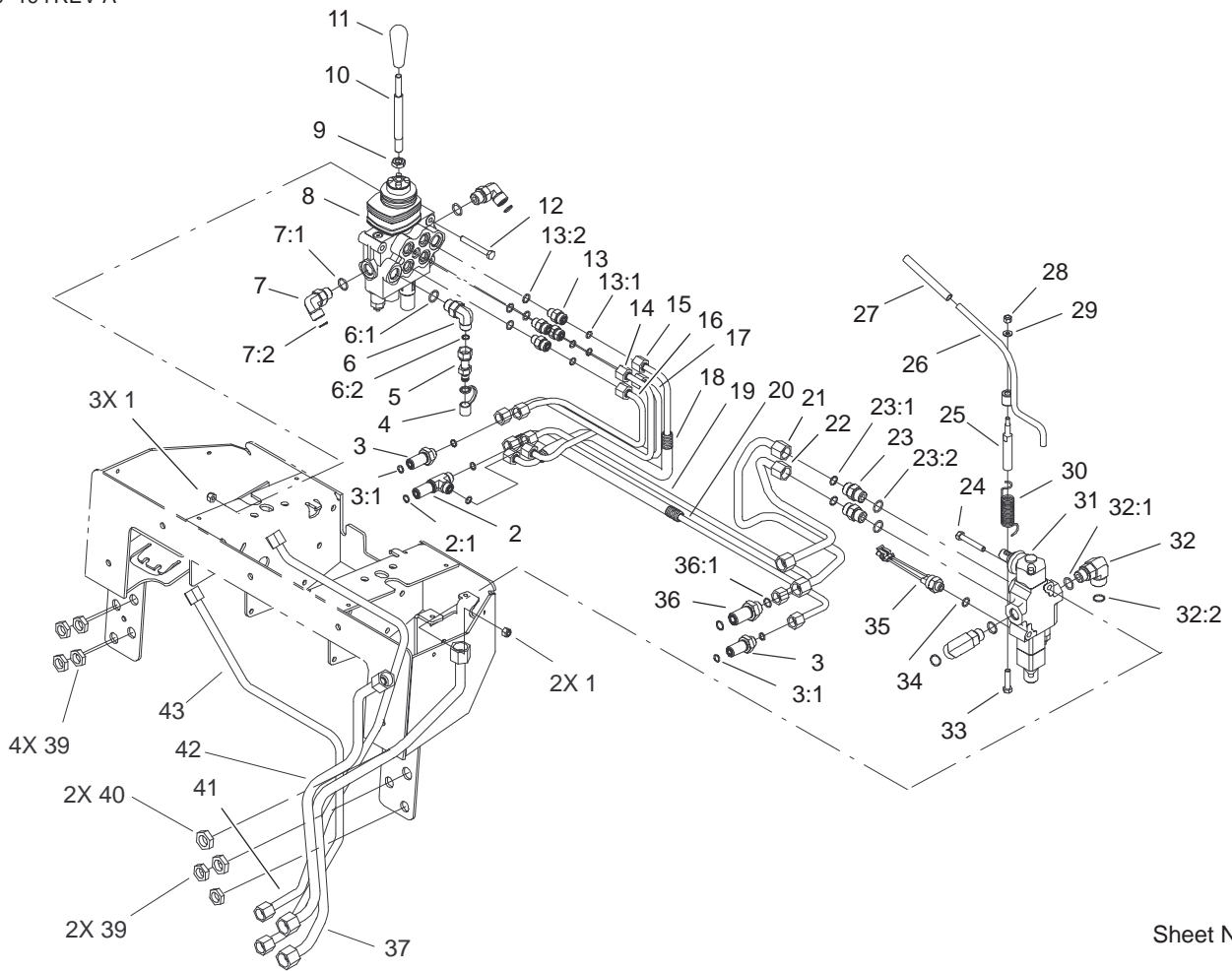

Sheet No.: 13

Principal Hydraulic Assembly (Continued)

Ref. No.	Part No.	Qty.	Description
40	340-127	2	Nut-Bulkhead
41	104-5709	1	HYD Tube ASM
42	104-5707	1	HYD Tube ASM
43	104-5710	1	HYD Tube ASM

Ref. No.	Part No.	Qty.	Description

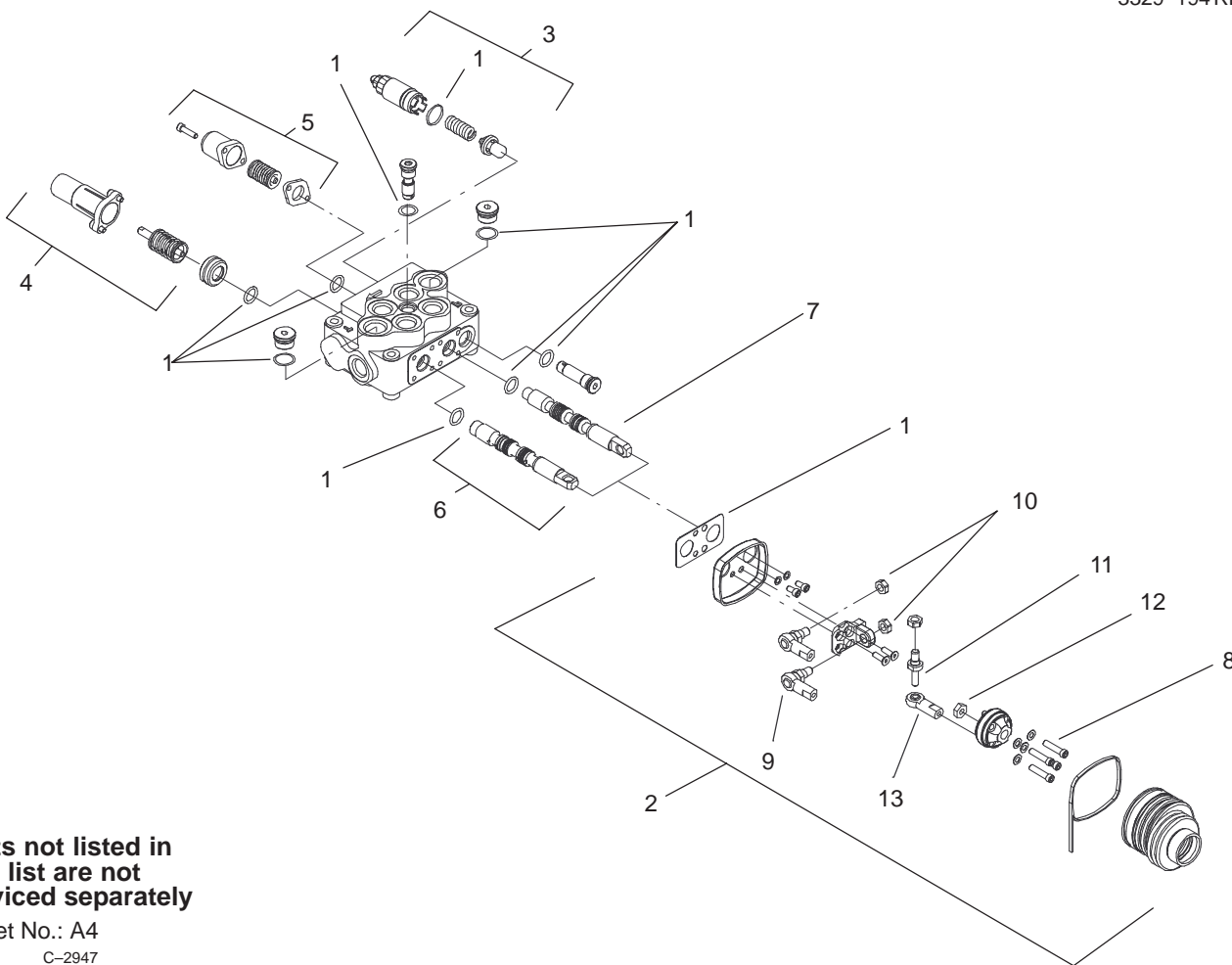

Parts not listed in part list are not serviced separately

Sheet No.: A4

C-2947

Two Spool Valve Assembly No. 95-3536

Ref. No.	Part No.	Qty.	Description
1	100-4249	1	Seal Kit
2	100-7230	1	Kit-Joystick ASM
3	100-8805	1	Valve-Relief
4	106-7569	1	Kit-Spring, Valve
5	106-7570	1	Kit-Spring
6	106-7571	1	Spool
7	106-7572	1	Spool
8	106-7573	4	Screw-Joystick
9	106-7574	2	Joint-Articulated
10	106-7575	3	Nut-Joystick
11	106-7576	1	Pin-Joystick
12	106-7577	1	Nut-Galvanized
13	106-7578	1	End-Rod

Ref. No.	Part No.	Qty.	Description

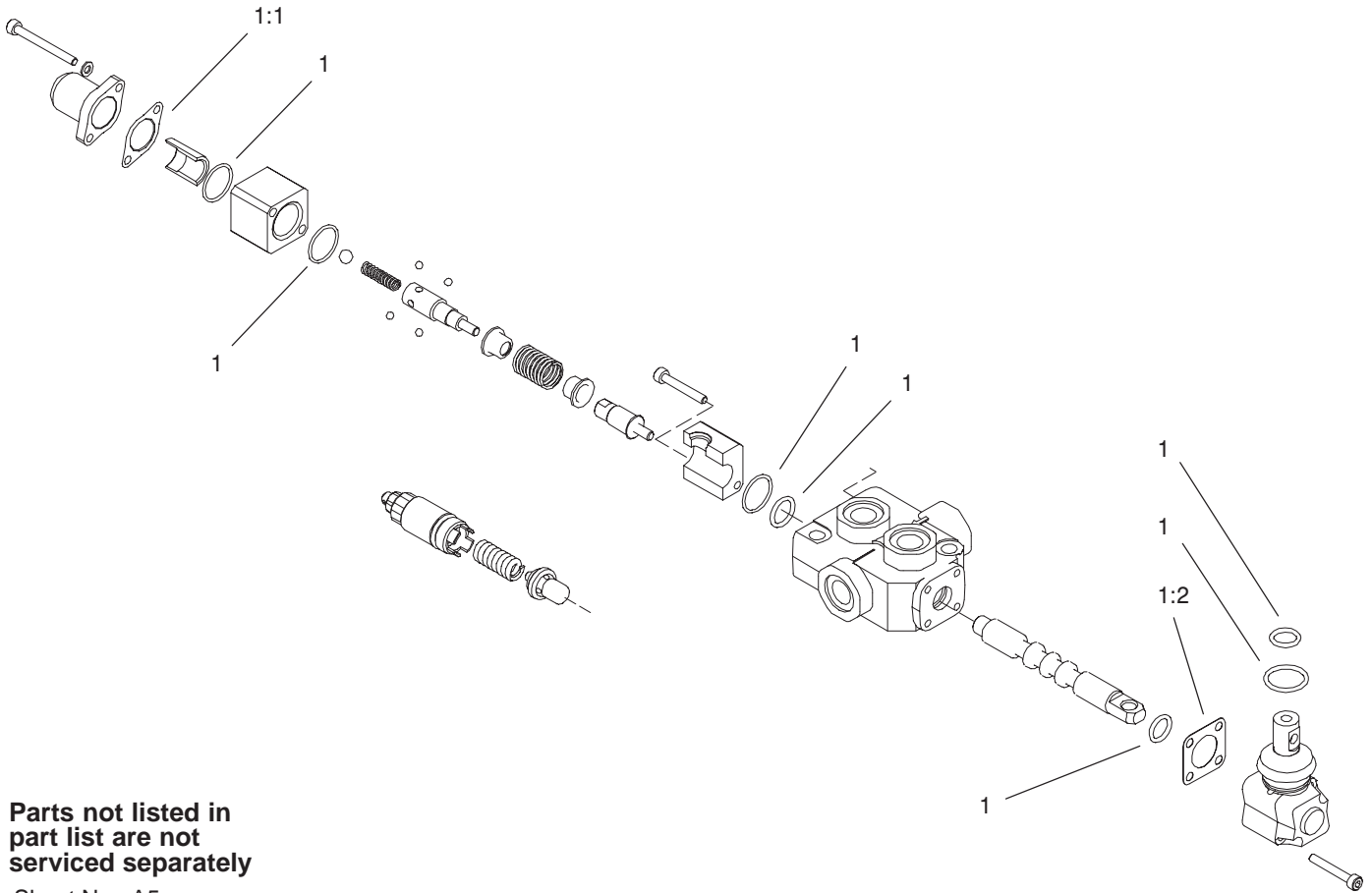

Parts not listed in part list are not serviced separately

Sheet No.: A5
C-2946

One Spool Valve Assembly No. 104-2831

Ref. No.	Part No.	Qty.	Description
1	99-4391	1	Seal Kit
1:1	99-3074	1	Gasket
1:2	99-3075	3	Gasket

Ref. No.	Part No.	Qty.	Description
----------	----------	------	-------------

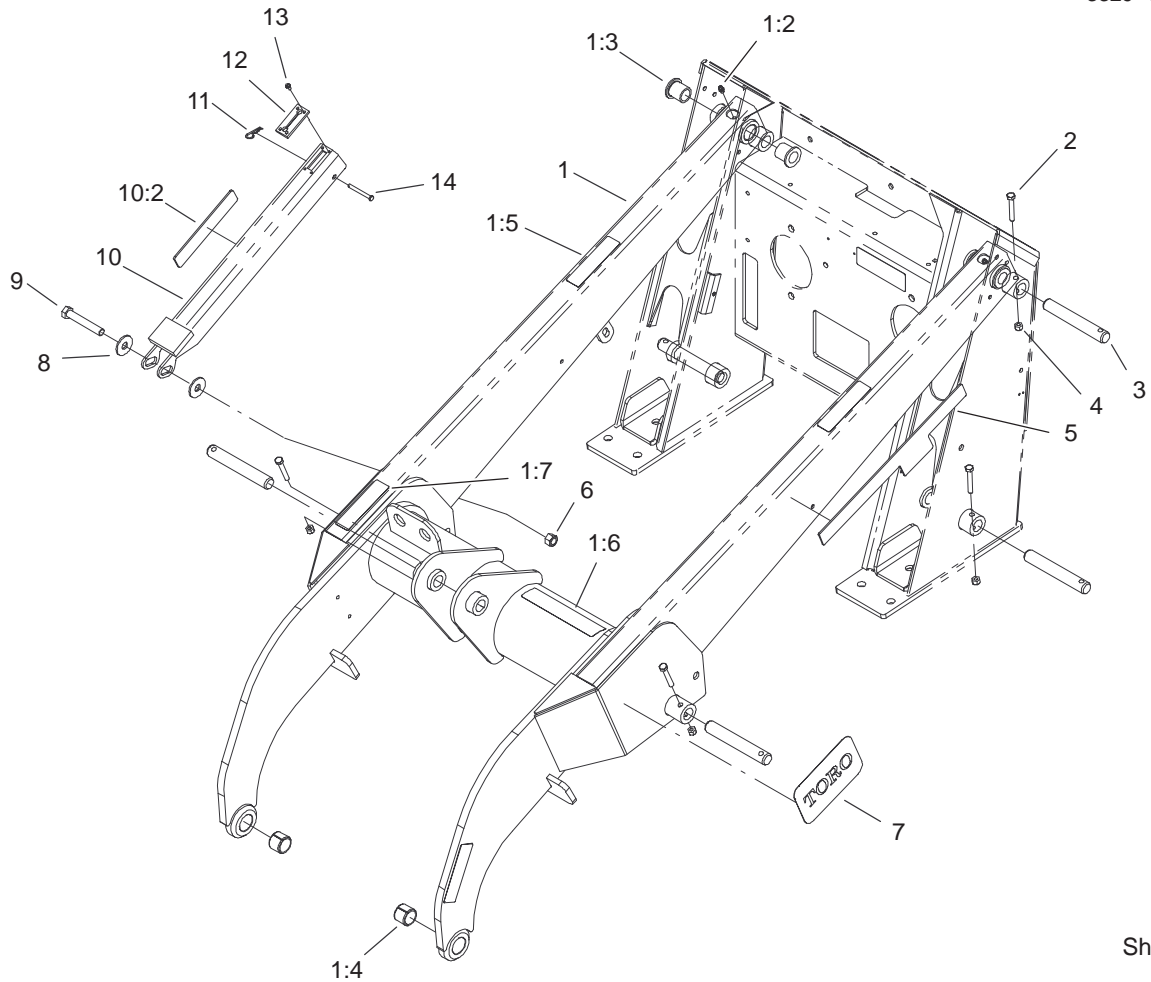

Sheet No.: 14

Loader Arm Assembly

Ref. No.	Part No.	Qty.	Description
1	100-6145	1	Loader Arm ASM
1:2	302-5	2	Fitting-Grease
1:3	95-3577	4	Bushing
1:4	98-4871	2	Bushing-Tension
1:5	100-6141	4	Decal-Pinch
1:6	100-6132	1	Decal-Caution
1:7	100-6101	1	Decal-Caution
2	322-10	7	Screw-HH
3	104-2849	7	Pin-Locking
4	3296-29	7	Nut-Lock, NI
5	105-8430	2	Decal
6	3296-23	1	Nut-Lock, NI
7	105-1217	2	Decal-Toro
8	68-1440	2	Washer-Rubber
9	325-13	1	Screw-HH
10	100-6105	1	Locking Arm ASM
10:2	100-6135	1	Decal-Danger
11	3290-250	1	Pin-Hair
12	98-0083	1	Stop-Rubber
13	32144-107	4	Screw
14	283-48	1	Pin-Clevis

Ref. No.	Part No.	Qty.	Description
----------	----------	------	-------------

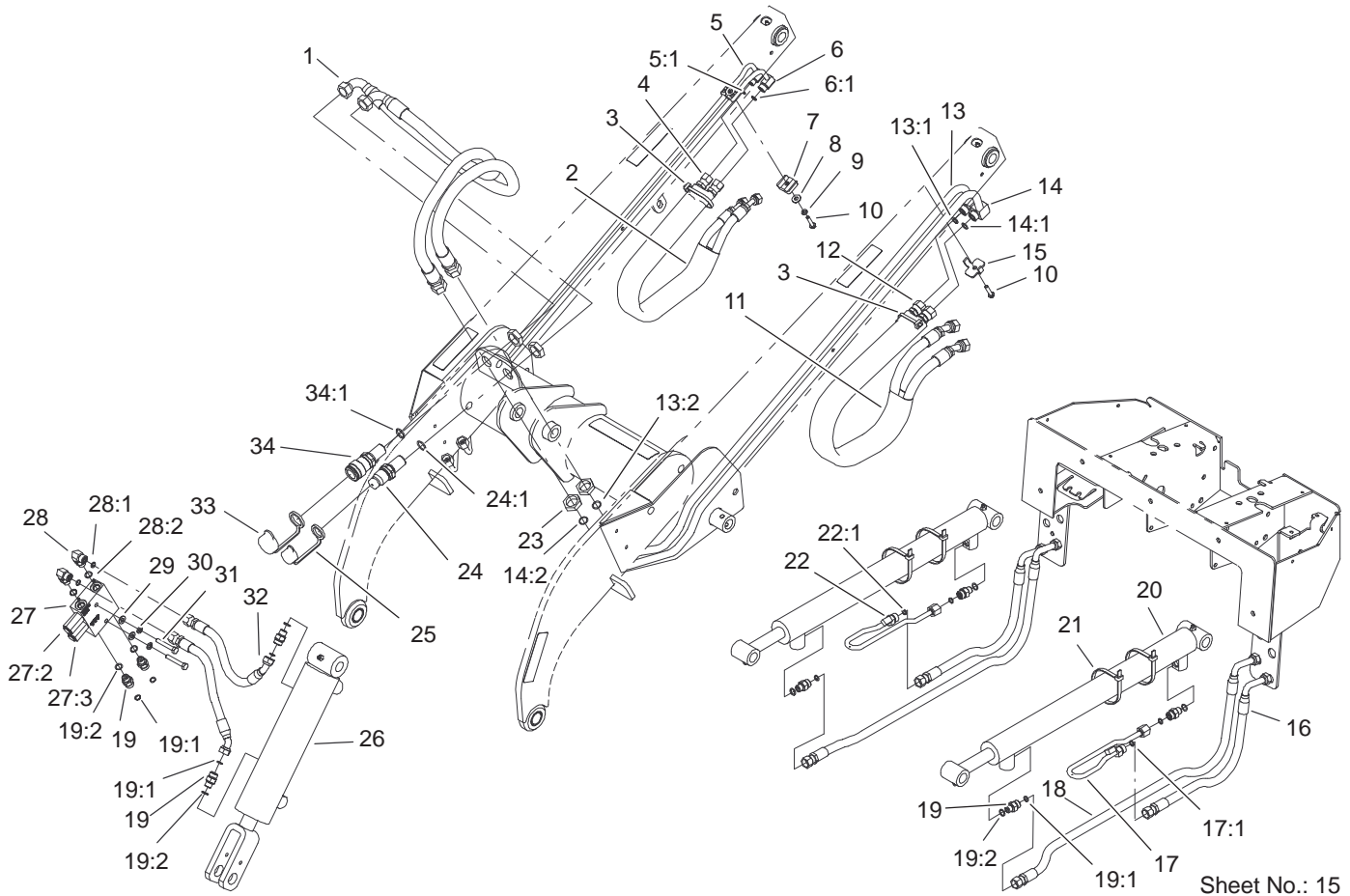

Sheet No.: 15

Loader Arm Hydraulic Assembly

Ref. No.	Part No.	Qty.	Description
1	99-6193	2	Hose ASM
2	100-6127	1	Sleeve-Protective
3	3290-378	2	Tie-Cable
4	98-0213	2	HYD Hose ASM
5	104-9965	1	HYD Tube ASM
5:1	237-22	1	O-Ring
6	104-9964	1	HYD Tube ASM
6:1	237-22	1	O-Ring
7	56-7973	2	Clamp-Tube
8	3256-2	1	Washer-Flat
9	3253-3	1	Washer-Lock
10	32144-110	2	Screw-HWH
11	100-6128	1	Sleeve-Protective
12	98-0242	2	HYD Hose ASM
13	104-9962	1	HYD Tube ASM
13:1	237-30	1	O-Ring
13:2	237-65	1	O-Ring
14	104-9963	1	HYD Tube ASM
14:1	237-30	1	O-Ring
14:2	237-65	1	O-Ring
15	98-0237	1	Plate-Clamp, Tube
16	98-0216	2	HYD Hose ASM
17	100-1259	1	HYD Tube ASM
17:1	237-22	1	O-Ring
18	98-0217	2	HYD Hose ASM
19	340-2	8	Fitting-Straight, HYD

Ref. No.	Part No.	Qty.	Description
19:1	237-22	1	O-Ring
19:2	237-42	1	O-Ring
20	99-6162	2	Cylinder-Lift
21	3334-945	4	Tie-Cable
22	100-1258	1	HYD Tube ASM
22:1	237-22	1	O-Ring
23	340-74	4	Locknut-Bulkhead
24	105-8395	1	Bulkhead Nipple ASM
24:1	237-65	1	O-Ring
*24:2	100-6120	1	Seal Kit
25	100-8815	1	Cap-Dust, Nipple
26	105-8370	1	Cylinder-Tilt
27	100-4205	1	Valve-Relief, Crossover
*27:1	100-4219	2	Seal Kit
27:2	100-4220	1	Cartridge-Relief
27:3	100-4221	1	Cartridge-Relief
28	340-77	2	Fitting-HYD, 90°
28:1	237-22	1	O-Ring
28:2	237-42	1	O-Ring
29	3256-23	2	Washer-Flat
30	3253-4	2	Washer-Lock
31	322-10	2	Screw-HH
32	98-0207	2	HYD Hose ASM
33	100-8816	1	Cap-Dust, Coupler

* Not illustrated

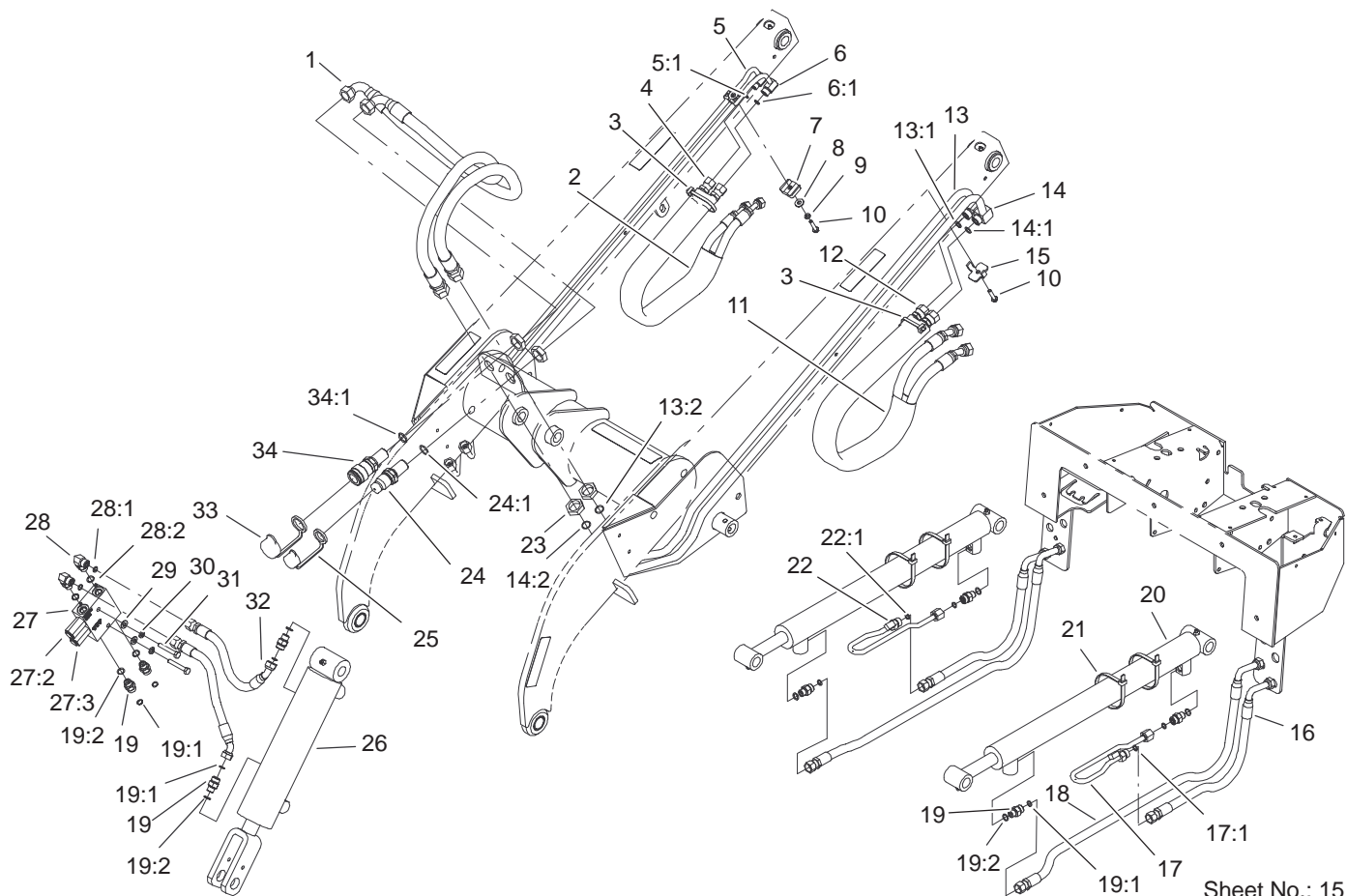

Loader Arm Hydraulic Assembly (Continued)

Ref. No.	Part No.	Qty.	Description
34	105-8394	1	Bulkhead Coupler ASM
34:1	237-65	1	O-Ring
*34:2	105-8396	1	Seal Kit

Ref. No.	Part No.	Qty.	Description

* Not illustrated

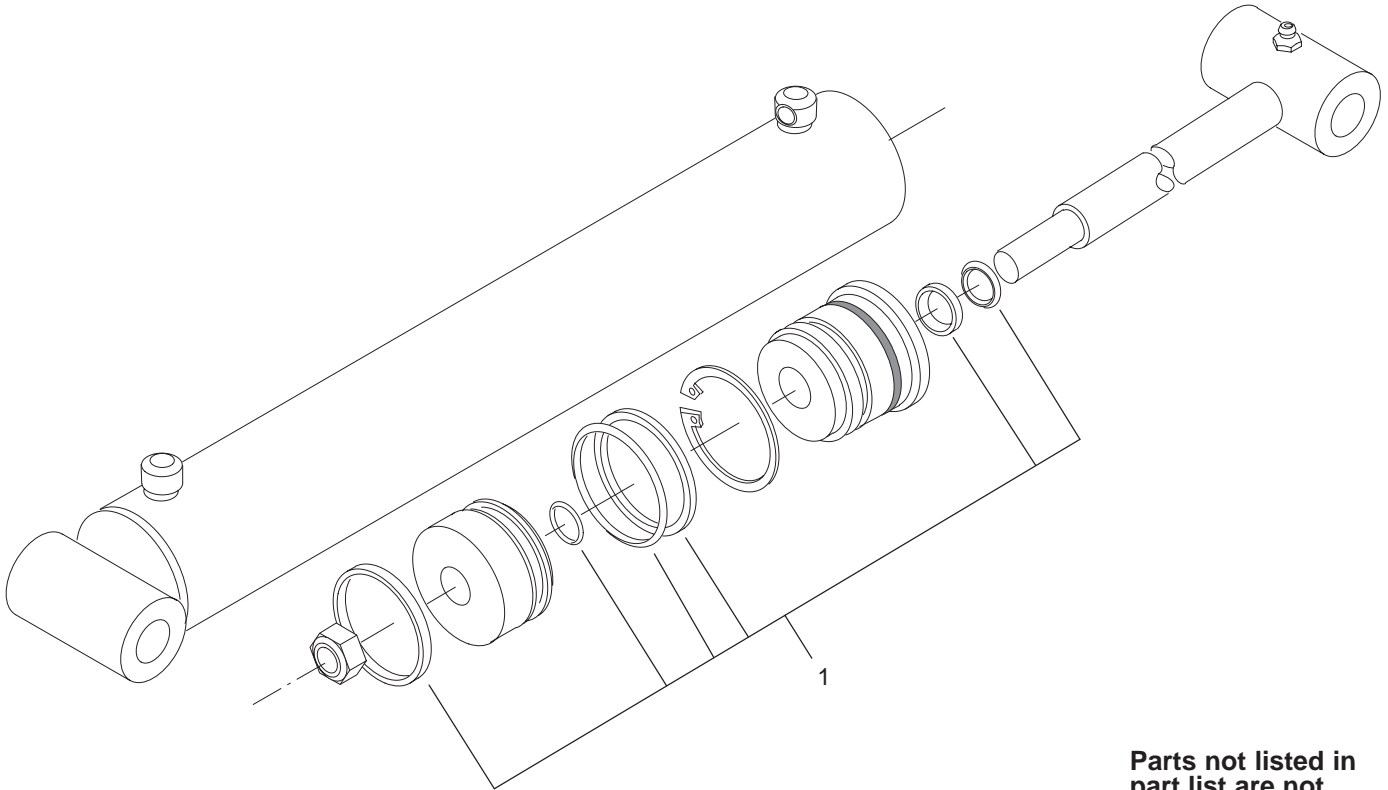

**Parts not listed in
part list are not
serviced separately**

Sheet No.: A6
C-3619

Hydraulic Cylinder Assembly No. 99-6162

Ref. No.	Part No.	Qty.	Description
1	100-6107	1	Seal Kit

Ref. No.	Part No.	Qty.	Description
----------	----------	------	-------------

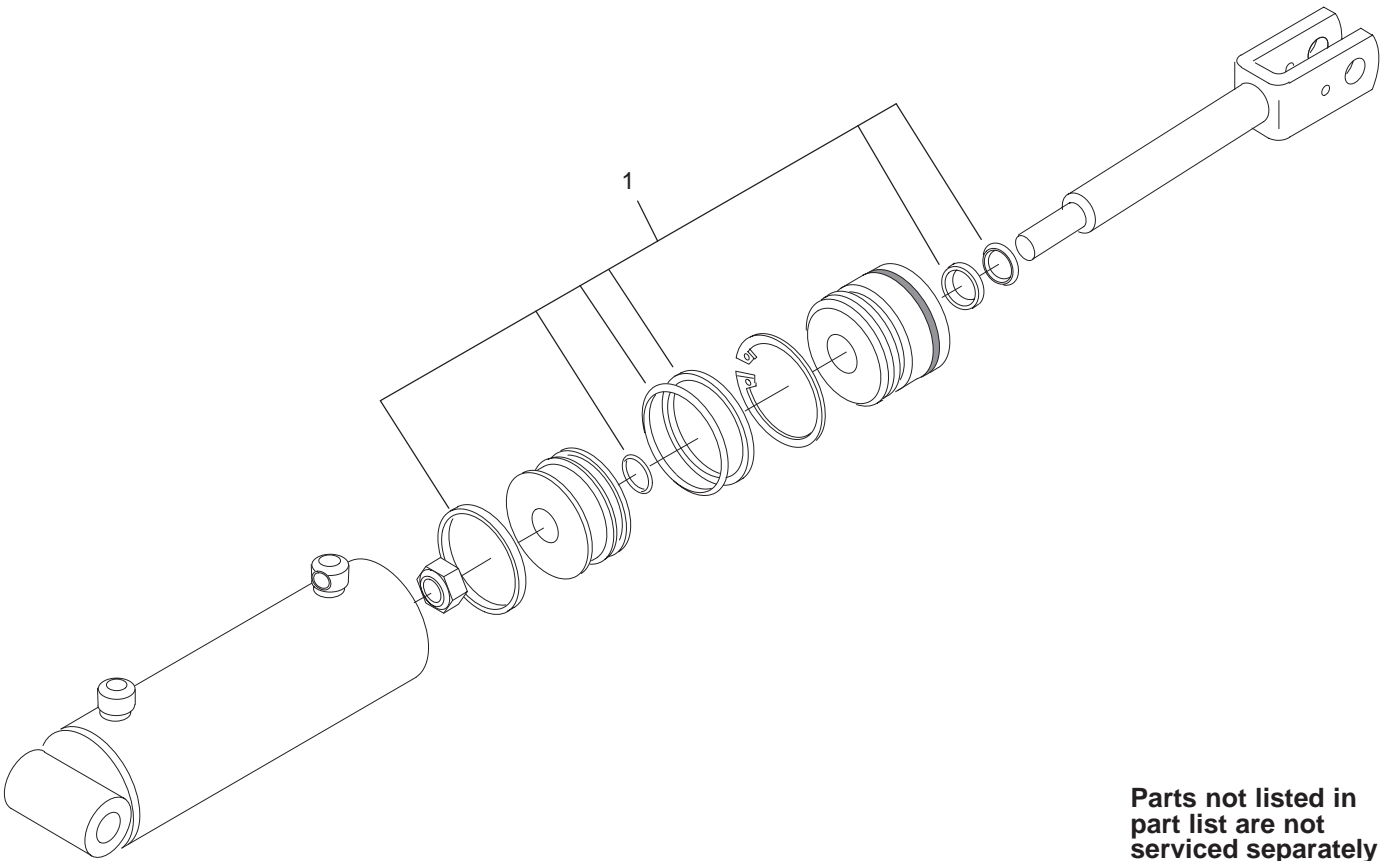

**Parts not listed in
part list are not
serviced separately**

Sheet No.: A7
C-3618

Hydraulic Cylinder Assembly No. 95-3578

Ref. No.	Part No.	Qty.	Description
1	106-7567	1	Kit-Seal

Ref. No.	Part No.	Qty.	Description
----------	----------	------	-------------

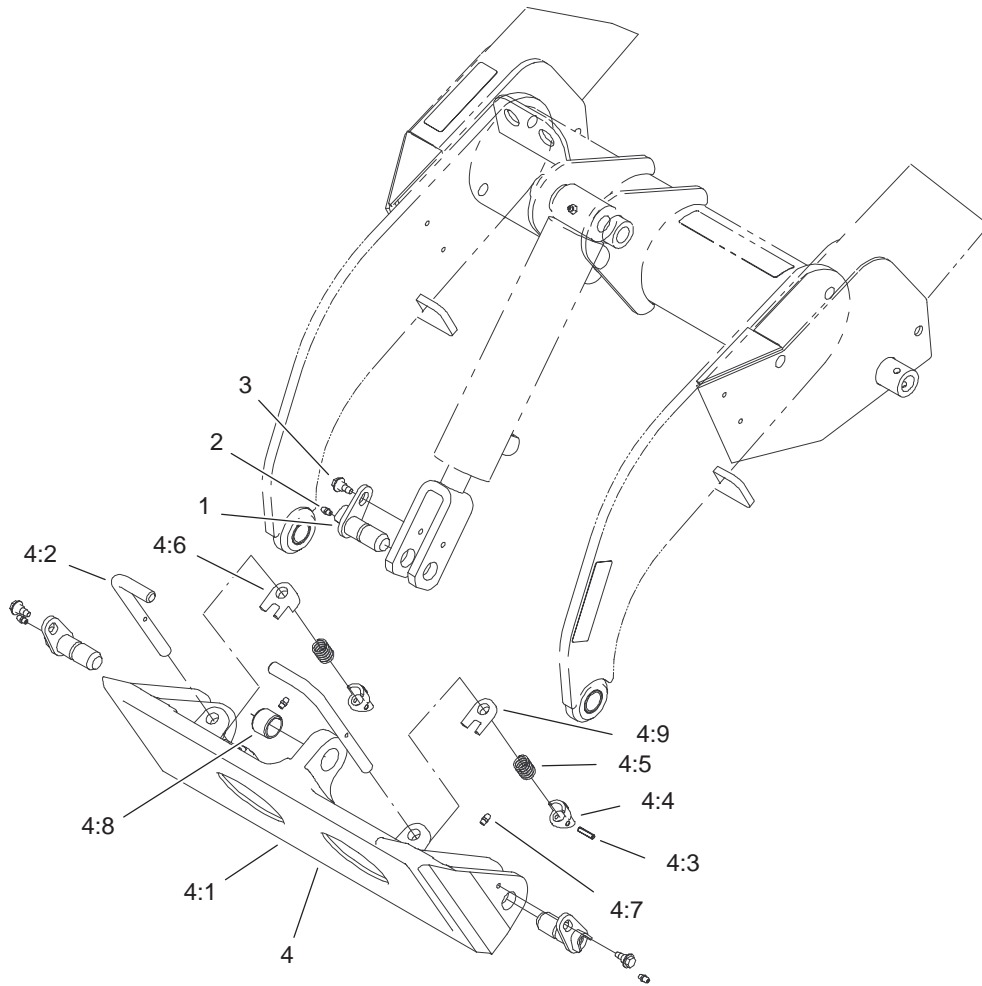

Sheet No.: 16

Quick Attach Assembly

Ref. No.	Part No.	Qty.	Description
1	99-1414	3	Pin-Pivot
2	302-5	3	Fitting-Grease
3	99-5105	3	Bolt-Shoulder
4	105-8364	1	Quick Attach ASM
4:1	105-0245-03	1	Mount-Attach, Quick
4:2	105-8367	2	Pin-Locking
4:3	3285-1	2	Pin-Grooved
4:4	105-0246	2	Cam
4:5	98-4694	2	Spring-Compression
4:6	104-5909	1	Stop-RH
4:7	302-5	2	Fitting-Grease
4:8	98-4871	1	Bushing-Tension
4:9	104-5903	1	Stop-LH

Ref. No.	Part No.	Qty.	Description

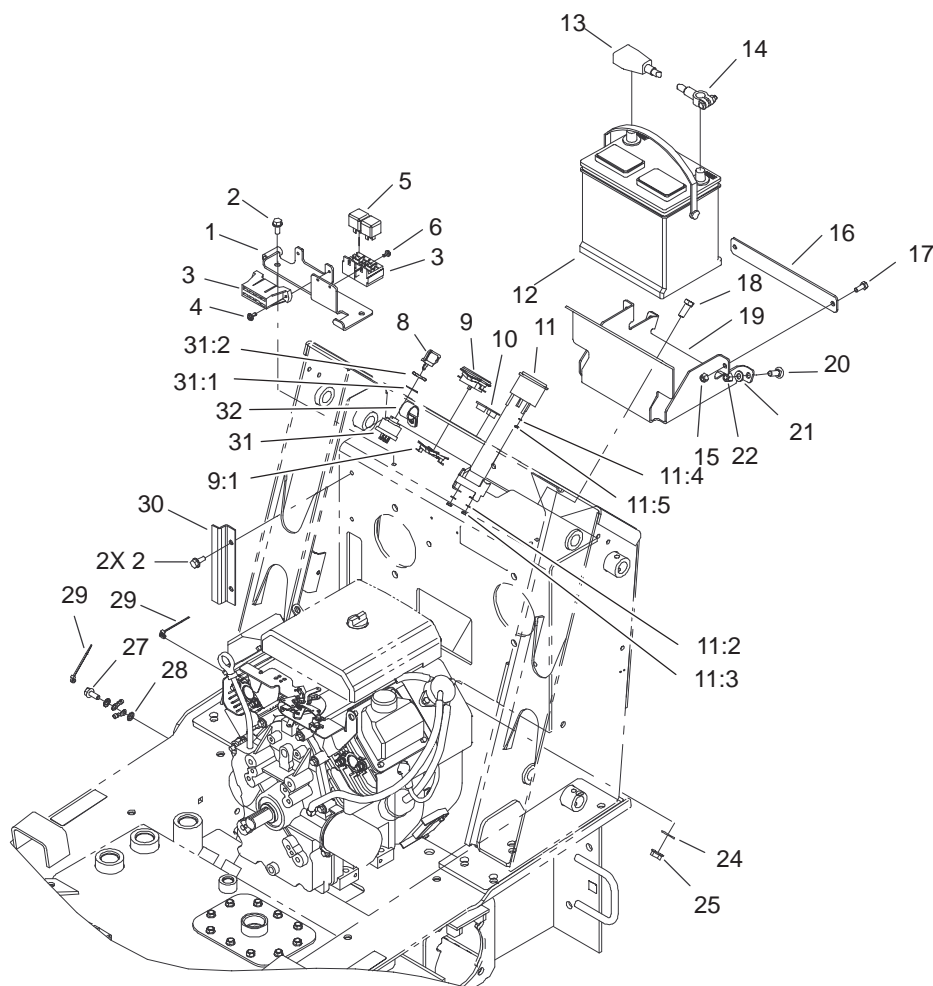

Sheet No.: 17

Electrical Assembly

Ref. No.	Part No.	Qty.	Description
1	106-2558-03	1	Fuse/Relay Bracket ASM
2	32144-70	4	Screw-HH
3	106-4152	1	Harness-Wire
*3:1	114594	1	Fuse-10 Amp
*3:2	109102	1	Fuse-25 Amp
*3:3	NN10277	1	Fuse-30 Amp
*3:4	109355	1	Fuse-15 Amp
4	12-5450	2	Screw
5	98-7249	2	Relay
6	104-2065	2	Screw-HWH
8	63-8360	1	Key-Ignition
9	104-7427	1	Hourmeter-Inductive
9:1	104-4234	1	Clip-Mounting
10	99-7420	1	Plug-Hole
11	66-2940	1	Gauge-Fuel
11:2	3254-1	2	Washer-Lock, Int
11:3	3217-27	2	Nut-Hex
11:4	3255-24	3	Washer-Lock/Ext
11:5	3217-16	3	Nut-Hex
12	104-9979	1	Battery (Dry)
13	99-6185	1	Cable-Battery, Positive
14	99-6186	1	Cable-Battery, Negative
15	3296-29	2	Nut-Lock, NI

Ref. No.	Part No.	Qty.	Description
16	105-0371-01	1	Clamp-Battery
17	322-3	2	Screw-HH
18	324-4	2	Screw-HH
19	105-0370-01	1	Tray-Mounting, Battery
20	3231-22	2	Screw-CARR
21	3256-38	2	Washer-Flat
22	3296-39	2	Nut-Lock, NI
24	3256-4	2	Washer-Flat
25	32128-42	2	Nut-HF
27	33104-020	1	Screw-HHF
28	3255-8	2	Washer-Lock
29	3290-381	2	Tie-Cable
30	100-6117-01	1	Shield-Wiring
31	88-9830	1	Key Switch ASM
31:1	3254-5	1	Washer-Tooth
31:2	218-461	1	Nut-HH
32	2412-41	1	Clamp

* Not illustrated

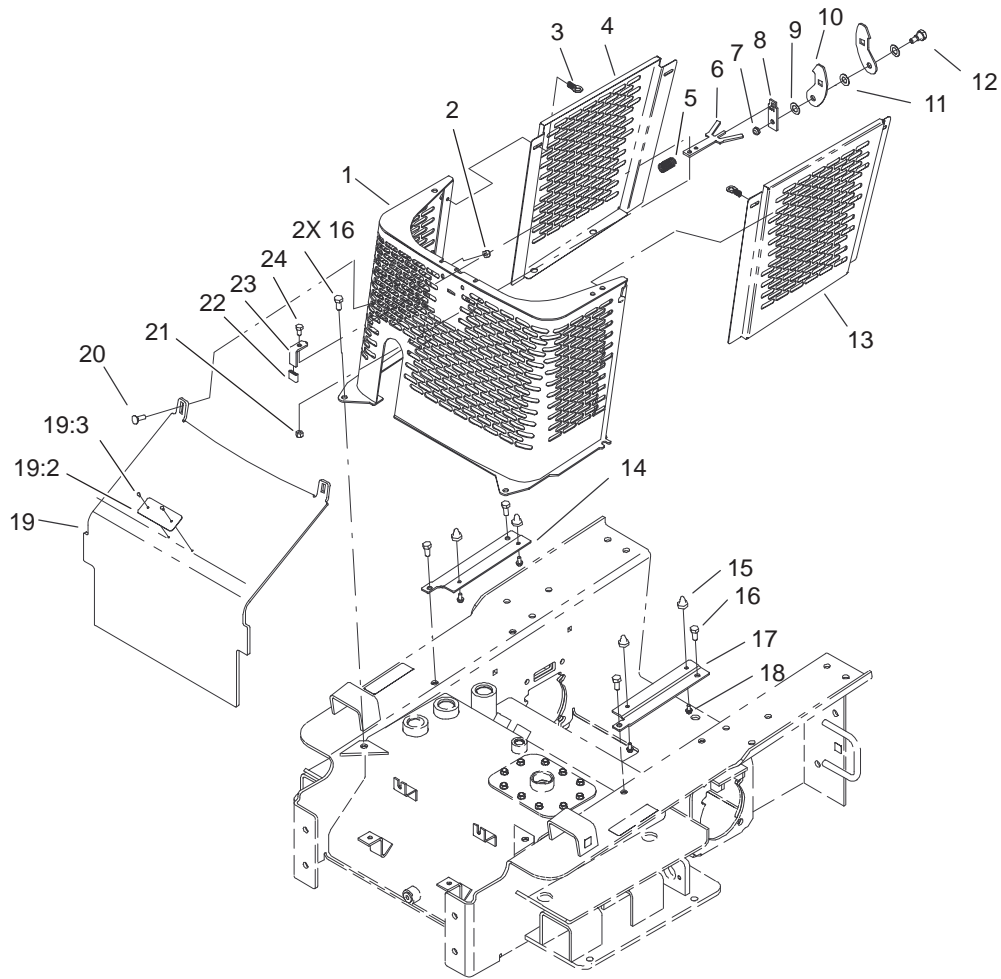

Sheet No.: 18

Grill Assembly

Ref. No.	Part No.	Qty.	Description
1	100-1282-03	1	Grill ASM
2	3296-29	2	Nut-Lock, NI
3	95-4013	2	Latch ASM
4	105-0380-03	1	Panel-Side, RH
5	100-6102	1	Spring-Compression
6	100-4226	1	Lever-Latch
7	3296-59	1	Nut-Lock, NI
8	100-4225	1	Spacer-Latch
9	47-2910	1	Washer-Thrust
10	100-4224	2	Latch-Hood
11	257-10	2	Washer-Thrust
12	27-5240	1	Bolt-Shoulder
13	105-0379-03	1	Panel-Side, LH
14	100-1280-03	1	Support-Side Panel, RH
15	95-3989	4	Mount-Sidepanel
16	95-1726	6	Screw-Taptite W/Patch
17	100-1281-03	1	Support-Side Panel, LH
18	46-8093	4	Screw-Plastite
19	105-0395	1	Heat Shield ASM
19:2	80-8290	1	Plate-Surface, Hot
19:3	3269-31	2	Rivet-Pop
20	3230-28	2	Screw-CARR
21	3296-29	1	Nut-Lock, NI

Ref. No.	Part No.	Qty.	Description
22	100-1655	1	Grip-Handle
23	100-4223	1	Handle-Latch
24	322-2	1	Screw-HH

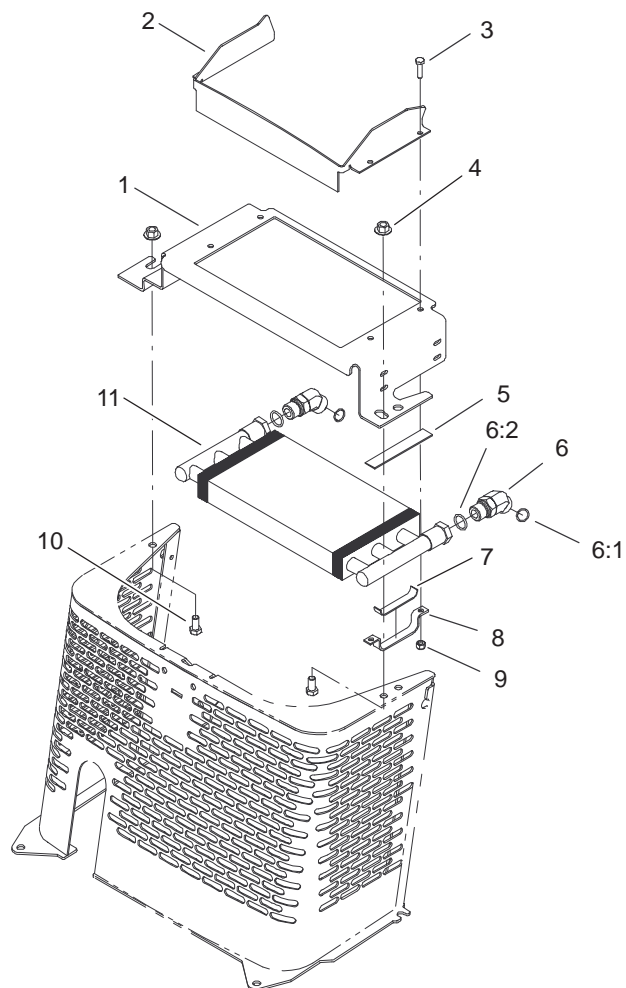

Sheet No.: 19

Hydraulic Cooler Assembly

Ref. No.	Part No.	Qty.	Description	Ref. No.	Part No.	Qty.	Description
1	104-2801-03	1	Bracket-Cooler				
2	104-2802-03	1	Shield-Cooler				
3	321-6	4	Screw-HH				
4	32128-43	3	Nut-Flange				
5	94-9566	2	Pad-Footrest				
6	340-14	2	Fitting-HYD, 45°				
6:1	237-65	1	O-Ring				
6:2	237-80	1	O-Ring				
7	104-2816	2	Pad-Support				
8	104-2803	2	Support-Cooler				
9	3296-42	4	Nut-Lock, NI				
10	323-4	3	Screw-HH				
11	105-0352	1	Exchanger-Heat				

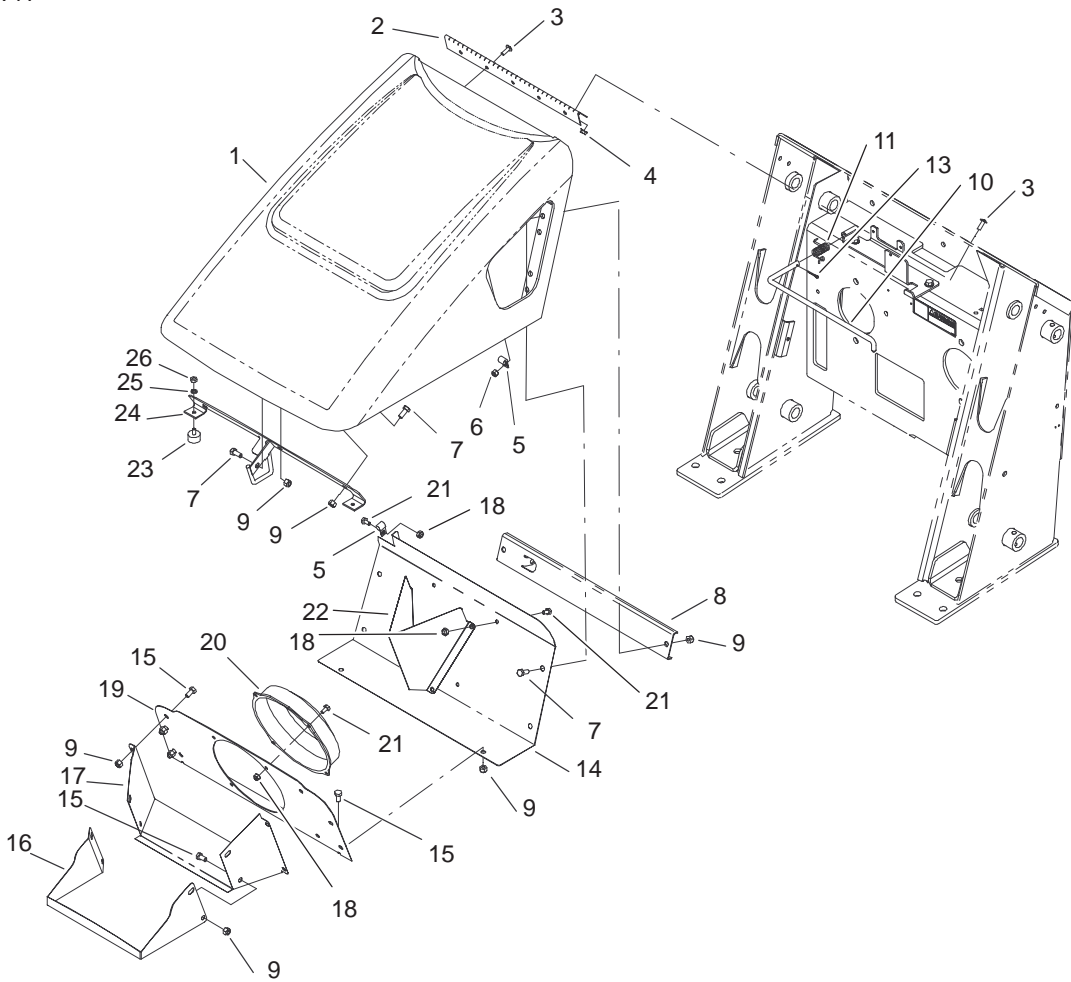

Sheet No.: 20

Hood Assembly

Ref. No.	Part No.	Qty.	Description
1	106-2590	1	Engine Hood ASM
2	100-1284	1	Hinge-Hood
3	9114604	9	Screw-Head, Truss
4	32128-33	4	Nut-HF
5	2412-91	2	Clamp
6	3296-42	5	Nut-Lock, NI
7	322-3	14	Screw-HH
8	106-2555-03	1	Bracket-Support, Hood
9	3296-29	22	Nut-Lock, NI
10	106-2554	1	Rod-Support, Hood
11	106-2584	1	Spring-Torsion
13	3272-6	1	Pin-Cotter
14	106-2596-03	1	Bracket-Fan, Back
15	322-2	8	Screw-HH
16	104-2813-03	1	Shroud-Fan, Front
17	106-2597-03	1	Shroud-Fan
18	3296-16	9	Nut-Lock, NI
19	106-2595-03	1	Bracket-Baffle, Fan
20	104-2809	1	Fan-12v
21	321-2	9	Screw-HH
22	104-2811-03	1	Baffle-Fan
23	240-14	2	Bumper-Rubber
24	100-1297-03	1	Rod Latch ASM
25	3253-3	2	Washer-Lock
26	3217-5	2	Nut-Hex

Ref. No.	Part No.	Qty.	Description

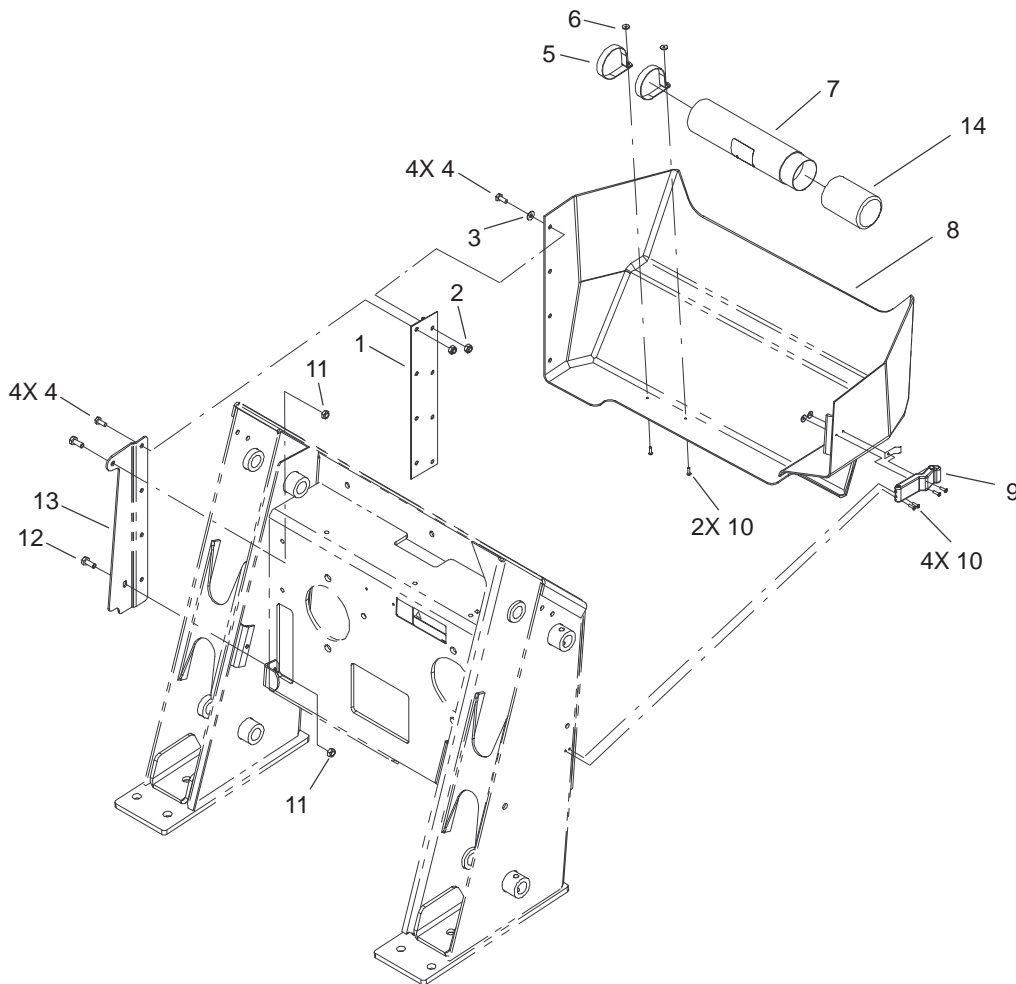

Sheet No.: 21

Rear Access Panel Assembly

Ref. No.	Part No.	Qty.	Description
1	100-1290	1	Hinge-Cover
2	3296-16	8	Nut-Lock, NI
3	3256-1	4	Washer-Flat
4	321-39	8	Screw-HH
5	2412-120	2	R-Clamp
6	3269-10	4	Washer-Back
7	104-7050	1	Housing-Manual
8	100-1288	1	Cover-Back
9	80-6980	1	Latch
10	3269-17	8	Rivet-Pop
11	3296-47	2	Nut-Lock, NI
12	322-3	2	Screw-HH
13	100-1289-01	1	Bracket-Hinge, Cover
14	104-7048	1	Cap-Housing

Ref. No.	Part No.	Qty.	Description

Electrical Schematic

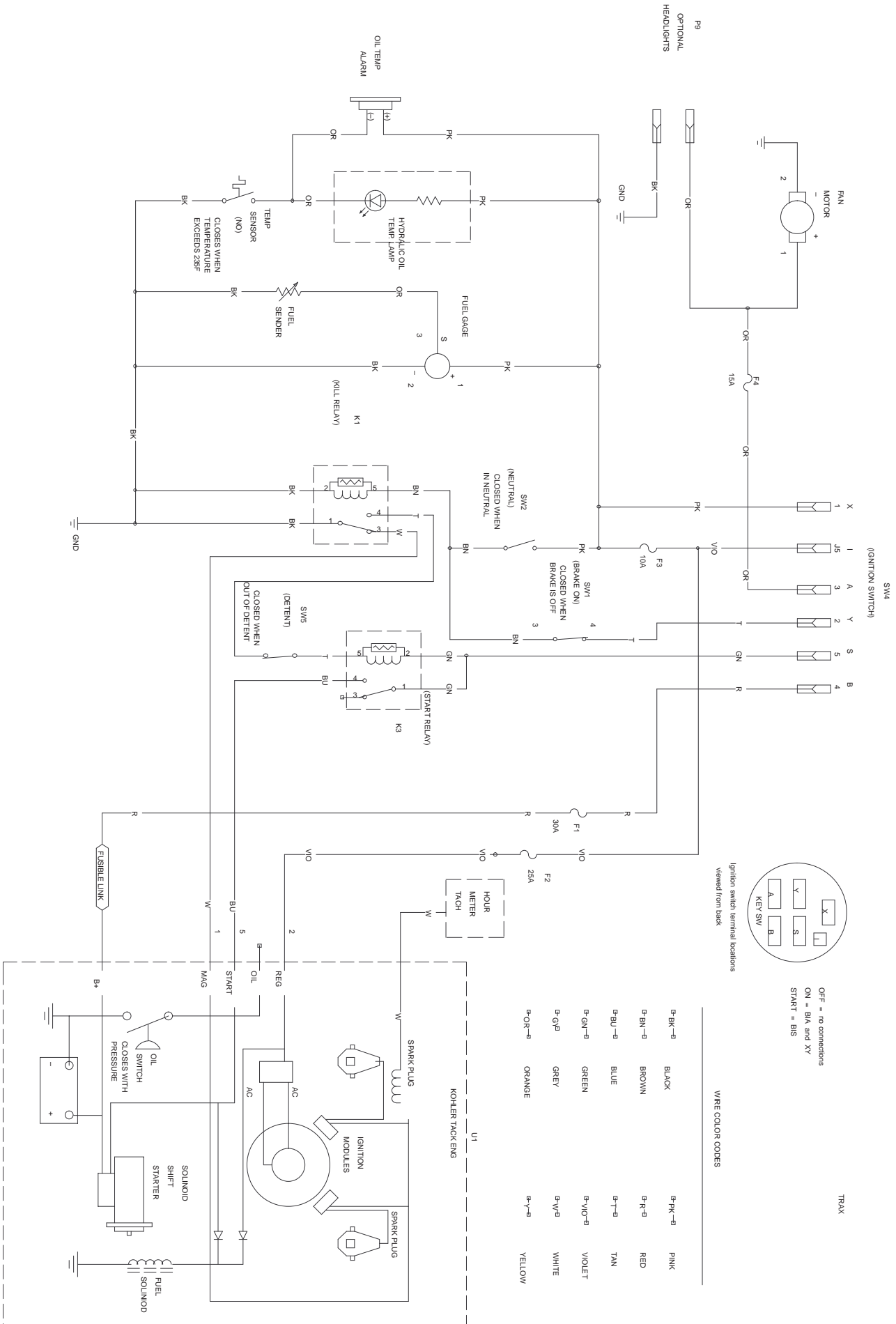

Hydraulic Schematic

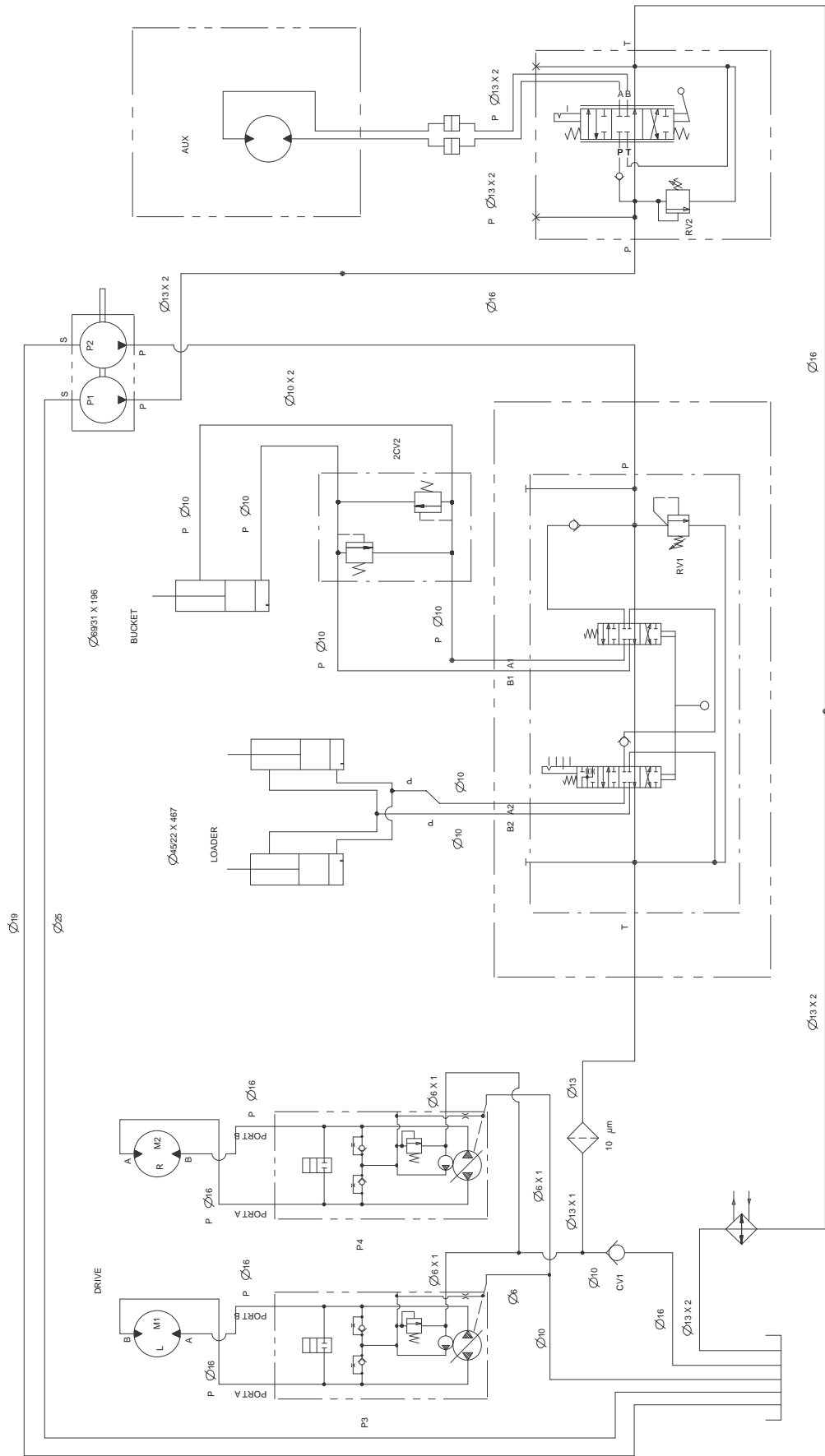

DISPLACEMENT A		ND PRESSURE CHART				
COMPONENT	DISPLACEMENT	PRESSURE		FLOWRATE*		
COMPONENT	CU IN/REV	CU CM/REV	PSI	BAR	GPM	LPM
* P1	0.73 CU IN	12 CC			11.2	42.4
* P2	0.96 CU IN	6 CC			5.5	21.0
M1, M2	32.5 CU IN	528 CC				
** P3/P4	0-1.28 CU IN	21 CC			17	64
RV1			2400 PSI	166 BAR		
RV2			3000 PSI	207 BAR		
CV1			5 PSI	35 BAR		
2CV2			3000 PSI	207 BAR		

* FLOWRATE CALCULATED AT 3600 RPM/A
 ** FLOWRATE CALCULATED AT 3100 RPM/A
 ND 98% EFFICIENCY
 ND 98% EFFICIENCY

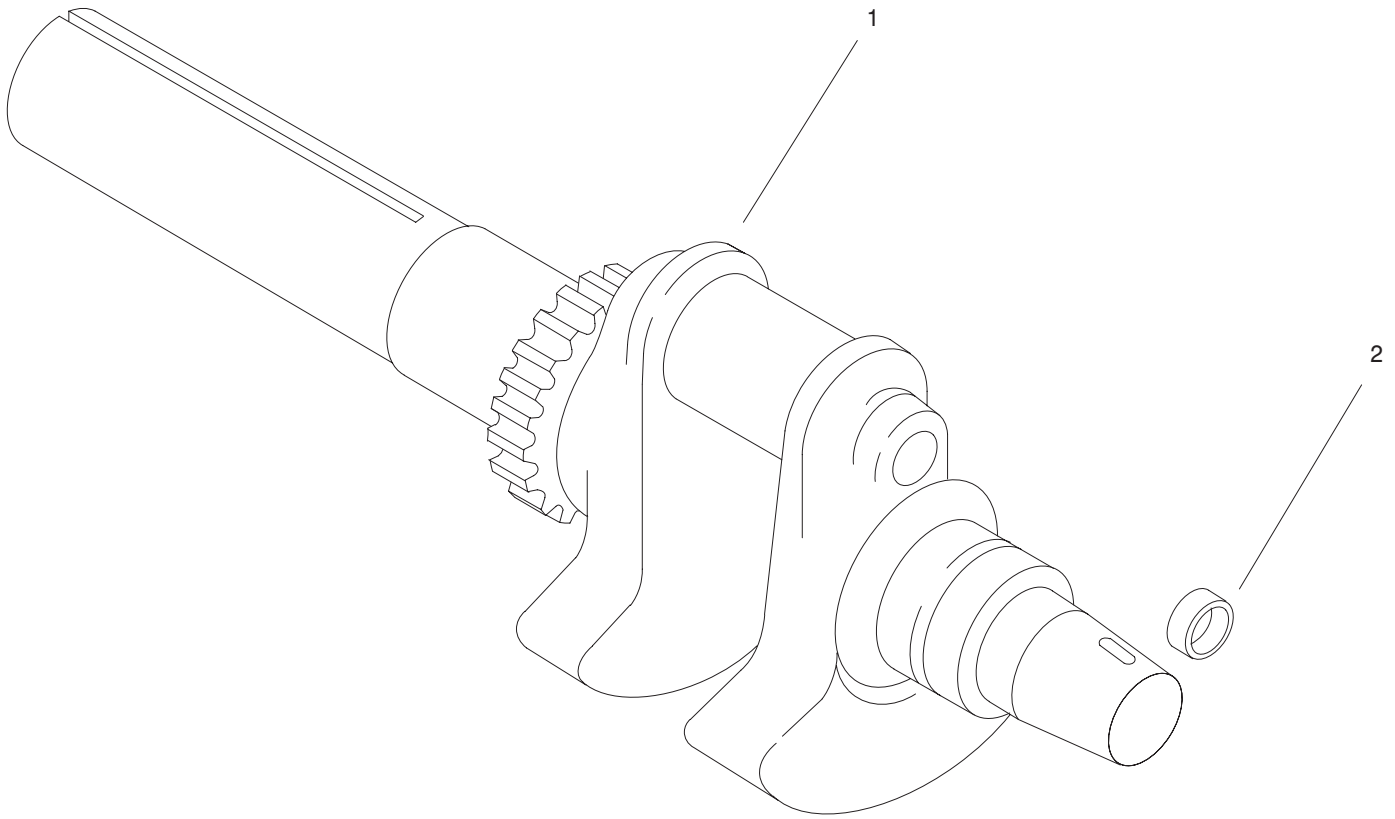

Group 1 – Crankshaft Assembly Kohler CH20S-64656

Ref. No.	Part No.	Qty.	Description
1	24 014 90-S	1	Crankshaft
2	52 139 09-S	1	Plug, cup

Ref. No.	Part No.	Qty.	Description

Obtain Parts from Kohler

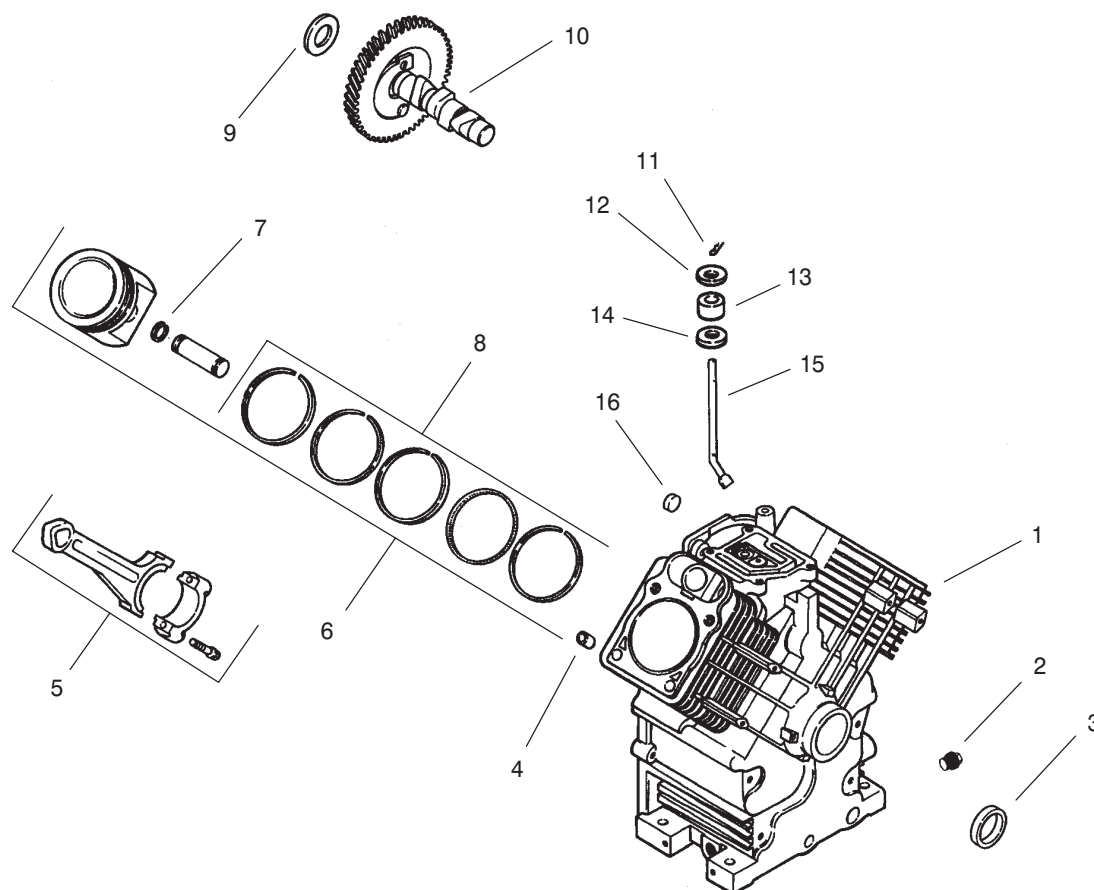

Group 2 – Crankcase Assembly Kohler CH20S-64656

Ref. No.	Part No.	Qty.	Description	Ref. No.	Part No.	Qty.	Description
1		1	Crankcase (Use Miniblock 24 782 15)				
2	52 139 02-S	2	Plug, pipe	10	24 012 10-S	1	Camshaft
3	24 032 01-S	1	Seal, oil front	11	24 018 09-S	1	Retaining, Ring
4	12 380 13-S	6	Pin, dowel locating	12	M-931010-S	1	Washer, Nylon
5	24 067 13-S	2	Connecting Rod (Std.)	13	28 032 09-S	1	Seal, governor cross shaft
	24 067 14-S	2	Connecting Rod (.25)	14	24 468 15-S	1	Washer
6	24 874 01-S	2	Piston w/Ring Set (Std.)	15	24 144 33-S	1	Shaft, governor cross
	24 874 02-S	2	Piston w/Ring Set (.25)	16	52 139 09-S	1	Plug, cup
	24 874 03-S	2	Piston w/Ring Set (.50)				
	24 874 14-S	2	Piston w/Ring Set (.08)				
7	24 018 01-S	4	Retainer, piston pin				
8	24 108 01-S	2	Ring Set (Std.)				
	24 108 02-S	2	Ring Set (.25)				
	24 108 03-S	2	Ring Set (.50)				
9	12 422 09-S	A/R	Shim, camshaft – red				
	12 422 13-S	A/R	Shim, camshaft – black				
	12 422 07-S	A/R	Shim, camshaft – white				
	12 422 08-S	A/R	Shim, camshaft – blue				
	12 422 10-S	A/R	Shim, camshaft – yellow				
	12 422 11-S	A/R	Shim, camshaft – green				

Obtain Parts from Kohler

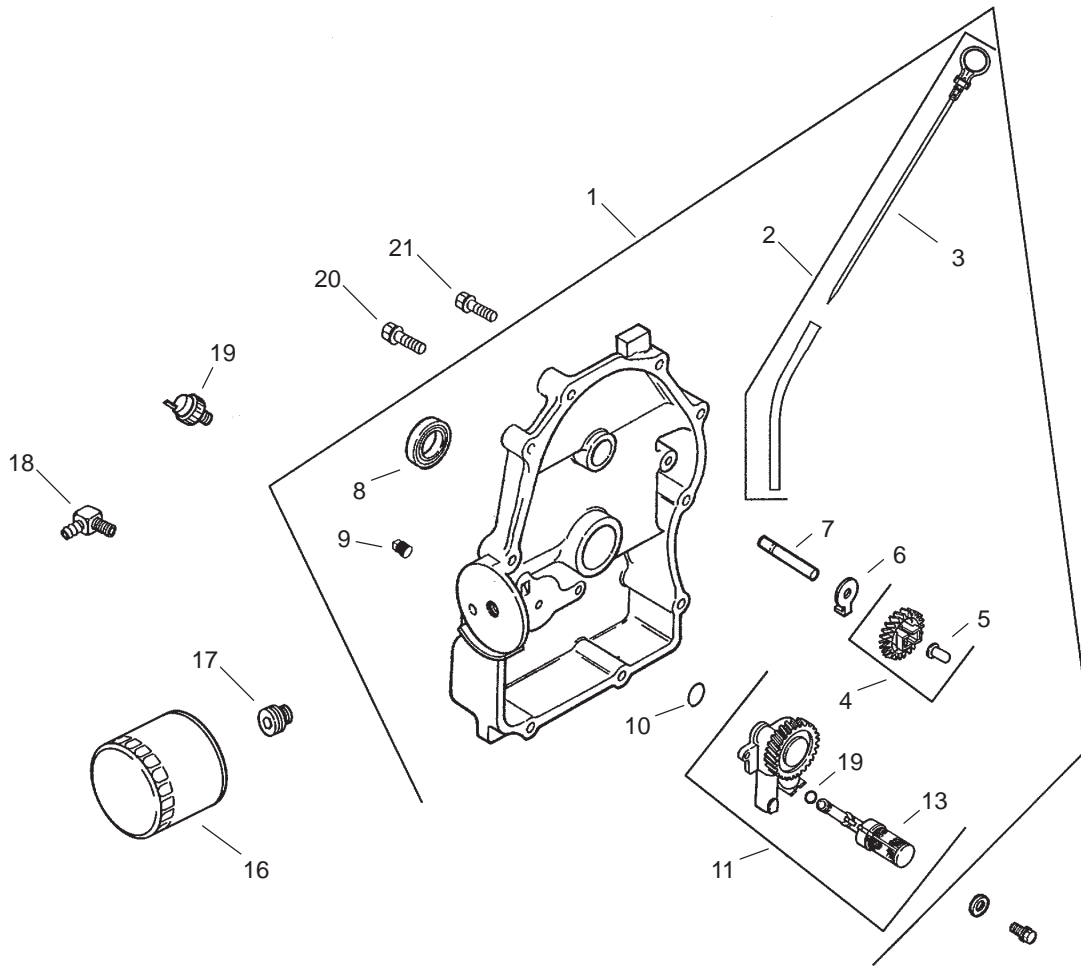

Group 3 – Oil Pan/Lubrication Assembly Kohler CH20S-64656

Ref. No.	Part No.	Qty.	Description
1	24 009 92-S	1	Plate, Closure ASM (Includes 2-13)
2	24 755 121-S	1	Dipstick & Tube Kit (Includes 3)
3	24 038 10-S	1	Dipstick
4	24 043 12-S	1	Kit, governor gear (Includes 5)
5	12 380 01-S	1	Pin, governor regulating
6	52 448 02-S	1	Tab, locking
7	12 144 02-S	1	Shaft, governor gear
8	52 032 08-S	1	Seal, oil (PTO end)
9	X-75-23-S	2	Plug, pipe 1/8"
10	24 153 08-S	1	O-Ring
11	24 393 10-S	1	Oil pump assembly (Includes 12,13)
12	24 153 01-S	1	O-Ring, oil pick-up
13	24 381 04-S	1	Pick-up, oil
14	M-631005-S	2	Washer, plain 6 mm
15	M-645025-S	2	Screw, hex flange
16	52 050 02-S	1	Filter, oil
17	24 136 01-S	1	Nipple, oil filter
18	25 155 02-S	1	Connector
19	24 099 03-S	1	Switch, pressure

Ref. No.	Part No.	Qty.	Description
20	24 086 16-S	9	Screw, hex flange
21	24 086 17-S	1	Screw, hex flange

Obtain Parts from Kohler

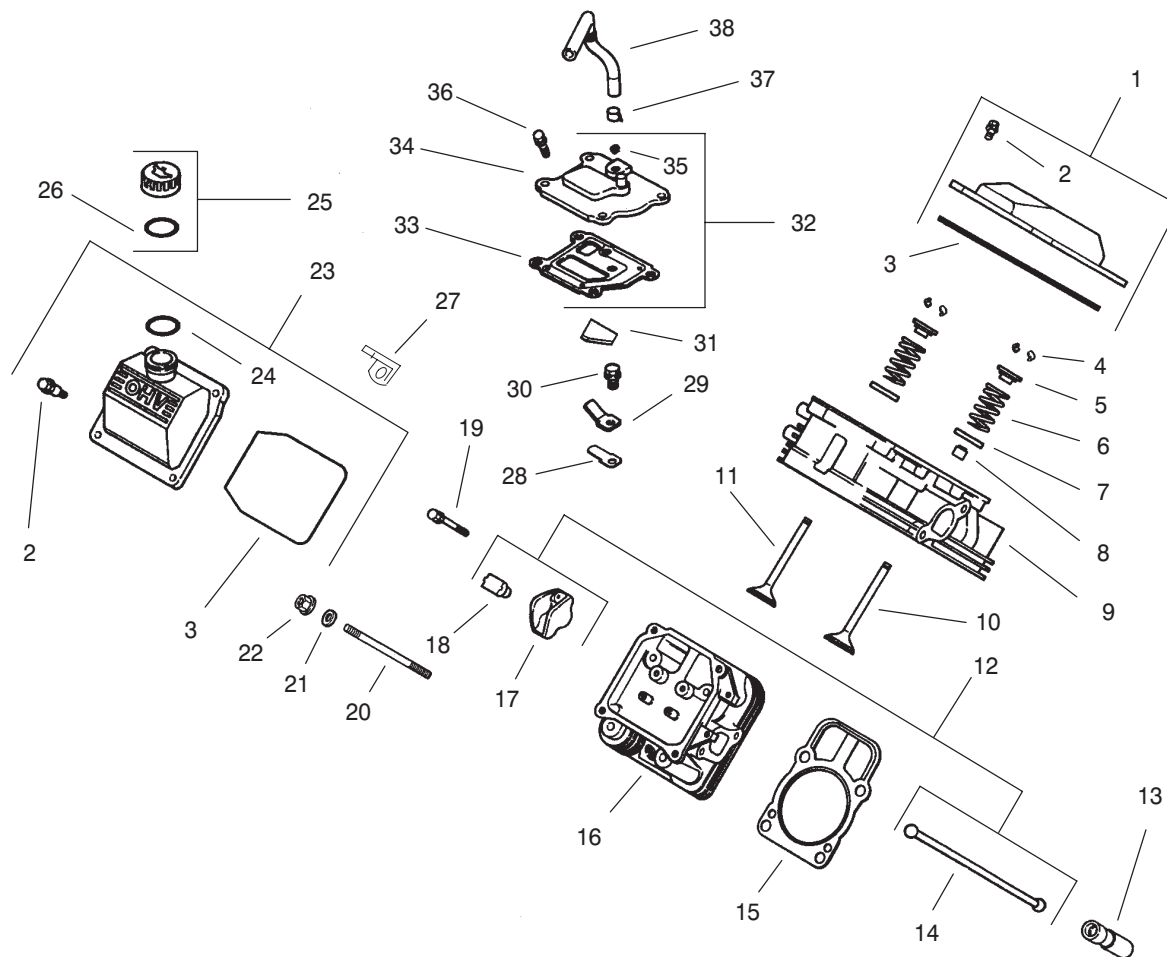

Group 4 – Head/Valve/Breather Assembly Kohler CH20S-64656

Ref. No.	Part No.	Qty.	Description	Ref. No.	Part No.	Qty.	Description
1	24 755 74-S	1	Kit, valve cover – plain (Includes 2-3)	19	M-640034-S	4	Screw, hex. flange
2	24 086 32-S	4	Screw, shoulder	20	24 072 09-S	1	Stud, Cyl. Head
3	24 153 16-S	1	O-Ring, valve cover	21	24 468 16-S	1	Washer, Flat
4	12 755 03-S	4	Kit, retainer	22	24 100 10-S	1	Nut-HF
5	12 173 01-S	4	Cap, valve spring	23	24 755 75-S	1	Kit, valve cover – oil fill (Includes 2,3,23)
6	24 089 02-S	4	Spring, valve	24	24 153 09-S	1	O-Ring
7	235011-S	4	Retainer, spring	25	24 755 46-S	1	Kit, oil fill cap (Includes 24)
8	24 032 05-S	2	Seal, valve stem	26	12 153 03-S	1	O-Ring, oil fill cap
9	24 318 68-S	1	Head assembly, #1 cylinder	27	24 445 01-S	1	Strap, Lifting
10	24 017 01-S	2	Valve, intake (Std.)	28	24 402 03-S	1	Reed, breather
	24 017 02-S	2	Valve, intake (.25)	29	12 018 01-S	1	Retainer, breather reed
11	24 016 01-S	2	Valve, exhaust (Std.)	30	M-545010-S	1	Screw, hex. flange
	24 016 02-S	2	Valve, exhaust (.25)	31	24 050 01-S	1	Filter, breather
12	24 755 66-S	1	Kit, valve train (Includes 15,18,19)	32	24 033 01-S	1	Kit, breather (Includes 33-35)
13	12 351 01-S	4	Lifter, valve	33	24 041 23-S	1	Gasket, breather
14	24 411 05-S	4	Rod, push	34	24 096 58-S	1	Cover, breather
15	24 041 08-S	2	Gasket, cylinder head	35	X-75-23-S	1	Plug, allen head pipe
16	24 318 71-S	1	Head assembly, #2 cylinder	36	M-645020-S	4	Screw, hex. flange
17	25 186 01-S	4	Arm, rocker	37	X-426-9-S	1	Clamp, breather
18	24 599 01-S	4	Pivot, rocker arm	38	24 326 26-S	1	Hose, breather

Obtain Parts from Kohler

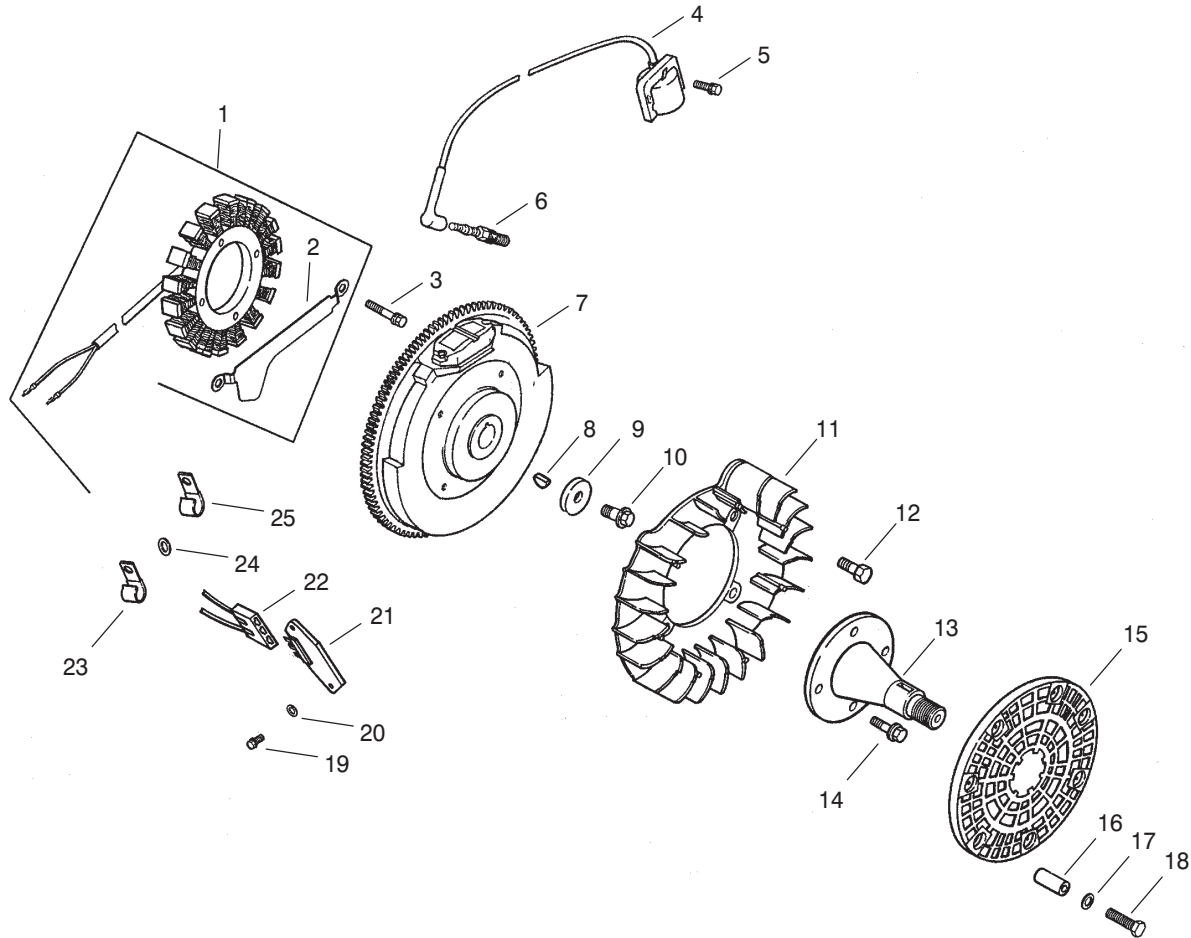

Group 5 – Ignition/Electrical Assembly Kohler CH20S-64656

Ref. No.	Part No.	Qty.	Description
1	54 755 09-S	1	Kit, 15 amp stator (Includes 2)
2	24 126 71-S	1	Bracket, stator wire
3	M-548025-S	2	Screw, hex. cap
4	24 584 01-S	2	Module, ignition
5	M-545020-S	4	Screw, hex. flange
6	12 132 06-S	2	Spark Plug
7	24 025 01-S	1	Flywheel
8	X-42-15-S	1	Key
9	12 468 03-S	1	Washer, plain 3/8"
10	12 086 14-S	1	Screw, hex flange
11	24 157 03-S	1	Fan
12	25 086 47-S	4	Bolt, shoulder
13	24 144 13-S	1	Shaft, front drive
14	M-839025-S	4	Screw, hex flange
15	24 162 18-S	1	Screen, grass
16	24 122 04-S	4	Spacer
17	X-25-92-S	2	Washer, plain 3/16
18	M-403025-S	4	Screw
19	24 086 18-S	2	Screw, phillips hd.
20	X-25-92-S	2	Washer
21	25 403 03-S	1	Rectifier-regulator 15 amp
22	236602-S	1	Connector

Ref. No.	Part No.	Qty.	Description
23	235173-S	1	Clip, cable
24	X-25-63-S	1	Washer, plain 1/4"
25	48 154 02-S	1	Clip, cable
*	25 518 12-S	1	Lead, black, (4" – 18 gauge – insulated grip barrel eyelet terminals)
*	25 086 91-S	1	Screw, sems hex cap (used to mount terminal on wiring harness to baffle
*	24 176 08-S	1	Harness, wiring
*	X-22-11-S	1	Washer, lock
*	25 454 03-S	2	Tie, cable

Obtain Parts from Kohler

* Not illustrated

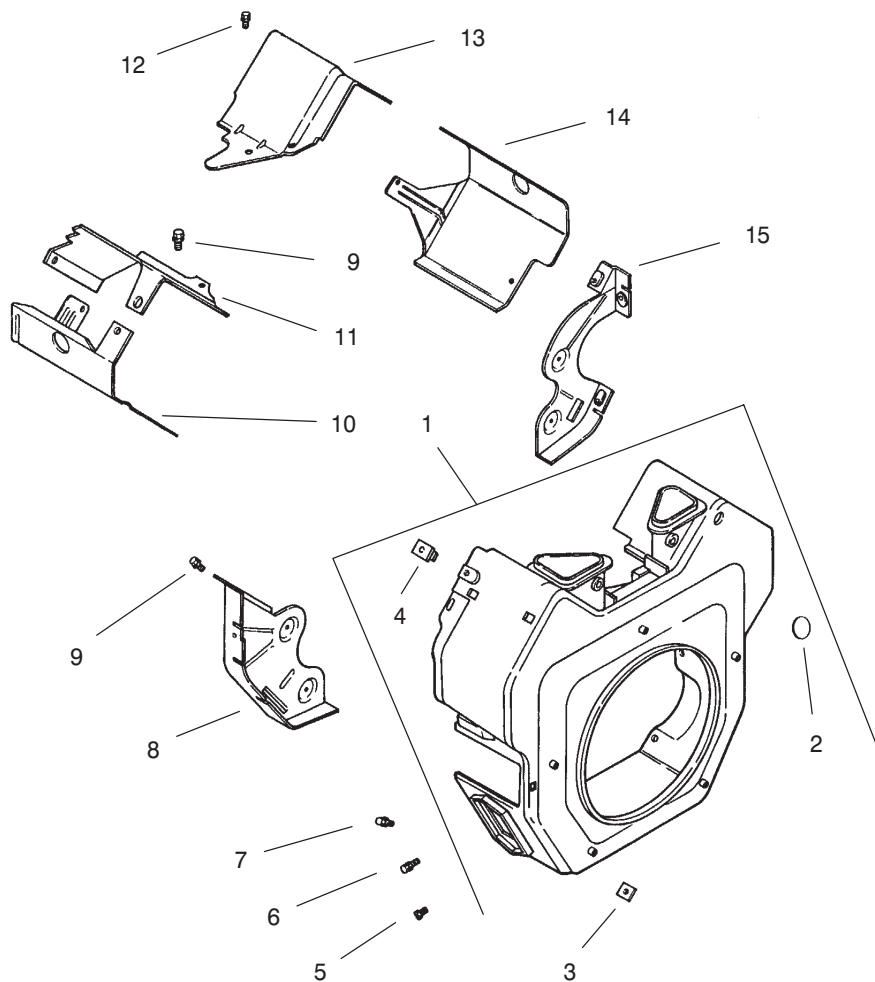

Group 6 – Blower Housing Assembly Kohler CH20S-64656

Ref. No.	Part No.	Qty.	Description	Ref. No.	Part No.	Qty.	Description
1	24 027 20-S	1	Housing, blower (Includes 2-4)				
2	25 139 16-S	1	Plug, button 9/16"				
3	24 100 01-S	3	Nut, plastic				
4	24 100 02-S	2	Nut, plastic				
5	M-551016-S	1	Screw, hex. flange				
6	M-545016-S	3	Screw, hex. flange				
7	M-545020-S	4	Screw, hex. flange				
8	24 146 16-S	1	Plate, backing - #2 side				
9	M-645016-S	6	Screw, hex. flange				
10	24 063 20-S	1	Baffle, cyl. barrel-#2 side				
11	24 063 17-S	1	Baffle, valley - #2 side				
12	M-545010-S	2	Screw, hex. flange				
13	24 063 24-S	1	Baffle, valley - #1 side				
14	24 063 58-S	1	Baffle, cyl. barrel-#1 side				
15	24 146 20-S	1	Plate, backing - #1 side				
*	24 113 95-S	1	Decal, HP				

Obtain Parts from Kohler

* Not illustrated

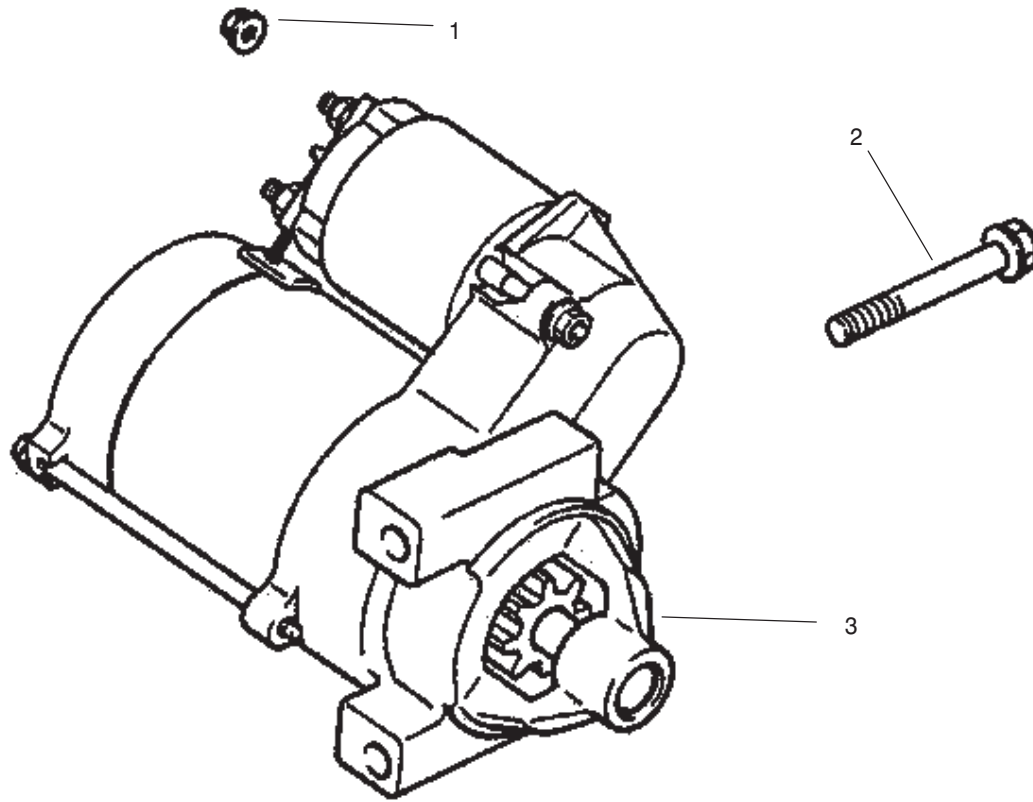

Group 7 – Starter Assembly Kohler CH20S-64656

Ref. No.	Part No.	Qty.	Description
1	M-841080-S	1	Nut, hex flange
2	M-839080-S	2	Screw, hex. flange
3	24 098 08-S	1	Starter, solenoid shift ASM (Service with kits listed below)
*	25 755 33-S	1	Kit, pinion drive (Incl. Ring 24 141 01-S)
*	25 221 01-S	1	Kit, brush
*	25 435 04-S	1	Kit, Solenoid

Ref. No.	Part No.	Qty.	Description

Obtain Parts from Kohler

* Not illustrated

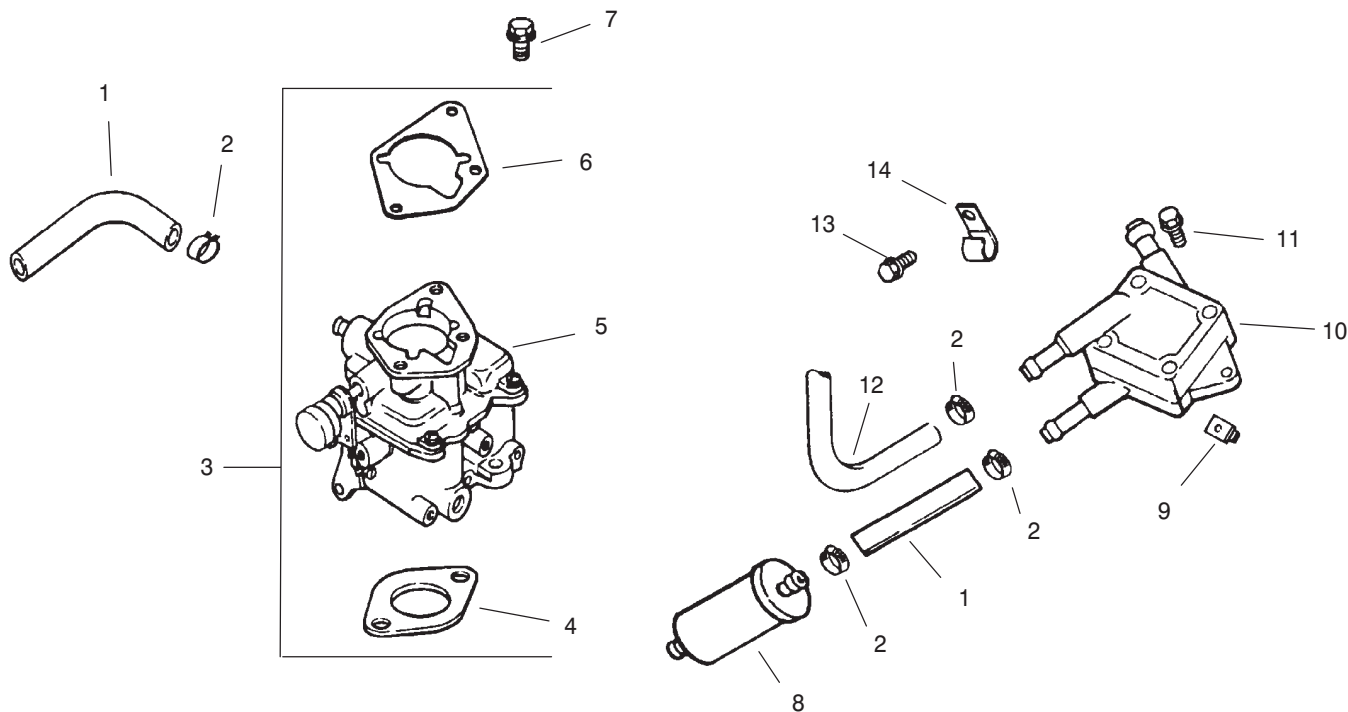

Group 8 – Fuel System Assembly Kohler CH20S-64656

Ref. No.	Part No.	Qty.	Description
1	25 353 32-S	2	Line, fuel – 9"
2	25 237 14-S	6	Clamp, hose
3	24 853 32-S	1	Kit, carburetor w/gasket (Incl. 4-6)
4	24 041 06-S	1	Gasket, air cleaner
5	24 053 32-S	1	Carburetor assembly (For information only not available separate Includes 24 757 01-S, 24 757 02-S, 24 757 03S & 24 757 07-S)
6	24 041 17-S	1	Gasket, carburetor
7	M-651030-S	2	Screw, hex. flange
8	24 050 02-S	1	Filter, fuel
9	24 100 01-S	2	Nut, plastic
10	24 393 16-S	1	Pump, fuel-pulse
11	24 086 12-S	2	Screw, hex cap
12	24 353 02-S	1	Line, fuel 15-1/2"
13	M-650012-S	1	Screw, hex flange
14	47 154 01-S	1	Clip, cable
*	24 757 01-S	1	Kit, solenoid (Includes solenoid 24 521 01-S, O-Ring 24 153 04-S, O-Ring 24 153 05-S,

Ref. No.	Part No.	Qty.	Description
			O-Ring 24 153 06-S, Solenoid screw 24 086 07-S, & Solenoid 24 435 01-S)
*	24 757 02-S	1	Kit-Float
*	24 757 07-S	1	Kit, choke (Includes choke lever cap 24 173 02-S)
*	24 757 03-S	1	Kit, carburetor repair (Includes inlet needle valve clip 24 154 01-S, inlet needle valve 24 462 01-S, carburetor body screw 24 086 09-S, carburetor body gasket 24 041 09-S, slow O-Ring 24 153 02-S, O-Ring 24 13 04-S, O-Ring 24 153 05-S, O-Ring 24 153 06-S, idle needle 24 368 01-S, & idle needle spring 24 089 11-S)

Obtain Parts from Kohler

* Not illustrated

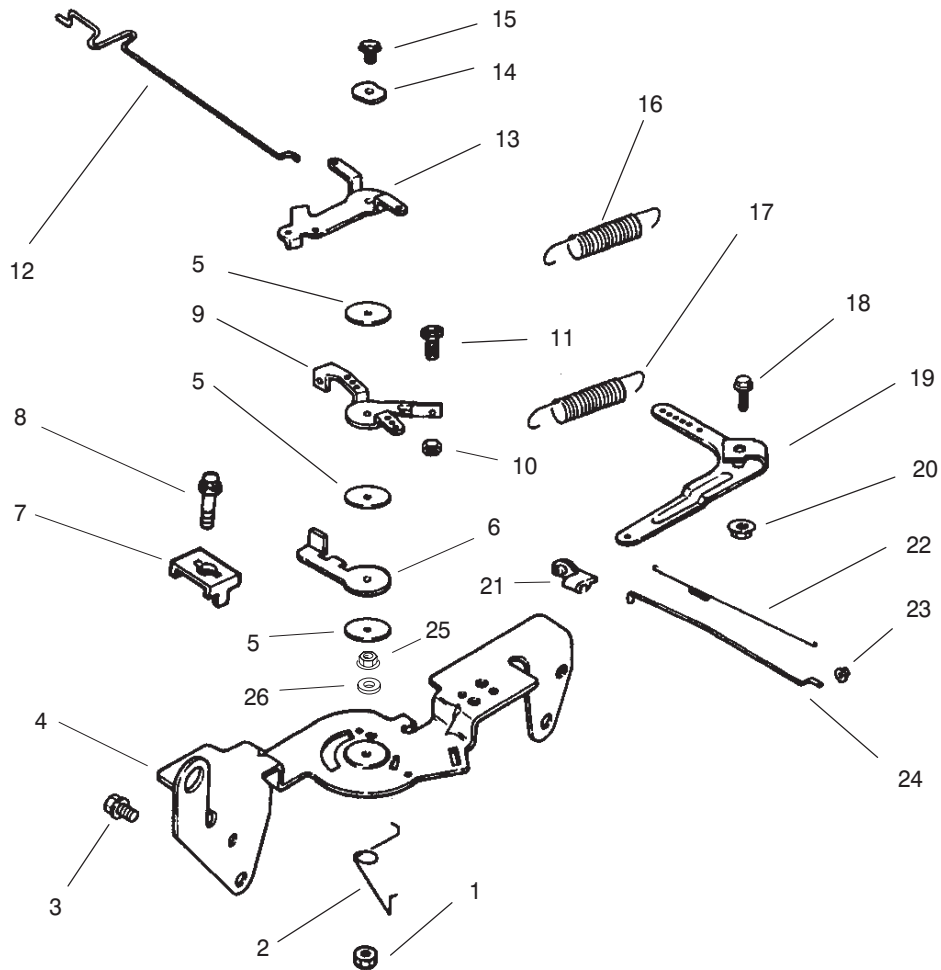

Group 9 – Engine Control Assembly Kohler CH20S-64656

Ref. No.	Part No.	Qty.	Description
1	M-547050-S	1	Nut, hex. lock
2	24 089 03-S	1	Spring, choke return
3	M-645016-S	4	Screw, hex. flange
4	24 126 56-S	1	Bracket, control
5	24 468 01-S	3	Washer, plain
6	24 090 07-S	1	Lever, throttle actuator
7	12 237 01-S	2	Clamp, cable
8	M-545016-S	2	Screw, hex. flange
9	24 090 03-S	1	Lever, throttle control
10	M-446030-S	1	Nut, hex
11	M-401030-S	1	Screw, hex. cap
12	24 079 02-S	1	Linkage, choke
13	24 090 05-S	1	Lever, choke
14	41 468 03-S	1	Washer, spring
15	M-545020-S	1	Screw, hex. flange
16	24 089 51-S	1	Spring, throttle limiter
17	24 089 46-S	1	Spring, governor
18	24 211 03-S	1	Screw, hex. flange
19	24 090 33-S	1	Lever, governor
20	M-641060-S	1	Nut, hex. flange
21	25 158 11-S	1	Bushing, linkage retaining
22	24 089 01-S	1	Spring, linkage
23	25 158 08-S	1	Bushing, linkage

Ref. No.	Part No.	Qty.	Description
24	24 079 01-S	1	retaining Linkage, throttle
25	M-545010-S	1	Nut-HF
26	X-20-1-S	1	Washer, Lock

Obtain Parts from Kohler

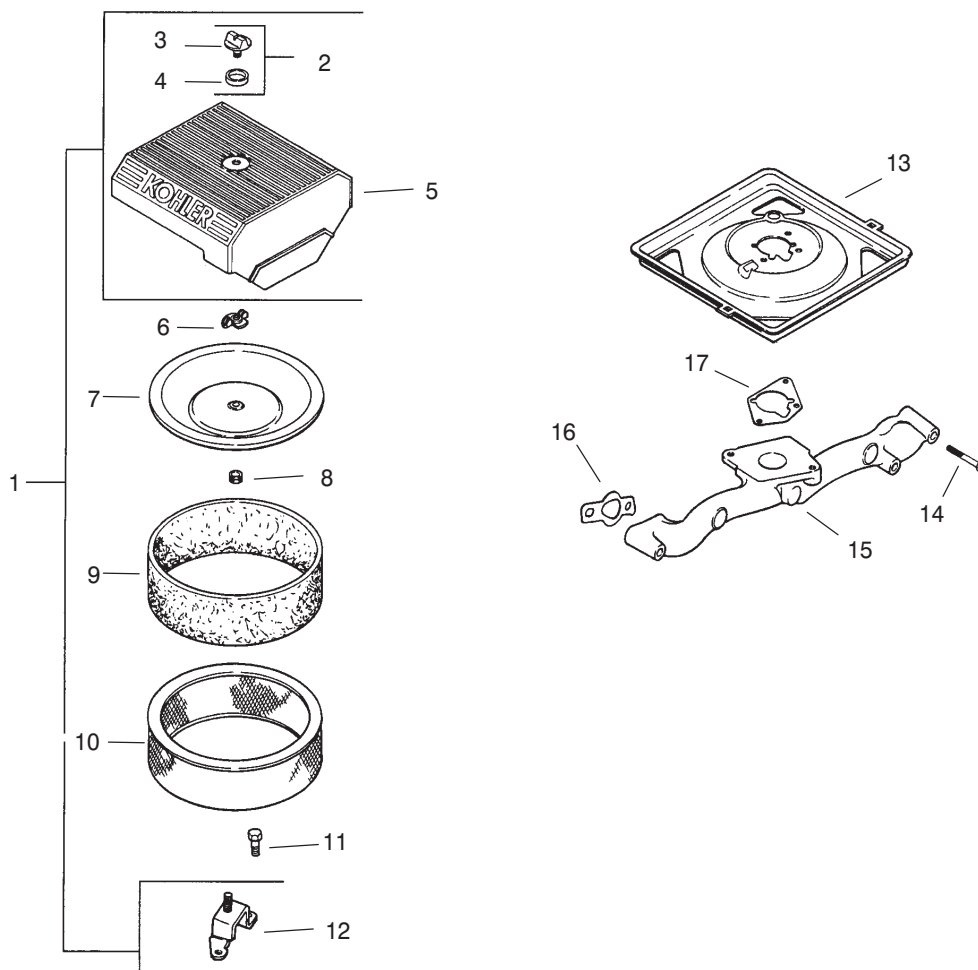

Group 10 – Air Intake/Filtration Assembly Kohler CH20S-64656

Ref. No.	Part No.	Qty.	Description
1	24 743 05-S	1	Kit, air cleaner (Includes 2-5, 12)
2	54 755 01-S	1	Kit, air cleaner knob (Includes 3,4)
3	25 341 03-S	1	Knob, cover
4	24 153 20-S	1	O-Ring
5	24 096 67-S	1	Cover, air cleaner
6	12 100 01-S	1	Wing Nut
7	24 096 01-S	1	Cover, inner air cleaner
8	24 032 03-S	1	Seal, inner air cleaner
9	24 083 02-S	1	Precleaner, element
10	47 883 03-S	1	Air Filter Assembly (Includes 9)
11	M-639016-S	3	Screw, hex flange
12	24 126 21-S	1	Bracket, air cleaner base

Ref. No.	Part No.	Qty.	Description
13	24 094 03-S	1	Base, air cleaner
14	M-651055-S	4	Screw, hex flange
15	24 164 14-S	1	Manifold, intake
16	24 041 01-S	2	Gasket, intake manifold
17	24 041 06-S	1	Gasket, air cleaner base

Obtain Parts from Kohler

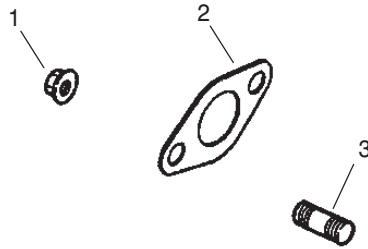

Group 11 – Exhaust Assembly Kohler CH20S-64656

Ref. No.	Part No.	Qty.	Description	Ref. No.	Part No.	Qty.	Description
1	M-841080-S	4	Nut, hex flange				
2	24 041 02-S	2	Gasket, exhaust				
3	25 072 04-S	4	Stud				
*	24 782 15	1	Miniblock				
*	24 755 107-S	1	Gasket Set				

Obtain Parts from Kohler

* Not illustrated

Maintenance Record

Date								

