



**Count on it.**

**Operator's Manual**

# Flex-Force Power System<sup>®</sup> 60V Cordless Power Shovel<sup>™</sup>

Model No. 39909—Serial No. 324000581 and Up

Model No. 39909T—Serial No. 324000101 and Up

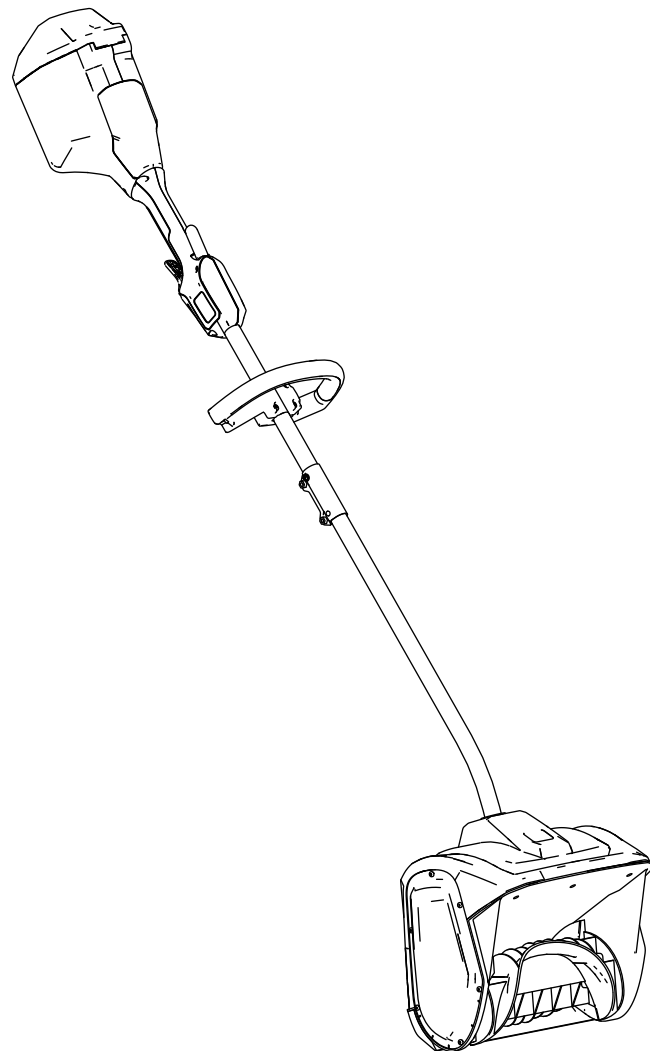



**For assistance, please see [www.Toro.com/support](http://www.Toro.com/support) for instructional resources or contact 1-888-384-9939 before returning this product.**

**⚠ WARNING**

**CALIFORNIA  
Proposition 65 Warning**

**The power cord on this product contains lead, a chemical known to the State of California to cause birth defects or other reproductive harm. Wash hands after handling.**

**Use of this product may cause exposure to chemicals known to the State of California to cause cancer, birth defects, or other reproductive harm.**

# Introduction

This product is intended to be used by residential homeowners. It is designed for removing up to 15 cm (6 inches) of snow from patios, sidewalks, and small driveways. It is not designed for removing materials other than snow, nor is it designed for clearing off gravel surfaces. It is to be used only by adults. It is designed to use Flex-Force 60V lithium-ion battery packs. These battery packs are designed to be charged only by Flex-Force 60V lithium-ion battery chargers. Using these products for purposes other than their intended use could prove dangerous to you and bystanders.

**Model 39909T does not include a battery or a charger.**

Read this information carefully to learn how to operate and maintain your product properly and to avoid injury and product damage. You are responsible for operating the product properly and safely.

Visit [www.Toro.com](http://www.Toro.com) for more information, including safety tips, training materials, accessory information, help finding a dealer, or to register your product.

Whenever you need service, genuine Toro parts, or additional information, contact an Authorized Service Dealer or Toro Customer Service and have the model and serial numbers of your product ready. [Figure 1](#) identifies the location of the model and serial numbers on the product. Write the numbers in the space provided.

**Important:** With your mobile device, you can scan the QR code (if equipped) on the serial number plate to access warranty, parts, and other product information.

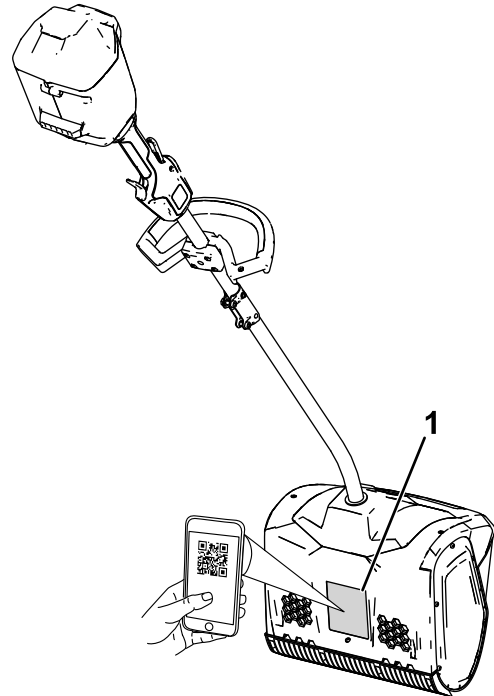

**Figure 1**

1. Model and serial number location.

Model No.	_____
Serial No.	_____

# Safety-Alert Symbol

The safety-alert symbol (Figure 2) shown in this manual and on the machine identifies important safety messages that you must follow to prevent accidents.



g000502

**Figure 2**  
Safety-alert symbol

---

The safety-alert symbol appears above information that alerts you to unsafe actions or situations and is followed by the word **DANGER**, **WARNING**, or **CAUTION**.

**DANGER** indicates an imminently hazardous situation which, if not avoided, **will** result in death or serious injury.

**WARNING** indicates a potentially hazardous situation which, if not avoided, **could** result in death or serious injury.

**CAUTION** indicates a potentially hazardous situation which, if not avoided, **may** result in minor or moderate injury.

This manual uses two other words to highlight information. **Important** calls attention to special mechanical information and **Note** emphasizes general information worthy of special attention.

# Contents

Safety-Alert Symbol.....	3
Safety .....	4
.....	4
Safety and Instructional Decals .....	6
Setup .....	8
Mounting the Battery Charger (Optional).....	8
Unfolding the Handle .....	9
Installing the Auxiliary Handle .....	10
Product Overview .....	11
Specifications .....	11
Attachments/Accessories .....	11
Operation .....	12
Starting the Machine.....	12
Shutting Off the Machine .....	12
Removing the Battery Pack .....	12
Charging the Battery Pack .....	13
Operating Tips .....	13
Maintenance .....	14
Replacing the Scraper Blade .....	14
Preparing the Battery Pack for Recycling .....	14
Service .....	14
Storage .....	15
Troubleshooting .....	16

# Safety

## IMPORTANT SAFETY INSTRUCTIONS

### **▲ WARNING**

**When using an electric machine, always read and follow basic safety warnings and instructions to reduce the risk of fire, electric shock, or injury, including the following:**

### **Read All Instructions**

#### **I. Training**

1. The operator of the machine is responsible for any accidents or hazards occurring to others or their property.
2. Read and understand the contents of this *Operator's Manual* before you start the machine. Ensure that everyone using this machine knows how to use it, knows how to shut it off quickly, and understands the warnings.
3. Do not allow children to use or play with the machine, battery pack, or the battery charger; local regulations may restrict the age of the operator.
4. Do not allow children or untrained people to operate or service this device. Allow only people who are responsible, trained, familiar with the instructions, and physically capable to operate or service the device.
5. Before using the machine, battery pack, and battery charger, read all the instructions and cautionary markings on these products.
6. Become familiar with the controls and proper use of the machine, battery pack, and battery charger.

#### **II. Preparation**

1. Keep bystanders and children out of the operating area.
2. Never allow children to operate the machine.
3. Do not operate the machine without all guards and other safety devices in place and functioning properly on the machine.
4. Inspect the area where you will use the machine and remove all objects that could interfere with the operation of the machine or that the machine could throw.
5. Use only the battery pack specified by Toro. Using other accessories and attachments may increase the risk of injury and fire.

6. Plugging the battery charger into an outlet that is not 120 V can cause a fire or electric shock. Do not plug the battery charger into an outlet other than 120 V.
7. Do not use a damaged or modified battery pack or battery charger, which may exhibit unpredictable behavior that results in fire, explosion, or risk of injury.
8. If the supply cord to the battery charger is damaged, contact an Authorized Service Dealer to service or replace it.
9. Charge the battery pack with only the battery charger specified by Toro. A charger suitable for 1 type of battery pack may create a risk of fire when used with another battery pack.
10. Charge the battery pack in a well-ventilated area only.
11. Follow all charging instructions and do not charge the battery pack outside of the temperature range specified in the instructions. Otherwise, you may damage the battery pack and increase the risk of fire.
12. Dress properly—Wear appropriate clothing, including eye protection; long pants or trousers; substantial, slip-resistant rubber boots; and hearing protection. Tie back long hair and do not wear loose clothing or loose jewelry that can get caught in moving parts.

#### **III. Operation**

1. Contact with the moving rotor will cause serious injury. Keep your hands and feet away from all moving parts of the machine. Keep clear of any discharge opening.
2. Stay behind the rotor and away from the discharge opening while operating the machine.
3. Using this machine for purposes other than its intended use could prove dangerous to you and bystanders.
4. Prevent unintentional starting—Ensure that the switch is in the OFF position before connecting to the battery pack and handling the machine. Do not carry the machine with your finger on the switch or energize the machine with the switch in the ON position.
5. Use your full attention while operating the machine. Do not engage in any activity that causes distractions; otherwise, injury or property damage may occur.
6. Remove the battery pack from the machine, and wait for all movement to stop before adjusting, servicing, cleaning, or storing the machine.
7. Remove the battery pack from the machine whenever you leave it unattended or before changing accessories.

8. Do not force the machine—Allow the machine to do the job better and safer at the rate for which it was designed.
9. Stay alert—Watch what you are doing and use common sense when operating the machine. Do not use the machine while ill, tired, or under the influence of alcohol or drugs.
10. Operate the machine only in good visibility and appropriate weather conditions.
11. Use extreme caution when reversing or pulling the machine toward you.
12. Do not overreach—Keep proper footing and balance at all times, especially on slopes. Walk, never run with the machine.
13. When not actively clearing snow, disengage power to the auger.
14. Do not direct the discharge material toward anyone. Avoid discharging material against a wall or obstruction; material may ricochet toward you.
15. Do not use the machine on gravel surfaces.
16. If the machine strikes a foreign object, follow these steps:
  - Release the trigger and the safety interlock switch.
  - Remove the battery from the machine.
  - Inspect for damage.
  - Repair any damage before starting and operating the machine.
17. Shut off the machine and remove the battery before unclogging the machine and always use a stick or a cleanout tool to remove the clog.
18. Under abusive conditions, the battery pack may eject liquid; avoid contact. If you accidentally come into contact with the liquid, flush with water. If the liquid contacts your eyes, seek medical help. Liquid ejected from the battery pack may cause irritation or burns.
19. Do not expose a battery pack or tool to fire or excessive temperature. Exposure to fire or temperature above 130°C (265°F) may cause explosion.
20. CAUTION—A mistreated battery pack may present a risk of fire, explosion, or chemical burn.
  - Do not disassemble the battery pack.
  - Replace the battery pack with a genuine Flex-Force battery pack only; using another type of battery pack may cause a fire or risk of injury.
  - Keep battery packs out of the reach of children and in the original packaging until you are ready to use them.

#### IV. Maintenance and Storage

1. Remove the battery pack from the machine, and wait for all movement to stop before adjusting, servicing, cleaning, or storing the machine.
2. Do not attempt to service or repair the machine, battery pack, or battery charger except as indicated in the instructions. Have an Authorized Service Dealer perform service using identical replacement parts to ensure that the product is safely maintained.
3. Wear gloves and eye protection when servicing the machine.
4. When servicing the rotor, be aware that the rotor can still move even though the power source is off.
5. For best performance, use only genuine Toro replacement parts and accessories. Other replacement parts and accessories could be dangerous.
6. Maintain the machine—Keep handles dry, clean, and free from oil and grease. Keep guards in place and in working order. Use identical replacement parts only.
7. Check all fasteners at frequent intervals for proper tightness to ensure that the machine is in safe working condition.
8. Check the machine for damaged parts. Check for misaligned and binding moving parts, broken parts, mounting, and any other condition that may affect its operation. Unless indicated in the instructions, have an Authorized Service Dealer repair or replace a damaged guard or part.
9. When the battery pack is not in use, keep it away from metal objects such as paper clips, coins, keys, nails, and screws that can make a connection from 1 terminal to another. Shorting the battery terminals may cause burns or a fire.
10. When you are not using the machine, store it indoors in a dry, secure place out of the reach of children.
11. When storing the machine for more than 30 days, refer to [Storage \(page 15\)](#) for important information.

## SAVE THESE INSTRUCTIONS

# Safety and Instructional Decals



Safety decals and instructions are easily visible to the operator and are located near any area of potential danger. Replace any decal that is damaged or missing.

Model 39909

**WARNING** To reduce risk of injury to persons, remove battery pack when not in use. Store indoors. For use with approved TORO 60V accessories, batteries & charger models.

**AVERTISSEMENT** Pour réduire les risques de blessures corporelles, retirez la batterie quand vous ne l'utilisez pas. Remiser à l'intérieur. À utiliser avec les accessoires, batteries et modèles de chargeurs TORO 60V approuvés.

**ADVERTENCIA** Para reducir el riesgo de lesiones a personas, retire la batería cuando no esté en uso. Únicamente para uso doméstico. Para su uso con modelos aprobados de baterías y cargadores TORO de 60 V.

**CAUTION** Use for snow removal only. **ATTENTION** Utiliser uniquement pour le déneigement.

**PRECAUCIÓN** Sólo para quitar nieve.

**WARNING:** Cancer and Reproductive Harm - www.P65Warnings.ca.gov. For more information, please visit www.ttcocaprop65.com

**AVERTISSEMENT:** Cancer et Troubles de l'appareil reproducteur - www.P65Warnings.ca.gov. Pour plus d'informations, veuillez visiter www.toro.com/CAProp65

**ADVERTENCIA:** Cáncer y Daño Reproductivo - www.P65Warnings.ca.gov. Para obtener más información, visite www.toro.com/CAProp65

**TORO**

THE TORO COMPANY  
8111 Lyndale Avenue South  
Bloomington, MN 55420-1196 USA

Country of Origin: VIETNAM  
PATENT: www.ttcopats.com

Conforms to / Conforme à la norme / Cumple la norma  
UL 60335-1, UL 1090, UL 2595

Certified to / Certifié / Homologada según  
CSA-C22.2 #147-15

60V MAX\* DC

\*60VDC MAXIMUM / 54VDC NOMINAL  
\*60 VDC MAXIMUM / 54 VDC NOMINALE  
\*60 VDC MÁXIMA / 54 VDC NOMINAL

950W RATED / 950 W NOMINALE / 950 W NOMINAL

Date Code: **39909**  
Code de date :  
Código de fecha :

Model: **39909**  
Modèle / Modelo :

Serial Number: **31800000 MM YY**  
Numéro de série :  
Número de Serie :

161-6044

g503847

1. Double insulated

Model 39909T

**WARNING** To reduce risk of injury to persons, remove battery pack when not in use. Store indoors. For use with approved TORO 60V accessories, batteries & charger models.

**AVERTISSEMENT** Pour réduire les risques de blessures corporelles, retirez la batterie quand vous ne l'utilisez pas. Remiser à l'intérieur. À utiliser avec les accessoires, batteries et modèles de chargeurs TORO 60V approuvés.

**ADVERTENCIA** Para reducir el riesgo de lesiones a personas, retire la batería cuando no esté en uso. Únicamente para uso doméstico. Para su uso con modelos aprobados de baterías y cargadores TORO de 60 V.

**CAUTION** Use for snow removal only. **ATTENTION** Utiliser uniquement pour le déneigement.

**PRECAUCIÓN** Sólo para quitar nieve.

**WARNING:** Cancer and Reproductive Harm - www.P65Warnings.ca.gov. For more information, please visit www.ttcocaprop65.com

**AVERTISSEMENT:** Cancer et Troubles de l'appareil reproducteur - www.P65Warnings.ca.gov. Pour plus d'informations, veuillez visiter www.toro.com/CAProp65

**ADVERTENCIA:** Cáncer y Daño Reproductivo - www.P65Warnings.ca.gov. Para obtener más información, visite www.toro.com/CAProp65

**TORO**

THE TORO COMPANY  
8111 Lyndale Avenue South  
Bloomington, MN 55420-1196 USA

Country of Origin: VIETNAM  
PATENT: www.ttcopats.com

Conforms to / Conforme à la norme / Cumple la norma  
UL 60335-1, UL 1090, UL 2595

Certified to / Certifié / Homologada según  
CSA-C22.2 #147-15

60V MAX\* DC

\*60VDC MAXIMUM / 54VDC NOMINAL  
\*60 VDC MAXIMUM / 54 VDC NOMINALE  
\*60 VDC MÁXIMA / 54 VDC NOMINAL

950W RATED / 950 W NOMINALE / 950 W NOMINAL

Date Code: **39909T**  
Code de date :  
Código de fecha :

Model: **39909T**  
Modèle / Modelo :

Serial Number: **31800000 MM YY**  
Numéro de série :  
Número de Serie :

161-6045

g503848

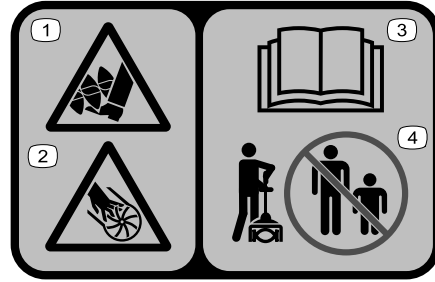

decal140-8464

140-8464

1. Cutting/dismemberment hazard of foot; auger
2. Cutting/dismemberment hazard of hand; impeller
3. Read the *Operator's Manual*.
4. Keep bystanders away.



decal94-8072

94-8072



137-9462

decal137-9462



137-9454

decal137-9454

1. Read the *Operator's Manual*.
2. Call2Recycle® battery recycling program
3. Keep away from open fire or flames.
4. Do not expose to rain.

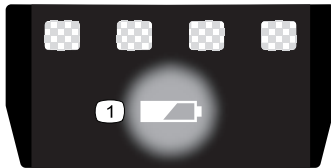

137-9461

decal137-9461

1. Battery charge status

# Setup

**Important:** The battery pack is not fully charged when it is purchased. Before using the machine for the first time, refer to [Charging the Battery Pack \(page 13\)](#).

## Mounting the Battery Charger (Optional)

If desired, mount the battery charger securely on a wall using the wall-mount key holes on the back of the charger.

Mount it indoors (such as a garage or other dry place), near a power outlet, and out of the reach of children.

Refer to [Figure 5](#) for assistance in mounting the charger.

Slide the charger over the appropriately positioned hardware to secure the charger in place (hardware not included).

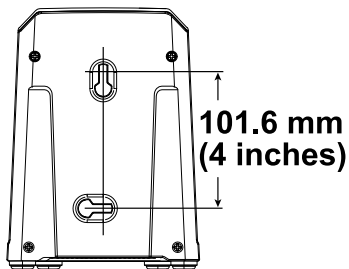

**Figure 5**

g290534



# Unfolding the Handle

1. Unfold the handle (A of [Figure 6](#)).
2. Align the locking button on the lower shaft with the slotted hole on the upper shaft and slide the 2 shafts together (B and C of [Figure 6](#)).  
**Note:** The locking button clicks into the slotted hole when the shafts are secured (D of [Figure 6](#)).
3. Using the provided Allen wrench, tighten the screw on the shaft connector until it is secure (E of [Figure 6](#)).

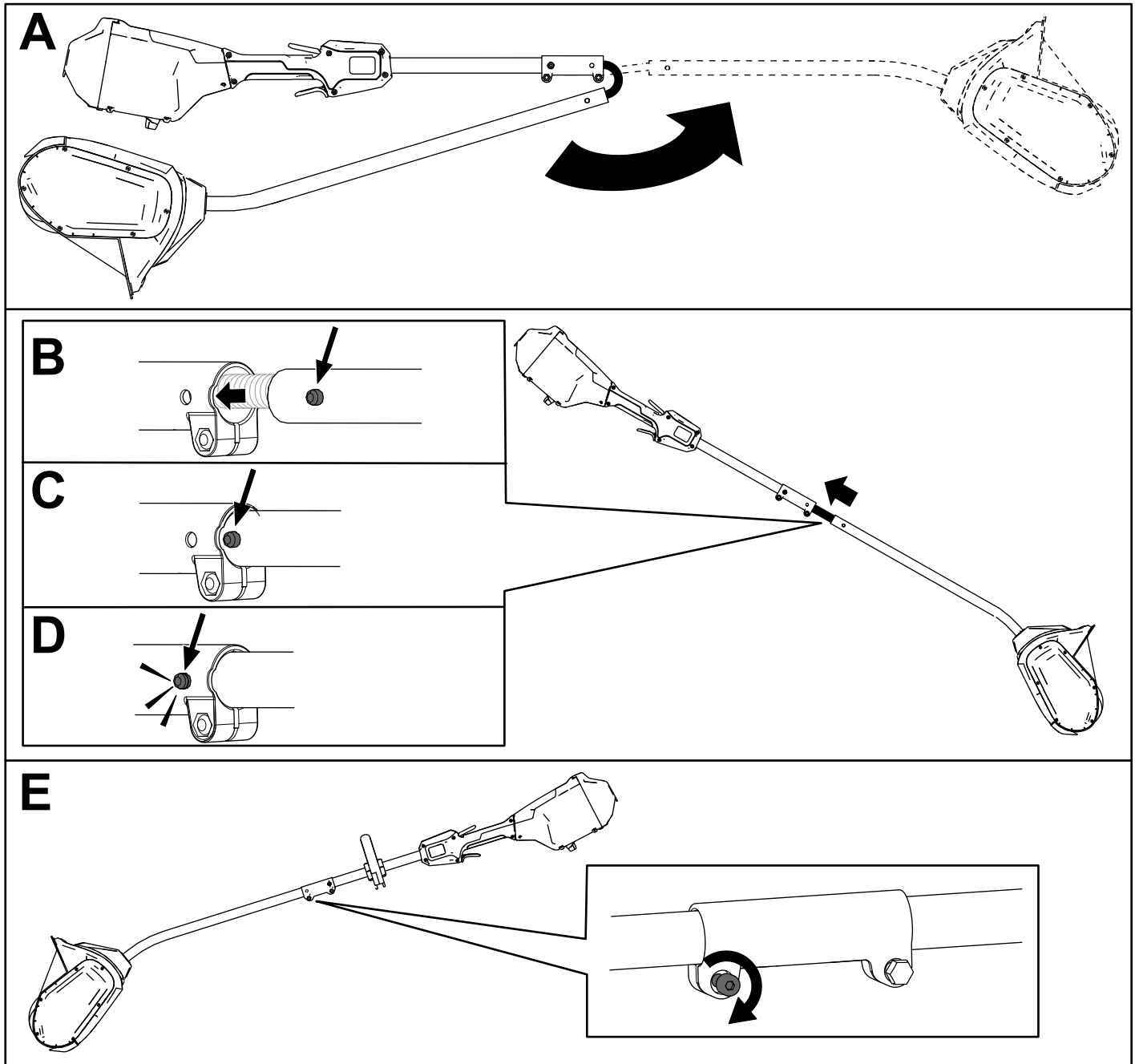

Figure 6

g316332

# Installing the Auxiliary Handle

1. Separate the auxiliary handle from the handle plate by removing the 4 socket head screws using the provided Allen wrench (A of [Figure 7](#)).
2. Line up the auxiliary handle with auxiliary handle plate on the shaft (B of [Figure 7](#)).
3. Secure the auxiliary handle to the handle plate with the 4 socket head screws previously removed (C of [Figure 7](#)).

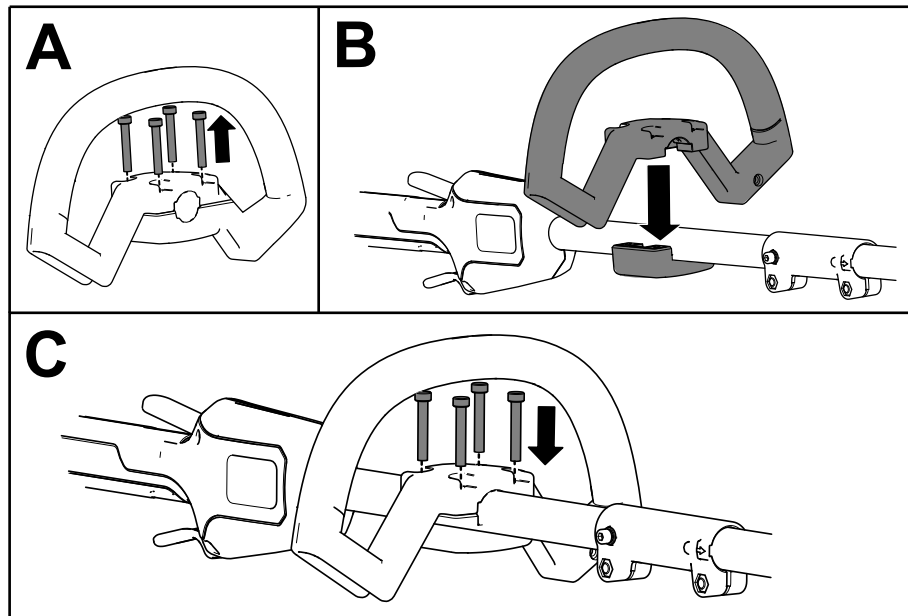
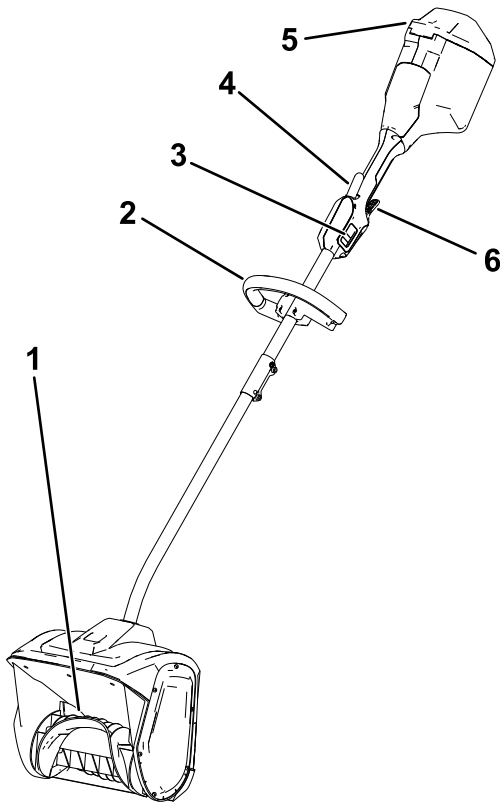

Figure 7

g382609

# Product Overview



**Figure 8**

- |                   |                    |
|-------------------|--------------------|
| 1. Rotor          | 4. Lockout trigger |
| 2. Handle         | 5. Battery lid     |
| 3. 2-speed switch | 6. Run trigger     |

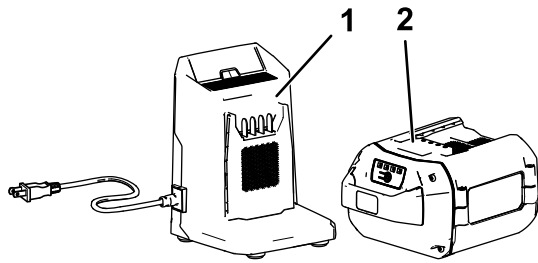

**Figure 9**

- |  |   |
|--|---|
| 1. Battery charger Model 88625 (included with Model 39909) | 2. Battery pack Model 88625 (included with Model 39909) |
|--|---|

# Specifications

## Battery Pack

<b>Model</b>	<b>88625</b>
Battery pack capacity	2.5 Ah 135 Wh
Battery manufacturer rating = 60V maximum and 54V nominal. Actual voltage varies with load.	

## Battery Charger

<b>Model</b>	<b>88602</b>
<b>Type</b>	60V MAX Lithium-Ion Battery Charger
<b>Input</b>	120V AC ~2.0A, 60Hz
<b>Output</b>	60V DC  2.0A MAX

## Appropriate Temperature Ranges

Charge/store the battery pack at	5°C (41°F) to 40°C (104°F)*
Use the battery pack at	-30°C (-22°F) to 49°C (120°F)*
Use the machine at	-30°C (-22°F) to 49°C (120°F)*

\*Charging time will increase if you do not charge the battery within this range.

Store the machine, battery pack, and battery charger in an enclosed clean, dry area.

## Attachments/Accessories

A selection of Toro approved attachments and accessories is available for use with the machine to enhance and expand its capabilities. Contact your Authorized Service Dealer or authorized Toro distributor or go to [www.Toro.com](http://www.Toro.com) for a list of all approved attachments and accessories.

To ensure optimum performance and continued safety certification of the machine, use only genuine Toro replacement parts and accessories. Replacement parts and accessories made by other manufacturers could be dangerous.

# Operation

## Starting the Machine

**Important:** Use the battery pack only in temperatures that are within the appropriate range; refer to [Specifications \(page 11\)](#).

1. Ensure that the vents on the back of the machine are clear of any snow or ice ([Figure 10](#)).

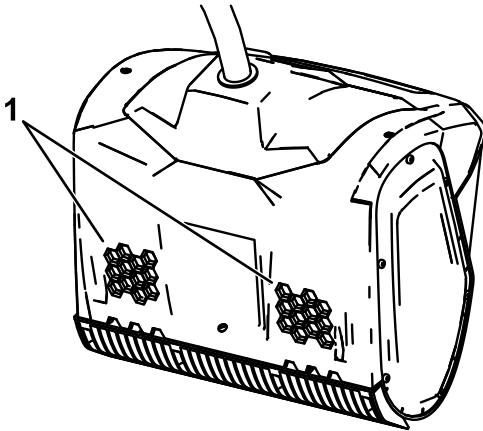

Figure 10

g316735

1. Air vents

2. Open the battery lid ([Figure 11](#)).
3. Align the cavity in the battery pack with the tongue in the battery compartment ([Figure 11](#)).
4. Push the battery pack into the battery compartment until the battery locks into the latch ([Figure 11](#)).

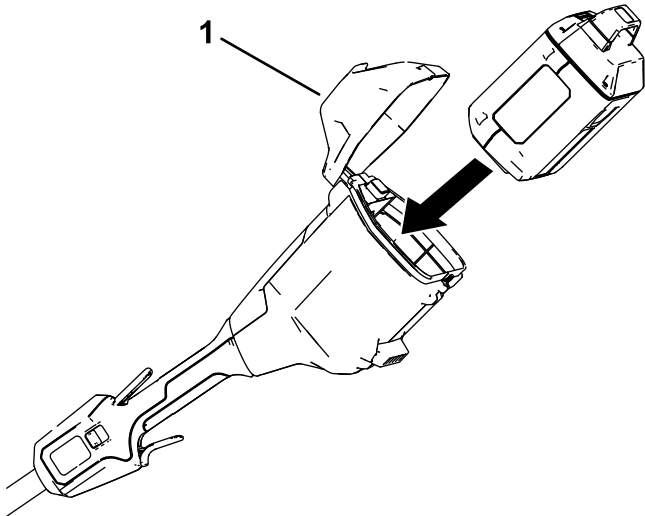

Figure 11

g316333

1. Battery lid

5. Close the battery lid.

**Note:** If the battery-compartment lid does not close completely, the battery is not fully installed.

6. To start the machine, squeeze the lockout trigger, then squeeze the run trigger ([Figure 12](#)).

**Note:** Slide the 2-speed switch to change the speed of the rotor.

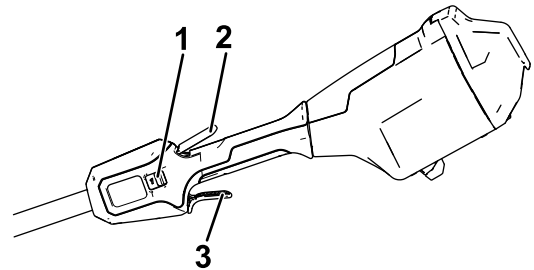

Figure 12

g316334

1. 2-speed switch
2. Lockout trigger
3. Run trigger

## Shutting Off the Machine

To shut off the machine, release the run trigger.

Whenever you are not using the machine or are transporting the machine to or from the work area, remove the battery pack; refer to [Removing the Battery Pack \(page 12\)](#).

## Removing the Battery Pack

Open the battery lid, press the battery latch to release the battery pack, and slide the battery pack out of the machine ([Figure 13](#)).

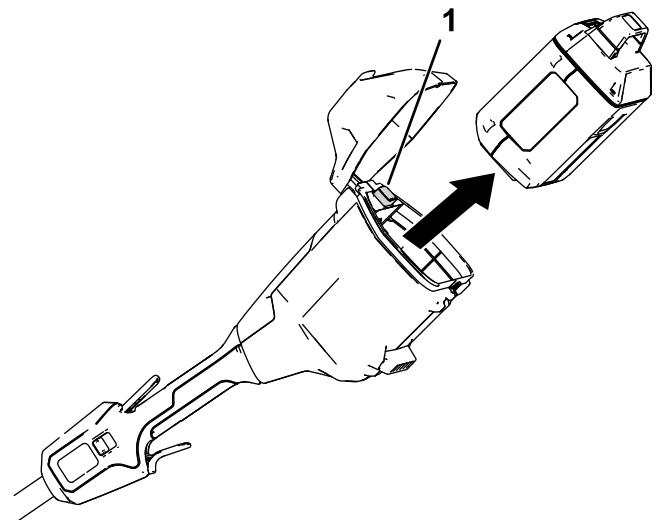

Figure 13

g316335

1. Battery latch

# Charging the Battery Pack

**Important:** The battery pack is not fully charged when you purchase it. Before using the tool for the first time, place the battery pack in the charger and charge it until the LED display indicates the battery pack is fully charged. Read all safety precautions.

**Important:** Charge the battery pack only in temperatures that are within the appropriate range; refer to [Specifications \(page 11\)](#).

**Note:** At any time, press the battery-charge-indicator button on the battery pack to display the current charge (LED indicators).

1. Ensure that the vents and charging terminals on the battery pack and charger are clear of any dust and debris.

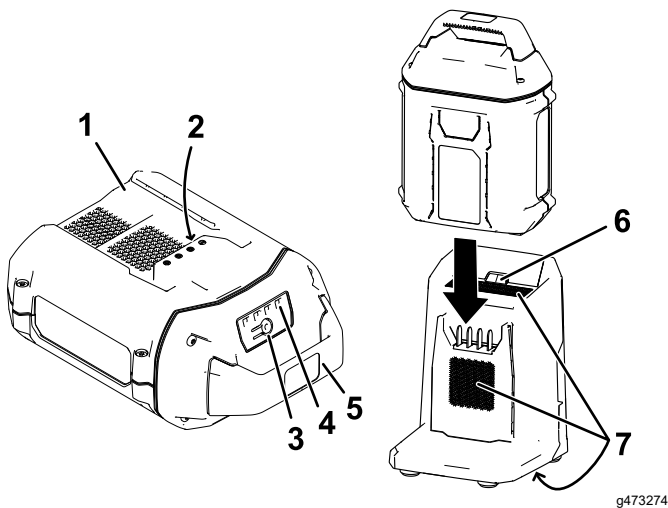

Figure 14

- |                                    |                                |
|------------------------------------|--------------------------------|
| 1. Battery-pack cavity             | 5. Handle                      |
| 2. Battery-pack terminals          | 6. Charger LED indicator light |
| 3. Battery-charge-indicator button | 7. Charger venting areas       |
| 4. LED indicators (current charge) |                                |
2. Line up the cavity in the battery pack ([Figure 14](#)) with the tongue on the charger.
  3. Slide the battery pack into the charger until it is fully seated ([Figure 14](#)).
  4. To remove the battery pack, slide the battery backward out of the charger.

5. Refer to the following table to interpret the LED indicator light on the battery charger.

Indicator light	Indicates
Off	No battery pack inserted
Green blinking	Battery pack is charging
Green	Battery pack is charged
Red	Battery pack and/or battery charger is over or under the appropriate temperature range
Red blinking	Battery pack charging fault*

\*Refer to [Troubleshooting \(page 16\)](#) for more information.

**Important:** The battery pack can be left on the charger for short periods between uses.

If the battery pack will not be used for longer periods, remove the battery pack from the charger; refer to [Storage \(page 15\)](#).

## Operating Tips

- Start the machine and tilt it forward until the scraper blade contacts the ground. Push the machine forward at a comfortable rate of speed, yet slow enough to clear the path completely. The width and depth of the snow determines your forward speed.
- For the most efficient snow removal, throw the snow downwind, and slightly overlap each swath.
- The machine can remove snow up to 15 cm (6 inches) deep in one pass. When clearing deeper drifts, hold the machine by the upper and lower handles and use a swinging or sweeping motion. Remove a maximum of 15 cm (6 inches) with each pass and repeat as many times as required.

# Maintenance

## **▲ DANGER**

Contact with the rotor can cause serious personal injury.

- Remove the battery pack before adjusting or maintaining the machine.
- Always wear gloves when adjusting or maintaining the machine.

## Replacing the Scraper Blade

**Service Interval:** Every 20 hours

Remove the 4 screws securing the scraper blade and replace the scraper blade as necessary.

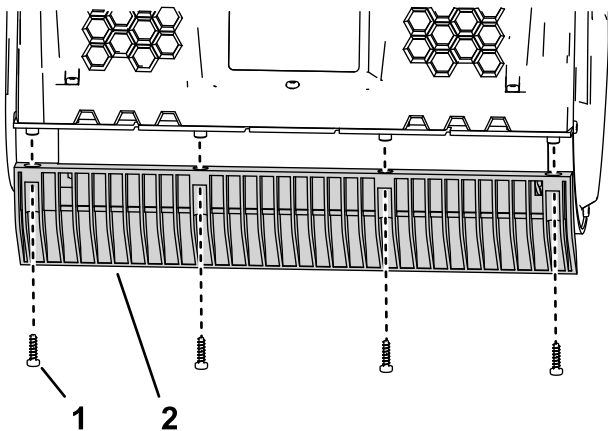

Figure 15

g316736

1. Screw

2. Scraper blade

# Preparing the Battery Pack for Recycling

**Important:** Upon removal, cover the terminals of the battery pack with heavy-duty adhesive tape. Do not attempt to destroy or disassemble the battery pack or remove any of its components.



Lithium-ion battery packs labeled with the Call2Recycle seal can be recycled at any participating retailer or battery recycling facility in the Call2Recycle program (US and Canada only). To locate a participating retailer or facility closest to you, please call 1-800-822-8837 or visit [www.call2recycle.org](http://www.call2recycle.org). If you cannot locate a participating retailer or facility nearby, or if your rechargeable battery is not labeled with the Call2Recycle seal, please contact your local municipality for more information on how to responsibly recycle the battery. If you are located outside of the US and Canada, please contact your authorized Toro distributor.

## Service

Should the machine need service, take it to your Authorized Service Dealer.

# Storage

**Important:** Store the machine, battery pack, and charger only in temperatures that are within the appropriate range; refer to [Specifications \(page 11\)](#).

**Important:** If you are storing the machine for a year or longer, remove the battery pack from the machine and charge the battery pack until 1 or 2 LED indicators turn green on the battery. Do not store a fully charged or fully depleted battery. When you are ready to use the machine again, charge the battery pack until the left indicator light turns green on the charger or all 4 LED indicators turn green on the battery.

- Disconnect the machine from the power supply (i.e., remove the battery pack) and check for damage after use.
- Clean all foreign material from the machine.
- Do not store the machine or charger with the battery pack installed.
- When not in use, store the machine, battery pack, and battery charger out of the reach of children.
- Keep the machine, battery pack, and battery charger away from corrosive agents such as garden chemicals and de-icing salts.
- To reduce the risk of serious personal injury, do not store the battery pack outside or in vehicles.
- Store the machine, battery pack, and battery charger in an enclosed clean, dry area.

# Troubleshooting

Perform only the steps described in these instructions. All further inspection, maintenance, and repair work must be performed by an authorized service center or a similarly qualified specialist if you cannot solve the problem yourself.

Always remove the battery from the tool when troubleshooting, inspecting, maintaining, or cleaning the tool.

Problem	Possible Cause	Corrective Action
The machine does not run or does not run continuously.	<ol style="list-style-type: none"> <li>1. The battery is not fully installed in the machine.</li> <li>2. The battery pack is not charged.</li> <li>3. The battery pack is damaged.</li> <li>4. There is another electrical problem with the machine.</li> </ol>	<ol style="list-style-type: none"> <li>1. Remove and then replace the battery into the machine, making sure that it is fully installed and latched.</li> <li>2. Remove the battery pack from the machine and charge it.</li> <li>3. Replace the battery pack.</li> <li>4. Contact an Authorized Service Dealer.</li> </ol>
The machine does not reach full power.	<ol style="list-style-type: none"> <li>1. The battery pack charge capacity is too low.</li> <li>2. The air vents are blocked.</li> </ol>	<ol style="list-style-type: none"> <li>1. Remove the battery pack from the machine and fully charge the battery pack.</li> <li>2. Clean the air vents.</li> </ol>
The machine is producing excessive vibration or noise.	<ol style="list-style-type: none"> <li>1. The rotor is damaged.</li> </ol>	<ol style="list-style-type: none"> <li>1. Contact an Authorized Service Dealer.</li> </ol>
The battery pack loses charge quickly.	<ol style="list-style-type: none"> <li>1. The battery pack is over or under the appropriate temperature range.</li> <li>2. The machine is overloaded</li> </ol>	<ol style="list-style-type: none"> <li>1. Move the battery pack to a place where it is dry and the temperature is between 5°C (41°F) and 40°C (104°F).</li> <li>2. Work at a slower pace.</li> </ol>
The battery charger is not working.	<ol style="list-style-type: none"> <li>1. The battery charger is over or under the appropriate temperature range.</li> <li>2. The outlet that the battery charger is plugged into does not have power.</li> </ol>	<ol style="list-style-type: none"> <li>1. Unplug the battery charger and move it to a place where it is dry and the temperature is between 5°C (41°F) and 40°C (104°F).</li> <li>2. Contact your licensed electrician to repair the outlet.</li> </ol>
The LED indicator light on the battery charger is red.	<ol style="list-style-type: none"> <li>1. The battery charger and/or battery pack is over or under the appropriate temperature range.</li> </ol>	<ol style="list-style-type: none"> <li>1. Unplug the battery charger and battery pack to a place where it is dry and the temperature is between 5°C (41°F) and 40°C (104°F).</li> </ol>
The LED indicator light on the battery charger is blinking red.	<ol style="list-style-type: none"> <li>1. There is an error in the communication between the battery pack and the charger.</li> <li>2. The battery pack is weak.</li> </ol>	<ol style="list-style-type: none"> <li>1. Remove the battery pack from the battery charger, unplug the battery charger from the outlet, and wait 10 seconds. Plug the battery charger into the outlet again and place the battery pack on the battery charger. If the LED indicator light on the battery charger is still blinking red, repeat this procedure again. If the LED indicator light on the battery charger is still blinking red after 2 attempts, properly dispose of the battery pack at a battery recycling facility.</li> <li>2. Contact your authorized service dealer if the battery is in warranty, or properly dispose of the battery pack at a battery recycling facility.</li> </ol>



# Notes:

# Notes:

# California Proposition 65 Warning Information

## What is this warning?

You may see a product for sale that has a warning label like the following:



**WARNING: Cancer and Reproductive Harm—[www.p65Warnings.ca.gov](http://www.p65Warnings.ca.gov).**

## What is Prop 65?

Prop 65 applies to any company operating in California, selling products in California, or manufacturing products that may be sold in or brought into California. It mandates that the Governor of California maintain and publish a list of chemicals known to cause cancer, birth defects, and/or other reproductive harm. The list, which is updated annually, includes hundreds of chemicals found in many everyday items. The purpose of Prop 65 is to inform the public about exposure to these chemicals.

Prop 65 does not ban the sale of products containing these chemicals but instead requires warnings on any product, product packaging, or literature with the product. Moreover, a Prop 65 warning does not mean that a product is in violation of any product safety standards or requirements. In fact, the California government has clarified that a Prop 65 warning "is not the same as a regulatory decision that a product is 'safe' or 'unsafe.'" Many of these chemicals have been used in everyday products for years without documented harm. For more information, go to <https://oag.ca.gov/prop65/faqs-view-all>.

A Prop 65 warning means that a company has either (1) evaluated the exposure and has concluded that it exceeds the "no significant risk level"; or (2) has chosen to provide a warning based on its understanding about the presence of a listed chemical without attempting to evaluate the exposure.

## Does this law apply everywhere?

Prop 65 warnings are required under California law only. These warnings are seen throughout California in a wide range of settings, including but not limited to restaurants, grocery stores, hotels, schools, and hospitals, and on a wide variety of products. Additionally, some online and mail order retailers provide Prop 65 warnings on their websites or in catalogs.

## How do the California warnings compare to federal limits?

Prop 65 standards are often more stringent than federal and international standards. There are various substances that require a Prop 65 warning at levels that are far lower than federal action limits. For example, the Prop 65 standard for warnings for lead is 0.5 µg/day, which is well below the federal and international standards.

## Why don't all similar products carry the warning?

- Products sold in California require Prop 65 labelling while similar products sold elsewhere do not.
- A company involved in a Prop 65 lawsuit reaching a settlement may be required to use Prop 65 warnings for its products, but other companies making similar products may have no such requirement.
- The enforcement of Prop 65 is inconsistent.
- Companies may elect not to provide warnings because they conclude that they are not required to do so under Prop 65; a lack of warnings for a product does not mean that the product is free of listed chemicals at similar levels.

## Why does Toro include this warning?

Toro has chosen to provide consumers with as much information as possible so that they can make informed decisions about the products they buy and use. Toro provides warnings in certain cases based on its knowledge of the presence of one or more listed chemicals without evaluating the level of exposure, as not all the listed chemicals provide exposure limit requirements. While the exposure from Toro products may be negligible or well within the "no significant risk" range, out of an abundance of caution, Toro has elected to provide the Prop 65 warnings. Moreover, if Toro does not provide these warnings, it could be sued by the State of California or by private parties seeking to enforce Prop 65 and subject to substantial penalties.



**Count on it.**