



Count on it.

Parts Catalog

323 Compact Tool Carrier

Model No. 22318—Serial No. 415200000 and Up



Ordering Replacement Parts

To order replacement parts, please supply the part number, the quantity, and the description of each part desired.

Understanding Reference Numbers

Each identified part in an illustration has a reference number. The reference number for a part also appears in the parts list, along with other information about the part.

This catalog uses two special reference number formats, one to indicate parts in a service assembly and another to indicate the quantity of a given part in an illustration.

Service Assembly Reference Numbers

Parts in service assemblies have reference numbers in the form a:b. The a represents the reference number of the entire service assembly and the b represents a sequential number unique to each part within the service assembly.

For example, a wheel assembly might be identified by reference number 6, the tire by 6:1, the valve by 6:2, and the wheel by 6:3. When you order the assembly identified by reference number 6, you receive all parts identified by reference numbers 6:1, 6:2, and 6:3. However, you may also order any part individually. Reference numbers of this type appear in illustration and in parts lists.

Reference Numbers Indicating Quantity

In an illustration, if a reference number indicates more than one part, the reference number has the form nX y. The n represents the quantity of the part, the X is the multiplication symbol, and the y represents the reference number.

For example, in an illustration, the reference number 2X 37 means that two of the parts identified by reference number 37 are indicated.

Contents

Frame Assembly	4
Hood and Screen Assembly	6
Thigh Support Assembly	8
Wheel and Tire Assembly	10
Hydraulic Motor Assembly No. 99-3052	12
Engine and Hydraulic Pump Assembly	14
Tandem Hydraulic Pump Assembly No. 108-4710	16
Fuel Tank and Air Filter Assembly	18
Air Cleaner Assembly No. 93-2190	20
Carbon Canister Assembly	22
Loader and Quick Attach Assembly	24
Electrical Component Assembly	26
Hydraulic Tank and Filter Assembly	28
Auxiliary Control Lever Assembly	30
Auxiliary Valve and Selector Valve Assembly	32
Auxiliary Hydraulic Valve Assembly No. 99-3077	34
Hydraulic Selector Valve Assembly No. 99-3072	36
Four Spool Valve and Lever Assembly	38
Four Spool Hydraulic Valve Assembly No. 105-8377	40
Hydraulic Motor Assembly	42
Counterbalance Valve Assembly No. 99-3040	44
Hydraulic Cylinder Assembly	46
Hydraulic Cylinder Assembly No. 139-7706	48
Attachments and Accessories	50

Frame Assembly (continued)

<i>Ref.</i>	<i>Part Number</i>	<i>Qty.</i>	<i>Description</i>	<i>Ref.</i>	<i>Part Number</i>	<i>Qty.</i>	<i>Description</i>
1	108-9710	1	Frame ASM	10:3	112-4948	1	Tread
1:2	98-4871	2	Bushing-Tension	11	99-8638	1	Pin
1:3	98-9947	2	Tread-Foot	12	99-9978	1	Pin-Lynch
1:4	144-2025	1	Decal-Control Panel	13	105-8429	2	Decal
1:6	98-8219	1	Decal-Throttle	16	94-2551	1	Decal-Choke
1:7	93-6686	1	Decal-Oil, HYD	17	133-8062	1	Decal-Spark Arrestor
2	106-8178-01	2	Cover-Hose	18	93-9084	4	Decal-Point, Lift
3	32144-70	8	Screw-HWHTF	20	98-4387	1	Decal-Protection, Ear
4	108-9716	1	Decal-Selector, Speed	21	139-7704	1	Weight-Front, Counter
5	98-4845	2	Grip-Cushion	22	144-7148-03	1	Weight-Counter [black]
7	94-1402	2	Plug-Hole	23	HDW01729	4	Washer, 1/2, F436 Hard, F/W, YZN
9	62-5550	1	Decal	24	325-14	4	Screw-HH
10	112-4947	1	Counterweight ASM				
10:2	98-9947	1	Tread-Foot				

Hood and Screen Assembly

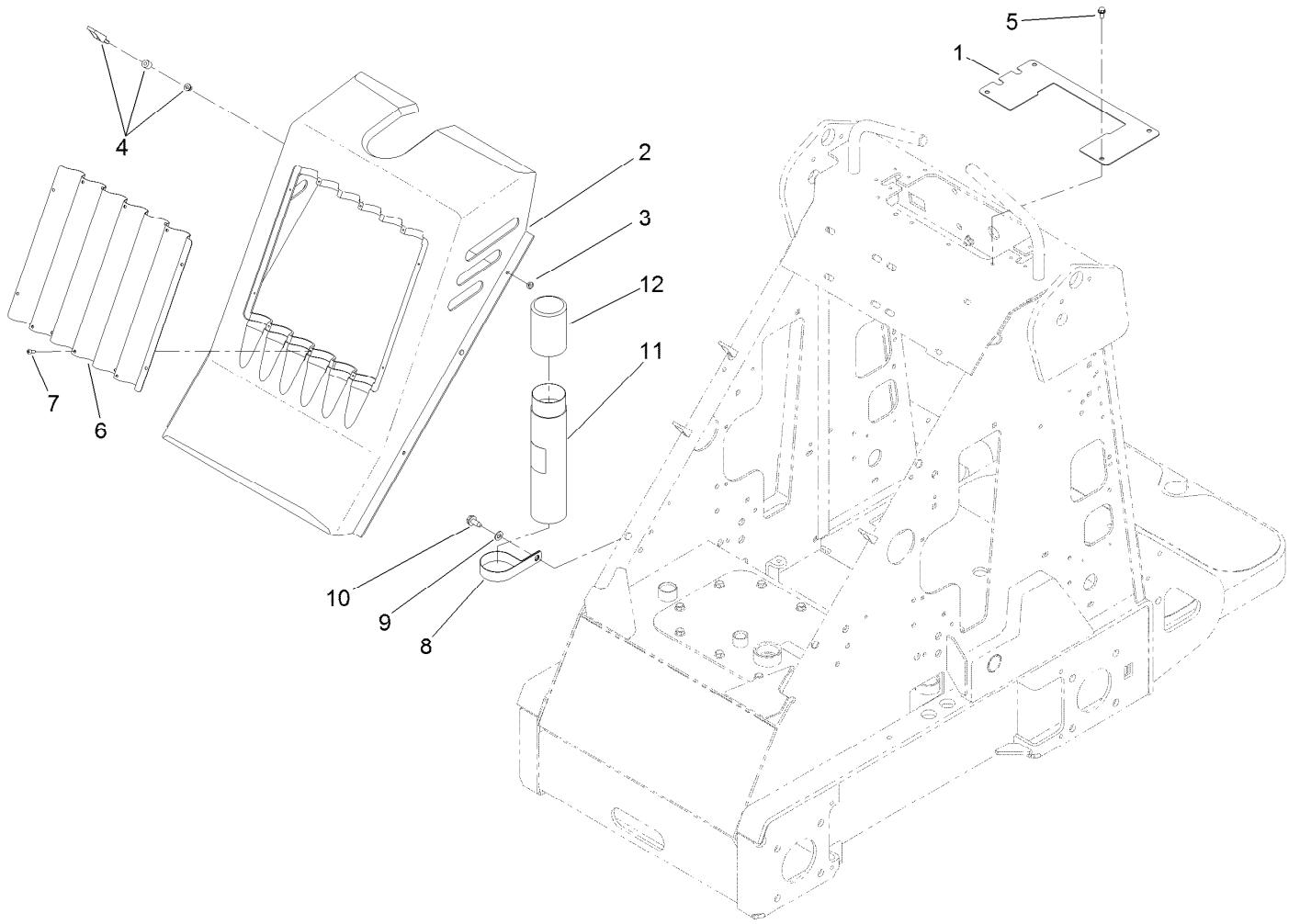

Hood and Screen Assembly (continued)

<i>Ref.</i>	<i>Part Number</i>	<i>Qty.</i>	<i>Description</i>	<i>Ref.</i>	<i>Part Number</i>	<i>Qty.</i>	<i>Description</i>
1	108-9731-03	1	Plate-Cover	7	32144-111	10	Screw-PPH
2	99-3164	1	Cover-Hood	8	2412-133	1	Clamp-R
3	99-3058	4	Washer	9	3256-23	1	Washer-Plain
4	74-5950	4	Latch-Swell	10	32144-70	1	Screw-HWHTF
5	32144-4	4	Screw-HWH	11	104-7050	1	Tube-Manual
6	99-3147-03	1	Grille-Screen	12	104-7048	1	Cap-Housing

Thigh Support Assembly

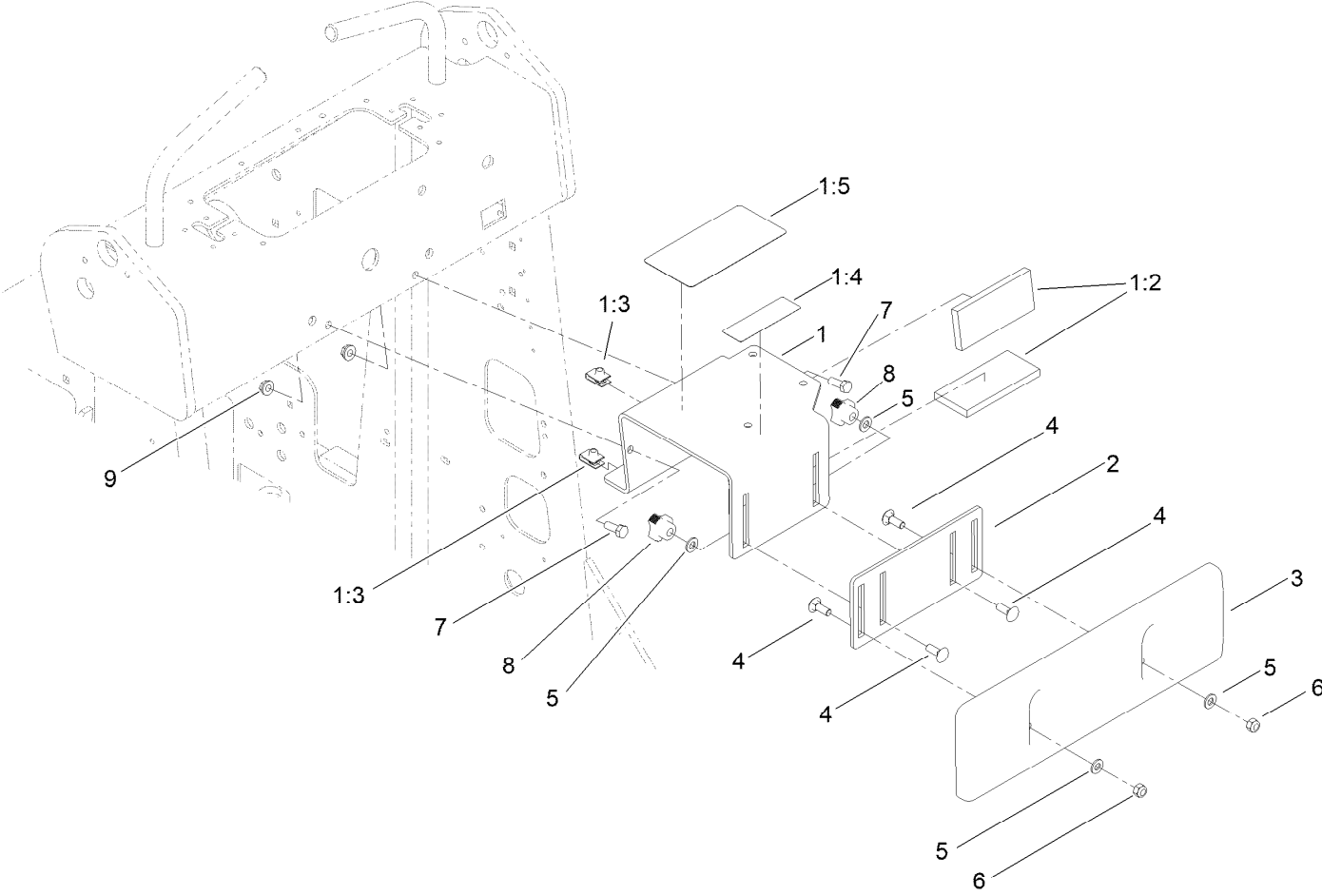

Thigh Support Assembly (continued)

<i>Ref.</i>	<i>Part Number</i>	<i>Qty.</i>	<i>Description</i>	<i>Ref.</i>	<i>Part Number</i>	<i>Qty.</i>	<i>Description</i>
1	117-1813	1	Thigh Support Bracket ASM	4	3230-16	4	Screw-CARR
1:2	117-1798	2	Pad-Foam	5	3256-70	4	Washer-Flat
1:3	115-7721	2	Nut-Clip, U	6	3296-72	2	Nut-Lock, NI
1:4	104-6108	1	Decal-Manual	7	322-4	2	Screw-HH
1:5	139-8815	1	Decal-Service Tx323	8	104-6156	2	Knob-Adjustment
2	105-0337-03	1	Plate-Adjusting	9	32128-20	2	Nut-HF
3	105-0333	1	Support-Thigh				

Wheel and Tire Assembly

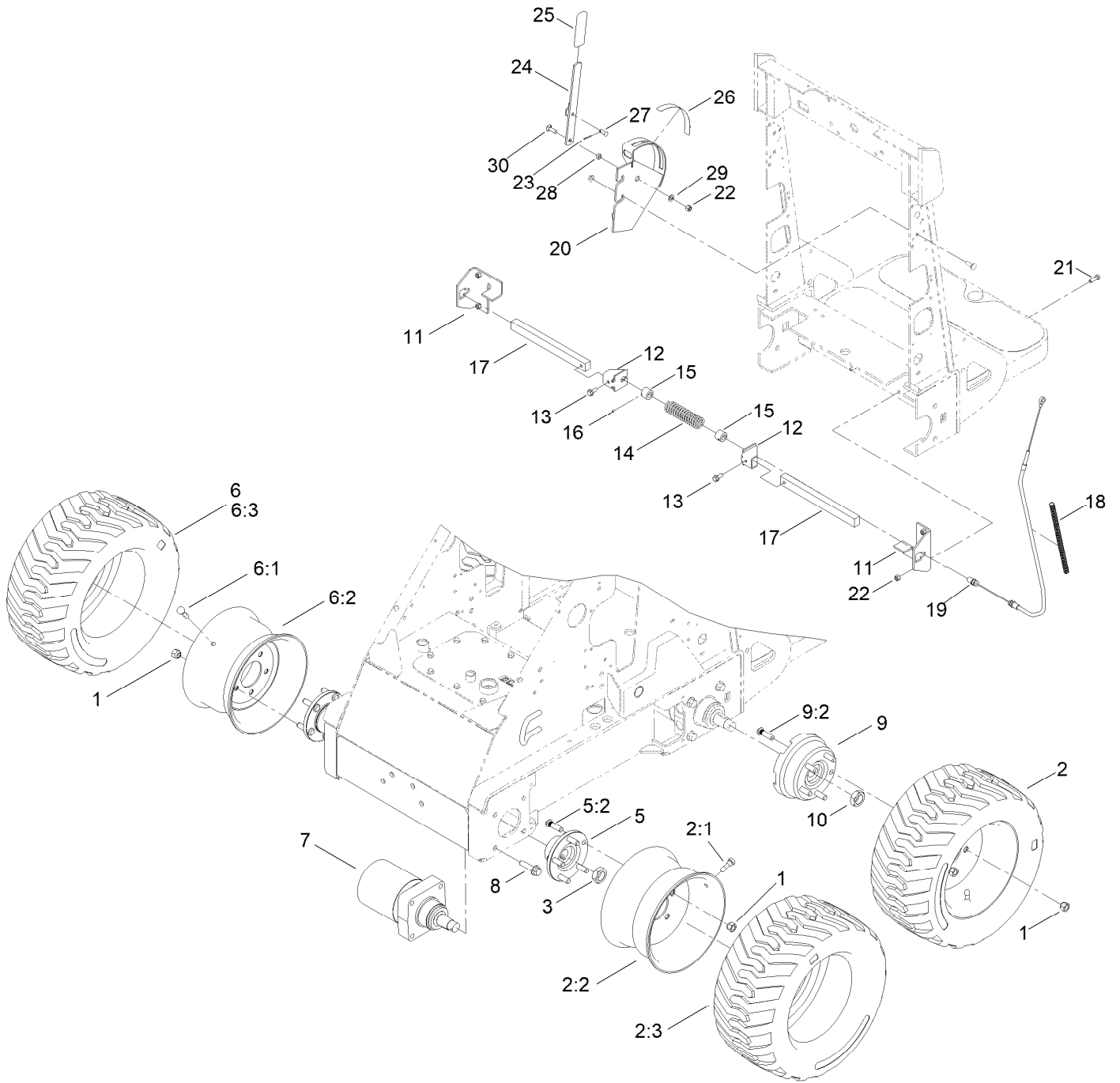

Wheel and Tire Assembly (continued)

<i>Ref.</i>	<i>Part Number</i>	<i>Qty.</i>	<i>Description</i>	<i>Ref.</i>	<i>Part Number</i>	<i>Qty.</i>	<i>Description</i>
1	242-50	20	Nut-Lug	13	100-1668	2	Screw-HHF
2	144-2575	2	Tire And Wheel ASM, LH	14	100-1678-03	1	Spring
2:1	232-27	1	Stem-Valve	15	100-6274	2	Tube-Guide
2:2	144-2572	1	Wheel-10X6.00, 5 Bolt	16	3245-20	2	Screw-Set
2:3	144-2573	1	Tire-18X8.50-10	17	100-1674-03	2	Bar-Brake
3	106-8159	4	Nut-Hex Jam Lck	18	100-4697	1	Tube-Convolutd
5	99-3064	2	Hub ASM	19	100-1679	1	Cable
5:2	10-6830	5	Stud-Type, Drive	20	105-8414-03	1	Plate-Brake
6	144-2574	2	Tire And Wheel ASM, RH	21	322-5	4	Screw-HH
6:1	232-27	1	Stem-Valve	22	3296-29	5	Nut-Lock, NI
6:2	144-2572	1	Wheel-10X6.00, 5 Bolt	23	3272-6	1	Pin-Cotter
6:3	144-2573	1	Tire-18X8.50-10	24	100-1684-03	1	Lever-Brake
7	99-3052	4	HYD Motor ASM	25	62-9130	1	Grip-Handle
8	3234-27	16	Screw-HHF	26	100-1692	1	Decal-Brake
9	105-4056	2	Wheel Hub ASM	27	283-62	1	Pin-Clevis
9:2	10-6830	5	Stud-Type, Drive	28	100-1683	1	Hub-Lever
10	106-8159	2	Nut-Hex Jam Lck	29	3256-23	1	Washer-Plain
11	100-1676-03	2	Bracket-Brake	30	3230-22	1	Screw-CARR
12	100-1677-03	2	Bracket-Cable				

Hydraulic Motor Assembly No. 99-3052

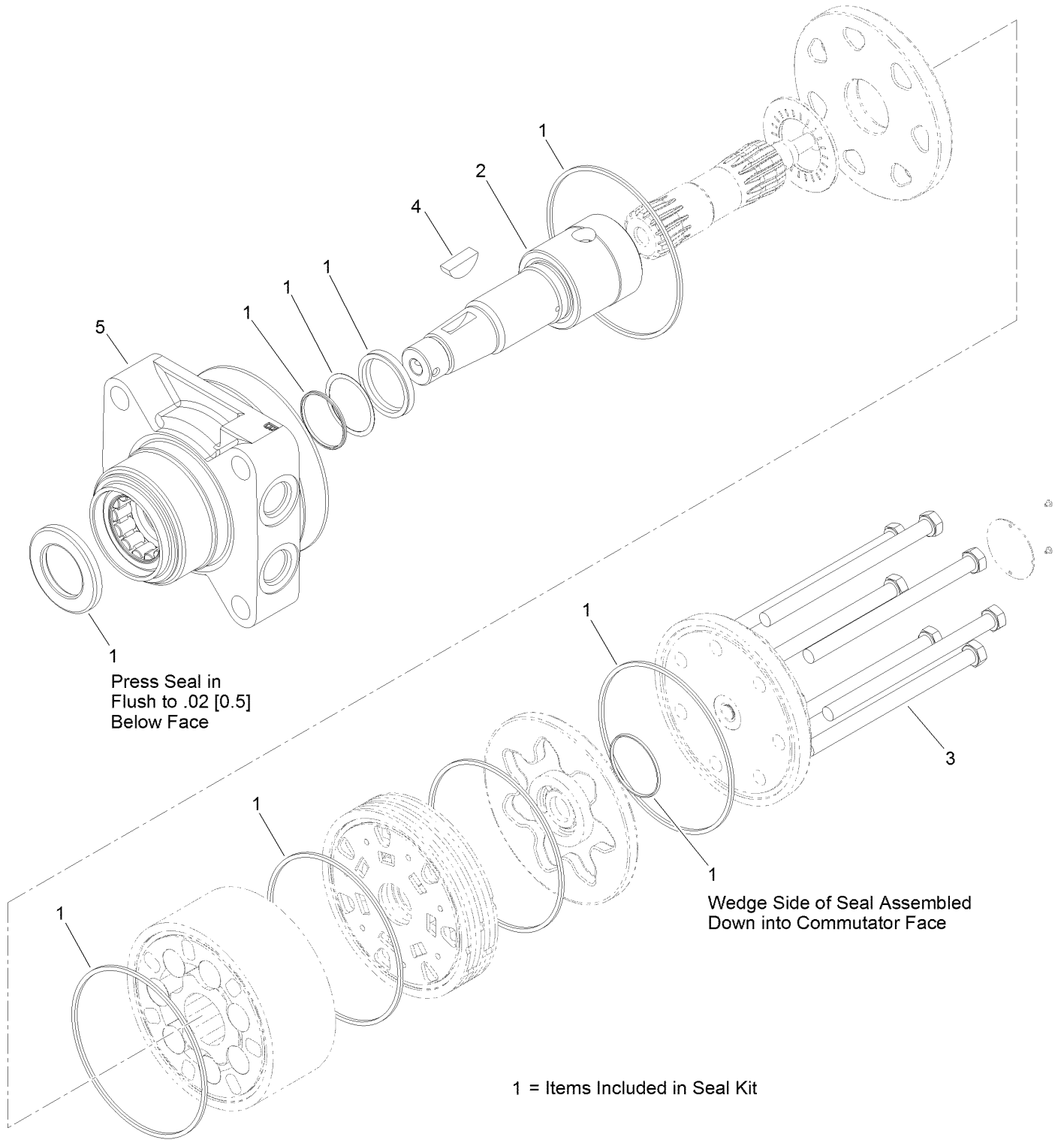

Hydraulic Motor Assembly No. 99-3052 (continued)

<i>Ref.</i>	<i>Part Number</i>	<i>Qty.</i>	<i>Description</i>
1	100-6131	1	Seal Kit
2	99-3090	1	Shaft-Coupling
3	99-3091	7	Screw-Cap, HH

<i>Ref.</i>	<i>Part Number</i>	<i>Qty.</i>	<i>Description</i>
4	3257-42	1	Key-Woodruff
5	120-5392	1	Motor Housing ASM

Engine and Hydraulic Pump Assembly

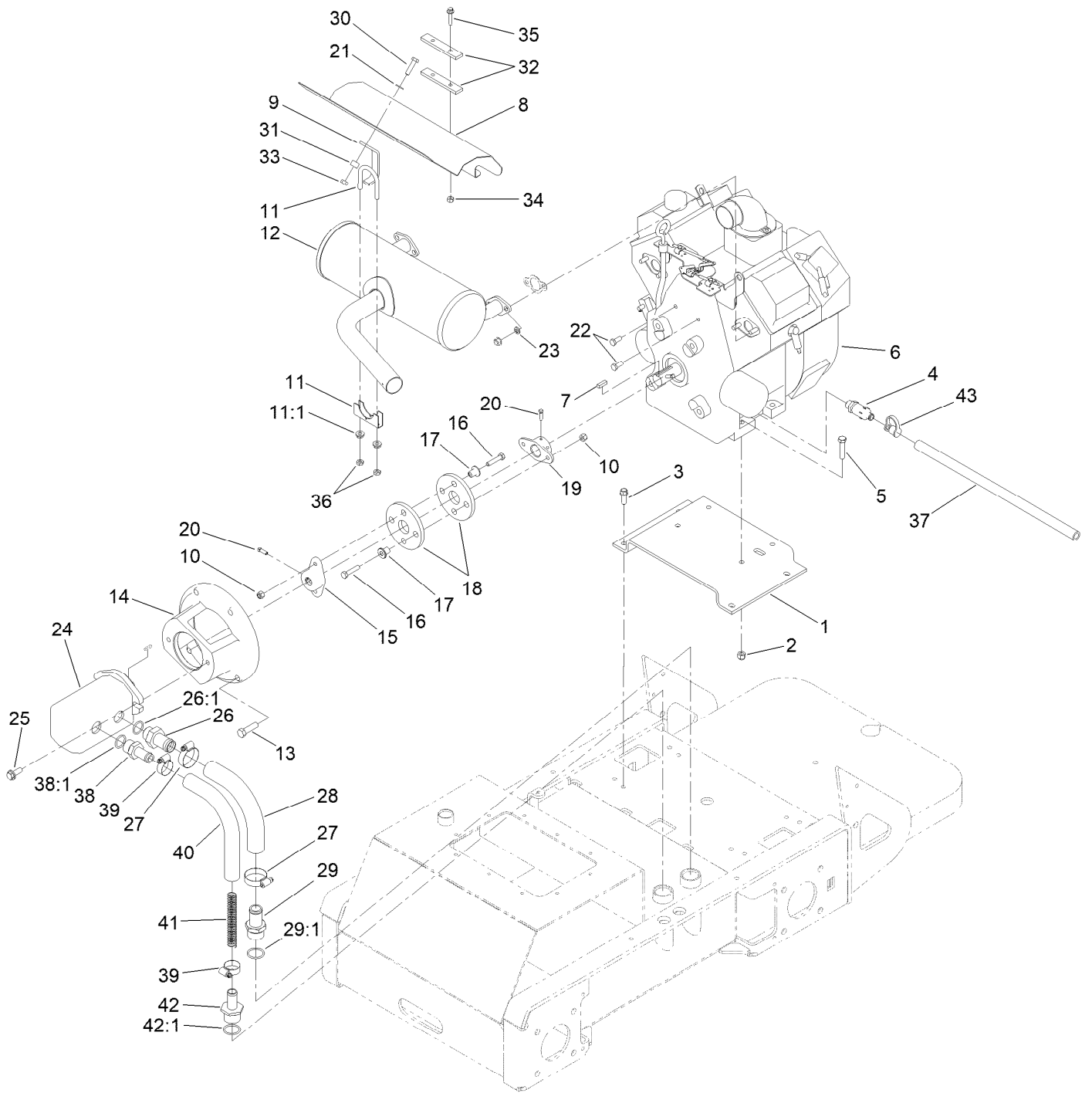

Engine and Hydraulic Pump Assembly (continued)

<i>Ref.</i>	<i>Part Number</i>	<i>Qty.</i>	<i>Description</i>	<i>Ref.</i>	<i>Part Number</i>	<i>Qty.</i>	<i>Description</i>
1	98-4666-03	1	Mount-Engine	24	108-4710	1	HYD Pump ASM
2	3296-39	4	Nut-Lock, NI	25	66-9300	2	Screw-HHF
3	95-1726	4	Screw-Taptite	26	99-3017	1	Fitting
4	92-6877	1	Valve-Drain, Oil	26:1	237-81	1	O-Ring
5	323-9	4	Screw-HH	27	2412-111	2	Clamp-Hose, W/Liner
6		1	Engine-Kohler, Ch680-3136 ● ■	28	99-3046	1	Hose-Suction, Formed
7	10-7070	1	Key-Square	29	354-78	1	Fitting-STR
8	99-3115-03	1	Shield-Muffler	29:1	237-146	1	O-Ring
9	99-3138-03	1	Support-Shield	30	322-6	1	Screw-HH
10	3296-29	4	Nut-Lock, NI	31	98-4695	1	Spacer
11	2112-9	1	Clamp	32	99-3116-03	2	Spacer-Bar
11:1	32128-20	2	Nut-HF	33	32152-1	1	Nut-Lock, Cone
12	105-8381	1	Muffler	34	32152-4	2	Nut-Lock, Cone
13	324-6	4	Screw-HH	35	3234-21	2	Screw-HHF
14	98-2751-03	1	Mount-Pump	36	3218-2	2	Nut-Hex Jam
15	98-4701	1	Hub-Pump	37	98-4667	1	Hose
16	322-7	4	Screw-HH	38	354-73	1	Fitting
17	71-4411	4	Spacer	38:1	237-81	1	O-Ring
18	115-4523	2	Coupling-Rubber	39	2412-129	2	Clamp-Hose
19	110-5236	1	Hub-Engine	40	98-2713	1	Hose-Suction, HYD
20	3241-6	4	Screw-SQH	41	99-5349	1	Spring-Compression
21	3256-23	1	Washer-Plain	42	99-6932	1	Fitting-STR
22	33114-020	2	Screw-HH	42:1	237-117	1	O-Ring
23	3253-4	4	Washer-Lock	43	354-79	1	Cap-Dust

● Not serviced separately

■ Obtain parts from www.kohlerplus.com

Tandem Hydraulic Pump Assembly No. 108-4710

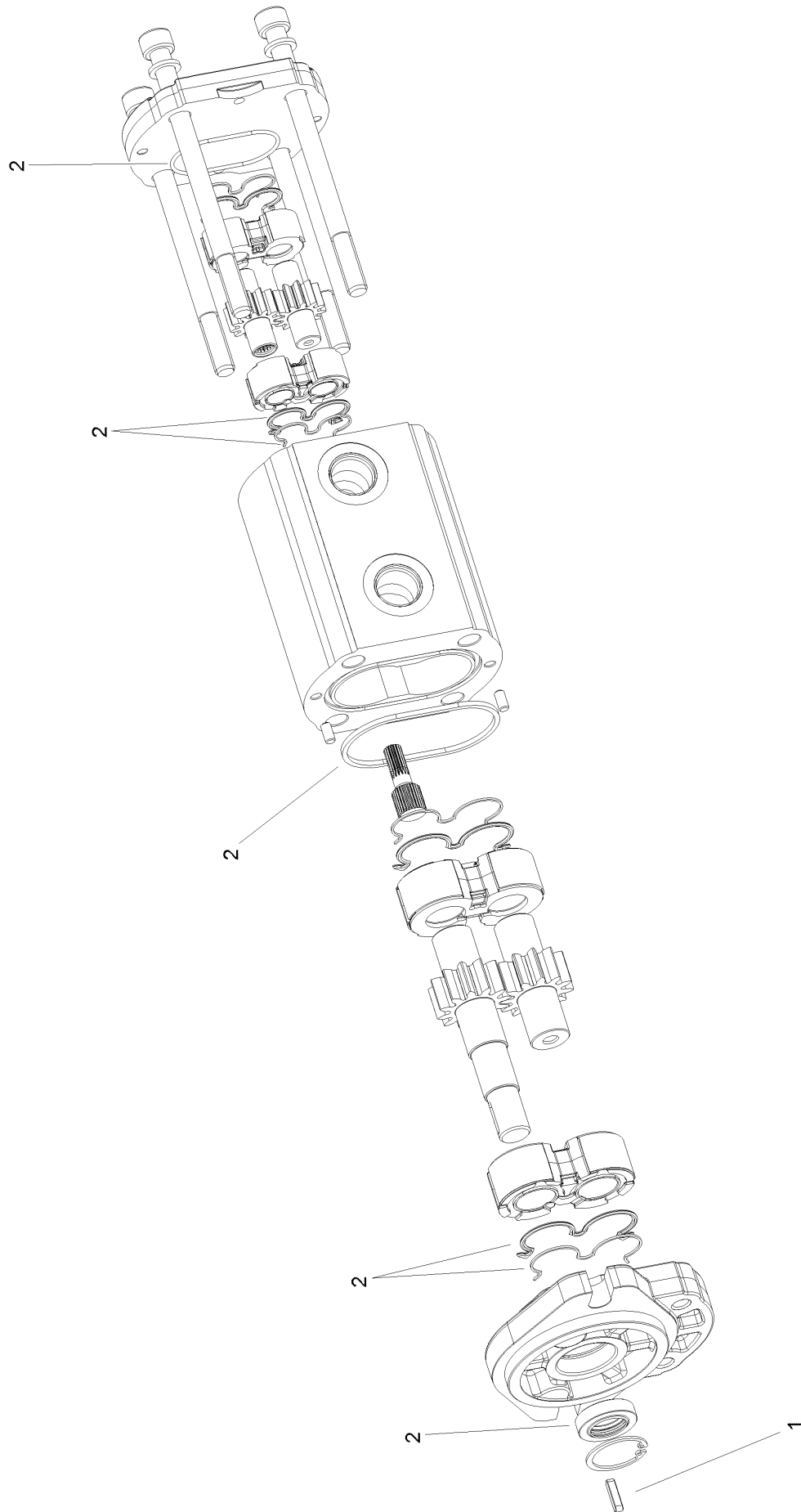

Tandem Hydraulic Pump Assembly No. 108-4710 (continued)

<i>Ref.</i>	<i>Part Number</i>	<i>Qty.</i>	<i>Description</i>
1	98-4700	1	Key-Square
2	99-1353	1	Seal Kit

Fuel Tank and Air Filter Assembly

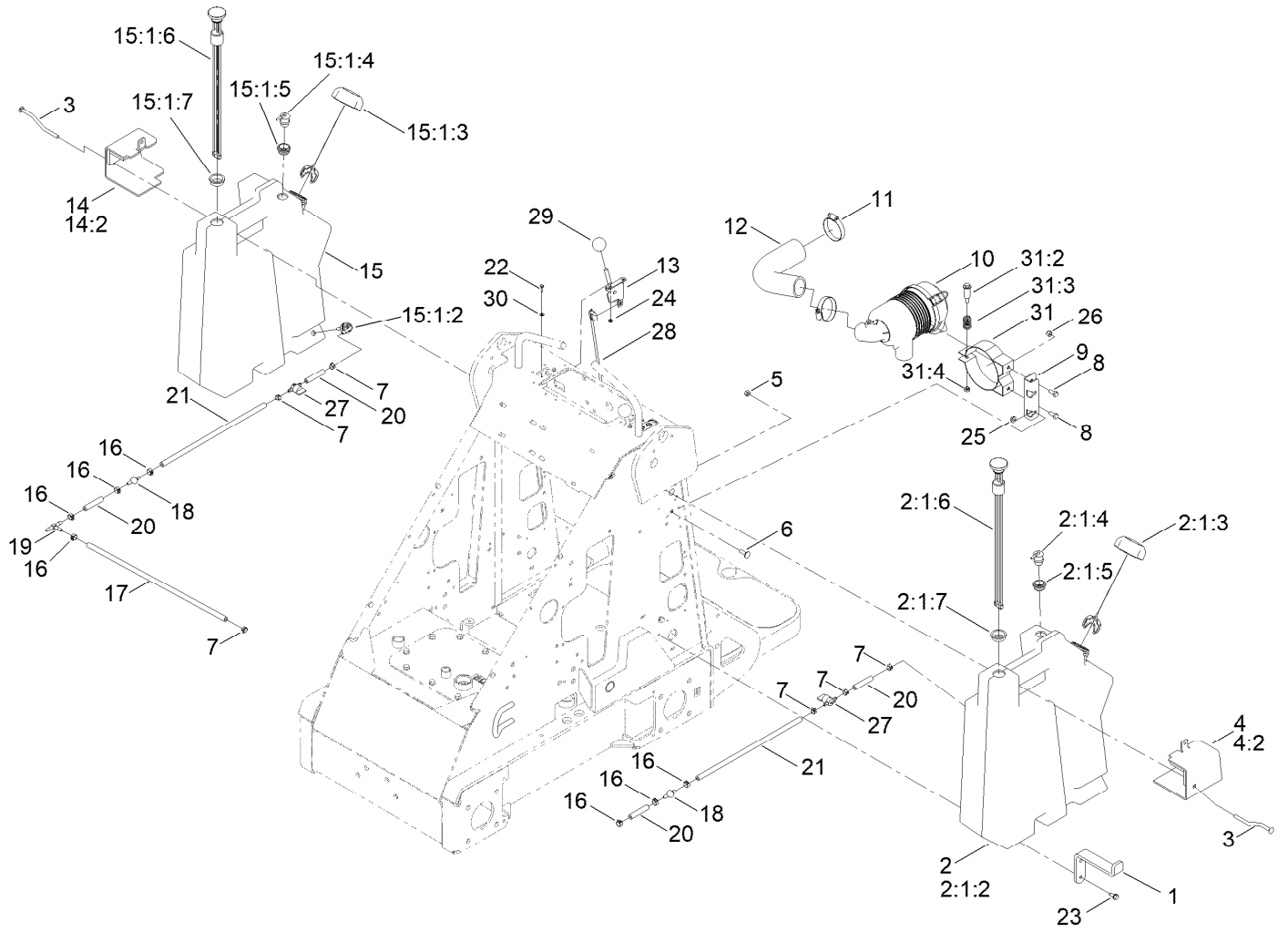

Fuel Tank and Air Filter Assembly (continued)

<i>Ref.</i>	<i>Part Number</i>	<i>Qty.</i>	<i>Description</i>	<i>Ref.</i>	<i>Part Number</i>	<i>Qty.</i>	<i>Description</i>
1	117-1777-03	2	Mount-Tank, Bottom	15:1:4	114-0285	1	Valve-Rollover
2	140-7236	1	Tank-Fuel, LH	15:1:5	114-0284	1	Grommet
2:1:2	103-2605	1	Fitting-Fuel, Bulkhead	15:1:6	104-5603	1	Gauge-Level, Fuel
2:1:3	115-7788	1	Cap-Fuel	15:1:7	95-8972	1	Grommet
2:1:4	114-0285	1	Valve-Rollover	16	92-2379	7	Clamp-Hose
2:1:5	114-0284	1	Grommet	17	110-5701	1	Hose-Fuel
2:1:6	104-5603	1	Gauge-Level, Fuel	18	99-5000	2	Valve-Check, Fuel
2:1:7	95-8972	1	Grommet	19	99-5005	1	Fitting-Tee, Barbed
3	98-4657	2	Bolt-Mount	20	109-0304	4	Hose-Fuel
4	117-1801	1	LH Tank Mount ASM	21	109-0296	2	Hose-Fuel
4:2	117-1798	2	Pad-Foam	22	3290-134	4	Screw
5	32153-3	2	Nut-Hex, Side Deform	23	32144-70	4	Screw-HWHTF
6	3230-2	2	Bolt-CARR	24	32149-7	4	Nut-Keps
7	2412-98	7	Clamp-Hose	25	32128-20	2	Nut-HF
8	322-3	2	Screw-HH	26	3296-29	2	Nut-Lock, NI
9	99-3080-03	1	Mount-Cleaner, Air	27	1-603770	2	Valve-Fuel
10	93-2190	1	Air Cleaner ASM	28	108-4718	2	Cable-Control
11	2412-42	2	Clamp-Hose	29	233-42	2	Knob
12	99-3148	1	Hose-Air	30	3256-51	4	Washer-Flat
13	108-9730	2	Lever-Control	31	93-2191	1	Air Cleaner Mounting Band ASM
14	117-1802	1	RH Tank Mount ASM				
14:2	117-1798	2	Pad-Foam	31:2	94-3653	1	Bolt
15	140-7235	1	Tank-Fuel,RH	31:3	94-3654	1	Spring
15:1:2	103-2605	1	Fitting-Fuel, Bulkhead	31:4	33024-00	1	Nut-Lock, NI
15:1:3	115-7788	1	Cap-Fuel				

Air Cleaner Assembly No. 93-2190

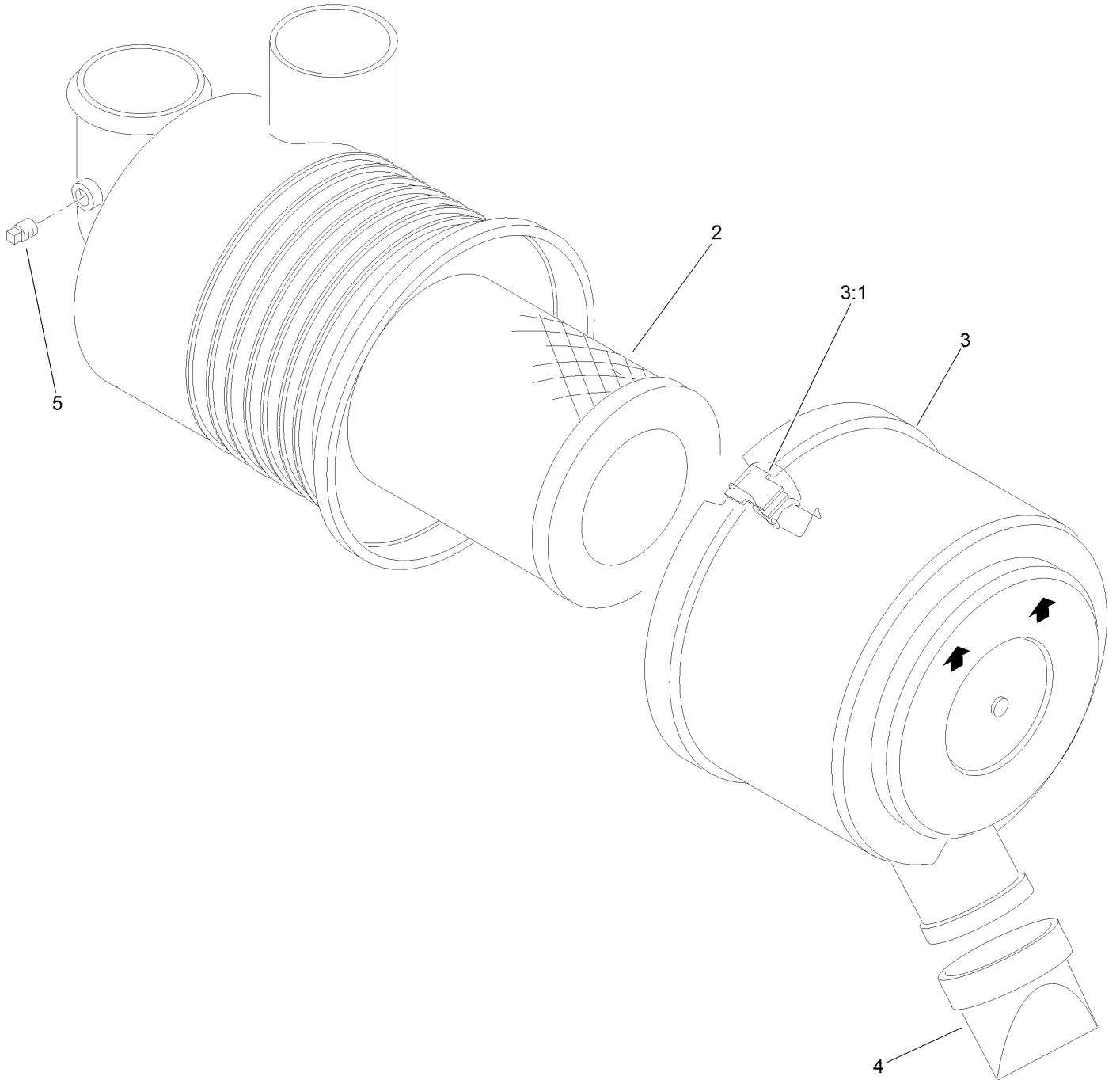

Air Cleaner Assembly No. 93-2190 (continued)

<i>Ref.</i>	<i>Part Number</i>	<i>Qty.</i>	<i>Description</i>	<i>Ref.</i>	<i>Part Number</i>	<i>Qty.</i>	<i>Description</i>
2	108-3811	1	Filter-Air V-Twin HD	4	87-9400	1	Valve-Vacuator
3	94-3652	1	Cover ASM	5	285-17	1	Plug-Pipe
3:1	1-643283	2	Latch-Cleaner, Air				

Carbon Canister Assembly

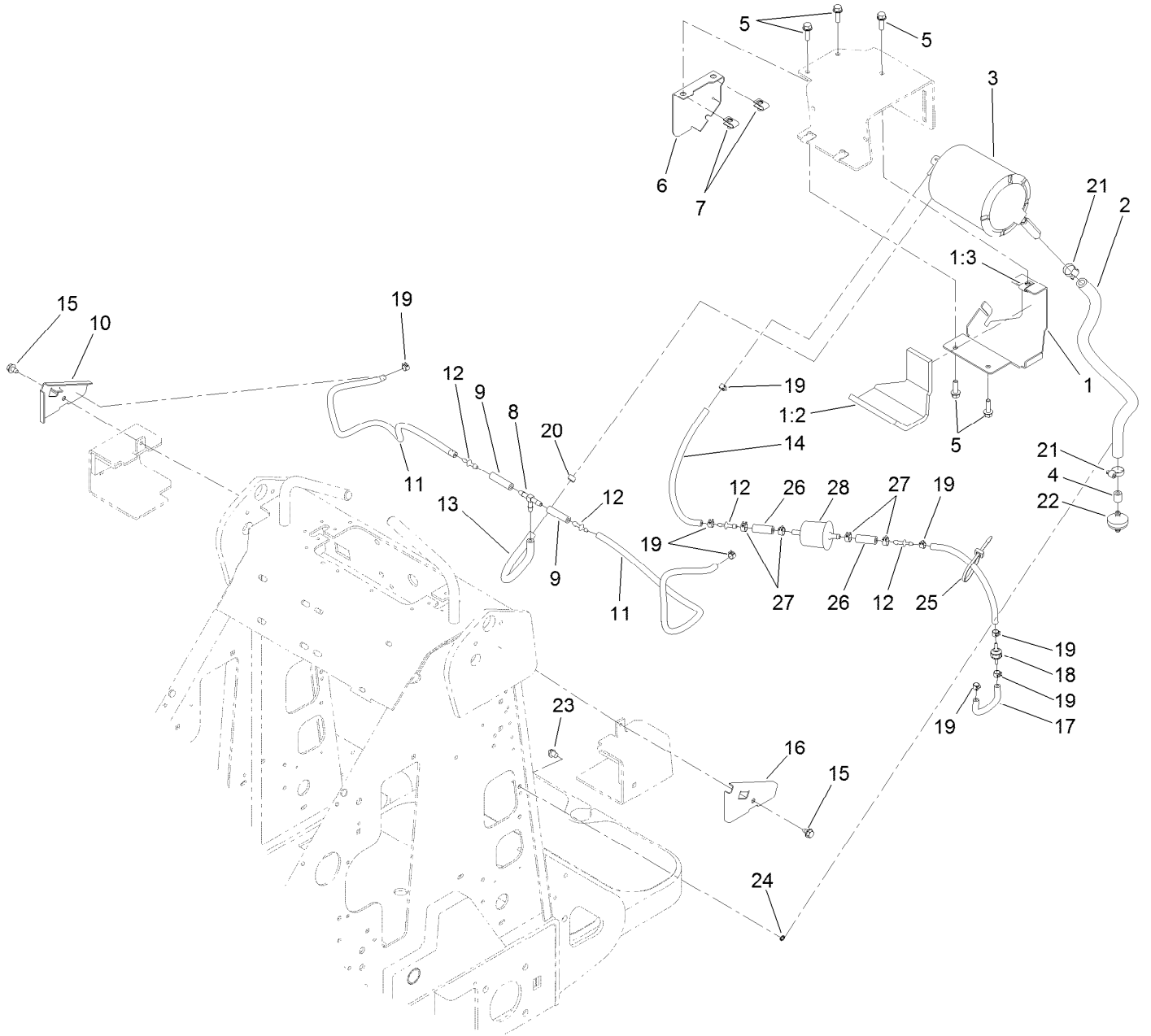

Carbon Canister Assembly (continued)

<i>Ref.</i>	<i>Part Number</i>	<i>Qty.</i>	<i>Description</i>	<i>Ref.</i>	<i>Part Number</i>	<i>Qty.</i>	<i>Description</i>
1	117-1821	1	Canister Mount ASM	14	51-3217	2	Hose-Fuel
1:2	117-1799	1	Pad-Foam	15	9266934	2	Screw
1:3	115-7721	1	Nut-Clip, U	16	117-1791-03	1	Plate-Hose Retainer, LH
2	106-5709	1	Hose-Vent	17	115-4736	1	Hose-Fuel
3	116-1442	1	Canister-Carbon, 1200Cc	18	133-8499	1	Valve-Check, Vacuum
4	117-1789	1	Hose-Fuel	19	2412-146	8	Clamp-Hose
5	3234-29	5	Screw-HHF	20	2412-98	1	Clamp-Hose
6	117-1785-03	1	Cover-Canister	21	2412-36	2	Clamp-Hose
7	115-7721	2	Nut-Clip, U	22	115-7854	1	Filter-Fuel, Inline
8	99-5005	1	Fitting-Tee, Barbed	23	32180-030	1	Clip-Tie
9	99-9415	2	Hose-Fuel	24	3254-8	1	Washer-Lock
10	117-1792-03	1	Plate-Hose Retainer, RH	25	3290-378	1	Tie-Cable
11	119-6074	2	Hose-Fuel	26	106-5317	2	Hose-Fuel
12	106-8150	4	Fitting-Straight	27	92-2379	4	Clamp-Hose
13	109-0294	1	Hose-Fuel	28	120-2235	1	Filter-Fuel

Loader and Quick Attach Assembly

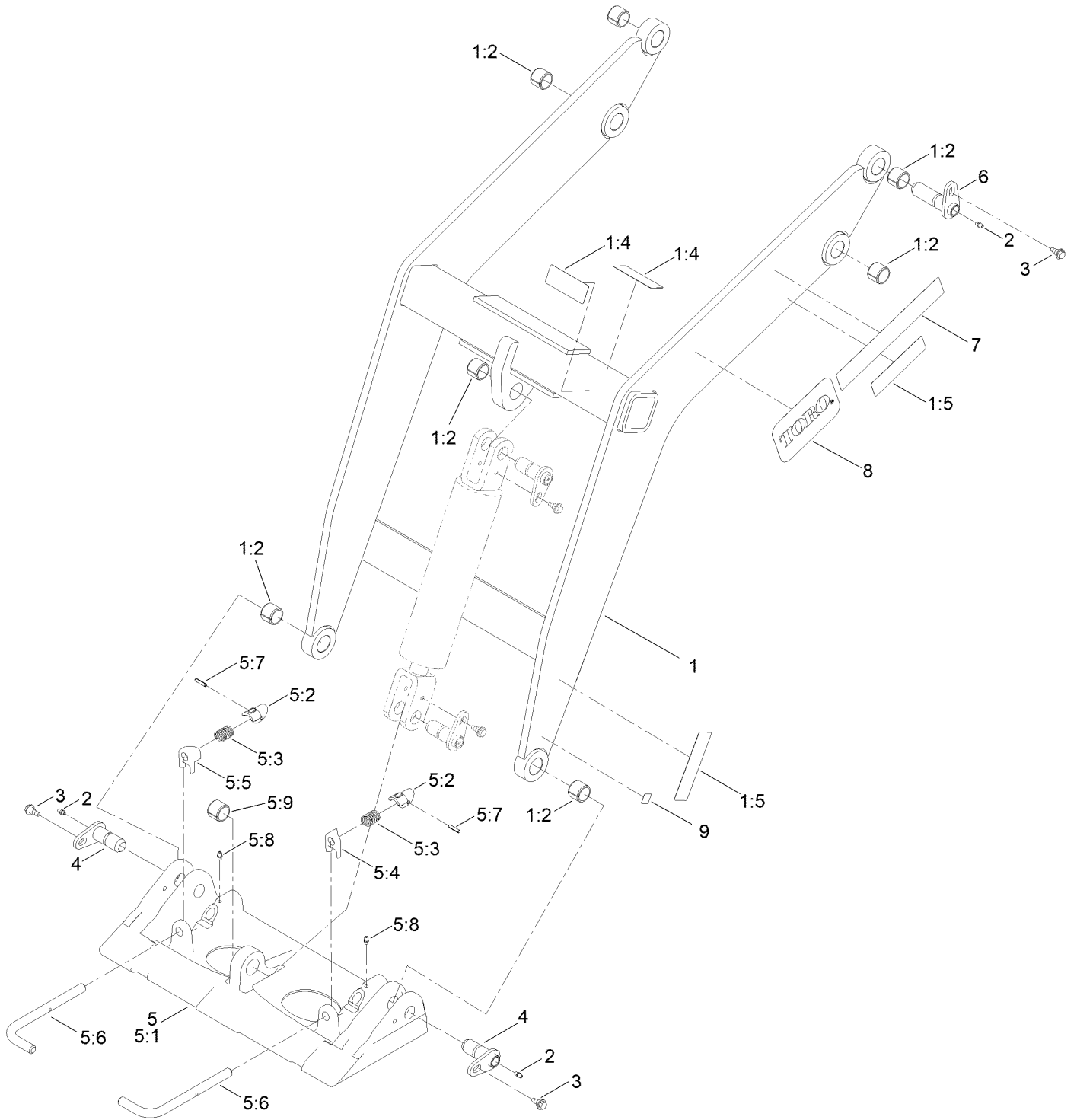

Loader and Quick Attach Assembly (continued)

<i>Ref.</i>	<i>Part Number</i>	<i>Qty.</i>	<i>Description</i>	<i>Ref.</i>	<i>Part Number</i>	<i>Qty.</i>	<i>Description</i>
1	106-8155	1	Loader ASM	5:4	104-5909	1	Stop-RH
1:2	98-4871	7	Bushing-Tension	5:5	104-5903	1	Stop-LH
1:4	130-2837	2	Decal-Warning, No Rider	5:6	132-8419	2	Pin-Locking
1:5	130-2836	4	Decal-Warning, Crushing	5:7	3285-1	2	Pin-Grooved
2	302-5	4	Fitting-Grease	5:8	302-5	2	Fitting-Grease
3	99-5105	4	Screw-Shoulder	5:9	98-4871	1	Bushing-Tension
4	112-2609	2	Pin-Pivot	6	120-5363	2	Pin-Pivot
5	132-8418	1	Quick Attach ASM	7	117-9980	2	Decal
5:1	130-7708-03	1	Mount-Qtach	8	93-7340	2	Decal
5:2	105-0246	2	Cam	9	93-9084	2	Decal-Point, Lift
5:3	98-4694	2	Spring-Compression				

Electrical Component Assembly

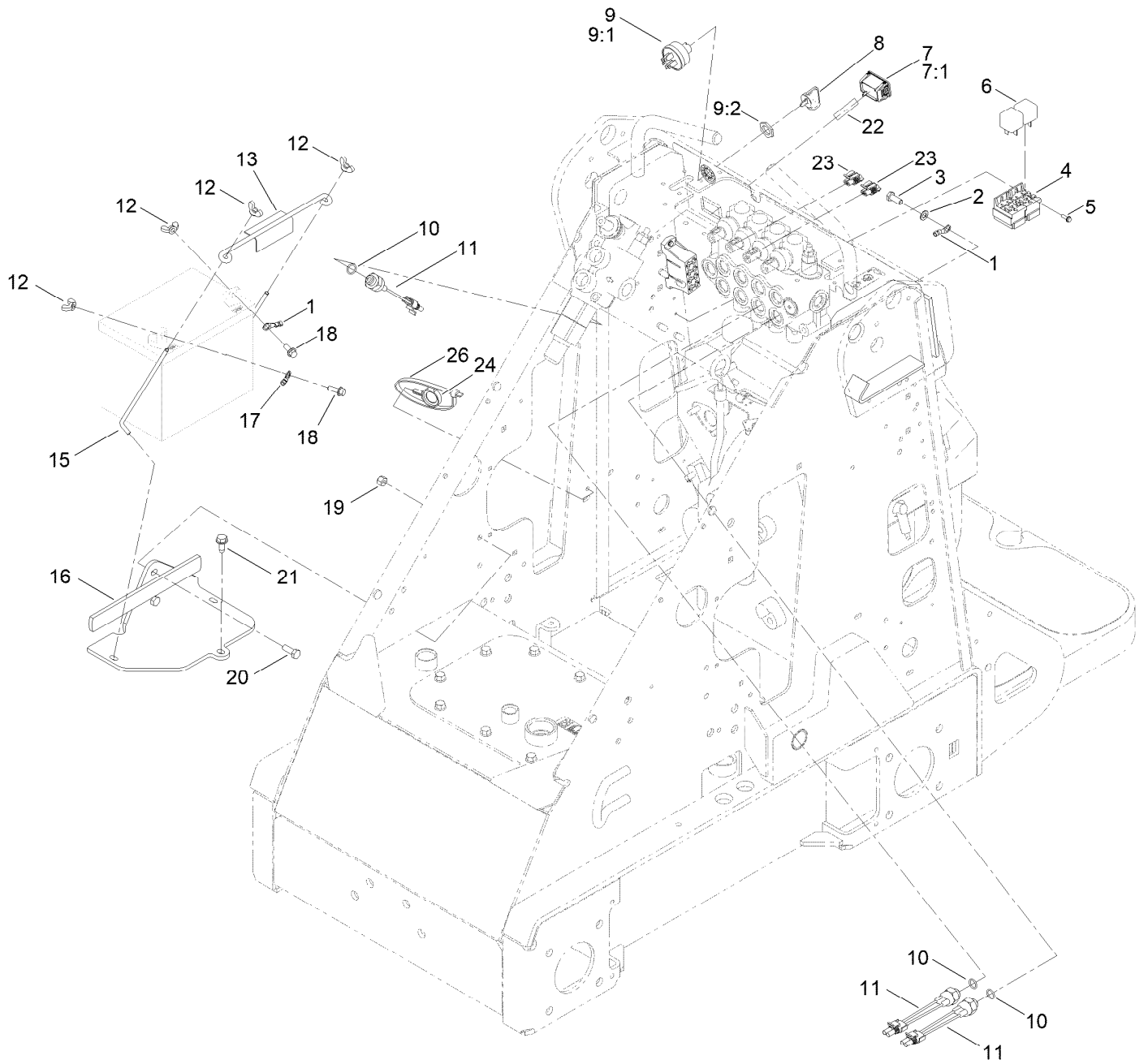

Electrical Component Assembly (continued)

<i>Ref.</i>	<i>Part Number</i>	<i>Qty.</i>	<i>Description</i>	<i>Ref.</i>	<i>Part Number</i>	<i>Qty.</i>	<i>Description</i>
1	111075	1	Wire ASM	12	32103-22	4	Nut-Wing
2	3255-8	1	Washer-Lock	13	113010	1	Holddown-Battery
3	33114-020	1	Screw-HH	15	99-5027	2	Retainer-Battery
4	104-7411	1	Harness-Wire	16	99-3060-03	1	Battery Mount ASM
5	32144-87	3	Screw-HWHTF	17	100-1712	1	Cable-Positive
6	98-7249	2	Relay	18	3234-4	2	Screw-HHF
7	105-4067	1	Hourmeter-Inductive	19	3296-29	2	Nut-Lock, NI
7:1	104-4234	1	Clip-Mounting	20	322-4	2	Screw-HH
8	63-8360	2	Key-Ignition	21	32144-70	1	Screw-HWHTF
9	111216	1	Ignition Switch ASM	22	104-7408	1	Wire-Hourmeter
9:1	9201604	1	Washer-Lock	23	99-1433	2	Connector-Female
9:2	101884	1	Nut	24	32180-030	1	Clip-Tie
10	237-42	3	O-Ring	26	3334-945	1	Tie-Cable
11	72-4310	3	Switch-Ball	99	3290-381	5	Tie-Cable ●

● Not illustrated

Hydraulic Tank and Filter Assembly

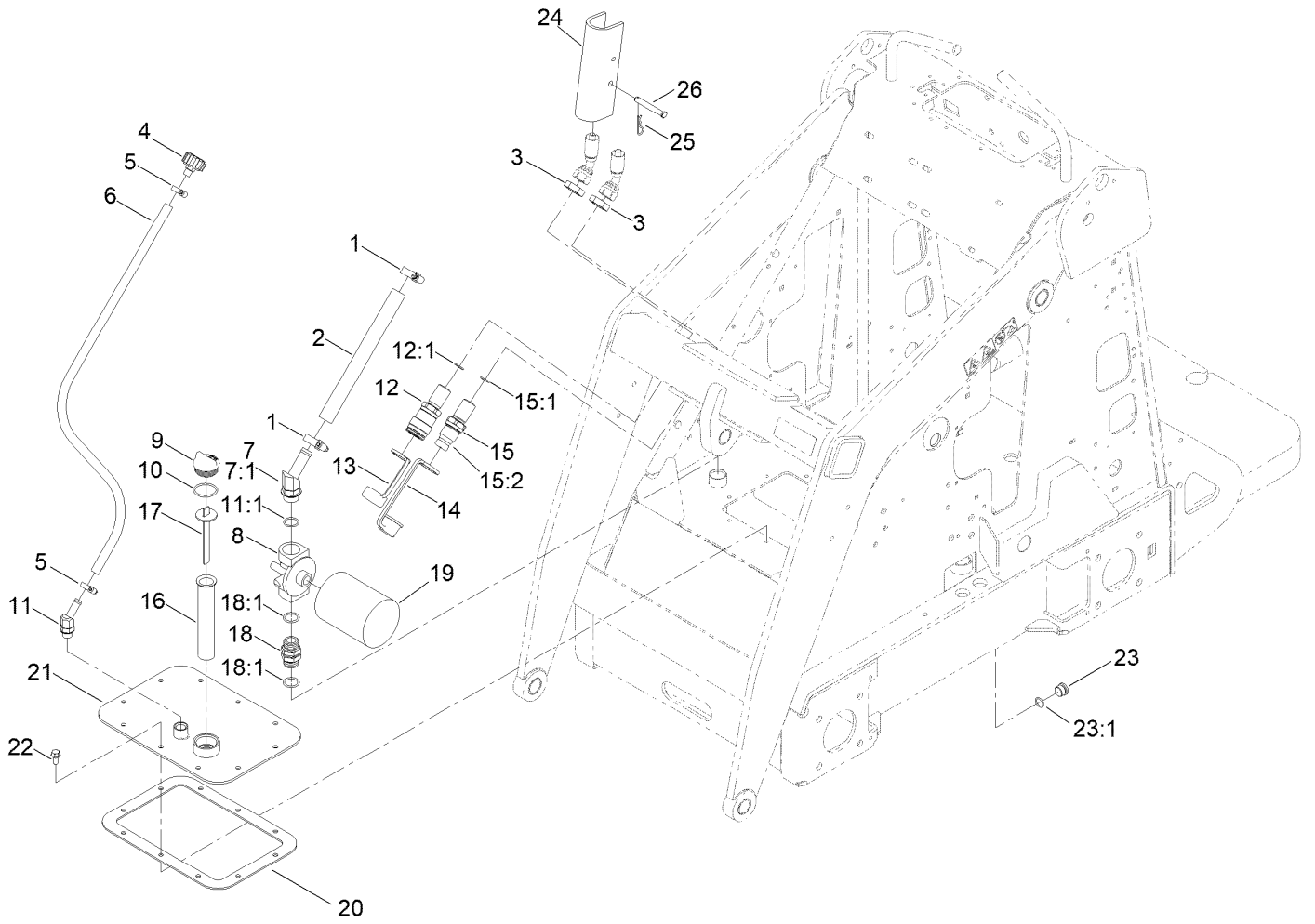

Hydraulic Tank and Filter Assembly (continued)

<i>Ref.</i>	<i>Part Number</i>	<i>Qty.</i>	<i>Description</i>	<i>Ref.</i>	<i>Part Number</i>	<i>Qty.</i>	<i>Description</i>
1	2412-129	2	Clamp-Hose	15	105-8395	1	Bulkhead Nipple ASM
2	98-4745	1	Hose-HYD, Suction, Hi	15:1	237-65	1	O-Ring
3	340-74	2	Nut-Lock, Bulkhead	15:2	100-6120	1	Seal Kit ●
4	68-6150	1	Breather	16	61-2790	1	Filter-Screen
5	2412-36	2	Clamp-Hose	17	100-2097	1	Dipstick-Oil
6	98-2708	1	Hose-Vent	18	98-9906	1	Fitting-Thread, Straight
7	354-127	1	Fitting-Elbow45	18:1	237-81	2	O-Ring
7:1	237-81	1	O-Ring	19	54-0110	1	Filter-Oil, Transmission
8	92-5821	1	Head-Filter	20	98-9927	1	Gasket-Cover
9	93-7498	1	Plug-Plastic	21	100-1713-01	1	Cover
10	237-101	1	O-Ring	22	98-9940	10	Screw-HHF
11	354-126	1	Fitting-Elbow, 45	23	353-988	1	Plug-Hex
11:1	237-79	1	O-Ring	23:1	237-79	1	O-Ring
12	105-8394	1	Bulkhead Coupler ASM	24	98-4675-01	2	Lock-Cylinder
12:1	237-65	1	O-Ring	25	3290-467	2	Pin-Hair
13	100-8816	1	Cap-Dust, Coupler	26	283-52	2	Pin-Clevis
14	100-8815	1	Cap-Dust, Nipple				

● Not illustrated

Auxiliary Control Lever Assembly

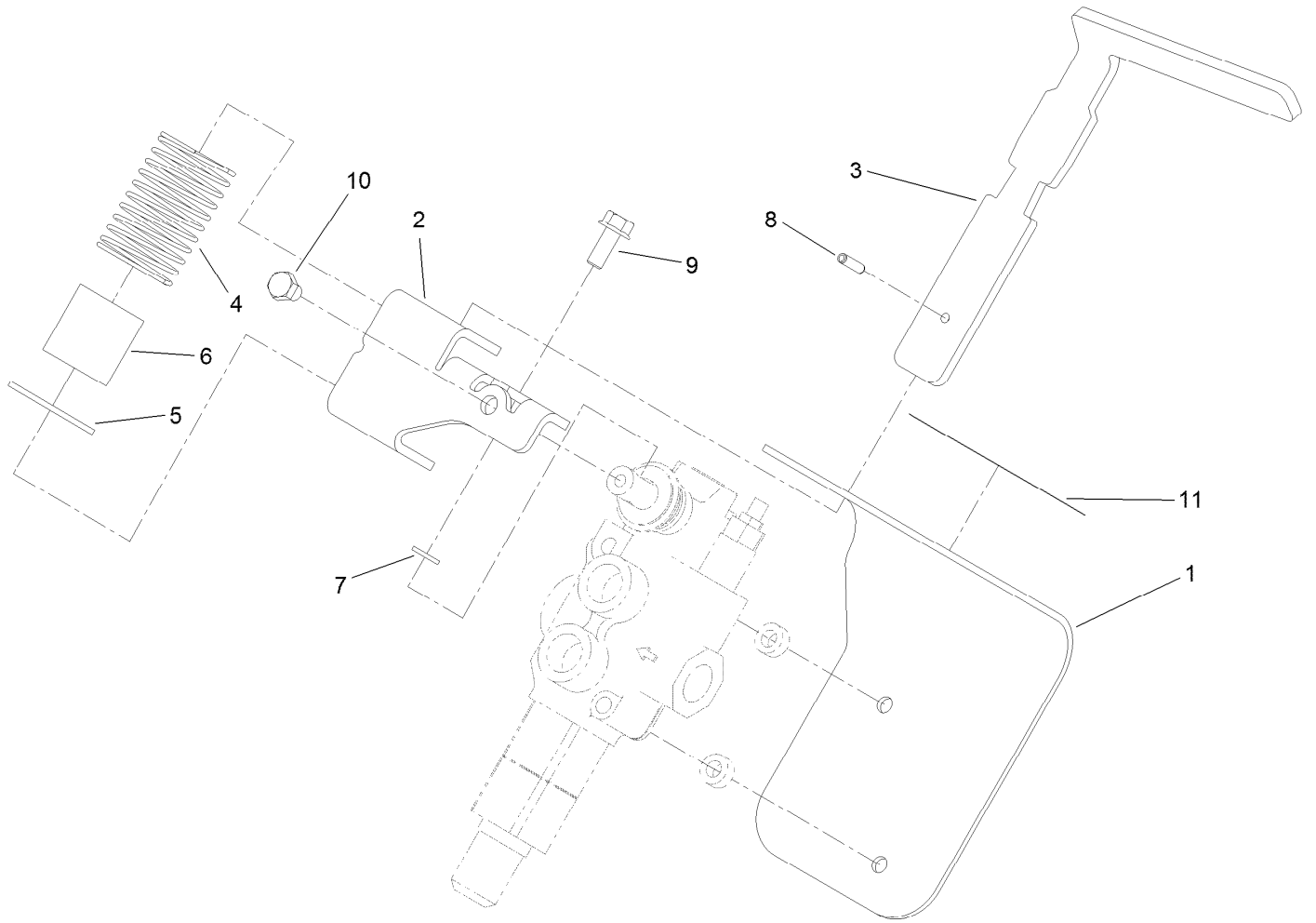

Auxiliary Control Lever Assembly (continued)

<i>Ref.</i>	<i>Part Number</i>	<i>Qty.</i>	<i>Description</i>	<i>Ref.</i>	<i>Part Number</i>	<i>Qty.</i>	<i>Description</i>
1	110-0121-03	1	Bracket-Auxiliary	7	3253-4	1	Washer-Lock
2	114-1263-03	1	Mount-Lever, Auxiliary	8	32121-3	1	Pin-Spring
3	110-0123	1	Handle-Lever, Auxiliary	9	33104-020	1	Screw-HHF
4	110-0124	1	Spring	10	33114-010	1	Screw-HH
5	110-0125	1	Retainer-Spring, Auxiliary	11	108-4723	1	Decal-Auxiliary, CE
6	110-0160	1	Tube-Spring				

Auxiliary Valve and Selector Valve Assembly

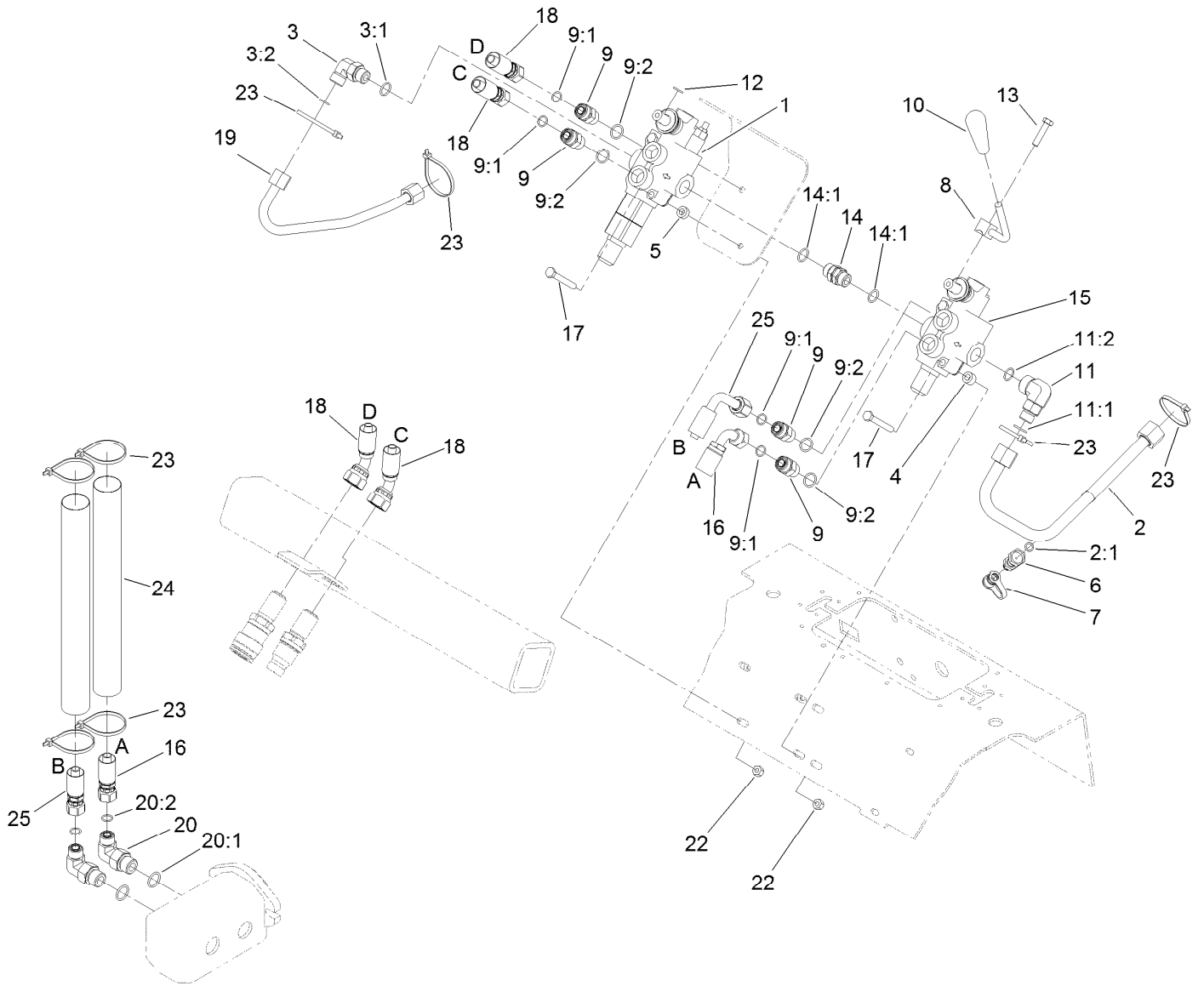

Auxiliary Valve and Selector Valve Assembly (continued)

<i>Ref.</i>	<i>Part Number</i>	<i>Qty.</i>	<i>Description</i>	<i>Ref.</i>	<i>Part Number</i>	<i>Qty.</i>	<i>Description</i>
1	99-3077	1	Valve-HYD, Auxiliary	11:2	237-151	1	O-Ring
2	108-4716	1	HYD Tube ASM	12	3253-4	1	Washer-Lock
2:1	237-22	1	O-Ring	13	33114-035	1	Screw-HH
3	340-98	1	Fitting-Elbow, 90 DEG	14	95-3209	1	Fitting-Thread, Straight
3:1	237-79	1	O-Ring	14:1	237-79	2	O-Ring
3:2	237-30	1	O-Ring	15	99-3072	1	Valve-Selector, HYD
4	98-4695	2	Spacer	16	98-4747	1	Hose-HYD
5	100-2085	2	Spacer	17	322-12	4	Screw-HH
6	86-5480	1	Nipple-Test	18	100-8817	2	Hose-HYD
7	354-79	1	Cap-Dust	19	105-7879	1	Tube-HYD
8	108-9709-03	1	Lever-Control	20	340-105	2	Fitting-Elbow, 90 DEG
9	340-4	4	Fitting-Straight	20:1	237-80	1	O-Ring
9:1	237-30	1	O-Ring	20:2	237-30	1	O-Ring
9:2	237-79	1	O-Ring	22	104-8300	4	Nut-HF, NI
10	98-0152	1	Knob-Tapered	23	3290-379	8	Tie-Cable
11	340-153	1	Fitting-Elbow, 90 DEG	24	108-9715	2	Sleeve-Thermal
11:1	237-79	1	O-Ring	25	99-3008	1	Hose-HYD

Auxiliary Hydraulic Valve Assembly No. 99-3077

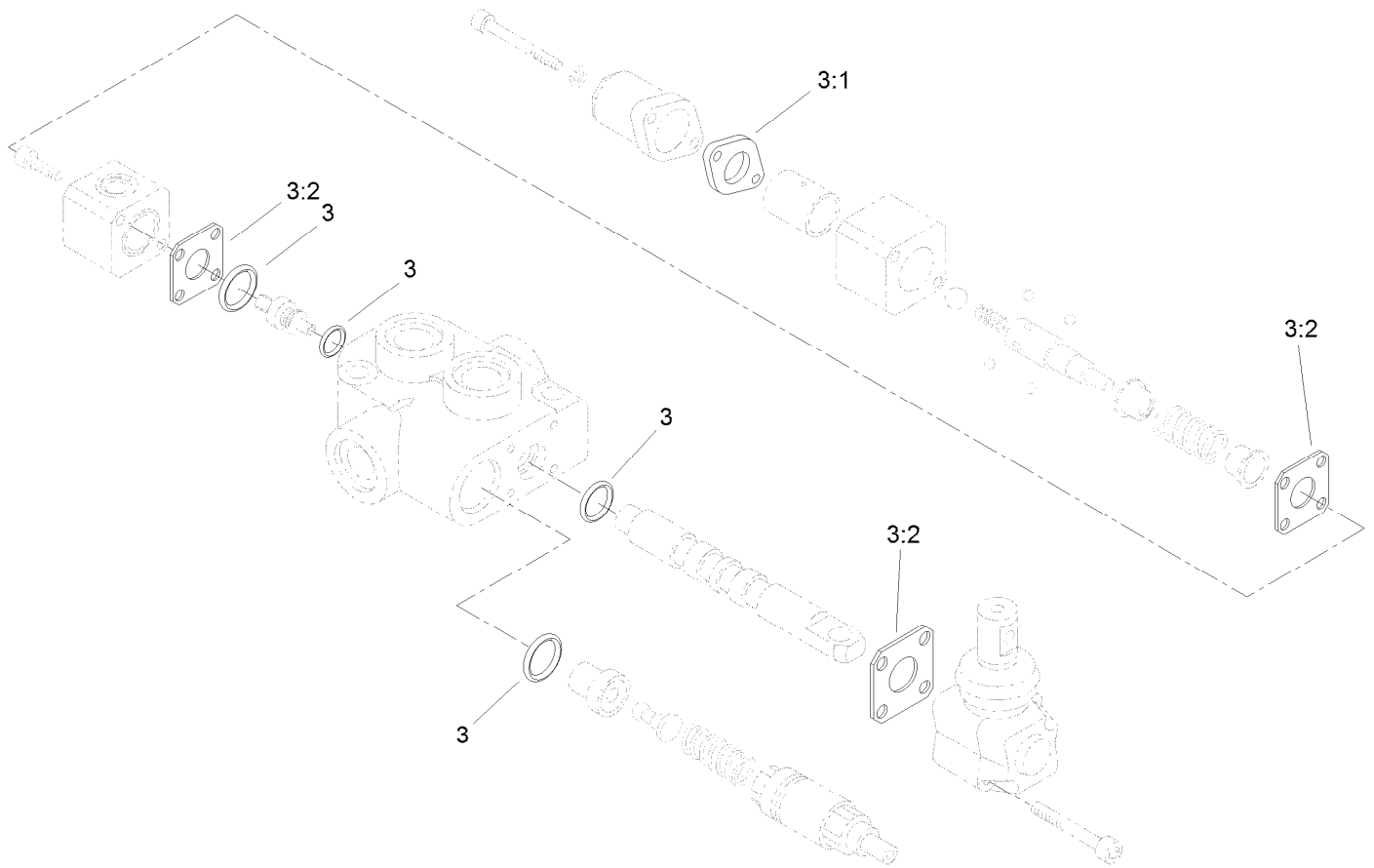

Auxiliary Hydraulic Valve Assembly No. 99-3077 (continued)

<i>Ref.</i>	<i>Part Number</i>	<i>Qty.</i>	<i>Description</i>
3	99-4390	1	Seal Kit
3:1	99-3074	4	Gasket
3:2	99-3075	8	Gasket

Hydraulic Selector Valve Assembly No. 99-3072

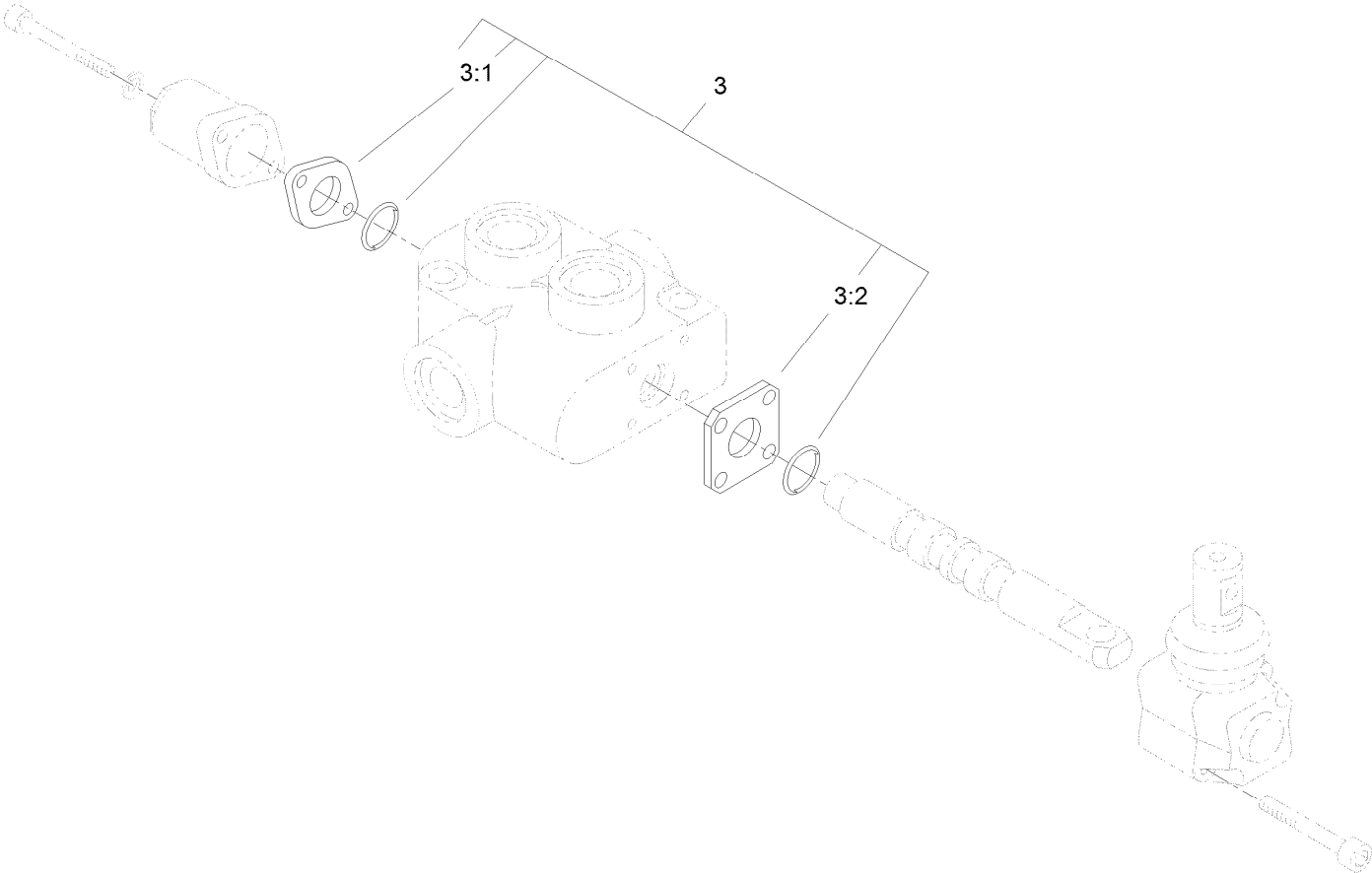

Hydraulic Selector Valve Assembly No. 99-3072 (continued)

<i>Ref.</i>	<i>Part Number</i>	<i>Qty.</i>	<i>Description</i>
3	99-4390	1	Seal Kit
3:1	99-3074	4	Gasket
3:2	99-3075	8	Gasket

Four Spool Valve and Lever Assembly

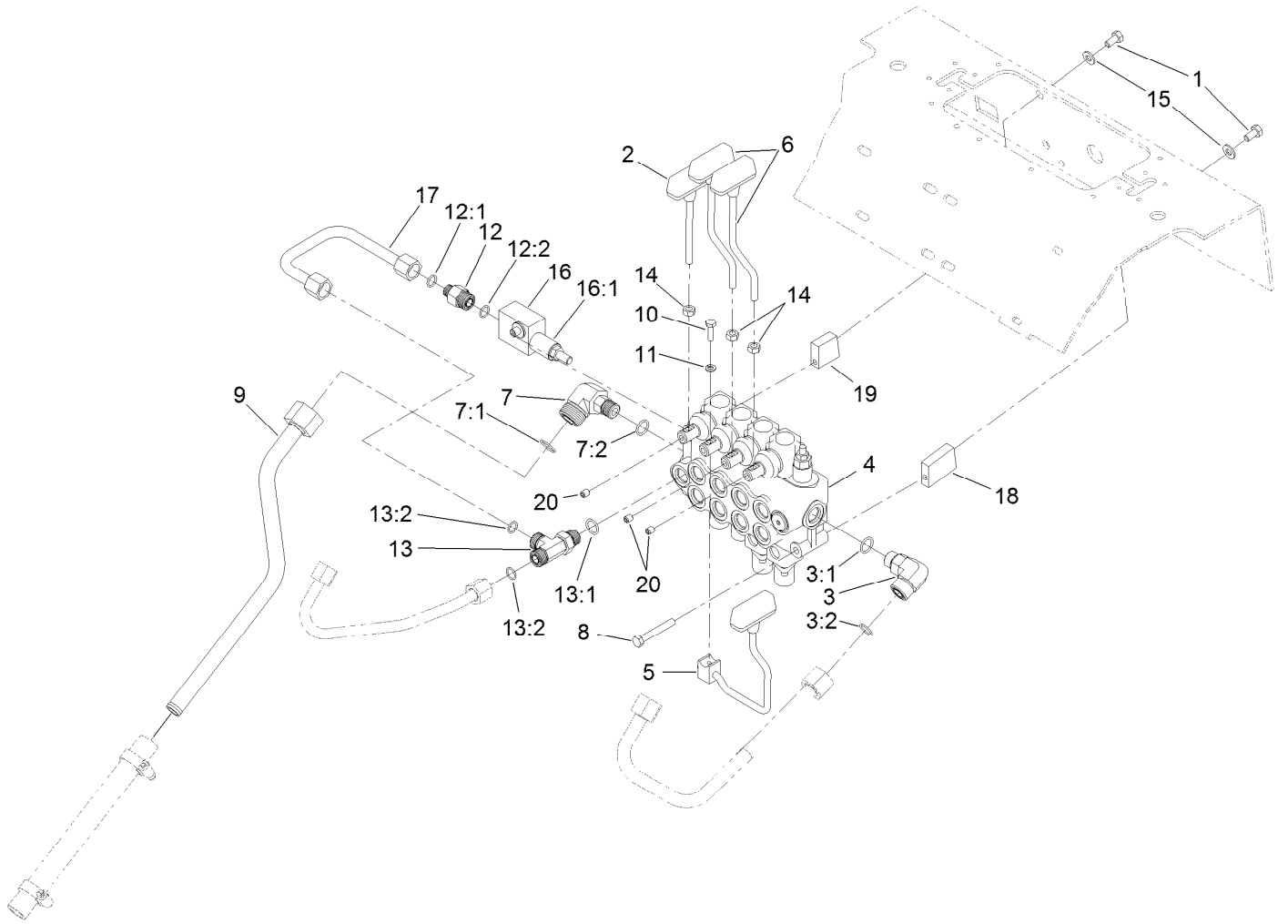

Four Spool Valve and Lever Assembly (continued)

<i>Ref.</i>	<i>Part Number</i>	<i>Qty.</i>	<i>Description</i>	<i>Ref.</i>	<i>Part Number</i>	<i>Qty.</i>	<i>Description</i>
1	322-2	3	Screw-HH	12	340-5	1	Fitting-Straight
2	105-7881	1	Lever-Cylinder	12:1	237-42	1	O-Ring
3	340-153	1	Fitting-Elbow, 90 DEG	12:2	237-30	1	O-Ring
3:1	237-79	1	O-Ring	13	340-109	1	Fitting-Tee
3:2	237-151	1	O-Ring	13:1	237-79	1	O-Ring
4	105-8377	1	HYD Four Spool Valve ASM	13:2	237-30	2	O-Ring
5	106-8165	1	Lever-Control	14	33014-00	3	Nut-Hex
6	104-5733	2	Lever-Drive	15	33094-00	3	Washer-Plain
7	92-5696	1	Fitting-Elbow, 90 DEG	16	105-7882	1	Relief Valve ASM
7:1	237-58	1	O-Ring	16:1	105-8358	1	Cartridge-Valve, Relief
7:2	237-79	1	O-Ring	16:2	105-8357	1	Seal Kit ●
8	322-11	3	Screw-HH	17	108-4717	1	Tube-HYD
9	106-8177	1	Tube-Tank, HYD	18	108-4728	2	Spacer V
10	321-5	1	Screw-HH	19	105-7870	1	Spacer-Upper V
11	3253-3	1	Washer-Lock	20	105-4068	3	Screw-Set,Cphs

● Not illustrated

Four Spool Hydraulic Valve Assembly No. 105-8377

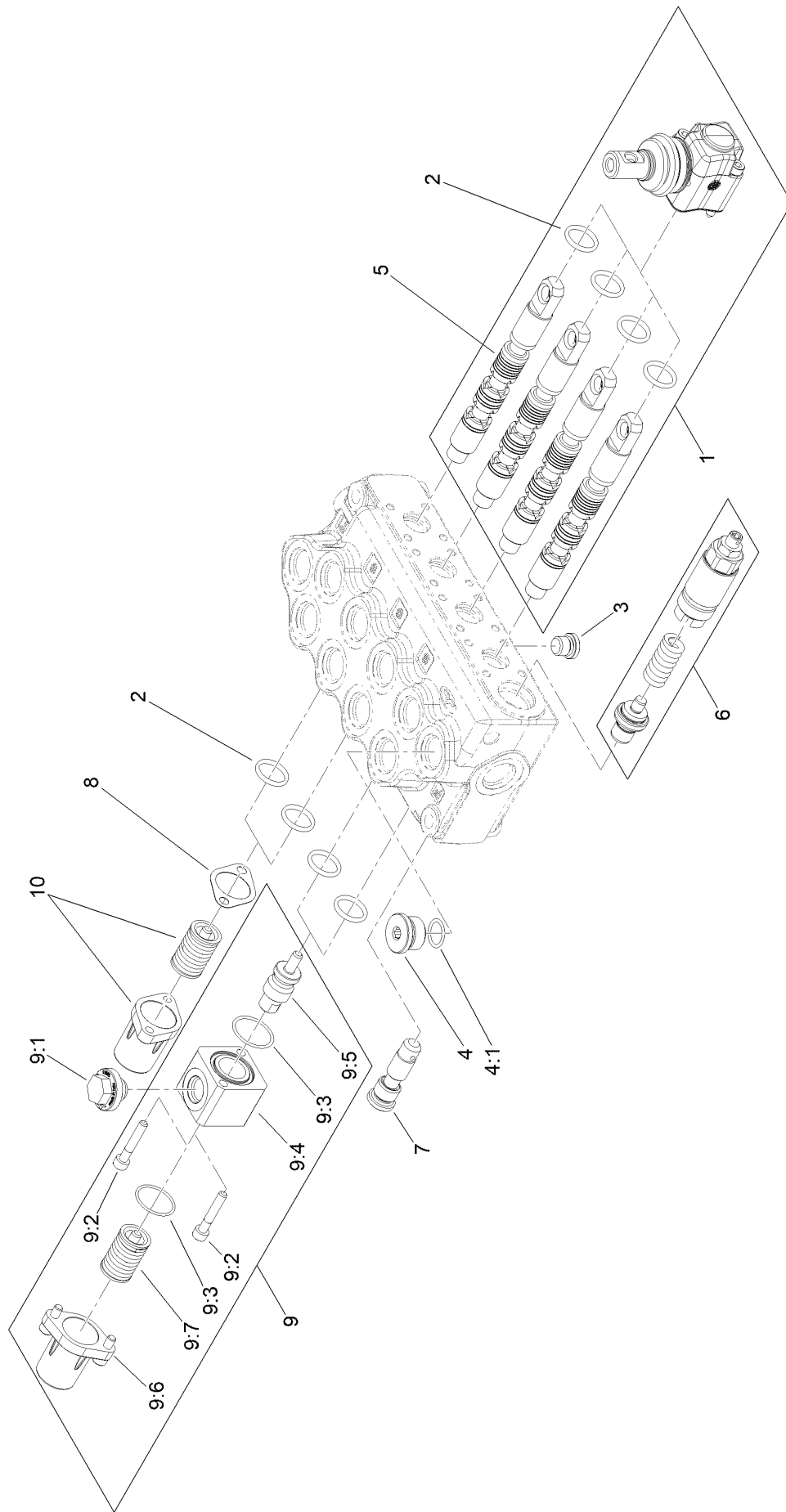

Four Spool Hydraulic Valve Assembly No. 105-8377 (continued)

<i>Ref.</i>	<i>Part Number</i>	<i>Qty.</i>	<i>Description</i>	<i>Ref.</i>	<i>Part Number</i>	<i>Qty.</i>	<i>Description</i>
1	139-8891	4	Lsg/S5 Lever Kit With Screws	9	139-8887	2	S5 Command Kit
2	139-8886	8	O-Ring Seal, 70 Sh	9:1		1	Plug ●
3	139-8884	1	SAE 4 Plug	9:2		2	Screw ●
4	353-988	1	Plug-Hex	9:3		2	Oring ●
4:1	237-79	1	O-Ring	9:4		1	Block ●
5	105-8441	4	Spool-Valve	9:5		1	Pin ●
6	139-8890	1	Vmd5 (Jn) Inlet Part	9:6		1	End Cap ●
7	139-8880	1	Kit-Valve Body	9:7		1	Spring ●
8	99-3074	2	Gasket	10	161-1080	2	S5 End Cap Kit

● Not serviced separately

Hydraulic Motor Assembly

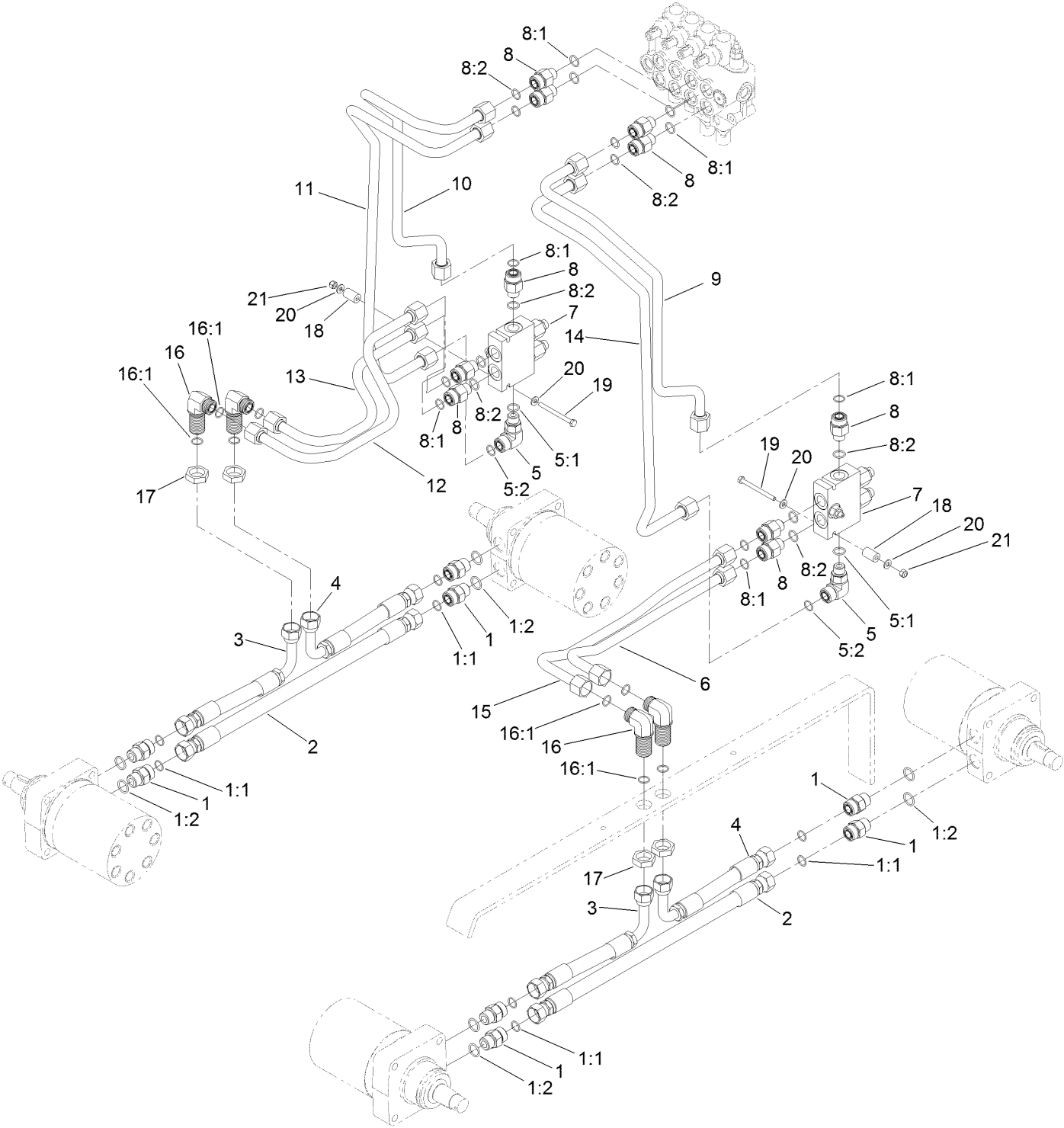

Hydraulic Motor Assembly (continued)

<i>Ref.</i>	<i>Part Number</i>	<i>Qty.</i>	<i>Description</i>	<i>Ref.</i>	<i>Part Number</i>	<i>Qty.</i>	<i>Description</i>
1	340-7	8	Fitting-Straight	9	108-9729	1	Tube-HYD
1:1	237-65	1	O-Ring	10	108-9727	1	Tube-HYD
1:2	237-80	1	O-Ring	11	108-9726	1	Tube-HYD
2	99-3012	2	Hose-HYD	12	99-3025	1	Tube-HYD
3	99-3010	2	Hose-HYD	13	99-3028	1	Tube-HYD
4	99-3011	2	Hose-HYD	14	108-9725	1	Tube-HYD
5	340-153	2	Fitting-Elbow, 90 DEG	15	99-3026	1	Tube-HYD
5:1	237-79	1	O-Ring	16	340-72	4	Fitting-Bulkhead, 90 DEG
5:2	237-151	1	O-Ring	16:1	237-65	2	O-Ring
6	99-3022	1	Tube-HYD	17	340-74	4	Nut-Lock, Bulkhead
7	99-3040	2	HYD Counterbalance Valve ASM	18	99-3057	2	Spacer-Valve
8	340-155	10	Fitting-Straight	19	321-23	2	Screw-HH
8:1	237-79	1	O-Ring	20	3256-22	4	Washer-Flat
8:2	237-151	1	O-Ring	21	3296-42	2	Nut-Lock, NI

Counterbalance Valve Assembly No. 99-3040

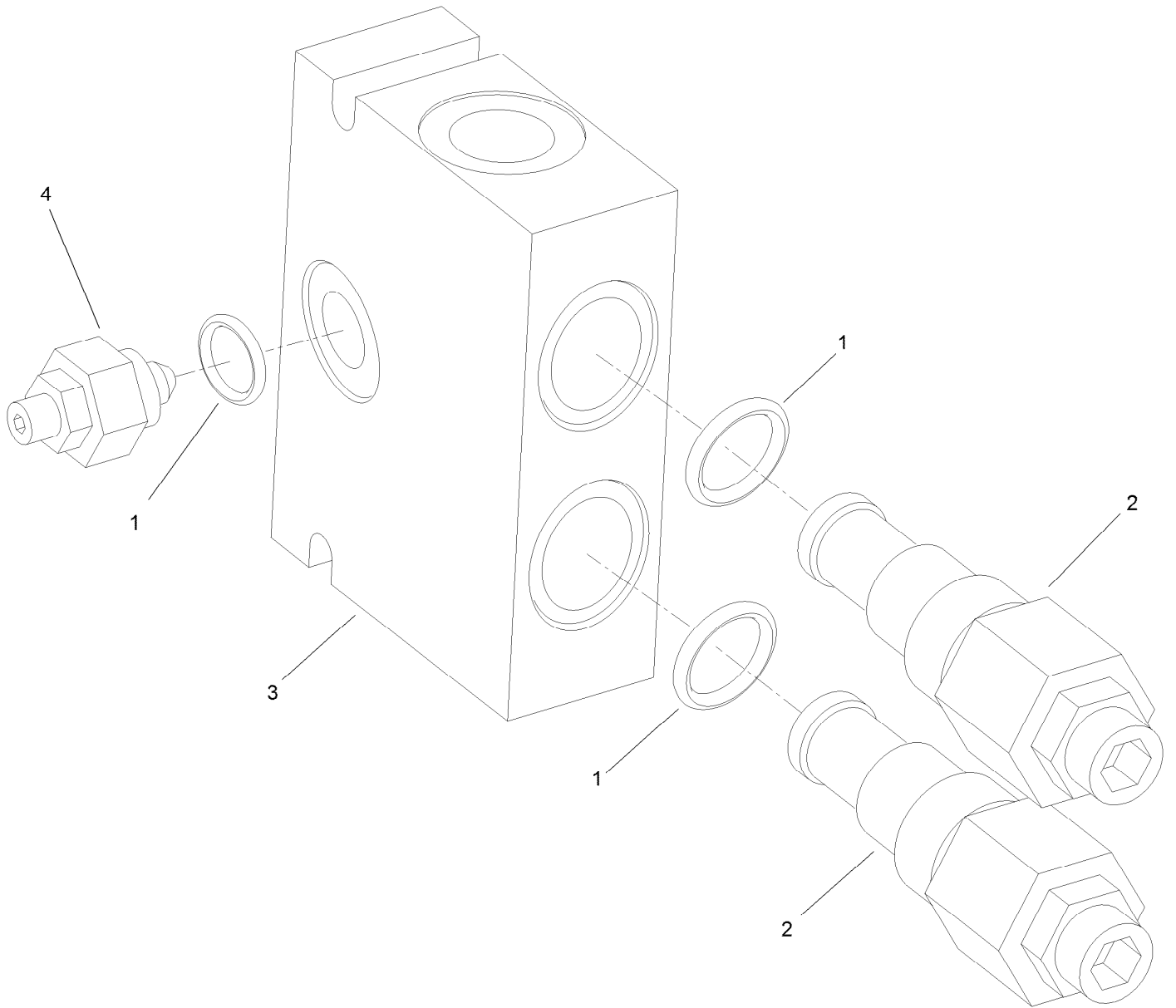

Counterbalance Valve Assembly No. 99-3040 (continued)

<i>Ref.</i>	<i>Part Number</i>	<i>Qty.</i>	<i>Description</i>
1	105-4099	1	Seal Kit
2	99-3271	2	Valve-Cartridge

<i>Ref.</i>	<i>Part Number</i>	<i>Qty.</i>	<i>Description</i>
3	100-8864	1	Manifold ASM
4	100-8865	1	Needle Valve ASM

Hydraulic Cylinder Assembly

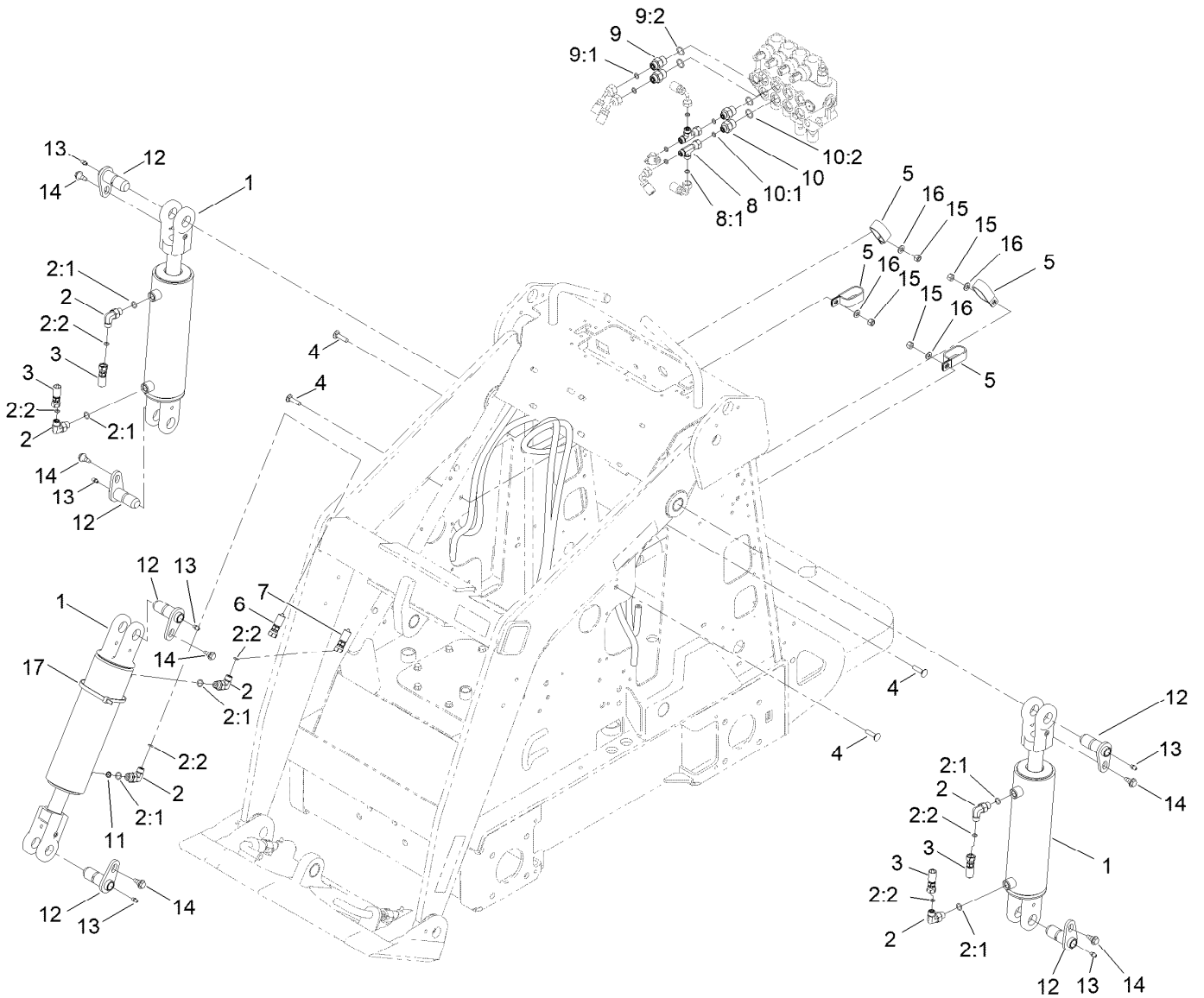

Hydraulic Cylinder Assembly (continued)

<i>Ref.</i>	<i>Part Number</i>	<i>Qty.</i>	<i>Description</i>	<i>Ref.</i>	<i>Part Number</i>	<i>Qty.</i>	<i>Description</i>
1	139-7706	3	Cylinder-Hydraulic	9:1	237-22	1	O-Ring
2	340-82	6	Fitting-Elbow, 90 DEG	9:2	237-79	1	O-Ring
2:1	237-42	1	O-Ring	10	340-133	2	Fitting-STR
2:2	237-21	1	O-Ring	10:1	237-79	1	O-Ring
3	98-4725	4	Hose-HYD	10:2	237-21	1	O-Ring
4	3230-3	4	Screw-CARR	11	108-4714	1	Orifice-Port Insert, One Way
5	2412-137	4	Clamp-R, Double	12	112-2609	6	Pin-Pivot
6	98-4726	1	Hose-HYD	13	302-5	6	Fitting-Grease
7	98-4727	1	Hose-HYD	14	99-5105	6	Screw-Shoulder
8	340-151	2	Fitting-Tee	15	3296-29	4	Nut-Lock, NI
8:1	237-21	2	O-Ring	16	3256-23	4	Washer-Plain
9	340-3	2	Fitting-Straight	17	3334-945	1	Tie-Cable

Hydraulic Cylinder Assembly No. 139-7706

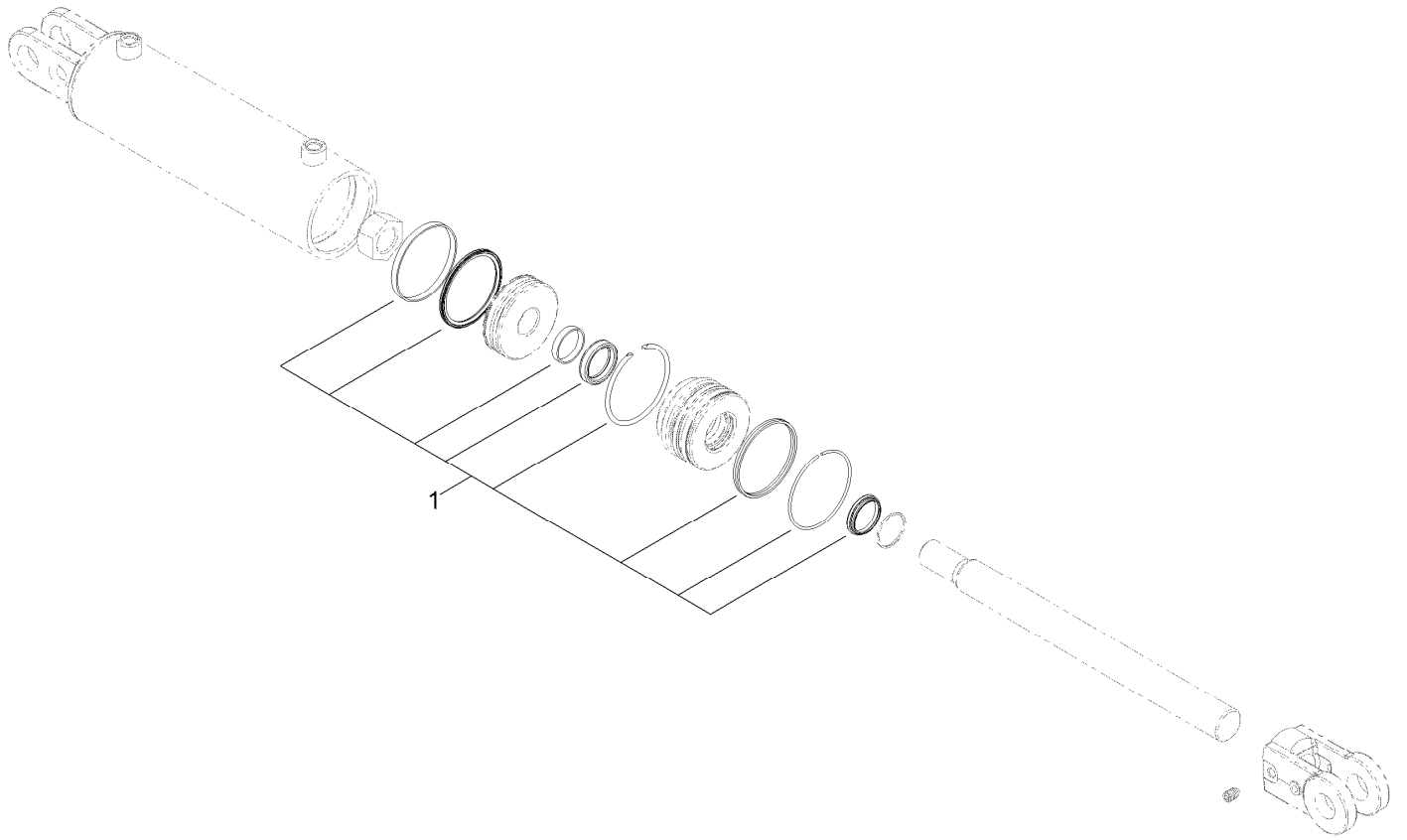

Hydraulic Cylinder Assembly No. 139-7706 (continued)

<i>Ref.</i>	<i>Part Number</i>	<i>Qty.</i>	<i>Description</i>
1	139-7713	1	Kit-Seal, Hydraulic CYL

Attachments and Accessories

For 22318 323 Compact Tool Carrier

Product Name	Model/Part
Tire Chain Kit	100-4140
Helmet-Face Shield	100-4143
Narrow Tire ASM	104-0572
Tube-Tire (18 x 8.50-10)	105-4070
Rubber Foot Mat.....	105-5805
Tube-Tire (18 X 8.50-8).....	106396
Tube-Tire	107-2491
Spare Tire Kit Assembly	144-0105
Tire And Wheel ASM, RH	144-2574
Tire And Wheel ASM, LH	144-2575
Light Kit ASM	144-7101
Tire And Wheel ASM	147-6040
Adjustable Forks.....	22341
CE Conversion Kit	22366
4 Cubic Foot Standard Bucket	22409
Loose Materials Bucket	22410
48in Hydraulic Blade.....	22414
Bore Drive Head	22420
Rod and Reamer	22421
Multi-Purpose Tool.....	22423
Direct Drive Power Box Rake	22426
Stump Grinder	22429
Tree Forks	22438
Cement Bowl	22442
40in Tiller	22445
High-Torque Trencher Head	22473
High-Speed Trencher Head	22474
Narrow Bucket.....	22520
Grapple Rake	22577
Auger Head	22805
Universal Swivel Auger Head	22806
18in Auger Bit	22814
24in Auger Bit	22815
12in Auger Bit Extension	22818
24in Auger Bit Extension	22819
6in Full-Flight Auger Bit	22820
9in Full-Flight Auger Bit	22821
12in Full-Flight Auger Bit.....	22822
15in Full-Flight Auger Bit.....	22823
Vibratory Plow	22911
Soil Cultivator	23102
Concrete Breaker	23135
Backhoe.....	23163
Leveler.....	23165
Tube	232-37
Spark Arrestor	98-9099

Attachments and Accessories (continued)

Hydraulic Relief Valve Kit..... 99-4360

For 22318 323 Compact Tool Carrier

Product Name	Model/Part
Tire Chain Kit	100-4140
Helmet-Face Shield	100-4143
Narrow Tire ASM	104-0572
Tube-Tire (18 x 8.50-10)	105-4070
Rubber Foot Mat.....	105-5805
Tube-Tire	107-2491
Premium Engine Oil 10w30 (55 Gallon Drum)	121-6392
Premium Engine Oil 10w30 (5 Gallon Pail)	121-6393
Premium Engine Oil 15w40 (55 Gallon Drum)	121-6394
Premium Engine Oil 15w40 (5 Gallon Pail)	121-6395
PX Hydraulic Fluid (5 Gal)	133-8086
PX Hydraulic Fluid (55 Gal).....	133-8087
Oil-30/10W-30 Synthetic (Quart).....	138-6053
PX Hydraulic Fluid-4 Pack (Gallon).....	138-9460
Spare Tire Kit Assembly	144-0105
Tire And Wheel ASM, RH	144-2574
Tire And Wheel ASM, LH	144-2575
Light Kit ASM	144-7101
Tire And Wheel ASM	147-6040
Adjustable Forks	22341
CE Conversion Kit	22366
4 Cubic Foot Standard Bucket	22409
Loose Materials Bucket	22410
48in Hydraulic Blade	22414
Bore Drive Head	22420
Rod and Reamer	22421
Multi-Purpose Tool	22423
Direct Drive Power Box Rake	22426
Stump Grinder	22429
Tree Forks	22438
Cement Bowl	22442
40in Tiller	22445
High-Torque Trencher Head	22473
High-Speed Trencher Head	22474
4-in-1 Bucket	22478
Narrow Bucket	22520
Grapple Rake	22577
Floor Scraper.....	22673
Auger Head	22805
Universal Swivel Auger Head	22806
18in Auger Bit	22814
24in Auger Bit	22815
12in Auger Bit Extension	22818
24in Auger Bit Extension	22819

Attachments and Accessories (continued)

6in Full-Flight Auger Bit	22820
9in Full-Flight Auger Bit	22821
12in Full-Flight Auger Bit.....	22822
15in Full-Flight Auger Bit.....	22823
Vibratory Plow	22911
Concrete Breaker	23135
Leveler.....	23165
30in Standard Bucket	23174
30in Pallet Fork.....	23175
30in Grapple	23176
Tube	232-37
10W30 4-Cycle Engine Oil (32oz Bottle).....	38280
Spark Arrestor	98-9099
Hydraulic Relief Valve Kit.....	99-4360

Notes:

Notes:

Notes:



Count on it.