



Count on it.

Parts Catalog

Grandstand® 36in HDM

Model No. 74535—Serial No. 40000000 and Up



Ordering Replacement Parts

To order replacement parts, please supply the part number, the quantity, and the description of each part desired.

Understanding Reference Numbers

Each identified part in an illustration has a reference number. The reference number for a part also appears in the parts list, along with other information about the part.

This catalog uses two special reference number formats, one to indicate parts in a service assembly and another to indicate the quantity of a given part in an illustration.

Service Assembly Reference Numbers

Parts in service assemblies have reference numbers in the form a:b. The a represents the reference number of the entire service assembly and the b represents a sequential number unique to each part within the service assembly.

For example, a wheel assembly might be identified by reference number 6, the tire by 6:1, the valve by 6:2, and the wheel by 6:3. When you order the assembly identified by reference number 6, you receive all parts identified by reference numbers 6:1, 6:2, and 6:3. However, you may also order any part individually. Reference numbers of this type appear in illustration and in parts lists.

Reference Numbers Indicating Quantity

In an illustration, if a reference number indicates more than one part, the reference number has the form nX y. The n represents the quantity of the part, the X is the multiplication symbol, and the y represents the reference number.

For example, in an illustration, the reference number 2X 37 means that two of the parts identified by reference number 37 are indicated.

Contents

Deck Lift Assembly	4
Height-of-Cut Lever No. 142-2579	6
Lift Rod Assembly No. 142-2581	8
Frame Assembly	10
Park Brake Assembly	12
Platform Assembly	14
Hydraulic Assembly	16
Idler Arm Assembly No. 135-1270	18
Engine Assembly	20
Motion Control Assembly	22
Left Motion Control Assembly No. 135-1304	24
Right Motion Control Assembly No. 135-1305	26
Fuel Assembly	28
Fuel Line and Valve Assembly No. 142-3596	30
Electrical Assembly	32
Harness Assembly No. 142-2926	34
Guarding Assembly	36
36 Inch Deck Assembly	38
Deck Decal Assembly	40
Idler Arm Assembly No. 135-1679	42
Rubber Deflector Assembly No. 135-2160	44
Drive Wheel Assembly	46
Caster Wheel Assembly	48
Attachments and Accessories	50

Deck Lift Assembly

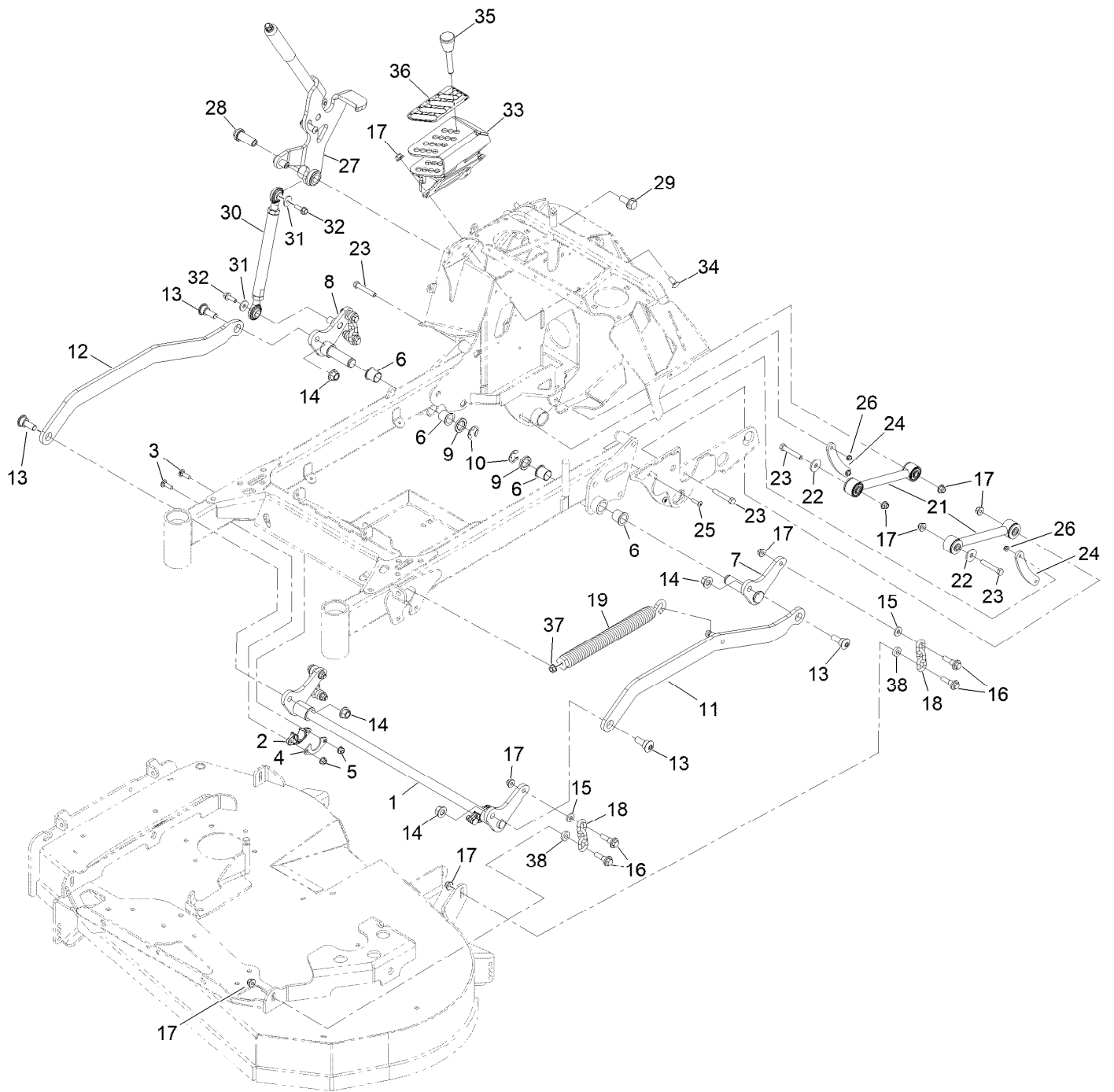

Deck Lift Assembly (continued)

<i>Ref.</i>	<i>Part Number</i>	<i>Qty.</i>	<i>Description</i>	<i>Ref.</i>	<i>Part Number</i>	<i>Qty.</i>	<i>Description</i>
1	142-2566-03	1	Weld, HOC Lift Shaft	21	142-2588	2	ASM, Strut W/ Bushings
2	115-5065	2	Bushing-Flange	22	2844	2	Washer
3	3230-2	4	Bolt-CARR	23	104-3396	4	Screw-HH
4	116-2887	2	Gusset-Lift, Deck	24	142-2772	2	Strip, Rub
5	104-8300	4	Nut-HF, NI	25	32105-32	4	Screw-TTH
6	135-1248	4	Bushing, Igus	26	104-7201	4	Nut-HF, NI
7	142-4524-03	1	Weld, Bellcrank, Lt Rr	27	142-2579	1	ASM, HOC Lever
8	142-2570-03	1	Weld, Bellcrank, Rt Rr	28	142-2181	1	Pivot, HOC Lever
9	142-3444	2	Spacer, HOC Pivot	29	3234-38	1	Screw-HHF
10	32151-103	2	Ring-Retaining, EXT	30	142-2581	1	ASM, Lift Rod
11	142-4521-03	1	Weld, Lift Strap, Lt	31	1-603716	2	Washer-Friction
12	142-4522-03	1	Strap, Lift Rt	32	115-5142	2	Screw-HHF
13	135-1259	4	Bolt, Shoulder	33	146-3498-03	1	Weld, HOC Index
14	99-5107	4	Nut-Lock	34	3231-27	3	Screw-CARR
15	43-0940	4	Spacer	35	126-5401	1	Pin-HOC
16	130-0742	8	Bolt-Shoulder	36	142-3087	1	Decal-Height Of Cut
17	104-8301	15	Nut-HF, NI	37	3290-357	1	Nut-HSF
18	103-9859	4	Chain-Decklift	38	5-0652	4	Spacer
19	116-0886	1	Spring-Extension				

Height-of-Cut Lever No. 142-2579

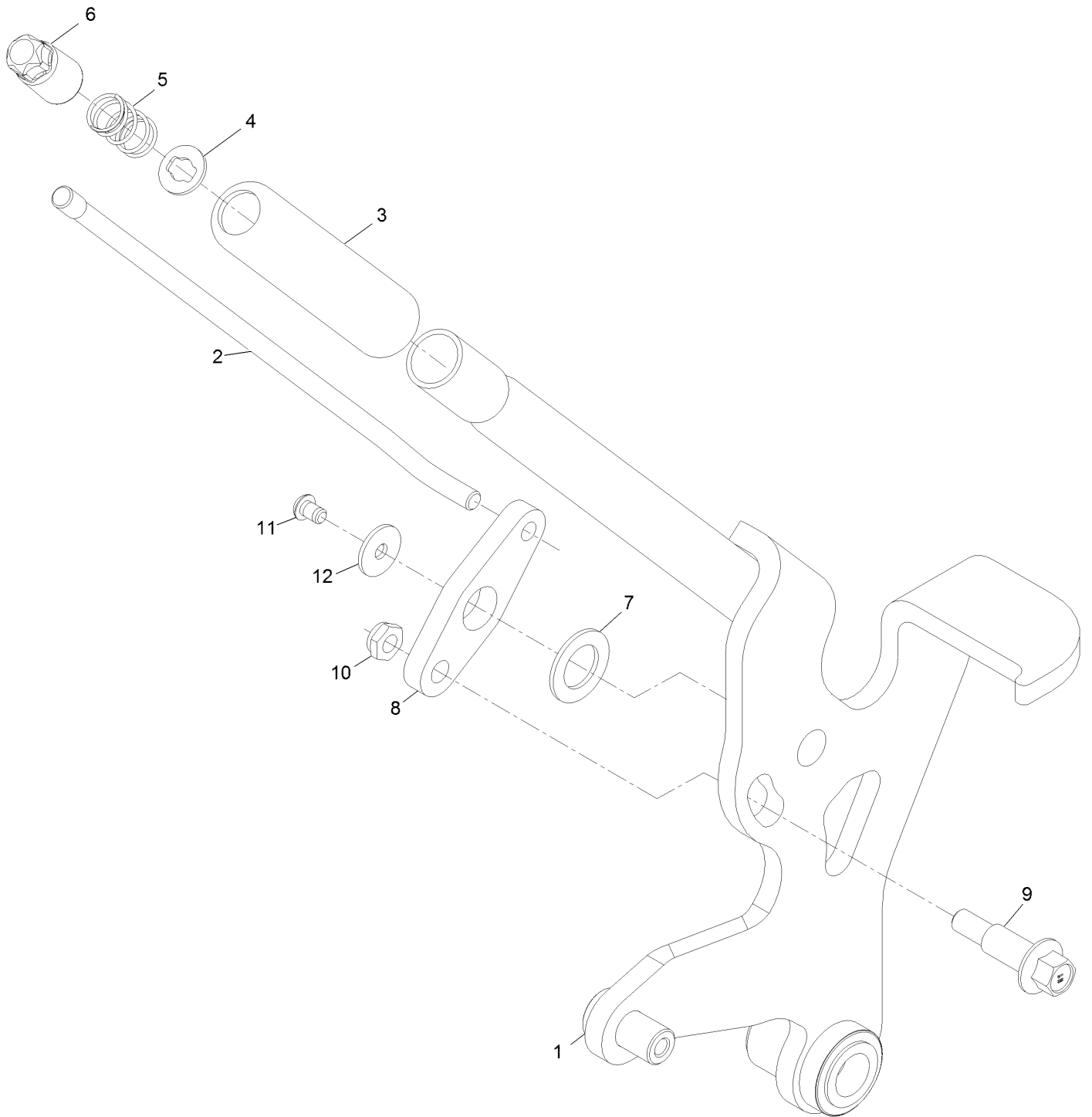

Height-of-Cut Lever No. 142-2579 (continued)

<i>Ref.</i>	<i>Part Number</i>	<i>Qty.</i>	<i>Description</i>
1	142-2577	1	ASM, Lever W/ Bushings
2	142-3358	1	Linkage, HOC Lever
3	115-3592	1	Grip
4	114-1207	1	Washer-Special
5	114-8187	1	Spring-Compression
6	135-7809	1	Button, Push

<i>Ref.</i>	<i>Part Number</i>	<i>Qty.</i>	<i>Description</i>
7	126-7888	1	Washer-Nylon
8	142-2578	1	Arm, Transport
9	142-4197	1	Screw-Bh
10	3296-59	1	Nut-Nyloc 3/8-16 Thin
11	142-2216	1	Screw-Bht
12	3256-67	1	Washer

Lift Rod Assembly No. 142-2581

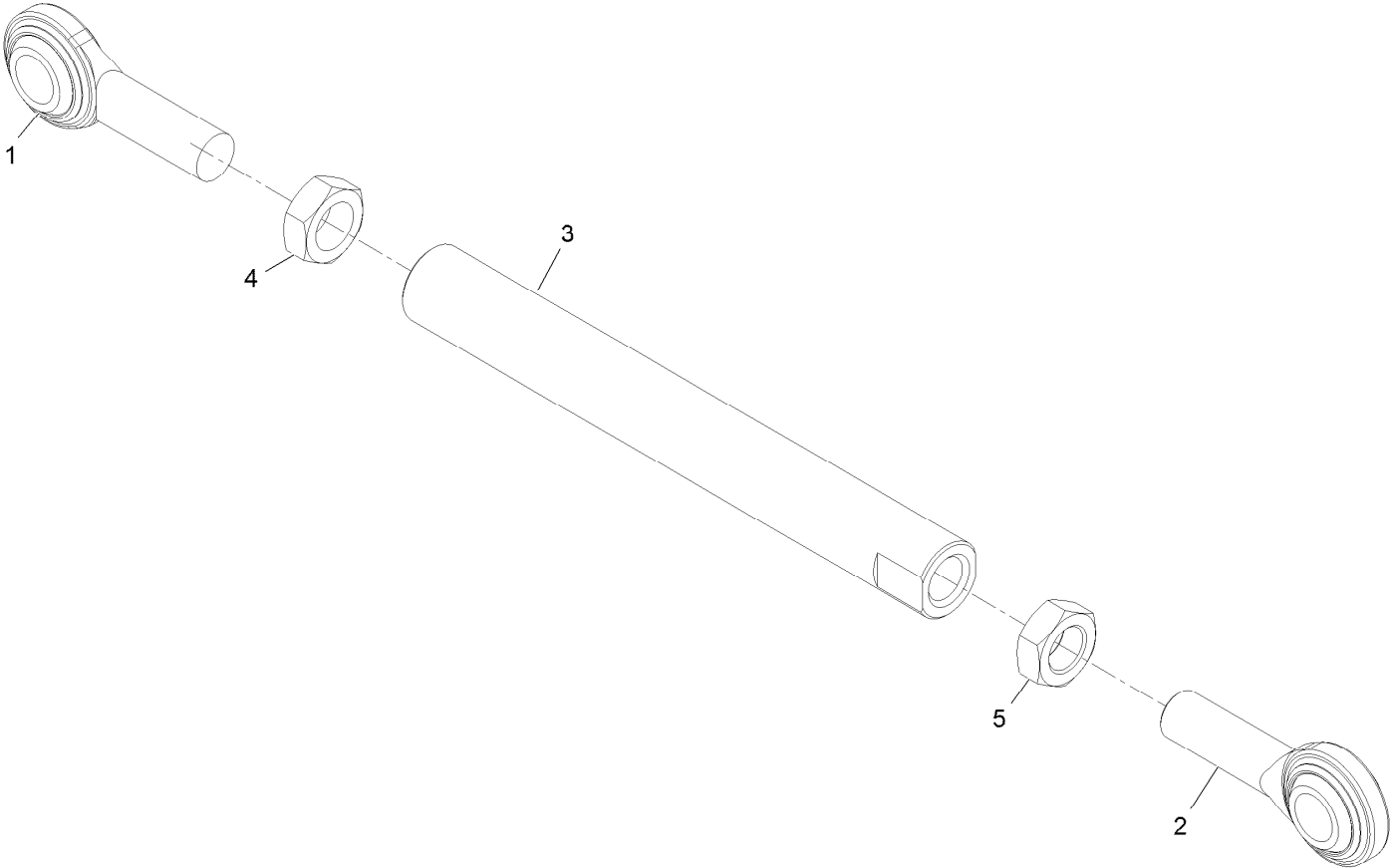

Lift Rod Assembly No. 142-2581 (continued)

<i>Ref.</i>	<i>Part Number</i>	<i>Qty.</i>	<i>Description</i>
1	1-633029	1	Balljoint
2	117-5291	1	Balljoint-Spherical
3	142-2580	1	Rod, Lift

<i>Ref.</i>	<i>Part Number</i>	<i>Qty.</i>	<i>Description</i>
4	3220-6	1	Nut-Jam
5	117-5293	1	Nut-Jam

Frame Assembly

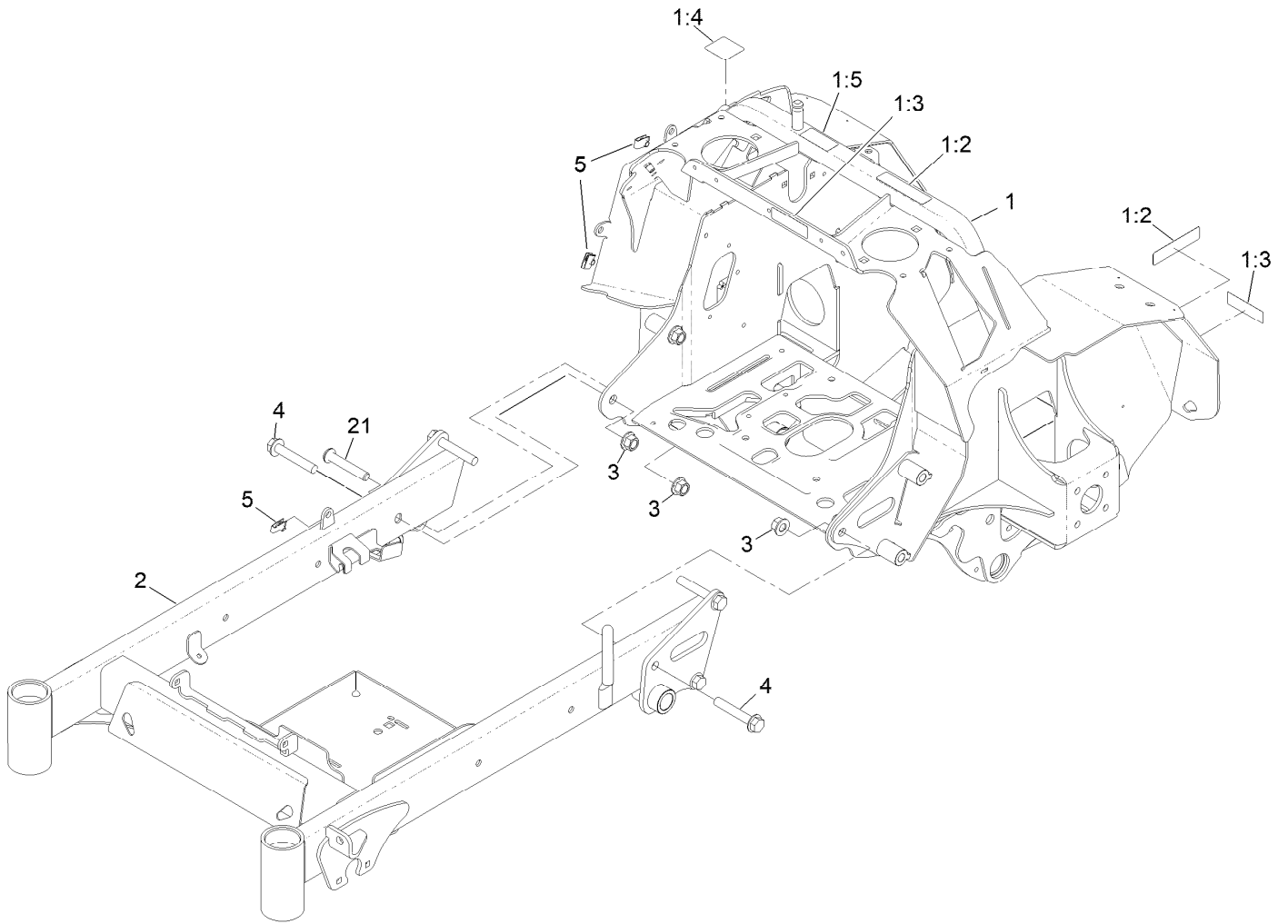

Frame Assembly (continued)

<i>Ref.</i>	<i>Part Number</i>	<i>Qty.</i>	<i>Description</i>	<i>Ref.</i>	<i>Part Number</i>	<i>Qty.</i>	<i>Description</i>
1	146-2773	1	ASM, Rear Frame W/ Decals	2	146-2766-01	1	Weld, Front Frame, 32-36
1:2	98-1977	2	Decal-Warning	3	99-5107	6	Nut-Lock
1:3	116-8559	2	Decal, Cover Missing	4	3234-40	5	Screw-HF
1:4	116-5988	1	Decal-Park Brake, CE	5	107069	3	Clip
1:5	135-2267	1	Decal-Belt Routing HYD	21	142-3783	1	Screw, HSBH

Park Brake Assembly

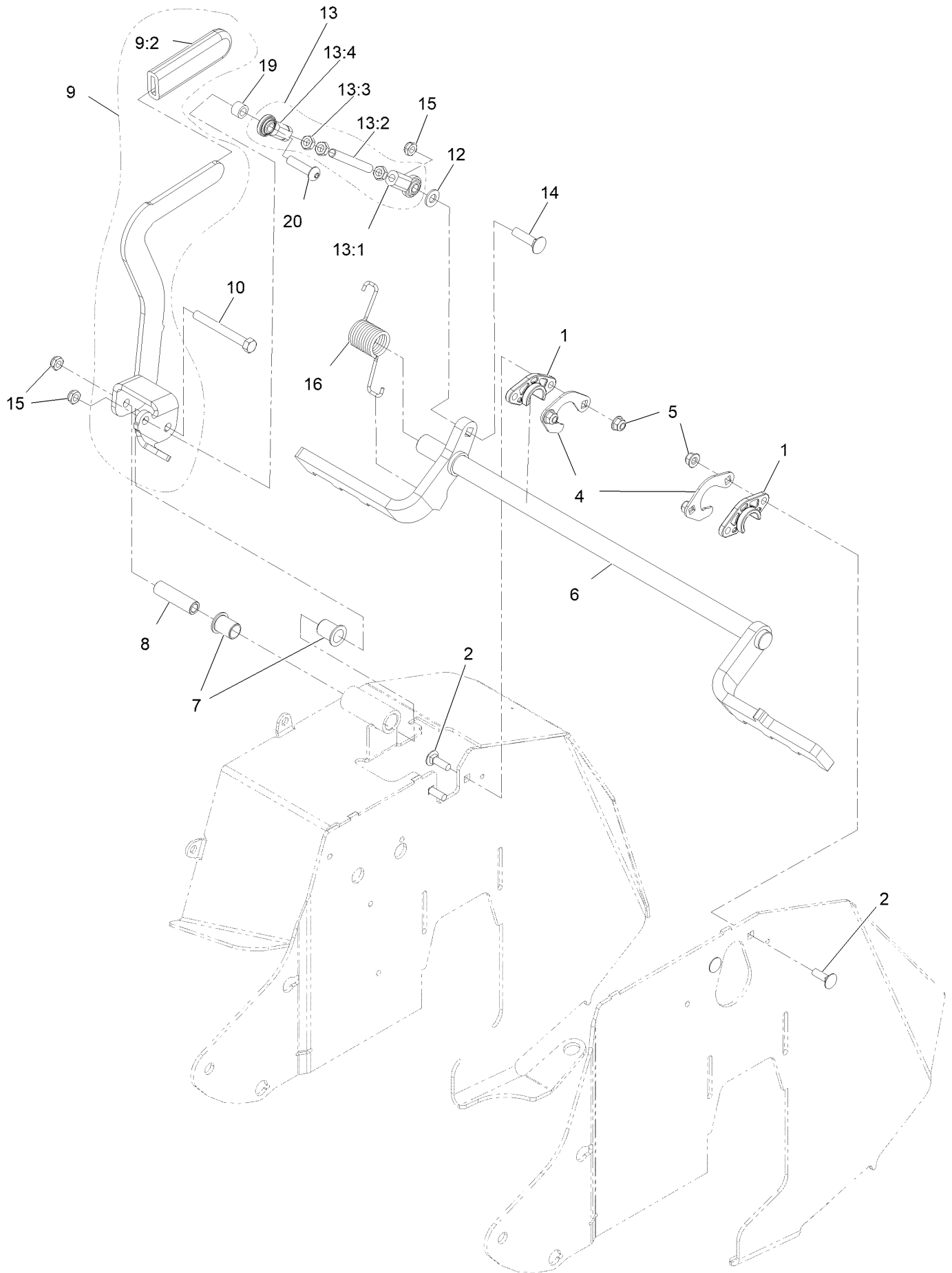

Park Brake Assembly (continued)

<i>Ref.</i>	<i>Part Number</i>	<i>Qty.</i>	<i>Description</i>	<i>Ref.</i>	<i>Part Number</i>	<i>Qty.</i>	<i>Description</i>
1	115-5065	2	Bushing-Flange	13	142-2562	1	ASM, Brake Link
2	3230-2	4	Bolt-Carriage 5/16-18 X 1	13:1	103-0608	1	Balljoint
4	135-7867	2	Support, Bearing	13:2	142-4034	1	Linkage, Brake
5	104-8300	4	Nut-Nyloc 5/16-18 Flg	13:3	3220-3	3	Nut-Jam 3/8-24
6	135-1950-03	1	Wld-Brake Shaft 32/36	13:4	103-1167	1	Joint-Ball End
7	138-2573	2	Bushing-Flange	14	3231-4	1	Bolt-Carriage 3/8-16 X 1 1/2
8	142-2558	1	Spacer, Brake Pivot	15	3296-59	3	Nut-Nyloc 3/8-16 Thin
9	142-2560	1	ASM, Lever W/ Grip	16	108-4052	1	Spring-Torsion
9:2	1-633268	1	Grip-Lever	19	142-4035	1	Spacer
10	112-7161	1	Screw-HH	20	95-3857	1	Screw-HSBH
12	3256-24	1	Washer-3/8 SAE				

Platform Assembly

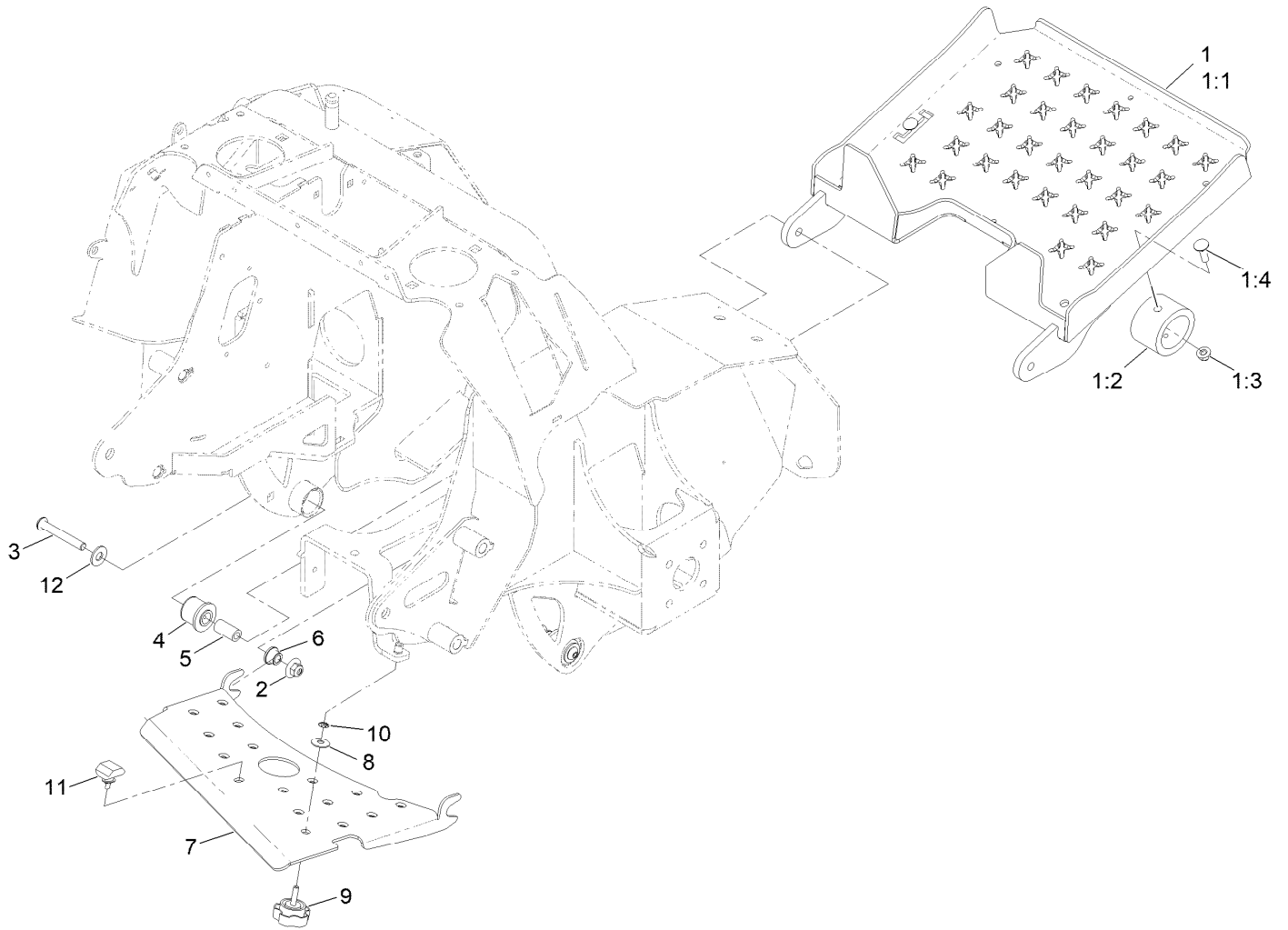

Platform Assembly (continued)

<i>Ref.</i>	<i>Part Number</i>	<i>Qty.</i>	<i>Description</i>	<i>Ref.</i>	<i>Part Number</i>	<i>Qty.</i>	<i>Description</i>
1	142-2710	1	ASM-Platform	5	108-6544	2	Spacer
1:1	142-2470-05	1	Weld-Platform [blk-Txt]	6	109-8788	2	Bushing-Flanged
1:2	135-2548	2	Bumper-Isolator	7	142-2590-03	1	Deflector, Air, 36
1:3	104-8300	2	Nut-HF, NI	8	3290-456	1	Washer-Belleville
1:4	3230-2	2	Bolt-CARR	9	135-7382	1	Knob
2	109-6658	2	Nut-Flange, NI	10	1-803037	1	Nut-Retaining
3	135-7158	2	Screw-HSBH	11	126-9966	1	Bumper-ROPS
4	126-8360	2	Bushing-Rubber, Suspension	12	3256-4	2	Washer-Flat

Hydraulic Assembly

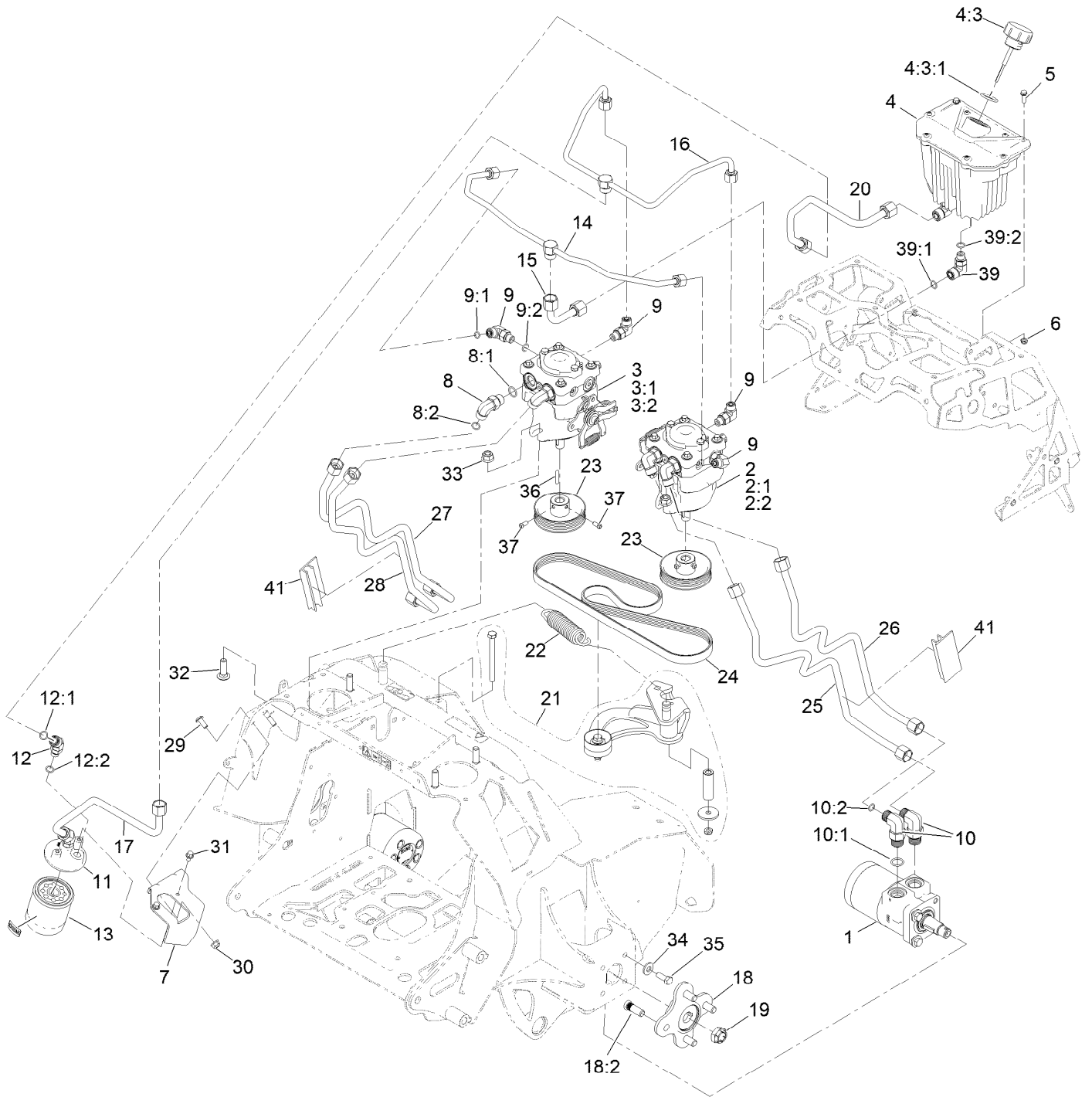

Hydraulic Assembly (continued)

<i>Ref.</i>	<i>Part Number</i>	<i>Qty.</i>	<i>Description</i>	<i>Ref.</i>	<i>Part Number</i>	<i>Qty.</i>	<i>Description</i>
1	135-1274	2	Motor-Wheel	18	135-1621	2	ASM-Hub And Studs
2	135-2212	1	Pump-Hydraulic 10Cc	18:2	116-1696	4	Stud-Wheel
2:1	126-2479	1	Kit, 10Cc/12Cc Pump Kit	19	116-2839	2	Nut-Lock
2:2	105-6184	1	Seal Overhaul Kit	20	142-2593	1	Line, HYD. Supply
3	135-2211	1	Pump-Hydraulic 10Cc	21	135-1270	1	ASM, Idler Arm
3:1	126-2479	1	Kit, 10Cc/12Cc Pump Kit	22	135-1272	1	Spring, Extension
3:2	105-6184	1	Seal Overhaul Kit	23	142-2968	2	Pulley, Pvk5
4	161-6800	1	Hydraulic Reservoir ASM	24	135-1196	1	Belt, Pvk5
4:3	142-2793	1	Cap, Hydraulic	25	142-5632	1	Kit-Ste HYD Line Lt Rear B-A
4:3:1	142-2792	1	O-Ring	26	142-5633	1	Kit-Ste HYD Line Lt Frnt A-B
5	32105-15	2	Screw-HWH	27	142-5634	1	Kit-Ste HYD Line Rt Rear B-B
6	3296-56	2	Nut-Lock, NI	28	142-5635	1	Kit-Ste HYD Line Rt Frnt A-A
7	142-2592-03	1	Mount, Filter	29	126-6268	2	Screw-TTH
8	340-98	4	Fitting-Elbow, 90 DEG	30	104-8300	2	Nut-HF, NI
8:1	237-79	1	O-Ring	31	3234-13	2	Screw-HHF
8:2	237-30	1	O-Ring	32	3232-3	4	Bolt-CARR
9	340-77	4	Fitting-Elbow, 90 DEG	33	114-8417	4	Nut-HF, NI
9:1	237-22	1	O-Ring	34	98-5975	8	Washer-Belleville
9:2	237-42	1	O-Ring	35	323-6	8	Screw-HH
10	340-105	4	Fitting-Elbow, 90 DEG	36	135-7971	2	Key
10:1	237-80	1	O-Ring	37	3241-7	4	Screw-SQH ■
10:2	237-30	1	O-Ring	39	340-99	2	Fitting-HYD, 90 DEG
11	103-2888	1	Head-Filter	39:1	237-30	1	O-Ring
12	340-96	2	Adapter	39:2	237-42	1	O-Ring
12:1	237-30	1	O-Ring	41	142-4399	2	Spacer-Hydraulic Tube
12:2	237-42	1	O-Ring	99	105-6184	1	Seal Overhaul Kit ●
13	114-3494	1	Element-Filter, 25 Micron	99	126-2479	1	Kit, 10Cc/12Cc Pump Kit ●
14	135-7056	1	Line, Hydraulic, Case Tee	99	133-1779	1	Seal Kit ●
15	135-7054	1	Line, Hydraulic, Case				
16	135-7055	1	Line, Hydraulic, Charge Tee				
17	142-2594	1	Line, HYD. Charge				

● Not illustrated

■ Use Pro-Lock, Nut Type (P/N 1-840022, .5ml tube) on threads.

Idler Arm Assembly No. 135-1270

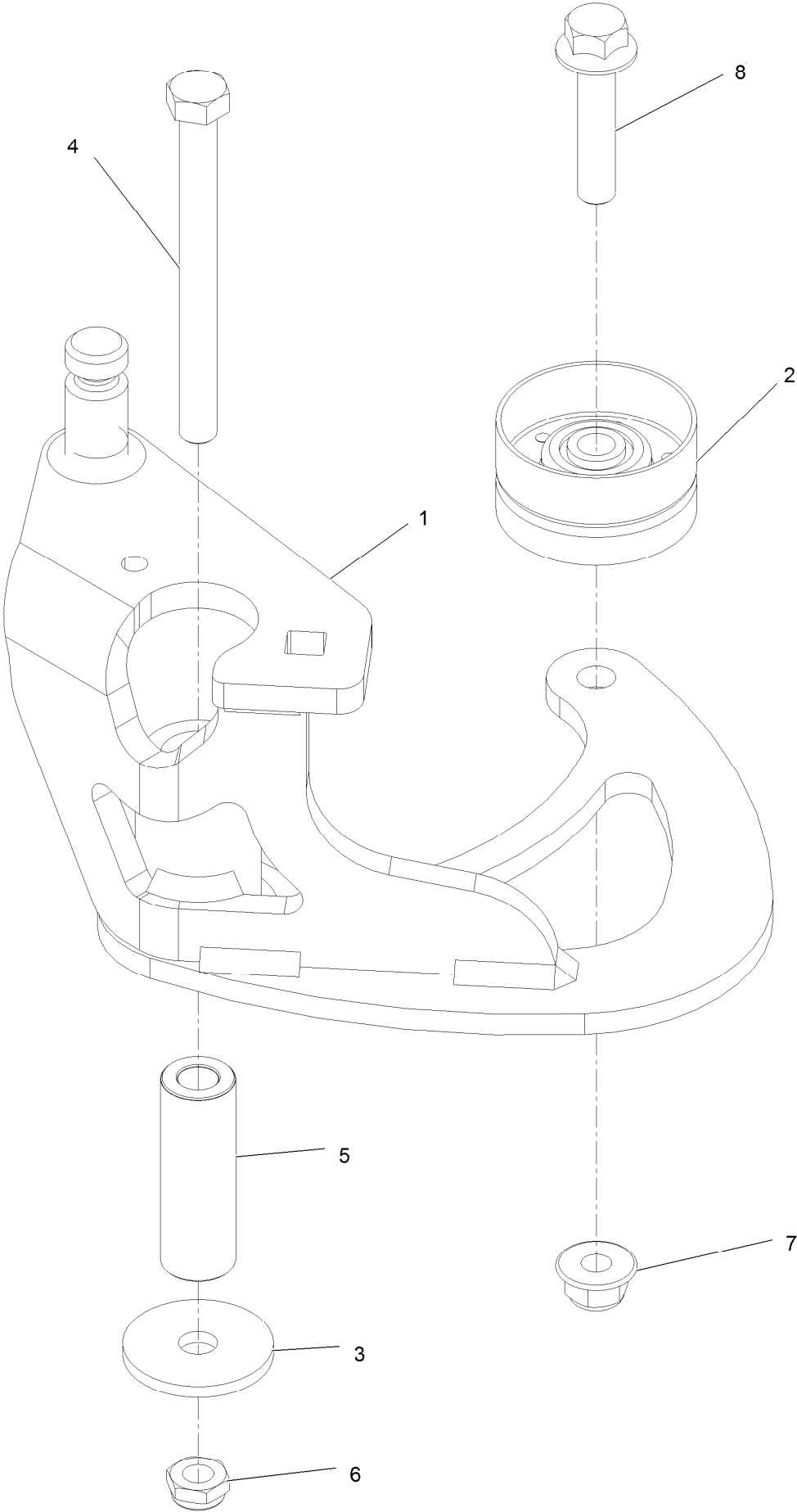

Idler Arm Assembly No. 135-1270 (continued)

<i>Ref.</i>	<i>Part Number</i>	<i>Qty.</i>	<i>Description</i>	<i>Ref.</i>	<i>Part Number</i>	<i>Qty.</i>	<i>Description</i>
1	135-2238	1	ASM, Idler Arm W/ Bushings	5	135-1273	1	Tube, Idler Pivot
2	135-1199	1	Idler, Flat	6	3296-59	1	Nut-Lock, NI
3	1-213069	1	Washer	7	104-8301	1	Nut-HF, NI
4	323-16	1	Screw-HH	8	3234-19	1	Screw-HHF

Engine Assembly

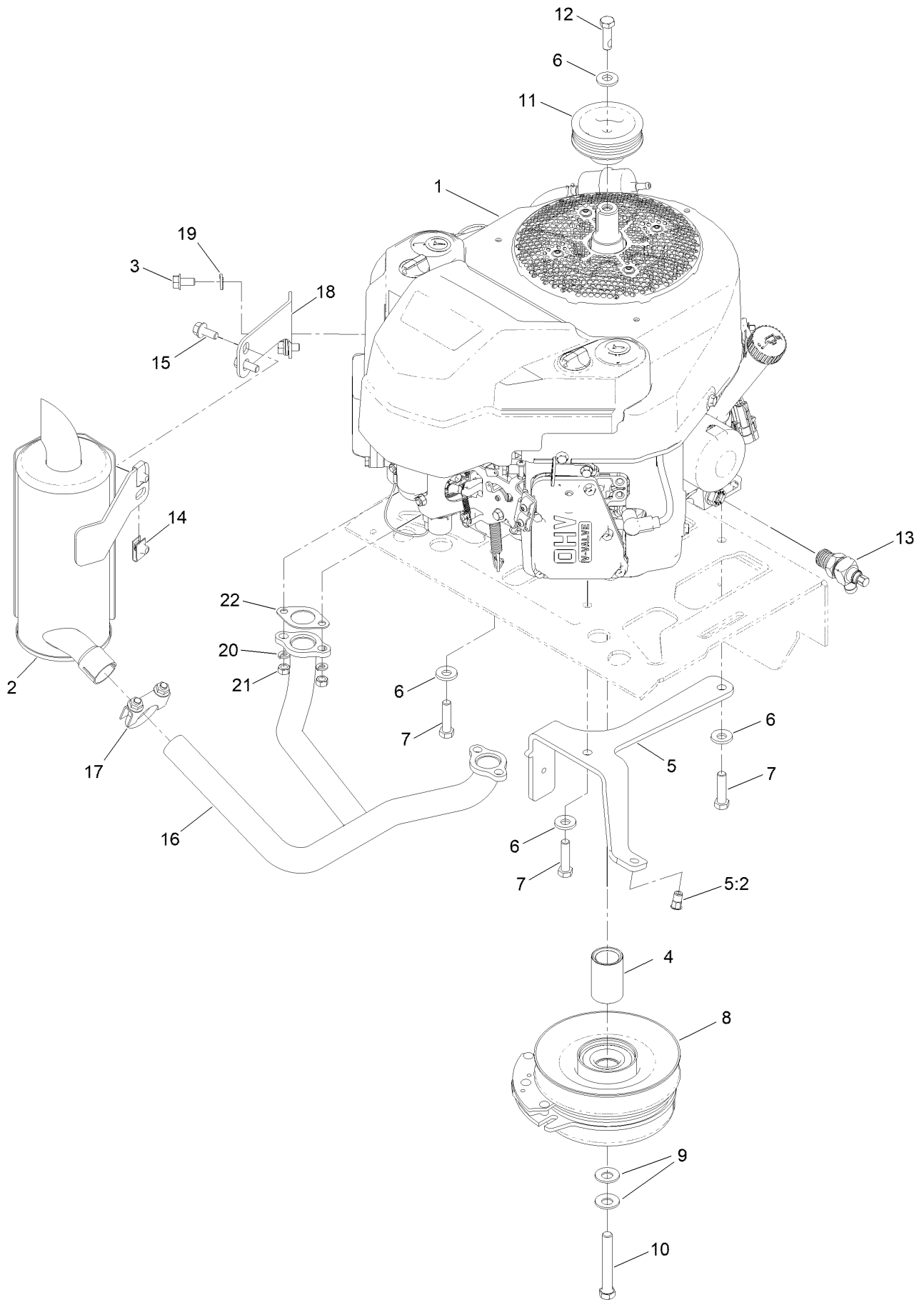

Engine Assembly (continued)

<i>Ref.</i>	<i>Part Number</i>	<i>Qty.</i>	<i>Description</i>	<i>Ref.</i>	<i>Part Number</i>	<i>Qty.</i>	<i>Description</i>
1		1	Engine-Kawasaki Fs600 ▲◆	6	98-5975	5	Washer-Belleville
1:1		1	Kawasaki 49065-7007 Engine Oil Filter ▲◆●	7	323-8	4	Screw-HH
1:2		1	Kawasaki 49019-0031 Fuel Filter ▲◆●	8	142-3586	1	Clutch 105
1:3		1	Kawasaki 92070-7004 Plug-Spark Bpr4ES ▲◆●	9	1-603610	2	Washer-Spring
1:4		1	Kawasaki 11013-7046 Foam Pre-Filter ▲◆●	10	126-7198	1	Screw-HH W/Loctite □
1:5		1	Kawasaki 11013-0752 Air Filter ▲◆●	11	135-1198	1	Pulley, Crank
2	135-5025	1	Muffler-Vertical Ka	12	135-7890	1	Screw-HH, Patch,
3	33104-016	2	Screw-HHF	13	135-2660	1	Drain-Oil Valve ■
4	135-5028	1	Spacer-Clutch	14	94-2413	2	Nut-U
5	135-6711	1	ASM-Clutch Anchor W/Insert	15	3234-5	2	Screw-HHF
5:2	138-2758	1	Nut-Clinch,Hex	16	135-5026	1	Manifold-Vertical Ka Exh
				17	104-4090	1	Clamp-Muffler
				18	135-3828-03	1	Bracket-Muffler Vertical
				19	3253-21	2	Washer-Lock
				20	114-3550	4	Washer-Lock
				21	114-3549	4	Nut
				22	1-653313	2	Gasket-Exhaust

● Not illustrated

▲ Not serviced separately

□ Use Pro-Lock, Nut Type (P/N 1-840022, .5ml tube) on threads.

■ Torque to 23-29 ft-lb

◆ Obtain parts from www.kawpower.com

Motion Control Assembly

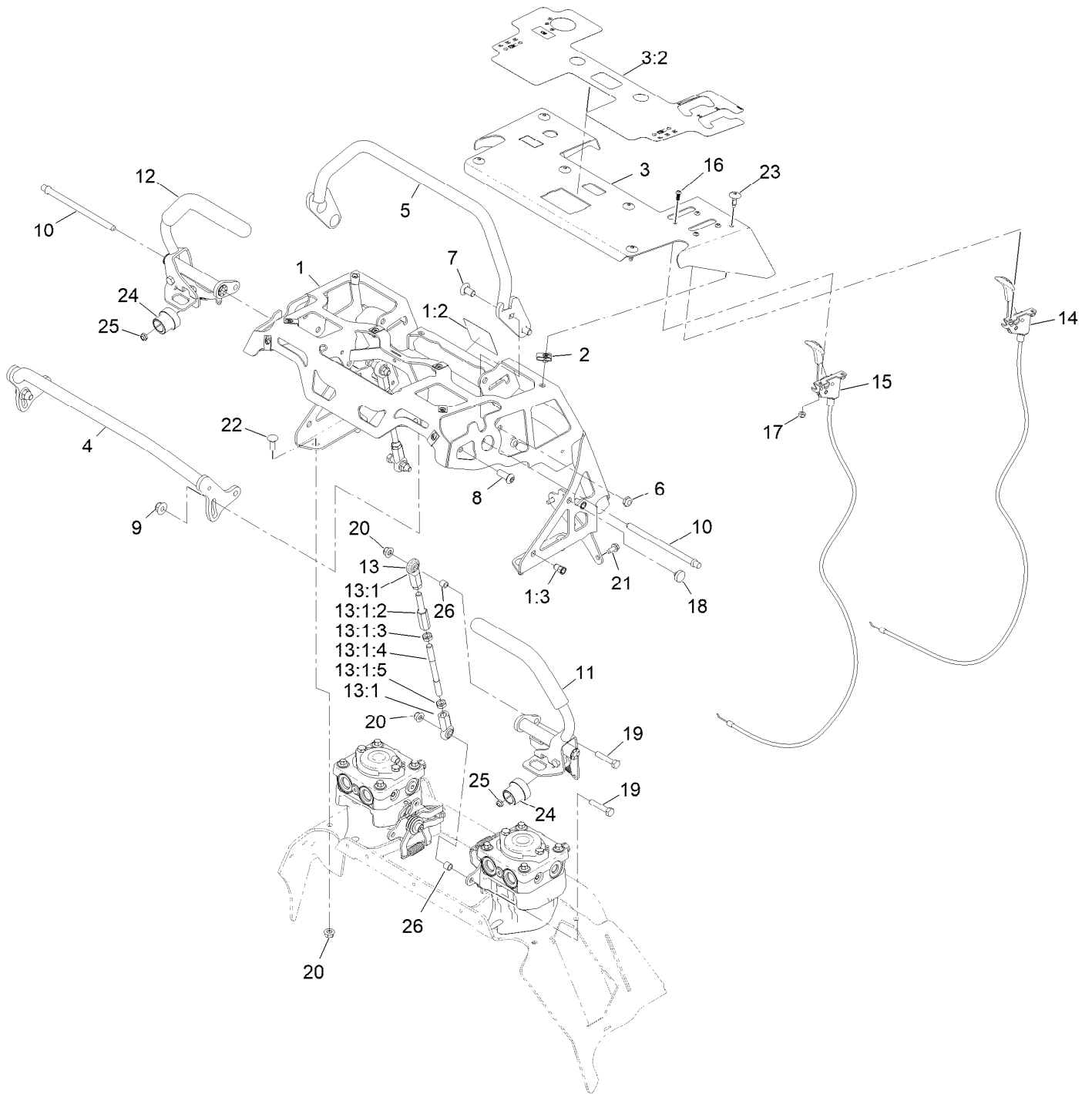

Motion Control Assembly (continued)

<i>Ref.</i>	<i>Part Number</i>	<i>Qty.</i>	<i>Description</i>	<i>Ref.</i>	<i>Part Number</i>	<i>Qty.</i>	<i>Description</i>
1	146-2939	1	ASM-Ctrl Tower	13:1		1	ASM, Motion Control Link ●
1:2	142-3077	1	Decal-HYD Fluid Warn	13:1:2	116-4755	1	Rod-Adjustment
1:3	138-2758	2	Nut-Clinch,Hex	13:1:3	3220-16	1	Nut-Hex Jam, LH
2	107069	8	Clip	13:1:4	135-1291	1	Link, Motion Control
3	146-2936	1	ASM, Control Panel W/ Decals	13:1:5	3220-3	1	Nut-HJ
3:2	135-6773	1	Decal-Control Panel Non-EFI	14	135-2168	1	Control, Choke
4	135-3432-05	1	Weld, Front Ref Bar	15	135-2169	1	Control, Throttle
5	135-3430-05	1	Weld, Rear Ref Bar	16	135-3176	4	Screw, BHCS
6	3296-59	4	Nut-Lock, NI	17	3296-2	4	Nut-Lock, NI
7	3231-21	4	Screw-CARR	18	1-513658	2	Bumper
8	3274-94	2	Screw-HSBH	19	322-8	4	Screw-HH
9	104-8301	2	Nut-HF, NI	20	104-8300	8	Nut-HF, NI
10	135-1277	2	Pin, Pivot	21	32144-10	4	Screw-HWH
11	135-1304	1	ASM, Motion Control, Lt	22	3230-16	4	Screw-CARR
12	135-1305	1	ASM, Motion Control, Rt	23	135-3494	6	Screw, Torx
13	135-7116	2	ASM, Linkage	24	126-1499	2	Cam
				25	3296-56	2	Nut-Lock, NI
				26	1-633545	4	Spacer

● Not serviced separately

Left Motion Control Assembly No. 135-1304

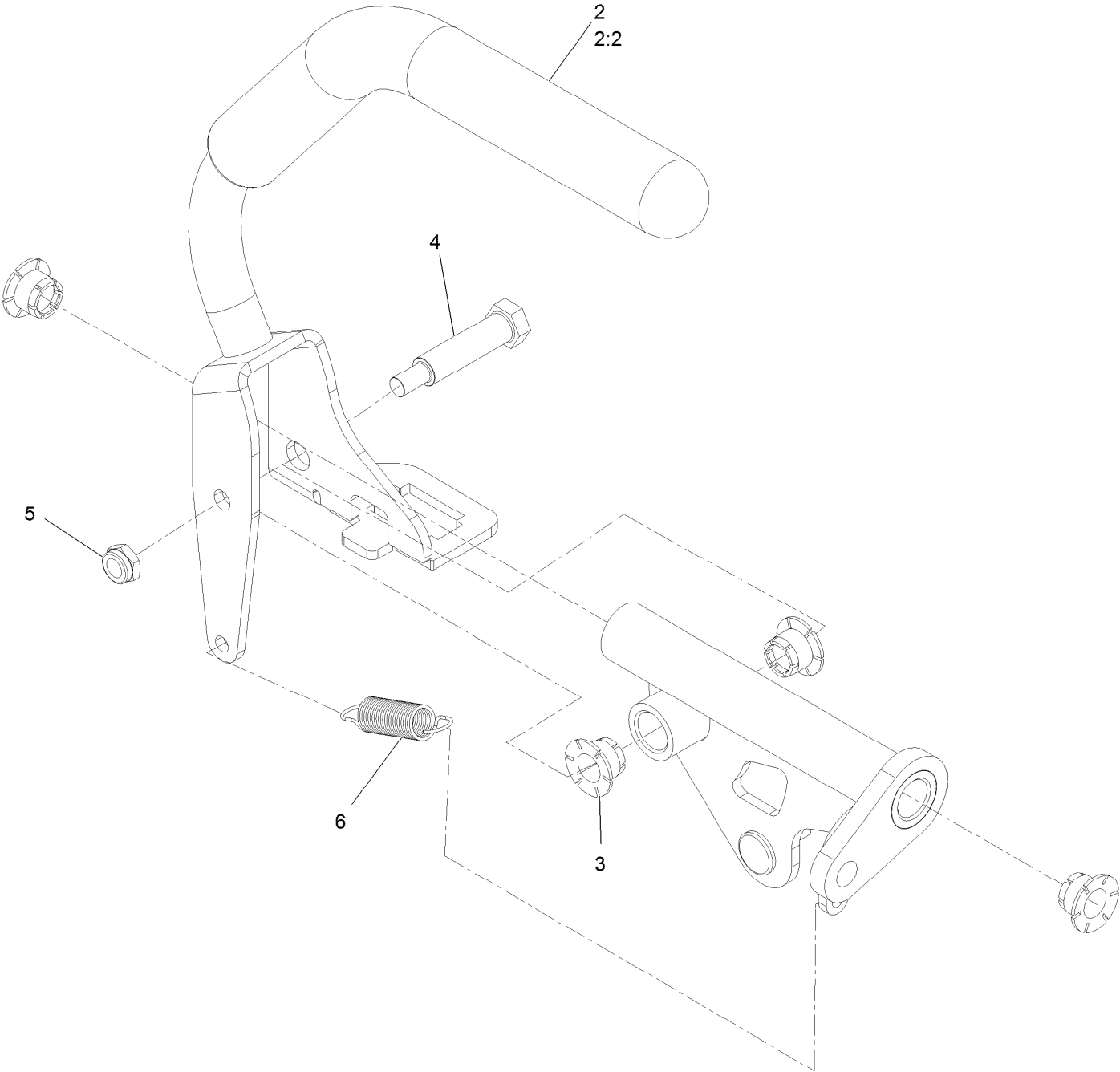

Left Motion Control Assembly No. 135-1304 (continued)

<i>Ref.</i>	<i>Part Number</i>	<i>Qty.</i>	<i>Description</i>	<i>Ref.</i>	<i>Part Number</i>	<i>Qty.</i>	<i>Description</i>
2	135-2546	1	ASM, Lt Control Lever W/ Grip	4	121-1229	1	Bolt-Shoulder
2:2	135-3301	1	Grip, Drive Lever	5	3296-56	1	Nut-Lock, NI
3	135-6412	4	Bearing, Igus	6	114-0249	1	Spring-Extension

Right Motion Control Assembly No. 135-1305

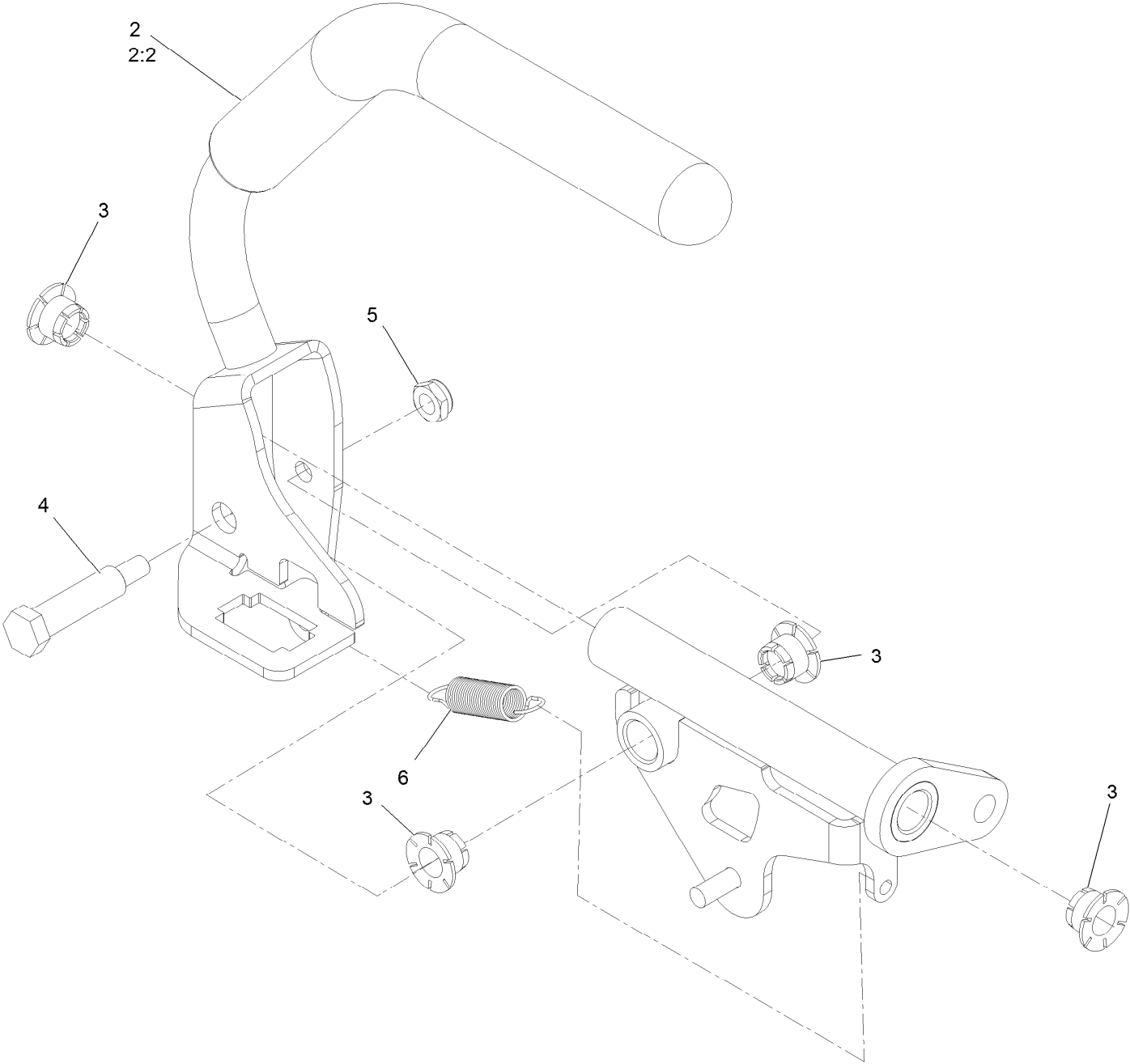

Right Motion Control Assembly No. 135-1305 (continued)

<i>Ref.</i>	<i>Part Number</i>	<i>Qty.</i>	<i>Description</i>	<i>Ref.</i>	<i>Part Number</i>	<i>Qty.</i>	<i>Description</i>
2	135-2547	1	ASM, Rt Control Lever W/ Grip	4	121-1229	1	Bolt-Shoulder
2:2	135-3301	1	Grip, Drive Lever	5	3296-56	1	Nut-Lock, NI
3	135-6412	4	Bearing, Igus	6	114-0249	1	Spring-Extension

Fuel Assembly

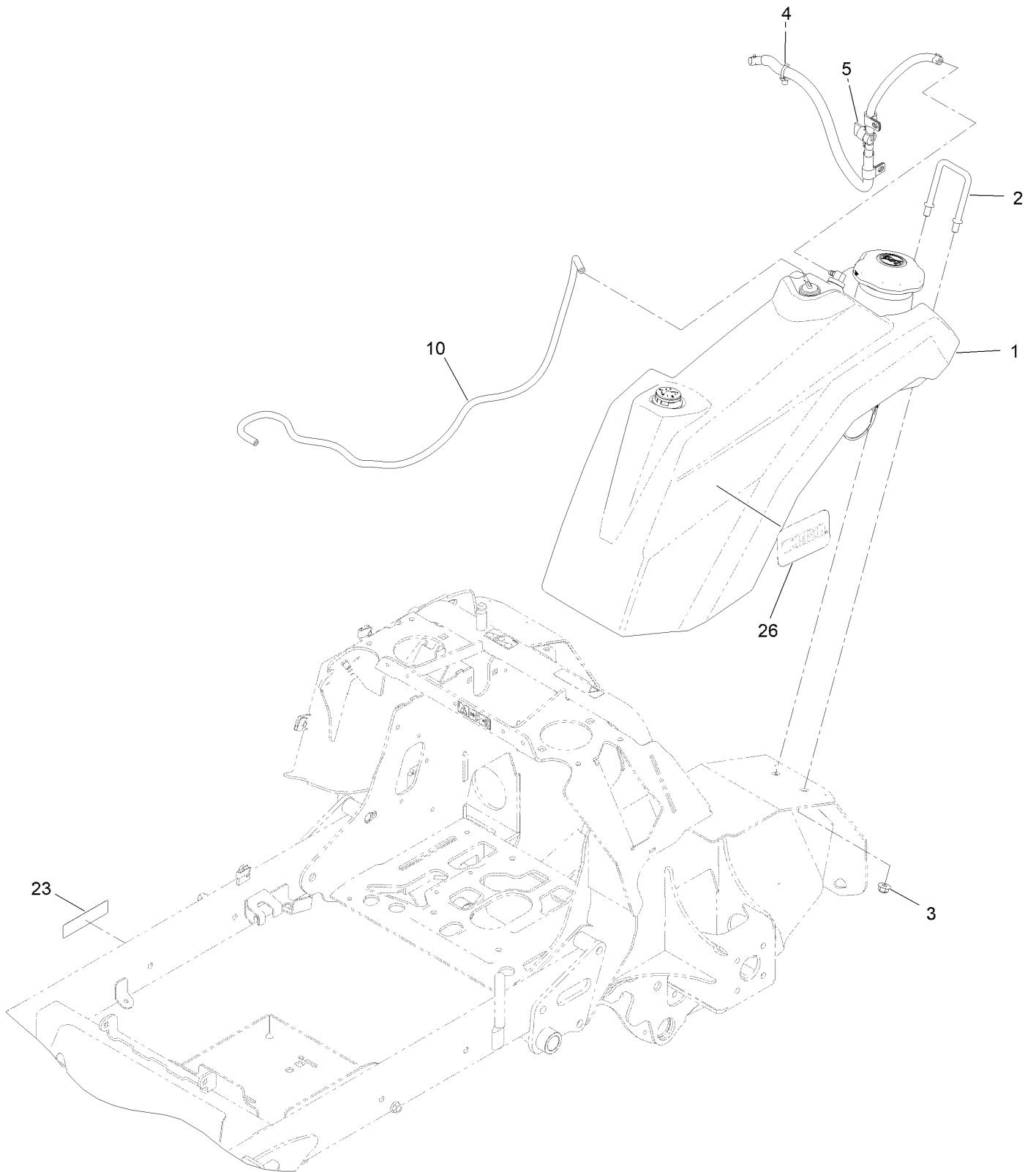

Fuel Assembly (continued)

<i>Ref.</i>	<i>Part Number</i>	<i>Qty.</i>	<i>Description</i>	<i>Ref.</i>	<i>Part Number</i>	<i>Qty.</i>	<i>Description</i>
1	161-6672	1	ASM-Fuel Tank	5	142-3596	1	ASM-Fuel Line & Valve
2	135-1921	1	Clamp, Tank	10	110-3958	1	Hose-Fuel
3	104-8301	2	Nut-HF, NI	23	133-8062	1	Decal-Spark Arrestor
4	32180-030	1	Clip-Tie	26	161-6663	1	Decal-Toro Logo

Fuel Line and Valve Assembly No. 142-3596

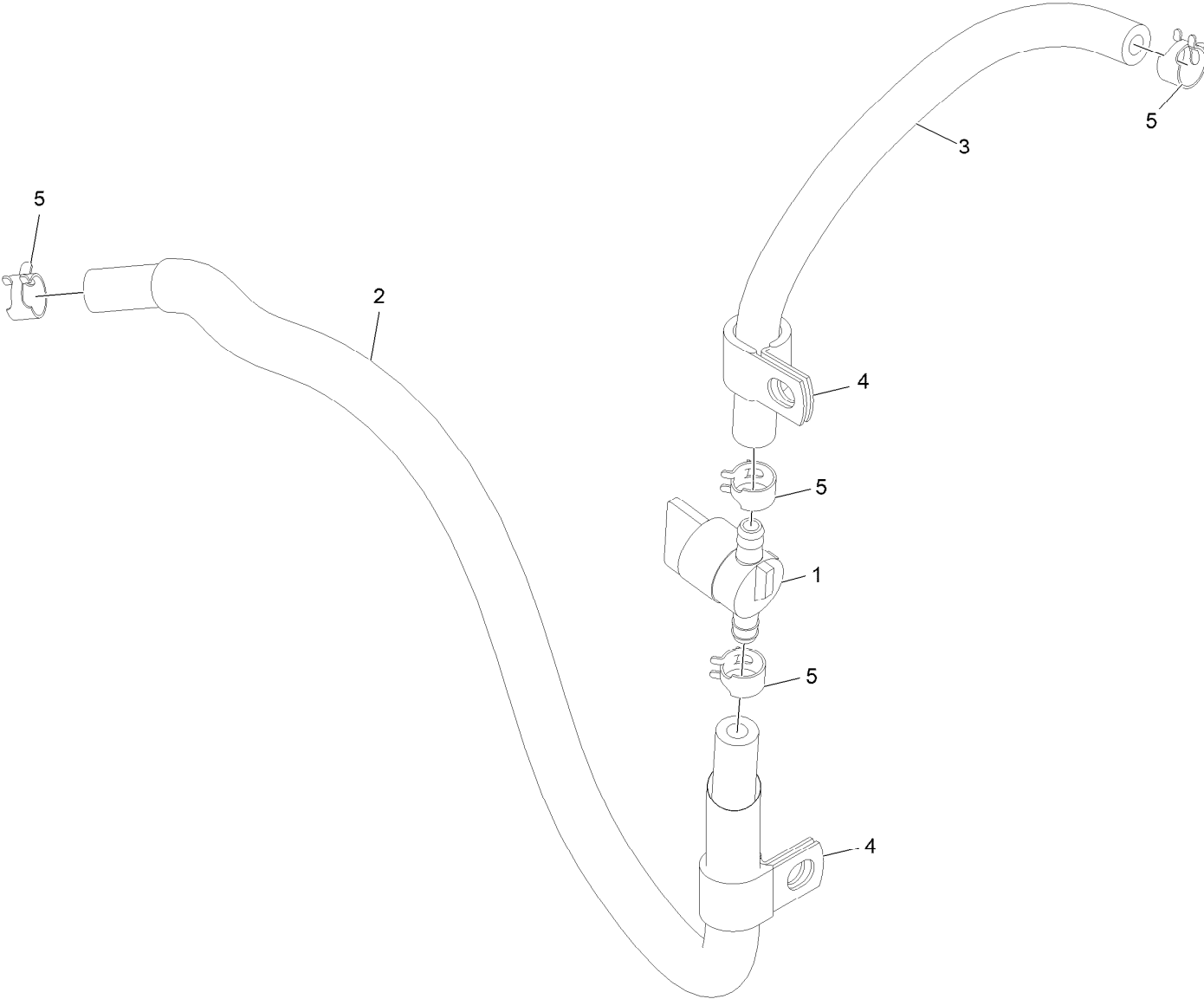

Fuel Line and Valve Assembly No. 142-3596 (continued)

<i>Ref.</i>	<i>Part Number</i>	<i>Qty.</i>	<i>Description</i>	<i>Ref.</i>	<i>Part Number</i>	<i>Qty.</i>	<i>Description</i>
1	1-603770	1	Valve-Fuel	4	92-6064	2	Clamp-R
2	109-0298	1	Line-Fuel	5	2412-98	4	Clamp-Hose
3	109-0293	1	Hose-Fuel				

Electrical Assembly

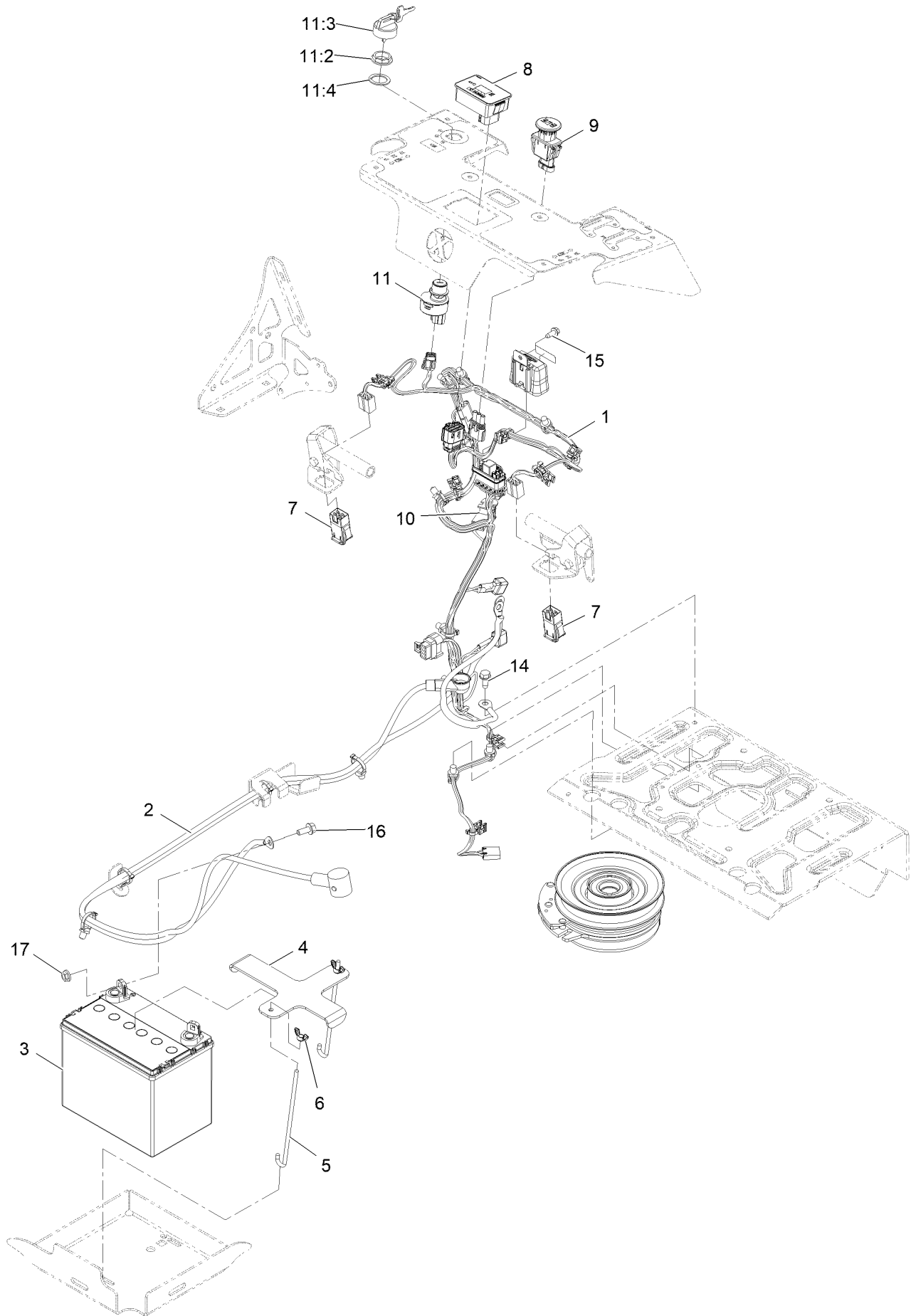

Electrical Assembly (continued)

<i>Ref.</i>	<i>Part Number</i>	<i>Qty.</i>	<i>Description</i>	<i>Ref.</i>	<i>Part Number</i>	<i>Qty.</i>	<i>Description</i>
1	142-2926	1	Harness-Wiring ■	11	126-6285	1	Ignition Switch ASM
2	135-2255	1	Harness-Battery	11:2	108-8660	1	Nut-Mounting
3	99-7421	1	Battery- Wet, 12V, 300 CCA	11:3	106-5270	1	Ignition Key Set
4	135-2056	1	Bracket, Battery Hold Down	11:4	108-8659	1	Washer-Backup
5	1-633651	2	Bolt-Holddown	14	32144-11	1	Screw-HWH 5/16-18 X 3/4 Tf
6	1-543792	2	Wingnut-Nyloc 1/4-20	15	32144-10	1	Screw-HWH 1/4-20 X .62
7	104-3338	2	Switch-Delta	16	3234-5	2	Screw-HH Flg 5/16-18 X 3/4
8	135-7189	1	Module-Hour Meter	17	32128-20	2	Nut-Whizlock 5/16-18 ●
9	126-6187	1	Switch-PTO, Sealed				
10	82-2190	1	Switch				

● Not illustrated

■ Use dielectric grease on all unsealed connectors and terminals only. Do not apply in sealed connectors.

Harness Assembly No. 142-2926

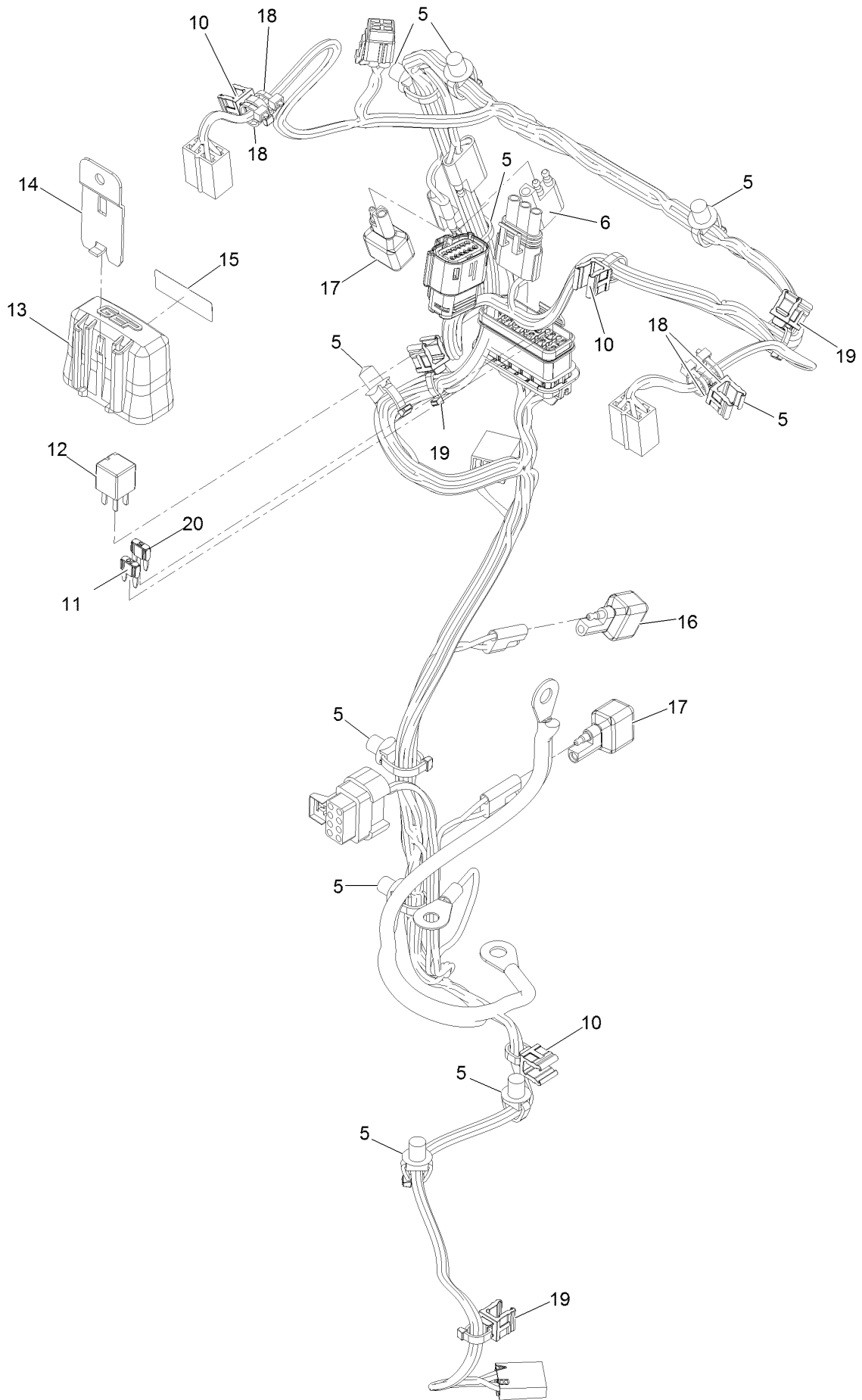

Harness Assembly No. 142-2926 (continued)

<i>Ref.</i>	<i>Part Number</i>	<i>Qty.</i>	<i>Description</i>	<i>Ref.</i>	<i>Part Number</i>	<i>Qty.</i>	<i>Description</i>
5	32180-030	9	Clip-Tie	15	126-7875	1	Decal-Fuse
6	32180-197	1	Cap-Plug	16	103-3895	1	Diode
10	32180-078	4	Clip-Edge	17	100-4918	2	Diode
11	121-8868	1	Fuse-Mini Blade, 20 Amp	18	1-303287	7	Tie-Cable
12	126-3991	1	Relay-Micro	19	32180-082	3	Clip-Edge W/Tie, Perpendicular
13	32180-176	1	Cover-Block, Fuse	20	121-8867	1	Fuse-Mini Blade, 15 Amp
14	32180-177	1	Clip-Mounting				

Guarding Assembly

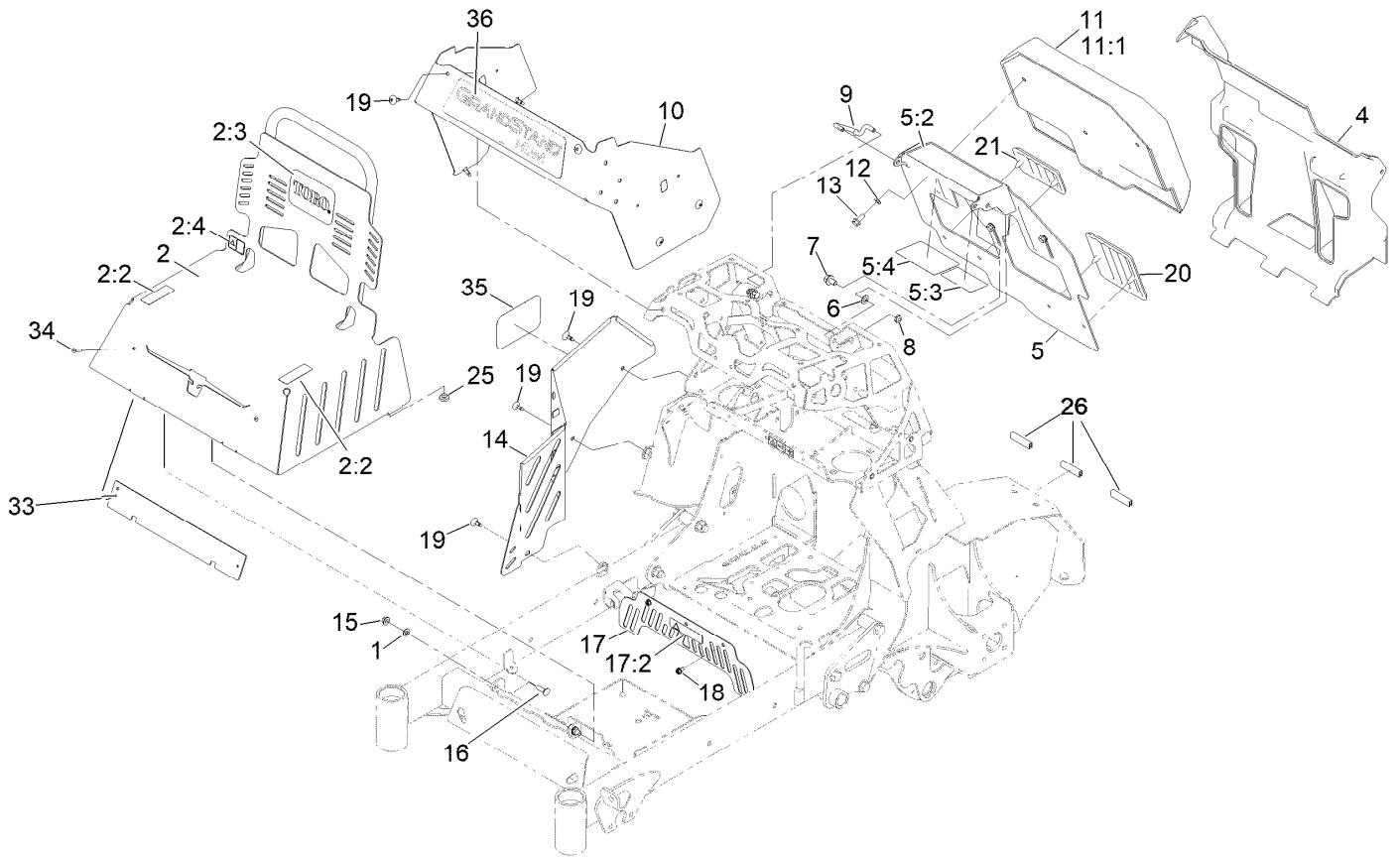

Guarding Assembly (continued)

<i>Ref.</i>	<i>Part Number</i>	<i>Qty.</i>	<i>Description</i>	<i>Ref.</i>	<i>Part Number</i>	<i>Qty.</i>	<i>Description</i>
1	93-6079	2	Spacer-Nylon	12	3290-475	3	Washer-Belleville
2	161-3594	1	Engine Guard W/Decals	13	100-1668	3	Screw-HHF
2:2	136-1672	2	Decal-No Step/Riders	14	146-2749-03	1	Cover Rt Side
2:3	105-8278	1	Decal	15	32128-25	2	Nut-HF
2:4	106-5517	1	Decal-Warning	16	3230-2	2	Bolt-CARR
4	142-3523	1	Cover-Rear Ste	17	135-2204	1	ASM, Belt Guard W/ Decal
5	135-2601	1	ASM, Pad Backing W/ Decals	17:2	98-1977	1	Decal-Warning
5:2	135-2412	1	Decal-Warning	18	32104-17	2	Screw-HWH
5:3	116-8253	1	Decal-Drive Release	19	135-3494	9	Screw, Torx
5:4	135-2563	1	Decal-Service Aid Sm	20	135-5344	1	Pad, Knee, Lt
6	131-8667	2	Washer-Thrust	21	135-5345	1	Pad, Knee, Rt
7	3234-9	2	Screw-HHF	25	1-513658	2	Bumper
8	3296-59	2	Nut-Lock, NI	26	142-4759	3	Strip-Seal 2.13
9	135-1611	1	Rod, Prop	33	161-3528-01	1	Plate-Backer
10	146-2751-01	1	Skin Tower	34	130-8451	2	Rivet-Trifold
11	161-3555	1	Pad-Thigh	35	105-8278	1	Decal
11:1	161-3554	1	Cover Pad	36	161-6662	1	Decal-Gradstand Hdm

36 Inch Deck Assembly

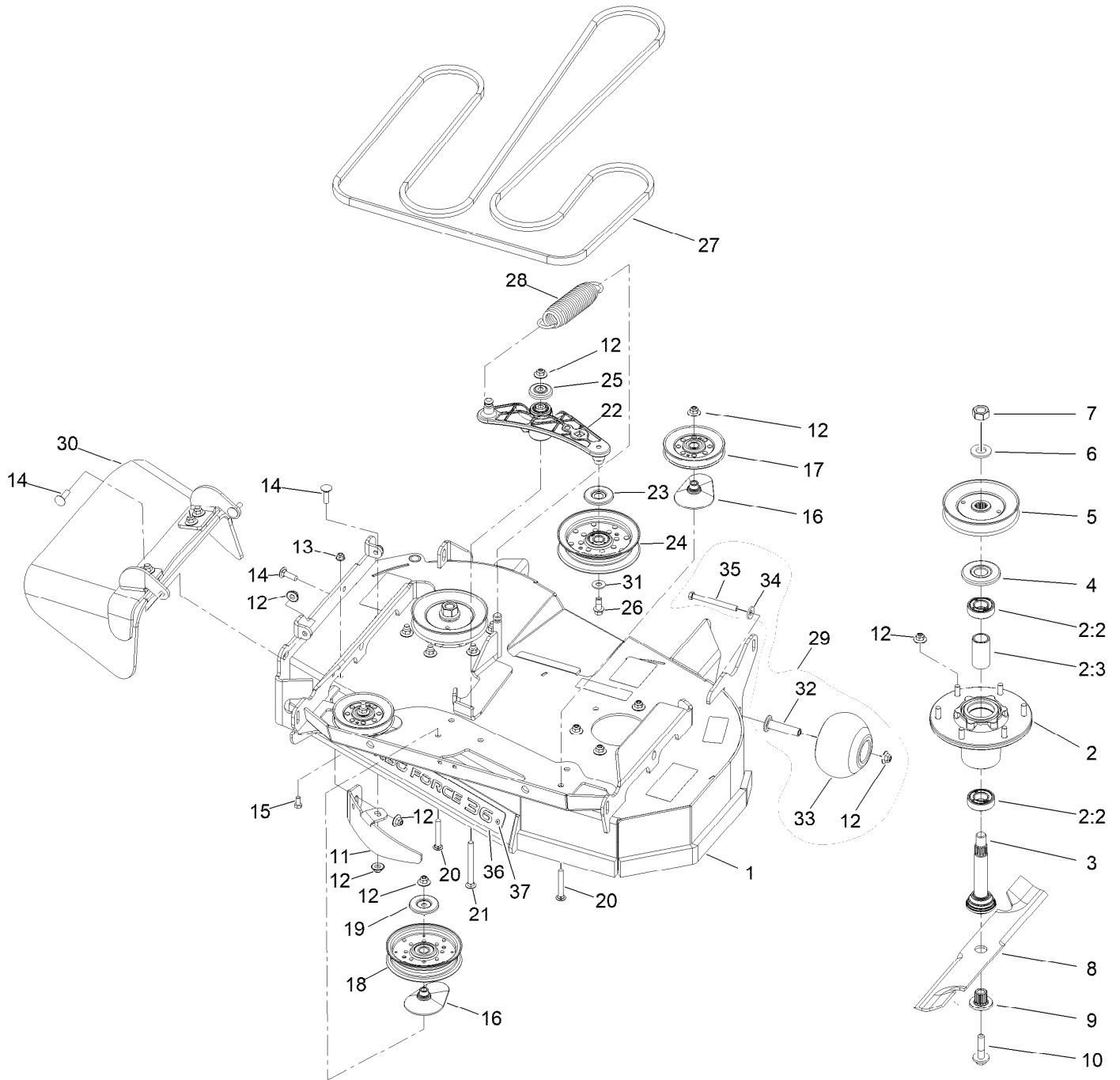

36 Inch Deck Assembly (continued)

<i>Ref.</i>	<i>Part Number</i>	<i>Qty.</i>	<i>Description</i>	<i>Ref.</i>	<i>Part Number</i>	<i>Qty.</i>	<i>Description</i>
1	161-6759	1	ASM-Deck W/Decals	18	126-9187	1	Pulley-Idler, Flat
2	116-3344	2	ASM-Cutter Hsg With Bearings	19	126-8043	1	Shield-Dust
2:2	116-0720	2	Bearing-Ball	20	3231-31	3	Screw-CARR
2:3	116-3312	1	Spacer-Bearing	21	135-0313	1	Screw-CARR
3	116-3342	2	ASM-Spindle And Seal	22	135-1679	1	ASM.-Arm, Idler
4	116-1286	2	Guard,Bearing Top .989	23	126-9195	1	Shield-Guard, Dust
5	135-4809	2	Sheave-Blade Drive	24	126-9196	1	Idler-Pulley, Flat
6	103-2802	2	Washer	25	103-2916	1	Guard-Top
7	116-7306	2	Nut-Hex	26	126-1680	1	Screw-HHF
8	146-3411	2	Blade-High Flow	27	135-3214	1	Belt-V
9	103-3037	2	Bushing, Splined	28	116-6317	1	Spring-Extension
10	109-9220	2	Screw-Sems	29	116-9981	1	Kit, Anti-Scalp Roller
11	126-2783-01	1	Baffle, Dogleg	30	135-2160	1	Rubber Deflector ASM
12	109-6658	21	Nut-Flange, NI	31	3256-4	1	Washer-Flat
13	104-8300	1	Nut-HF, NI	32	116-8131	1	Axle, Roller
14	3231-25	4	Bolt-CARR	33	103-8415	1	Roller-Anti-Scalp
15	322-2	1	Screw-HH	34	98-5975	1	Washer-Belleville
16	109-2872	3	Spacer-Pulley	35	116-9362	1	Screw-HH
17	135-4398	2	Idler - V 4.13 Eod-A	36	161-3535-03	1	Plate-Badge [black]
				37	130-8451	2	Rivet-Trifold

Deck Decal Assembly

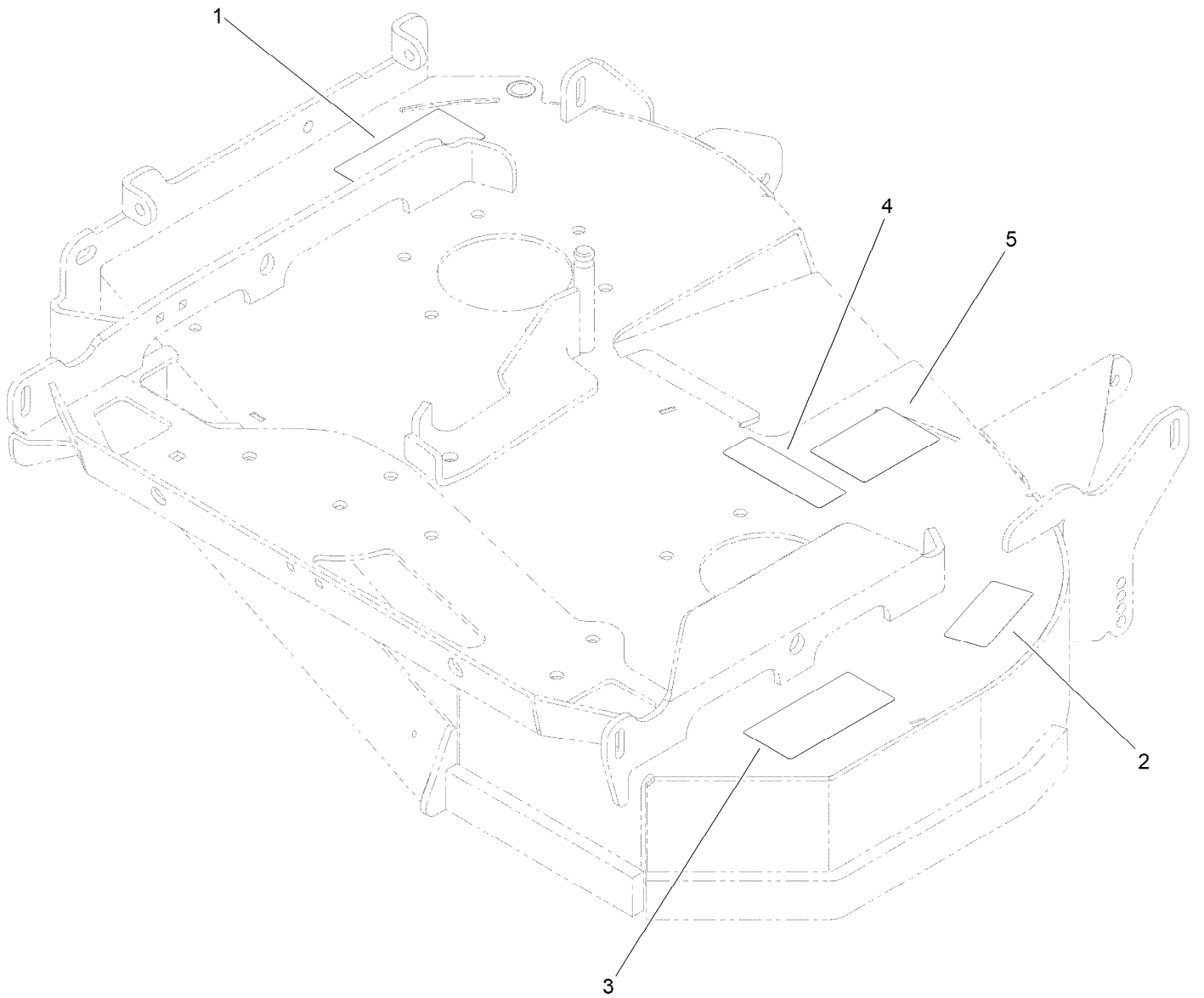

Deck Decal Assembly (continued)

<i>Ref.</i>	<i>Part Number</i>	<i>Qty.</i>	<i>Description</i>	<i>Ref.</i>	<i>Part Number</i>	<i>Qty.</i>	<i>Description</i>
1		1	ASM-Deck W/Decals ●	4	112-9028	1	Decal-Cover, Missing
2	116-8283	1	Decal-Torque, Bolt	5	135-3004	1	Decal-Belt Routing
3	142-6830	2	Decal-Warning Thrown Object				

● Not serviced separately

Idler Arm Assembly No. 135-1679

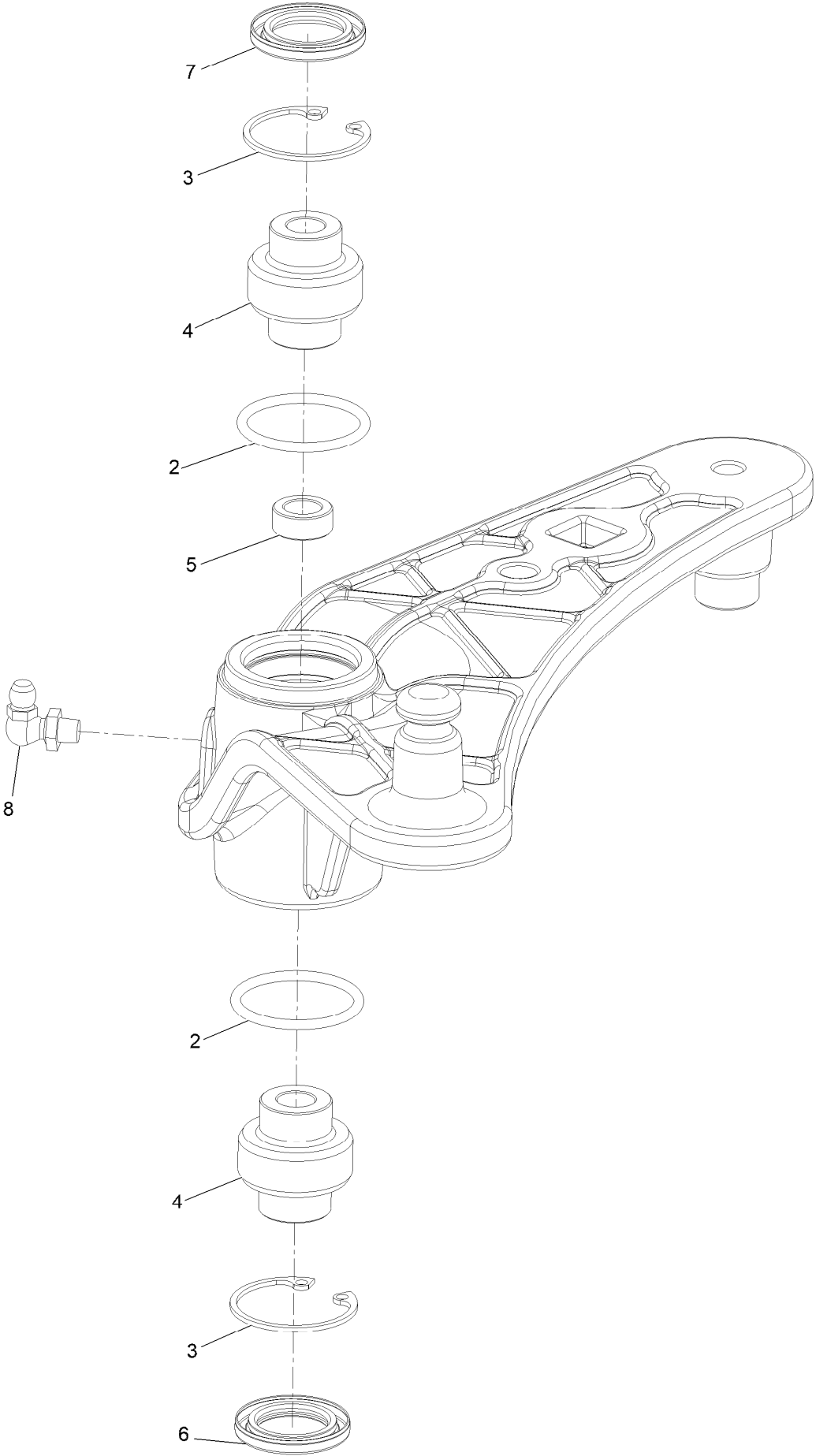

Idler Arm Assembly No. 135-1679 (continued)

<i>Ref.</i>	<i>Part Number</i>	<i>Qty.</i>	<i>Description</i>
2	106-7159	2	O-Ring
3	32120-10	2	Ring-Retaining
4	103-3504	2	Bearing-Spherical
5	103-5677	1	Spacer

<i>Ref.</i>	<i>Part Number</i>	<i>Qty.</i>	<i>Description</i>
6	103-3505	1	Seal-Lip, Double
7	103-3506	1	Seal-Single Lip
8	302-40	1	Zerk-90° 1/4-28

Rubber Deflector Assembly No. 135-2160

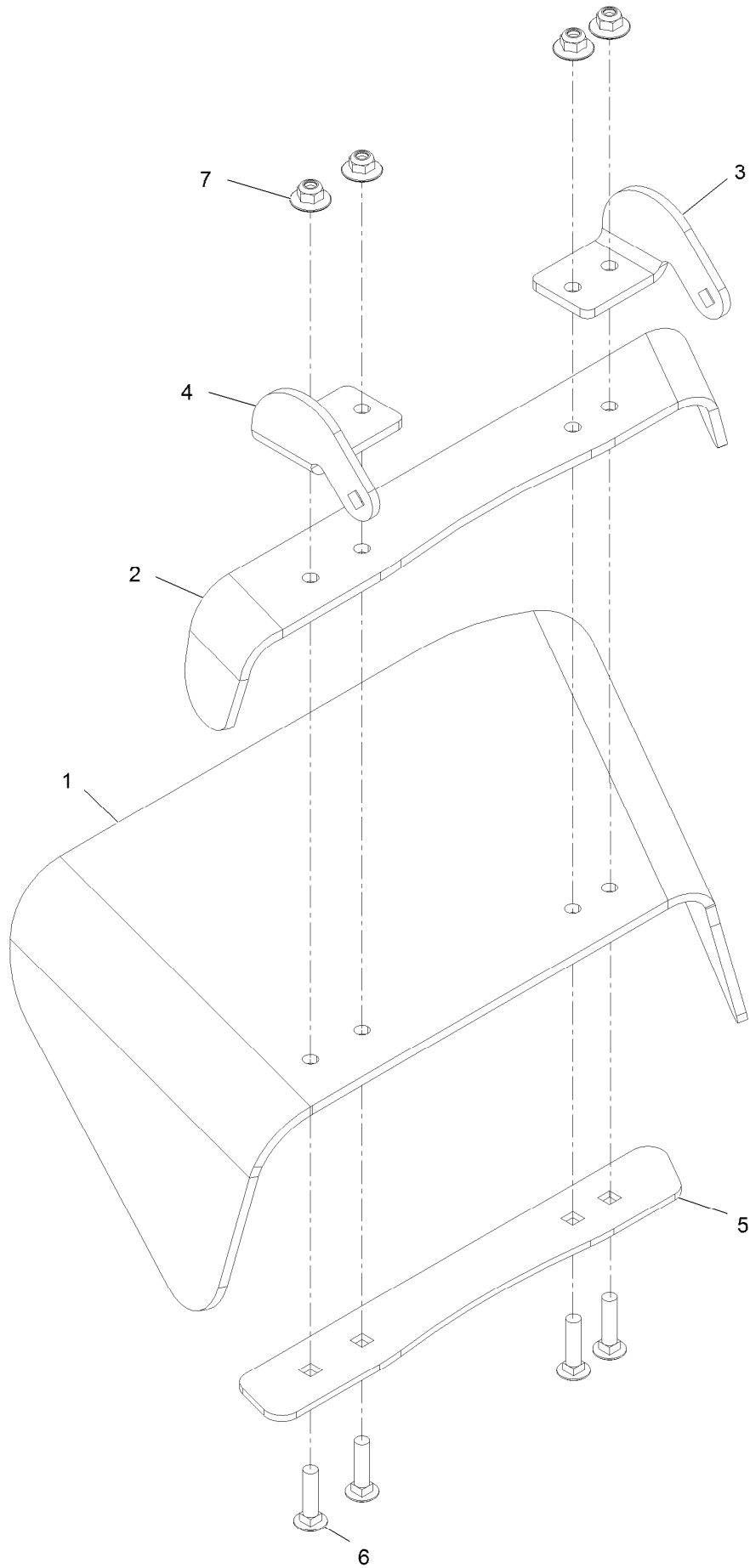

Rubber Deflector Assembly No. 135-2160 (continued)

<i>Ref.</i>	<i>Part Number</i>	<i>Qty.</i>	<i>Description</i>	<i>Ref.</i>	<i>Part Number</i>	<i>Qty.</i>	<i>Description</i>
1	135-2157	1	Deflector-Rubber	5	135-2156-03	1	Strap-Bottom Deflector
2	135-2155-01	1	Bracket-Top Deflector	6	3231-4	4	Bolt-Carriage 3/8-16 X 1 1/2
3	135-2158-01	1	Bracket-Deflector	7	109-6658	4	Nut-Nyloc 3/8-16 Flg
4	135-2159-01	1	Bracket-Deflector				

Drive Wheel Assembly

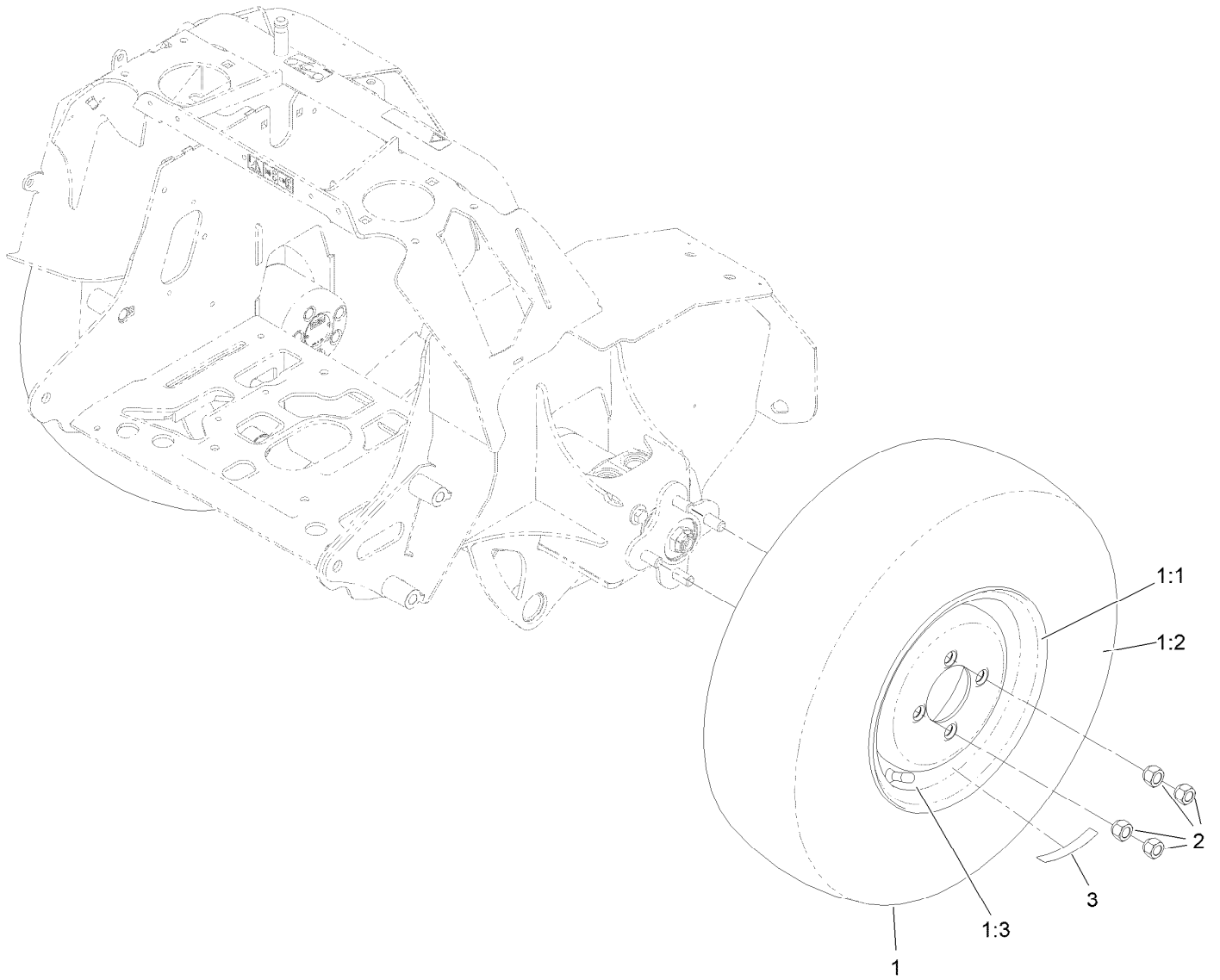

Drive Wheel Assembly (continued)

<i>Ref.</i>	<i>Part Number</i>	<i>Qty.</i>	<i>Description</i>
1	161-3508	2	Wheel And Tire ASM
1:1	161-3507	1	Wheel 10 X 6
1:2	135-1626	1	Tire-21X8.5-10
1:3	232-27	1	Stem-Valve

<i>Ref.</i>	<i>Part Number</i>	<i>Qty.</i>	<i>Description</i>
2	242-50	8	Nut-Lug
3	126-2056	2	Decal-Torque Wheel Lug-Hub

Caster Wheel Assembly

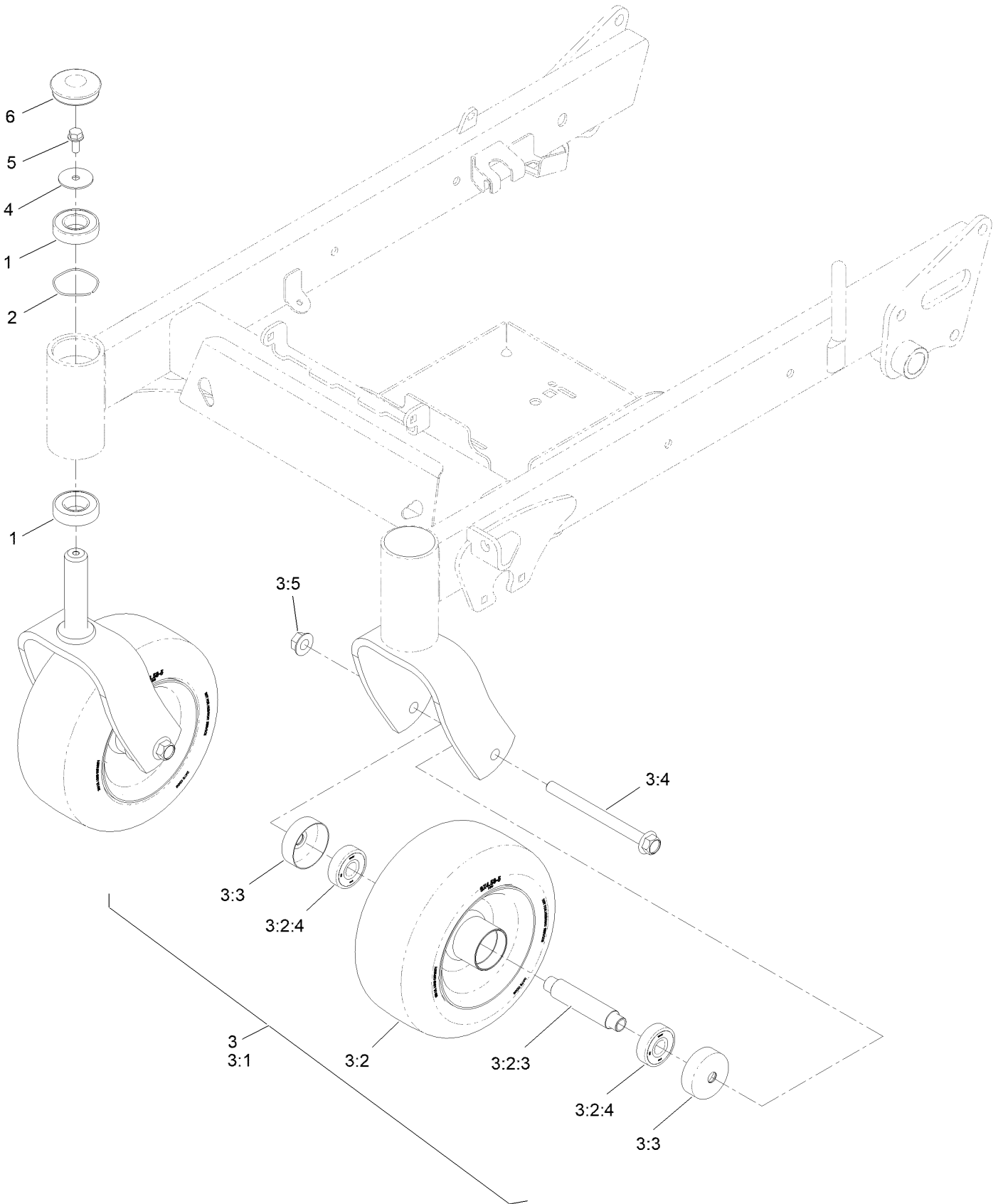

Caster Wheel Assembly (continued)

<i>Ref.</i>	<i>Part Number</i>	<i>Qty.</i>	<i>Description</i>	<i>Ref.</i>	<i>Part Number</i>	<i>Qty.</i>	<i>Description</i>
1	109-3678	4	Bearing-Ball	3:2:4	116-4004	2	Bearing
2	126-5897	2	Spring	3:3	135-3218	2	Guard, Seal
3		2	ASM-Caster Fork W/Tire ●	3:4	135-4633	1	Screw-HHF
3:1	135-1651-01	1	ASM-Caster Fork [red]	3:5	32128-23	1	Nut-HF
3:2	161-3505	1	ASM-Tire & Whl Sp 9X4.50-5	4	3256-68	2	Washer-Flat
3:2:3	126-7904	1	Axle-Caster	5	3234-5	2	Screw-HHF
				6	144-0375	2	Cap, Grease

● Not serviced separately

Attachments and Accessories

For 74535 Grandstand 36in HDM

Product Name	Model/Part
Blade, Medium Flow 18.0 (.94 Hole)	146-3408
6 PACK - BLADE, 18.0 MED FLOW	146-3408P6
Blade, Low Flow 18.0 (.94 Hole)	146-3409
6 PACK - BLADE, 18.0 LOW FLOW	146-3409P6
Blade, Recycler 18.0 (.94 Hole)	146-3410
6 PACK - BLADE, 18.0 RECYCLER	146-3410P6
Blade-high Flow	146-3411
6 PACK - BLADE, 18.0 HIGH FLOW	146-3411P6
Blade-atomic, 18.00"	146-3413
6 PACK - BLADE, 18.0 ATOMIC	146-3413P6

Notes:



Count on it.