



Count on it.

Parts Catalog

**Recycler® S53VST 53cm
Lawn Mower with SmartStow®**

Model No. 21753—Serial No. 40000000 and Up



Ordering Replacement Parts

To order replacement parts, please supply the part number, the quantity, and the description of each part desired.

Understanding Reference Numbers

Each identified part in an illustration has a reference number. The reference number for a part also appears in the parts list, along with other information about the part.

This catalog uses two special reference number formats, one to indicate parts in a service assembly and another to indicate the quantity of a given part in an illustration.

Service Assembly Reference Numbers

Parts in service assemblies have reference numbers in the form a:b. The a represents the reference number of the entire service assembly and the b represents a sequential number unique to each part within the service assembly.

For example, a wheel assembly might be identified by reference number 6, the tire by 6:1, the valve by 6:2, and the wheel by 6:3. When you order the assembly identified by reference number 6, you receive all parts identified by reference numbers 6:1, 6:2, and 6:3. However, you may also order any part individually. Reference numbers of this type appear in illustration and in parts lists.

Reference Numbers Indicating Quantity

In an illustration, if a reference number indicates more than one part, the reference number has the form nX y. The n represents the quantity of the part, the X is the multiplication symbol, and the y represents the reference number.

For example, in an illustration, the reference number 2X 37 means that two of the parts identified by reference number 37 are indicated.

Contents

| | |
|--|----|
| Housing Assembly | 4 |
| Grass Bag and Frame Assembly | 6 |
| Engine and Blade Assembly | 8 |
| Front Wheel and Height-of-Cut Assembly | 10 |
| Rear Wheel and Height-of-Cut Assembly | 12 |
| Handle Assembly | 14 |
| Attachments and Accessories | 16 |

Housing Assembly

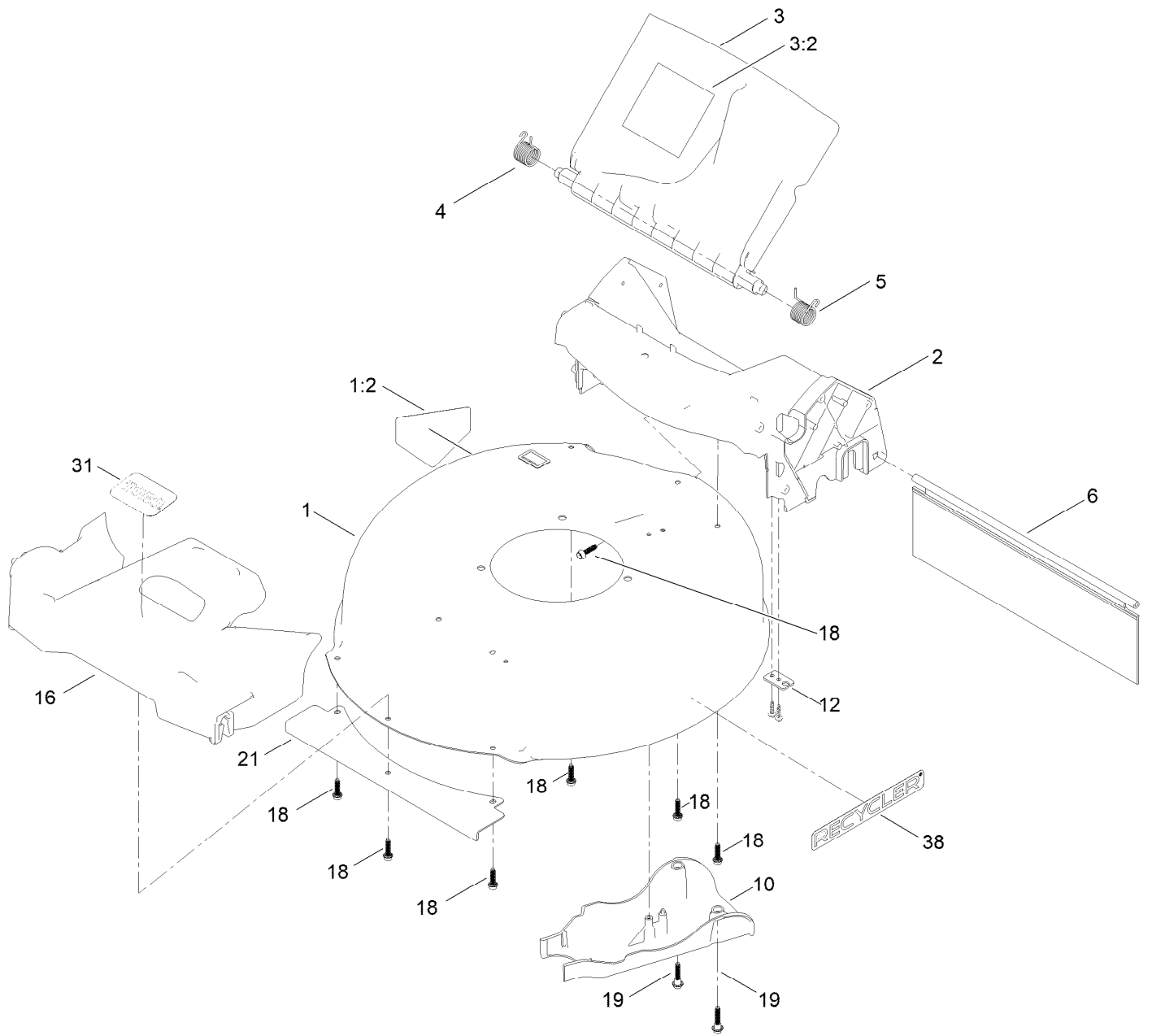

Housing Assembly (continued)

| <i>Ref.</i> | <i>Part Number</i> | <i>Qty.</i> | <i>Description</i> | <i>Ref.</i> | <i>Part Number</i> | <i>Qty.</i> | <i>Description</i> |
|-------------|--------------------|-------------|---------------------|-------------|--------------------|-------------|-----------------------|
| 1 | 145-5525-01 | 1 | Housing-Deck | 10 | 127-0723 | 1 | Cover-Belt |
| 1:2 | 112-8760 | 1 | Decal-Danger | 12 | 127-0730 | 1 | Bracket-Cable |
| 2 | 145-5506 | 1 | Chute-Sp/Awd, 21 In | 16 | 145-5518 | 1 | Bumper |
| 3 | 145-5511 | 1 | Deflector-Rear ASM | 18 | 130-6658 | 7 | Screw-Flange, Plastic |
| 3:2 | 117-4143 | 1 | Decal-Warning | 19 | 131-0837 | 2 | Screw-Shoulder, HHF |
| 4 | 147-0465 | 1 | Spring-Torsion | 21 | 131-0820-03 | 1 | Shield-Front |
| 5 | 147-0466 | 1 | Spring-Torsion | 31 | 145-0854 | 1 | Decal-Toro, Silver |
| 6 | 147-0443 | 1 | Shield-Trailing | 38 | 140-4184 | 2 | Decal |

Grass Bag and Frame Assembly

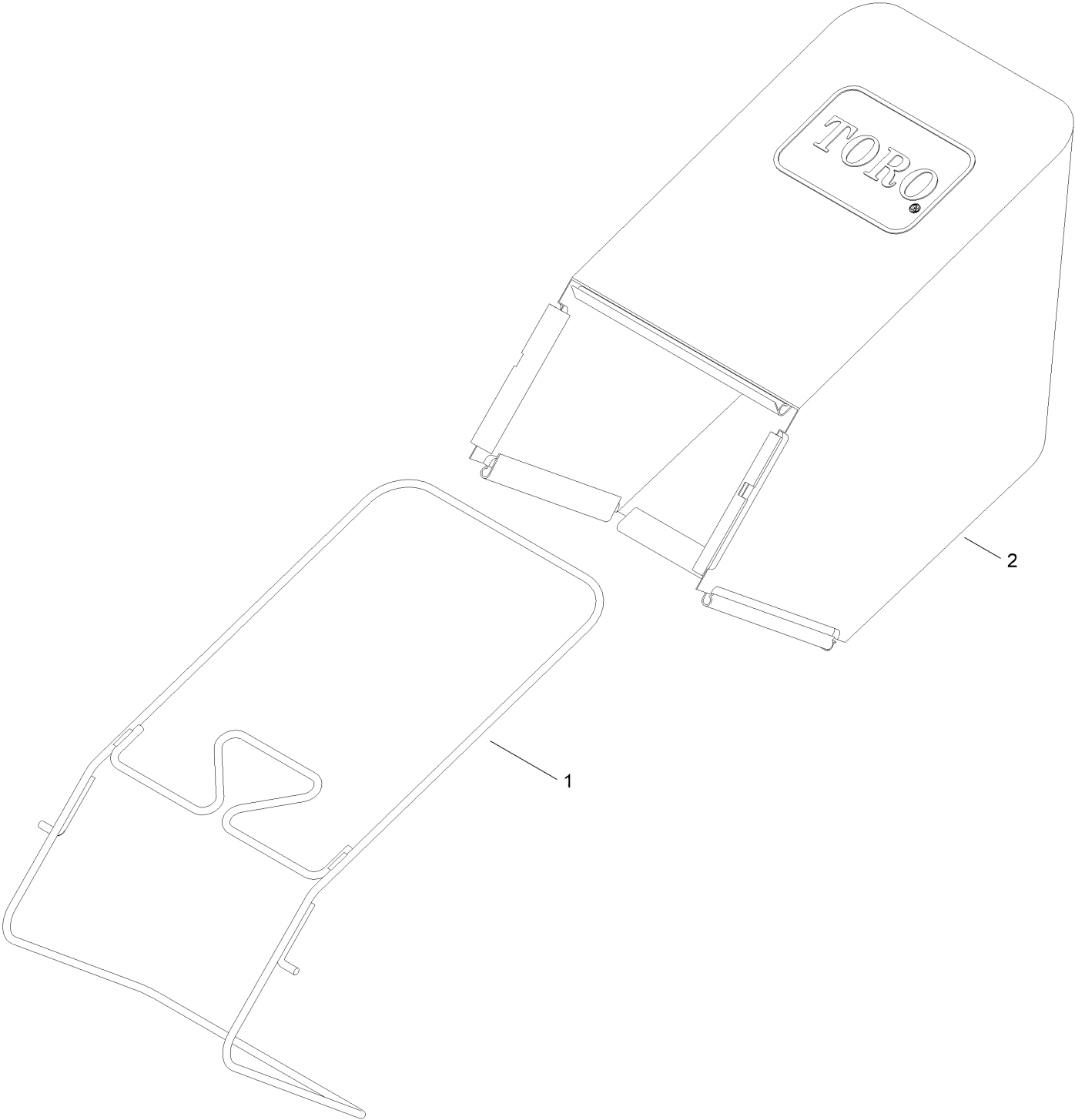

Grass Bag and Frame Assembly (continued)

| <i>Ref.</i> | <i>Part Number</i> | <i>Qty.</i> | <i>Description</i> |
|-------------|--------------------|-------------|--------------------|
| 1 | 145-5512-03 | 1 | Frame-Bag |
| 2 | 147-0418 | 1 | Bag ASM |

Engine and Blade Assembly

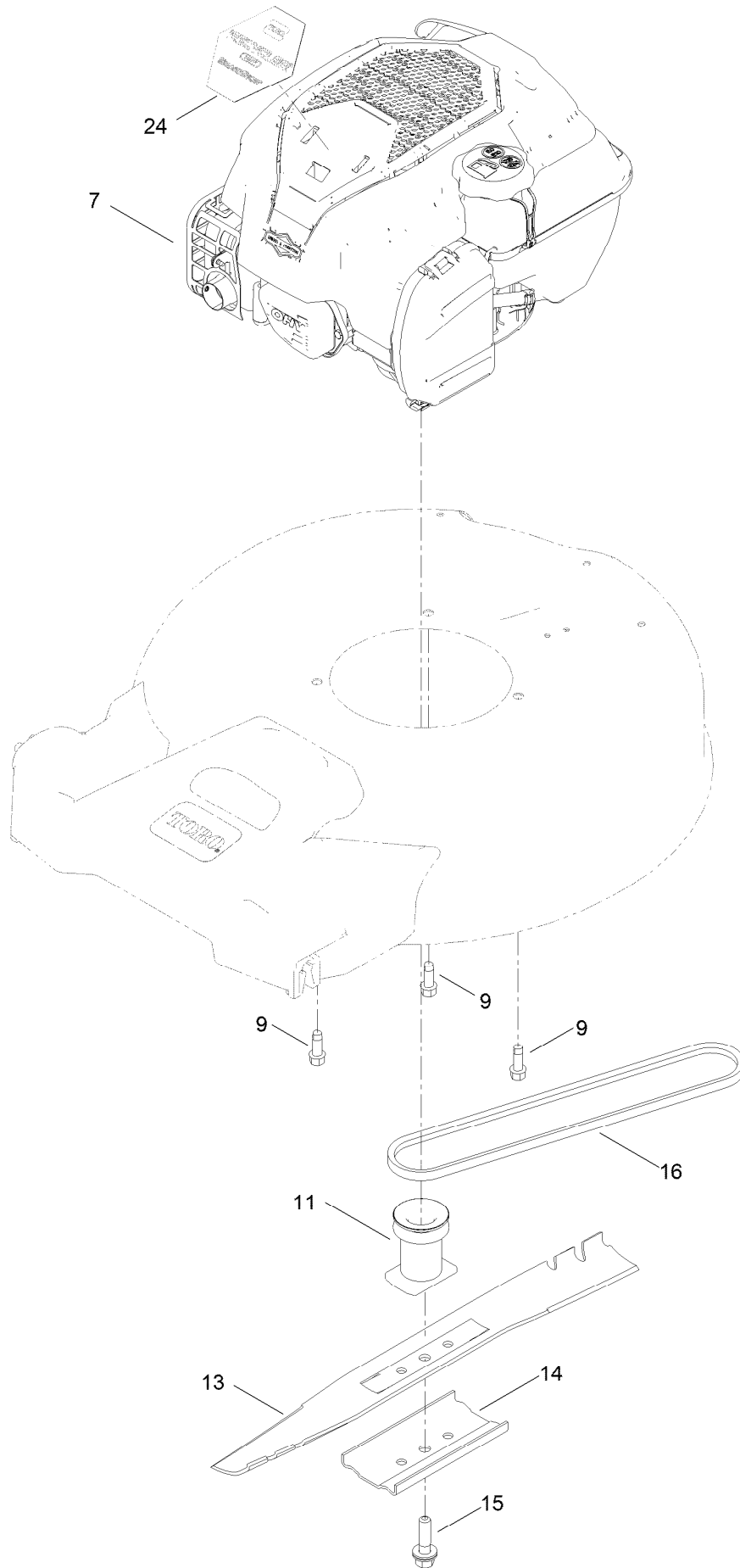

Engine and Blade Assembly (continued)

| <i>Ref.</i> | <i>Part Number</i> | <i>Qty.</i> | <i>Description</i> | <i>Ref.</i> | <i>Part Number</i> | <i>Qty.</i> | <i>Description</i> |
|-------------|--------------------|-------------|----------------------------------|-------------|--------------------|-------------|------------------------|
| 7 | | 1 | Engine-Briggs,104M020130F1 ●■ | 14 | 108-3766-03 | 1 | Support-Blade |
| 9 | 95-1726 | 3 | Screw-Taptite | 15 | 125-2466 | 1 | Bolt-Blade |
| 11 | 139-1816 | 1 | Driver-Blade | 16 | 115-4669 | 1 | Belt-V |
| 13 | 133-8182-03 | 1 | Blade-21In | 24 | 147-0569 | 1 | Decal-Briggs Gts SS CE |

● Not serviced separately

■ Obtain parts from www.briggsandstratton.com

Front Wheel and Height-of-Cut Assembly

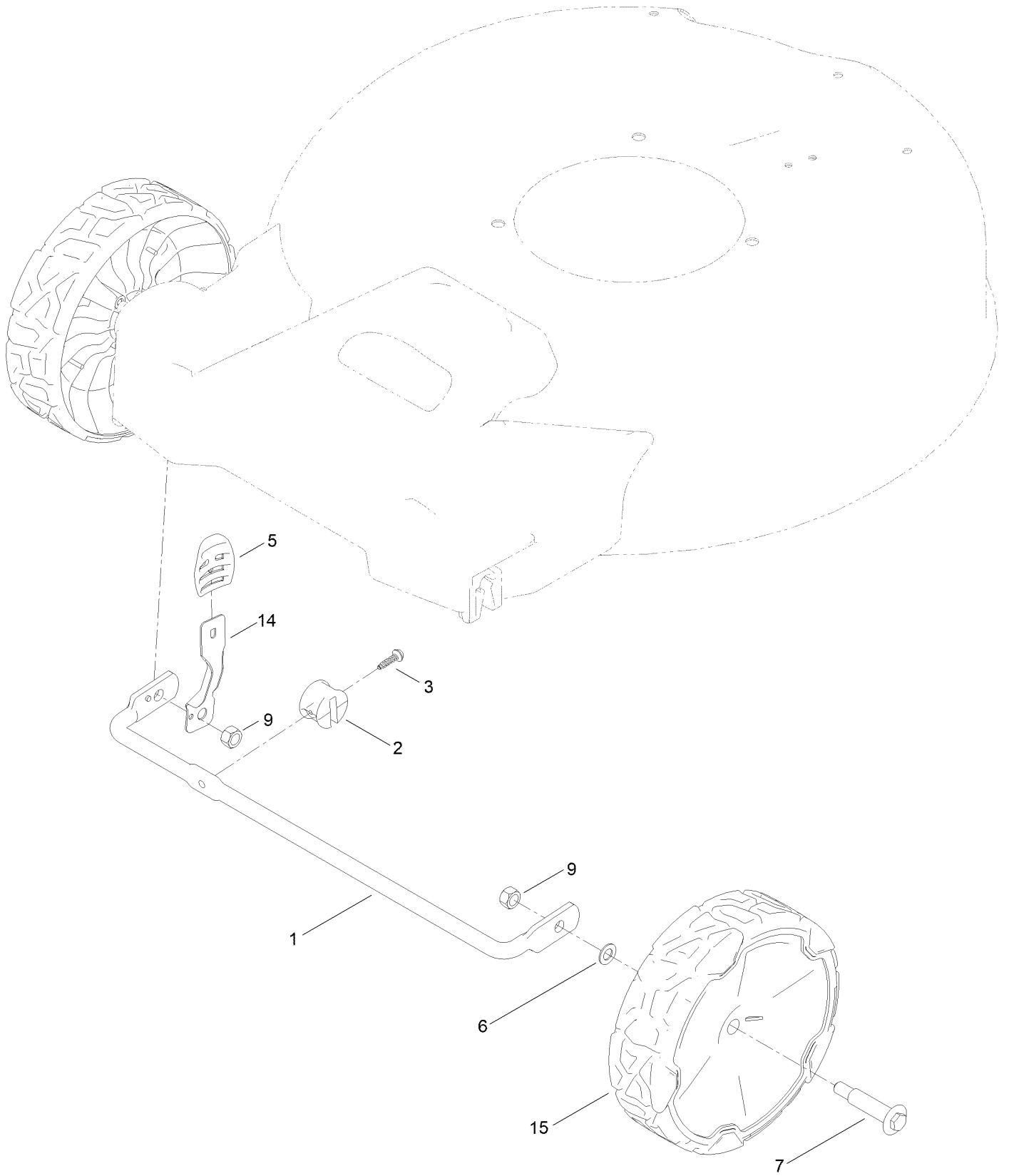

Front Wheel and Height-of-Cut Assembly (continued)

| <i>Ref.</i> | <i>Part Number</i> | <i>Qty.</i> | <i>Description</i> | <i>Ref.</i> | <i>Part Number</i> | <i>Qty.</i> | <i>Description</i> |
|-------------|--------------------|-------------|--------------------|-------------|--------------------|-------------|---------------------|
| 1 | 127-0668-03 | 1 | Axle-Front | 7 | 92-1057 | 2 | Bolt-Shoulder |
| 2 | 127-6800 | 1 | Stop-Axle | 9 | 603773 | 2 | Nut-Hex Lock |
| 3 | 139-1690 | 1 | Screw-Plastic, HWH | 14 | 147-0435 | 1 | Arm-Spring |
| 5 | 105-3042 | 1 | Knob-Lever, HOC | 15 | 140-2355 | 2 | ASM-8" Wheel, Idler |
| 6 | 40-1940 | 2 | Washer | | | | |

Rear Wheel and Height-of-Cut Assembly

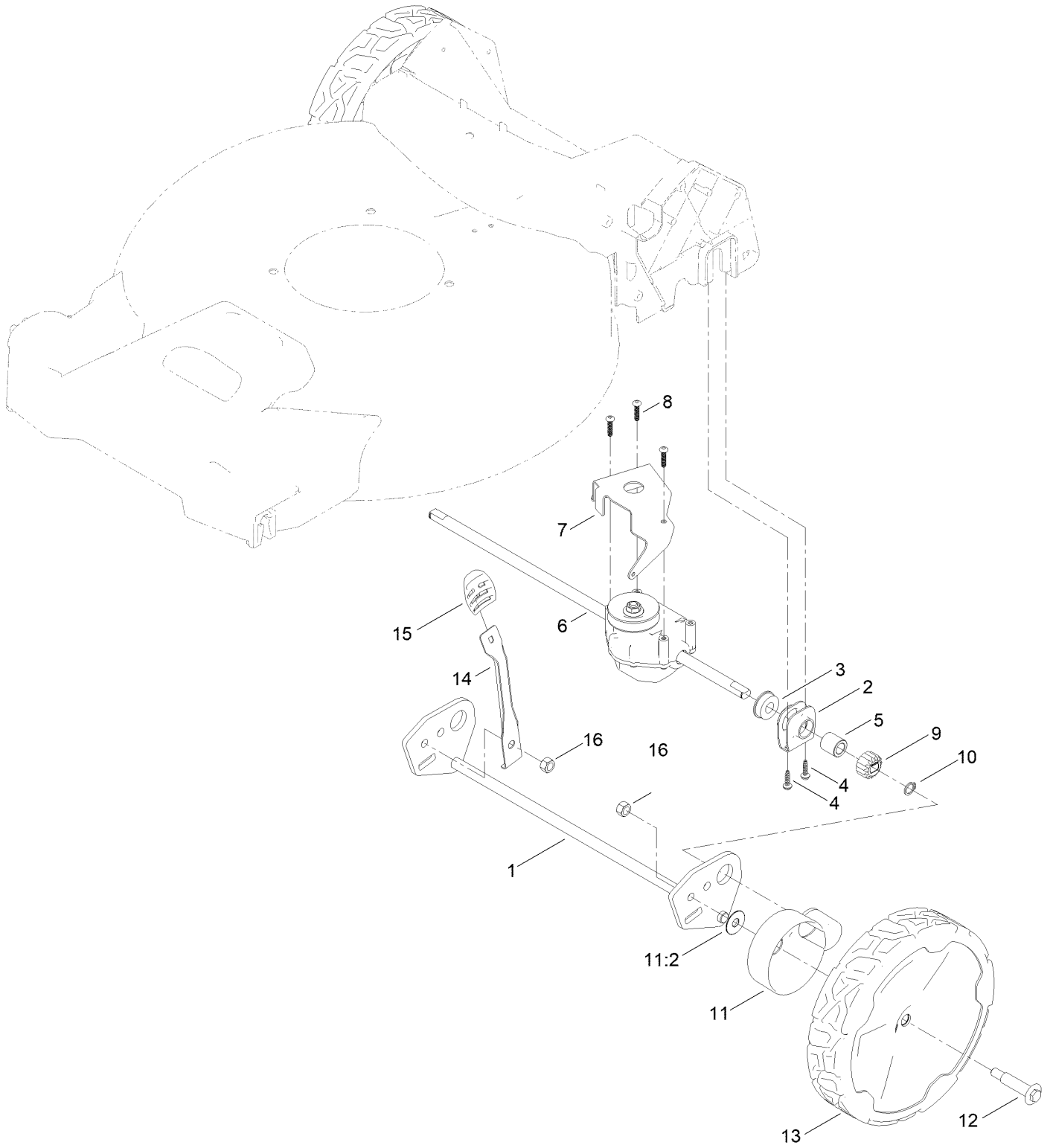

Rear Wheel and Height-of-Cut Assembly (continued)

| <i>Ref.</i> | <i>Part Number</i> | <i>Qty.</i> | <i>Description</i> | <i>Ref.</i> | <i>Part Number</i> | <i>Qty.</i> | <i>Description</i> |
|-------------|--------------------|-------------|--------------------------|-------------|--------------------|-------------|---------------------------|
| 1 | 145-5501-03 | 1 | Axle-Rear, Wa | 10 | 32151-61 | 2 | Ring-Retaining |
| 2 | 138-3234 | 2 | Retainer-Bearing | 11 | 140-2362 | 2 | ASM-Cover, Gear (Dk Gray) |
| 3 | 104-8699 | 2 | Bearing-Ball | 11:2 | 614426 | 1 | Washer-Stepped |
| 4 | 139-1690 | 4 | Screw-Plastic, HWH | 12 | 92-1057 | 2 | Bolt-Shoulder |
| 5 | 127-6896 | 2 | Bushing-Sleeve | 13 | 140-2350 | 2 | ASM-9.65" Wheel, Geared |
| 6 | 145-5515 | 1 | Transmission (7:1 Ratio) | 14 | 147-0437 | 1 | Arm-Spring |
| 7 | 145-5513-03 | 1 | Bracket-Transmission | 15 | 105-3042 | 1 | Knob-Lever, HOC |
| 8 | 120-9676 | 3 | Screw-Plastite | 16 | 603773 | 2 | Nut-Hex Lock |
| 9 | 131-5399 | 2 | Gear-Pinion, 15T | | | | |

Handle Assembly

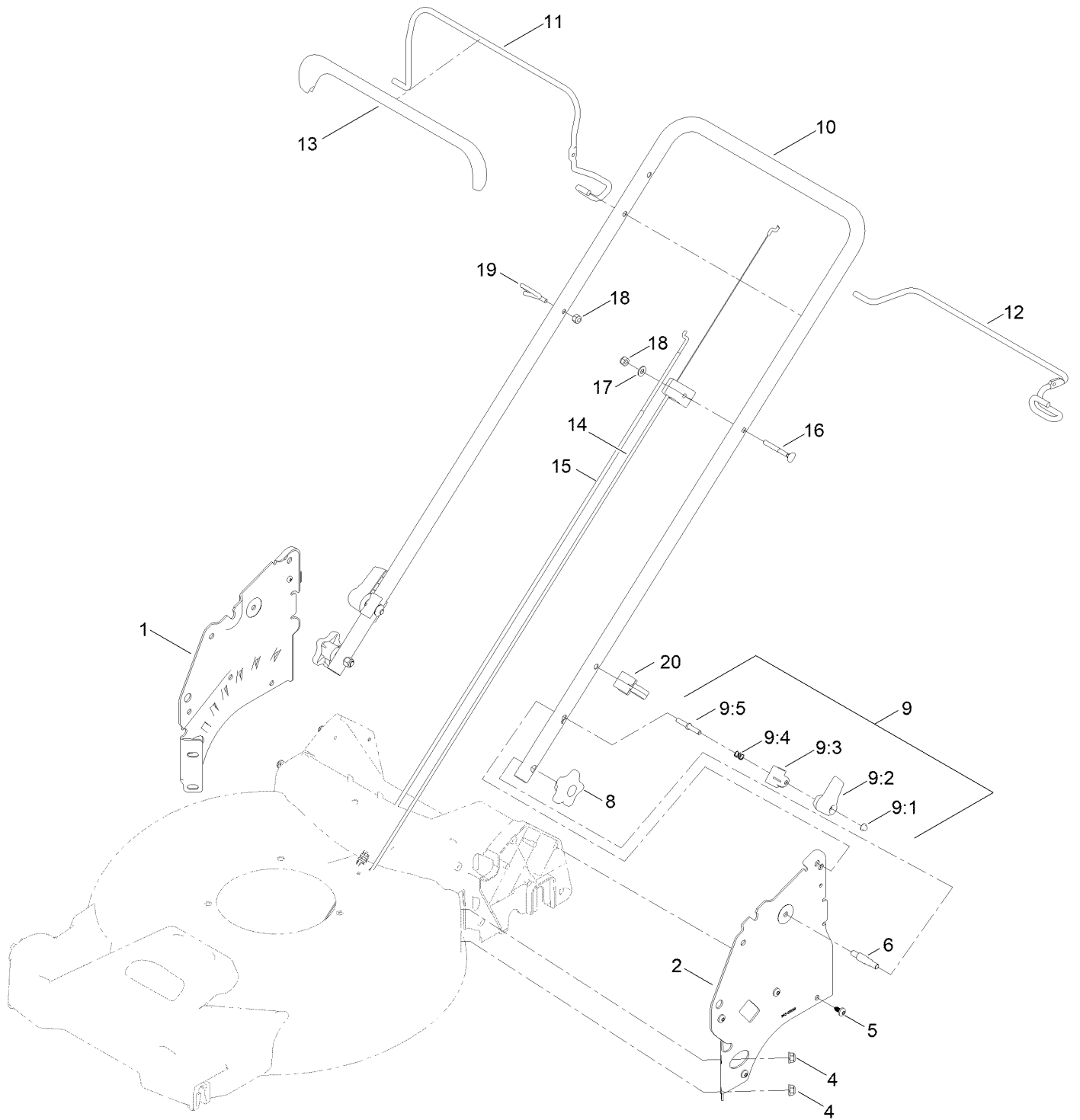

Handle Assembly (continued)

| <i>Ref.</i> | <i>Part Number</i> | <i>Qty.</i> | <i>Description</i> | <i>Ref.</i> | <i>Part Number</i> | <i>Qty.</i> | <i>Description</i> |
|-------------|--------------------|-------------|-----------------------|-------------|--------------------|-------------|--------------------|
| 1 | 145-5507-05 | 1 | Plate-Handle, RH | 10 | 145-5509-05 | 1 | Handle-Upper |
| 2 | 145-5508-05 | 1 | Plate-Handle, LH | 11 | 138-3270-03 | 1 | Bail-Brake |
| 4 | 138-8401 | 4 | Nut-HF | 12 | 137-4799-03 | 1 | Bail-Traction |
| 5 | 139-1679 | 8 | Screw-Plastic,PH | 13 | 137-4797 | 1 | Cover-Bail |
| 6 | 139-6588 | 2 | Bolt-Shoulder, Handle | 14 | 112-8818 | 1 | Cable-Brake |
| 8 | 117-5976 | 2 | Knob-Handle | 15 | 127-0733 | 1 | Cable-Traction |
| 9 | 138-3249 | 2 | Quick Release ASM | 16 | 139-1701 | 1 | Screw-Handle |
| 9:1 | 140-4157 | 1 | Nut-Push | 17 | 139-1699 | 1 | Washer-Flat |
| 9:2 | 138-3248 | 1 | Lever-Release | 18 | 137-3094 | 2 | Nut-Hex |
| 9:3 | 138-3253 | 1 | Anchor-Spring | 19 | 86-9671 | 1 | Guide-Rope |
| 9:4 | 115-2858 | 1 | Spring-Compression | 20 | 114-7988 | 1 | Guide-Cable |
| 9:5 | 140-4158 | 1 | Rod-Release | | | | |

Attachments and Accessories

For 21753 Recycler S53VST 53cm Lawn Mower with SmartStow

| Product Name | Model/Part |
|--|-------------------|
| Smart Stow Walk Power Mower Cover | 490-2012 |
| Lawn Striping Kit with 22in Roller..... | 20601 |
| Bag-Walk Behind (Toro)..... | 490-7318 |
| Fuel Stabilizer .05 oz | 130-2393 |
| Summer Oil-Case of 24 (20oz Bottles)..... | 38916 |
| 4-Cycle Fuel, Snow And Lawn 32oz Can | 131-3823 |
| Oil-30/10W-30 Synthetic (Quart)..... | 138-6053 |
| Toro Premium Fuel Treatment 12oz Bottle..... | 131-6572 |

For 21753 Recycler S53VST 53cm Lawn Mower with SmartStow

| Product Name | Model/Part |
|--|-------------------|
| SD Chute Kit..... | 147-0520 |
| Smart Stow Walk Power Mower Cover | 490-2012 |
| Lawn Striping Kit with 22in Roller..... | 20601 |
| Bag-Walk Behind (Toro)..... | 490-7318 |
| Fuel Stabilizer .05 oz | 130-2393 |
| Summer Oil-Case of 24 (20oz Bottles)..... | 38916 |
| 4-Cycle Fuel, Snow And Lawn 32oz Can | 131-3823 |
| Oil-30/10W-30 Synthetic (Quart)..... | 138-6053 |
| Toro Premium Fuel Treatment 12oz Bottle..... | 131-6572 |

Notes:

Notes:

Notes:



Count on it.