



Count on it.

Parts Catalog

TimeMaster 30in

Lawn Mower

Model No. 21220—Serial No. 40000000 and Up



Ordering Replacement Parts

To order replacement parts, please supply the part number, the quantity, and the description of each part desired.

Understanding Reference Numbers

Each identified part in an illustration has a reference number. The reference number for a part also appears in the parts list, along with other information about the part.

This catalog uses two special reference number formats, one to indicate parts in a service assembly and another to indicate the quantity of a given part in an illustration.

Service Assembly Reference Numbers

Parts in service assemblies have reference numbers in the form a:b. The a represents the reference number of the entire service assembly and the b represents a sequential number unique to each part within the service assembly.

For example, a wheel assembly might be identified by reference number 6, the tire by 6:1, the valve by 6:2, and the wheel by 6:3. When you order the assembly identified by reference number 6, you receive all parts identified by reference numbers 6:1, 6:2, and 6:3. However, you may also order any part individually. Reference numbers of this type appear in illustration and in parts lists.

Reference Numbers Indicating Quantity

In an illustration, if a reference number indicates more than one part, the reference number has the form nX y. The n represents the quantity of the part, the X is the multiplication symbol, and the y represents the reference number.

For example, in an illustration, the reference number 2X 37 means that two of the parts identified by reference number 37 are indicated.

Contents

Housing Assembly	4
Spindle and Belt Assembly	6
Side Discharge Chute Assembly	8
Bag Assembly	10
Engine and Belt Assembly	12
Front Wheel and Height-of-Cut Assembly	14
Rear Wheel and Height-of-Cut Assembly	16
Handle Assembly	18
Attachments and Accessories	20

Housing Assembly

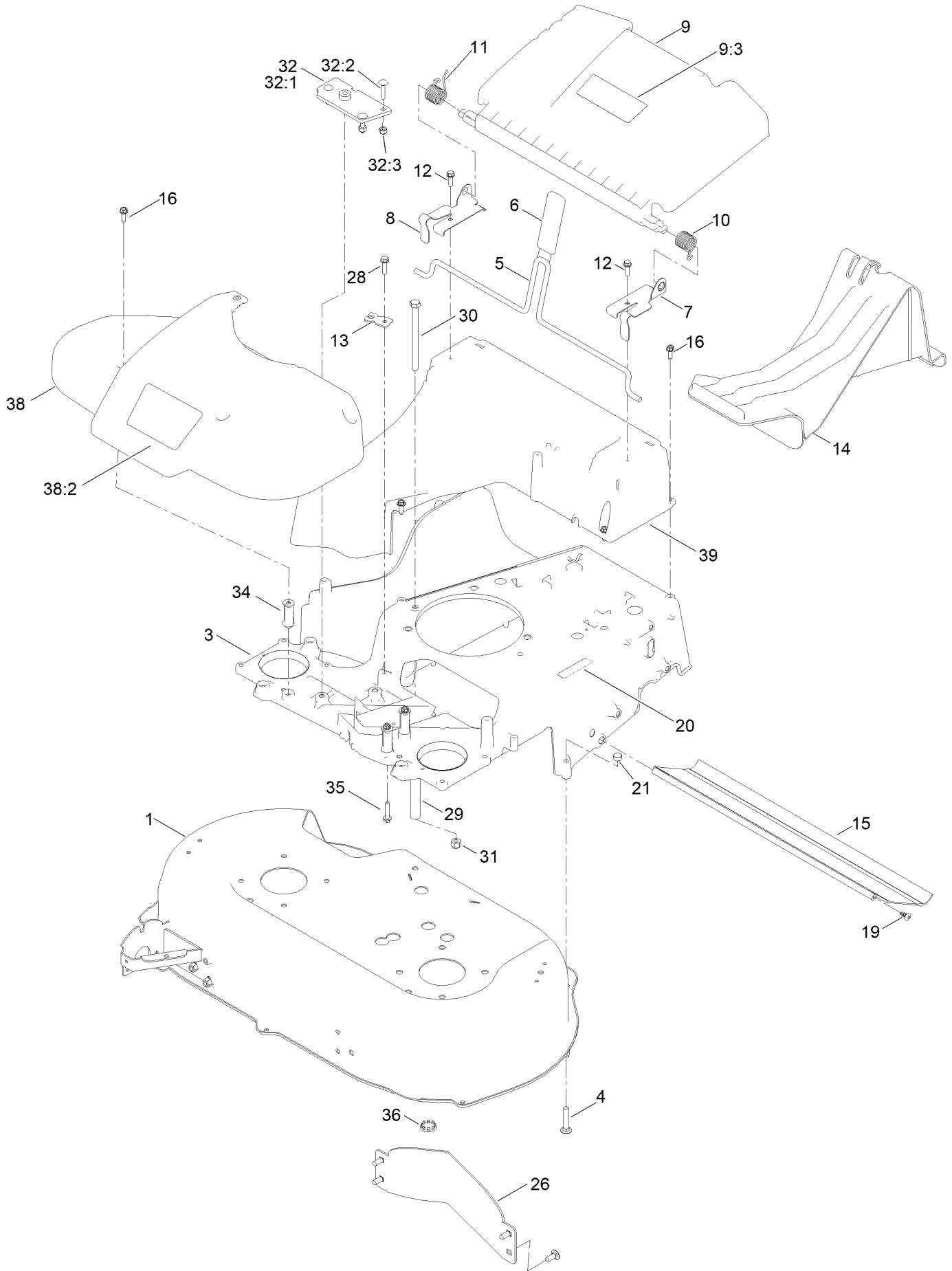

Housing Assembly (continued)

<i>Ref.</i>	<i>Part Number</i>	<i>Qty.</i>	<i>Description</i>	<i>Ref.</i>	<i>Part Number</i>	<i>Qty.</i>	<i>Description</i>
1	136-5873	1	Housing ASM	20	133-8062	1	Decal-Spark Arrestor
3	140-3977-01	1	Frame-30"	21	3296-29	2	Nut-Lock, NI
4	3230-5	2	Bolt-CARR	26	130-2352-01	1	Baffle-Control
5	139-5415	1	Rod-Release, Handle	28	32144-86	1	Screw-HWHTF
6	120-7018	1	Grip-Lever	29	1-323283	1	Spacer-Shield
7	121-9114	1	Bracket-Door, LH	30	139-5409	1	Screw-HH
8	121-9115	1	Bracket-Door, RH	31	137-3087	1	Nut-Hex
9	120-7048	1	Rear Deflector ASM	32	125-5072	1	Frame Plate Kit
9:3	131-4514	1	Decal-Warning	32:1	125-2542	1	Plate-Frame
10	115-2859	1	Spring-Torsion	32:2	3229-3	3	Screw-CARR
11	114-7924	1	Spring-Torsion	32:3	3296-42	3	Nut-Lock, NI
12	46-8091	3	Screw-HWH	34	140-3901	3	Spacer-Frame, 30 In.
13	138-3224	2	Bracket-Cable, Traction	35	108-4862	3	Screw-HWH Thd Roll
14	120-5225	1	Plug-Mulch	36	147-0471	1	Plug-Button
15	120-6241	1	Shield-Trailing	38	139-5408	1	Belt Cover ASM
16	49-2040	8	Screw-HWHTF	38:2	121-2391	1	Decal-Cover, Belt
19	117-1092	2	Screw-PTH	39	133-8177	1	Chute

Spindle and Belt Assembly

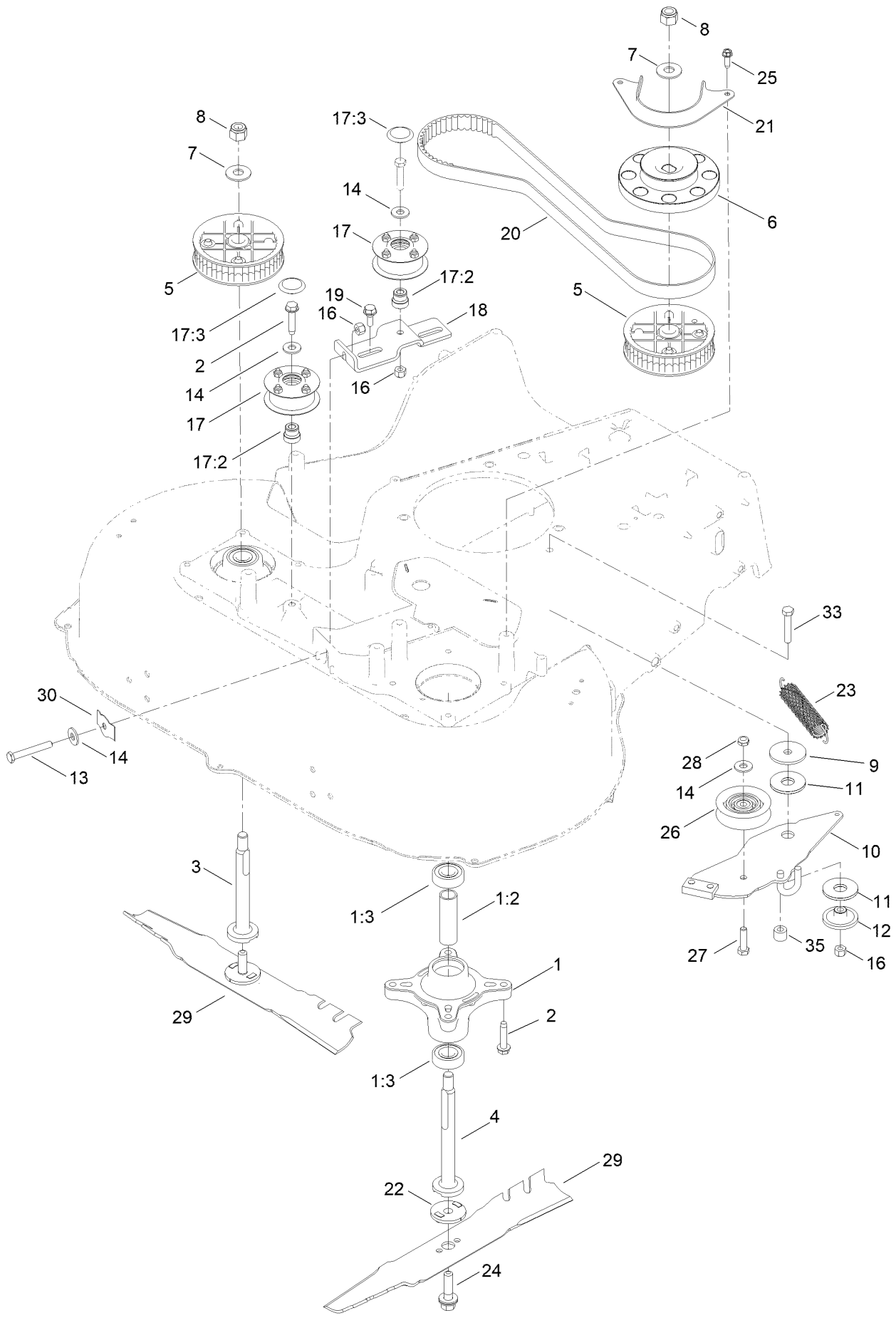

Spindle and Belt Assembly (continued)

<i>Ref.</i>	<i>Part Number</i>	<i>Qty.</i>	<i>Description</i>	<i>Ref.</i>	<i>Part Number</i>	<i>Qty.</i>	<i>Description</i>
1	121-9107	2	Spindle ASM	17:2	131-4504	1	Adapter-Bore
1:2	120-7935	2	Spacer	17:3	125-2533	1	Plug-Cap
1:3	138-9770	2	Bearing-Ball	18	145-4016	1	Bracket-Idler
2	139-1731	9	Screw-Thd Roll, HWH	19	120-7024	2	Screw-Shoulder, HWH
3	139-6612	1	Shaft-Spindle	20	120-3335	1	Belt-Synchronous
4	139-6613	1	Shaft-Spindle	21	120-5245-03	1	Guide-Belt, Spindle
5	121-9100	2	Sprocket	22	120-5236	2	Adapter-Blade
6	130-6664	1	Pulley-Brake, Spindle	23	121-5808	1	Spring-Extension, Brake
7	109-9505	2	Washer-Spring	24	125-2466	2	Bolt-Blade
8	3296-19	2	Nut-Hex	25	49-2040	2	Screw-HWHTF
9	63-7400	1	Washer-Rebound	26	120-7082	1	Pulley-Idler
10	133-8102	1	Brake Arm ASM	27	322-6	1	Screw-HH
11	121-2305	2	Washer-Friction, Composite	28	3296-47	1	Nut-Lock,NI
12	138-3244	1	Spacer	29	116-6358-03	2	Blade-Rotary
13	9114524	1	Bolt-TAP, HH	30	121-2336	1	Spring-Flat
14	139-1723	4	Washer-Flat	33	322-9	1	Screw-HH
16	3296-29	3	Nut-Lock, NI	35	133-1964	1	Spacer
17	131-4529	2	Pulley Kit				

Side Discharge Chute Assembly

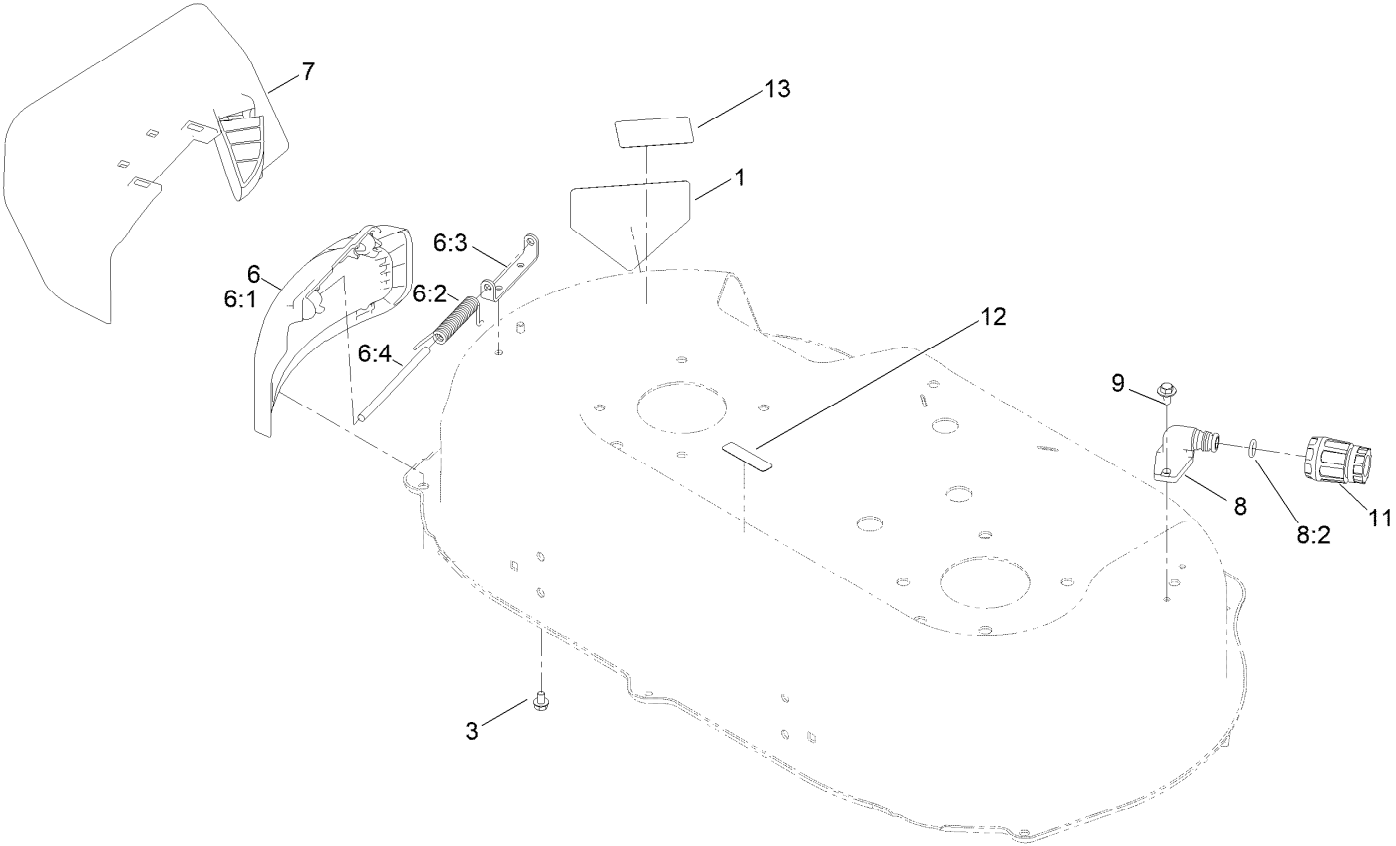

Side Discharge Chute Assembly (continued)

<i>Ref.</i>	<i>Part Number</i>	<i>Qty.</i>	<i>Description</i>	<i>Ref.</i>	<i>Part Number</i>	<i>Qty.</i>	<i>Description</i>
1	94-8072	1	Decal-Danger	7	121-2319	1	Chute-Discharge, Side
3	137-4795	2	Screw	8	133-9289	1	Fitting-Washout
6	133-2630	1	Side Deflector Service ASM	8:2	133-9290	1	O-Ring
			●	9	139-1700	2	Screw-HWH, Thd Roll
6:1	125-5091	1	Deflector-Side	11	95-3270	1	Connector-Hose
6:2	127-0721	1	Spring-Torsion, Cover	12	120-9570	1	Decal-Warning
6:3	112-6416	1	Bracket-Cover	13	125-5092	1	Decal-Placement, Foot
6:4	99-5291	1	Rod-Cover				

● Not serviced separately

Bag Assembly

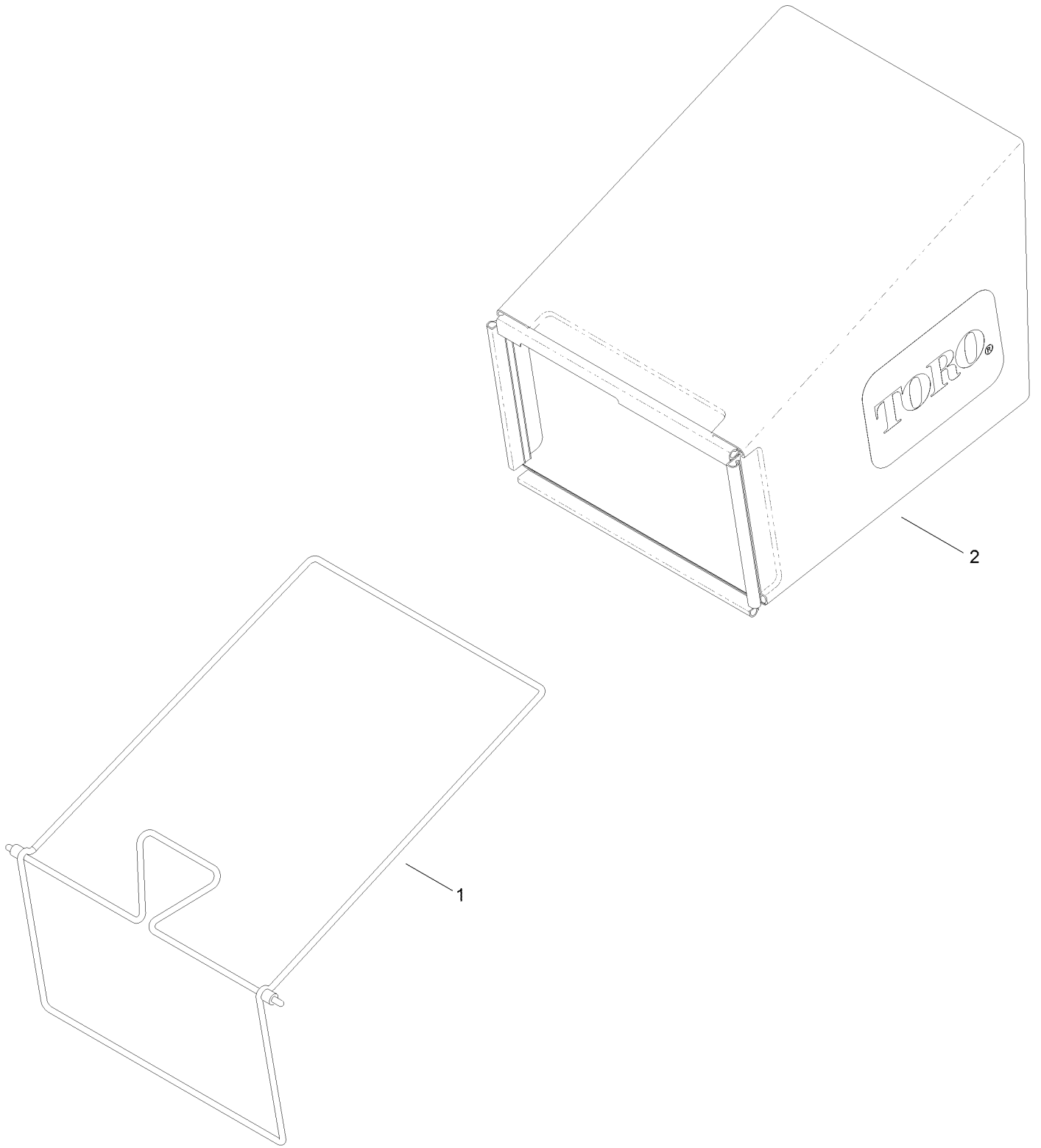

Bag Assembly (continued)

<i>Ref.</i>	<i>Part Number</i>	<i>Qty.</i>	<i>Description</i>
1	121-5766-03	1	Frame-Bag
2	121-5770	1	Bag-Grass

Engine and Belt Assembly

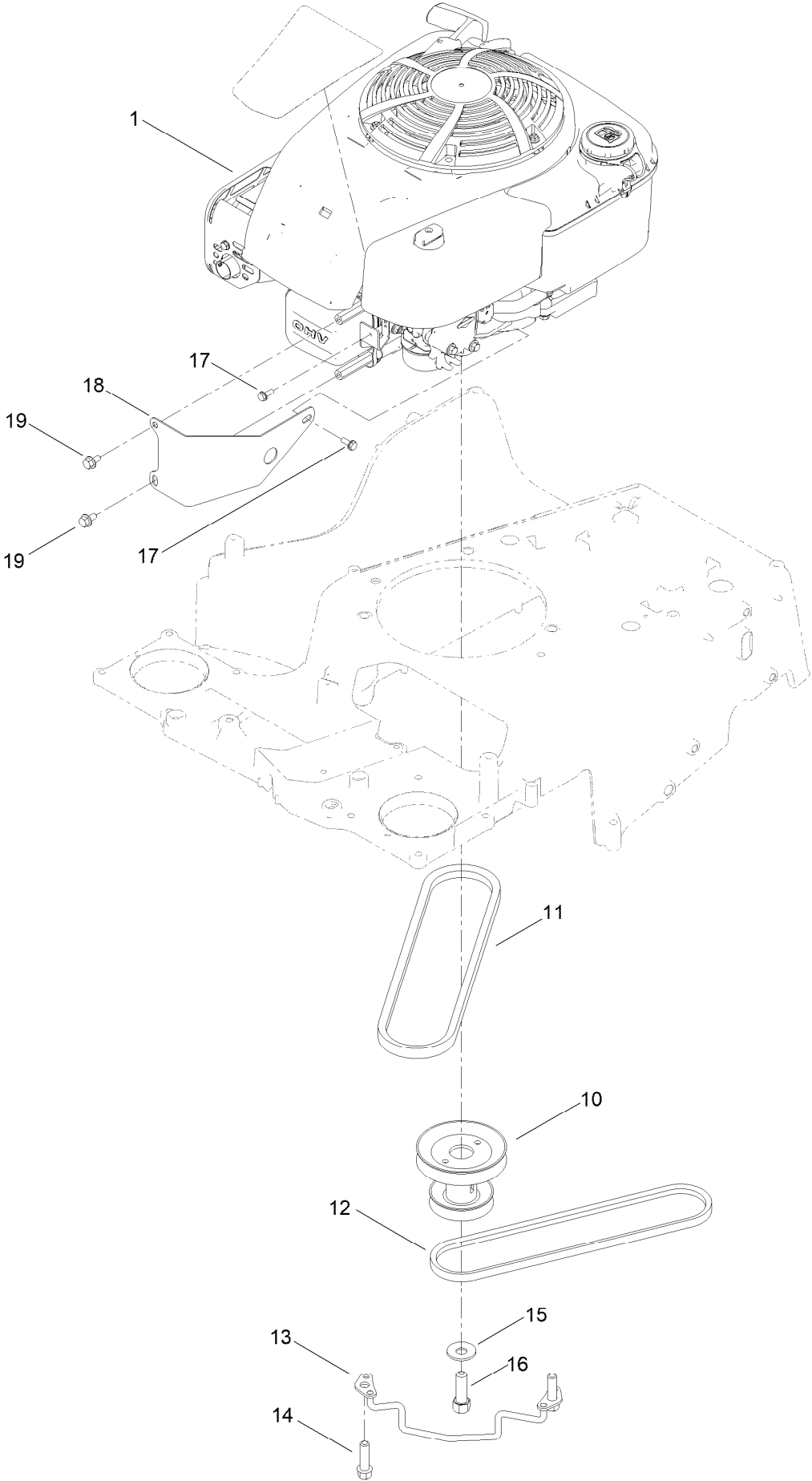

Engine and Belt Assembly (continued)

<i>Ref.</i>	<i>Part Number</i>	<i>Qty.</i>	<i>Description</i>	<i>Ref.</i>	<i>Part Number</i>	<i>Qty.</i>	<i>Description</i>
1		1	Engine-Briggs,14D9350111F1 ●■	14	95-1727	3	Screw-Taptite
10	137-9176	1	Pulley-Engine	15	3290-465	1	Washer-Belleville
11	121-5765	1	V-Belt	16	26-0671	1	Screw-HH
12	120-9470	1	V-Belt, Traction	17	32144-1	2	Screw-Taptite
13	139-1734	1	Guide-Belt, Wa	18	131-0889-03	1	Guard-Engine
				19	126-2713	2	Screw-HHF

● Not serviced separately

■ Obtain parts from www.briggsandstratton.com

Front Wheel and Height-of-Cut Assembly

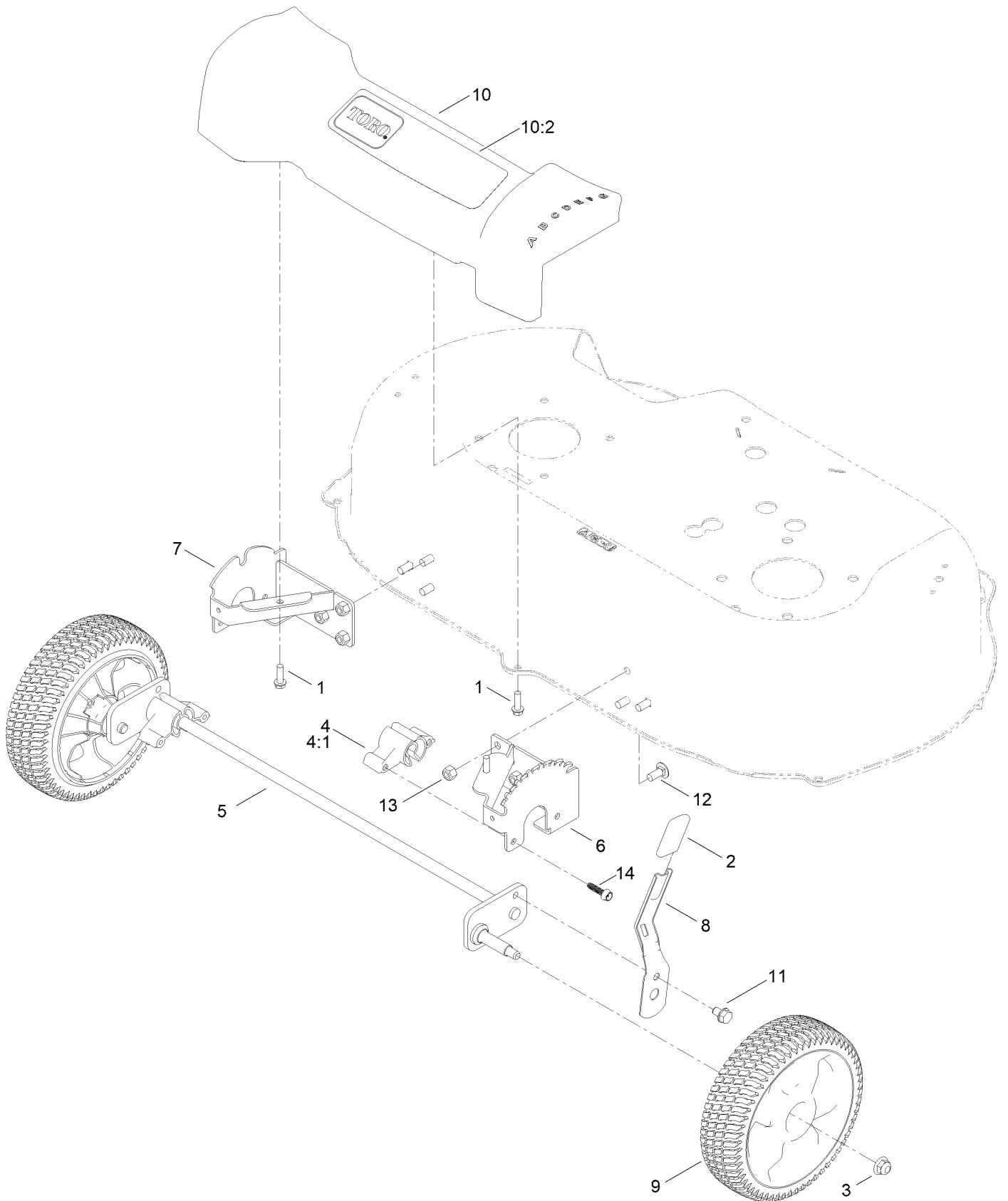

Front Wheel and Height-of-Cut Assembly (continued)

<i>Ref.</i>	<i>Part Number</i>	<i>Qty.</i>	<i>Description</i>	<i>Ref.</i>	<i>Part Number</i>	<i>Qty.</i>	<i>Description</i>
1	46-8091	3	Screw-HWH	8	120-7043	1	Arm-Spring
2	120-9535	1	Grip-Lever	9	125-2510	2	8 Inch Wheel ASM
3	119-4042	2	Nut-HF, NI	10	125-5027	1	Front Cover ASM
4	147-0519	2	Bushing-Pivot, Front	10:2	120-7047	1	Artwork-Toro Timemaster
4:1	15-4318	1	Resin-Nylon 66	11	700057	1	Screw-HWH
5	139-1753	1	Front Axle ASM	12	3230-23	6	Bolt-CARR
6	120-7037-03	1	Plate-HOC, LH	13	3296-29	6	Nut-Lock, NI
7	120-7038-03	1	Plate-HOC, RH	14	130-6658	4	Screw-Flange, Plastic

Rear Wheel and Height-of-Cut Assembly

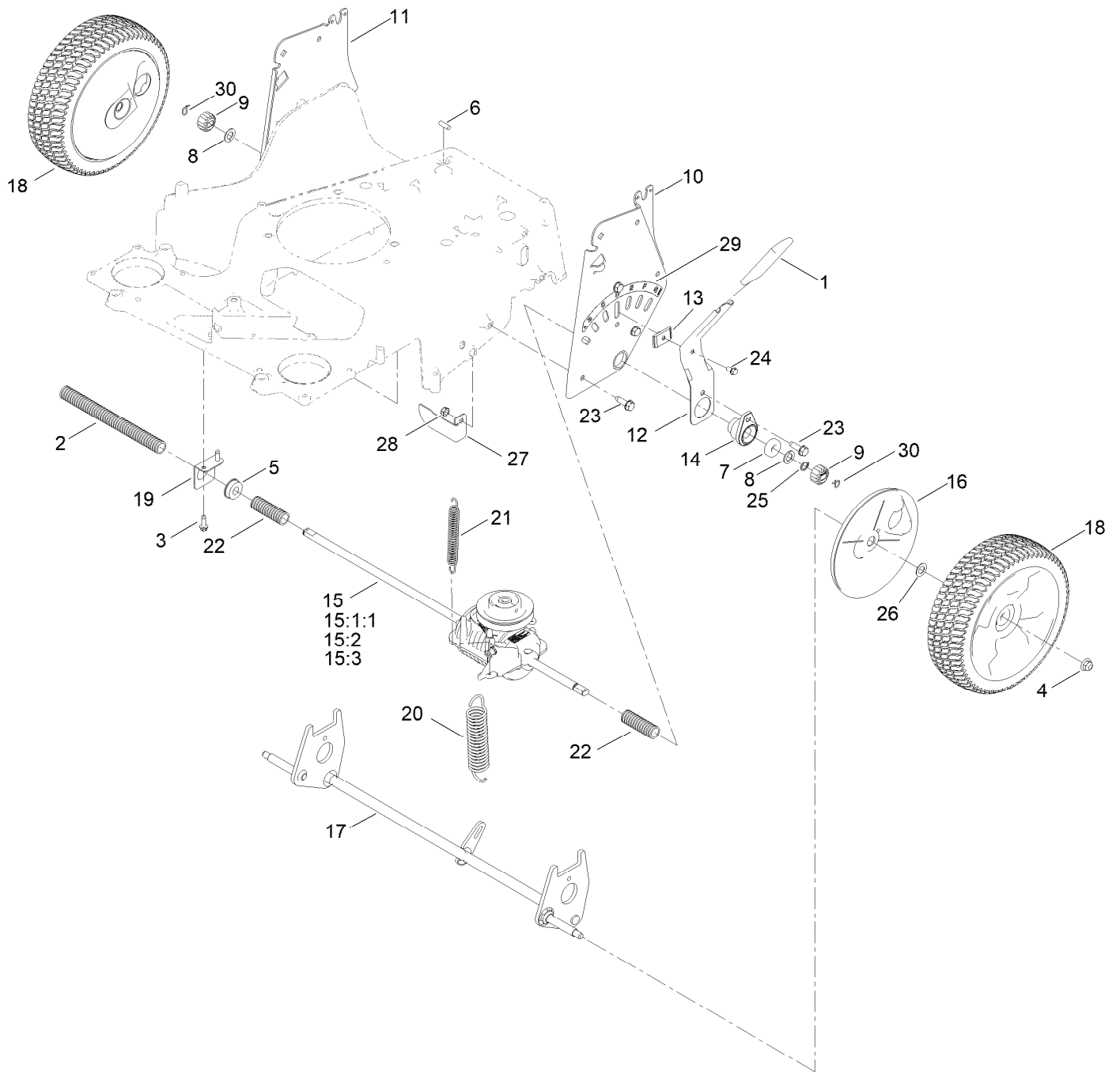

Rear Wheel and Height-of-Cut Assembly (continued)

<i>Ref.</i>	<i>Part Number</i>	<i>Qty.</i>	<i>Description</i>	<i>Ref.</i>	<i>Part Number</i>	<i>Qty.</i>	<i>Description</i>
1	137-4796	1	Grip-Lever, Lift	15:3	32151-61	1	Ring-Retaining
2	121-5799	1	Conduit-Convolute	16	120-6233	2	Cover-Gear
3	49-2040	2	Screw-HWHTF	17	139-1747	1	Rear Axle ASM
4	119-4042	2	Nut-HF, NI	18	125-2509	2	10 Inch Wheel Gear ASM
5	104-8699	1	Bearing-Ball	19	138-3233	1	Mount-Bearing
6	106-5681	1	Pin-Stop	20	120-7026	1	Spring-Extension
7	133-2603	2	Bearing-Ball	21	120-7027	1	Spring-Extension
8	110-7191	2	Washer-Thrust	22	121-5800	2	Conduit-Convolute
9	131-5399	2	Gear-Pinion, 15T	23	701243	8	Screw-Thd Roll, HWH
10	120-3342-03	1	Plate-HOC, LH	24	32144-4	1	Screw-HWH
11	120-3343-03	1	Plate-HOC, RH	25	32151-61	1	Ring-Retaining
12	137-9124	1	Arm-Spring	26	36-4780	2	Washer-Plain
13	120-5209	1	Key-Arm, Spring	27	138-5338	1	Bracket-Stop
14	136-5929	2	Retainer-Bearing	28	3296-47	1	Nut-Lock,NI
15	131-9665	1	Transmission Kit	29	125-2497	1	Decal-HOC, Rear
15:1:1	130-2370	1	Transmission Pulley Kit	30	130-2369	2	Pin-Snap
15:2	130-2369	2	Pin-Snap				

Handle Assembly

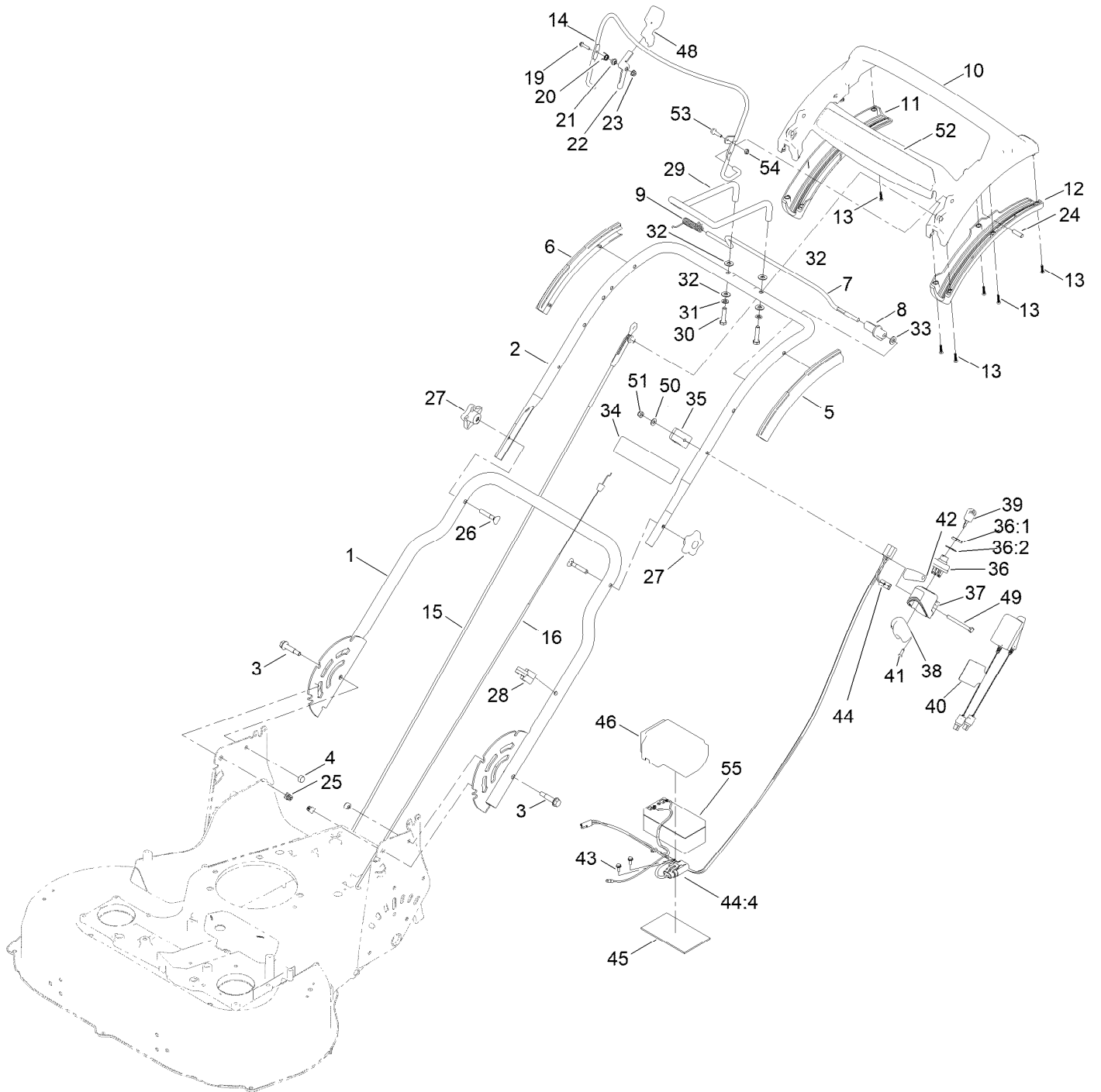

Handle Assembly (continued)

<i>Ref.</i>	<i>Part Number</i>	<i>Qty.</i>	<i>Description</i>	<i>Ref.</i>	<i>Part Number</i>	<i>Qty.</i>	<i>Description</i>
1	145-4021-05	1	Handle-Lower, ASM	30	137-3051	2	Screw-HH
2	145-4004-05	1	Handle-Upper	31	136-8682	2	Washer-Lock
3	139-1694	2	Bolt-Shoulder, HHF	32	107-0279	4	Washer
4	3296-29	2	Nut-Lock, NI	33	120-9683	1	Washer-Plain
5	140-2367	1	Guide-Curved, LH (Rwd)	34	140-4357	1	Decal-Battery Charging
6	140-2366	1	Guide-Curved, RH (Rwd)	35	136-5912	1	Anchor-Cable
7	139-5464	1	Rod-Control, Traction	36	23-0660	1	Switch-Starter
8	139-6554	1	Lever-Traction, Rwd	36:1	218-461	1	Nut-HH
9	140-4194	1	Spring-Torsion	36:2	3254-5	1	Washer-Lock
10	139-6569	1	Handle-Personal Pace, Curved	37	108-3795	1	Housing-Switch, Key
11	139-6567	1	Bottom-Handle, RH	38	108-3796	1	Cover-Swch
12	139-6568	1	Bottom-Handle, LH	39	700918	1	Key
13	94-4496	10	Screw-PPH	40	136-9126	1	Charger, Battery (12V)
14	147-0505-03	1	Bail-Brake [black]	41	139-1703	2	Screw-Plastic, PPH
15	161-3177	1	Cable-Brake	42	108-9751	1	Decal-Switch, Ignition
16	145-4007	1	Cable-Traction	43	32144-1	1	Screw-Taptite
19	106-9169	1	Screw-HWH	44	136-5895	1	Harness-Wire
20	107-7462	1	Spring-Torsion	44:4	99-6124	1	Fuse-40 Amp
21	107-7463	1	Spacer	45	108-0987	1	Foam-Battery
22	144-3174	1	Lever	46	120-3329	1	Cover-Battery
23	32128-17	1	Nut-Lock, Flange	48	112-8884	1	Knob
24	139-6577	2	Pin-Handle, Pp	49	321-57	1	Screw-HH
25	132-4516	2	Plug-Square	50	3256-1	1	Washer-Flat
26	137-3107	2	Screw-Handle	51	3296-73	1	Nut-Lock, NI
27	117-5976	2	Knob-Handle	52	145-5601	1	Decal-Handle, Pp
28	114-7988	1	Guide-Cable	53	139-1709	1	Screw-Shoulder
29	144-0249	1	Handle-Assist, Steel	54	137-3085	1	Nut-Hex
				55	106-8397	1	Battery-Wet

Attachments and Accessories

For 21220 TimeMaster 30in Lawn Mower

Product Name	Model/Part
Fuel Stabilizer .05 oz	130-2393
Engine Maintenance Kit.....	130-8146
4-Cycle Fuel, Snow And Lawn 32oz Can	131-3823
Toro Premium Fuel Treatment 12oz Bottle.....	131-6572
Oil-30/10W-30 Synthetic (Quart).....	138-6053
Traction Assist Handle Kit.....	144-6377
Hi-Lift Replacement Blade Kit.....	20122P
Lawn Striping Kit with 30in Roller.....	20602
Toro 4-Cycle SAE 30 Oil (32oz Bottle)	38903
Summer Oil-Case of 24 (20oz Bottles).....	38916
Bag-Walk Behind (Toro).....	490-7318
Mower Cover	490-7461

For 21220 TimeMaster 30in Lawn Mower

Product Name	Model/Part
Fuel Stabilizer .05 oz	130-2393
Engine Maintenance Kit.....	130-8146
4-Cycle Fuel, Snow And Lawn 32oz Can	131-3823
Toro Premium Fuel Treatment 12oz Bottle.....	131-6572
Oil-30/10W-30 Synthetic (Quart).....	138-6053
Traction Assist Handle Kit.....	144-6377
Hi-Lift Replacement Blade Kit.....	20122P
Lawn Striping Kit with 30in Roller.....	20602
Toro 4-Cycle SAE 30 Oil (32oz Bottle)	38903
Summer Oil-Case of 24 (20oz Bottles).....	38916
Bag-Walk Behind (Toro).....	490-7318
Mower Cover	490-7461

Notes:

Notes:

Notes:



Count on it.