



**Count on it.**

**Parts Catalog**

**21in Super Recycler®**

**Lawn Mower**

Model No. 21565—Serial No. 400000000 and Up



# Ordering Replacement Parts

To order replacement parts, please supply the part number, the quantity, and the description of each part desired.

## Understanding Reference Numbers

Each identified part in an illustration has a reference number. The reference number for a part also appears in the parts list, along with other information about the part.

This catalog uses two special reference number formats, one to indicate parts in a service assembly and another to indicate the quantity of a given part in an illustration.

## Service Assembly Reference Numbers

Parts in service assemblies have reference numbers in the form a:b. The a represents the reference number of the entire service assembly and the b represents a sequential number unique to each part within the service assembly.

For example, a wheel assembly might be identified by reference number 6, the tire by 6:1, the valve by 6:2, and the wheel by 6:3. When you order the assembly identified by reference number 6, you receive all parts identified by reference numbers 6:1, 6:2, and 6:3. However, you may also order any part individually. Reference numbers of this type appear in illustration and in parts lists.

## Reference Numbers Indicating Quantity

In an illustration, if a reference number indicates more than one part, the reference number has the form nX y. The n represents the quantity of the part, the X is the multiplication symbol, and the y represents the reference number.

For example, in an illustration, the reference number 2X 37 means that two of the parts identified by reference number 37 are indicated.

# Contents

Housing Assembly .....	4
Rear Bag Assembly .....	6
Deck Decal Assembly .....	8
Engine and Blade Assembly .....	10
Front Wheel and Height-of-Cut Assembly .....	12
Rear Wheel and Height-of-Cut Assembly .....	14
Handle Assembly .....	16
Attachments and Accessories .....	18

# Housing Assembly

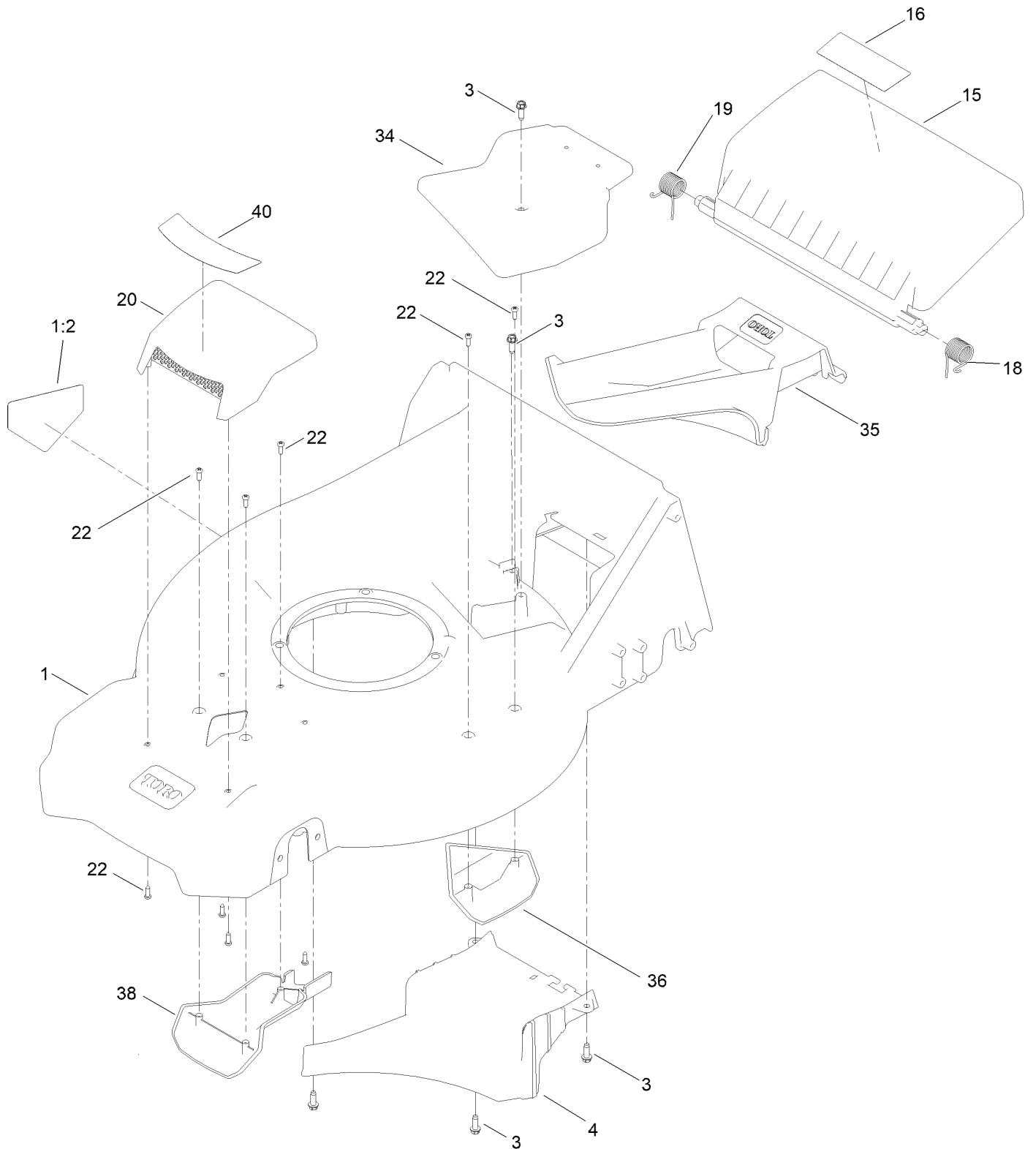

## Housing Assembly (continued)

<i>Ref.</i>	<i>Part Number</i>	<i>Qty.</i>	<i>Description</i>	<i>Ref.</i>	<i>Part Number</i>	<i>Qty.</i>	<i>Description</i>
1	145-5835	1	Housing ASM	20	144-6531	1	ASM-Cover, Top Intake
1:2	94-8072	1	Decal-Danger	22	139-1703	9	Screw-Plastic, PPH
3	49-2040	5	Screw-HWHTF	34	144-0234	1	Cover-Belt, Top
4	144-0233	1	Ramp-Discharge	35	144-0236	1	Plug-Mulch
15	139-5477	1	Door-Rear	36	144-0237	1	Kicker-Housing
16	131-4514	1	Decal-Warning	38	144-6464	1	Cover-Intake, Bottom
18	139-5478	1	Spring-Torsion, LH	40	145-5600	1	Decal-Cover, Intake
19	139-5479	1	Spring-Torsion, RH				

# Rear Bag Assembly

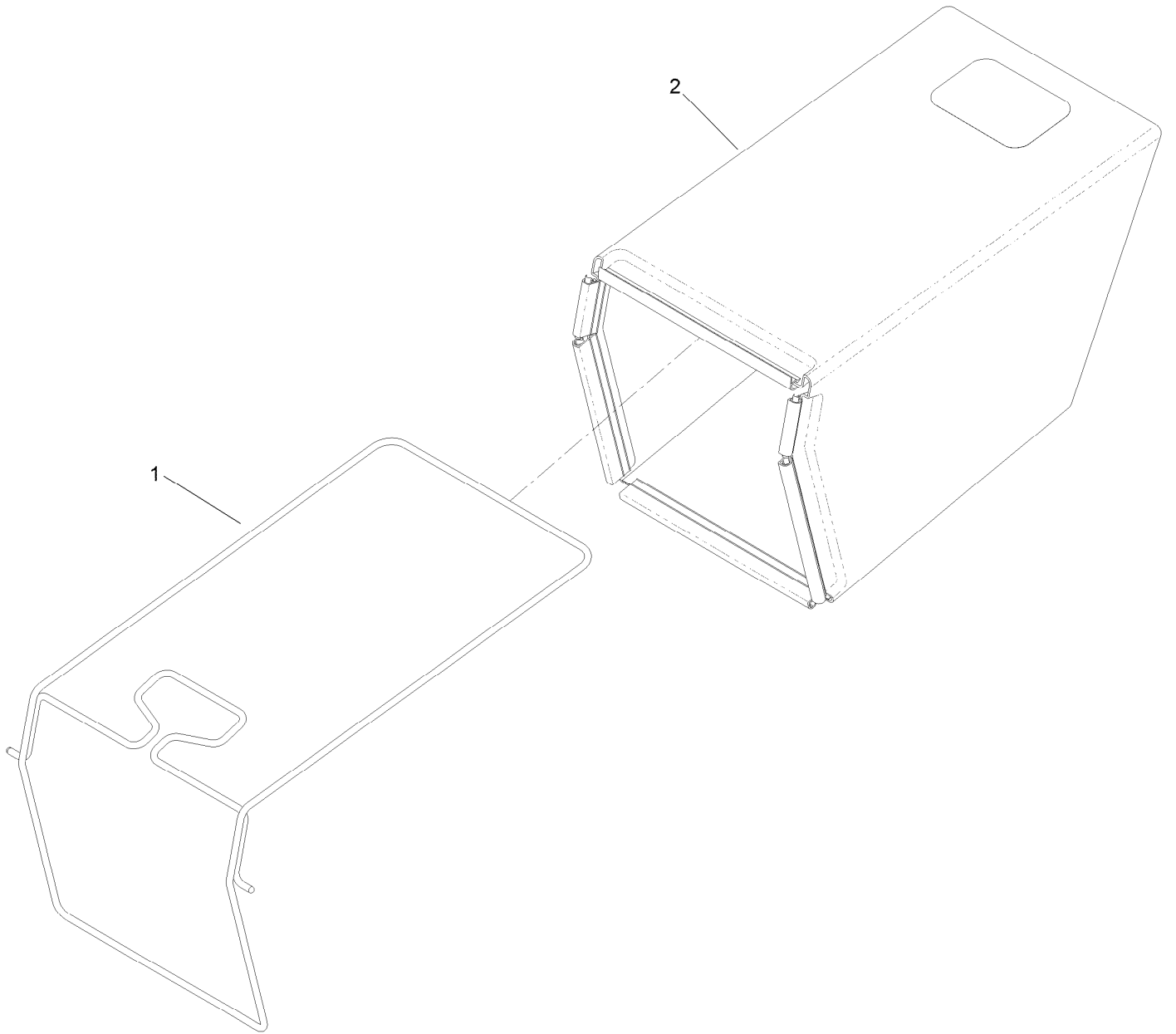

## Rear Bag Assembly (continued)

<i>Ref.</i>	<i>Part Number</i>	<i>Qty.</i>	<i>Description</i>
1	139-5470-03	1	ASM-Frame, Bag
2	144-6509	1	ASM-Bag, Grass

# Deck Decal Assembly

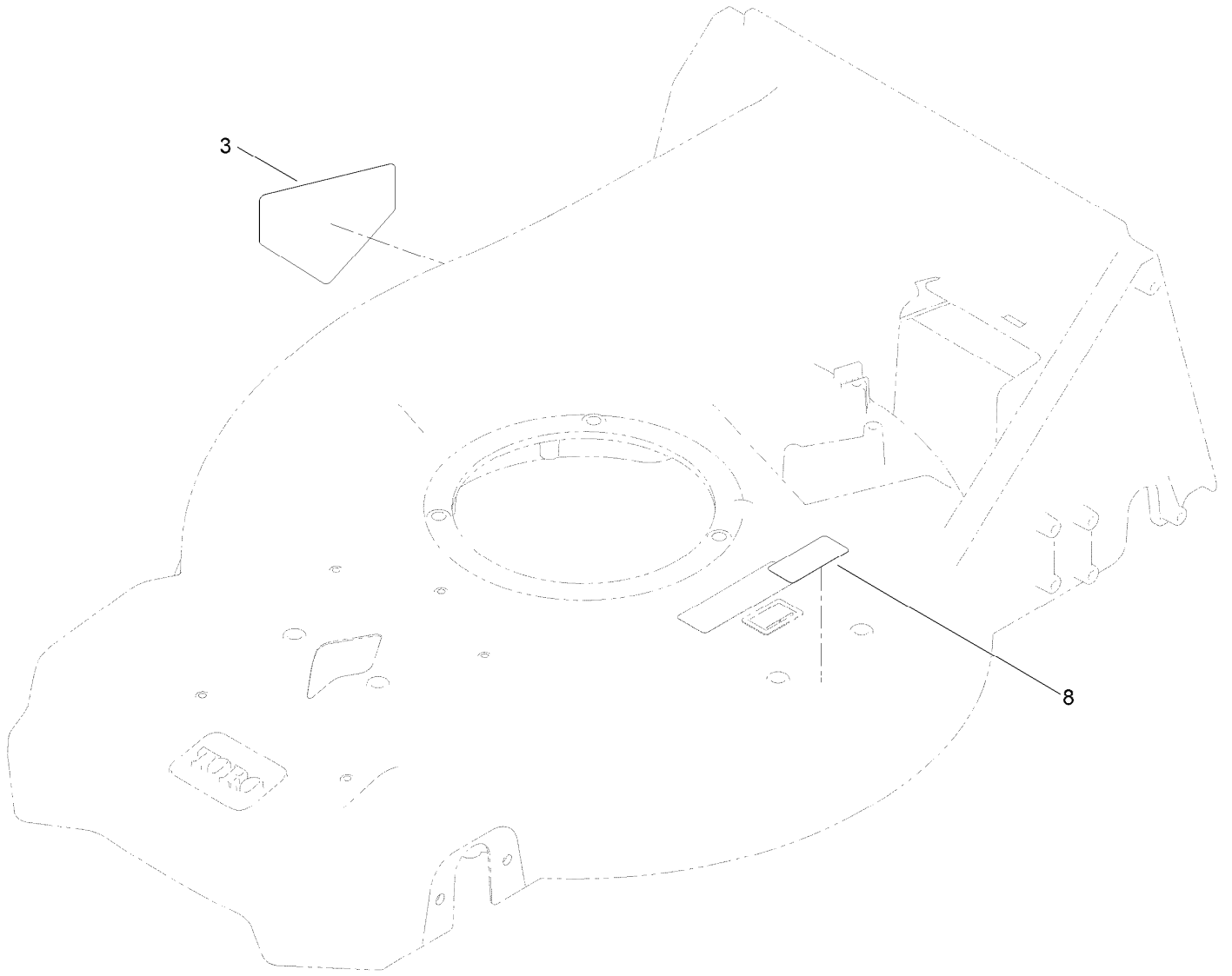



## Deck Decal Assembly (continued)

<i>Ref.</i>	<i>Part Number</i>	<i>Qty.</i>	<i>Description</i>
3	94-8072	1	Decal-Danger
8	121-5684	1	Decal-Location, Service Dealer

# Engine and Blade Assembly

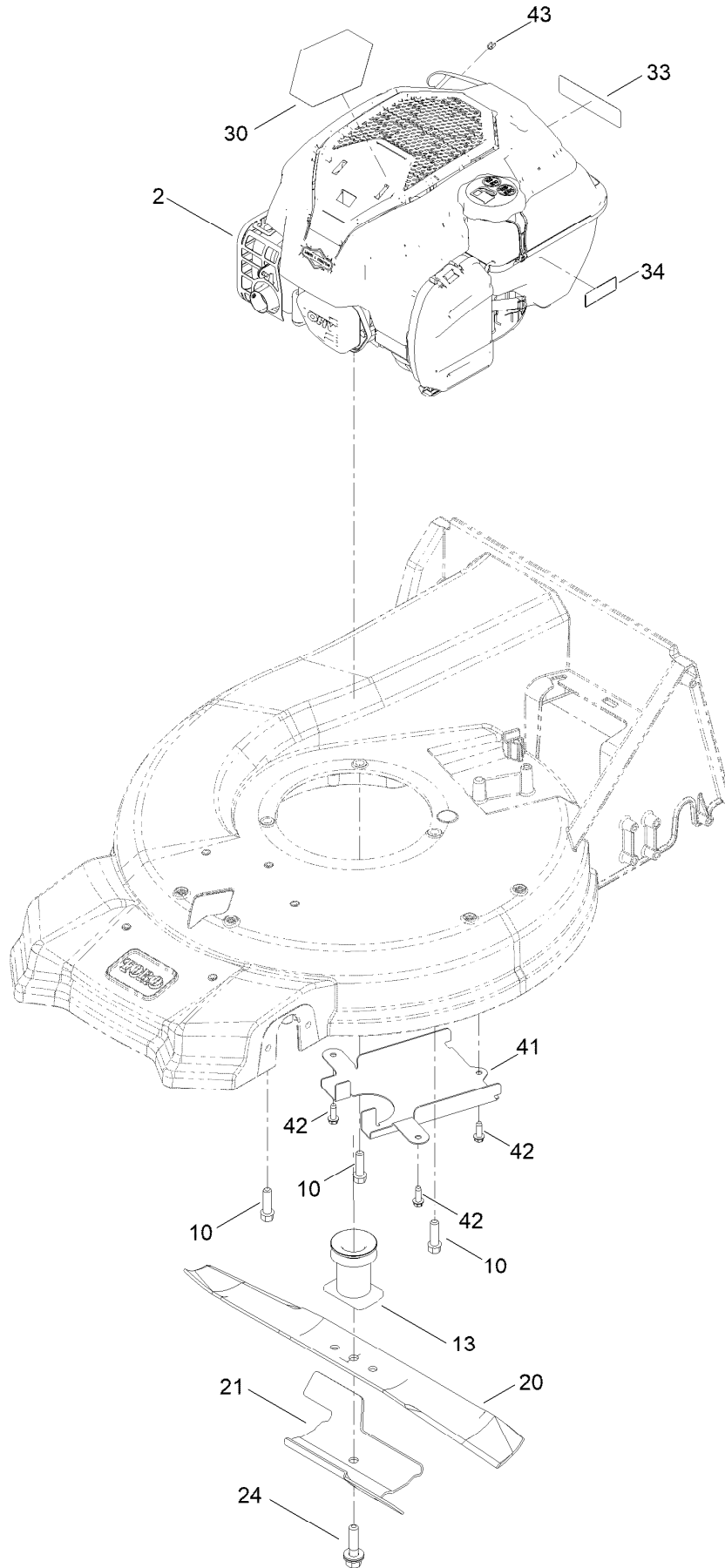

## Engine and Blade Assembly (continued)

<i>Ref.</i>	<i>Part Number</i>	<i>Qty.</i>	<i>Description</i>	<i>Ref.</i>	<i>Part Number</i>	<i>Qty.</i>	<i>Description</i>
2		1	Engine-Briggs 104M020254F1 ●■	24	125-2466	1	Bolt-Blade
10	95-1727	3	Screw-Taptite	30	145-5603	1	Decal-Briggs 725 Exi SS
13	139-1816	1	Driver-Blade	33	133-8062	1	Decal-Spark Arrestor
20	133-8183-03	1	Blade-Recycling 21In (Bagging)	34	133-8198	1	Decal-Level, Fuel
21	105-6848-01	1	Accelerator-Blade	41	144-0238-03	1	Cover-Belt, Bottom
				42	49-2040	3	Screw-HWHTF
				43	2210-316	1	Stop-Rope

● Not serviced separately

■ Obtain parts from [www.briggsandstratton.com](http://www.briggsandstratton.com)

# Front Wheel and Height-of-Cut Assembly

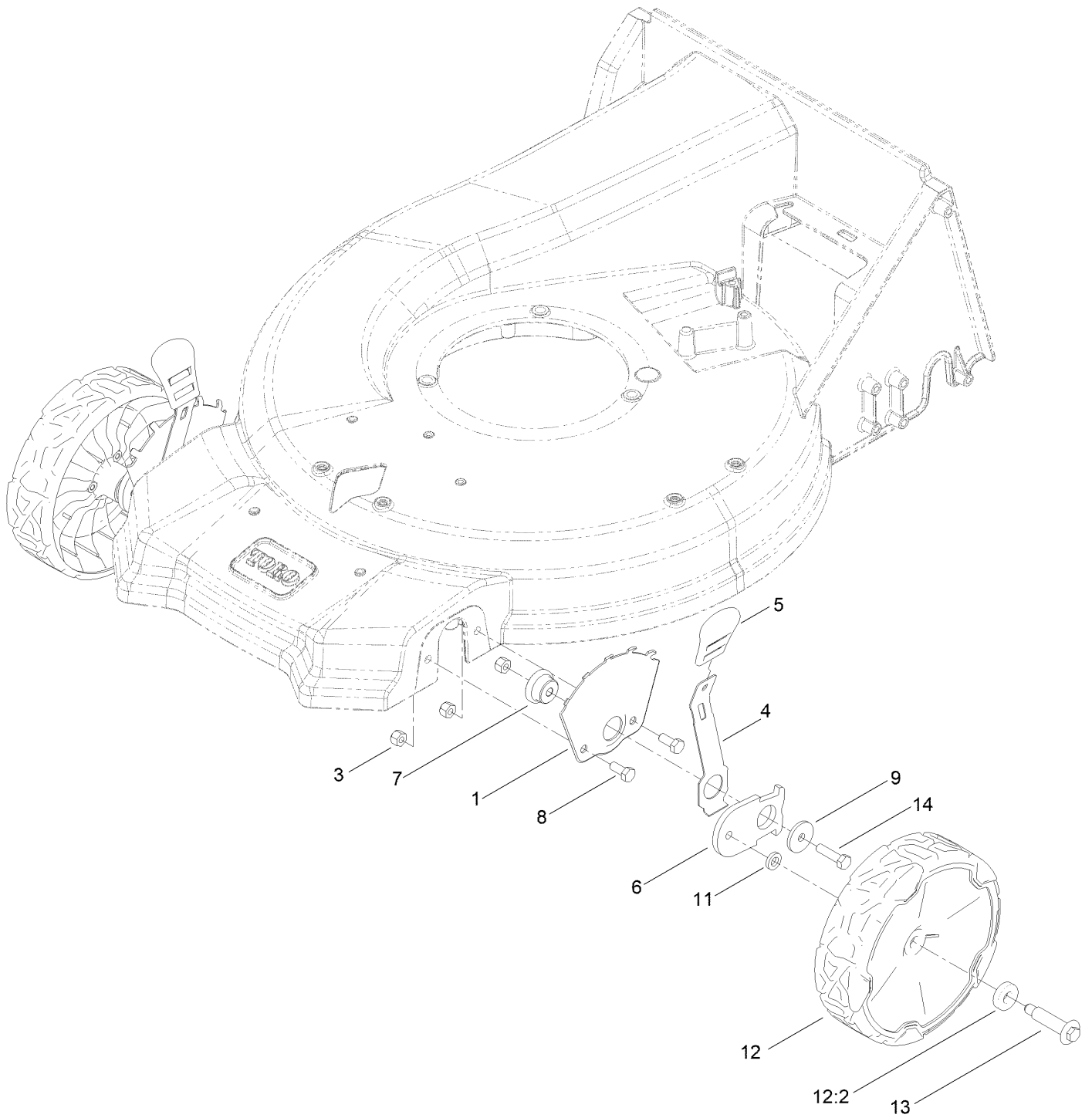

## Front Wheel and Height-of-Cut Assembly (continued)

<i>Ref.</i>	<i>Part Number</i>	<i>Qty.</i>	<i>Description</i>	<i>Ref.</i>	<i>Part Number</i>	<i>Qty.</i>	<i>Description</i>
1	115-1956-05	2	Plate-HOC,Front Fsvq	9	139-1704	2	Washer-Flat
3	119-4038	6	Nut-Hex	11	139-5449	2	Washer-Wheel Bolt
4	105-1809	2	Arm-Spring	12	144-6469	2	ASM-Wheel, 8" (Bearings)
5	110-0549	2	Knob-HOC	12:2	52-2450	2	Bearing-Wheel
6	137-9128	2	Arm-Pivot, Front	13	614650	2	Bolt-Shoulder
7	105-1818	2	Bushing-Mount, HOC	14	120-9696	2	Screw-HH
8	137-3052	4	Screw-HH				

# Rear Wheel and Height-of-Cut Assembly

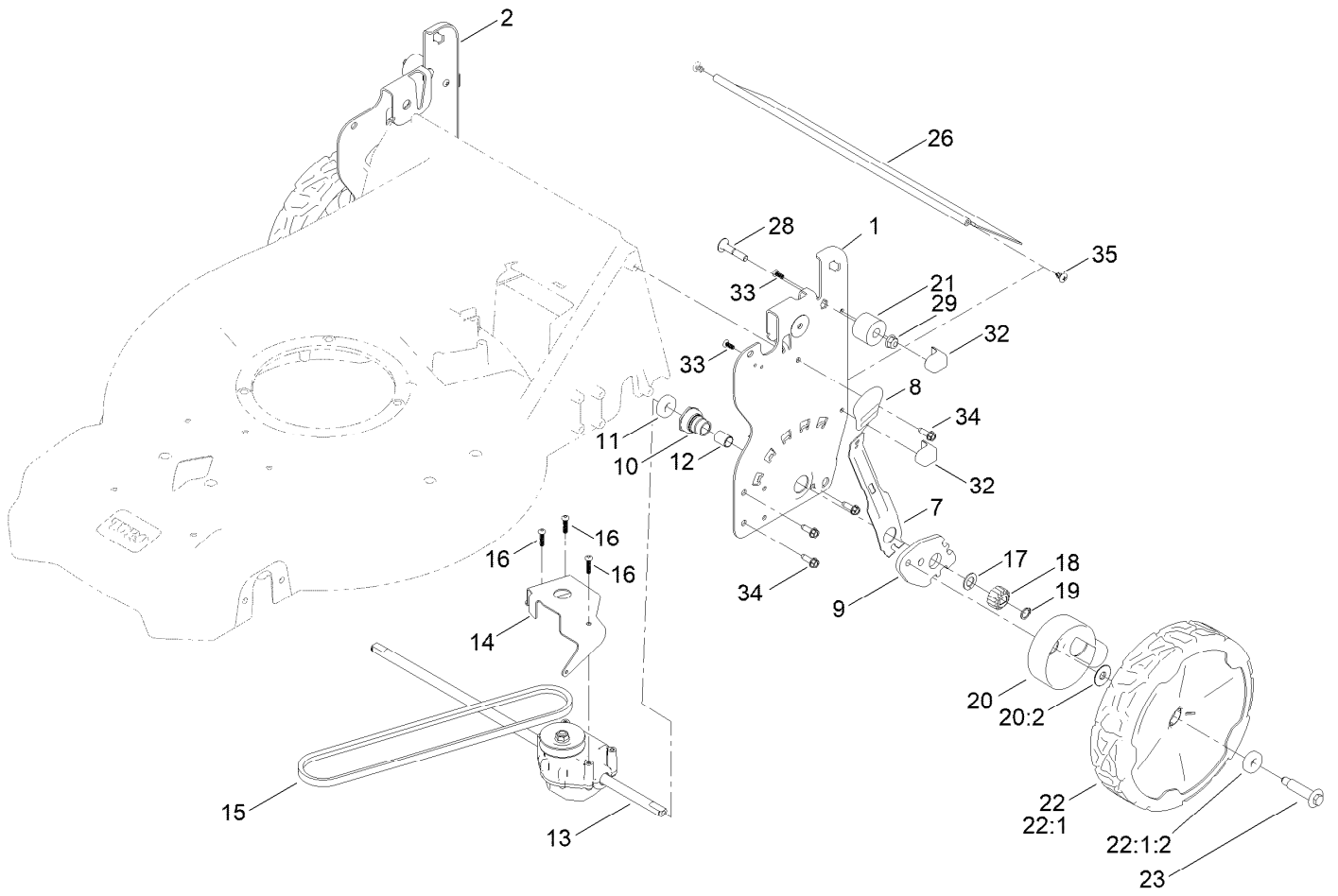

## Rear Wheel and Height-of-Cut Assembly (continued)

<i>Ref.</i>	<i>Part Number</i>	<i>Qty.</i>	<i>Description</i>	<i>Ref.</i>	<i>Part Number</i>	<i>Qty.</i>	<i>Description</i>
1	144-6523-05	1	Plate-HOC, LH (Non-SS)	20	144-0240	2	ASM-Cover, Gear
2	144-6522-05	1	Plate-HOC, RH (Non-SS)	20:2	614426	1	Washer-Stepped
7	132-4486	2	Arm-Spring	21	144-0218	2	Bumper-Isolator
8	110-0549	2	Knob-HOC	22	144-6474	2	ASM-9.65" Wheel, Geared
9	139-5451	2	Arm-Pivot, Rear	22:1		1	ASM-Wheel, 9.65" (Bearings) ● ■
10	108-9779	2	Retainer-Bushing, HOC	22:1:2	52-2450	2	Bearing-Wheel
11	52-2450	2	Bearing-Wheel	23	139-1789	2	Wheel Bolt
12	108-9782	2	Bushing-Sleeve	26	139-6597	1	Shield-Trailing
13	144-0248	1	Transmission-Rwd, 5.25:1	28	322-7	2	Screw-HH
14	132-4481-03	1	Bracket-Trans, Rwd Hi	29	32128-20	2	Nut-HF
15	115-4669	1	Belt-V	32	140-2369	4	Pad-Smart Stow
16	108-7476	3	Screw-Plastite	33	107-7461	4	Screw-Plastite
17	110-7191	2	Washer-Thrust	34	49-2040	8	Screw-HWHTF
18	131-5399	2	Gear-Pinion, 15T	35	117-1092	2	Screw-PTH
19	32151-61	2	Ring-Retaining				

● Not illustrated

■ Not serviced separately

# Handle Assembly

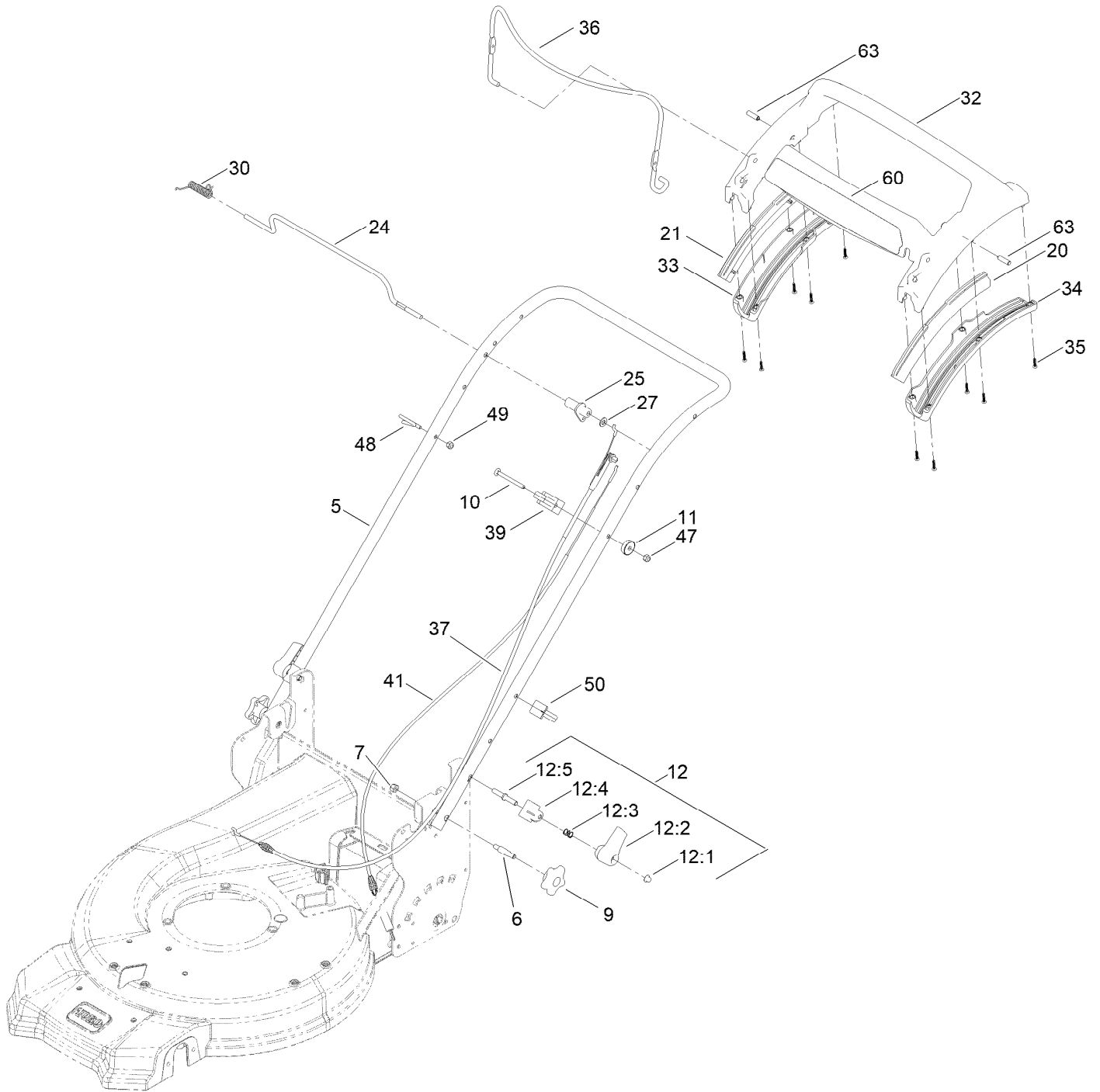



## Handle Assembly (continued)

<i>Ref.</i>	<i>Part Number</i>	<i>Qty.</i>	<i>Description</i>	<i>Ref.</i>	<i>Part Number</i>	<i>Qty.</i>	<i>Description</i>
5	144-6516-05	1	Handle-Curved	30	140-4194	1	Spring-Torsion
6	139-6588	2	Bolt-Shoulder, Handle	32	139-6569	1	Handle-Personal Pace, Curved
7	3296-29	2	Nut-Lock, NI	33	139-6567	1	Bottom-Handle, RH
9	117-5976	2	Knob-Handle	34	139-6568	1	Bottom-Handle, LH
10	144-0221	1	Screw-CARR	35	94-4496	10	Screw-PPH
11	136-9075	1	Washer-Curved	36	140-4023-03	1	Bail-Brake
12	138-3249	2	Quick Release ASM	37	139-6594	1	Cable-Brake, Pp B&s
12:1	140-4157	1	Nut-Push	39	139-6581	1	Anchor-Cable, Rwd
12:2	138-3248	1	Lever-Release	41	139-6595	1	Cable-Traction, Rwd (Pp)
12:3	138-3253	1	Anchor-Spring	47	3296-73	1	Nut-Lock, NI
12:4	115-2858	1	Spring-Compression	48	86-9671	1	Guide-Rope
12:5	140-4158	1	Rod-Release	49	137-3094	1	Nut-Hex
20	140-2367	1	Guide-Curved, LH (Rwd)	50	114-7988	1	Guide-Cable
21	140-2366	1	Guide-Curved, RH (Rwd)	60	145-5601	1	Decal-Handle, Pp
24	139-5464	1	Rod-Control, Traction	63	139-6577	2	Pin-Handle, Pp
25	139-6554	1	Lever-Traction, Rwd				
27	3256-23	1	Washer-Plain				

# Attachments and Accessories

## For 21565 21in Super Recycler Lawn Mower

<b>Product Name</b>	<b>Model/Part</b>
Bagging Blade .....	108-3759-03
Fuel Stabilizer .05 oz .....	130-2393
Briggs Maint Kit.....	130-8148
4-Cycle Fuel, Snow And Lawn 32oz Can .....	131-3823
Toro Premium Fuel Treatment 12oz Bottle.....	131-6572
Oil-30/10W-30 Synthetic (Quart).....	138-6053
Discharge Chute ASM .....	144-0242
Lawn Striping Kit with 22in Roller.....	20601
Summer Oil-Case of 24 (20oz Bottles).....	38916
Smart Stow Walk Power Mower Cover .....	490-2012
Bag-Walk Behind (Toro).....	490-7318
Lawnmower Cover.....	490-7462

**Notes:**



**Count on it.**