



Count on it.

Parts Catalog

**GrandStand® Revolution® Mower
with 132cm TURBO FORCE® Side Discharge
Cutting Unit**

Model No. 18850TE—Serial No. 414300000 and Up



Ordering Replacement Parts

To order replacement parts, please supply the part number, the quantity, and the description of each part desired.

Understanding Reference Numbers

Each identified part in an illustration has a reference number. The reference number for a part also appears in the parts list, along with other information about the part.

This catalog uses two special reference number formats, one to indicate parts in a service assembly and another to indicate the quantity of a given part in an illustration.

Service Assembly Reference Numbers

Parts in service assemblies have reference numbers in the form a:b. The a represents the reference number of the entire service assembly and the b represents a sequential number unique to each part within the service assembly.

For example, a wheel assembly might be identified by reference number 6, the tire by 6:1, the valve by 6:2, and the wheel by 6:3. When you order the assembly identified by reference number 6, you receive all parts identified by reference numbers 6:1, 6:2, and 6:3. However, you may also order any part individually. Reference numbers of this type appear in illustration and in parts lists.

Reference Numbers Indicating Quantity

In an illustration, if a reference number indicates more than one part, the reference number has the form nX y. The n represents the quantity of the part, the X is the multiplication symbol, and the y represents the reference number.

For example, in an illustration, the reference number 2X 37 means that two of the parts identified by reference number 37 are indicated.

Contents

52 Inch Deck Assembly	4
Deck Decal Assembly No. 144-6930	6
Deflector Assembly No. 147-1642	8
Ground Drive Assembly	10
Motion Control Assembly	12
LH Control Handle Assembly No. 144-1421	14
RH Control Handle Assembly No. 144-1422	16
Cover Assembly	18
Deck Lift Assembly	20
HOC Pivot Assembly No. 144-1554	22
HOC Pivot Assembly No. 144-1555	24
HOC Level Assembly No. 130-1755	26
HOC Link Assembly No. 130-6615	28
Frame Assembly	30
Platform Assembly	32
Front Caster Assembly	34
Wheel and Bearing Assembly	36
Battery Assembly	38
Electrical Assembly	40
Battery Cable Assembly	42
Control Panel and Harness Assembly	44
Attachments and Accessories	46

52 Inch Deck Assembly

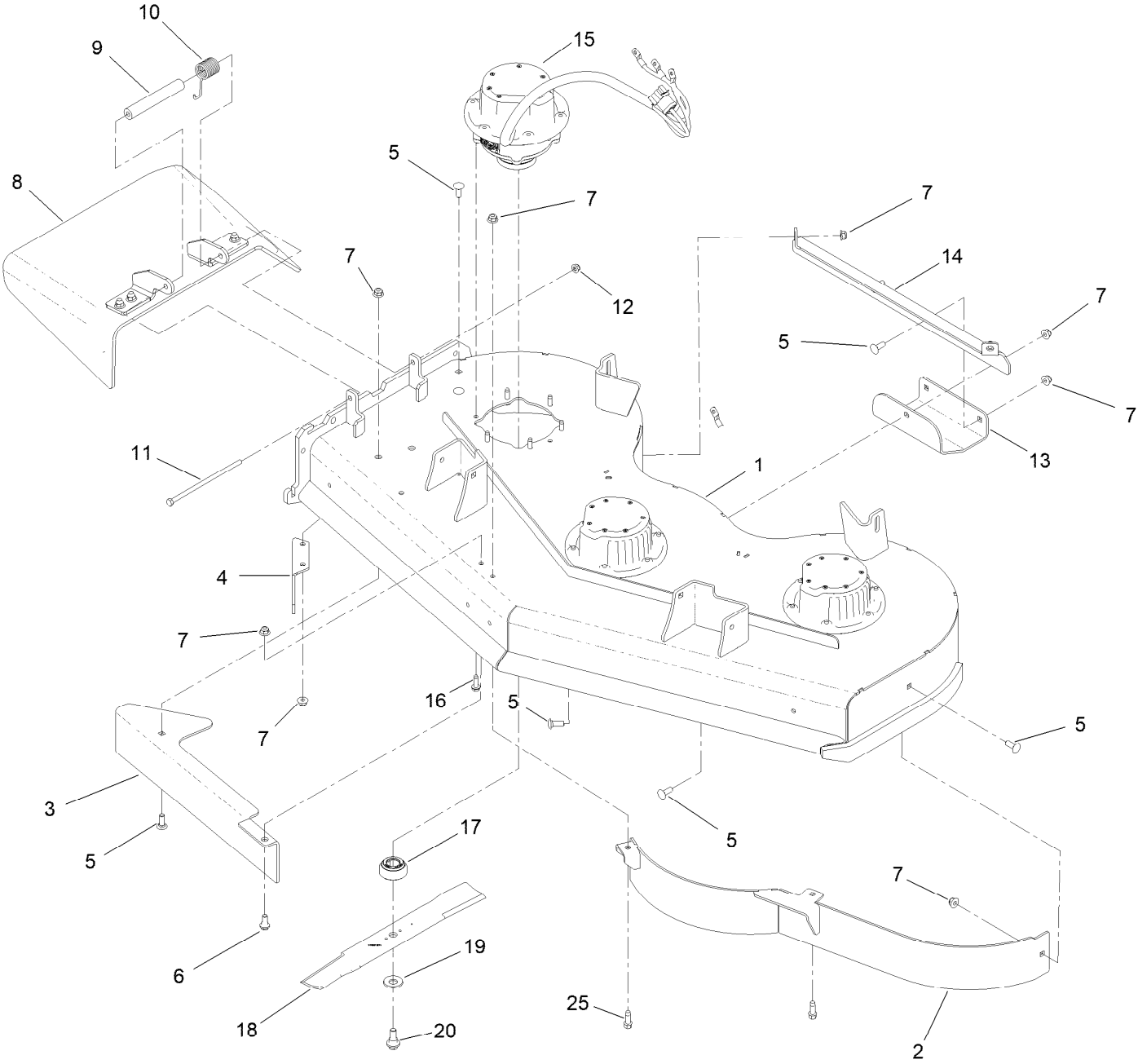

52 Inch Deck Assembly (continued)

<i>Ref.</i>	<i>Part Number</i>	<i>Qty.</i>	<i>Description</i>	<i>Ref.</i>	<i>Part Number</i>	<i>Qty.</i>	<i>Description</i>
1	144-6930	1	Deck ASM, 52In	12	104-8300	1	Nut-HF, NI
2	144-3805-01	1	Baffle ASM, Front [red]	13	114-1908-01	1	Skid
3	139-8105-01	1	Plate-Baffle, Formed [red]	14	130-6648-01	1	Bracket-Skid
4	130-6594-01	1	Baffle-Discharge	15	147-1689	1	Motor/Gen
5	3231-22	9	Screw-CARR	16	701243	18	Screw-Thd Roll, HWH
6	94-7582	1	Bolt-Shoulder	17	145-3439	3	Retainer-Blade
7	104-8301	12	Nut-HF, NI	18	145-3504-03	3	Blade-18.0In, Med Sail
8	147-1642	1	Rubber Deflector ASM	19	125-1736	3	Washer-Belleville
9	105-4622	1	Spacer	20	145-3499	3	Screw-Shoulder, HWH
10	108-4052	1	Spring-Torsion	25	92-1624	2	Screw-HWH Thd Form
11	322-50	1	Screw-HH				

Deck Decal Assembly No. 144-6930

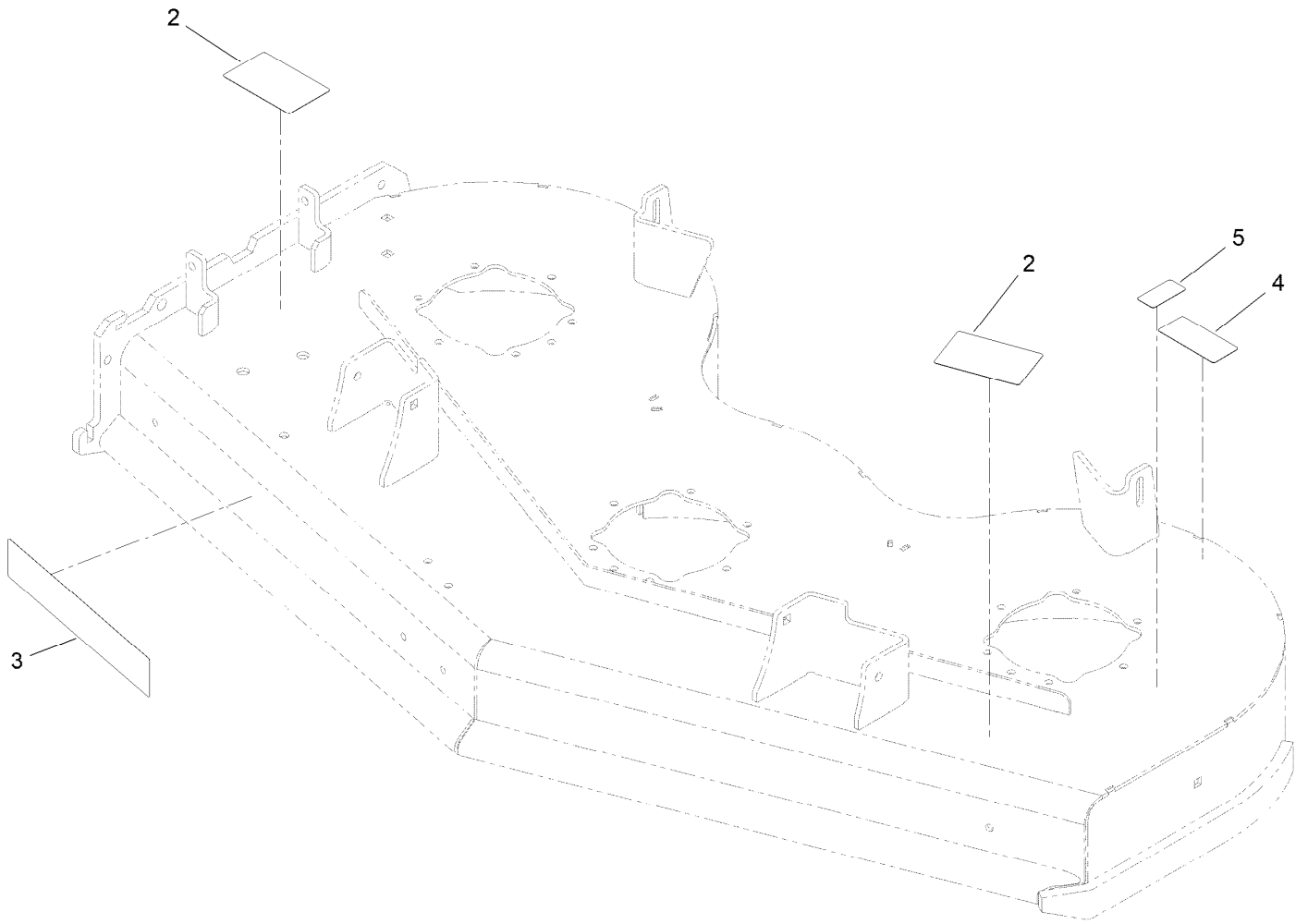

Deck Decal Assembly No. 144-6930 (continued)

<i>Ref.</i>	<i>Part Number</i>	<i>Qty.</i>	<i>Description</i>	<i>Ref.</i>	<i>Part Number</i>	<i>Qty.</i>	<i>Description</i>
2	144-7006	2	Decal-Danger, CE	4	147-0288	1	Decal-Danger
3	107-1618	1	Decal	5	137-8127	1	Decal-No Spray

Deflector Assembly No. 147-1642

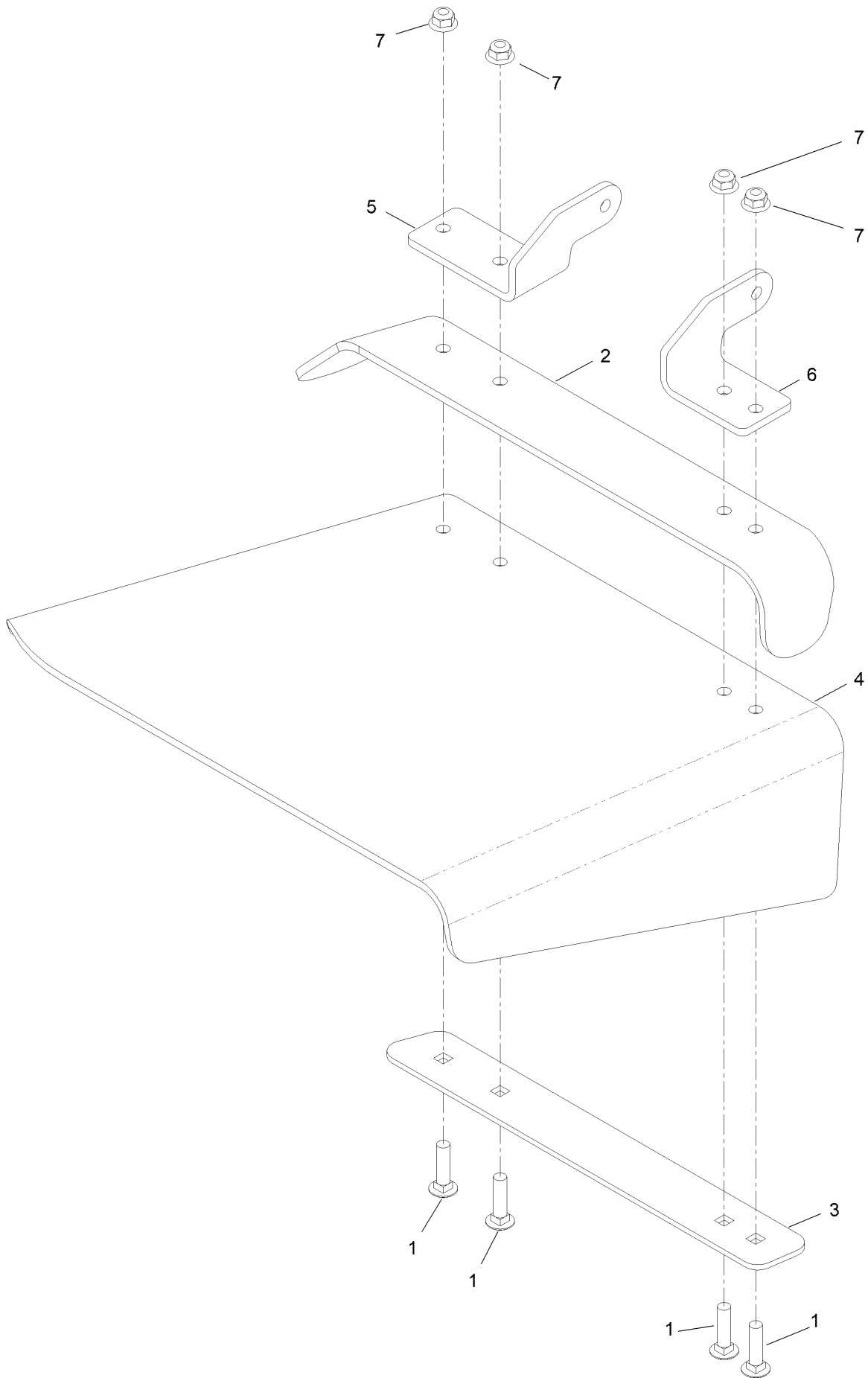

Deflector Assembly No. 147-1642 (continued)

<i>Ref.</i>	<i>Part Number</i>	<i>Qty.</i>	<i>Description</i>	<i>Ref.</i>	<i>Part Number</i>	<i>Qty.</i>	<i>Description</i>
1	3231-4	4	Screw-CARR	5	147-0386-01	1	Plate-Hinge, Rear
2	106-3246-01	1	Deflector	6	147-0387-01	1	Plate-Hinge, Front
3	106-3248-03	1	Strap-Discharge	7	104-8301	4	Nut-HF, NI
4	139-8114	1	Deflector-Deck, Rubber				

Ground Drive Assembly

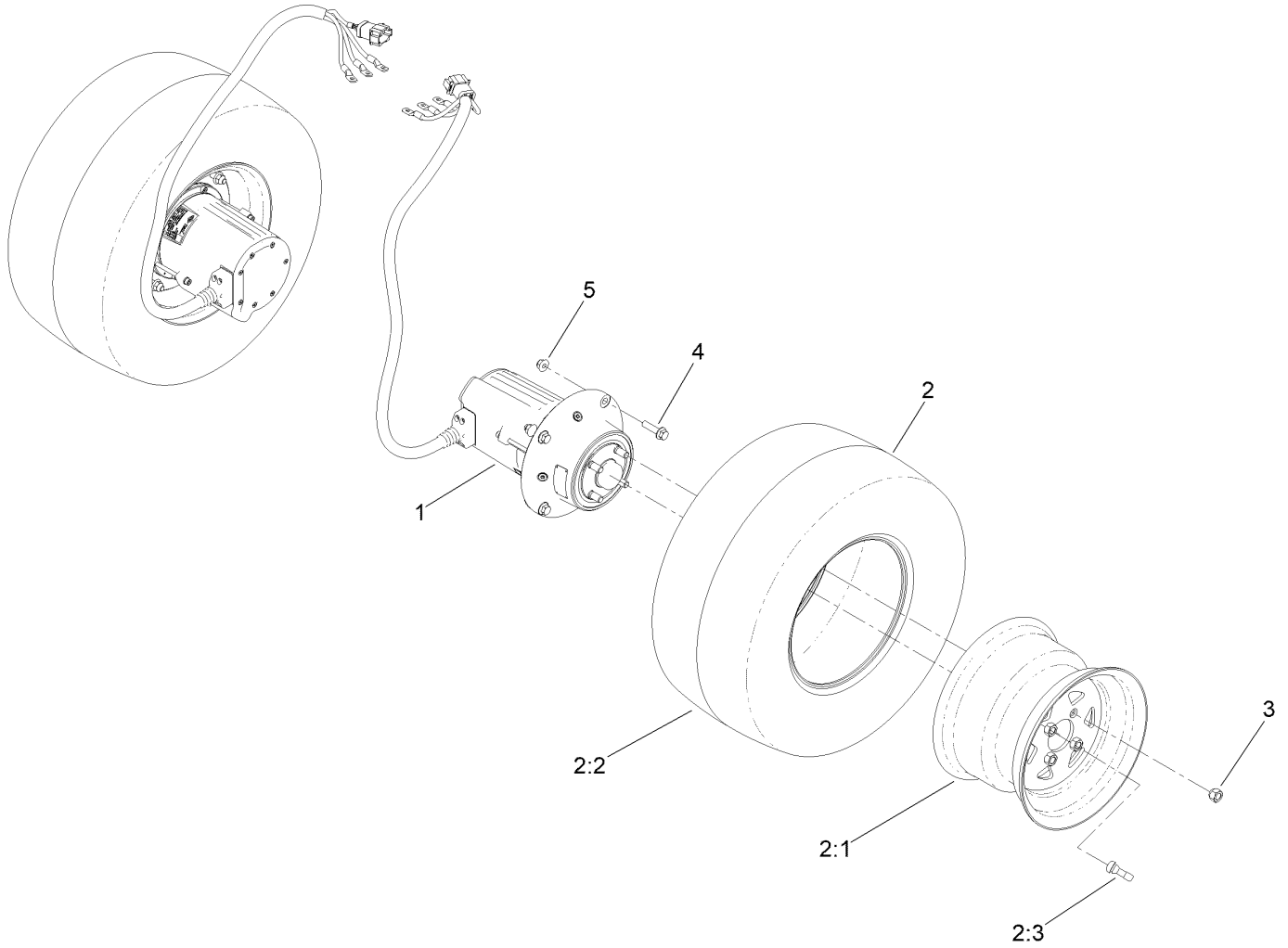

Ground Drive Assembly (continued)

<i>Ref.</i>	<i>Part Number</i>	<i>Qty.</i>	<i>Description</i>	<i>Ref.</i>	<i>Part Number</i>	<i>Qty.</i>	<i>Description</i>
1	147-1688	1	Motor/Gearbox ASM-48V,	2:3	232-27	1	Stem-Valve
2	144-3846	2	Wheel And Tire ASM	3	242-35	8	Nut-Wheel
2:1	144-3847	1	Rim-10 In	4	114-4681	8	Screw-HHF
2:2	144-1519	1	Tire	5	104-8301	8	Nut-HF, NI

Motion Control Assembly

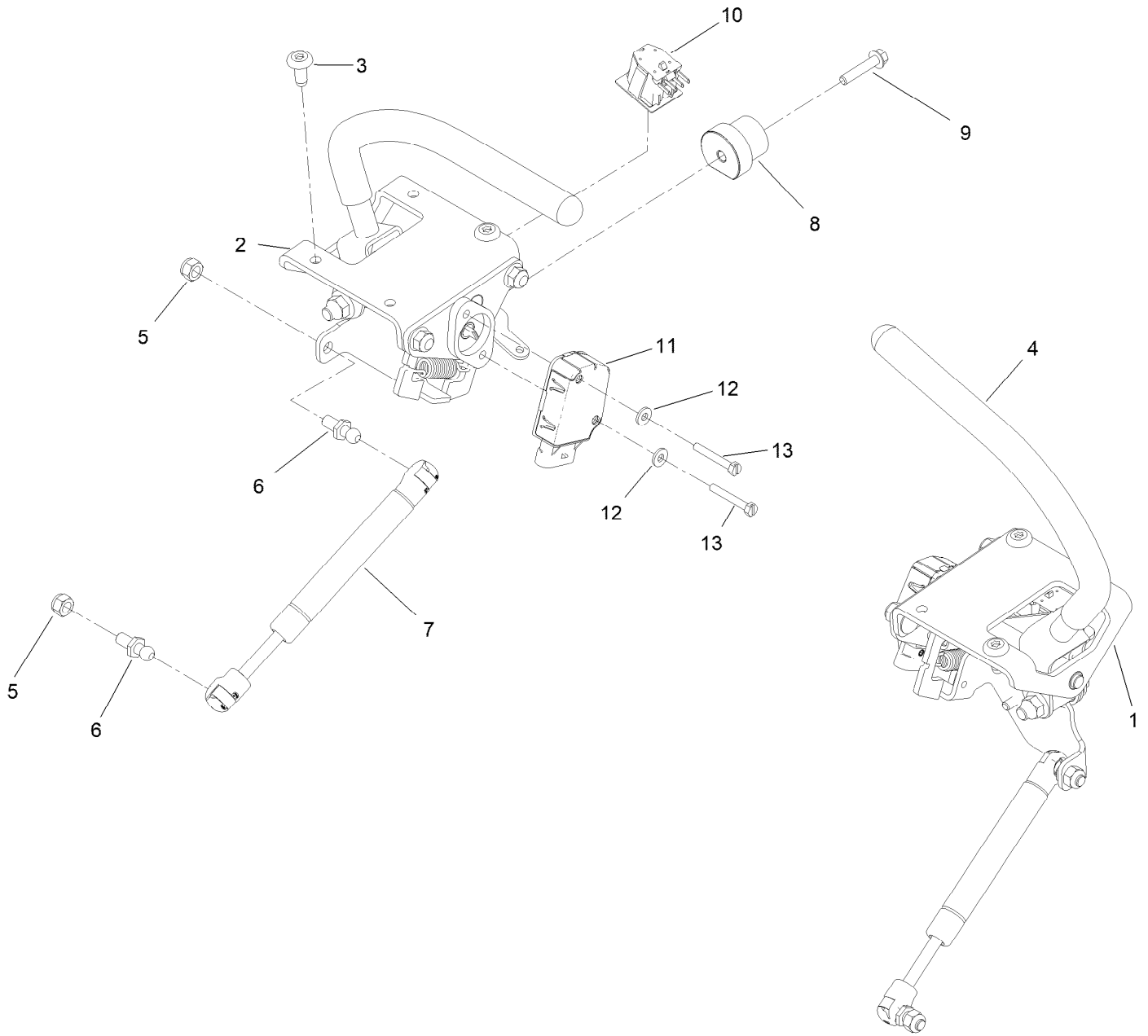

Motion Control Assembly (continued)

<i>Ref.</i>	<i>Part Number</i>	<i>Qty.</i>	<i>Description</i>	<i>Ref.</i>	<i>Part Number</i>	<i>Qty.</i>	<i>Description</i>
1	144-1421	1	Control Handle ASM, LH	8	126-1499	2	Cam
2	144-1422	1	Control Handle ASM, RH	9	32144-110	2	Screw-HWH
3	138-9753	4	Screw	10	145-3520	2	Switch-Plunger, On-(On)
4	119-0222	2	Grip	11	122-0917	2	Sensor-Position
5	138-8401	4	Nut-HF	12	3256-14	4	Washer-Flat
6	103-5752	4	Stud-Ball	13	32105-1	4	Screw-SHH
7	139-1523	2	Damper				

LH Control Handle Assembly No. 144-1421

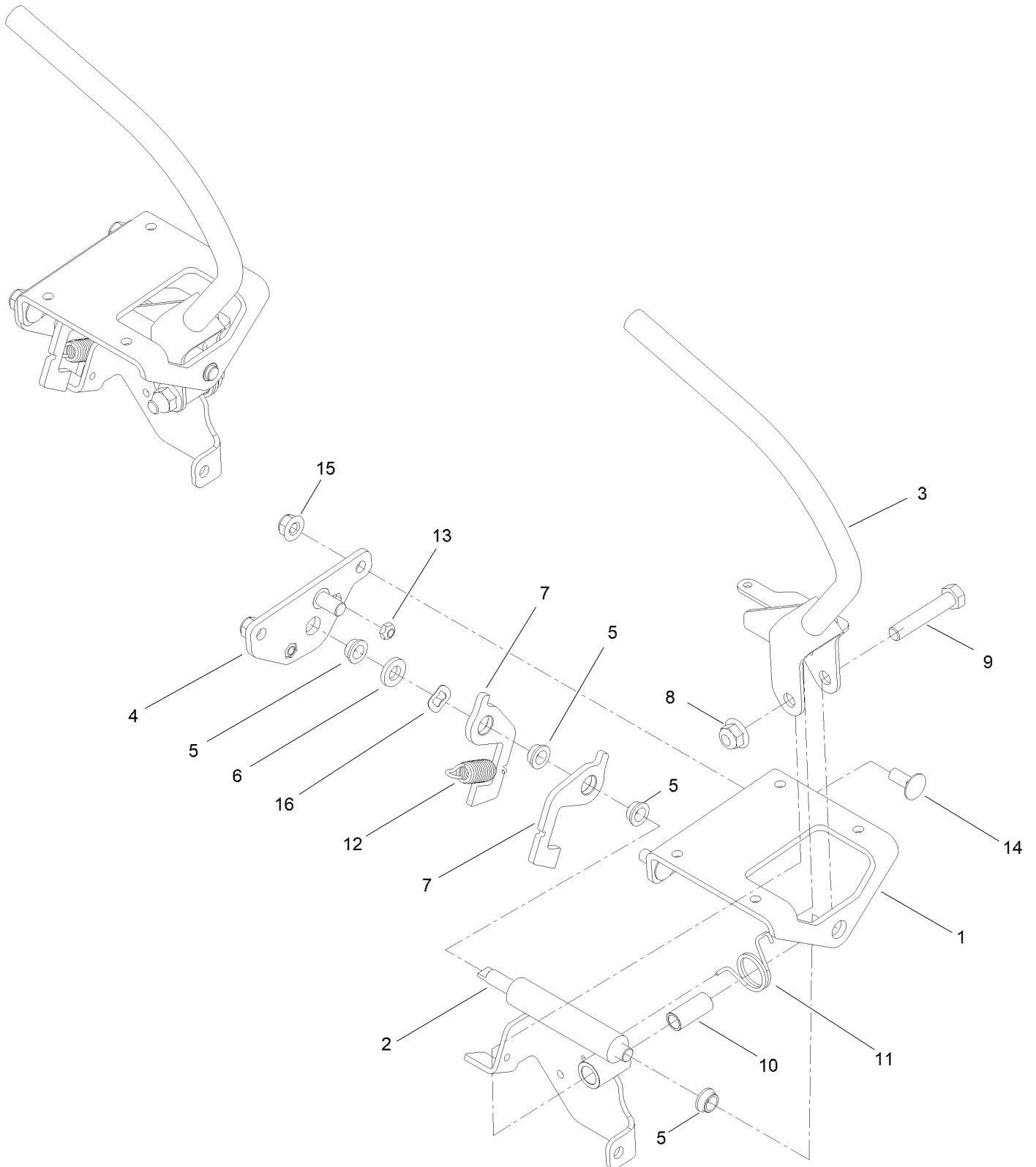

LH Control Handle Assembly No. 144-1421 (continued)

<i>Ref.</i>	<i>Part Number</i>	<i>Qty.</i>	<i>Description</i>	<i>Ref.</i>	<i>Part Number</i>	<i>Qty.</i>	<i>Description</i>
1	144-1427	1	Bracket-Control Mount	9	323-10	1	Screw-HH
2	145-3585	1	Motion Control ASM LH	10	131-3562	1	Bearing-Sleeve
3	145-3579	1	LH Lever ASM	11	139-1508	1	Spring-Torsion
4	144-1491	1	Plate ASM-Sensor LH	12	139-2859	1	Spring-Extension
5	139-1525	4	Bushing-Flanged Nylon	13	3296-12	2	Nut-Lock, NI
6	139-6293	1	Washer	14	3230-23	2	Bolt-CARR
7	139-1513	2	Plate-Spring	15	104-8300	2	Nut-HF, NI
8	104-8301	1	Nut-HF, NI	16	108472	1	Washer-Wave

RH Control Handle Assembly No. 144-1422

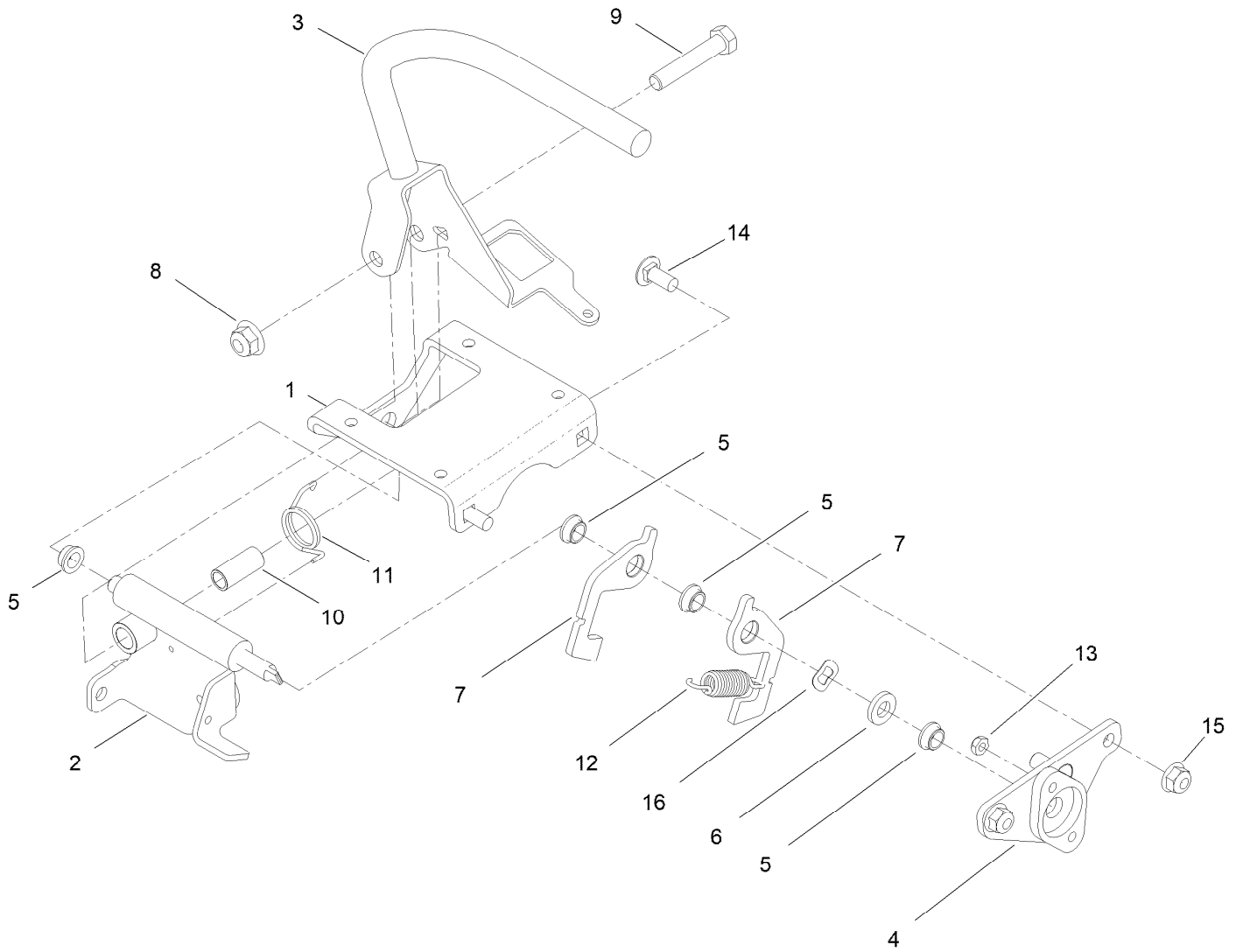

RH Control Handle Assembly No. 144-1422 (continued)

<i>Ref.</i>	<i>Part Number</i>	<i>Qty.</i>	<i>Description</i>	<i>Ref.</i>	<i>Part Number</i>	<i>Qty.</i>	<i>Description</i>
1	144-1427	1	Bracket-Control Mount	9	323-10	1	Screw-HH
2	145-3586	1	Motion Control ASM RH	10	131-3562	1	Bearing-Sleeve
3	145-3580	1	RH Lever ASM	11	139-1538	1	Spring-Torsion
4	144-1510	1	Plate ASM-Sensor RH	12	139-2859	1	Spring-Extension
5	139-1525	4	Bushing-Flanged Nylon	13	3296-12	2	Nut-Lock, NI
6	139-6293	1	Washer	14	3230-23	2	Bolt-CARR
7	139-1513	2	Plate-Spring	15	104-8300	2	Nut-HF, NI
8	104-8301	1	Nut-HF, NI	16	108472	1	Washer-Wave

Cover Assembly

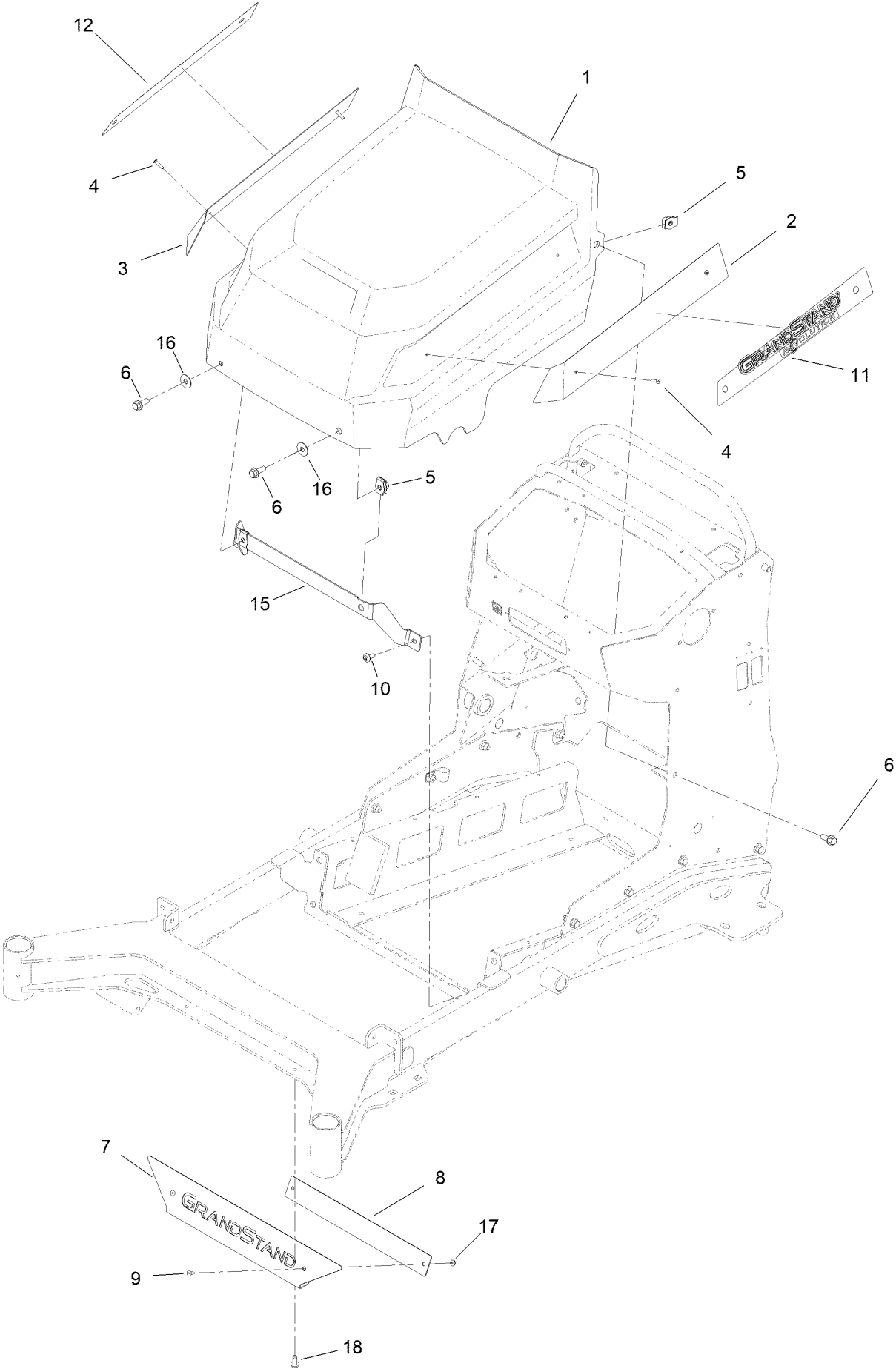

Cover Assembly (continued)

<i>Ref.</i>	<i>Part Number</i>	<i>Qty.</i>	<i>Description</i>	<i>Ref.</i>	<i>Part Number</i>	<i>Qty.</i>	<i>Description</i>
1	144-6896	1	Cover-Battery	9	114439	2	Rivet-Blind
2	144-6899	1	Plate-Insert, Cover	10	138-9753	2	Screw
3	144-6901	1	Plate-Insert, Cover	11	144-7007	1	Decal-Lithium Left
4	130-8451	4	Rivet-Trifold	12	144-7014	1	Decal-Lithium Right
5	105-4886	4	Nut-Tinnerman	15	144-6894-03	1	Bracket-Mount, Cover
6	3234-42	4	Screw-HHF	16	52-2860	2	Washer
7	144-7024-03	1	Plate-Front, Egrandstand	17	3269-26	2	Washer-Plain
8	144-7028	1	Plate-Cover	18	92-1624	2	Screw-HWH Thd Form

Deck Lift Assembly

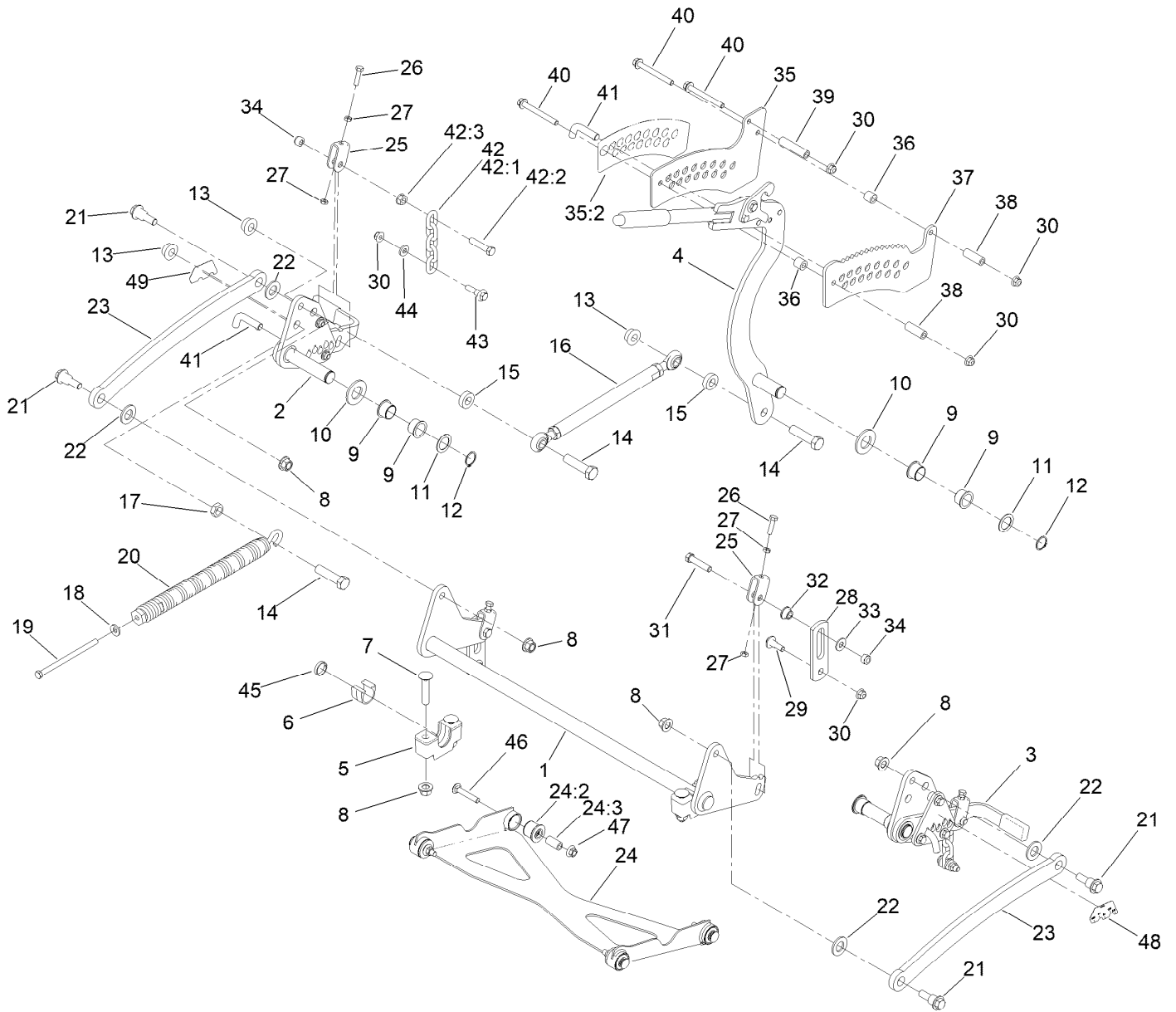

Deck Lift Assembly (continued)

<i>Ref.</i>	<i>Part Number</i>	<i>Qty.</i>	<i>Description</i>	<i>Ref.</i>	<i>Part Number</i>	<i>Qty.</i>	<i>Description</i>
1	120-8405-01	1	Shaft-Cross, Front	26	322-47	4	Screw-HH
2		1	Pivot ASM, HOC ●	27	3218-2	8	Nut-Hex Jam
3		1	Pivot ASM, HOC ●	28	130-6589	2	Link-Lift
4	130-1755	1	HOC Lever ASM	29	109-9840	2	Screw-Shoulder, HHF
5	109-9409	2	Support-Bearing, Cross Shaft (Front)	30	104-8301	7	Nut-HF, NI
6	109-9410	2	Bearing-Cross Shaft, Front	31	109-9065	2	Screw-HH
7	116-1700	4	Bolt-CARR	32	116-2428	2	Bushing-Flanged
8	99-5107	8	Nut-Lock	33	3256-4	4	Washer-Flat
9	127-0369	6	Bushing	34	3296-48	4	Nut-Hex
10	3256-62	3	Washer-Flat	35	147-1676	1	HOC Plate And Decal ASM
11	10-8110	3	Washer-Thrust	35:2	140-5405	1	Decal-HOC
12	32151-29	3	Ring-Retaining	36	121-1760	2	Spacer
13	138-4932	3	Nut-Hex Flg	37	138-4887	1	Plate-HOC, Inner
14	138-4931	3	Screw-Lock	38	95-6448	2	Spacer
15	119-6223	2	Washer	39	138-1111	1	Spacer
16	130-6615	1	HOC Link ASM	40	116-4701	3	Screw-HHF
17	3218-6	1	Nut-Jam	41	138-7203	3	Pin-HOC
18	98-5975	1	Washer-Belleville	42	116-0756	2	Deck Lift Chain ASM
19	323-58	1	Bolt-TAP, HH	42:1	1-633447	1	Chain-Lift, Deck
20	116-0886	1	Spring-Extension	42:2	109-9065	1	Screw-HH
21	116-0780	4	Screw-Shoulder, HHF	42:3	32128-37	1	Nut-HF
22	3256-28	4	Washer-Flat	43	130-0742	2	Bolt-Shoulder
23	127-1948-03	2	Link-Lift	44	43-0940	2	Spacer
24	137-4129	1	Deck Strut ASM	45	133-1431	1	Spacer-Split
24:2	137-4108	4	Bushing-Rubber	46	3231-7	4	Screw-CARR
24:3	108-6544	4	Spacer	47	32128-19	4	Nut-HF Lock, Large Flg
25	109-9066	4	Yoke-Adjust, Deck	48	144-7013	1	Decal-Deck Rake, LH
				49	144-7012	1	Decal-Deck Rake, RH

● Not serviced separately

HOC Pivot Assembly No. 144-1554

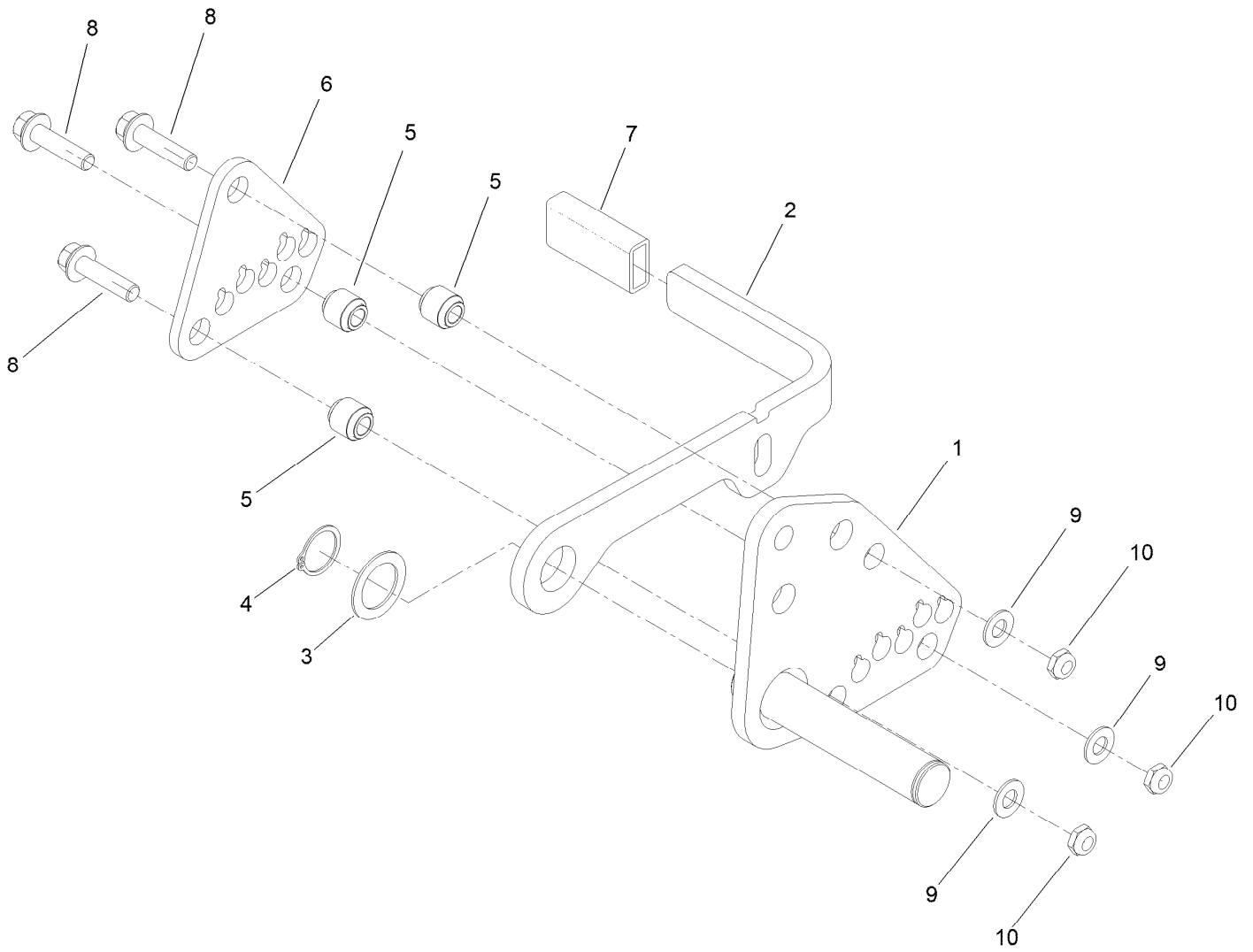

HOC Pivot Assembly No. 144-1554 (continued)

<i>Ref.</i>	<i>Part Number</i>	<i>Qty.</i>	<i>Description</i>	<i>Ref.</i>	<i>Part Number</i>	<i>Qty.</i>	<i>Description</i>
1	144-1550-01	1	Pivot ASM-RH HOC [red]	6	144-1553-01	1	Plate-Rake Adj, Outer
2	144-1547-01	1	Lever-Rake, Deck [red]	7	116-4312	1	Grip-Flat
3	10-8110	1	Washer-Thrust	8	114-4681	3	Screw-HHF
4	32151-29	1	Ring-Retaining	9	48-9220	3	Washer-Flat
5	138-7201	3	Spacer-Double Step	10	3296-59	3	Nut-Lock, NI

HOC Pivot Assembly No. 144-1555

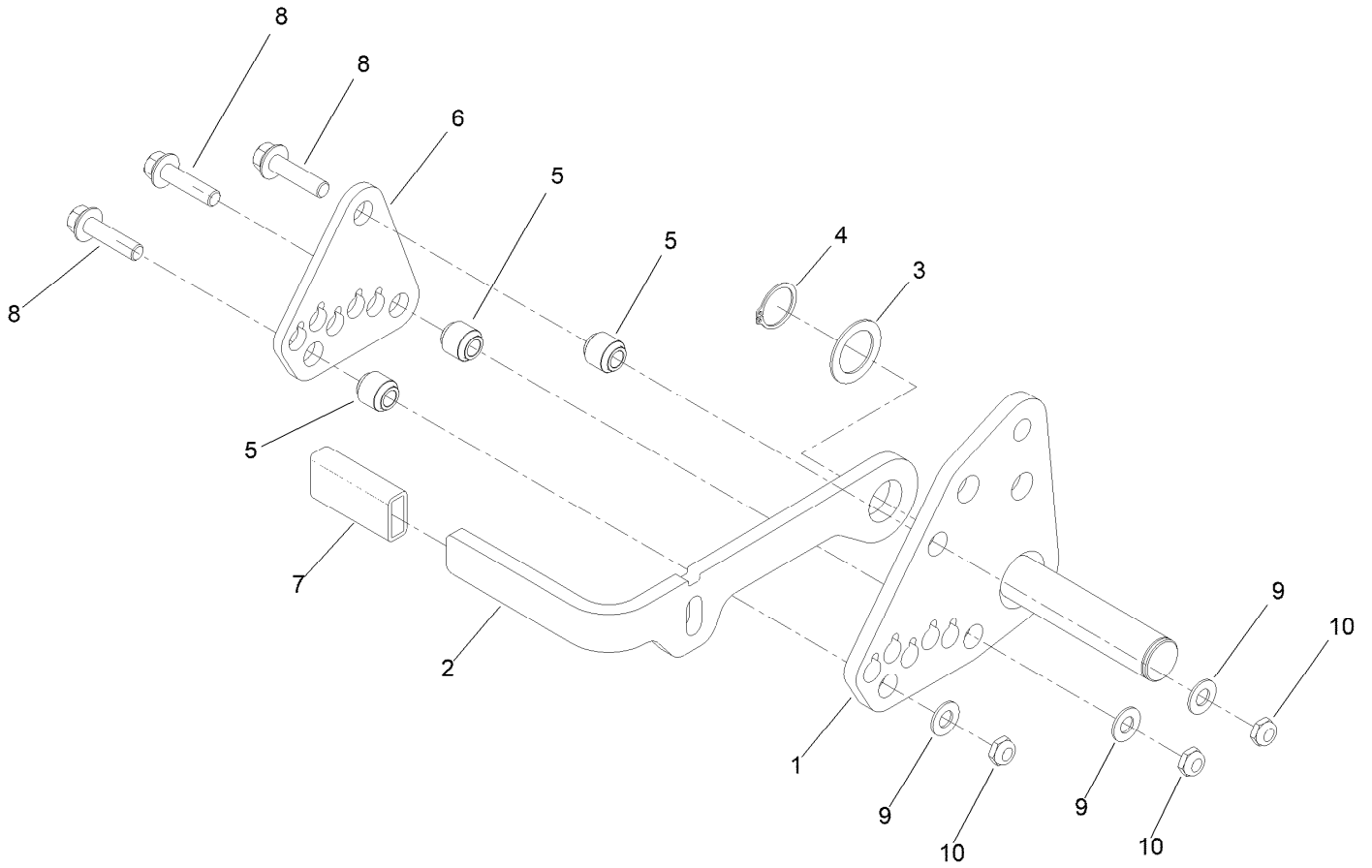

HOC Pivot Assembly No. 144-1555 (continued)

<i>Ref.</i>	<i>Part Number</i>	<i>Qty.</i>	<i>Description</i>	<i>Ref.</i>	<i>Part Number</i>	<i>Qty.</i>	<i>Description</i>
1	144-1556-01	1	Pivot ASM-LH HOC [red]	6	144-1553-01	1	Plate-Rake Adj, Outer
2	144-1558-01	1	Lever-Rake, Deck [red]	7	116-4312	1	Grip-Flat
3	10-8110	1	Washer-Thrust	8	114-4681	3	Screw-HHF
4	32151-29	1	Ring-Retaining	9	48-9220	3	Washer-Flat
5	138-7201	3	Spacer-Double Step	10	3296-59	3	Nut-Lock, NI

HOC Level Assembly No. 130-1755

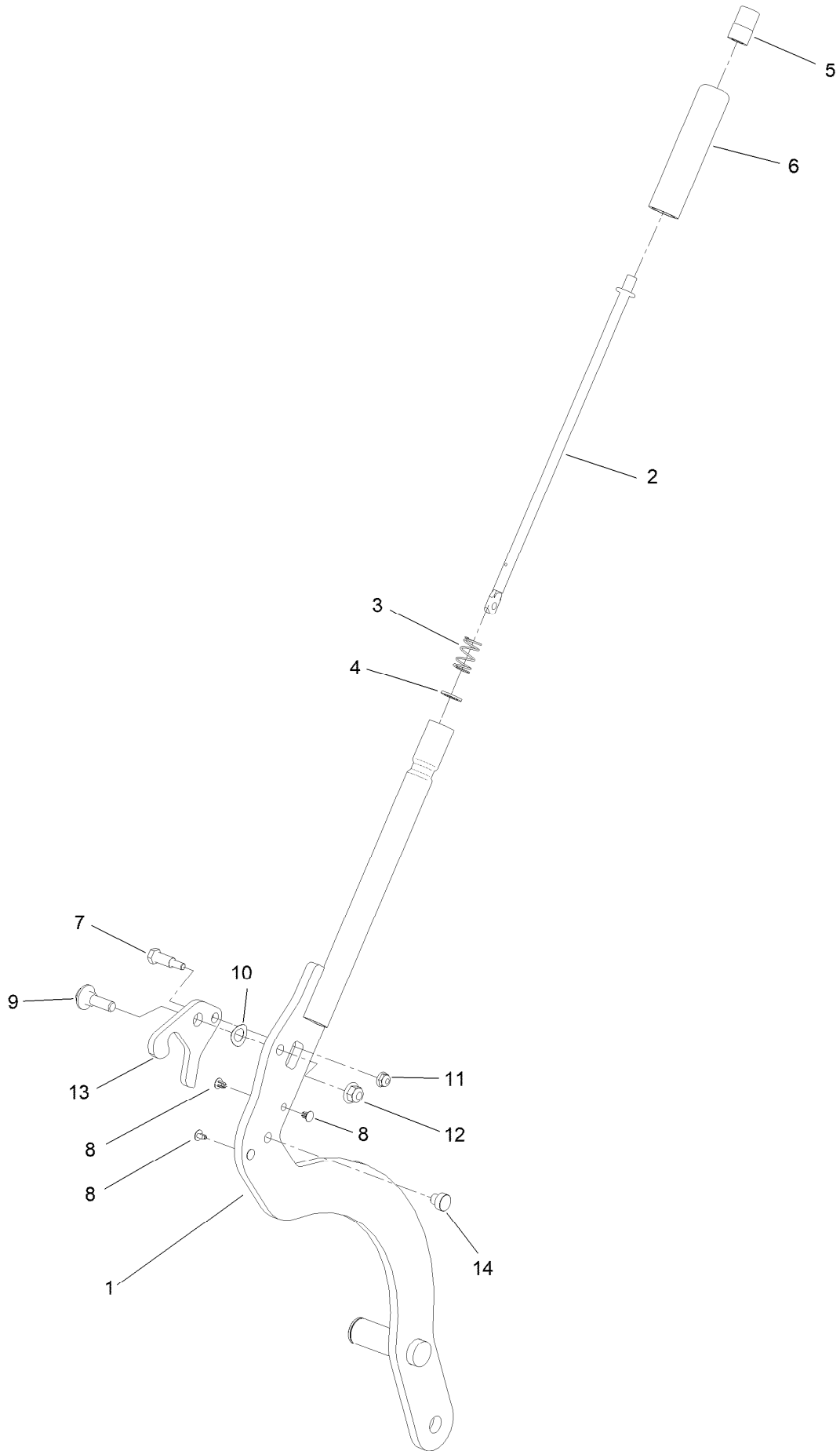

HOC Level Assembly No. 130-1755 (continued)

<i>Ref.</i>	<i>Part Number</i>	<i>Qty.</i>	<i>Description</i>	<i>Ref.</i>	<i>Part Number</i>	<i>Qty.</i>	<i>Description</i>
1	130-1775-01	1	Lever-Lift	8	103-1363	4	Rivet
2	136-0530	1	Rod-Latch, Release	9	614672	1	Screw-Shoulder, HWH
3	114-8187	1	Spring-Compression	10	110-8982	1	Washer-Spring
4	114-1207	1	Washer-Special	11	104-7201	1	Nut-HF, NI
5	115-2750	1	Knob	12	104-8301	1	Nut-HF, NI
6	115-3592	1	Grip	13	138-4888	1	Latch-HOC
7	119-2309	1	Bolt-Shoulder	14	138-4863	1	Plug-Wear

HOC Link Assembly No. 130-6615

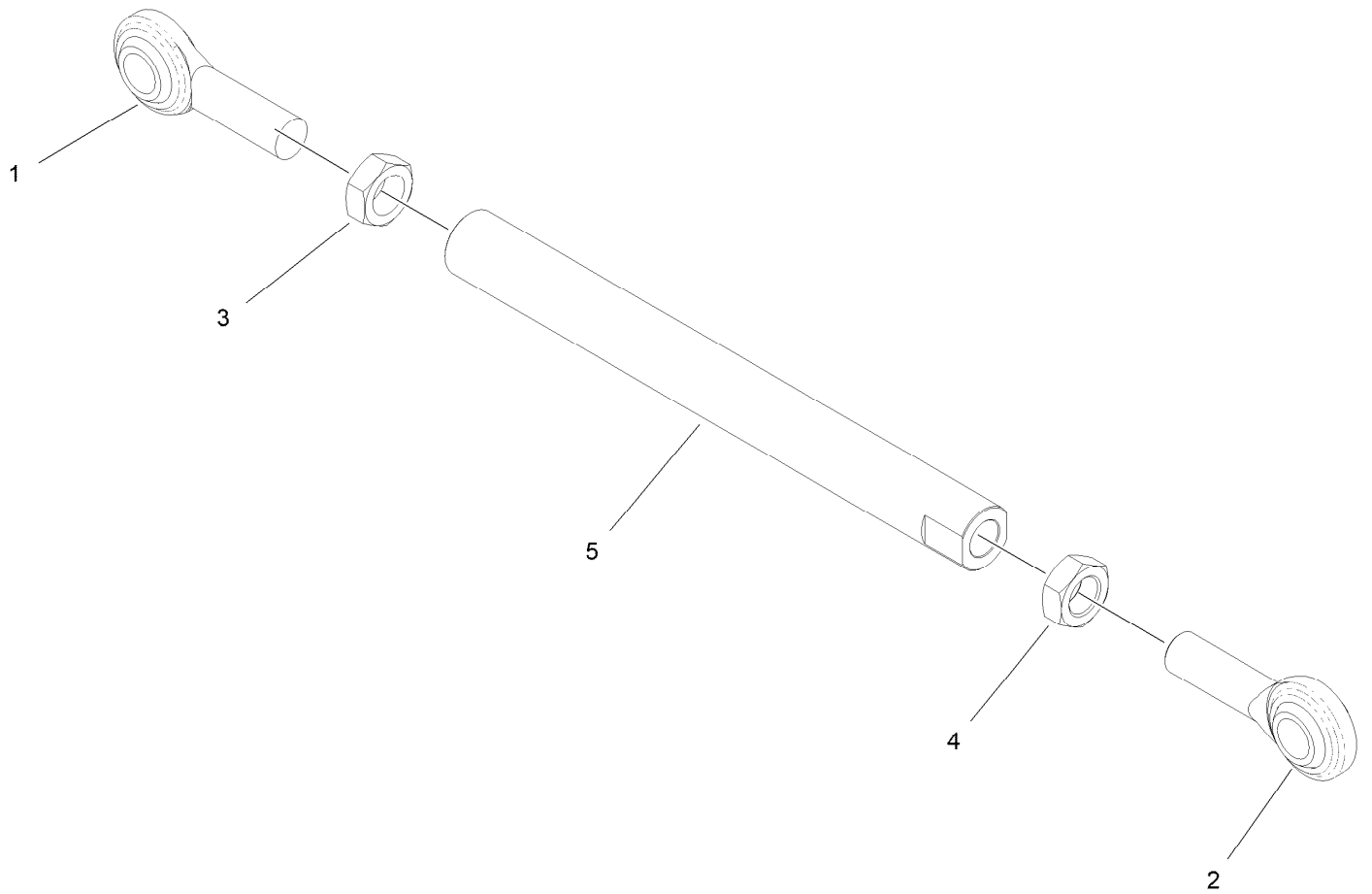

HOC Link Assembly No. 130-6615 (continued)

<i>Ref.</i>	<i>Part Number</i>	<i>Qty.</i>	<i>Description</i>
1	1-633029	1	Balljoint-Spherical
2	117-5291	1	Balljoint-Spherical
3	3220-6	1	Nut-Jam

<i>Ref.</i>	<i>Part Number</i>	<i>Qty.</i>	<i>Description</i>
4	117-5293	1	Nut-Jam
5	130-6614	1	Link-Height Of Cut

Frame Assembly

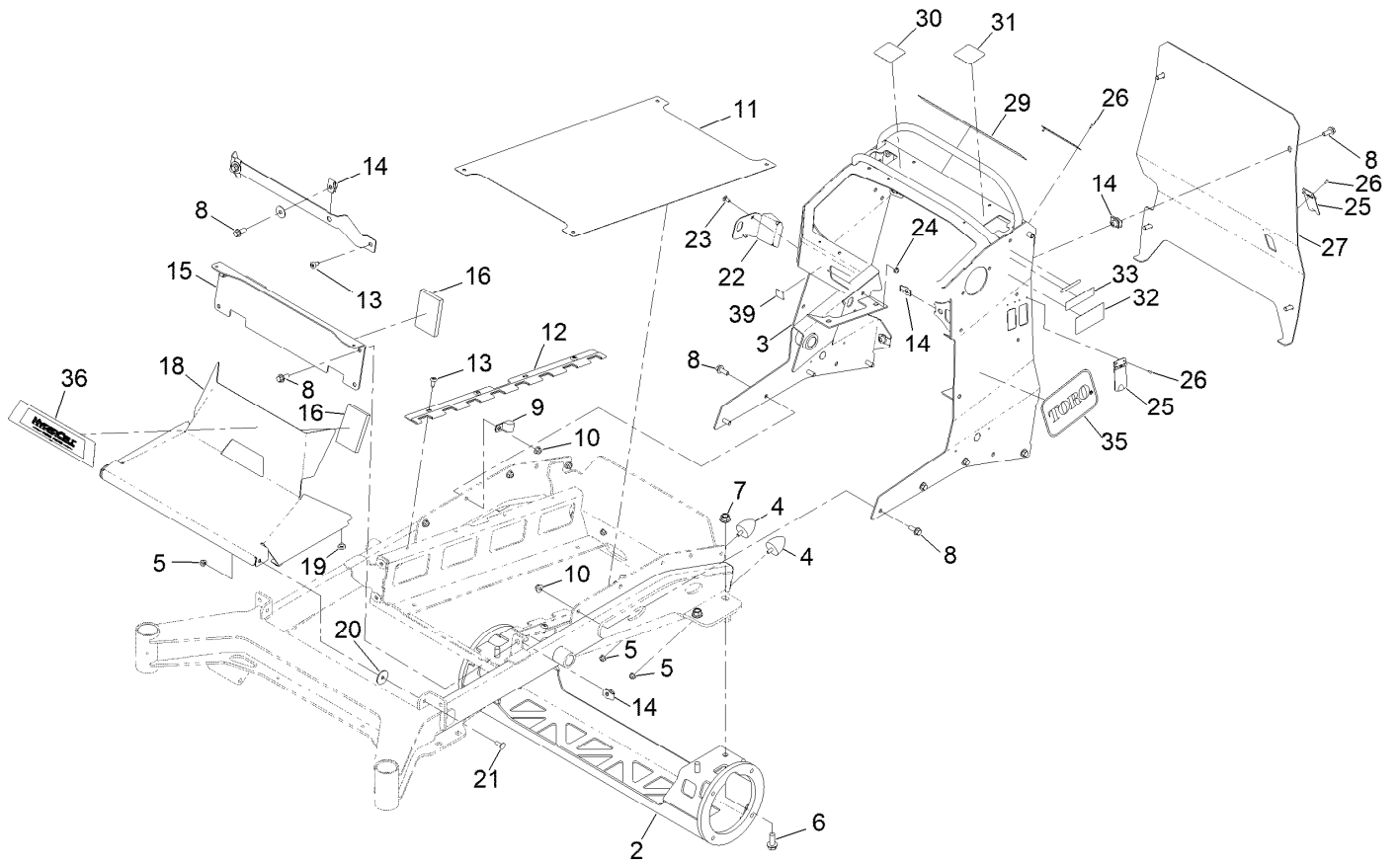

Frame Assembly (continued)

<i>Ref.</i>	<i>Part Number</i>	<i>Qty.</i>	<i>Description</i>	<i>Ref.</i>	<i>Part Number</i>	<i>Qty.</i>	<i>Description</i>
2	144-3840-01	1	Frame-Axle ASM [red]	20	107-3002	2	Washer-Nylon
3	144-1580	1	Tower ASM	21	3230-10	2	Bolt-CARR
4	114-1926	4	Bumper-Rubber	22	144-6862	1	Plate-Latch
5	104-8300	6	Nut-HF, NI	23	3229-11	1	Screw-CARR
6	3234-38	4	Screw-HHF	24	104-7201	1	Nut-HF, NI
7	99-5107	4	Nut-Lock	25	144-6628	2	Plate-Cover, Spring
8	3234-42	14	Screw-HHF	26	3290-271	6	Rivet-Pop
9	2412-4	2	Clamp-R	27	144-3876-03	1	Plate-Cover, Plate
10	104-8301	8	Nut-HF, NI	29	147-7854	1	Decal-Warning
11	145-3403-03	1	Plate-Skid	30	144-7004	1	Decal-OPC Control, Right
12	144-3874-03	2	Bracket-Retention, Battery	31	144-7003	1	Decal-OPC Control, Left
13	138-9753	6	Screw	32	147-0289	1	Decal-Charging Port
14	105-4886	10	Nut-Tinnerman	33	144-7008	1	Decal-Service, Shut-Off
15	144-6957-03	1	Plate-Battery Mnt	35	145-3437	2	Decal-Toro Logo
16	100-2196	3	Pad-Foam	36	144-7015	1	Decal-Hypercell 1900
18	144-7023-03	1	Cover-Motor Controller	39	147-0290	1	Decal-Light, Warning
19	1-513658	4	Bumper				

Platform Assembly

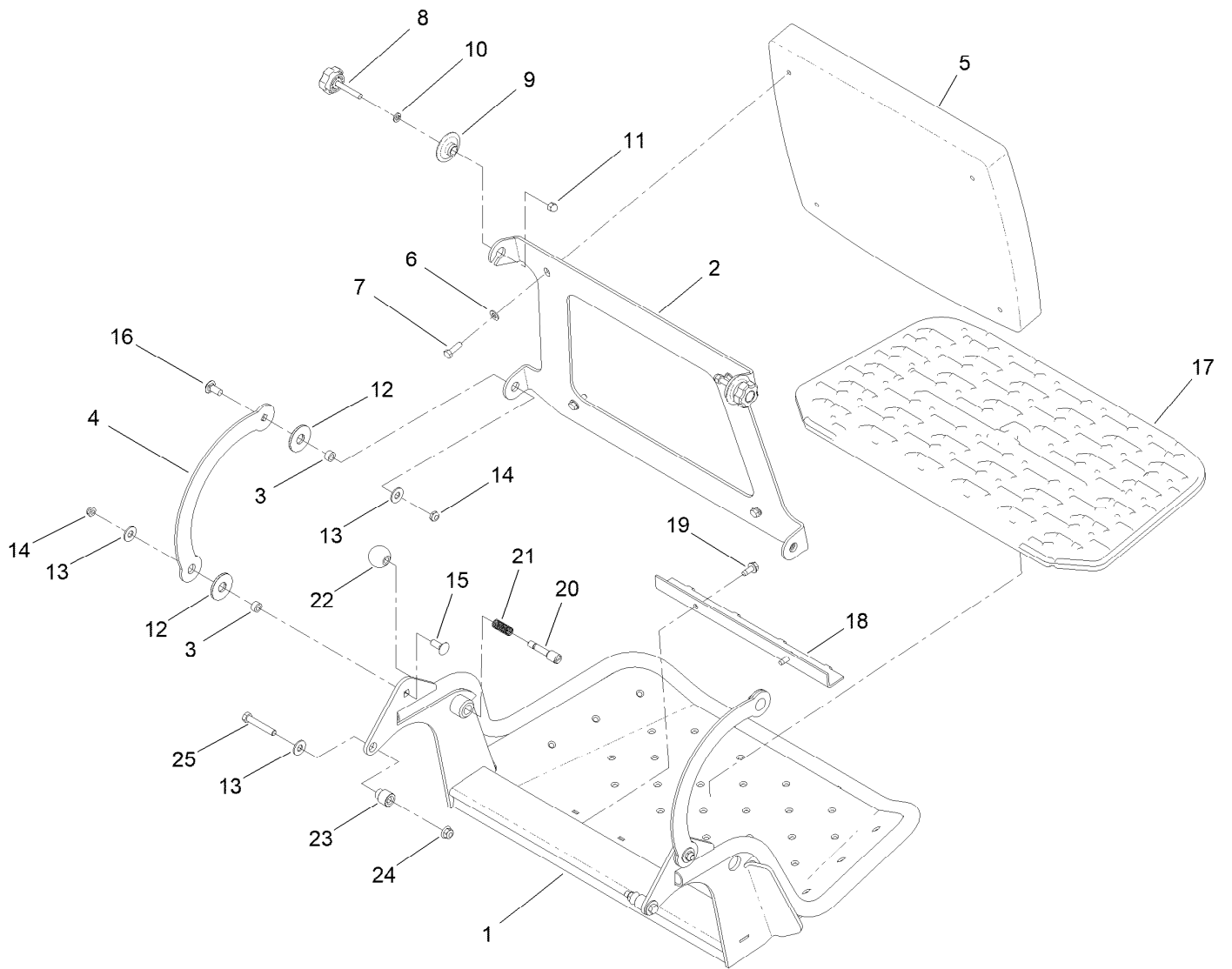

Platform Assembly (continued)

<i>Ref.</i>	<i>Part Number</i>	<i>Qty.</i>	<i>Description</i>	<i>Ref.</i>	<i>Part Number</i>	<i>Qty.</i>	<i>Description</i>
1	120-8475-01	1	Platform	14	3296-59	4	Nut-Lock, NI
2	120-8499-03	1	Hinge-Pad	15	3231-2	2	Bolt-CARR
3	111044	4	Spacer	16	3231-27	2	Screw-CARR
4	114-1915-01	2	Link-Pad	17	144-6958	1	Mat, Platform
5	145-3535	1	Cushion Pad ASM	18	114-1920-03	1	Clamp-Shield
6	3256-23	4	Washer-Plain	19	32144-70	2	Screw-HWHTF
7	121-7999	4	Screw-HH	20	119-8650	1	Pin-Latch
8	133-1426	2	Knob	21	114-5348	1	Spring
9	116-2886	2	Slide-Bushing	22	1-603175	1	Knob-Ball
10	3253-4	2	Washer-Lock	23	132-7583	2	Bushing-Flanged
11	137-4808	2	Nut-Acorn	24	104-8301	2	Nut-HF, NI
12	114-0463	4	Washer-Friction, Composite	25	323-45	2	Screw-HH
13	3256-4	6	Washer-Flat				

Front Caster Assembly

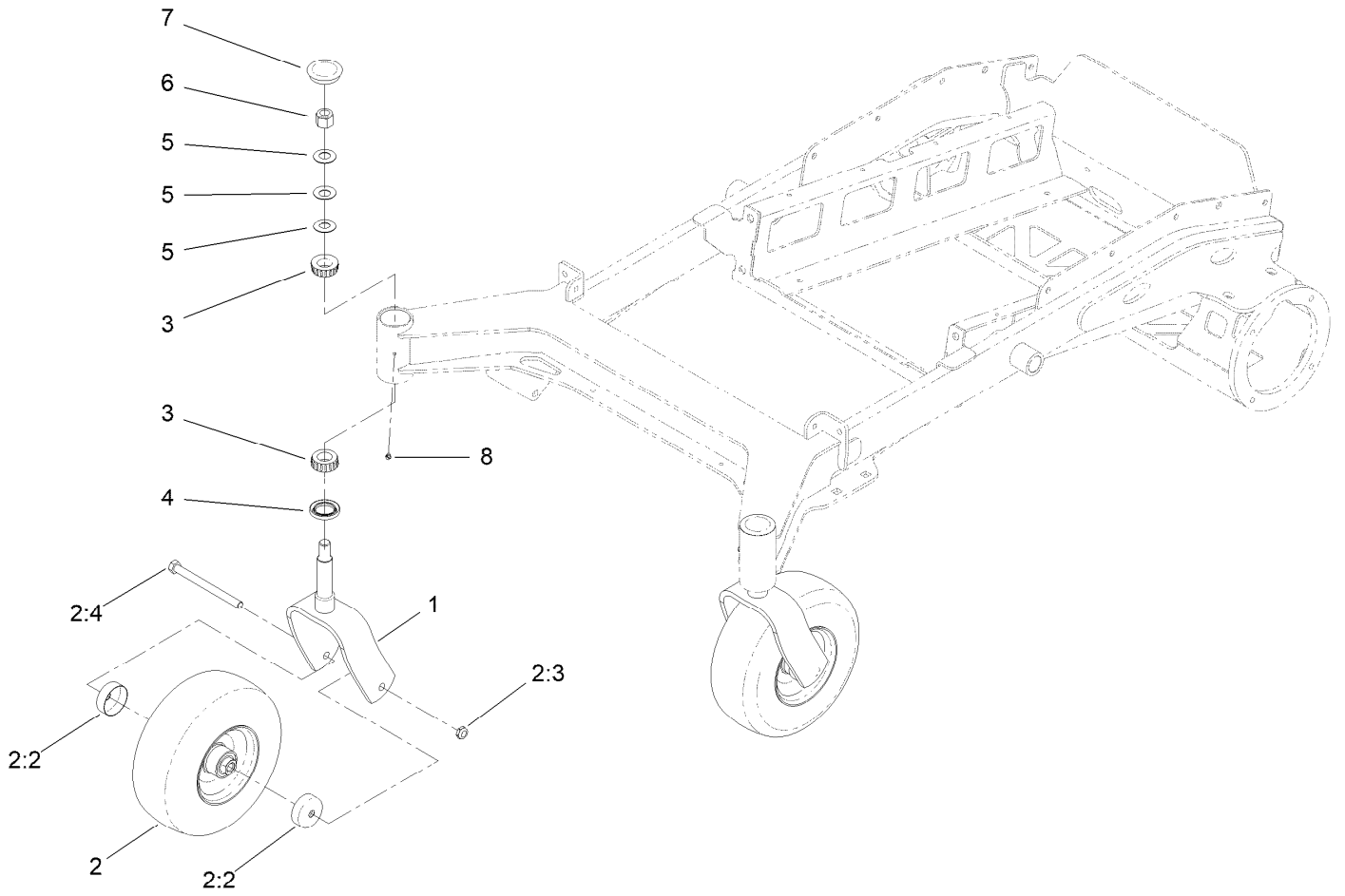

Front Caster Assembly (continued)

<i>Ref.</i>	<i>Part Number</i>	<i>Qty.</i>	<i>Description</i>	<i>Ref.</i>	<i>Part Number</i>	<i>Qty.</i>	<i>Description</i>
1	121-7988-01	2	Fork-Caster	4	116-5647	2	Seal-Grease
2	140-5485	2	Mf Wheel Tire Bearing ASM	5	1-633508	6	Washer-Bellville
2:2	103-2768	2	Guard-Seal	6	3296-51	2	Nut-Lock, NI
2:3	3296-45	1	Nut-Hex	7	145-3415	2	Cap, Grease
2:4	325-20	1	Screw-HH	8	1-811010	2	Plug
3	1-543509	4	Bearing-Roller, Tapered				

Wheel and Bearing Assembly



Wheel and Bearing Assembly (continued)

<i>Ref.</i>	<i>Part Number</i>	<i>Qty.</i>	<i>Description</i>	<i>Ref.</i>	<i>Part Number</i>	<i>Qty.</i>	<i>Description</i>
1	1-633585	2	Bearing-Cone, Taper	4	126-5359	1	Caster Axle ASM
2	103-0063	2	Seal-Caster	5	140-5483	1	Mf Wheel And Tire ASM
3	103-3051	1	Spacer-Nut				

Battery Assembly

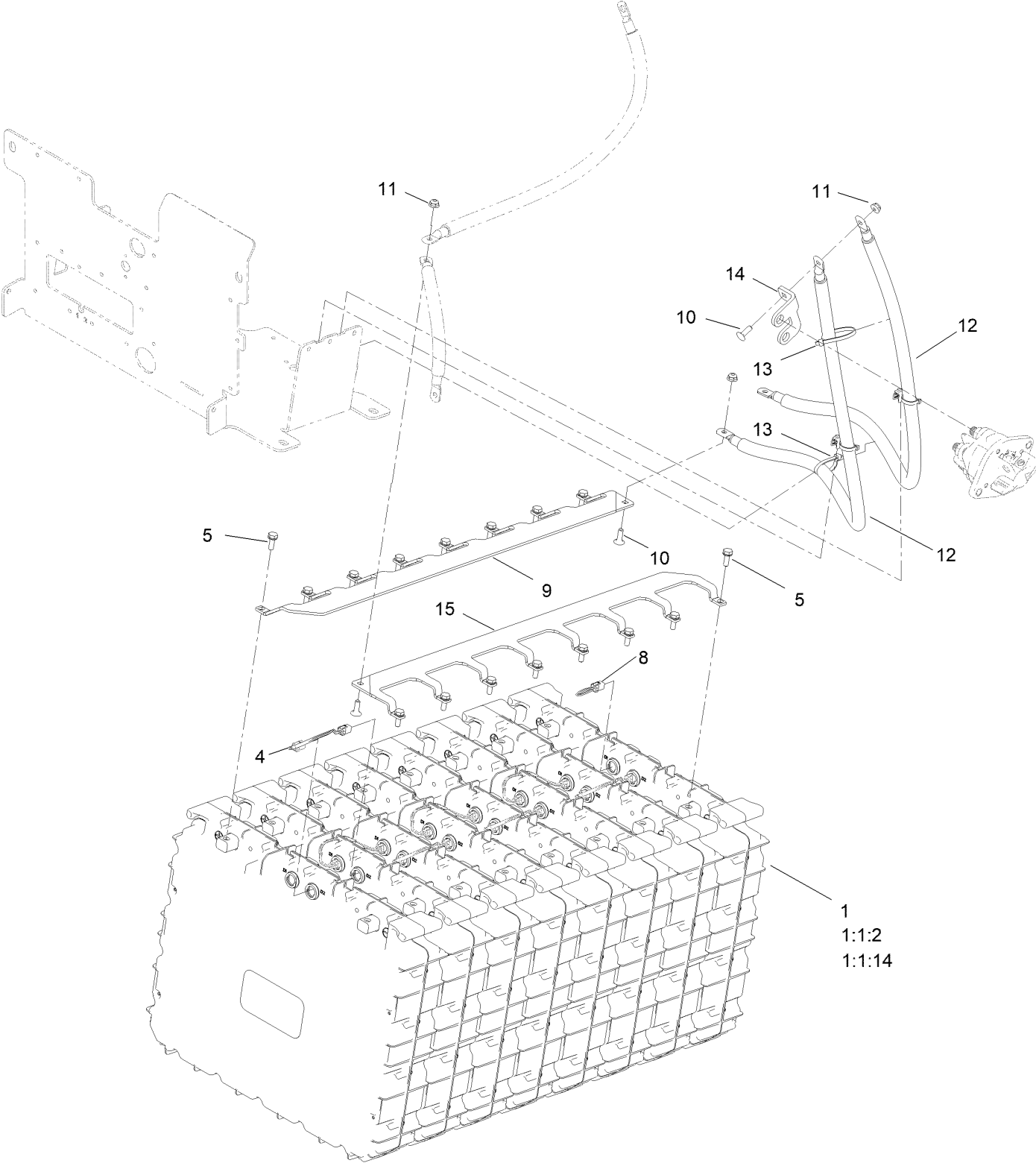

Battery Assembly (continued)

<i>Ref.</i>	<i>Part Number</i>	<i>Qty.</i>	<i>Description</i>	<i>Ref.</i>	<i>Part Number</i>	<i>Qty.</i>	<i>Description</i>
1	145-5320	8	Battery ASM	12	147-0273	2	Cable-Battery,Rd ASM
1:1:2	145-5338	1	Decal-Warning, Battery	13	3290-378	2	Tie-Cable
1:1:14	32180-466	2	Nut-Mounting, Jwpcf Panel Lock	14	147-0370	1	Busbar-2, Switch
4	140-9565	7	Harness-Wire, Data Interface	15	147-0341	1	Busbar-8, Bk
5	145-5783	16	Screw-Sems	99	147-7790	1	Charger-Rc1200, 1200W ●
8	122-2323	1	Harness-Wire, Can Terminator	99	147-7791	1	Adapter, AC, 250V/10A, EU To Uk ●
9	147-0234	1	Busbar-8, Rd	99	147-7792	1	Adapter, AC, 250V/10A, EU To Australia ●
10	1-807512	3	Bolt-CARR	99:1	147-6297	1	Cord-AC, 120V ●
11	104-7201	3	Nut-HF, NI	99:2	147-0227	1	Cable, DC-Hypercell ●

● Not illustrated

Electrical Assembly

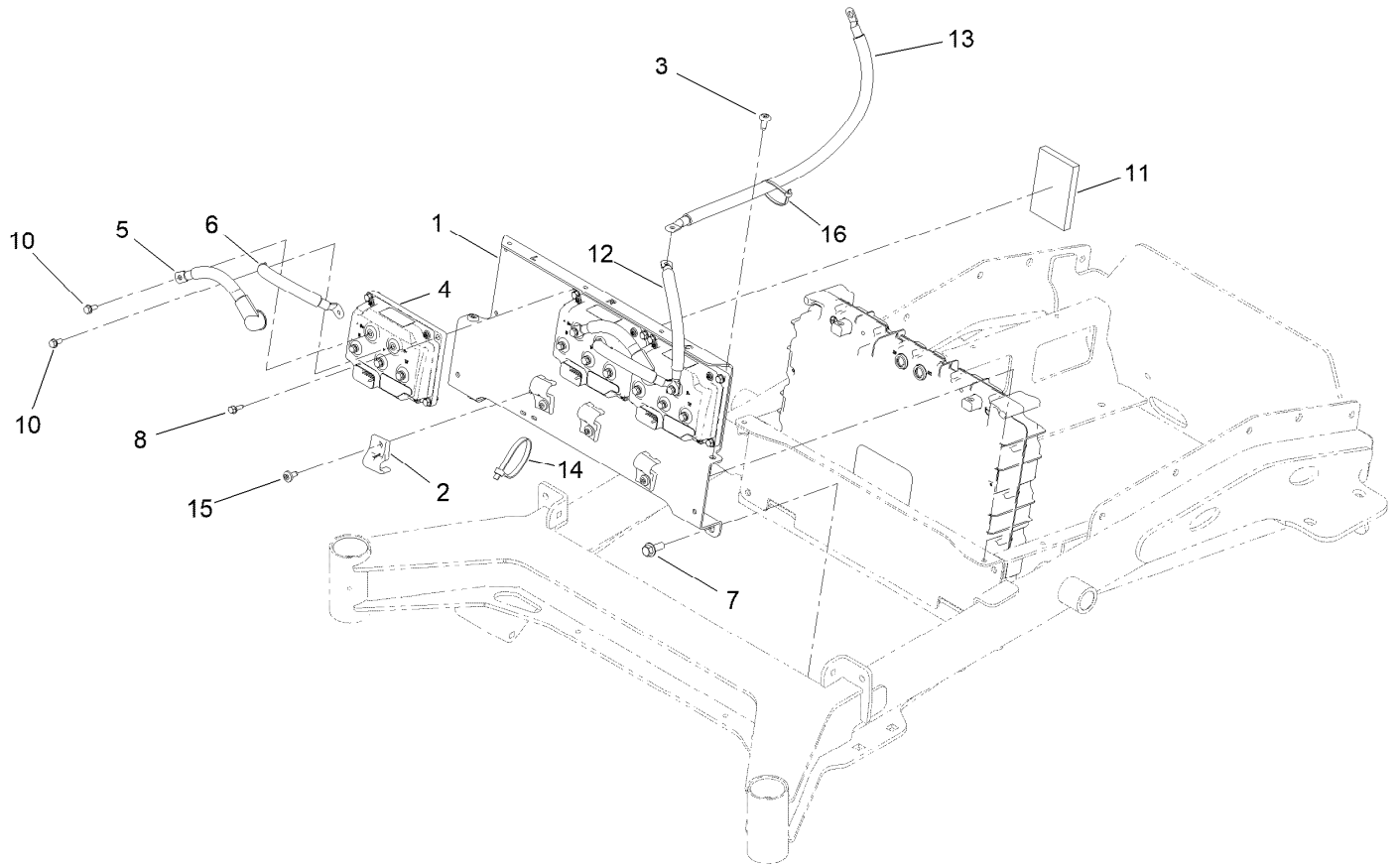

Electrical Assembly (continued)

<i>Ref.</i>	<i>Part Number</i>	<i>Qty.</i>	<i>Description</i>	<i>Ref.</i>	<i>Part Number</i>	<i>Qty.</i>	<i>Description</i>
1	144-6956-03	1	Plate-Motor Controller Mnt	10	145-5782	15	Screw-Sems
2	145-6985	4	Mount-Cable	11	100-2196	1	Pad-Foam
3	138-9753	2	Screw	12	147-0241	1	Cable-Battery, Bk ASM
4	145-7270	3	Inv/Ctrlr-48V	13	147-0242	1	Cable-Battery, Bk ASM
5	147-0238	2	Cable-Battery, Rd ASM	14	3334-945	1	Tie-Cable
6	147-0239	2	Cable-Battery, Bk ASM	15	120-7950	4	Screw-Torx
7	3234-42	2	Screw-HHF	16	3290-379	1	Tie-Cable
8	32144-44	12	Screw-HWH, Thread Roll				

Battery Cable Assembly

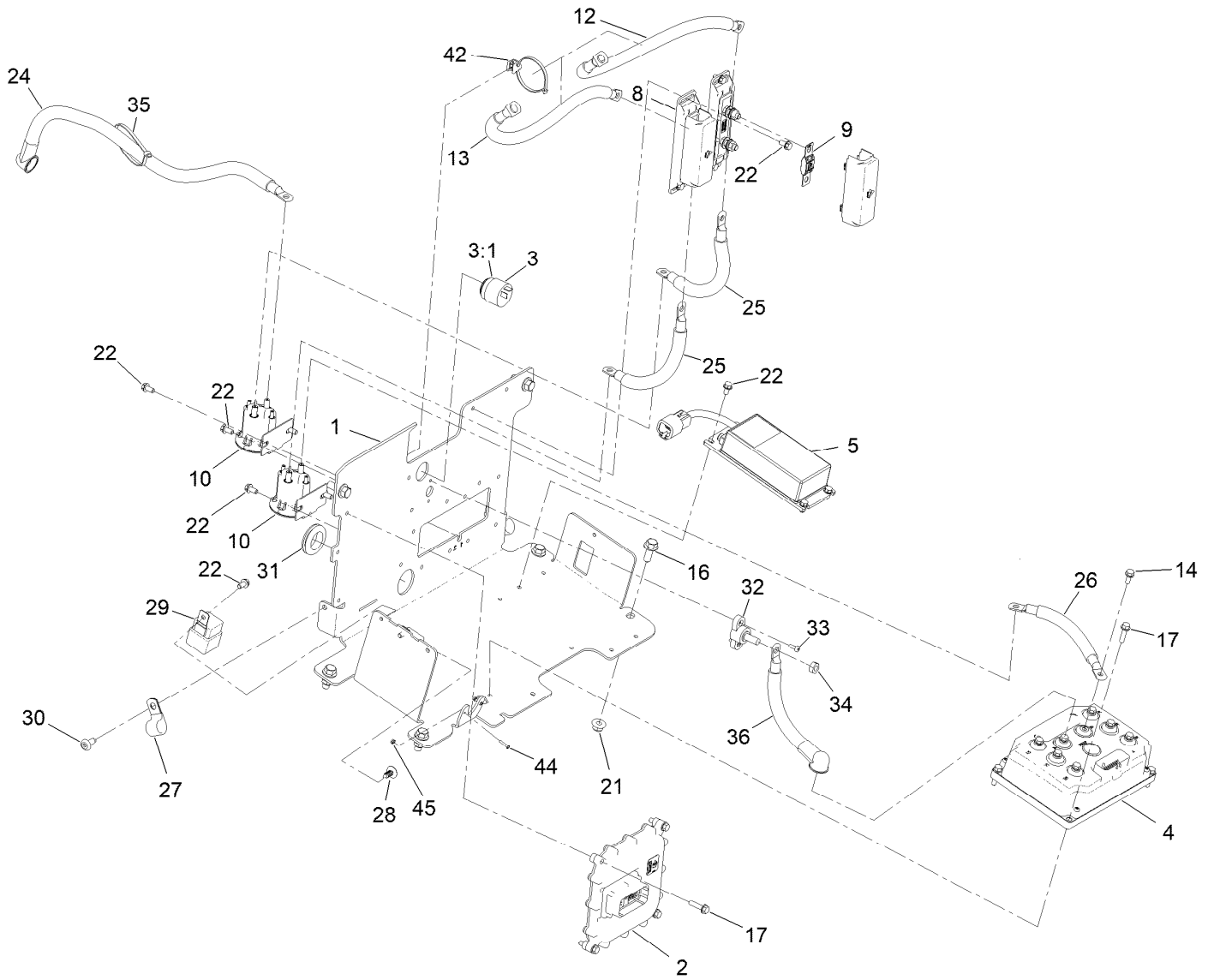

Battery Cable Assembly (continued)

<i>Ref.</i>	<i>Part Number</i>	<i>Qty.</i>	<i>Description</i>	<i>Ref.</i>	<i>Part Number</i>	<i>Qty.</i>	<i>Description</i>
1	145-3563-03	1	Plate-Mnt, Electrical	25	147-0225	2	Cable-Battery, Rd ASM
2	127-2770	1	Controller	26	147-0237	1	Cable-Battery, Rd ASM
3	80-9330	1	Audio Alarm ASM	27	2412-4	2	Clamp-R
3:1	104-5107	1	Nut-Plastic, Knurled	28	117-2382	1	Plug-Plastic
4	138-8984	1	Inv/Ctrlr-48V,Dual 94Arms	29	70-1480	2	Relay
5	144-6975	1	Converter DC-DC	30	138-9753	2	Screw
8	145-4958	2	Holder-Fuse	31	120-3265	1	Grommet
9	122-2561	2	Fuse-200A	32	110-8823	1	Block-Junction
10	145-3542	2	Contacto-DC, 12V	33	105-6849	2	Screw-Forming, Thread
12	147-0332	1	Cable-Battery, Rd ASM	34	3217-7	1	Nut-Hex
13	147-0331	1	Cable-Battery, Rd ASM	35	3290-379	1	Tie-Cable
14	145-5782	8	Screw-Sems	36	147-0240	1	Cable-Battery, Bk ASM
16	3234-42	6	Screw-HHF	42	32180-150	1	Clip-Harness. Edge, W/Tie-Wrap
17	32144-86	8	Screw-HWHTF	44	1-3084	2	Screw-PPH
21	104-8301	4	Nut-HF, NI	45	9157324	2	Nut-Hex, NYL INS
22	32144-4	14	Screw-HWH				
24	147-0228	1	Cable-Battery, Rd ASM				

Control Panel and Harness Assembly

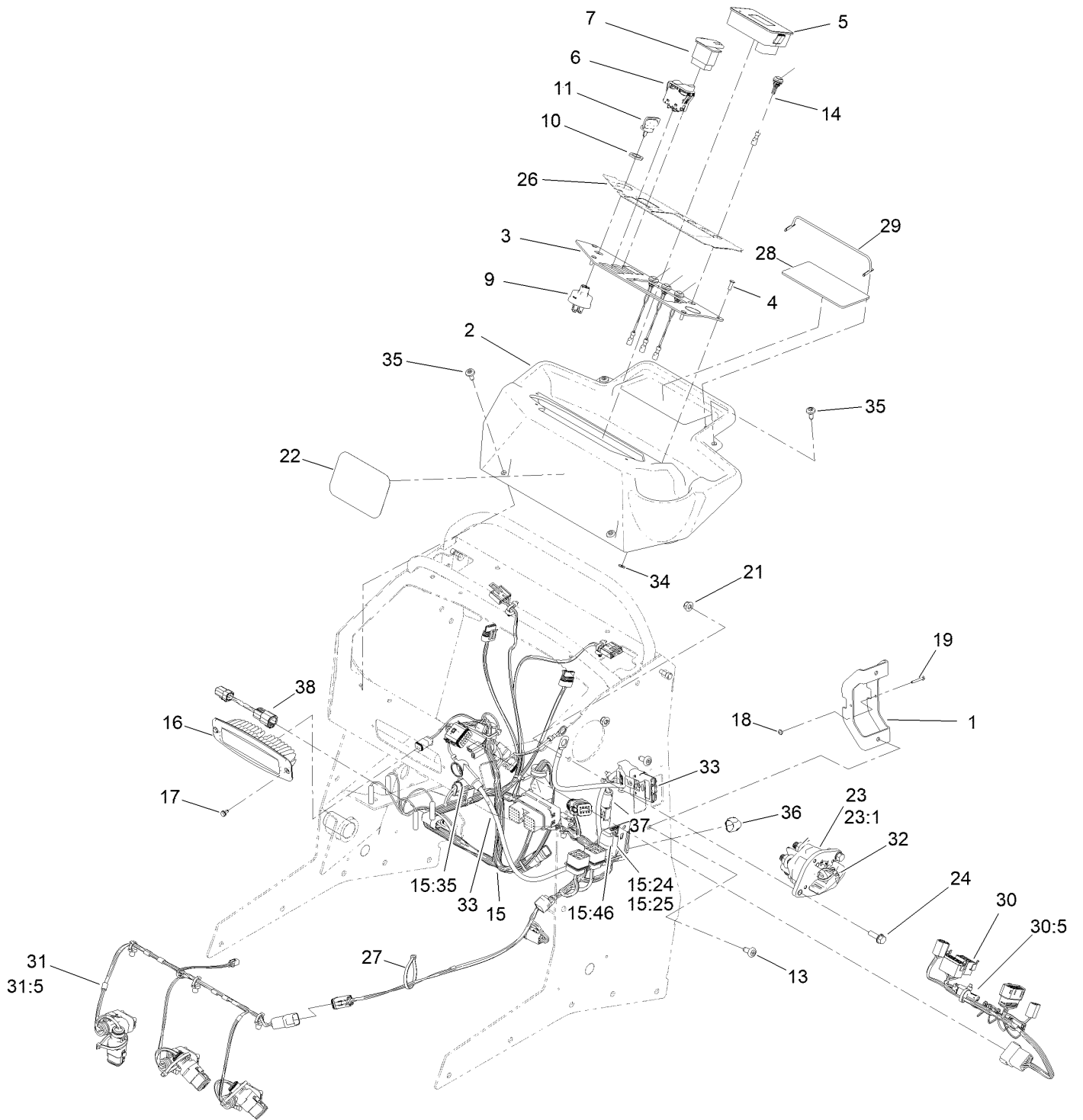

Control Panel and Harness Assembly (continued)

<i>Ref.</i>	<i>Part Number</i>	<i>Qty.</i>	<i>Description</i>	<i>Ref.</i>	<i>Part Number</i>	<i>Qty.</i>	<i>Description</i>
1	145-3597-03	1	Bracket-Charger, Dual	21	104-8300	2	Nut-HF, NI
2	144-1576	1	Dash-Control Panel	22	94-2579	1	Decal
3	147-1685-03	1	Plate-Control Panel	23	122-0603	1	Switch-Disconnect
4	3269-4	4	Rivet-Pop	23:1	33006-00	1	Nut-HF
5	122-1201	1	Module-Display	24	3234-29	2	Screw-HHF
6	139-6367	1	Switch-Rocker, (On)-On-Off	26	147-1686	1	Decal-Panel, Control
7	95-8999	1	Switch-Rocker, On-None-On	27	3290-379	1	Tie-Cable
9	139-7716	1	Switch-Key, Spst	28	145-3410	1	Pad-Rubber, W/Adhesive
10	101884	1	Nut	29	144-6973	1	Strap-Elastic
11	63-8360	1	Key-Ignition	30	145-3411	1	Harness-Wire, Control Panel
13	138-9753	2	Screw	30:5	32180-282	1	Resistor-120 Ohm
14	136-9678	4	Switch-Pushbutton	31	145-3412	1	Harness-Wire, Deck
15	140-9567	1	Harness-Wire, Main	31:5	32180-282	1	Resistor-120 Ohm
15:24	121-8861	2	Fuse-Mini Blade, 2 Amp	32	3290-378	5	Tie-Cable
15:25	121-8864	3	Fuse-Mini Blade, 5 Amp ●	33	140-9596	1	Harness-Wire, Charger Port
15:35	117-4724	1	Fuse-Blade, 10A	34	3269-26	4	Washer-Plain
15:46	121-8865	1	Fuse-Mini Blade, 7.5 Amp	35	120-7950	4	Screw-Torx
16	139-8089	1	Mount-Flush, Light	36	32180-089	1	Cap-Plug, 3 Way
17	104-2065	2	Screw-HWH	37	112-1540	1	Ferrite-Snap On
18	3296-9	1	Nut-Hex	38	161-3544	1	Harness-Wire, Jumper
19	32105-9	1	Screw-HH				

● Not illustrated

Attachments and Accessories

For 18850TE GrandStand Revolution Mower with 132cm TURBO FORCE Side Discharge Cutting Unit

Product Name	Model/Part
Turbo Baffle Kit	107-1634
HOC Set Blocks	133-1439
Anti-Scalp Kit, 48/52 Grandstand Deck	133-1440
Oil-Gear, Synthetic, Quart	144-6880
Blade-18.0in, Med Sail	145-3504-03
Blade-18.0in, Recycler	145-3507-03
Kit, Stand-On Weight	147-0200
Recycler Kit	147-0310
Wiring Harness Adapter Kit	147-1612
Soft Bag (3 Bushel)	30104

Notes:



Count on it.