



Count on it.

Parts Catalog

**GrandStand® Revolution® Mower
With 52in TURBO FORCE® Cutting Unit**

Model No. 18560—Serial No. 40000000 and Up



Ordering Replacement Parts

To order replacement parts, please supply the part number, the quantity, and the description of each part desired.

Understanding Reference Numbers

Each identified part in an illustration has a reference number. The reference number for a part also appears in the parts list, along with other information about the part.

This catalog uses two special reference number formats, one to indicate parts in a service assembly and another to indicate the quantity of a given part in an illustration.

Service Assembly Reference Numbers

Parts in service assemblies have reference numbers in the form a:b. The a represents the reference number of the entire service assembly and the b represents a sequential number unique to each part within the service assembly.

For example, a wheel assembly might be identified by reference number 6, the tire by 6:1, the valve by 6:2, and the wheel by 6:3. When you order the assembly identified by reference number 6, you receive all parts identified by reference numbers 6:1, 6:2, and 6:3. However, you may also order any part individually. Reference numbers of this type appear in illustration and in parts lists.

Reference Numbers Indicating Quantity

In an illustration, if a reference number indicates more than one part, the reference number has the form nX y. The n represents the quantity of the part, the X is the multiplication symbol, and the y represents the reference number.

For example, in an illustration, the reference number 2X 37 means that two of the parts identified by reference number 37 are indicated.

Contents

52 Inch Deck Assembly	4
Deck Decal Assembly No. 144-6930	6
Deflector Assembly No. 147-1642	8
Ground Drive Assembly	10
Motion Control Assembly	12
LH Control Handle Assembly No. 144-1421	14
RH Control Handle Assembly No. 144-1422	16
Cover Assembly	18
Deck Lift Assembly	20
RH HOC Pivot Assembly	22
LH HOC Pivot Assembly	24
HOC Level Assembly No. 130-1755	26
HOC Link Assembly No. 130-6615	28
Frame Assembly	30
Platform Assembly	32
Front Caster Assembly	34
Wheel and Bearing Assembly	36
Battery Assembly	38
Electrical Assembly	40
Battery Cable Assembly	42
Control Panel and Harness Assembly	44
Attachments and Accessories	46

52 Inch Deck Assembly

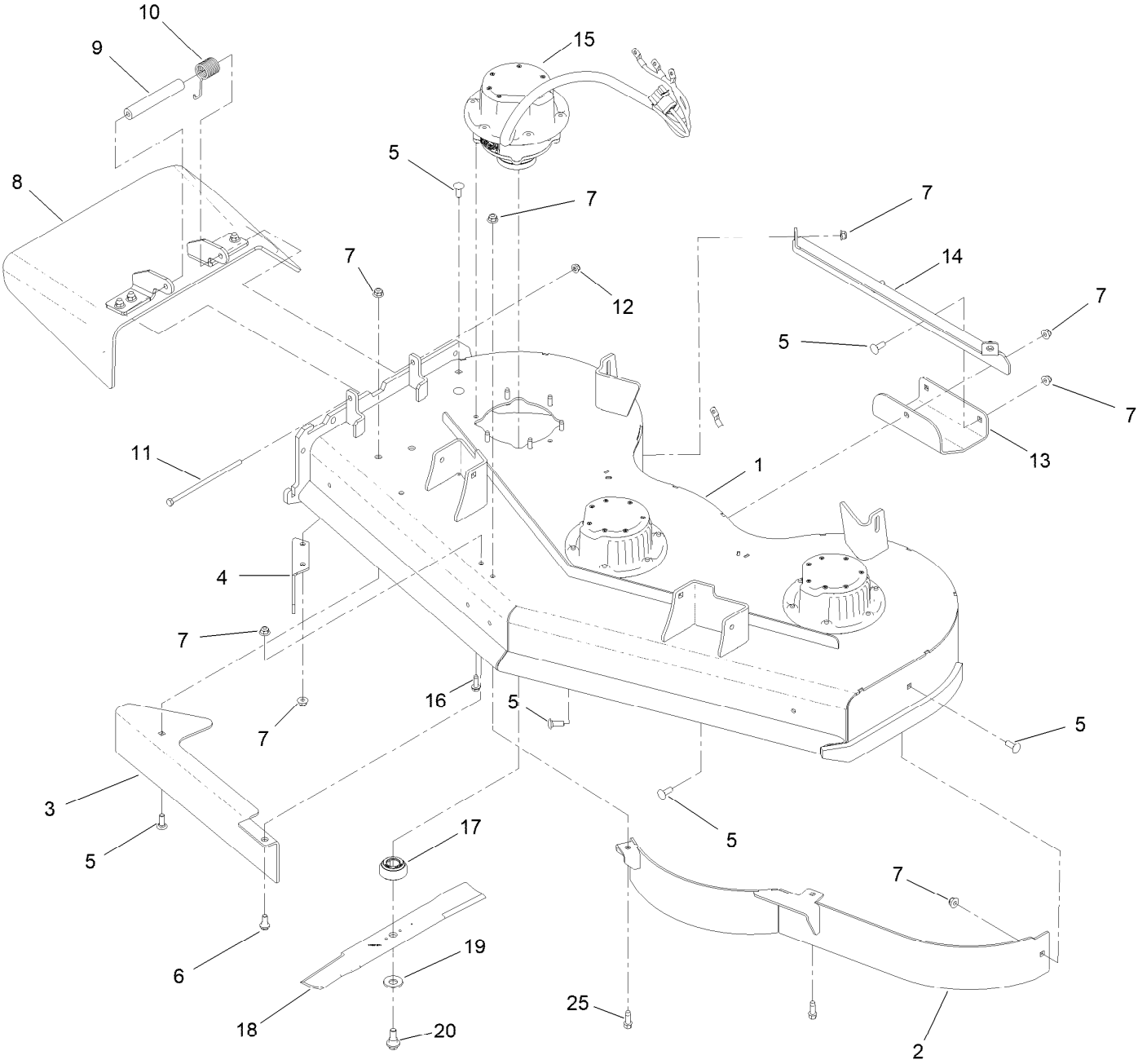

52 Inch Deck Assembly (continued)

<i>Ref.</i>	<i>Part Number</i>	<i>Qty.</i>	<i>Description</i>	<i>Ref.</i>	<i>Part Number</i>	<i>Qty.</i>	<i>Description</i>
1	144-6930	1	Deck ASM, 52In	12	104-8300	1	Nut-HF, NI
2	144-3805-01	1	Baffle ASM, Front [red]	13	114-1908-01	1	Skid
3	139-8105-01	1	Plate-Baffle, Formed [red]	14	130-6648-01	1	Bracket-Skid
4	130-6594-01	1	Baffle-Discharge	15	147-1689	1	Motor/Gen
5	3231-22	9	Screw-CARR	16	701243	18	Screw-Thd Roll, HWH
6	94-7582	1	Bolt-Shoulder	17	145-3439	3	Retainer-Blade
7	104-8301	12	Nut-HF, NI	18	145-3504-03	3	Blade-18.0In, Med Sail
8	147-1642	1	Rubber Deflector ASM	19	125-1736	3	Washer-Belleville
9	105-4622	1	Spacer	20	145-3499	3	Screw-Shoulder, HWH
10	108-4052	1	Spring-Torsion	25	92-1624	2	Screw-HWH Thd Form
11	322-50	1	Screw-HH				

Deck Decal Assembly No. 144-6930

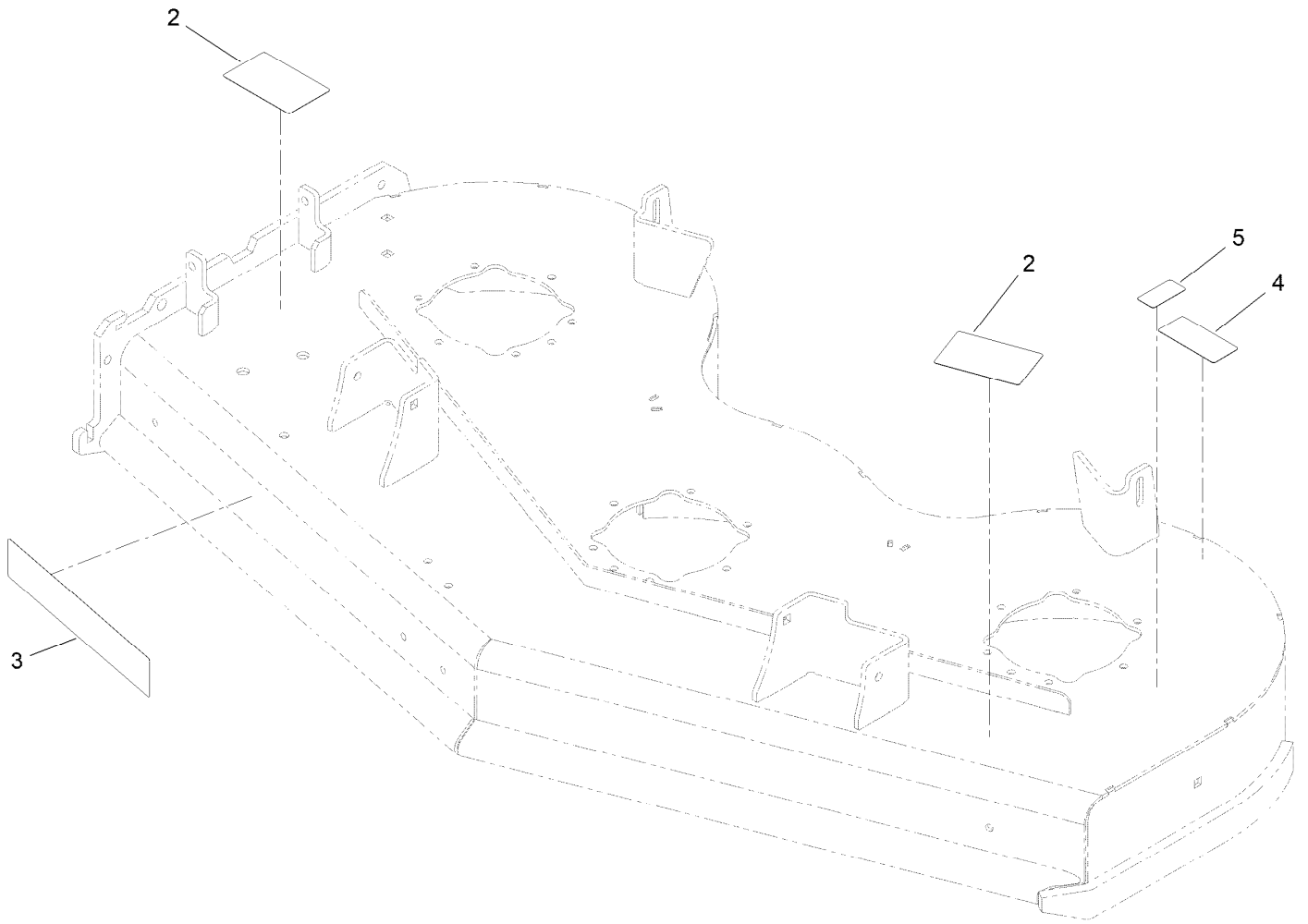

Deck Decal Assembly No. 144-6930 (continued)

<i>Ref.</i>	<i>Part Number</i>	<i>Qty.</i>	<i>Description</i>	<i>Ref.</i>	<i>Part Number</i>	<i>Qty.</i>	<i>Description</i>
2	144-7006	2	Decal-Danger, CE	4	147-0288	1	Decal-Danger
3	107-1618	1	Decal	5	137-8127	1	Decal-No Spray

Deflector Assembly No. 147-1642

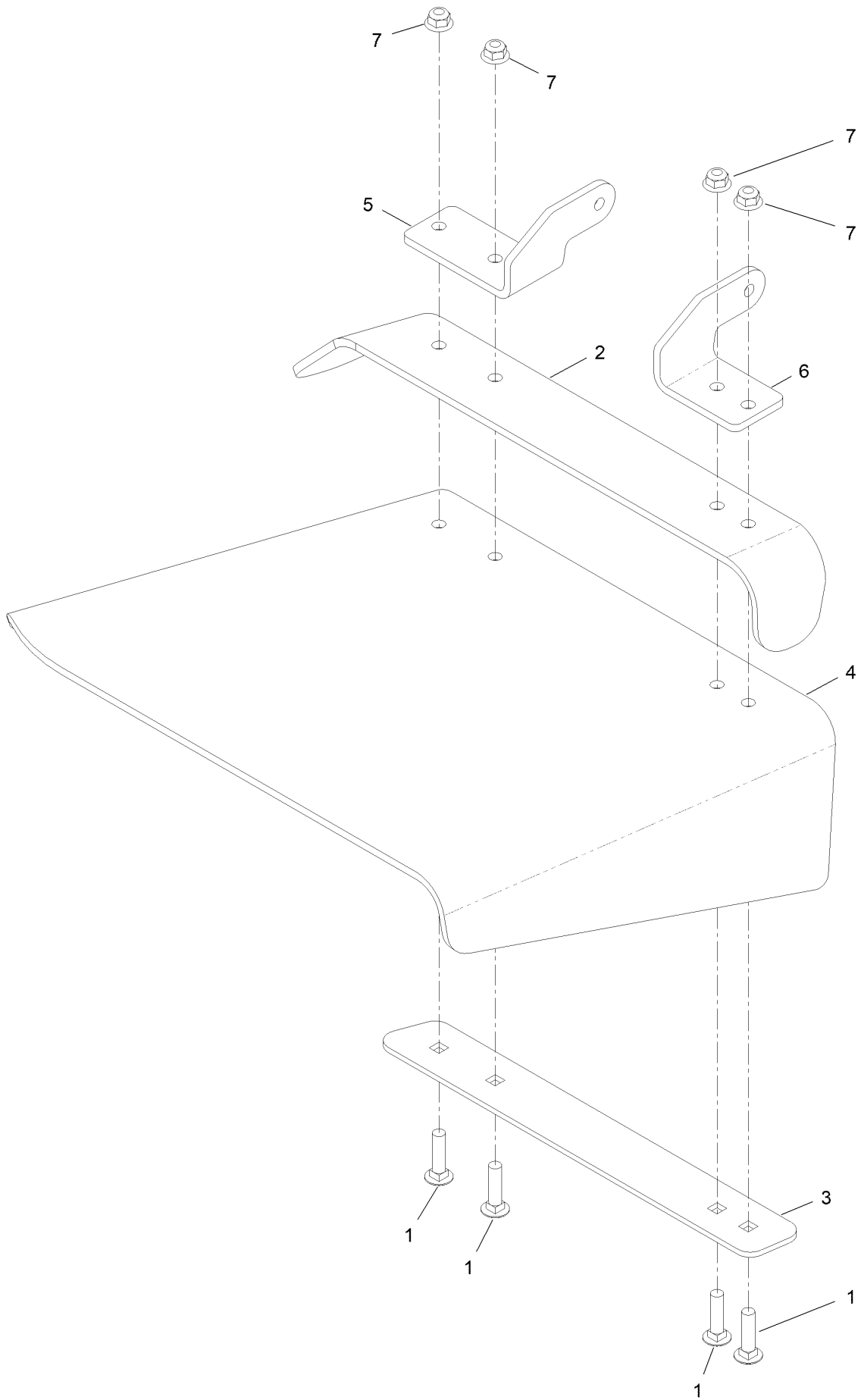

Deflector Assembly No. 147-1642 (continued)

<i>Ref.</i>	<i>Part Number</i>	<i>Qty.</i>	<i>Description</i>	<i>Ref.</i>	<i>Part Number</i>	<i>Qty.</i>	<i>Description</i>
1	3231-4	4	Screw-CARR	5	147-0386-01	1	Plate-Hinge, Rear
2	106-3246-01	1	Deflector	6	147-0387-01	1	Plate-Hinge, Front
3	106-3248-03	1	Strap-Discharge	7	104-8301	4	Nut-HF, NI
4	139-8114	1	Deflector-Deck, Rubber				

Ground Drive Assembly

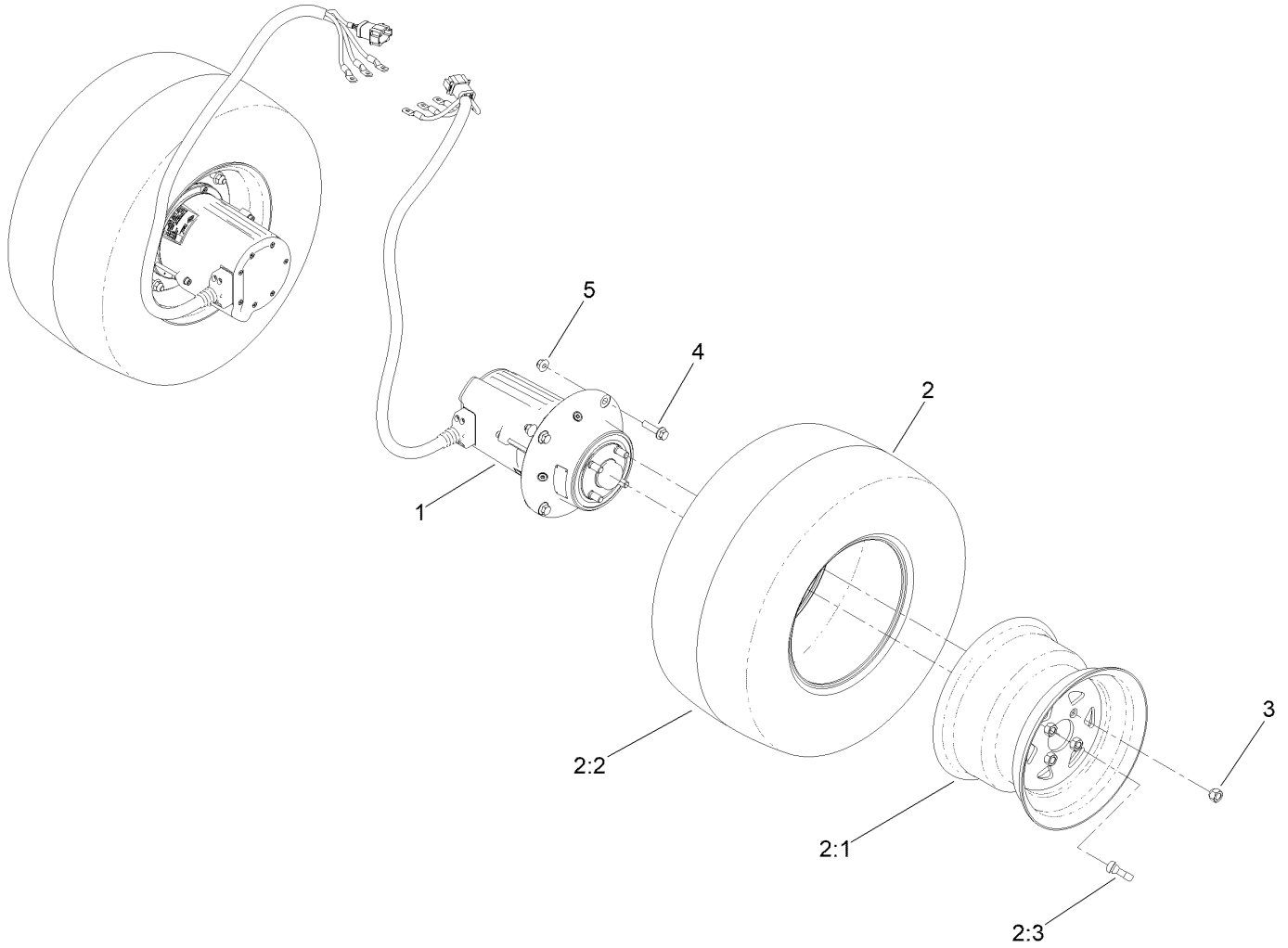

Ground Drive Assembly (continued)

<i>Ref.</i>	<i>Part Number</i>	<i>Qty.</i>	<i>Description</i>	<i>Ref.</i>	<i>Part Number</i>	<i>Qty.</i>	<i>Description</i>
1	147-1688	1	Motor/Gearbox ASM-48V,	2:3	232-27	1	Stem-Valve
2	144-3846	2	Wheel And Tire ASM	3	242-35	8	Nut-Wheel
2:1	144-3847	1	Rim-10 In	4	114-4681	8	Screw-HHF
2:2	144-1519	1	Tire	5	104-8301	8	Nut-HF, NI

Motion Control Assembly

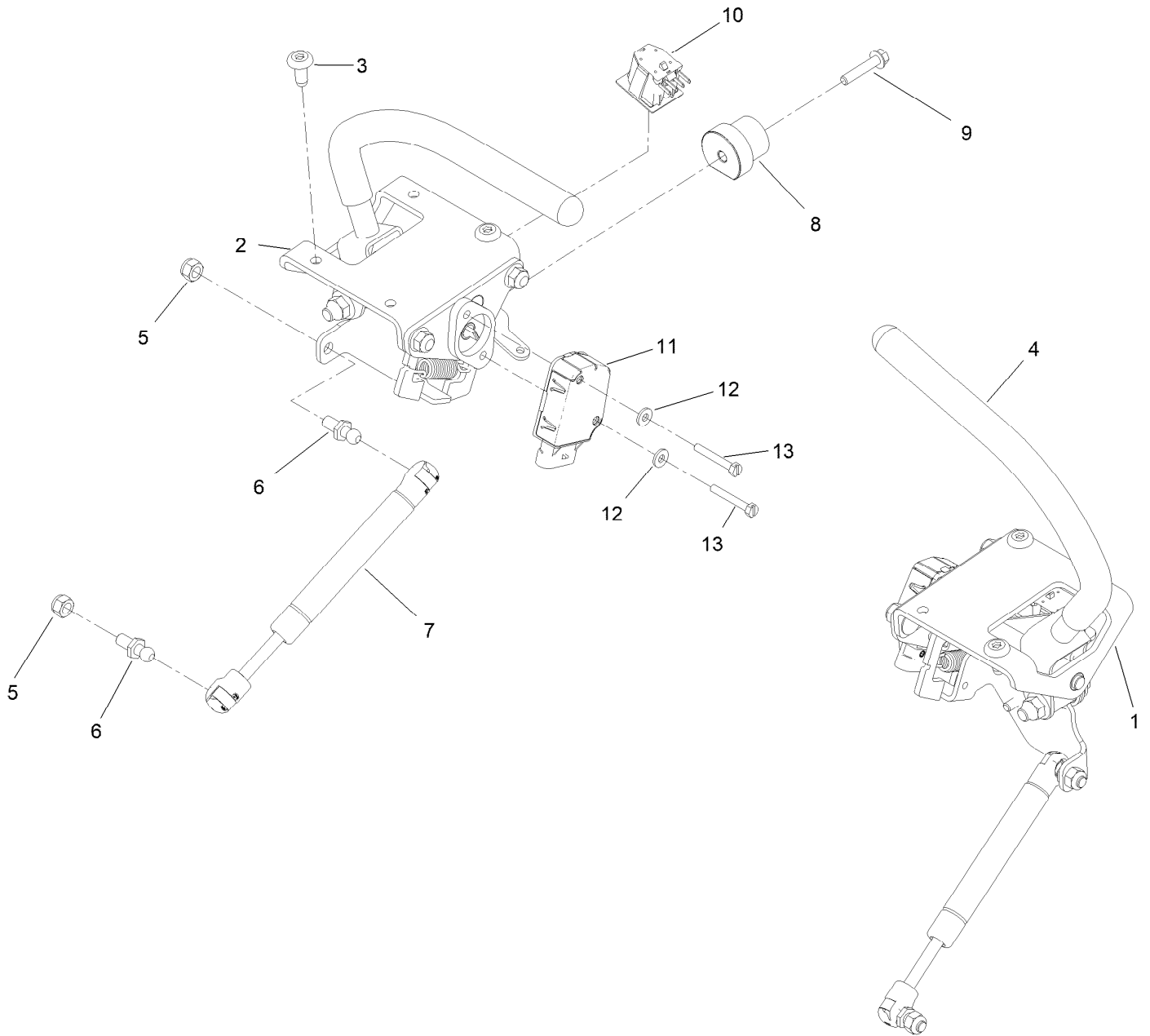

Motion Control Assembly (continued)

<i>Ref.</i>	<i>Part Number</i>	<i>Qty.</i>	<i>Description</i>	<i>Ref.</i>	<i>Part Number</i>	<i>Qty.</i>	<i>Description</i>
1	144-1421	1	Control Handle ASM, LH	8	126-1499	2	Cam
2	144-1422	1	Control Handle ASM, RH	9	32144-110	2	Screw-HWH
3	138-9753	4	Screw	10	145-3520	2	Switch-Plunger, On-(On)
4	119-0222	2	Grip	11	122-0917	2	Sensor-Position
5	138-8401	4	Nut-HF	12	3256-14	4	Washer-Flat
6	103-5752	4	Stud-Ball	13	32105-1	4	Screw-SHH
7	139-1523	2	Damper				

LH Control Handle Assembly No. 144-1421

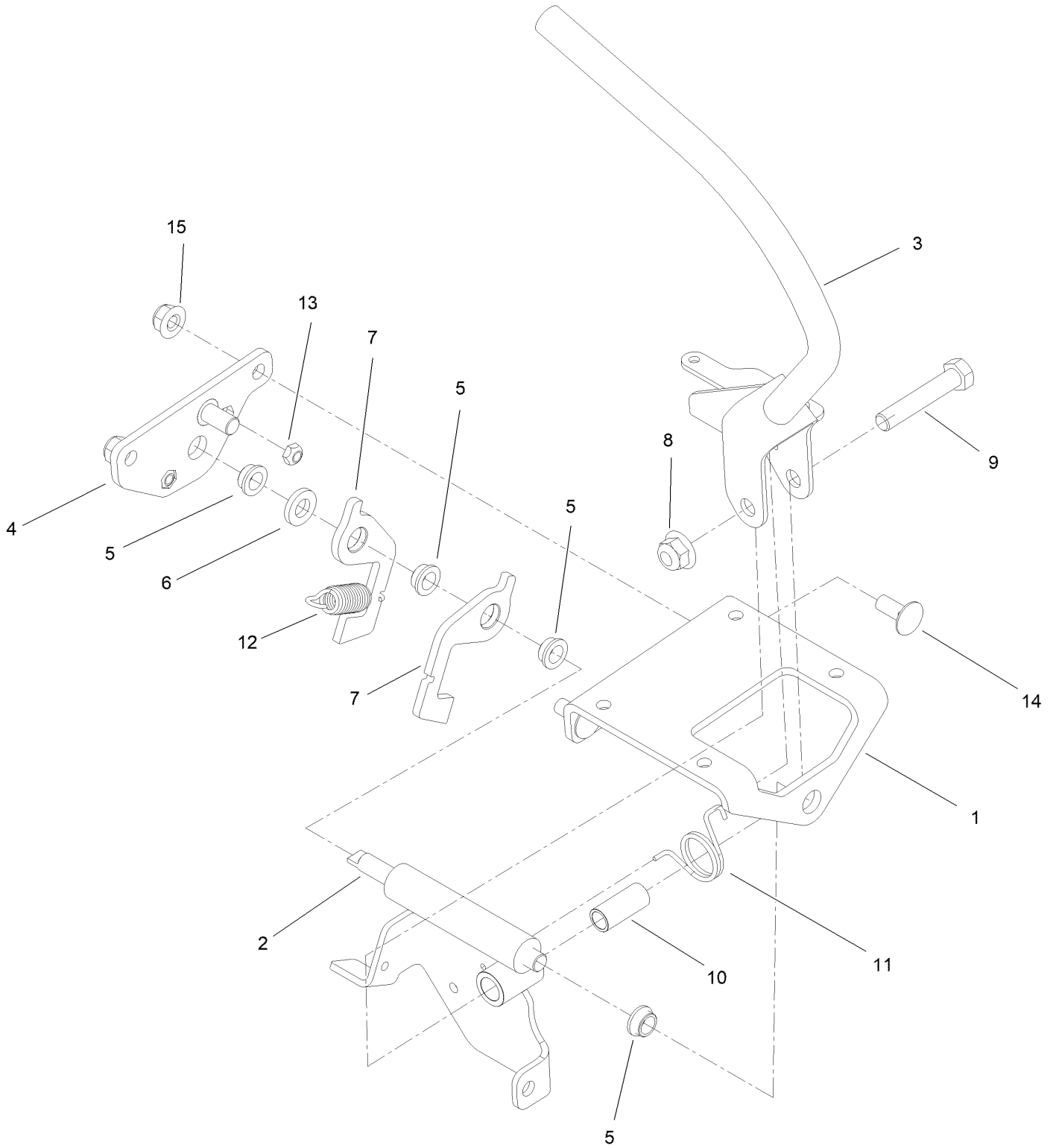

LH Control Handle Assembly No. 144-1421 (continued)

<i>Ref.</i>	<i>Part Number</i>	<i>Qty.</i>	<i>Description</i>	<i>Ref.</i>	<i>Part Number</i>	<i>Qty.</i>	<i>Description</i>
1	144-1427	1	Bracket-Control Mount	9	323-10	1	Screw-HH
2	145-3585	1	Motion Control ASM LH	10	131-3562	1	Bearing-Sleeve
3	145-3579	1	LH Lever ASM	11	139-1508	1	Spring-Torsion
4	144-1491	1	Plate ASM-Sensor LH	12	139-2859	1	Spring-Extension
5	139-1525	4	Bushing-Flanged Nylon	13	3296-12	2	Nut-Lock, NI
6	139-6293	1	Washer	14	3230-23	2	Bolt-CARR
7	139-1513	2	Plate-Spring	15	104-8300	2	Nut-HF, NI
8	104-8301	1	Nut-HF, NI				

RH Control Handle Assembly No. 144-1422

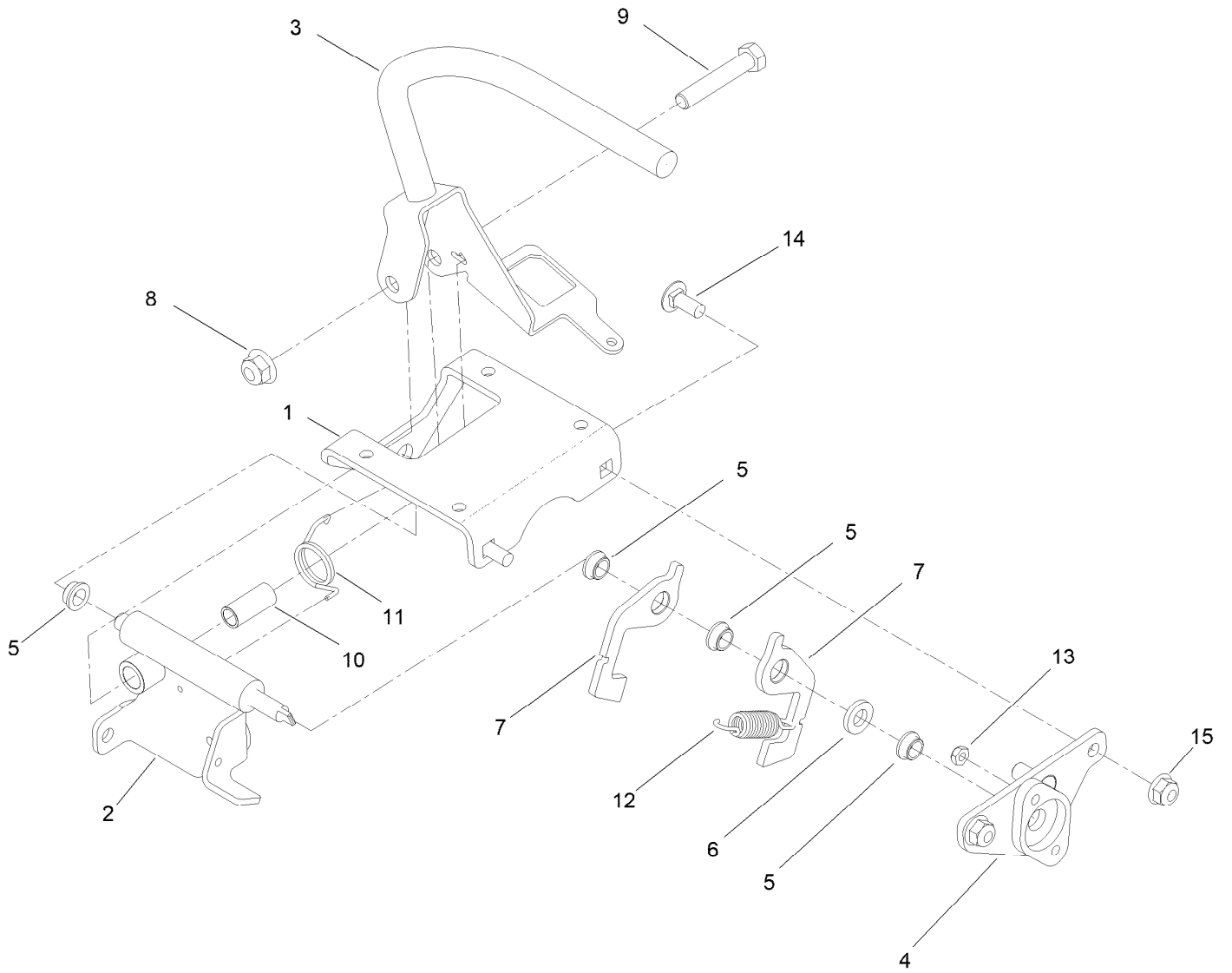

RH Control Handle Assembly No. 144-1422 (continued)

<i>Ref.</i>	<i>Part Number</i>	<i>Qty.</i>	<i>Description</i>	<i>Ref.</i>	<i>Part Number</i>	<i>Qty.</i>	<i>Description</i>
1	144-1427	1	Bracket-Control Mount	9	323-10	1	Screw-HH
2	145-3586	1	Motion Control ASM RH	10	131-3562	1	Bearing-Sleeve
3	145-3580	1	RH Lever ASM	11	139-1538	1	Spring-Torsion
4	144-1510	1	Plate ASM-Sensor RH	12	139-2859	1	Spring-Extension
5	139-1525	4	Bushing-Flanged Nylon	13	3296-12	2	Nut-Lock, NI
6	139-6293	1	Washer	14	3230-23	2	Bolt-CARR
7	139-1513	2	Plate-Spring	15	104-8300	2	Nut-HF, NI
8	104-8301	1	Nut-HF, NI				

Cover Assembly

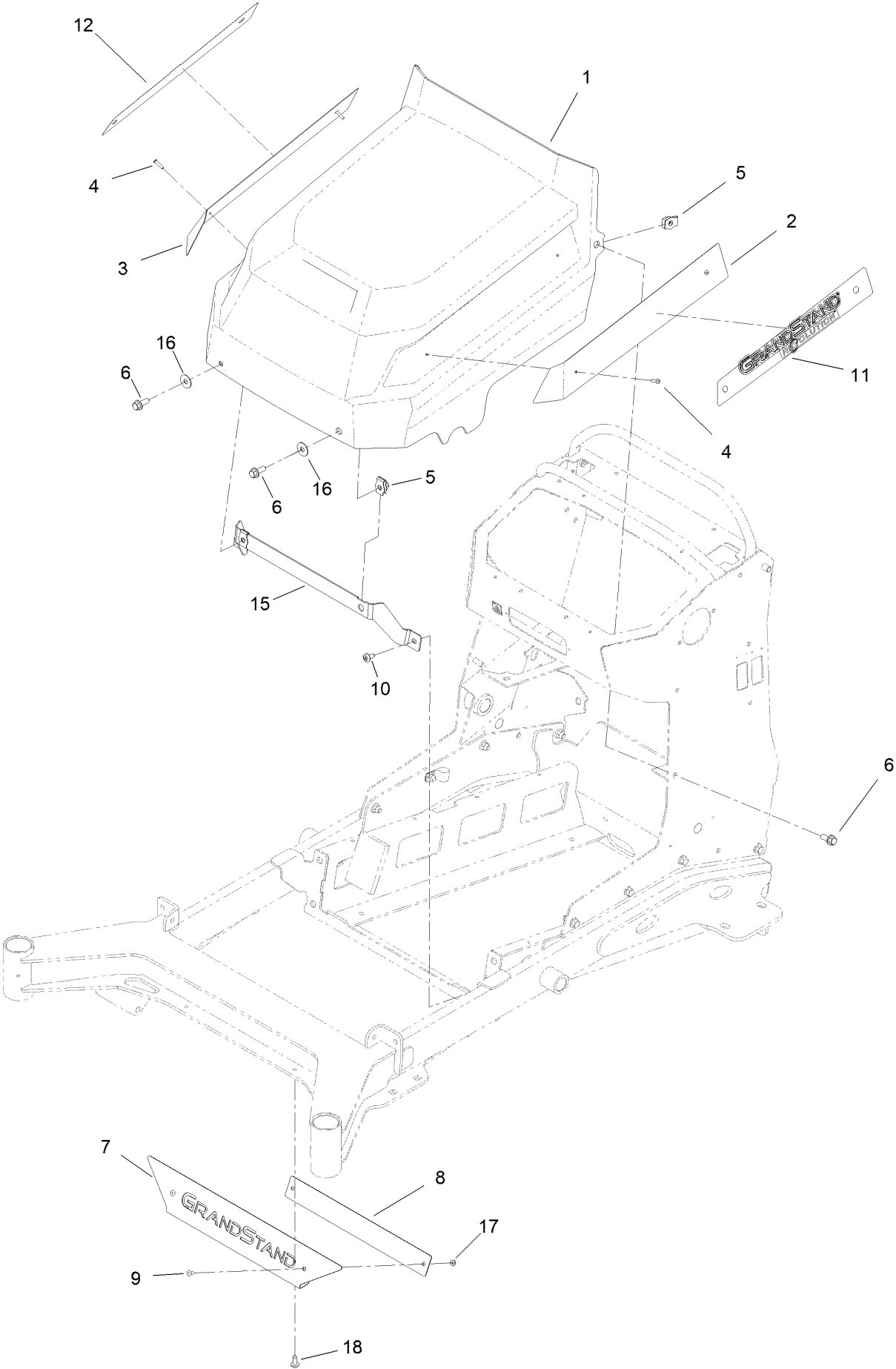

Cover Assembly (continued)

<i>Ref.</i>	<i>Part Number</i>	<i>Qty.</i>	<i>Description</i>	<i>Ref.</i>	<i>Part Number</i>	<i>Qty.</i>	<i>Description</i>
1	144-6896	1	Cover-Battery	9	114439	2	Rivet-Blind
2	144-6899	1	Plate-Insert, Cover	10	138-9753	2	Screw
3	144-6901	1	Plate-Insert, Cover	11	144-7007	1	Decal-Lithium Left
4	130-8451	4	Rivet-Trifold	12	144-7014	1	Decal-Lithium Right
5	105-4886	4	Nut-Tinnerman	15	144-6894-03	1	Bracket-Mount, Cover
6	3234-42	4	Screw-HHF	16	52-2860	2	Washer
7	144-7024-03	1	Plate-Front, Egrandstand	17	3269-26	2	Washer-Plain
8	144-7028	1	Plate-Cover	18	92-1624	2	Screw-HWH Thd Form

Deck Lift Assembly

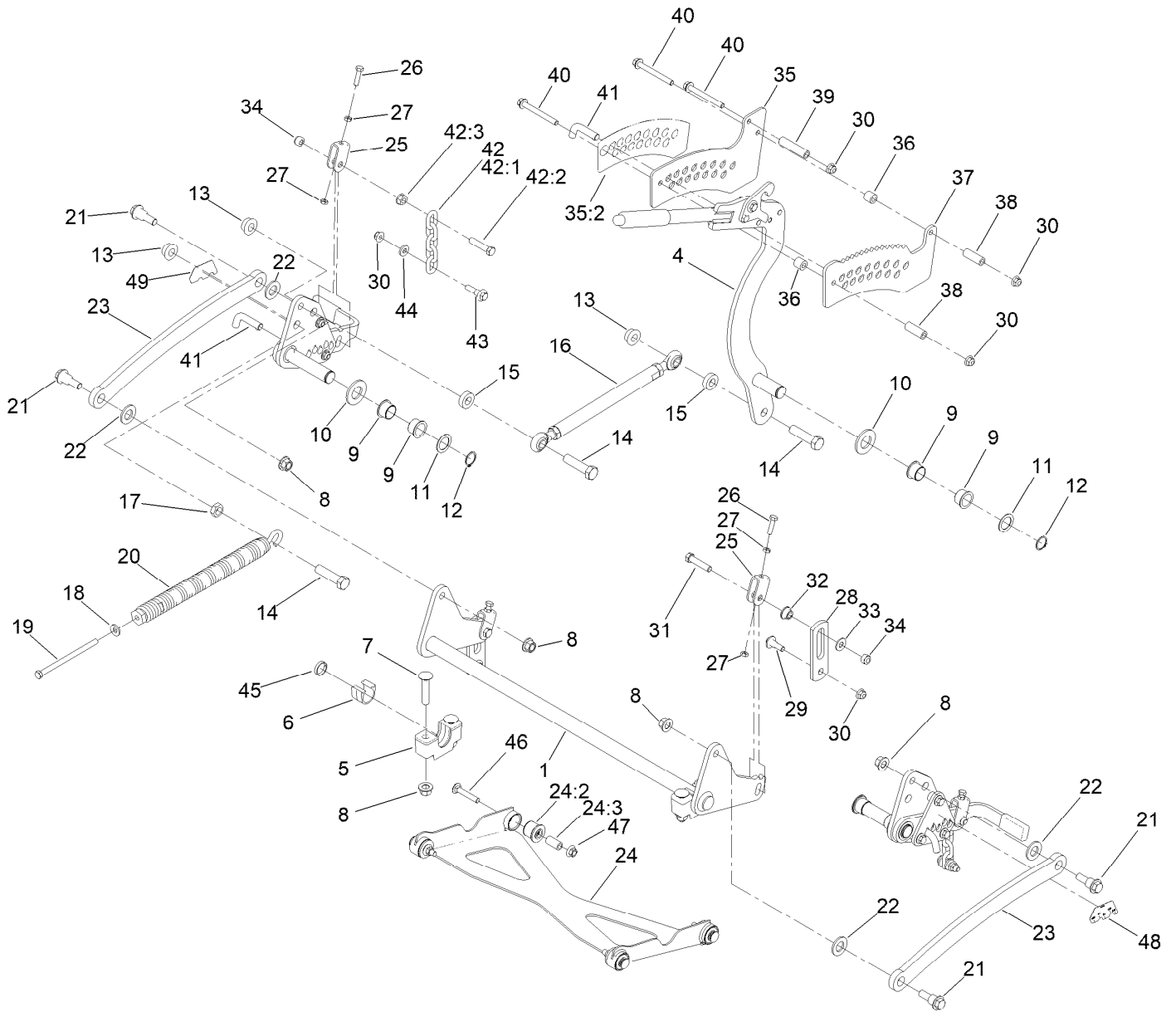

Deck Lift Assembly (continued)

<i>Ref.</i>	<i>Part Number</i>	<i>Qty.</i>	<i>Description</i>	<i>Ref.</i>	<i>Part Number</i>	<i>Qty.</i>	<i>Description</i>
1	120-8405-01	1	Shaft-Cross, Front	27	3218-2	8	Nut-Hex Jam
4	130-1755	1	HOC Lever ASM	28	130-6589	2	Link-Lift
5	109-9409	2	Support-Bearing, Cross Shaft (Front)	29	109-9840	2	Screw-Shoulder, HHF
6	109-9410	2	Bearing-Cross Shaft, Front	30	104-8301	7	Nut-HF, NI
7	116-1700	4	Bolt-CARR	31	109-9065	2	Screw-HH
8	99-5107	8	Nut-Lock	32	116-2428	2	Bushing-Flanged
9	127-0369	6	Bushing	33	3256-4	4	Washer-Flat
10	3256-62	3	Washer-Flat	34	3296-48	4	Nut-Hex
11	10-8110	3	Washer-Thrust	35	147-1687	1	HOC Plate And Decal ASM
12	32151-29	3	Ring-Retaining	35:2	147-1681	1	Decal-HOC
13	138-4932	3	Nut-Hex Flg	36	121-1760	2	Spacer
14	138-4931	3	Screw-Lock	37	138-4887	1	Plate-HOC, Inner
15	119-6223	2	Washer	38	95-6448	2	Spacer
16	130-6615	1	HOC Link ASM	39	138-1111	1	Spacer
17	3218-6	1	Nut-Jam	40	116-4701	3	Screw-HHF
18	98-5975	1	Washer-Belleville	41	138-7203	3	Pin-HOC
19	323-58	1	Bolt-TAP, HH	42	116-0756	2	Deck Lift Chain ASM
20	116-0886	1	Spring-Extension	42:1	1-633447	1	Chain-Lift, Deck
21	116-0780	4	Screw-Shoulder, HHF	42:2	109-9065	1	Screw-HH
22	3256-28	4	Washer-Flat	42:3	32128-37	1	Nut-HF
23	127-1948-03	2	Link-Lift	43	130-0742	2	Bolt-Shoulder
24	137-4129	1	Deck Strut ASM	44	43-0940	2	Spacer
24:2	137-4108	4	Bushing-Rubber	45	133-1431	1	Spacer-Split
24:3	108-6544	4	Spacer	46	3231-7	4	Screw-CARR
25	109-9066	4	Yoke-Adjust, Deck	47	32128-19	4	Nut-HF Lock, Large Flg
26	322-47	4	Screw-HH	48	144-1572	1	Decal-Deck Rake, LH
				49	144-1573	1	Decal-Deck Rake, RH

RH HOC Pivot Assembly

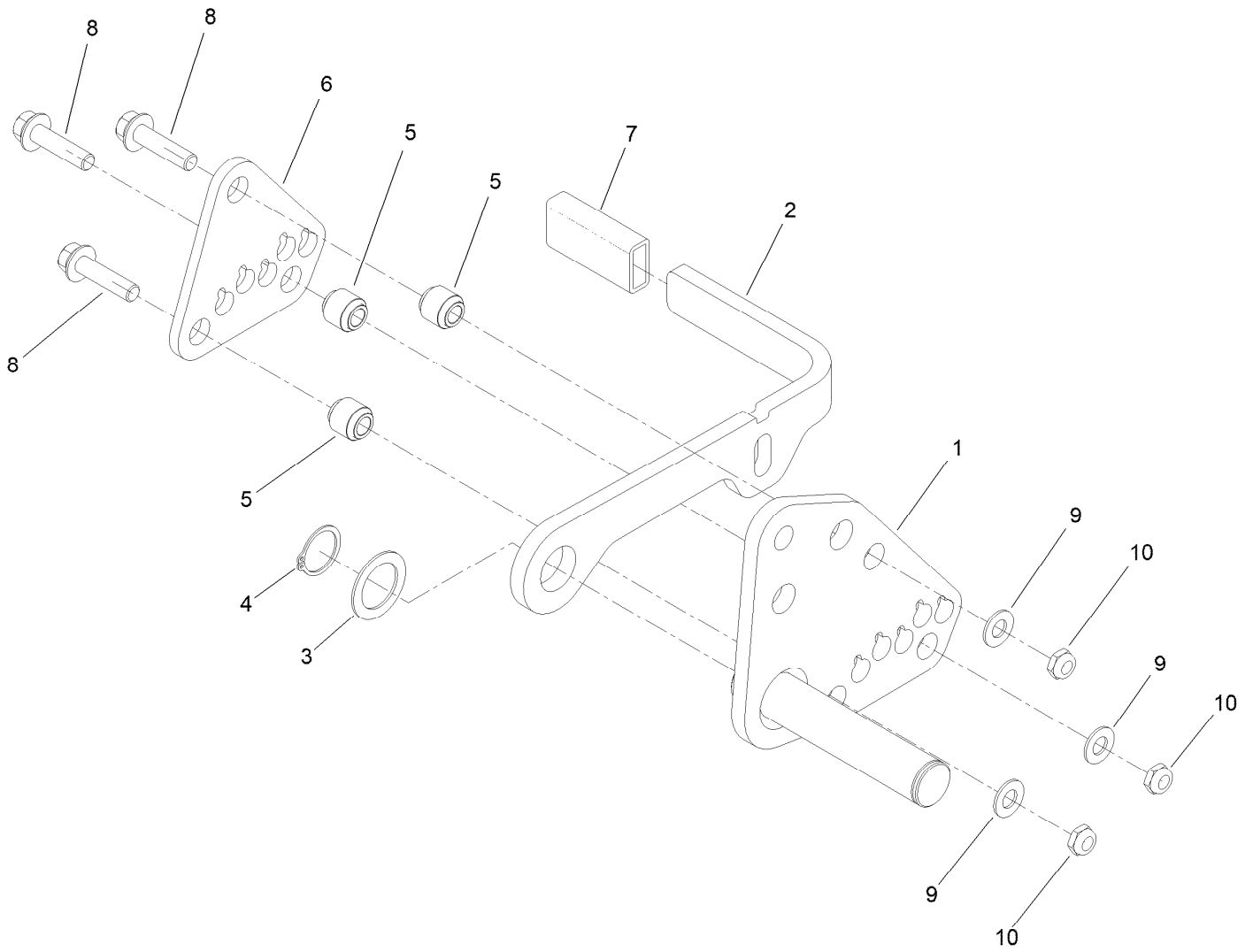

RH HOC Pivot Assembly (continued)

<i>Ref.</i>	<i>Part Number</i>	<i>Qty.</i>	<i>Description</i>	<i>Ref.</i>	<i>Part Number</i>	<i>Qty.</i>	<i>Description</i>
1	144-1550-01	1	Pivot ASM-RH HOC [red]	6	144-1553-01	1	Plate-Rake Adj, Outer
2	144-1547-01	1	Lever-Rake, Deck [red]	7	116-4312	1	Grip-Flat
3	10-8110	1	Washer-Thrust	8	114-4681	3	Screw-HHF
4	32151-29	1	Ring-Retaining	9	48-9220	3	Washer-Flat
5	138-7201	3	Spacer-Double Step	10	3296-59	3	Nut-Lock, NI

LH HOC Pivot Assembly

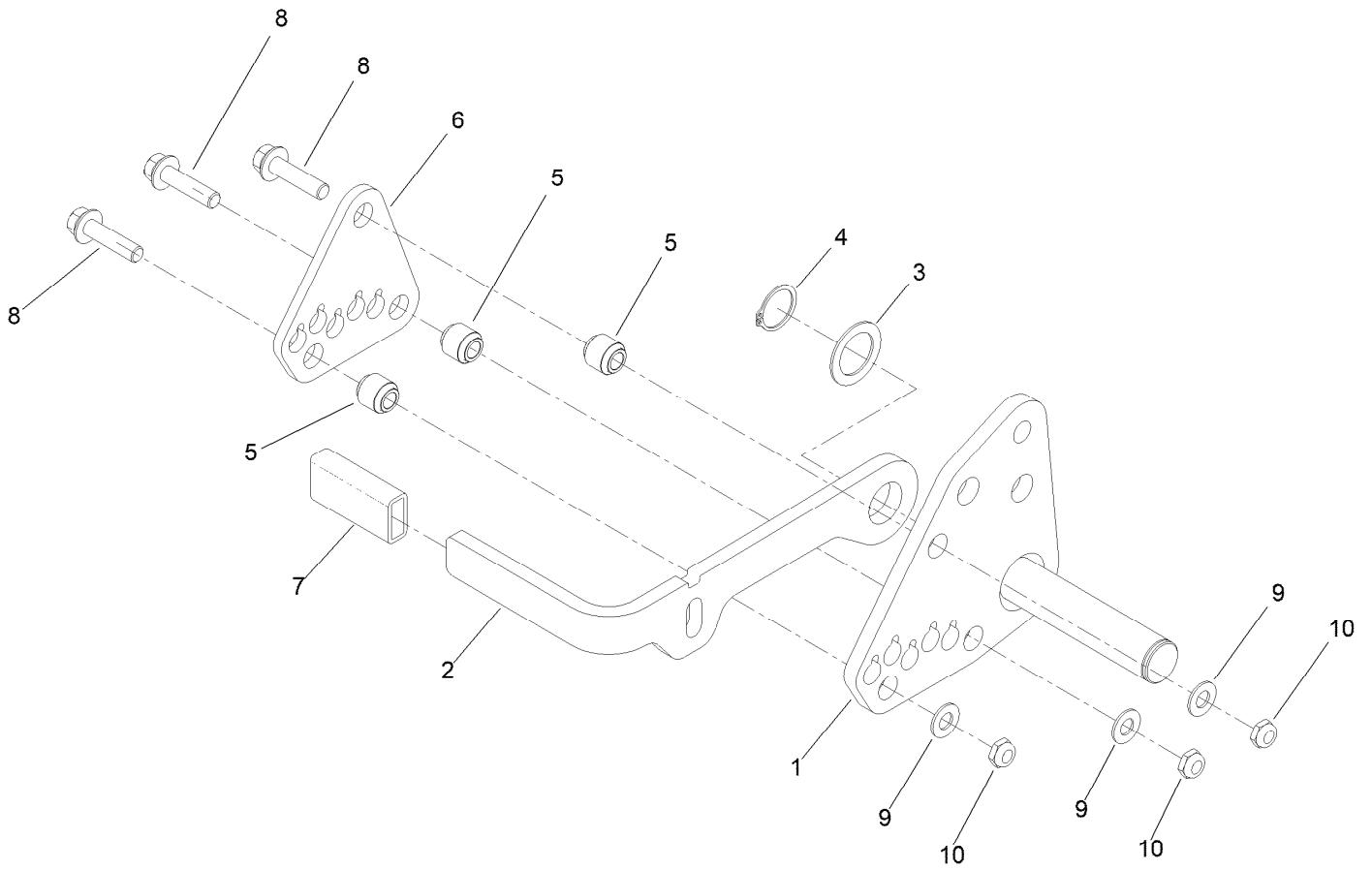

LH HOC Pivot Assembly (continued)

<i>Ref.</i>	<i>Part Number</i>	<i>Qty.</i>	<i>Description</i>	<i>Ref.</i>	<i>Part Number</i>	<i>Qty.</i>	<i>Description</i>
1	144-1556-01	1	Pivot ASM-LH HOC [red]	6	144-1553-01	1	Plate-Rake Adj, Outer
2	144-1558-01	1	Lever-Rake, Deck [red]	7	116-4312	1	Grip-Flat
3	10-8110	1	Washer-Thrust	8	114-4681	3	Screw-HHF
4	32151-29	1	Ring-Retaining	9	48-9220	3	Washer-Flat
5	138-7201	3	Spacer-Double Step	10	3296-59	3	Nut-Lock, NI

HOC Level Assembly No. 130-1755

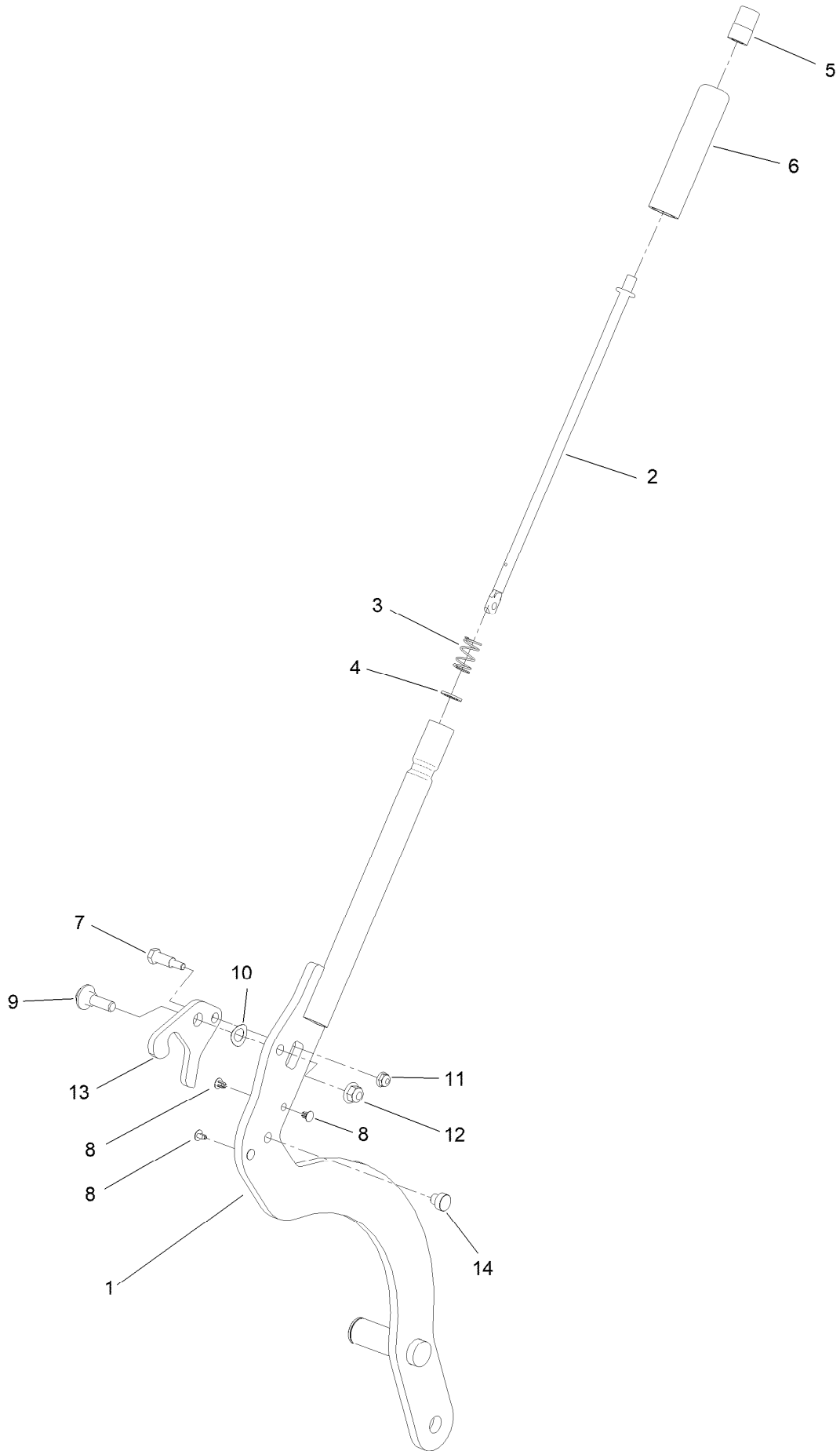

HOC Level Assembly No. 130-1755 (continued)

<i>Ref.</i>	<i>Part Number</i>	<i>Qty.</i>	<i>Description</i>	<i>Ref.</i>	<i>Part Number</i>	<i>Qty.</i>	<i>Description</i>
1	130-1775-01	1	Lever-Lift	8	103-1363	4	Rivet
2	136-0530	1	Rod-Latch, Release	9	614672	1	Screw-Shoulder, HWH
3	114-8187	1	Spring-Compression	10	110-8982	1	Washer-Spring
4	114-1207	1	Washer-Special	11	104-7201	1	Nut-HF, NI
5	115-2750	1	Knob	12	104-8301	1	Nut-HF, NI
6	115-3592	1	Grip	13	138-4888	1	Latch-HOC
7	119-2309	1	Bolt-Shoulder	14	138-4863	1	Plug-Wear

HOC Link Assembly No. 130-6615

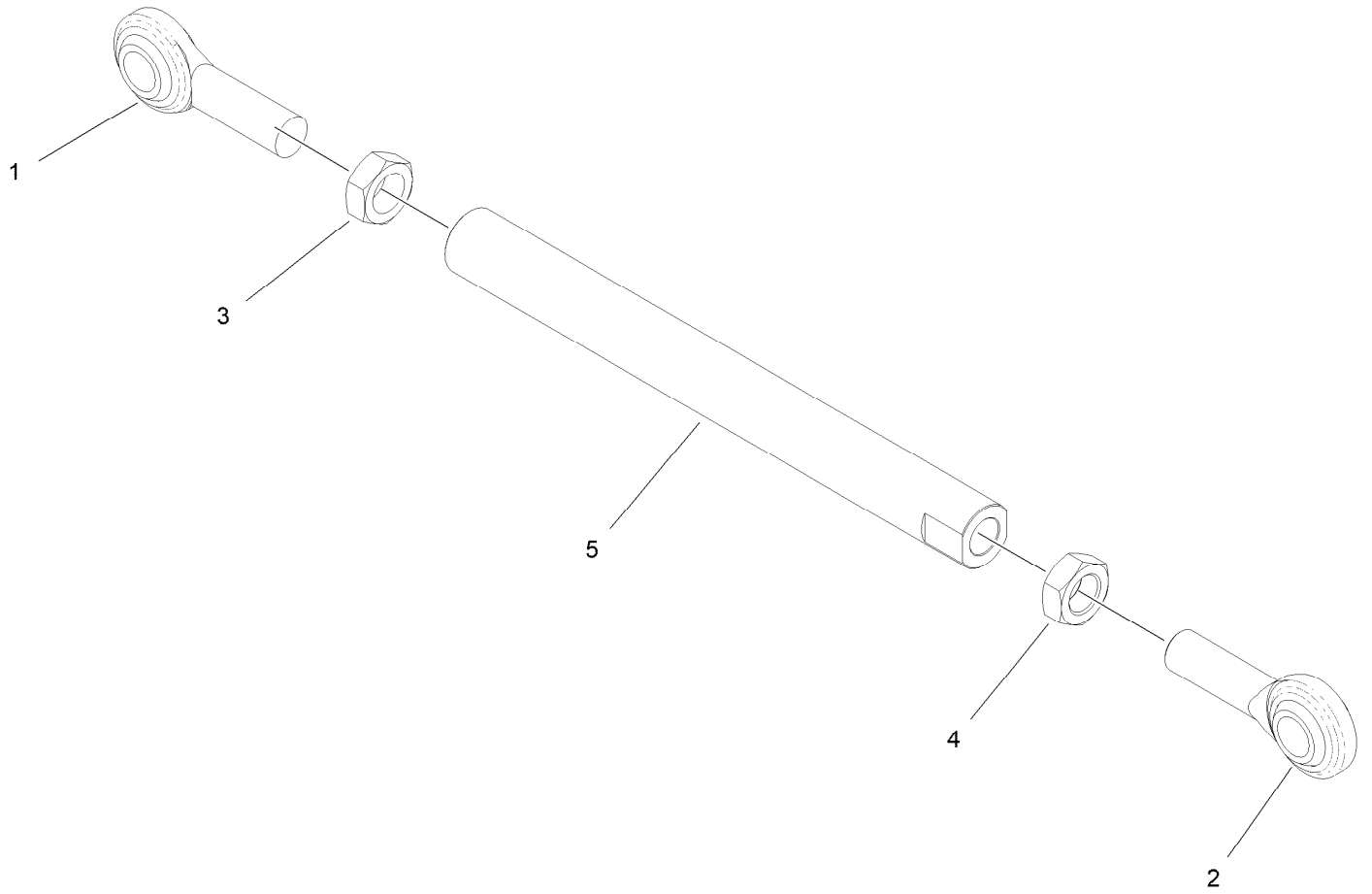

HOC Link Assembly No. 130-6615 (continued)

<i>Ref.</i>	<i>Part Number</i>	<i>Qty.</i>	<i>Description</i>
1	1-633029	1	Balljoint-Spherical
2	117-5291	1	Balljoint-Spherical
3	3220-6	1	Nut-Jam

<i>Ref.</i>	<i>Part Number</i>	<i>Qty.</i>	<i>Description</i>
4	117-5293	1	Nut-Jam
5	130-6614	1	Link-Height Of Cut

Frame Assembly

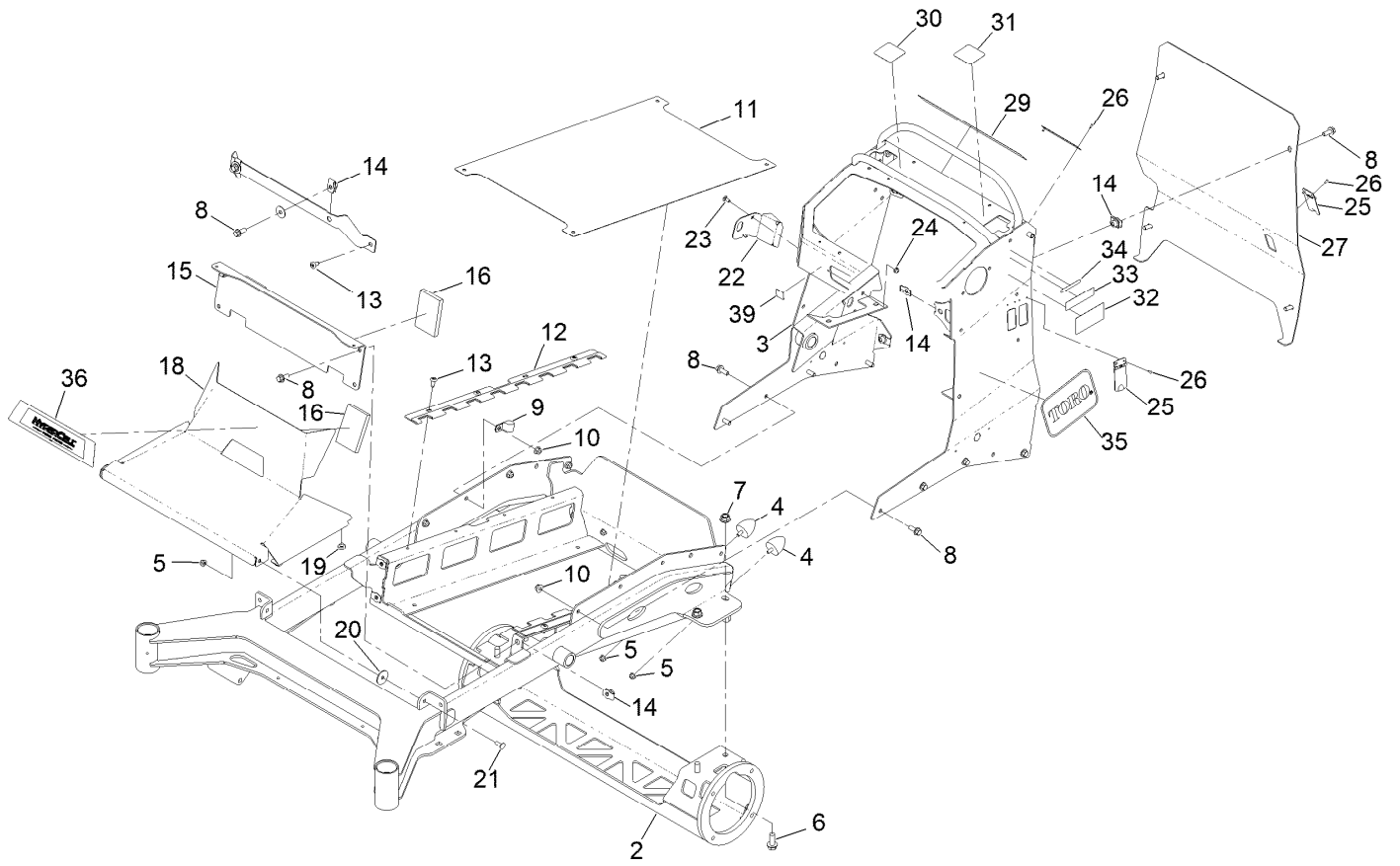

Frame Assembly (continued)

<i>Ref.</i>	<i>Part Number</i>	<i>Qty.</i>	<i>Description</i>	<i>Ref.</i>	<i>Part Number</i>	<i>Qty.</i>	<i>Description</i>
2	144-3840-01	1	Frame-Axle ASM [red]	20	107-3002	2	Washer-Nylon
3	144-1580	1	Tower ASM	21	3230-10	2	Bolt-CARR
4	114-1926	4	Bumper-Rubber	22	144-6862	1	Plate-Latch
5	104-8300	6	Nut-HF, NI	23	3229-11	1	Screw-CARR
6	3234-38	4	Screw-HHF	24	104-7201	1	Nut-HF, NI
7	99-5107	4	Nut-Lock	25	144-6628	2	Plate-Cover, Spring
8	3234-42	14	Screw-HHF	26	3290-271	6	Rivet-Pop
9	2412-4	2	Clamp-R	27	144-3876-03	1	Plate-Cover, Plate
10	104-8301	8	Nut-HF, NI	29	144-7002	1	Decal-Warning
11	145-3403-03	1	Plate-Skid	30	144-7004	1	Decal-OPC Control, Right
12	144-3874-03	2	Bracket-Retention, Battery	31	144-7003	1	Decal-OPC Control, Left
13	138-9753	6	Screw	32	147-0289	1	Decal-Charging Port
14	105-4886	10	Nut-Tinnerman	33	144-7008	1	Decal-Service, Shut-Off
15	144-6957-03	1	Plate-Battery Mnt	34	133-8061	1	Decal-Warning
16	100-2196	3	Pad-Foam	35	145-3437	2	Decal-Toro Logo
18	144-7023-03	1	Cover-Motor Controller	36	144-7015	1	Decal-Hypercell 1900
19	1-513658	4	Bumper	39	147-0290	1	Decal-Light, Warning

Platform Assembly

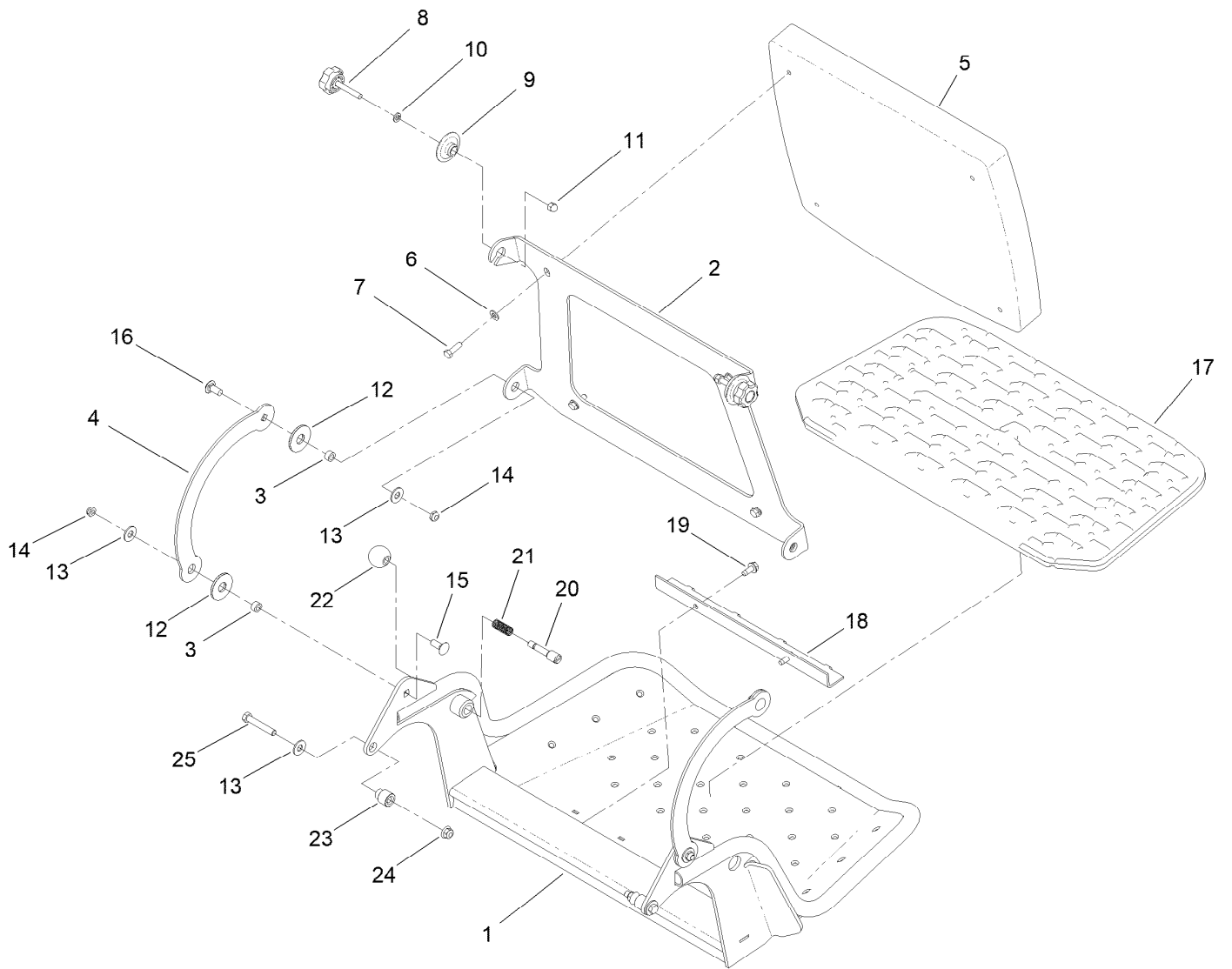

Platform Assembly (continued)

<i>Ref.</i>	<i>Part Number</i>	<i>Qty.</i>	<i>Description</i>	<i>Ref.</i>	<i>Part Number</i>	<i>Qty.</i>	<i>Description</i>
1	120-8475-01	1	Platform	14	3296-59	4	Nut-Lock, NI
2	120-8499-03	1	Hinge-Pad	15	3231-2	2	Bolt-CARR
3	111044	4	Spacer	16	3231-27	2	Screw-CARR
4	114-1915-01	2	Link-Pad	17	144-6958	1	Mat, Platform
5	145-3535	1	Cushion Pad ASM	18	114-1920-03	1	Clamp-Shield
6	3256-23	4	Washer-Plain	19	32144-70	2	Screw-HWHTF
7	121-7999	4	Screw-HH	20	119-8650	1	Pin-Latch
8	133-1426	2	Knob	21	114-5348	1	Spring
9	116-2886	2	Slide-Bushing	22	1-603175	1	Knob-Ball
10	3253-4	2	Washer-Lock	23	132-7583	2	Bushing-Flanged
11	131-4535	2	Nut-Acorn	24	104-8301	2	Nut-HF, NI
12	114-0463	4	Washer-Friction, Composite	25	323-45	2	Screw-HH
13	3256-4	6	Washer-Flat				

Front Caster Assembly

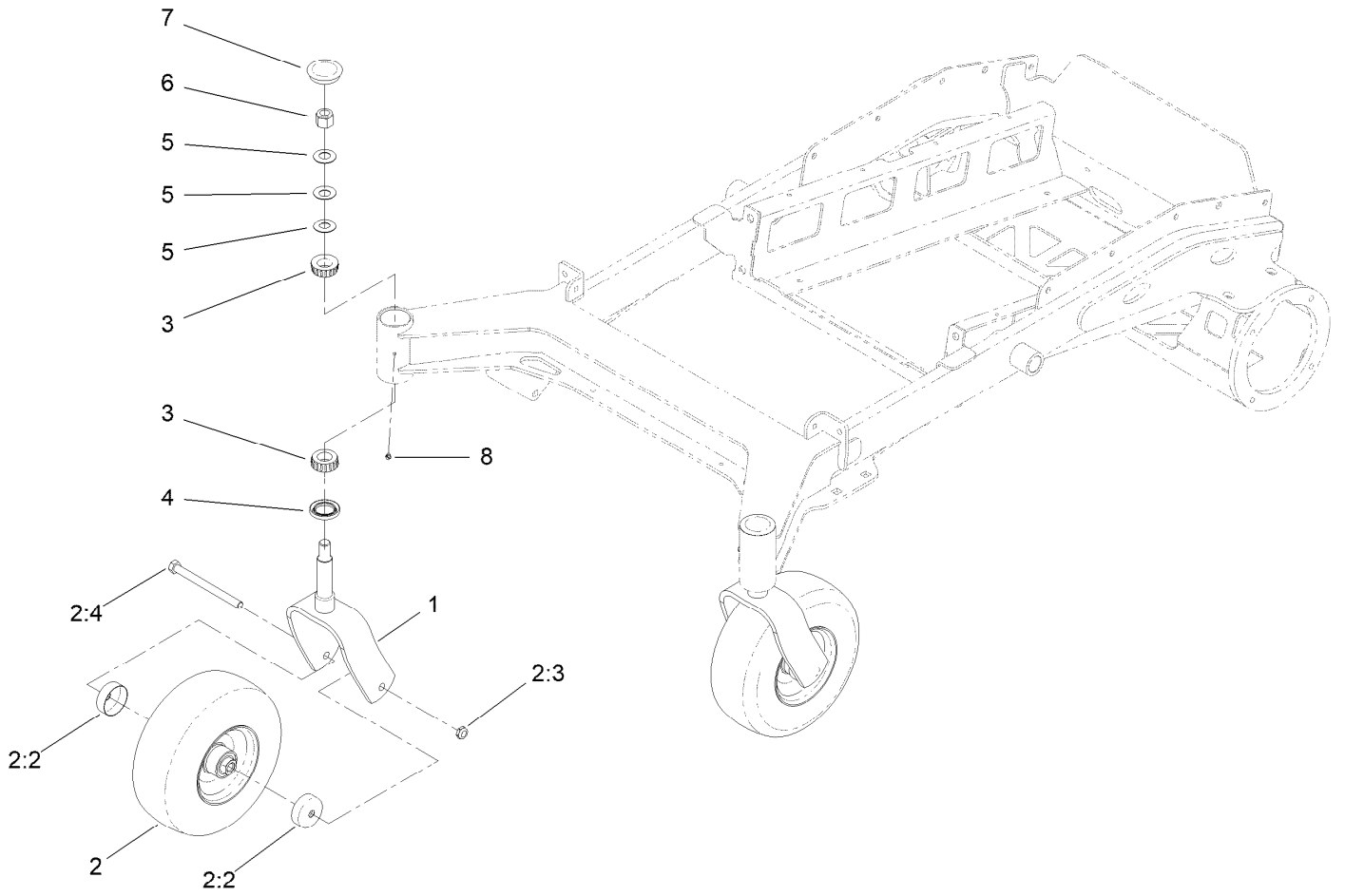

Front Caster Assembly (continued)

<i>Ref.</i>	<i>Part Number</i>	<i>Qty.</i>	<i>Description</i>	<i>Ref.</i>	<i>Part Number</i>	<i>Qty.</i>	<i>Description</i>
1	121-7988-01	2	Fork-Caster	4	116-5647	2	Seal-Grease
2	140-5485	2	Mf Wheel Tire Bearing ASM	5	1-633508	6	Washer-Bellville
2:2	103-2768	2	Guard-Seal	6	3296-51	2	Nut-Lock, NI
2:3	3296-45	1	Nut-Hex	7	145-3415	2	Cap, Grease
2:4	325-20	1	Screw-HH	8	1-811010	2	Plug
3	1-543509	4	Bearing-Roller, Tapered				

Wheel and Bearing Assembly

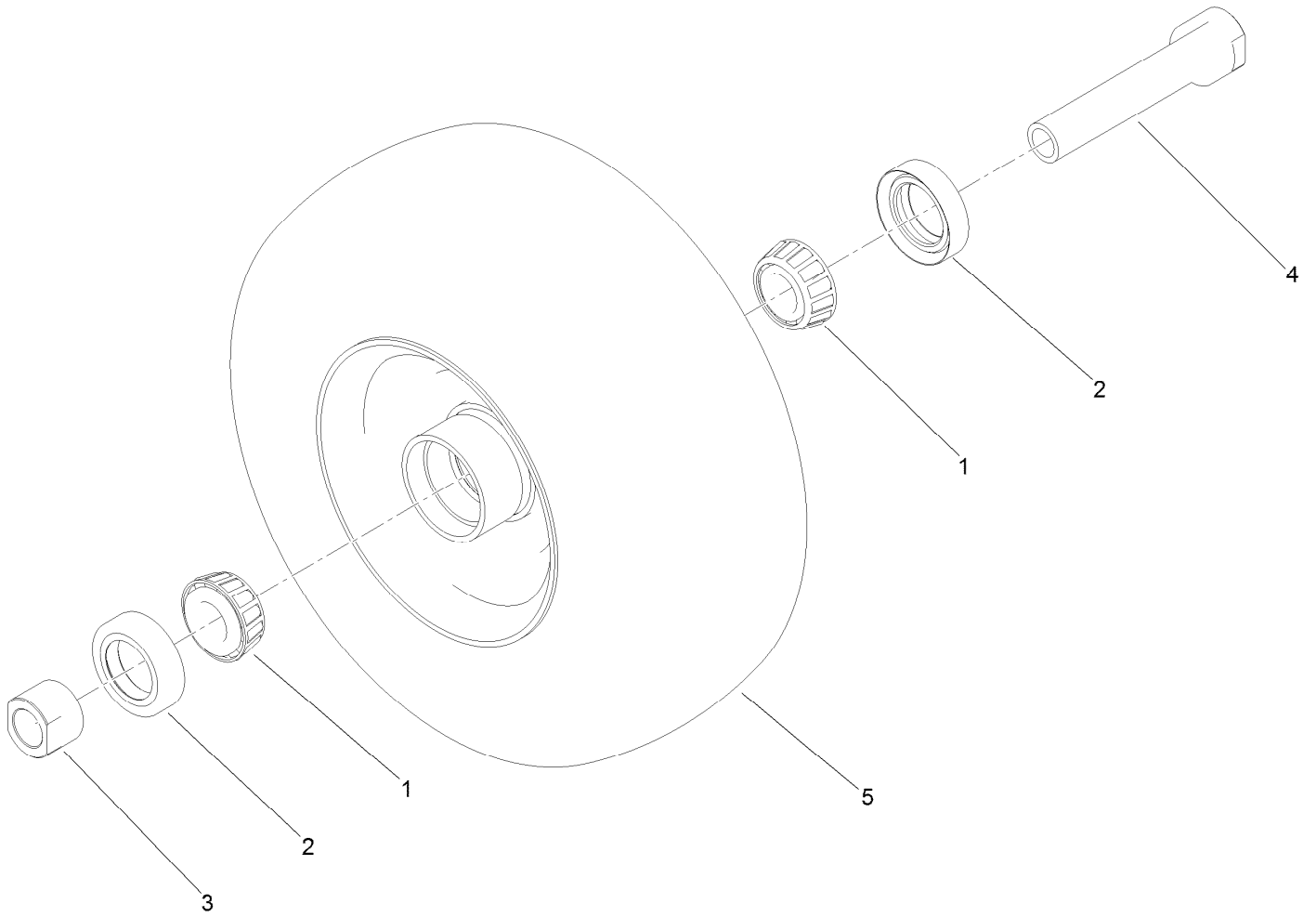

Wheel and Bearing Assembly (continued)

<i>Ref.</i>	<i>Part Number</i>	<i>Qty.</i>	<i>Description</i>	<i>Ref.</i>	<i>Part Number</i>	<i>Qty.</i>	<i>Description</i>
1	1-633585	2	Bearing-Cone, Taper	4	126-5359	1	Caster Axle ASM
2	103-0063	2	Seal-Caster	5	140-5483	1	Mf Wheel And Tire ASM
3	103-3051	1	Spacer-Nut				

Battery Assembly

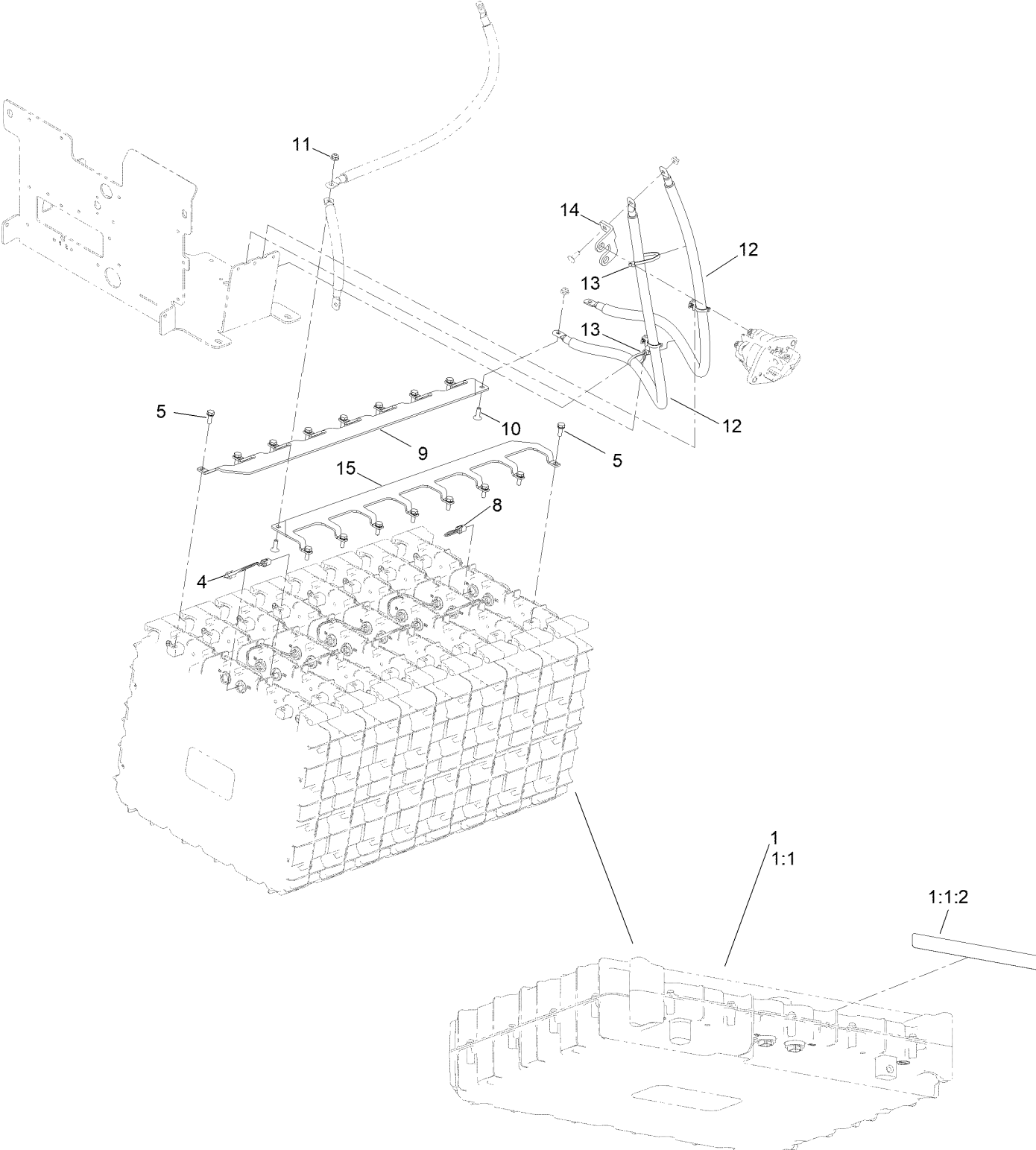

Battery Assembly (continued)

<i>Ref.</i>	<i>Part Number</i>	<i>Qty.</i>	<i>Description</i>	<i>Ref.</i>	<i>Part Number</i>	<i>Qty.</i>	<i>Description</i>
1	145-5320	8	Battery ASM	10	1-807512	3	Bolt-CARR
1:1		1	Battery ASM ■	11	104-7201	3	Nut-HF, NI
1:1:2	144-0276	1	Decal-Warning, Battery	12	147-0273	2	Cable-Battery,Rd ASM
4	140-9565	7	Harness-Wire, Data Interface	13	3290-378	2	Tie-Cable
5	145-5783	16	Screw-Sems	14	147-0370	1	Busbar-2, Switch
8	122-2323	1	Harness-Wire, Can Terminator	15	147-0341	1	Busbar-8, Bk
9	147-0234	1	Busbar-8, Rd	99	144-3848	1	Charger-Single, 120V ●
				99:1	137-7983	1	Cord-AC, 120V ●
				99:2	147-0227	1	Cable, DC-Hypercell ●

● Not illustrated

■ Not serviced separately

Electrical Assembly

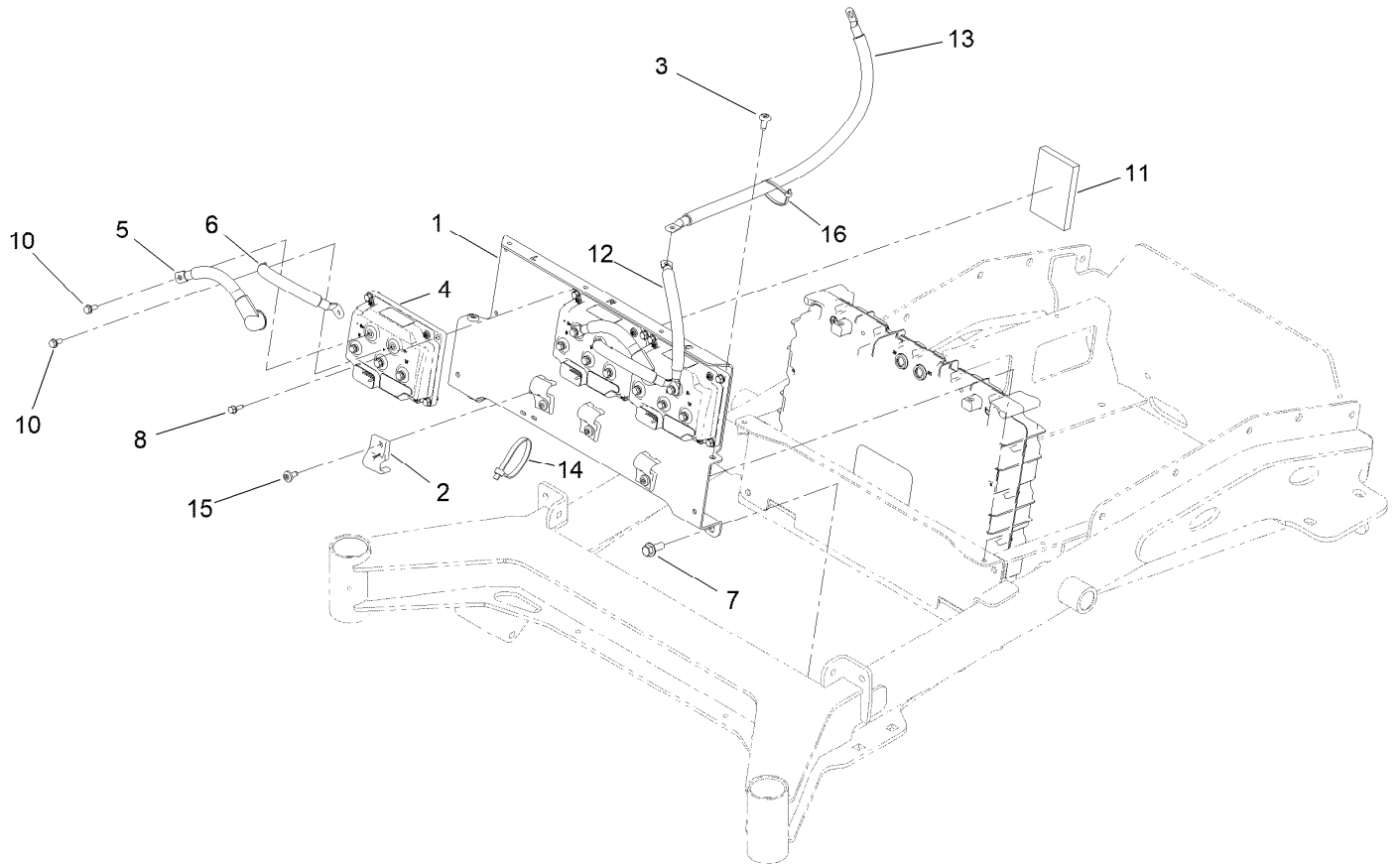

Electrical Assembly (continued)

<i>Ref.</i>	<i>Part Number</i>	<i>Qty.</i>	<i>Description</i>	<i>Ref.</i>	<i>Part Number</i>	<i>Qty.</i>	<i>Description</i>
1	144-6956-03	1	Plate-Motor Controller Mnt	10	145-5782	15	Screw-Sems
2	145-6985	4	Mount-Cable	11	100-2196	1	Pad-Foam
3	138-9753	2	Screw	12	147-0241	1	Cable-Battery, Bk ASM
4	145-7270	3	Inv/Ctrlr-48V	13	147-0242	1	Cable-Battery, Bk ASM
5	147-0238	2	Cable-Battery, Rd ASM	14	3334-945	1	Tie-Cable
6	147-0239	2	Cable-Battery, Bk ASM	15	120-7950	4	Screw-Torx
7	3234-42	2	Screw-HHF	16	3290-379	1	Tie-Cable
8	32144-44	12	Screw-HWH, Thread Roll				

Battery Cable Assembly

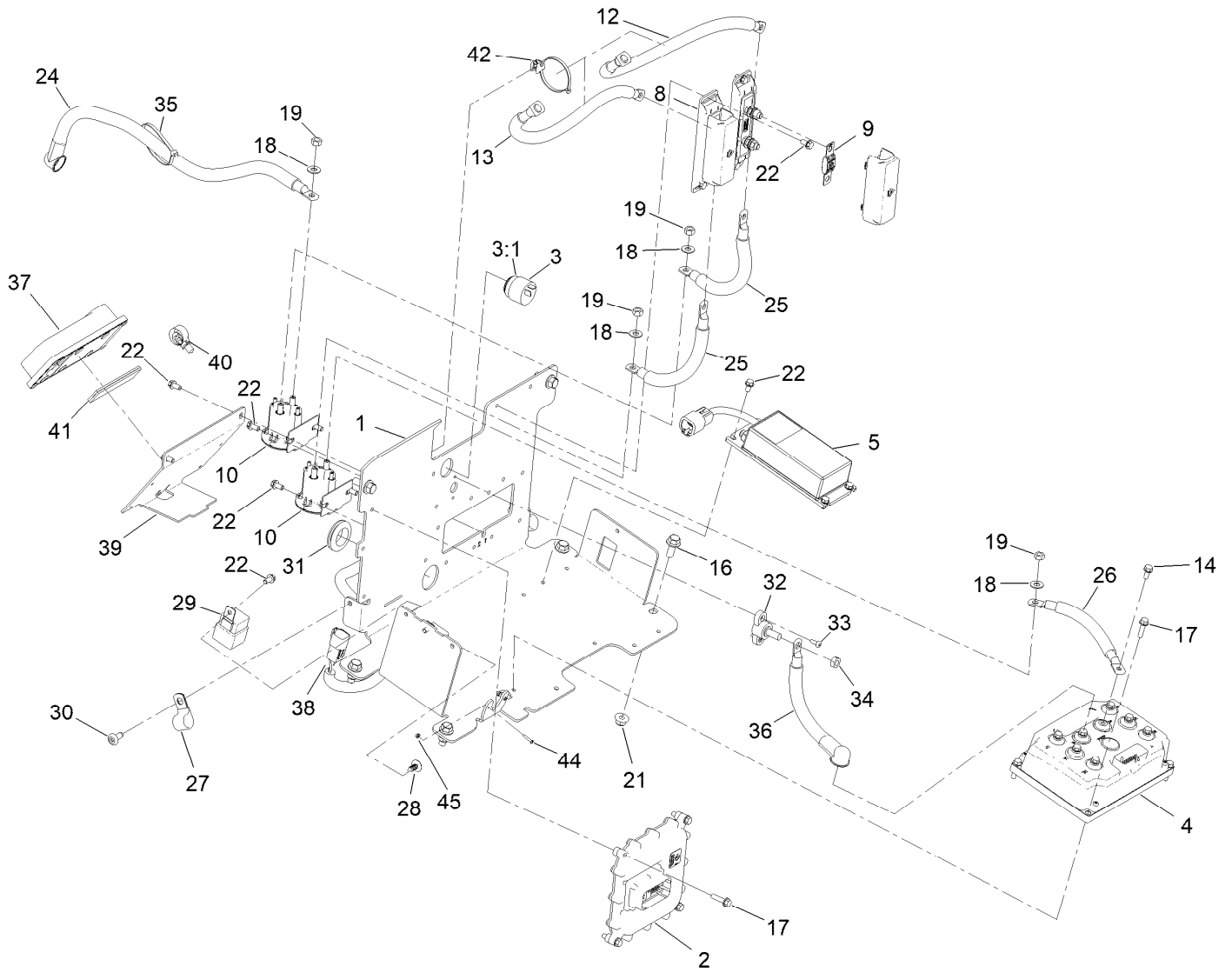

Battery Cable Assembly (continued)

<i>Ref.</i>	<i>Part Number</i>	<i>Qty.</i>	<i>Description</i>	<i>Ref.</i>	<i>Part Number</i>	<i>Qty.</i>	<i>Description</i>
1	145-3563-03	1	Plate-Mnt, Electrical	26	147-0237	1	Cable-Battery, Rd ASM
2	127-2770	1	Controller	27	2412-4	2	Clamp-R
3	80-9330	1	Audio Alarm ASM	28	117-2382	1	Plug-Plastic
3:1	104-5107	1	Nut-Plastic, Knurled	29	70-1480	2	Relay
4	138-8984	1	Inv/Ctrlr-48V,Dual 94Arms	30	138-9753	2	Screw
5	144-6975	1	Converter DC-DC	31	120-3265	1	Grommet
8	145-4958	2	Holder-Fuse	32	110-8823	1	Block-Junction
9	122-2561	2	Fuse-200A	33	105-6849	2	Screw-Forming, Thread
10	145-3542	2	Contacto-DC, 12V	34	3217-7	1	Nut-Hex
12	147-0332	1	Cable-Battery, Rd ASM	35	3290-379	1	Tie-Cable
13	147-0331	1	Cable-Battery, Rd ASM	36	147-0240	1	Cable-Battery, Bk ASM
14	145-5782	8	Screw-Sems	37	139-8189	1	Controller
16	3234-42	6	Screw-HHF	38	147-0250	1	Harness-Wire
17	32144-86	8	Screw-HWHTF	39	145-3578-03	1	Plate-Mount, Calamp
18	107-0279	4	Washer	40	32180-030	1	Clip-Tie
19	3219-2	4	Nut-Hex	41	147-0220	1	Strip-Fastener, Adhesive
21	104-8301	4	Nut-HF, NI	42	32180-150	1	Clip-Harness. Edge, W/Tie-Wrap
22	32144-4	16	Screw-HWH	44	1-3084	2	Screw-PPH
24	147-0228	1	Cable-Battery, Rd ASM	45	9157324	2	Nut-Hex, NYL INS
25	147-0225	2	Cable-Battery, Rd ASM				

Control Panel and Harness Assembly

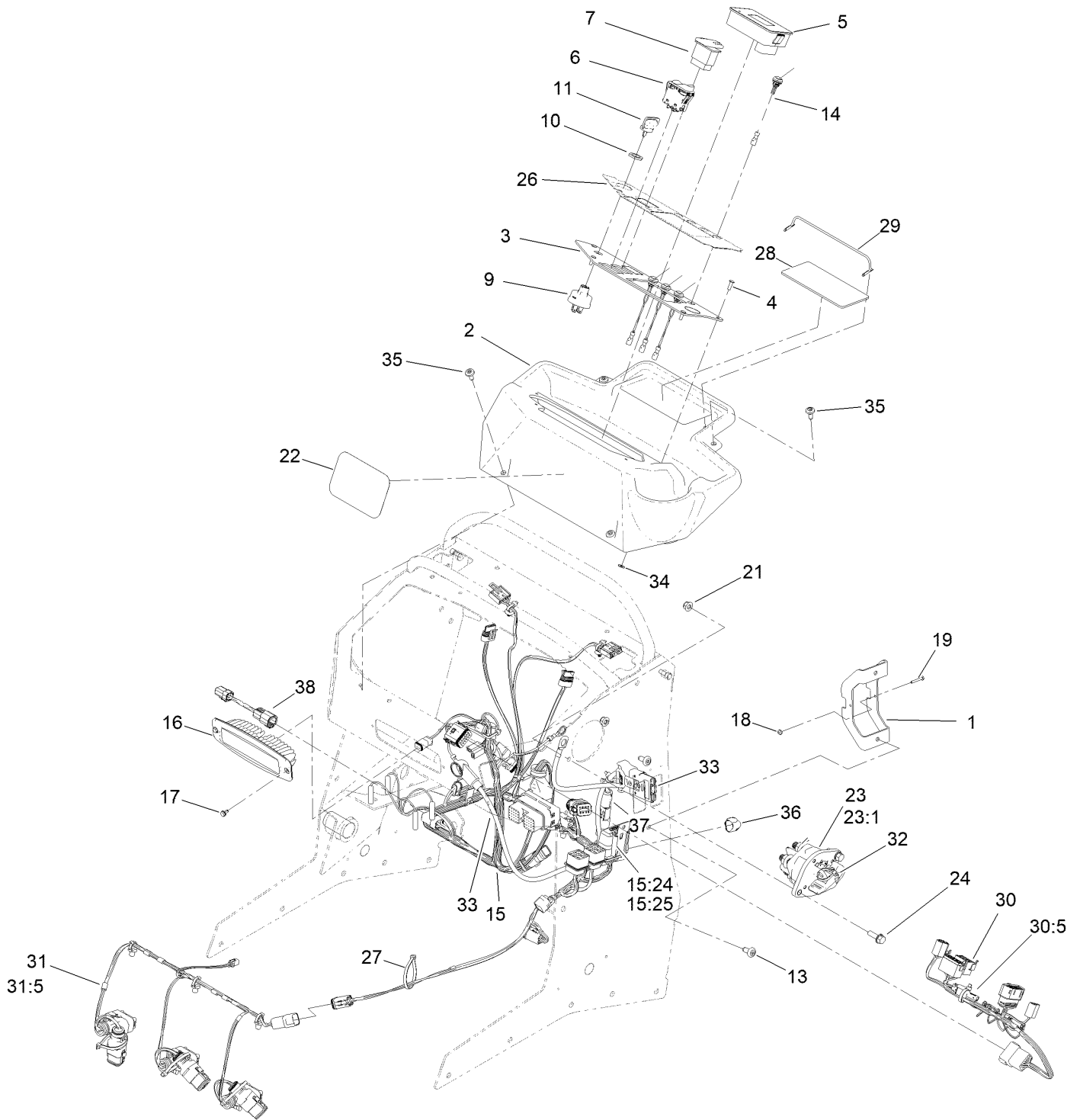

Control Panel and Harness Assembly (continued)

<i>Ref.</i>	<i>Part Number</i>	<i>Qty.</i>	<i>Description</i>	<i>Ref.</i>	<i>Part Number</i>	<i>Qty.</i>	<i>Description</i>
1	145-3597-03	1	Bracket-Charger, Dual	22	94-2579	1	Decal
2	144-1576	1	Dash-Control Panel	23	122-0603	1	Switch-Disconnect
3	147-1685-03	1	Plate-Control Panel	23:1	33006-00	1	Nut-HF
4	3269-4	4	Rivet-Pop	24	3234-29	2	Screw-HHF
5	122-1201	1	Module-Display	26	147-1686	1	Decal-Panel, Control
6	139-6367	1	Switch-Rocker, (On)-On-Off	27	3290-379	1	Tie-Cable
7	95-8999	1	Switch-Rocker, On-None-On	28	145-3410	1	Pad-Rubber, W/Adhesive
9	139-7716	1	Switch-Key, Spst	29	144-6973	1	Strap-Elastic
10	101884	1	Nut	30	145-3411	1	Harness-Wire, Control Panel
11	63-8360	1	Key-Ignition	30:5	32180-282	1	Resistor-120 Ohm
13	138-9753	2	Screw	31	145-3412	1	Harness-Wire, Deck
14	136-9678	4	Switch-Pushbutton	31:5	32180-282	1	Resistor-120 Ohm
15	140-9567	1	Harness-Wire, Main	32	3290-378	5	Tie-Cable
15:24	121-8861	2	Fuse-Mini Blade, 2 Amp	33	140-9596	1	Harness-Wire, Charger Port
15:25	121-8864	3	Fuse-Mini Blade, 5 Amp ●	34	3269-26	4	Washer-Plain
16	139-8089	1	Mount-Flush, Light	35	120-7950	4	Screw-Torx
17	104-2065	2	Screw-HWH	36	32180-089	1	Cap-Plug, 3 Way
18	3296-9	1	Nut-Hex	37	112-1540	1	Ferrite-Snap On
19	32105-9	1	Screw-HH	38	161-3544	1	Harness-Wire, Jumper
21	104-8300	2	Nut-HF, NI				

● Not illustrated

Attachments and Accessories

For 18560 GrandStand Revolution Mower With 52in TURBO FORCE Cutting Unit

Product Name	Model/Part
Turbo Baffle Kit	107-1634
HOC Set Blocks	133-1439
Anti-Scalp Kit, 48/52 Grandstand Deck	133-1440
Blade-18.0in, Med Sail	145-3504-03
Blade-18.0in, Recycler	145-3507-03
Kit, Stand-On Weight	147-0200
Recycler Kit	147-0310
Wiring Harness Adapter Kit	147-1612
Soft Bag (3 Bushel)	30104

Notes:



Count on it.