



Count on it.

Parts Catalog

60in TITAN® MAX

Riding Mower

Model No. 76601—Serial No. 412173589 and Up



Ordering Replacement Parts

To order replacement parts, please supply the part number, the quantity, and the description of each part desired.

Understanding Reference Numbers

Each identified part in an illustration has a reference number. The reference number for a part also appears in the parts list, along with other information about the part.

This catalog uses two special reference number formats, one to indicate parts in a service assembly and another to indicate the quantity of a given part in an illustration.

Service Assembly Reference Numbers

Parts in service assemblies have reference numbers in the form a:b. The a represents the reference number of the entire service assembly and the b represents a sequential number unique to each part within the service assembly.

For example, a wheel assembly might be identified by reference number 6, the tire by 6:1, the valve by 6:2, and the wheel by 6:3. When you order the assembly identified by reference number 6, you receive all parts identified by reference numbers 6:1, 6:2, and 6:3. However, you may also order any part individually. Reference numbers of this type appear in illustration and in parts lists.

Reference Numbers Indicating Quantity

In an illustration, if a reference number indicates more than one part, the reference number has the form nX y. The n represents the quantity of the part, the X is the multiplication symbol, and the y represents the reference number.

For example, in an illustration, the reference number 2X 37 means that two of the parts identified by reference number 37 are indicated.

Contents

Frame Assembly	4
Roll-Over Protection System Assembly No. 144-1848	6
Transaxle Assembly	8
LH Transaxle Assembly No. 135-0140	10
RH Transaxle Assembly No. 135-0139	12
Console and Guard Assembly	14
Fuel Tank and Vent Hose System Assembly	16
Fuel Tank Assembly No. 126-4724	18
Seat Pan Assembly	20
Seat Assembly No. 144-1965	22
Motion Control Assembly	24
LH and RH Motion Control Assembly	26
Front Caster Wheel Assembly	28
Caster Wheel and Fork Assembly	30
Wheel Assembly	32
Electrical Assembly	34
Harness Assembly No. 126-5803	36
Deck Lift Assembly	38
Deck Strut Assembly No. 126-8365	40
Engine Assembly	42
60in Deck Assembly	44
60in Deck Decal Assembly No. 144-1895	46
Attachments and Accessories	48

Frame Assembly

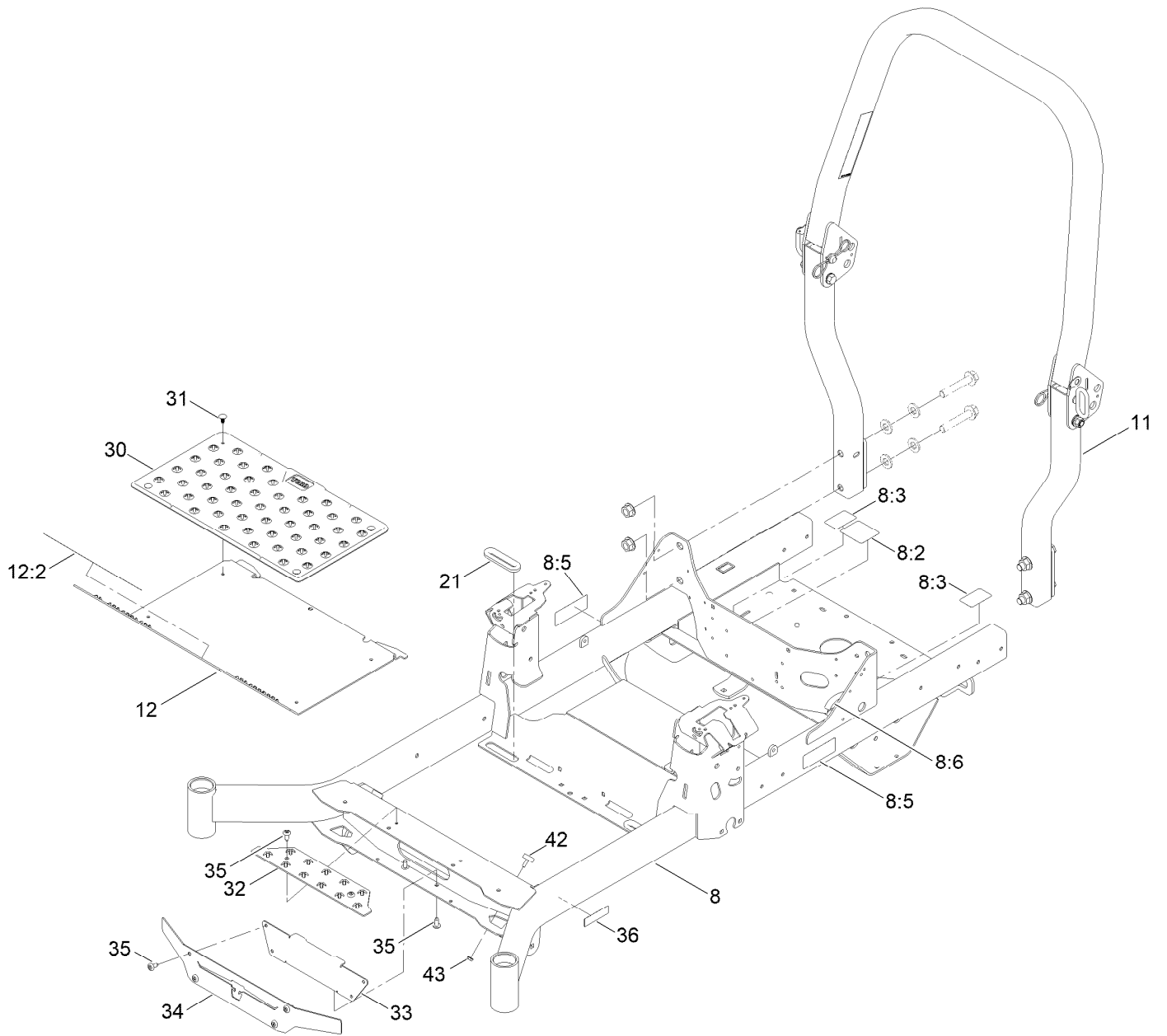

Frame Assembly (continued)

<i>Ref.</i>	<i>Part Number</i>	<i>Qty.</i>	<i>Description</i>	<i>Ref.</i>	<i>Part Number</i>	<i>Qty.</i>	<i>Description</i>
8	144-1838	1	Frame-60	30	144-1961	1	Mat-Floor
8:2	109-6014	1	Decal-Routing, Belt	31	117-2382	4	Plug-Plastic
8:3	116-8588	2	Decal-Release, Drive	32	144-1883-03	1	Plate-Step
8:5	126-4363	2	Decal-Warning	33	144-1884-01	1	Plate-Backer
8:6	127-6618	1	Strip-Seal	34	144-1885-03	1	Plate-Fascia
11	144-1848	1	ASM-ROPS	35	138-9753	8	Screw
12	144-1958	1	Pan-Floor ASM	36	140-2099	1	Decal
12:2	126-8383	1	Decal-Danger	42	138-2662	2	Bumper-Rubber
21	126-7065	2	Grommet-Rubber	43	32128-33	2	Nut-HF

Roll-Over Protection System Assembly No. 144-1848

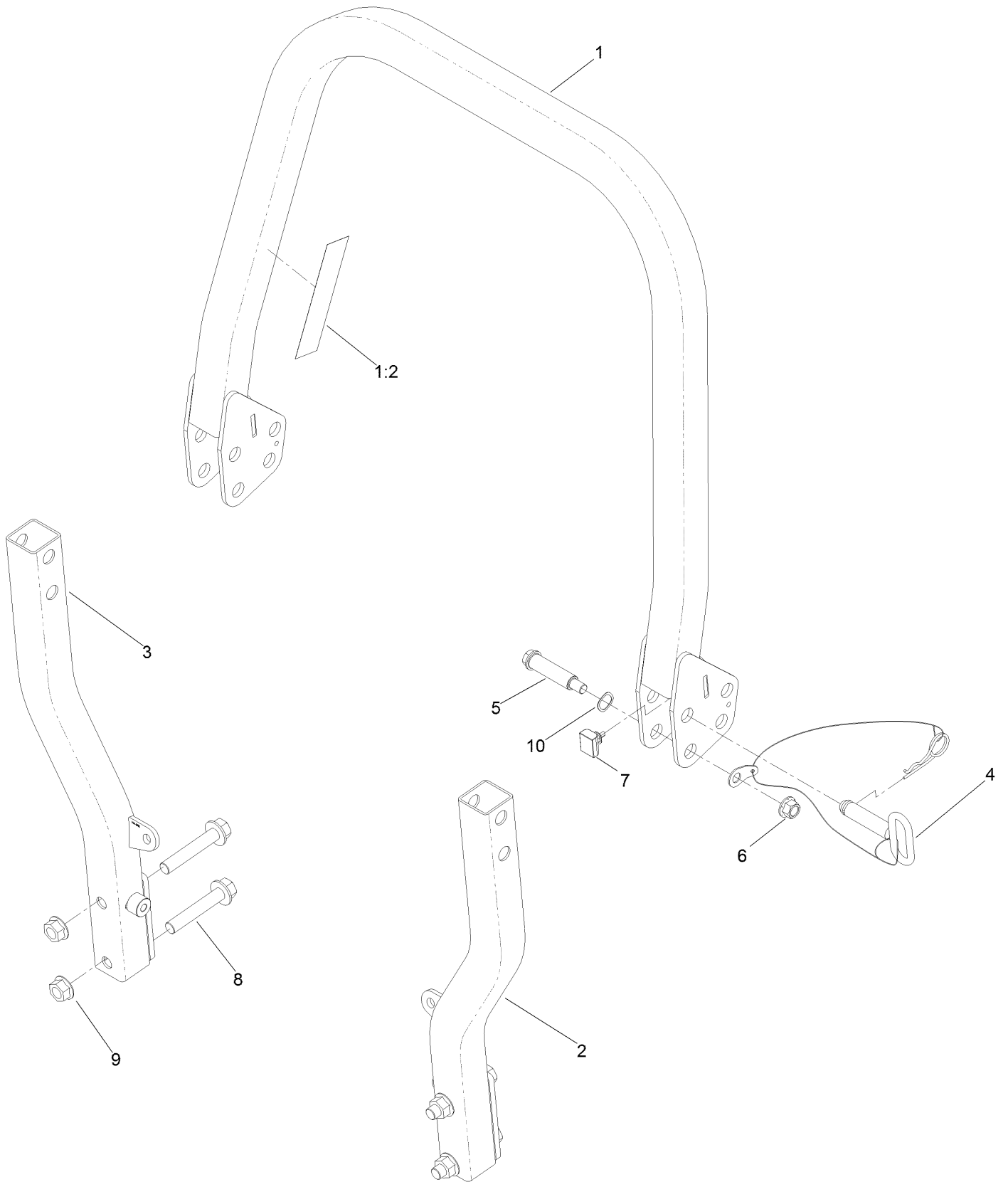

Roll-Over Protection System Assembly No. 144-1848 (continued)

<i>Ref.</i>	<i>Part Number</i>	<i>Qty.</i>	<i>Description</i>	<i>Ref.</i>	<i>Part Number</i>	<i>Qty.</i>	<i>Description</i>
1		1	Upper ROPS ASM ●	6	99-5107	2	Nut-Lock
1:2	107-3069	1	Decal-Warning	7	109-5337	2	Bumper-ROPS
2		1	LH Lower ROPS ASM ●	8	126-9488	4	Screw-HHF
3		1	RH Lower ROPS ASM ●	9	32128-50	4	Nut-Flange
4	103-4553	2	ROPS Fold Pin ASM	10	119-4164	2	Washer-Wave
5	126-9209	2	Bolt-Shoulder				

● Not serviced separately

Transaxle Assembly

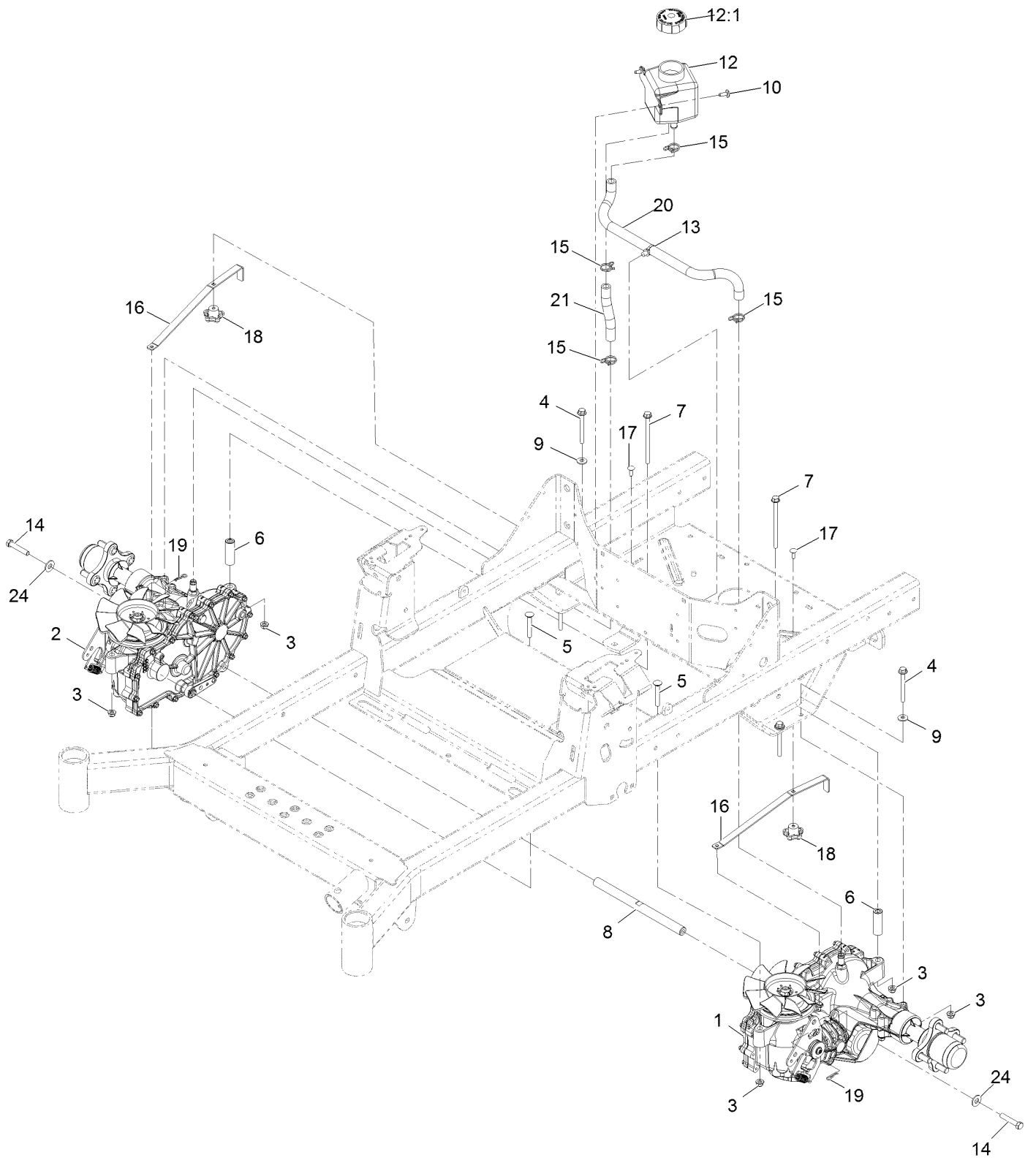

Transaxle Assembly (continued)

<i>Ref.</i>	<i>Part Number</i>	<i>Qty.</i>	<i>Description</i>	<i>Ref.</i>	<i>Part Number</i>	<i>Qty.</i>	<i>Description</i>
1	135-0140	1	LH Transaxle ASM	12	109-2250	1	Tank-HYD
2	135-0139	1	RH Transaxle ASM	12:1	109-3320	1	Cap-Reservoir, HYD
3	104-8300	8	Nut-Nyloc 5/16-18 Flg	13	32180-118	1	Clip-Tie
4	126-4687	4	Screw-HHF	14	94-7972	2	Screw-HH W/Loctite ●
5	3230-7	2	Bolt-Carriage 5/16-18 X 2 1/4	15	126-0327	4	Clamp-Hose
6	116-5809	2	Spacer-Hydro	16	109-5395	2	Arm-Bypass, Hydro
7	126-5896	2	Screw HHF	17	3229-1	2	Bolt-Carriage 1/4-20 X 3/4
8	116-6833	1	Shaft-Spacer	18	108-6402	2	Knob-Handle
9	1-303334	4	Washer-Spring Disc 5/16	19	1-806003	2	Hairpin-Cotter
10	126-6266	2	Screw-1/4-20 X .65 Torx Plus	20	126-5668	1	Hose-Hydraulic
				21	126-5669	1	Hose-Hydraulic
				24	3256-4	2	Washer-3/8 Std

● Use Pro-Lock, Nut Type (P/N 1-840022, .5ml tube) on threads.

LH Transaxle Assembly No. 135-0140

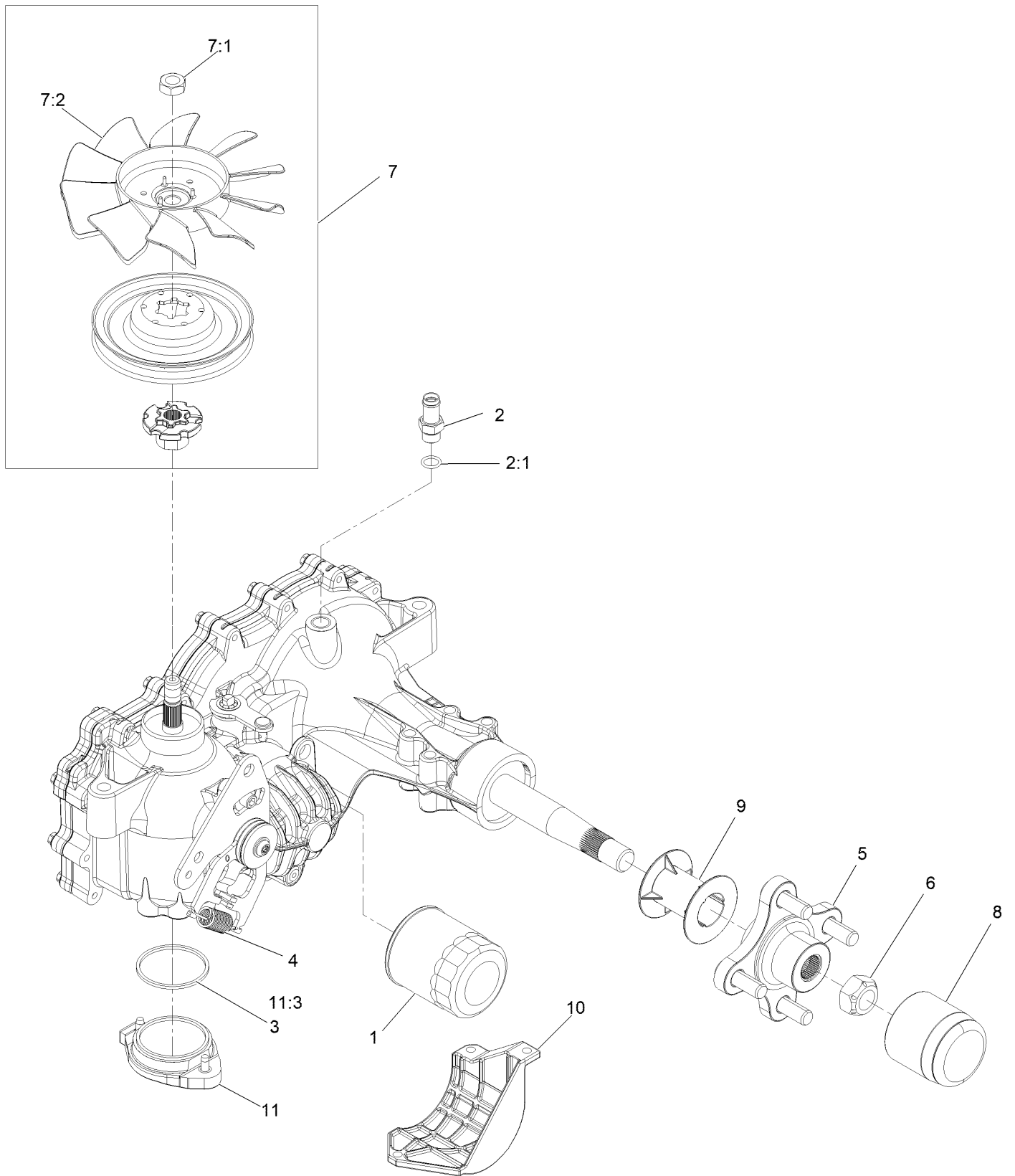

LH Transaxle Assembly No. 135-0140 (continued)

<i>Ref.</i>	<i>Part Number</i>	<i>Qty.</i>	<i>Description</i>	<i>Ref.</i>	<i>Part Number</i>	<i>Qty.</i>	<i>Description</i>
1	109-3321	1	Element-Oil Filter, HYD	7:2	126-0226	1	Fan
2	109-3278	1	Adapter-Straight	8	116-6214	1	Cap-Axle, Long
2:1	237-42	1	O-Ring	9	116-6213	1	Tube-Axle
3	109-3540	1	O Ring-Seal	10	120-7979	1	Guard-Filter, LH
4	109-5592	1	Spring-Extension	11	114-8465	1	Charge Kit
5	116-3872	1	Hub-Offset	11:3	109-3540	1	O Ring-Seal
6	109-3536	1	Nut-Hub	99	135-3604	1	Brake Shaft Seal Kit
7	135-7347	1	Fan And Pulley Kit	99	109-3537	1	Seal Kit ●
7:1	116-9714	1	Nut-HJ				

● Not illustrated

RH Transaxle Assembly No. 135-0139

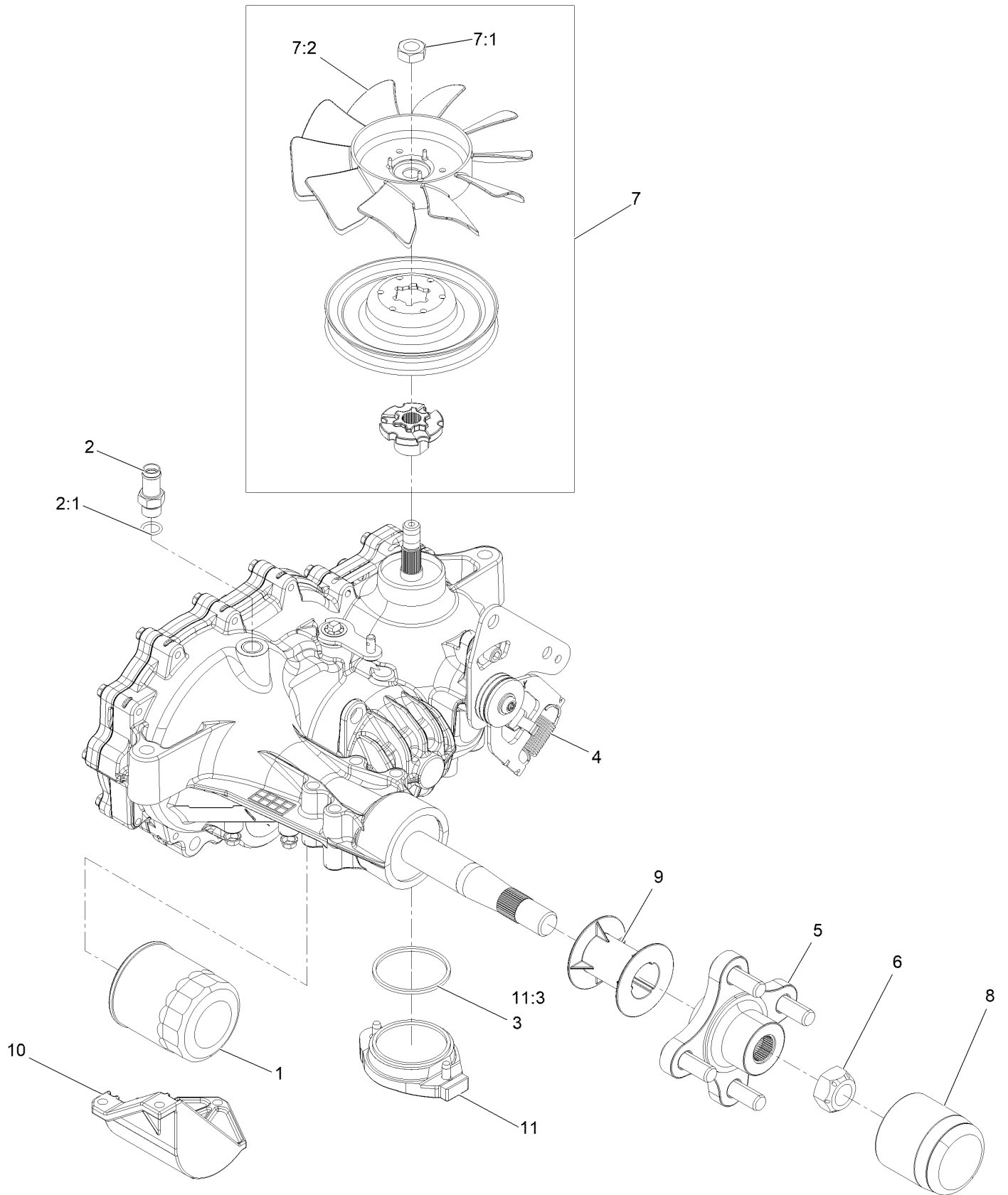

RH Transaxle Assembly No. 135-0139 (continued)

<i>Ref.</i>	<i>Part Number</i>	<i>Qty.</i>	<i>Description</i>	<i>Ref.</i>	<i>Part Number</i>	<i>Qty.</i>	<i>Description</i>
1	109-3321	1	Element-Oil Filter, HYD	7:2	126-0226	1	Fan
2	109-3278	1	Adapter-Straight	8	116-6214	1	Cap-Axle, Long
2:1	237-42	1	O-Ring	9	116-6213	1	Tube-Axle
3	109-3540	1	O Ring-Seal	10	120-7981	1	Guard-Filter, RH
4	109-5592	1	Spring-Extension	11	114-8465	1	Charge Kit
5	116-3872	1	Hub-Offset	11:3	109-3540	1	O Ring-Seal
6	109-3536	1	Nut-Hub	99	135-3604	1	Brake Shaft Seal Kit
7	135-7347	1	Fan And Pulley Kit	99	109-3537	1	Seal Kit ●
7:1	116-9714	1	Nut-HJ				

● Not illustrated

Console and Guard Assembly

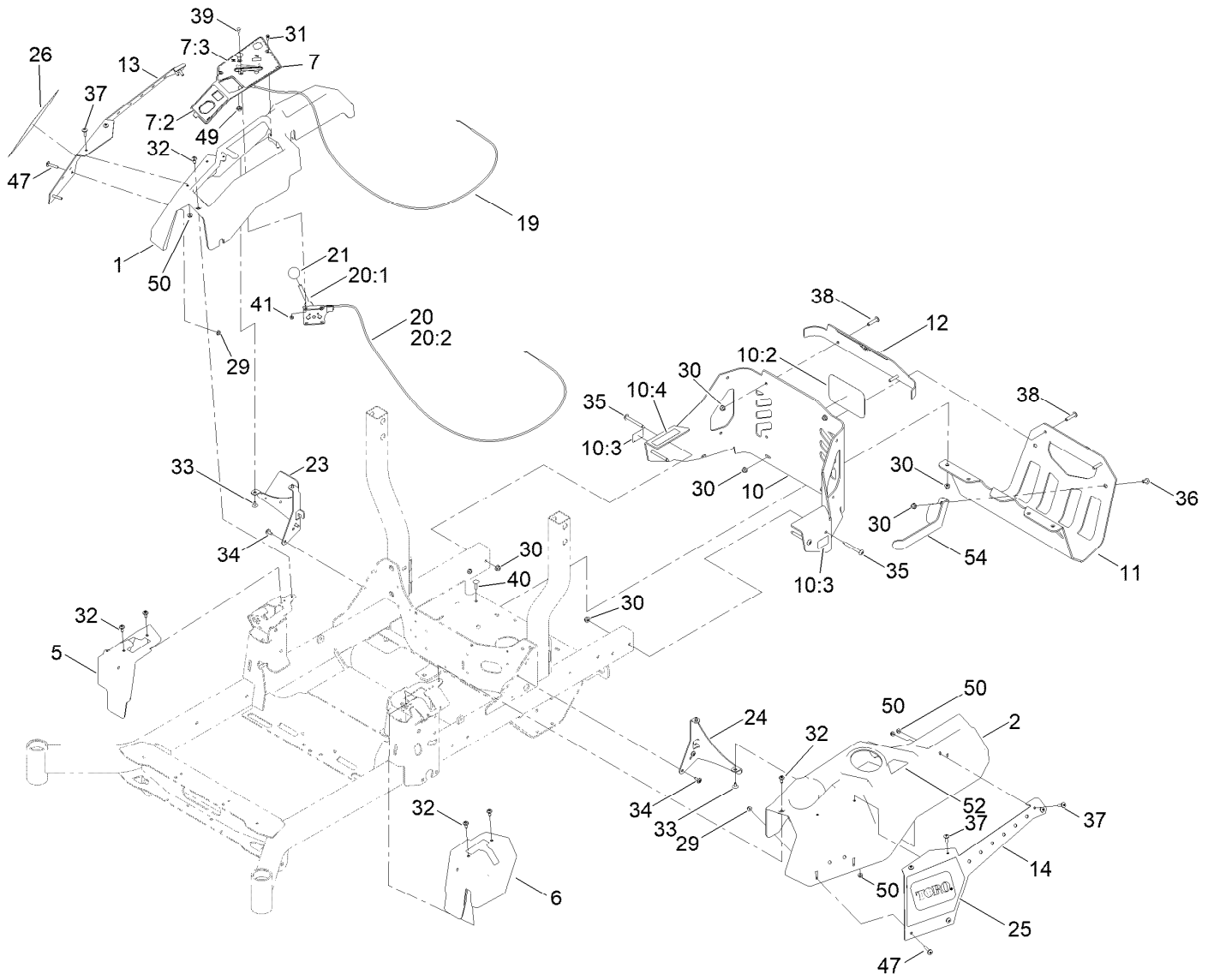

Console and Guard Assembly (continued)

<i>Ref.</i>	<i>Part Number</i>	<i>Qty.</i>	<i>Description</i>	<i>Ref.</i>	<i>Part Number</i>	<i>Qty.</i>	<i>Description</i>
1	126-4983	1	Console-RH	24	126-5532-03	1	Bracket-Console, LH
2	126-4984	1	Console-LH	25	144-1967	1	Decal-Plate, LH
5	126-7371	1	Cover-Control, Motion (RH)	26	144-1966	1	Decal-Plate, RH
6	126-7372	1	Cover-Control, Motion (LH)	29	104-7201	4	Nut-HF, NI
7	147-0323	1	Control Panel ASM	30	104-8300	11	Nut-HF, NI
7:2	126-9115	1	Decal-Panel, Control	31	117-5036	2	Screw-Plastic, HWH
7:3	137-9240	1	Decal-Panel, Control	32	120-7950	6	Screw-Torx
10	139-3643	1	Rear Guard ASM	33	126-5544	4	Screw-Torx
10:2	99-4693	1	Decal	34	126-6266	4	Screw-Tph
10:3	106-5517	2	Decal-Warning	35	126-6267	4	Screw-TTH
10:4	133-8062	1	Decal-Spark Arrestor	36	126-6268	1	Screw-TTH
11	135-5084-03	1	Guard-Muffler [black]	37	126-6269	8	Screw-Truss
12	139-3644-01	1	Trim-Upper Rear	38	126-7439	4	Screw-Torx
13	136-1745-01	1	Cover-Pod, RH	39	1-807513	2	Bolt-CARR
14	136-1746-01	1	Cover-LH	40	3230-22	2	Screw-CARR
19	144-2647	1	Cable-Choke Control	41	3296-2	2	Nut-Lock, NI
20	110-5727	1	Throttle Control ASM	47	126-8232	4	Screw-Truss Hex Skt
20:1	112-2334	1	Lever-Throttle	49	3220-3	1	Nut-HJ
20:2	110-5728	1	Cable-Throttle	50	32149-2	8	Nut-Keps
21	1-603175	1	Knob-Ball	52	126-9939	1	Decal-Fill, Fuel
23	126-9945	1	Support-Console, RH	54	144-1971-03	1	Bracket-Guard, Muffler

Fuel Tank and Vent Hose System Assembly (continued)

<i>Ref.</i>	<i>Part Number</i>	<i>Qty.</i>	<i>Description</i>	<i>Ref.</i>	<i>Part Number</i>	<i>Qty.</i>	<i>Description</i>
2	144-5320	1	Hose-Vent	6:4	2412-98	4	Clamp-Hose
6	144-5322	1	Fuel Hose ASM	8	135-4801	1	Cap-Fuel, Ratcheting
6:1	109-0306	1	Hose-Fuel	9	126-4724	1	Tank-Fuel
6:2	110-5702	1	Hose-Fuel	10	126-5523	5	Clip
6:3	1-603770	1	Valve-Fuel	17	1-303287	1	Tie-Cable

Fuel Tank Assembly No. 126-4724

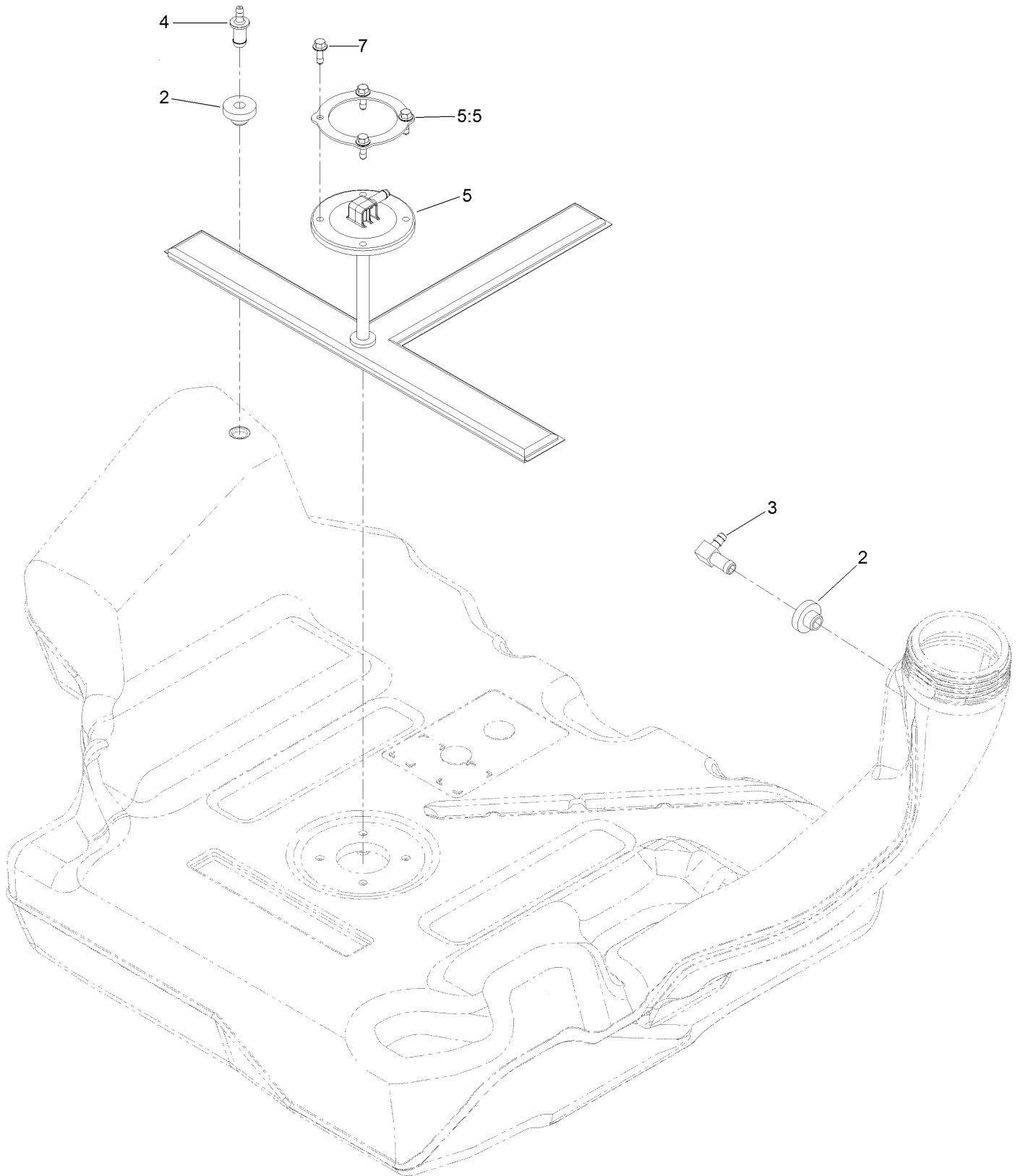

Fuel Tank Assembly No. 126-4724 (continued)

<i>Ref.</i>	<i>Part Number</i>	<i>Qty.</i>	<i>Description</i>	<i>Ref.</i>	<i>Part Number</i>	<i>Qty.</i>	<i>Description</i>
2	46-6560	2	Bushing	5	126-5528	1	Pickup-Fuel
3	126-9057	1	Fitting-90 DEG	5:5	126-5527	1	Ring-Retainer
4	116-4630	1	Fitting-Orifice, Straight	7	126-5525	4	Bolt

Seat Pan Assembly (continued)

<i>Ref.</i>	<i>Part Number</i>	<i>Qty.</i>	<i>Description</i>	<i>Ref.</i>	<i>Part Number</i>	<i>Qty.</i>	<i>Description</i>
2	3230-22	2	Screw-CARR	29	135-7125	2	Washer-Retaining
3	104-8300	6	Nut-HF, NI	31	135-6017-03	1	Plate-Fixed Seat [black]
4	135-0505	2	Bumper-Seat	32	3296-47	1	Nut-Lock,NI
12	144-1965	1	ASM-Seat Toro	35	135-7047	1	Bumper-Rubber
22	144-1947	1	Decal-Titan Max				

Seat Assembly No. 144-1965

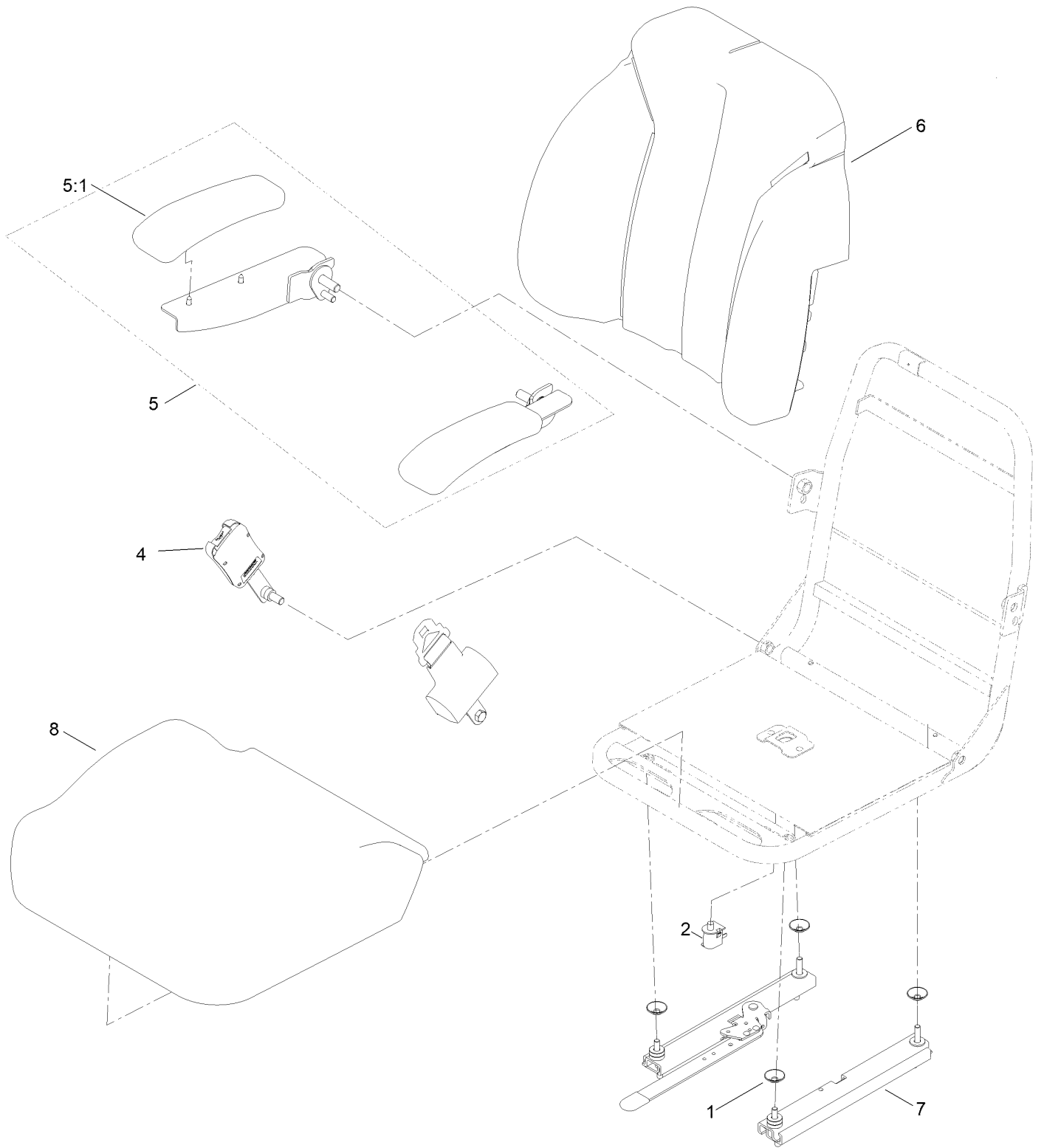

Seat Assembly No. 144-1965 (continued)

<i>Ref.</i>	<i>Part Number</i>	<i>Qty.</i>	<i>Description</i>	<i>Ref.</i>	<i>Part Number</i>	<i>Qty.</i>	<i>Description</i>
1	136-9002	4	Spacer-Mounting	5:1	110-4163	2	Cushion-Rest, Arm
2	82-2190	1	Switch-Bail	6	144-1973	1	Cover-Back, Seat
4	126-9091	1	Seat Belt Kit	7	126-2177	1	Track-Seat
5	126-2058	1	Armrest Kit	8	144-1974	1	Cover-Seat, Bottom

Motion Control Assembly

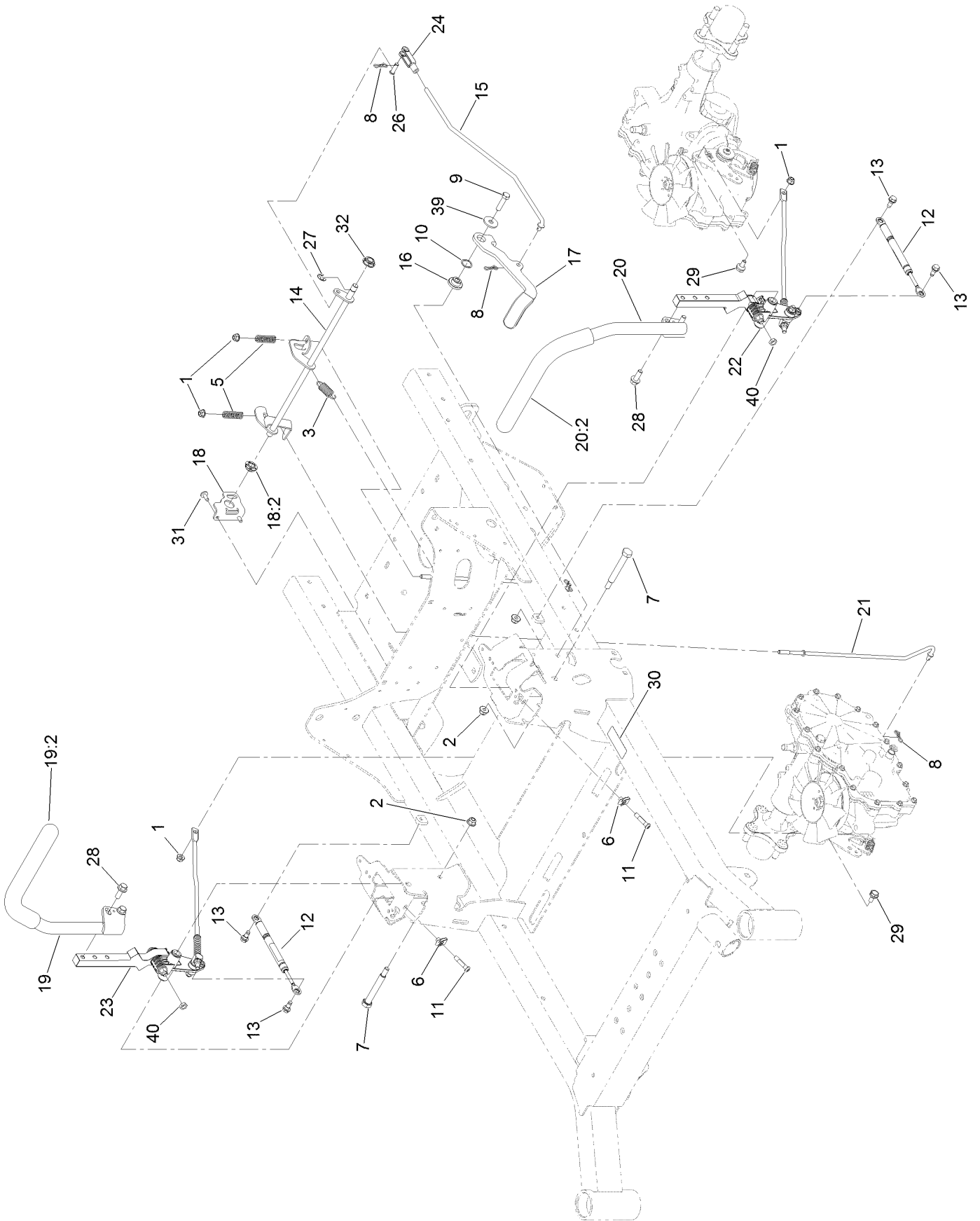

Motion Control Assembly (continued)

<i>Ref.</i>	<i>Part Number</i>	<i>Qty.</i>	<i>Description</i>	<i>Ref.</i>	<i>Part Number</i>	<i>Qty.</i>	<i>Description</i>
1	104-8300	4	Nut-HF, NI	19	126-9191	1	RH Control Handle ASM
2	104-8301	3	Nut-HF, NI	19:2	126-7359	1	Grip
3	107-1045	1	Spring-Extension	20	126-9192	1	LH Control Handle ASM
5	109-7694	2	Spring-Compression	20:2	126-7359	1	Grip
6	112-3306	2	Nut	21	126-7217	2	Linkage-Brake, Lower
7	115-5099	2	Bolt-Pivot	22		1	LH Motion Control ASM ●
8	119-1415	4	Pin-Cotter, Locking	23		1	RH Motion Control ASM ●
9	323-8	1	Screw-HH	24	1-303105	1	Yoke-Adjustable
10	119-4164	1	Washer-Wave	26	1-808280	1	Pin-Clevis
11	126-4299	2	Screw-HSBH	27	32120-47	1	Ring-Retaining, External
12	126-4322	2	Damper	28	3234-42	4	Screw-HHF
13	126-4424	4	Screw-Shoulder	29	37-8771	2	Bolt-Shoulder, HF
14	126-5813	1	Shaft-Brake	30	115-9625	1	Decal-Brake, Parking
15	126-5819	1	Linkage-Brake, Upper	31	126-6266	2	Screw-Tph
16	126-5989	1	Pivot-Flange	32	126-5820	1	Bearing-Spherical
17	126-9490	1	Lever-Brake (With Grip)	39	2844	1	Washer
18	126-6456	1	Bracket-Brake	40	3218-3	2	Nut-Jam
18:2	126-5820	1	Bearing-Spherical				

● Not serviced separately

LH and RH Motion Control Assembly

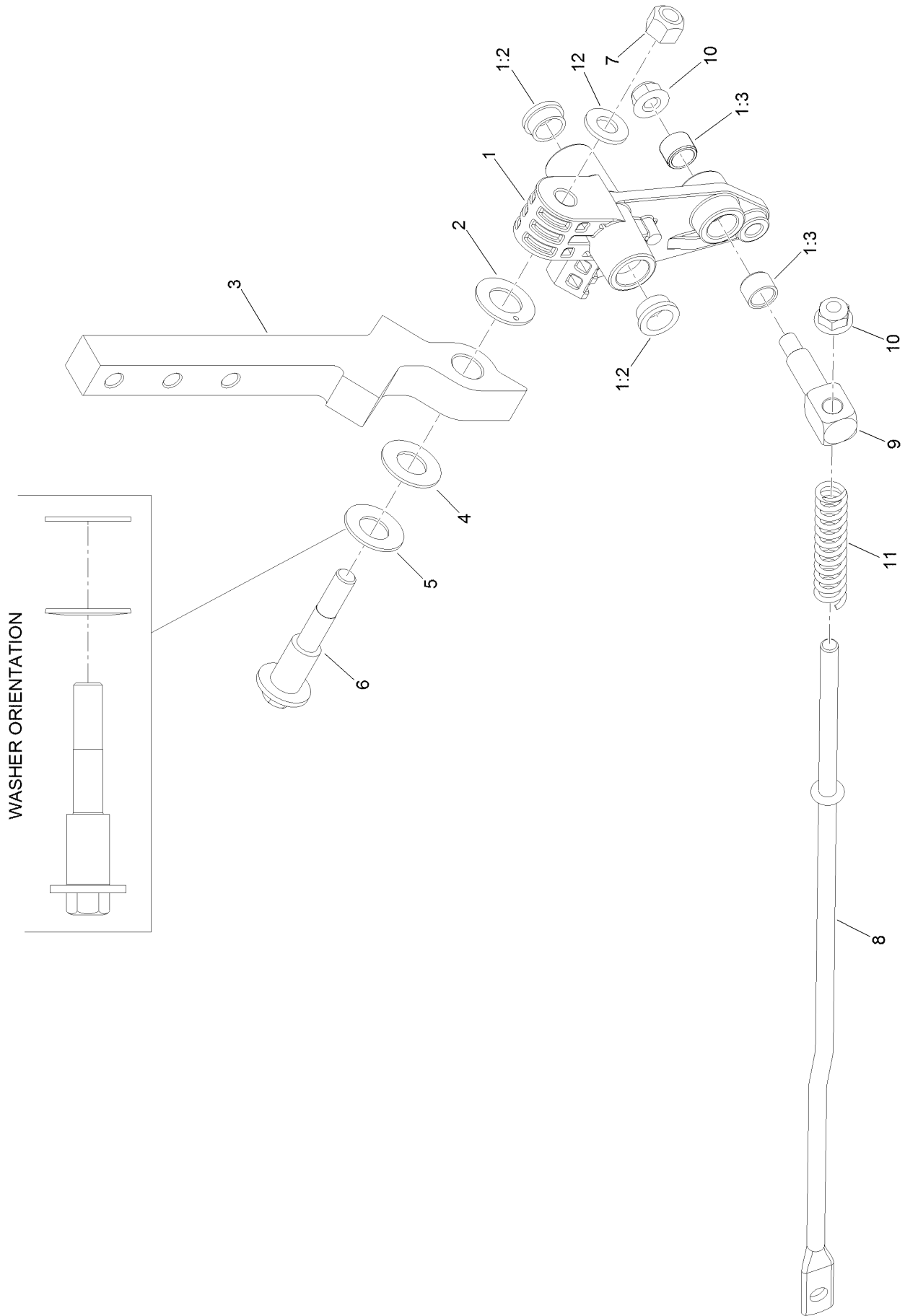

LH and RH Motion Control Assembly (continued)

<i>Ref.</i>	<i>Part Number</i>	<i>Qty.</i>	<i>Description</i>	<i>Ref.</i>	<i>Part Number</i>	<i>Qty.</i>	<i>Description</i>
1	126-3773	1	Control Arm ASM	6	117-1198	1	Bolt-Pivot
1:2	126-8909	2	Bushing	7	32152-2	1	Nut-Lock, Cone
1:3	1-413152	2	Bushing-Sleeve	8	126-5435	1	Link-Control
2	126-7296	1	Washer-Friction	9	126-5434	1	Swivel
3	126-8182	1	Arm-Control	10	104-8300	2	Nut-HF, NI
4	117-1240	1	Washer	11	126-8195	1	Spring-Return, Neutral
5	119-8925	1	Washer-Belleville	12	3256-24	1	Washer-Plain

Font Caster Wheel Assembly

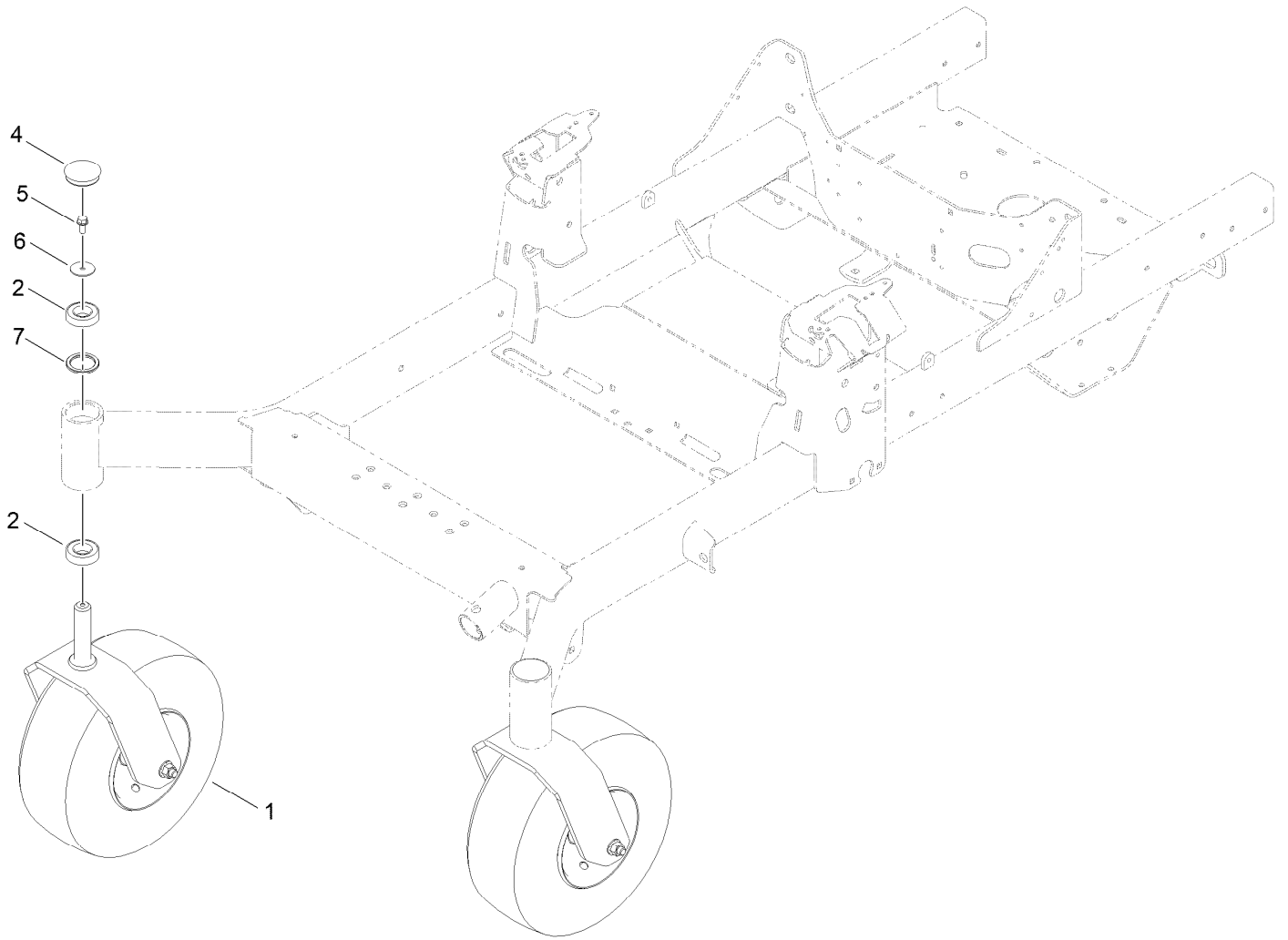

Font Caster Wheel Assembly (continued)

<i>Ref.</i>	<i>Part Number</i>	<i>Qty.</i>	<i>Description</i>	<i>Ref.</i>	<i>Part Number</i>	<i>Qty.</i>	<i>Description</i>
1		2	ASM, Front Caster W/ Fork ●■	5	100-1668	2	Screw-HHF
2	109-3678	4	Bearing-Ball	6	3256-68	2	Washer-Flat
4	144-0375	2	Cap, Grease	7	145-3660	2	Spacer-Bearing

● Not illustrated

■ Not serviced separately

Caster Wheel and Fork Assembly

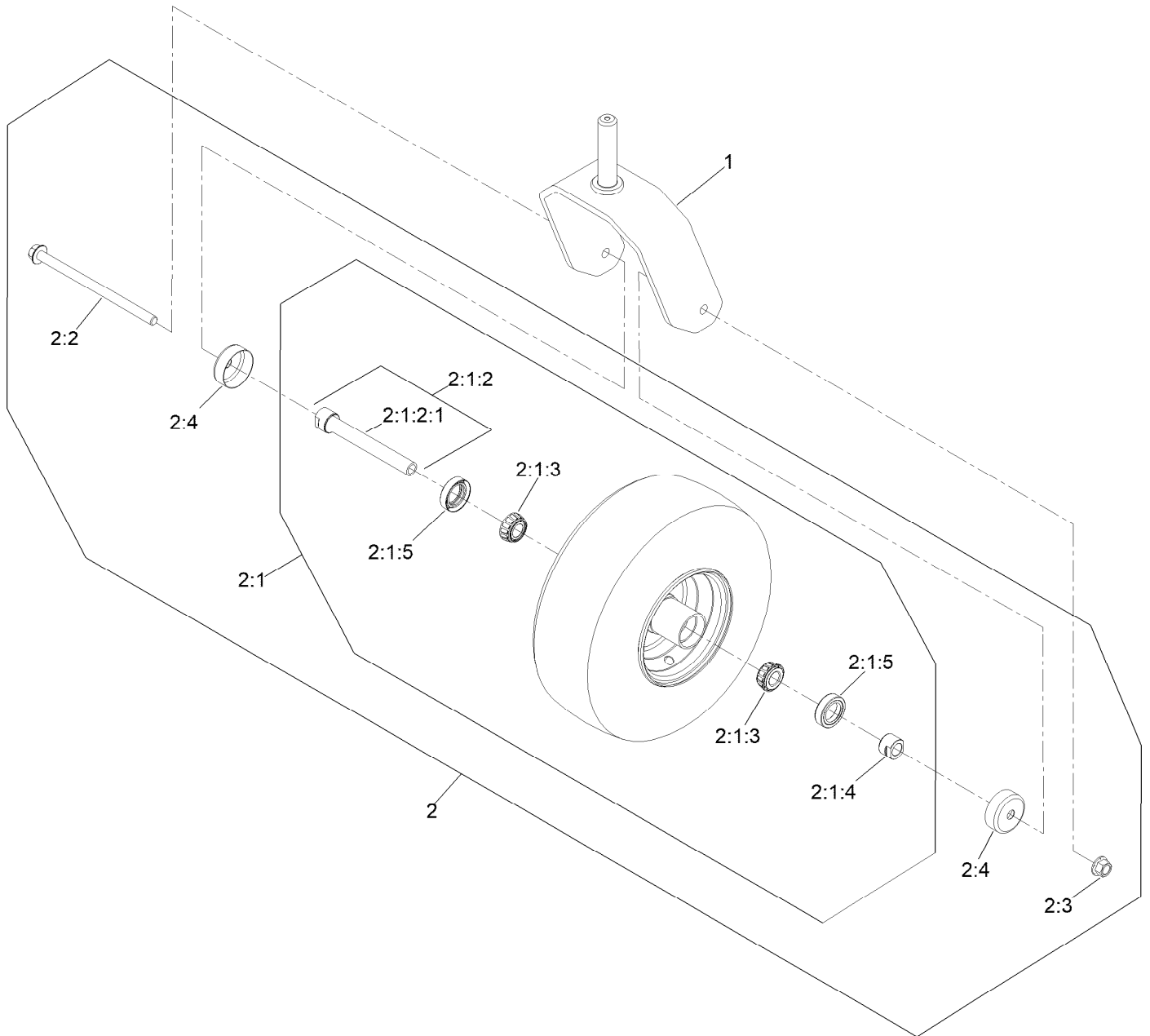

Caster Wheel and Fork Assembly (continued)

<i>Ref.</i>	<i>Part Number</i>	<i>Qty.</i>	<i>Description</i>	<i>Ref.</i>	<i>Part Number</i>	<i>Qty.</i>	<i>Description</i>
1	142-7827-01	1	Fork-Caster	2:1:3	1-633585	2	Bearing-Cone, Taper
2	140-4896	1	Semi Pneumatic ASM	2:1:4	103-3051	1	Spacer-Nut
			13X6.50-6	2:1:5	103-0063	2	Seal-Caster
2:1		1	ASM Whl/Brgs 13X6.50-6 ●	2:2	126-5389	1	Screw-HHF
2:1:2	126-7796	1	Caster Axle ASM	2:3	99-5107	1	Nut-Lock
2:1:2:1	126-5220	1	Axle-Caster	2:4	103-2768	2	Guard-Seal

● Not serviced separately

Wheel Assembly

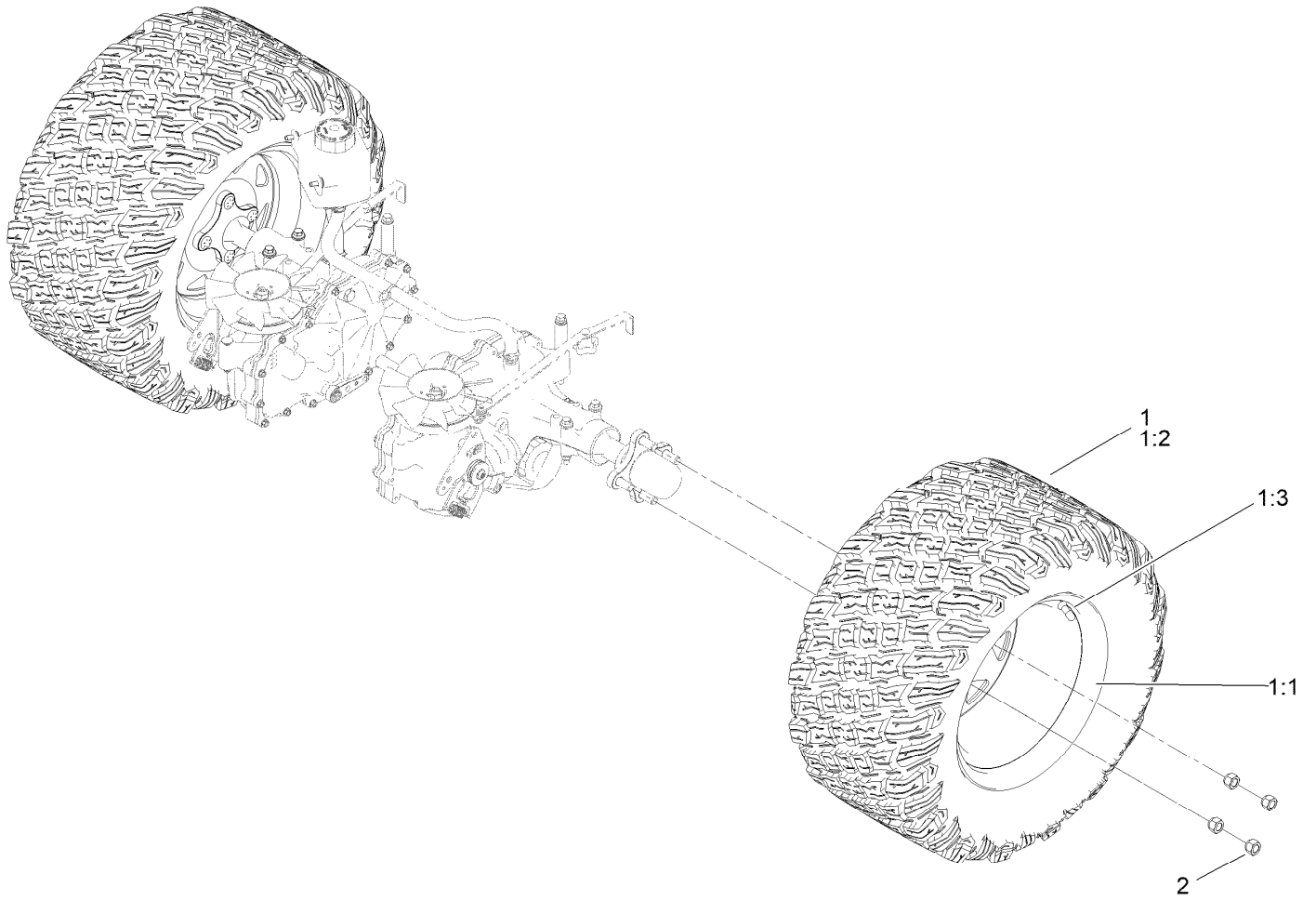

Wheel Assembly (continued)

<i>Ref.</i>	<i>Part Number</i>	<i>Qty.</i>	<i>Description</i>	<i>Ref.</i>	<i>Part Number</i>	<i>Qty.</i>	<i>Description</i>
1	144-1863	2	Tire ASM	1:3	232-27	1	Stem-Valve
1:1	139-3634	1	Wheel	2	242-50	8	Nut-Lug
1:2	144-1864	1	Tire				

Electrical Assembly

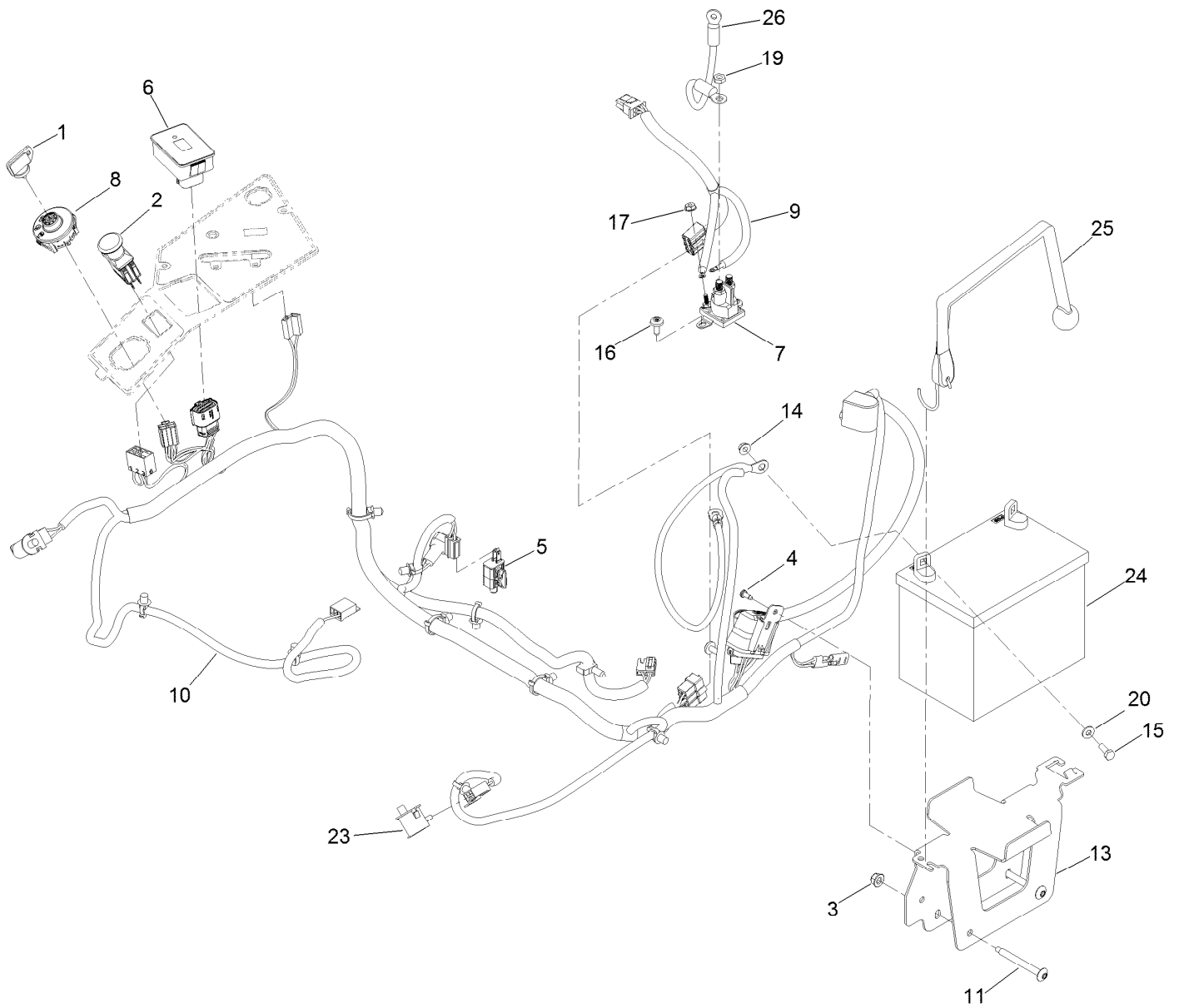

Electrical Assembly (continued)

<i>Ref.</i>	<i>Part Number</i>	<i>Qty.</i>	<i>Description</i>	<i>Ref.</i>	<i>Part Number</i>	<i>Qty.</i>	<i>Description</i>
1	63-8360	1	Key-Ignition	13	126-6725-03	1	Tray-Battery
2	103-5221	1	Switch-PTO	14	32128-33	2	Nut-HF
3	104-8300	2	Nut-HF, NI	15	321-4	2	Screw-HH
4	105-6849	1	Screw-Forming, Thread	16	126-6266	2	Screw-Tph
5	110-6765	1	Switch	17	32149-8	2	Nut-Keps
6	116-5609	1	Module ASM	19	3220-2	1	Nut-Jam
7	117-1197	1	Solenoid	20	3256-22	2	Washer-Flat
8	137-4100	1	Switch-Ignition	23	82-2190	2	Switch-Bail
9	126-5036	1	Adapter-Harness, Wire	24		1	Battery ●■
10	126-5803	1	Harness-Wire ▲	25	142-8697	1	Strap, Bungee
11	126-6267	2	Screw-TTH	26	100-3540	1	Cable-Battery, Positive

● Obtain locally.

■ Not serviced separately

▲ Use dielectric grease on all unsealed connectors and terminals only. Do not apply in sealed connectors.

Harness Assembly No. 126-5803

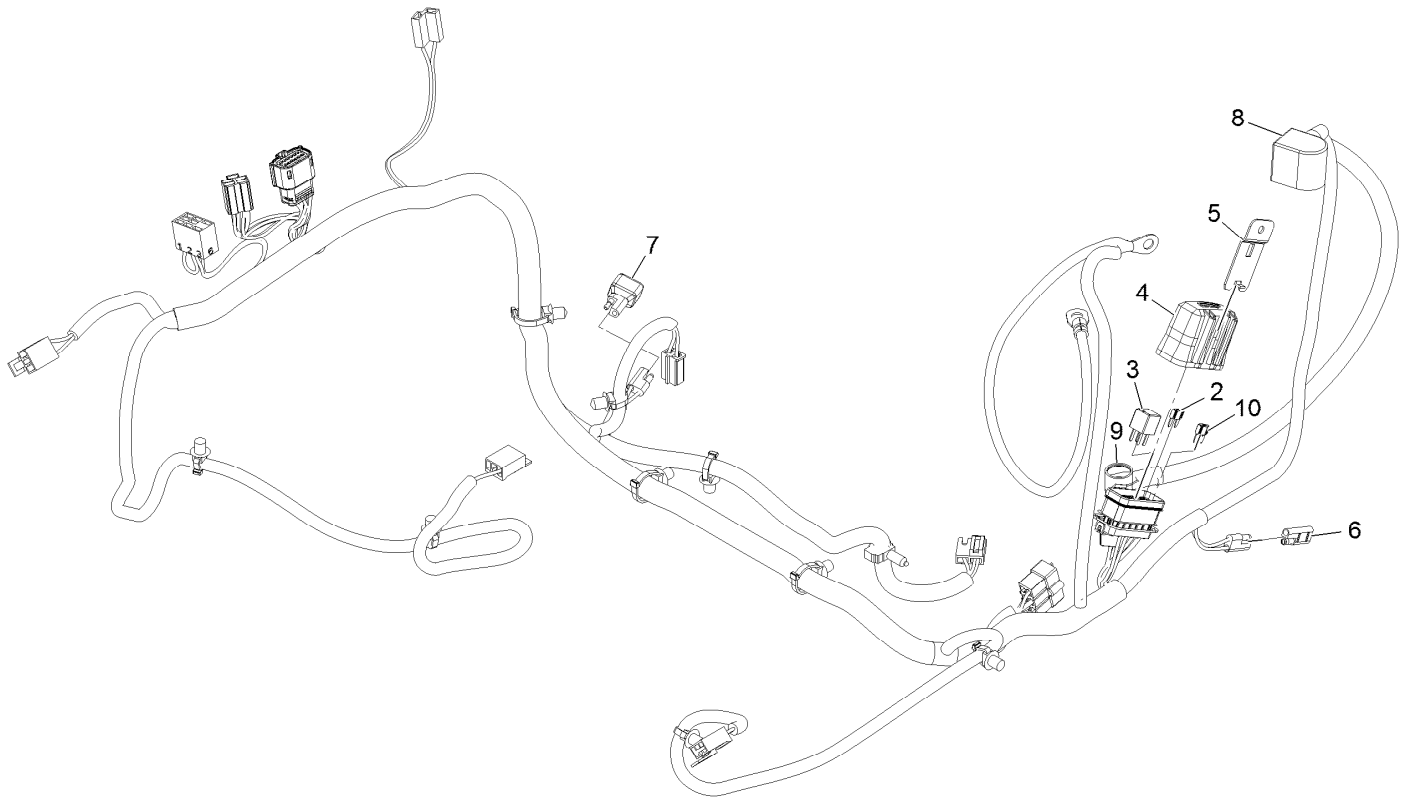

Harness Assembly No. 126-5803 (continued)

<i>Ref.</i>	<i>Part Number</i>	<i>Qty.</i>	<i>Description</i>
2	121-8868	1	Fuse-Mini Blade, 20 Amp
3	126-3991	1	Relay-Micro
4	32180-176	1	Cover-Block, Fuse
5	32180-177	1	Clip-Mounting
6	116-0053	1	Cap-Plug

<i>Ref.</i>	<i>Part Number</i>	<i>Qty.</i>	<i>Description</i>
7	103-3895	1	Diode
8	126-8876	1	Insulator-Battery
9	1-543393	1	Insulator-Solenoid
10	121-8867	1	Fuse-Mini Blade, 15 Amp

Deck Lift Assembly

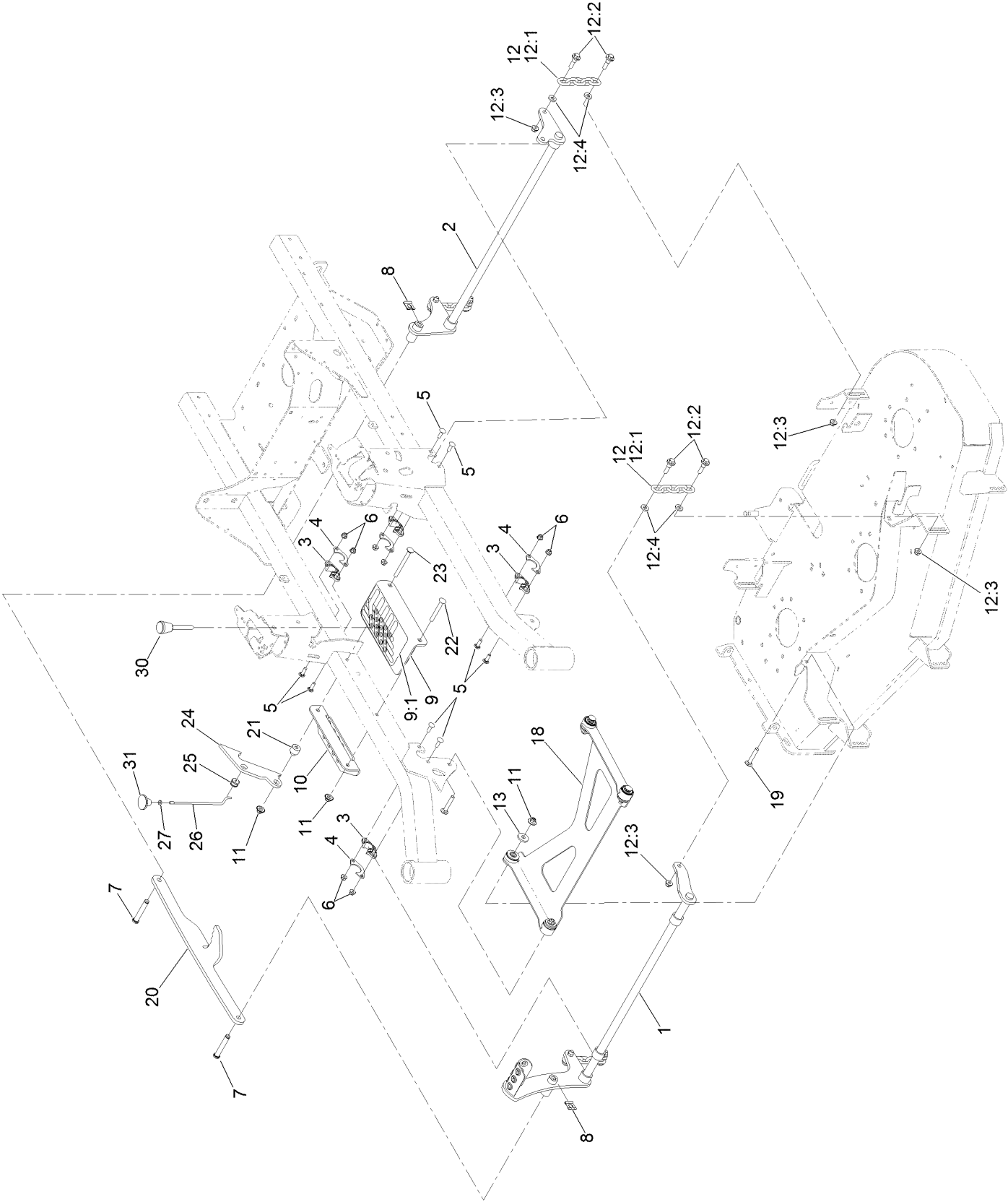

Deck Lift Assembly (continued)

<i>Ref.</i>	<i>Part Number</i>	<i>Qty.</i>	<i>Description</i>	<i>Ref.</i>	<i>Part Number</i>	<i>Qty.</i>	<i>Description</i>
1	126-3342-03	1	Shaft-Lift, Deck	12:3	104-8301	2	Nut-HF, NI
2	126-3343-03	1	Shaft-Lift, Deck (Rear)	12:4	43-0940	2	Spacer
3	115-5065	4	Bushing-Flange	13	1-373034	2	Washer
4	116-2887	4	Gusset-Lift, Deck	18	126-8365	1	Deck Strut ASM
5	3230-22	8	Screw-CARR	19	3231-7	2	Screw-CARR
6	104-8300	8	Nut-HF, NI	20	126-4639-03	1	Link-HOC
7	126-9181	2	Pin-Clevis	21	126-5221	1	Spacer-Stepped
8	138-8491	2	Clip-Pin	22	3231-42	1	Screw-CARR
9	126-4535	1	Bracket ASM	23	135-0313	1	Screw-CARR
9:1	126-4784	1	Decal-HOC	24	126-5222	1	Plate-Lock, Transport
10	126-4640-03	1	Angle-HOC, Lower	25	126-5593	1	Grommet
11	109-6658	4	Nut-Flange, NI	26	126-5223	1	Rod-Lock, Transport
12	126-8877	4	Deck Chain ASM	27	3218-1	1	Nut-Jam
12:1	1-633447	1	Chain-Lift, Deck	30	126-5401	1	Pin-HOC
12:2	130-0742	2	Bolt-Shoulder	31	126-7019	1	Knob

Deck Strut Assembly No. 126-8365

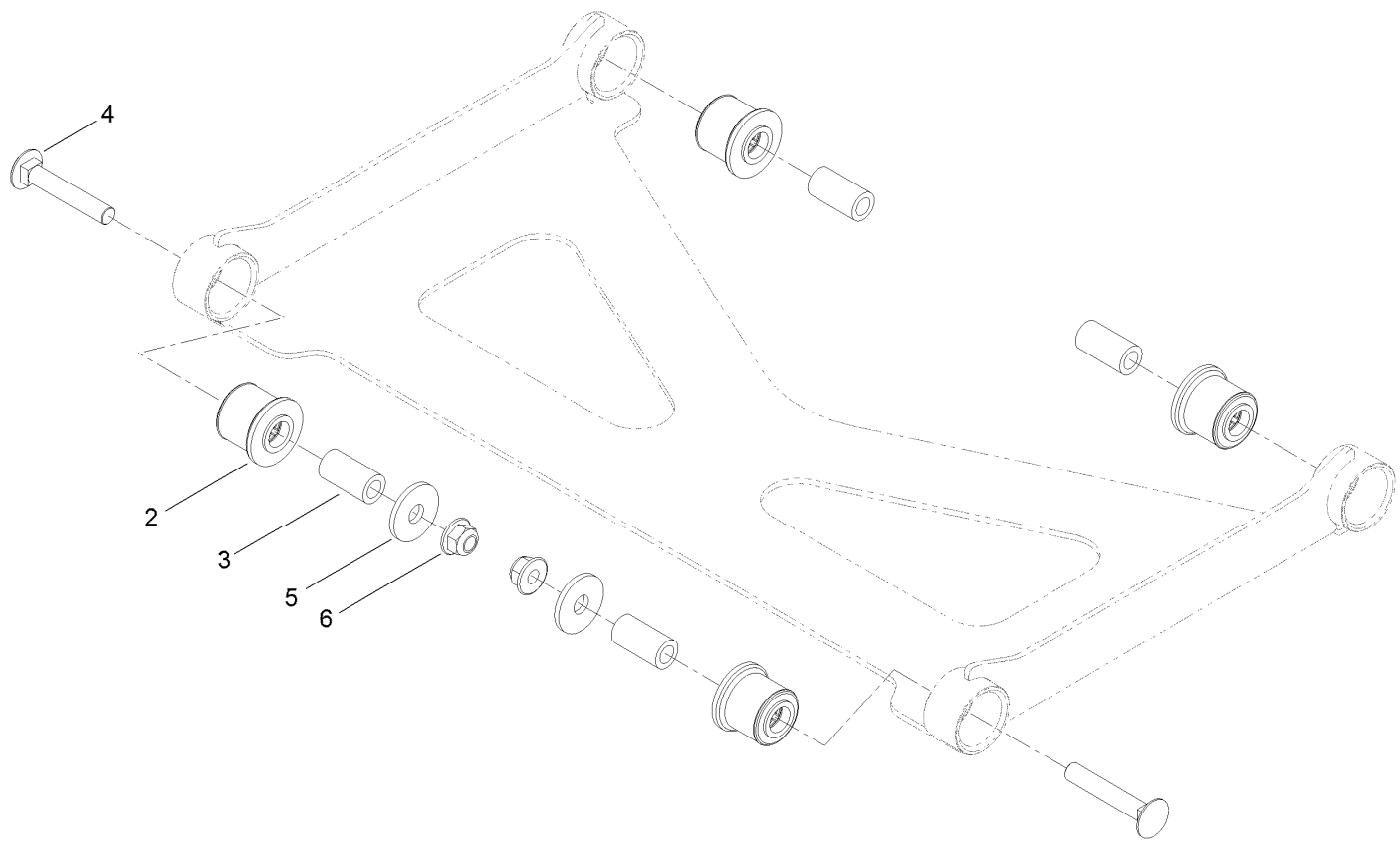

Deck Strut Assembly No. 126-8365 (continued)

<i>Ref.</i>	<i>Part Number</i>	<i>Qty.</i>	<i>Description</i>	<i>Ref.</i>	<i>Part Number</i>	<i>Qty.</i>	<i>Description</i>
2	126-8360	4	Bushing-Rubber, Suspension	4	3231-7	2	Screw-CARR
3	108-6544	4	Spacer	5	2844	2	Washer
				6	104-8301	2	Nut-HF, NI

Engine Assembly

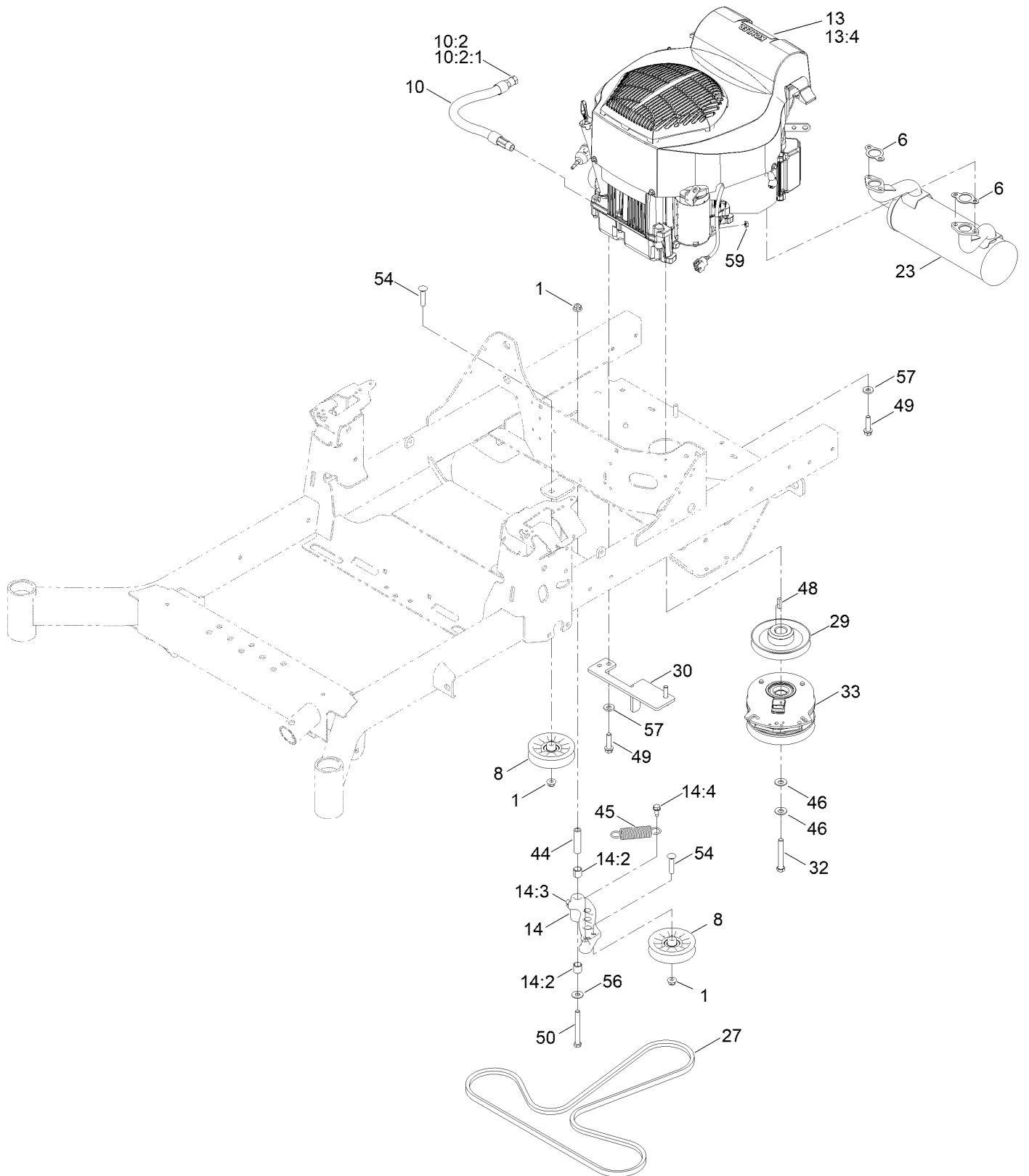

Engine Assembly (continued)

<i>Ref.</i>	<i>Part Number</i>	<i>Qty.</i>	<i>Description</i>	<i>Ref.</i>	<i>Part Number</i>	<i>Qty.</i>	<i>Description</i>
1	104-8301	3	Nut-HF, NI	29	135-0134	1	Sheave-Engine
6	1-653291	2	Gasket-Exhaust	30	126-6687-03	1	Anchor-Clutch
8	116-2456	2	Pulley-Flat Idler	32	126-7198	1	Screw-HH W/Loctite ○
10	116-5108	1	Oil Drain Hose ASM ▲	33	127-3410	1	Clutch-PTO
10:2	353-508	1	Plug-HH ■	44	1-603384	1	Bushing-Pivot, Idler
10:2:1	237-42	1	O-Ring	45	1-603402	1	Spring-Extension
13		1	Engine-Kohler Kt745 ◆ □	46	1-603610	2	Washer-Spring
13:4	281-1	1	Plug-Pipe, SQH ●	48	1-807259	1	Key
14	126-0973	1	Idler Arm ASM	49	32144-109	4	Screw-Thd
14:2	1-513034	2	Sleeve-Bearing	50	323-15	1	Screw-HH
14:3	302-40	1	Fitting-Grease, 90 DEG	54	3231-29	2	Screw-CARR
14:4	32144-11	1	Screw-HWH	56	3256-4	1	Washer-Flat
23	126-4359	1	Muffler-Kohler Aes	57	98-5975	4	Washer-Belleville
27	126-5993	1	Belt-V	59	32128-33	1	Nut-HF

● Not illustrated

▲ Torque to 17-23 ft-lb

□ Obtain parts from www.kohlerplus.com

○ Use Pro-Lock, Nut Type (P/N 1-840022, .5ml tube) on threads.

■ Torque to 24-26 ft-lb

◆ Not serviced separately

60in Deck Assembly

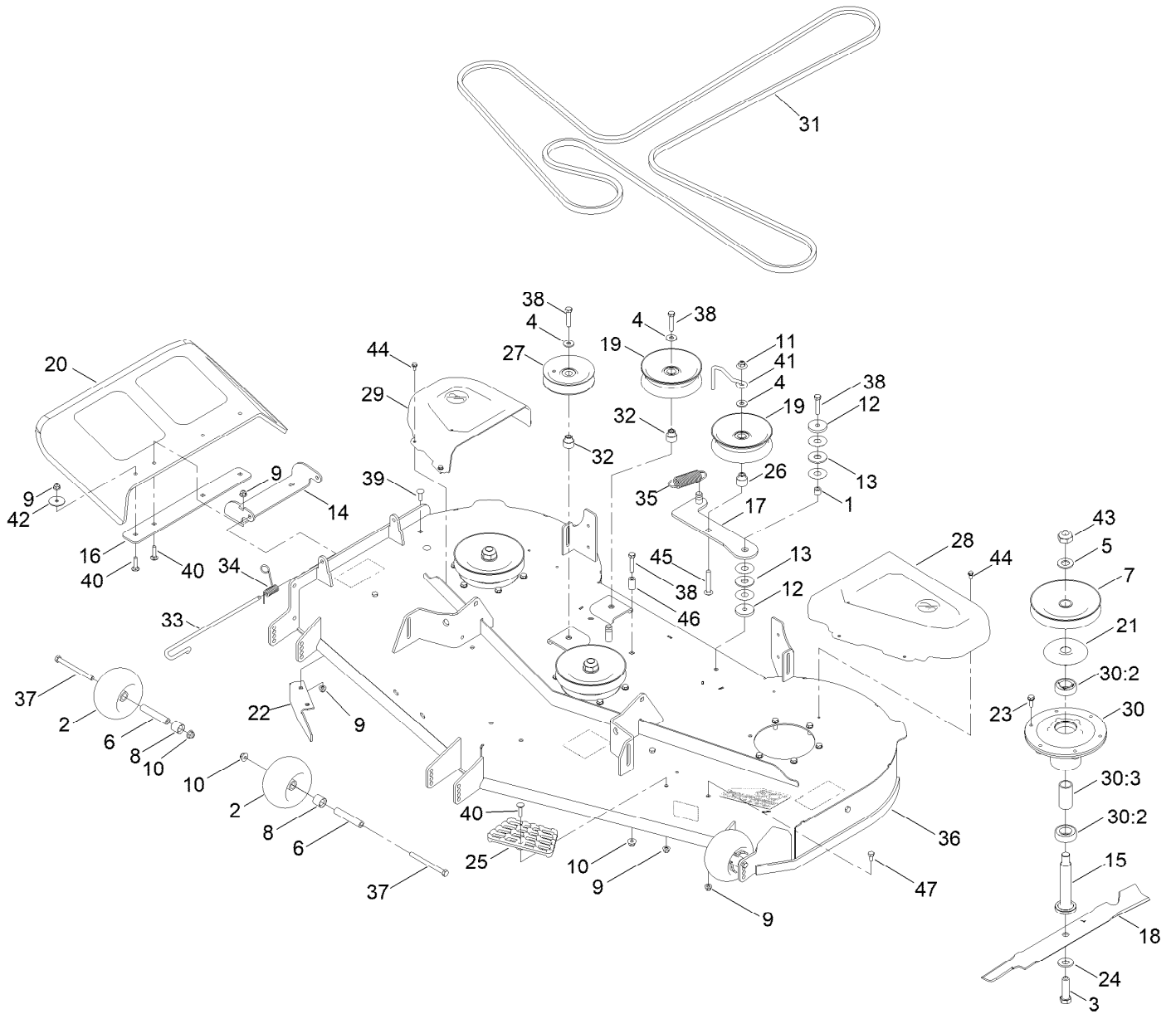

60in Deck Assembly (continued)

<i>Ref.</i>	<i>Part Number</i>	<i>Qty.</i>	<i>Description</i>	<i>Ref.</i>	<i>Part Number</i>	<i>Qty.</i>	<i>Description</i>
1	1-413088	1	Bushing-Lever, Lift	26	126-7684	1	Bushing-Idler
2	1-603299	3	Roller-Scalp, Anti	27	132-4718	1	Pulley-Idler, Flat
3	51-4060	3	Screw-Blade	28	133-9282	1	Cover-Belt, LH
4	80-6990	3	Washer-Hardened	29	133-9283	1	Cover-Belt, RH
5	92-5836	3	Washer	30	120-5477	3	Spindle ASM
6	98-7912	3	Tube-Spanner	30:2	116-0720	2	Bearing-Ball
7	135-0363	3	Sheave-Drive, Blade	30:3	115-2641	1	Spacer-Bearing
8	104-0892	3	Spacer-Axle, Rear	31	135-1873	1	Belt-Deck Drive
9	104-8300	11	Nut-HF, NI	32	138-7227	2	Bushing-Idler
10	104-8301	4	Nut-HF, NI	33	138-7231	1	Pin-Chute
11	109-6658	2	Nut-Flange, NI	34	138-7232	1	Spring-Torsion
12	110-9981	2	Washer-Plain	35	139-3616	1	Spring - Extension
13	114-0463	2	Washer-Friction, Composite	36	144-1895	1	Deck ASM - 60
14	114-1648-03	1	Bracket-Deflector, Upper	37	323-23	3	Screw-HH
15	115-2642	3	Shaft-Spindle	38	323-9	4	Screw-HH
16	115-5048-03	1	Plate-Deflector	39	3230-22	2	Screw-CARR
17	115-5054	1	Arm-Idler	40	3230-3	5	Screw-CARR
18	115-9649-03	3	Blade-Hi Flow	41	144-1980	1	Belt Guide - Idler
19	116-4669	2	Idler-Pulley, Flat	42	3256-68	2	Washer-Flat
20	117-1270	1	Deflector	43	3296-67	3	Nut-Lock, NI
21	117-7210	3	Shield-Bearing	44	32144-4	8	Screw-HWH
22	119-3388-03	1	Baffle-Cutoff	45	3231-44	1	Screw-CARR
23	32144-41	18	Screw-Taptite	46	1-603401	1	Spacer
24	125-1736	3	Washer-Belleville	47	3234-5	4	Screw-HHF
25	126-4781-03	1	Step-Deck				

60in Deck Decal Assembly No. 144-1895

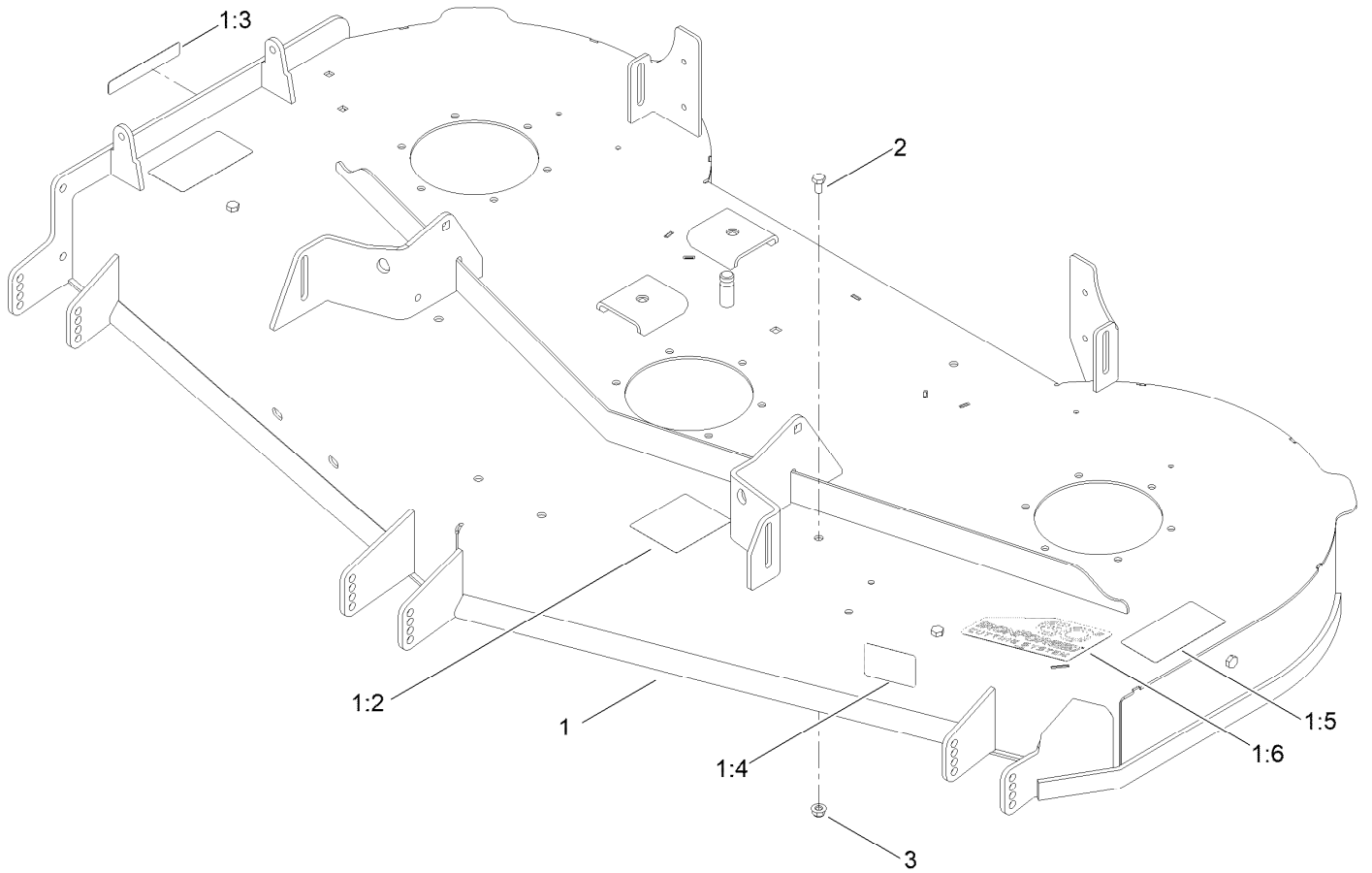

60in Deck Decal Assembly No. 144-1895 (continued)

<i>Ref.</i>	<i>Part Number</i>	<i>Qty.</i>	<i>Description</i>	<i>Ref.</i>	<i>Part Number</i>	<i>Qty.</i>	<i>Description</i>
1		1	Deck ASM W/Decals 60 ●	1:5	132-0872	2	Decal-Danger, Deck
1:2	117-1194	1	Decal-Routing, Belt	1:6	139-3256	1	Decal - Deck
1:3	130-0731	1	Decal-Danger	2	322-2	4	Screw-HH
1:4	130-0765	1	Decal-Scalp, Anti	3	104-8300	4	Nut-HF, NI

● Not serviced separately

Attachments and Accessories

For 76601 60in TITAN MAX Riding Mower

Product Name	Model/Part
Hypr-Oil 500 (quart)	114-4713
Hypr-Oil 500 (gallon).....	114-4714
Hypr-Oil 500-5 (5 gallon).....	114-4715
Toro Hydro Kit	121-3783
Cover-Hitch.....	126-8299
Weight Caster Kit.....	126-8639
Jack Kit	127-6666
Fuel Stabilizer .05 oz	130-2393
4-Cycle Fuel, Snow And Lawn 32oz Can	131-3823
Toro Premium Fuel Treatment 12oz Bottle	131-6572
Hi-Back Seat Cover	133-1308
60in Recycler Kit.....	136-7490
Spark Arrestor, 1.25 I.D.	137-8098
Suspension Seat	139-3626
Tweel-Turf Tire.....	139-3649
Semi Pneumatic Wheel and Tire Assembly, 13x6.50-6	140-4896
Hd Bagger Cover Kit.....	140-5036
Leaf Bagging Enhancement Kit	140-5122
Tilt Sensor-Radius	142-2802
Light Kit (mid-mount ZRT Mower)	144-1992
Jack Mount Kit	144-1993
Hardtop Sun Canopy	144-3719
Handle Extension Kit	145-3615
Toro Deluxe Rider Cover.....	490-7319
Powered Bagger.....	79347

Notes:

Notes:

Notes:



Count on it.