



15in Trim and Edge Electric Trimmer

Model No. 51357—230000001 and Up

Parts Catalog

Ordering Replacement Parts

To order replacement parts, please supply: the part number, the quantity, and the description of each part desired.

Understanding Reference Numbers

Each identified part in an illustration has a reference number. The reference number for a part also appears in the parts list, along with other information about the part.

This catalog uses two special reference number formats, one to indicate parts in a service assembly and another to indicate the quantity of a given part in an illustration.

Service Assembly Reference Numbers

Parts in service assemblies have reference numbers in the form **a:b**. The **a** represents the reference number of the entire service assembly and the **b** represents a sequential number unique to each part within the service assembly.

For example, a wheel assembly might be identified by reference number **6**, the tire by **6:1**, the valve by **6:2**, and the wheel by **6:3**. When you order the assembly identified by reference number **6**, you receive all parts identified by reference numbers **6:1**, **6:2**, and **6:3**. However, you may also order any part individually.

Reference numbers of this type appear in illustrations and in part lists.

Reference Numbers Indicating Quantity

In an illustration, if a reference number indicates more than one part, the reference number has the form **nX y**. The **n** represents the quantity of the part, the **X** is the multiplication symbol, and the **y** represents the reference number.

For example, in an illustration, the reference number **2X 37** means that two of the parts identified by reference number **37** are indicated.

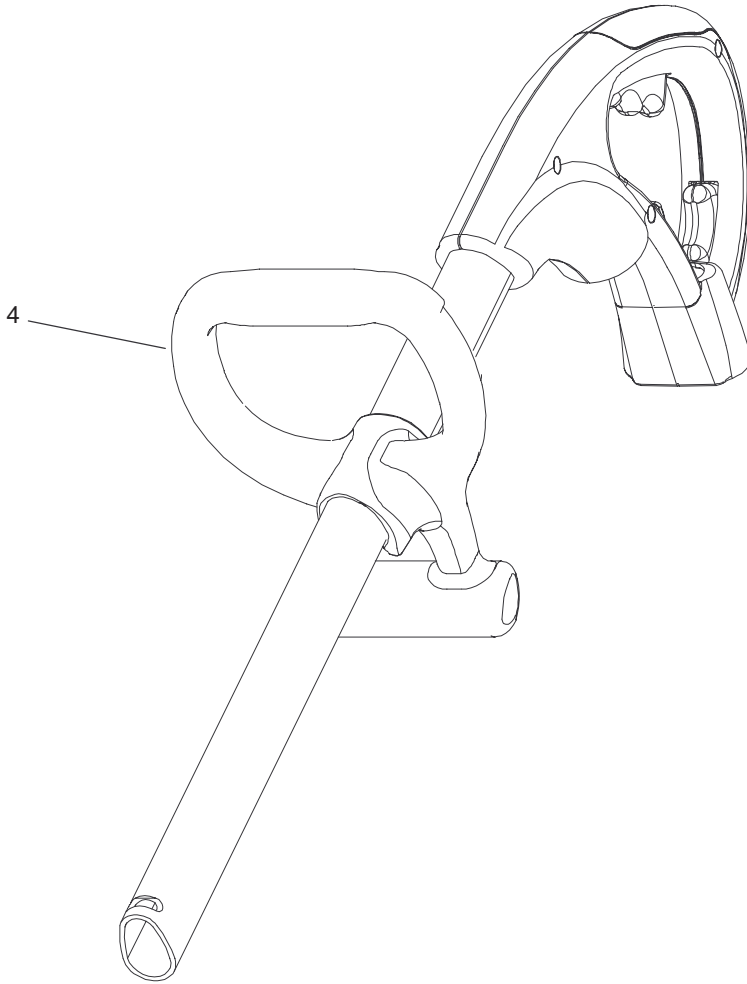

Sheet No.:2

Handle and Tube Assembly

Ref. No.	Part No.	Qty.	Description
4	105-9417	1	Handle-Assist, Flip

Ref. No.	Part No.	Qty.	Description
----------	----------	------	-------------

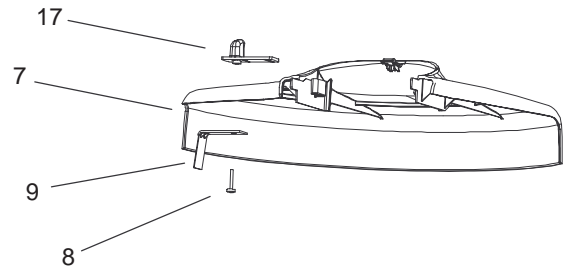
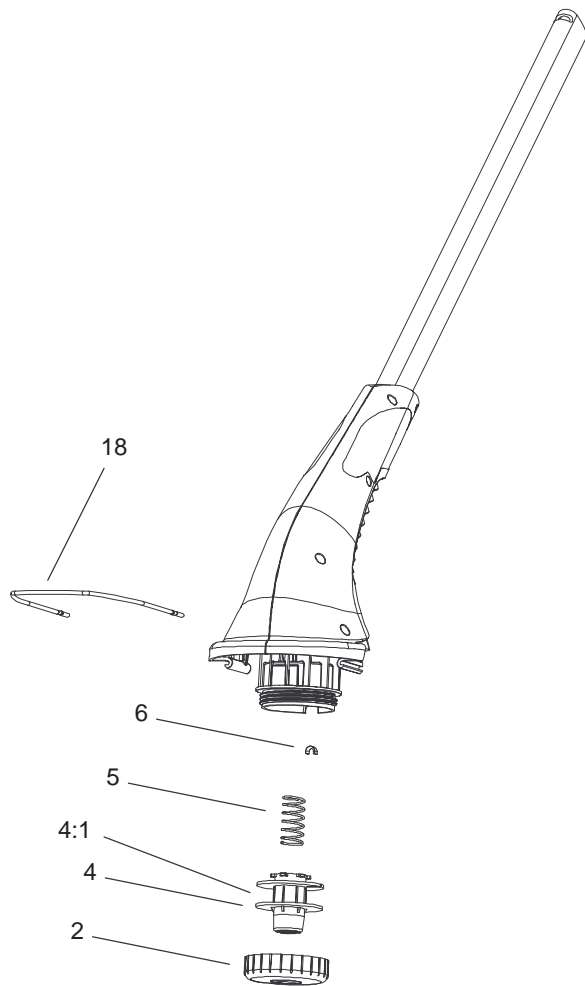

Sheet No.:3

Motor and Cutting Shield Assembly

Ref. No.	Part No.	Qty.	Description
2	105-9422	1	Cap-Drum
4	73-8490	1	.065 Spool ASM
4:1	73-8190	1	Spool-Large
*4:2	7420625	31	Filament Line
5	105-9423	1	Spring-Extension
6	105-9424	1	Eyelet-Drum
7	105-9438	1	Shield-Variable Cut (14in)
8	94-4496	12	Screw-PPH
9	105-9439	1	Blade-Variable Cut
17	105-9440	1	Slide-Variable Cut
18	105-9427	1	Guide-Edge

Ref. No.	Part No.	Qty.	Description

* Not illustrated

