



**Count on it.**

**Parts Catalog**

**Power Max<sup>®</sup> e24 60V  
Snowthrower**

Model No. 39924—Serial No. 400000000 and Up



# Ordering Replacement Parts

To order replacement parts, please supply the part number, the quantity, and the description of each part desired.

## Understanding Reference Numbers

Each identified part in an illustration has a reference number. The reference number for a part also appears in the parts list, along with other information about the part.

This catalog uses two special reference number formats, one to indicate parts in a service assembly and another to indicate the quantity of a given part in an illustration.

## Service Assembly Reference Numbers

Parts in service assemblies have reference numbers in the form a:b. The a represents the reference number of the entire service assembly and the b represents a sequential number unique to each part within the service assembly.

For example, a wheel assembly might be identified by reference number 6, the tire by 6:1, the valve by 6:2, and the wheel by 6:3. When you order the assembly identified by reference number 6, you receive all parts identified by reference numbers 6:1, 6:2, and 6:3. However, you may also order any part individually. Reference numbers of this type appear in illustration and in parts lists.

## Reference Numbers Indicating Quantity

In an illustration, if a reference number indicates more than one part, the reference number has the form nX y. The n represents the quantity of the part, the X is the multiplication symbol, and the y represents the reference number.

For example, in an illustration, the reference number 2X 37 means that two of the parts identified by reference number 37 are indicated.

# Contents

|  |    |
|--|----|
| Main Frame and Auger Housing Assembly .....        | 4  |
| Pulley and Bellcrank Assembly .....                | 6  |
| Impeller Drive Assembly .....                      | 8  |
| Drive Assembly .....                               | 10 |
| Gearbox, Auger and Impeller Assembly .....         | 12 |
| 24 Inch Auger Gearcase Assembly No. 120-3859 ..... | 14 |
| Impeller Assembly .....                            | 16 |
| Powerhead, Pulley and Belt Assembly .....          | 18 |
| 60 Volt Powerhead Assembly No. 139-5315 .....      | 20 |
| Chute Assembly .....                               | 22 |
| Lever Chute Control Assembly .....                 | 24 |
| Handle Assembly .....                              | 26 |
| Attachments and Accessories .....                  | 28 |

# Main Frame and Auger Housing Assembly

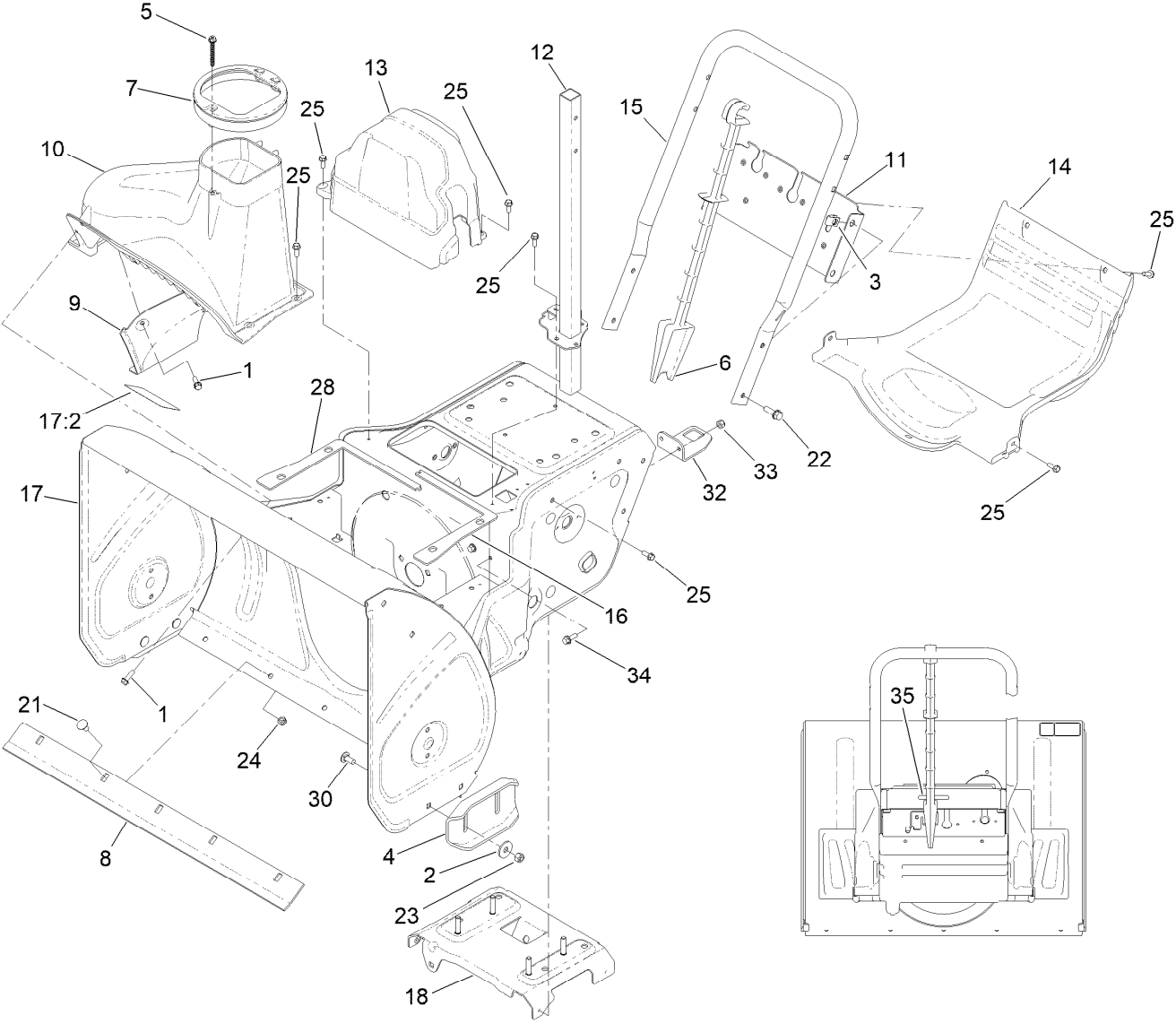

## Main Frame and Auger Housing Assembly (continued)

| <i>Ref.</i> | <i>Part Number</i> | <i>Qty.</i> | <i>Description</i>  | <i>Ref.</i> | <i>Part Number</i> | <i>Qty.</i> | <i>Description</i>  |
|-------------|--------------------|-------------|---------------------|-------------|--------------------|-------------|---------------------|
| 1           | 46-8091            | 6           | Screw-HWH           | 16          | 120-7181           | 1           | Seal-Housing, LH    |
| 2           | 52-2861            | 4           | Washer              | 17          | 147-9470           | 1           | Frame ASM           |
| 3           | 94-2413            | 4           | Nut-U               | 17:2        | 121-6817           | 1           | Decal-Danger, Auger |
| 4           | 106-4588-01        | 2           | Skid                | 18          | 139-5270           | 1           | Brace-Frame         |
| 5           | 114-3751           | 1           | Screw-HWH, Plastite | 21          | 3230-18            | 5           | Screw-CARR          |
| 6           | 121-6833           | 1           | Stick-Cleanout      | 22          | 3234-29            | 4           | Screw-HHF           |
| 7           | 138-3608           | 1           | Guide-Chute         | 23          | 3296-29            | 4           | Nut-Lock, NI        |
| 8           | 119-7601-01        | 1           | Scraper-24 Inch     | 24          | 3296-47            | 5           | Nut-Lock,NI         |
| 9           | 120-7158-01        | 1           | Cover-Liner         | 25          | 32144-85           | 17          | Screw-HWH Thd Form  |
| 10          | 120-7159           | 1           | Cover               | 28          | 121-6841           | 1           | Seal-Housing, RH    |
| 11          | 120-7161-01        | 1           | Brace-Frame         | 30          | 3230-23            | 4           | Bolt-CARR           |
| 12          | 137-3412-03        | 1           | Support-Chute       | 32          | 137-3410-03        | 1           | Bracket-Post, Chute |
| 13          | 120-7177           | 1           | Cover-Belt          | 33          | 120-9678           | 2           | Screw-HHF           |
| 14          | 120-7178           | 1           | Cover-Lower         | 34          | 137-3094           | 2           | Nut-Hex             |
| 15          | 140-3740-03        | 1           | Handle-Lower, Cts   | 35          | 133-8061           | 1           | Decal-Warning       |

# Pulley and Bellcrank Assembly

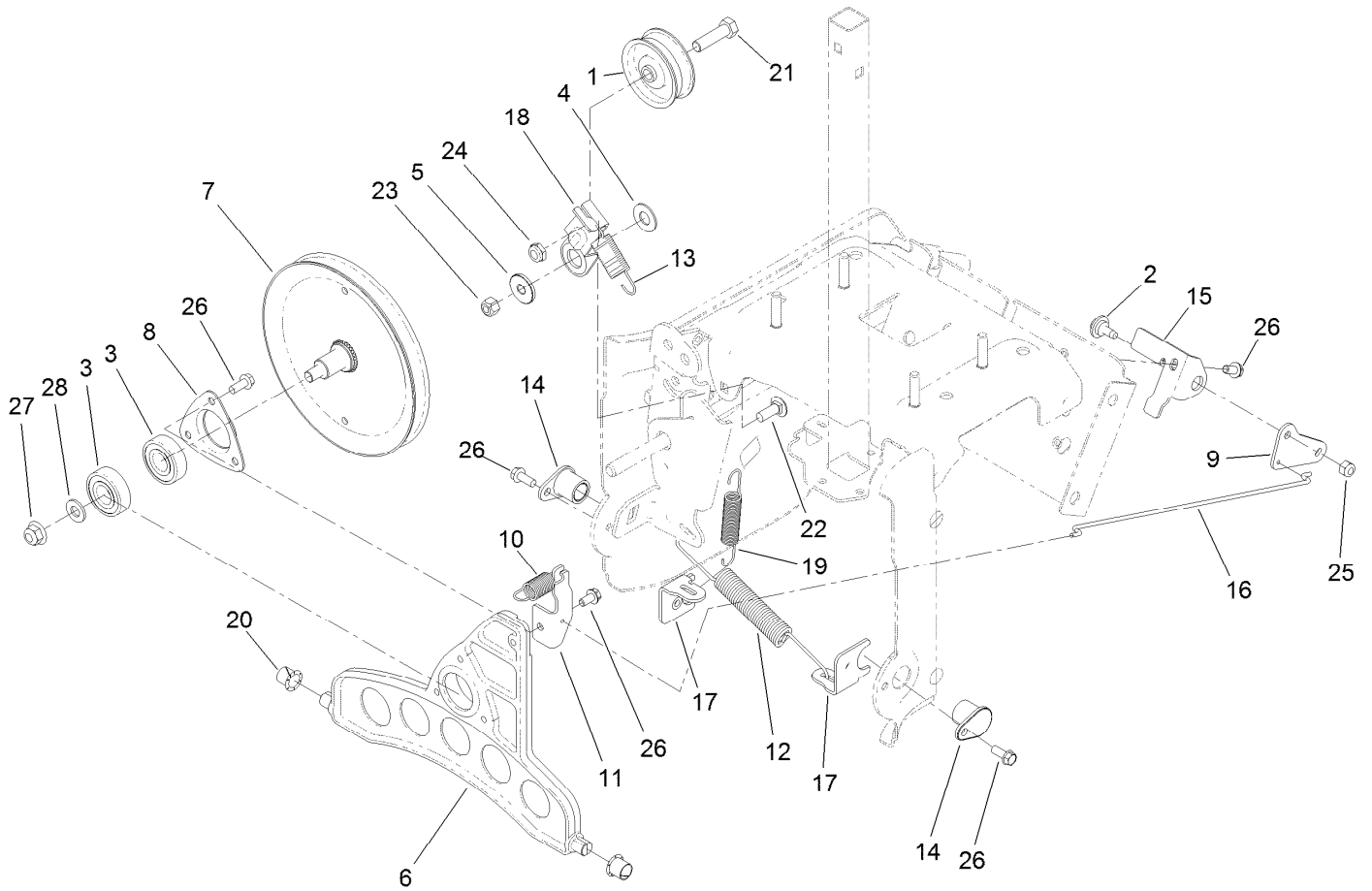

## Pulley and Bellcrank Assembly (continued)

| <i>Ref.</i> | <i>Part Number</i> | <i>Qty.</i> | <i>Description</i>      | <i>Ref.</i> | <i>Part Number</i> | <i>Qty.</i> | <i>Description</i>     |
|-------------|--------------------|-------------|-------------------------|-------------|--------------------|-------------|------------------------|
| 1           | 3-4244             | 1           | Pulley-Idler            | 15          | 120-7165-03        | 1           | Bracket-Bellcrank      |
| 2           | 92-9698            | 1           | Screw-Shoulder          | 16          | 136-7155           | 1           | Link-Drive             |
| 3           | 38-7820            | 2           | Bearing-Ball            | 17          | 120-9271           | 2           | Bracket-Anchor, Spring |
| 4           | 25-5640            | 1           | Washer                  | 18          | 136-7159           | 1           | Arm-Idler, Traction    |
| 5           | 117-7711           | 1           | Bushing-Idler           | 19          | 120-9275           | 1           | Spring-Extension       |
| 6           | 119-7645           | 1           | Plate-Wheel, Friction   | 20          | 256-257            | 2           | Bushing-Nyliner        |
| 7           | 136-7152           | 1           | Traction Pulley ASM     | 21          | 323-29             | 1           | Screw-HH               |
| 8           | 136-7124           | 1           | Retainer-Bearing        | 22          | 3230-10            | 1           | Bolt-CARR              |
| 9           | 119-7670-03        | 1           | Bellcrank-Drive         | 23          | 3296-29            | 1           | Nut-Lock, NI           |
| 10          | 136-7153           | 1           | Spring-Extension        | 24          | 3296-59            | 1           | Nut-Lock, NI           |
| 11          | 119-7679           | 1           | Bracket-Plate, Traction | 25          | 3296-73            | 1           | Nut-Lock, NI           |
| 12          | 120-3883           | 1           | Spring-Extension        | 26          | 32144-85           | 7           | Screw-HWH Thd Form     |
| 13          | 137-3435           | 1           | Spring-Extension        | 27          | 104-8301           | 1           | Nut-HF, NI             |
| 14          | 120-7156           | 2           | Bushing-Plate, Traction | 28          | 3256-24            | 1           | Washer-Plain           |

# Impeller Drive Assembly

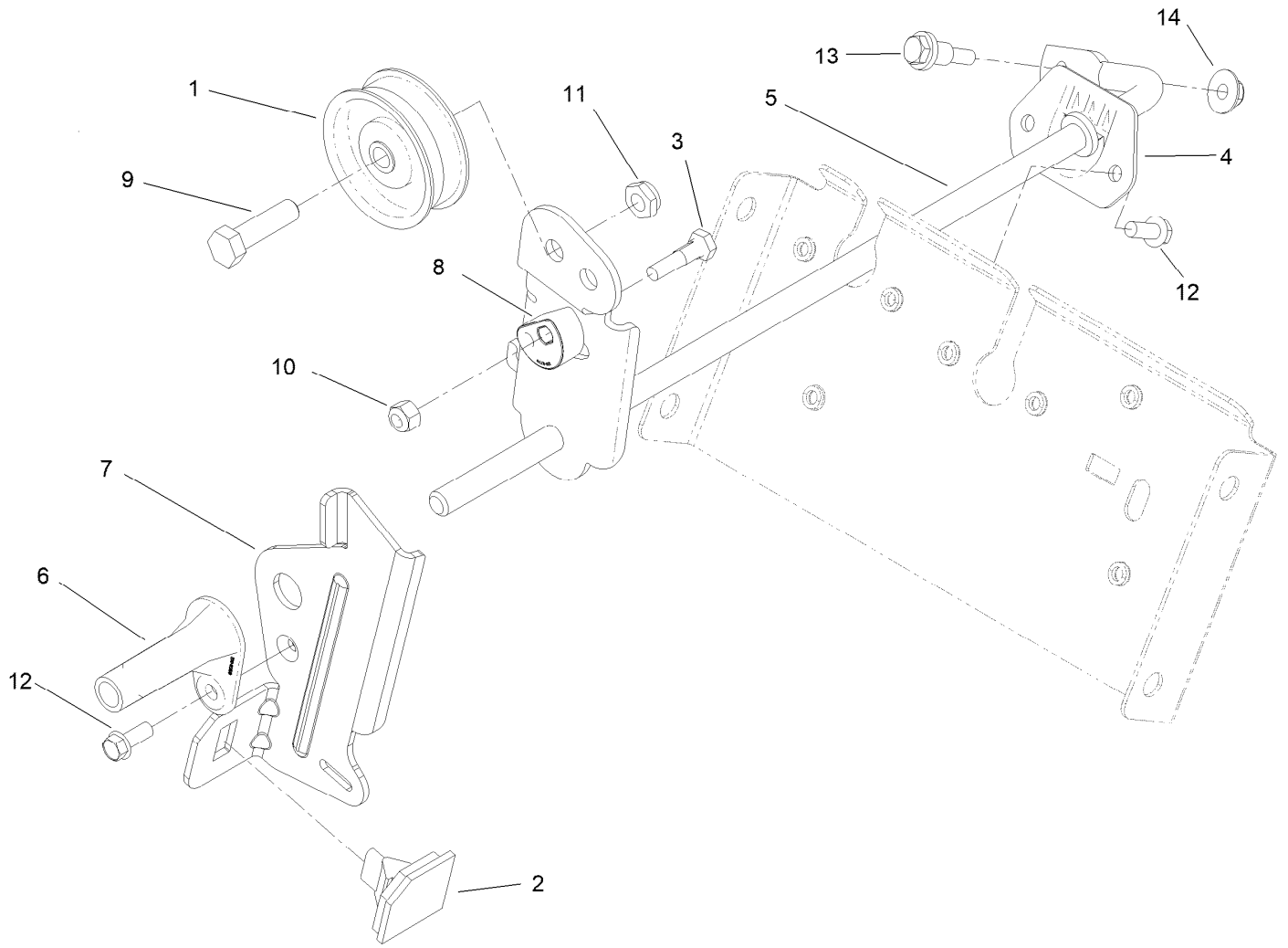



## Impeller Drive Assembly (continued)

| <i>Ref.</i> | <i>Part Number</i> | <i>Qty.</i> | <i>Description</i>    | <i>Ref.</i> | <i>Part Number</i> | <i>Qty.</i> | <i>Description</i>        |
|-------------|--------------------|-------------|-----------------------|-------------|--------------------|-------------|---------------------------|
| 1           | 3-4244             | 1           | Pulley-Idler          | 8           | 120-9276           | 1           | Eccentric-Brake, Impeller |
| 2           | 66-8060            | 1           | Pad-Brake             | 9           | 323-29             | 1           | Screw-HH                  |
| 3           | 136-8674           | 1           | Bolt-Pivot, Eccentric | 10          | 3296-42            | 1           | Nut-Lock, NI              |
| 4           | 120-7167           | 1           | Bushing-Rod, Clutch   | 11          | 3296-59            | 1           | Nut-Lock, NI              |
| 5           | 120-9254-03        | 1           | Impeller Clutch ASM   | 12          | 32144-85           | 3           | Screw-HWH Thd Form        |
| 6           | 120-9256           | 1           | Pivot-Brake, Impeller | 13          | 104-0858           | 1           | Bolt-Shoulder             |
| 7           | 120-9257-03        | 1           | Arm-Brake, Impeller   | 14          | 137-3016           | 1           | Nut-HF                    |

# Drive Assembly

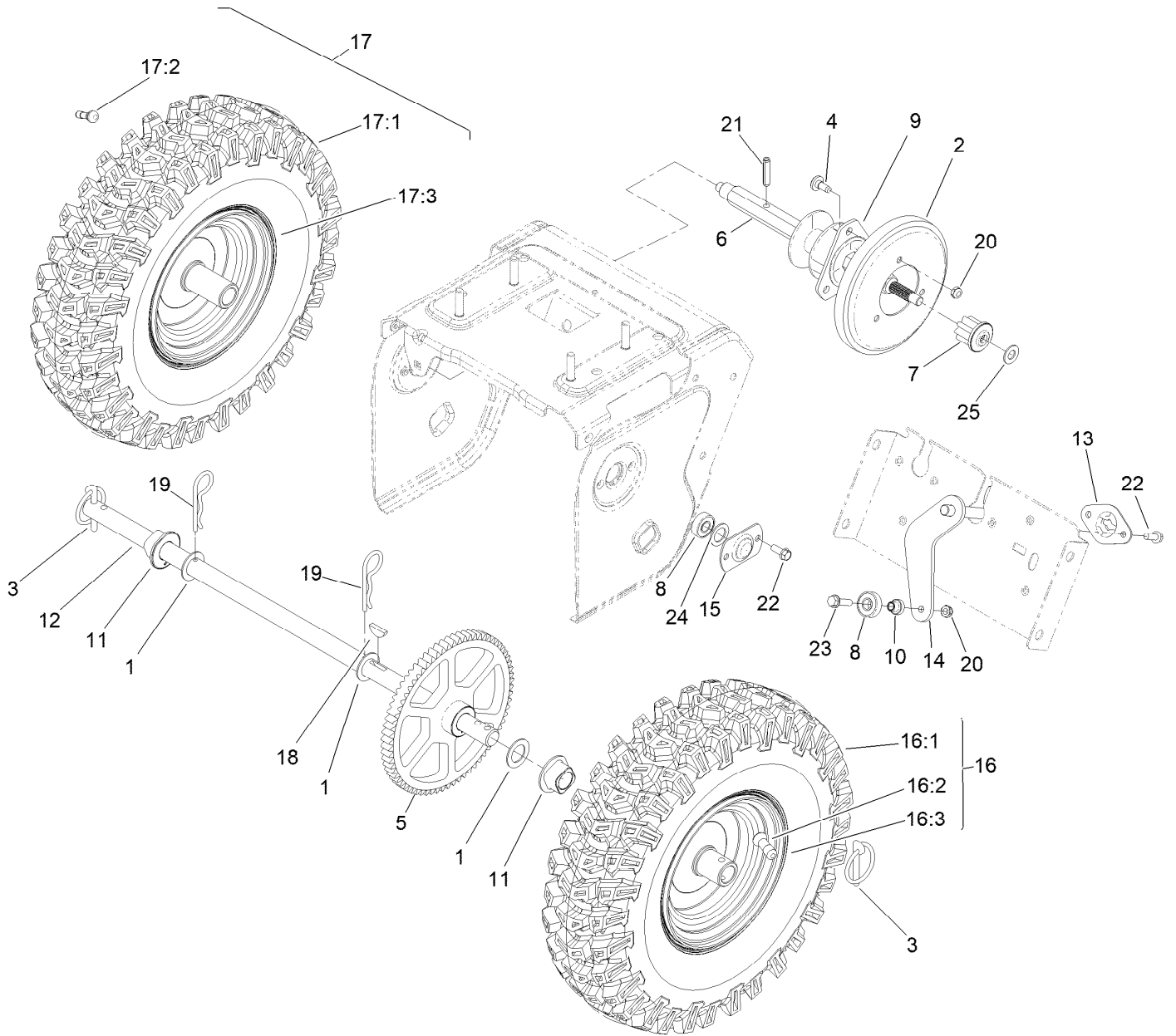

## Drive Assembly (continued)

| <i>Ref.</i> | <i>Part Number</i> | <i>Qty.</i> | <i>Description</i>    | <i>Ref.</i> | <i>Part Number</i> | <i>Qty.</i> | <i>Description</i>    |
|-------------|--------------------|-------------|-----------------------|-------------|--------------------|-------------|-----------------------|
| 1           | 3-8664             | 3           | Washer-Thrust         | 16:1        | 138-3669           | 1           | Wheel (15X4 Tire)     |
| 2           | 119-1567           | 1           | Wheel-Friction        | 16:2        | 232-27             | 1           | Stem-Valve            |
| 3           | 107-3039           | 2           | Pin-Lynch             | 16:3        | 138-3668           | 1           | Tire                  |
| 4           | 120-7950           | 3           | Screw-Torx            | 17          | 138-3659           | 1           | RH Wheel And Tire ASM |
| 5           | 119-7613           | 1           | Gear-Axle             | 17:1        | 138-3669           | 1           | Wheel (15X4 Tire)     |
| 6           | 140-3745           | 1           | Shaft-Hex             | 17:2        | 232-27             | 1           | Stem-Valve            |
| 7           | 119-7616           | 1           | Gear-Pinion, 8 Tooth  | 17:3        | 138-3668           | 1           | Tire                  |
| 8           | 121-6835           | 3           | Bearing-Ball          | 18          | 3257-7             | 1           | Key-Woodruff          |
| 9           | 119-7630           | 1           | Trunnion              | 19          | 3290-343           | 2           | Pin-Hair              |
| 10          | 119-7684           | 1           | Spacer-Plate, Shift   | 20          | 3296-56            | 4           | Nut-Lock, NI          |
| 11          | 120-7162           | 2           | Bushing-Axle          | 21          | 32121-9            | 1           | Pin-Roll, Slotted     |
| 12          | 120-7180           | 1           | Axle                  | 22          | 32144-85           | 6           | Screw-HWH Thd Form    |
| 13          | 120-7191           | 1           | Retainer-Plate, Shift | 23          | 32144-86           | 1           | Screw-HWHTF           |
| 14          | 120-7193-03        | 1           | Shift Plate ASM       | 24          | 121-6840           | 2           | Washer-Rubber         |
| 15          | 136-7158           | 2           | Retainer-Bearing      | 25          | 145-0743           | 1           | Washer-Flat           |
| 16          | 138-3660           | 1           | LH Wheel And Tire ASM |             |                    |             |                       |

# Gearbox, Auger and Impeller Assembly

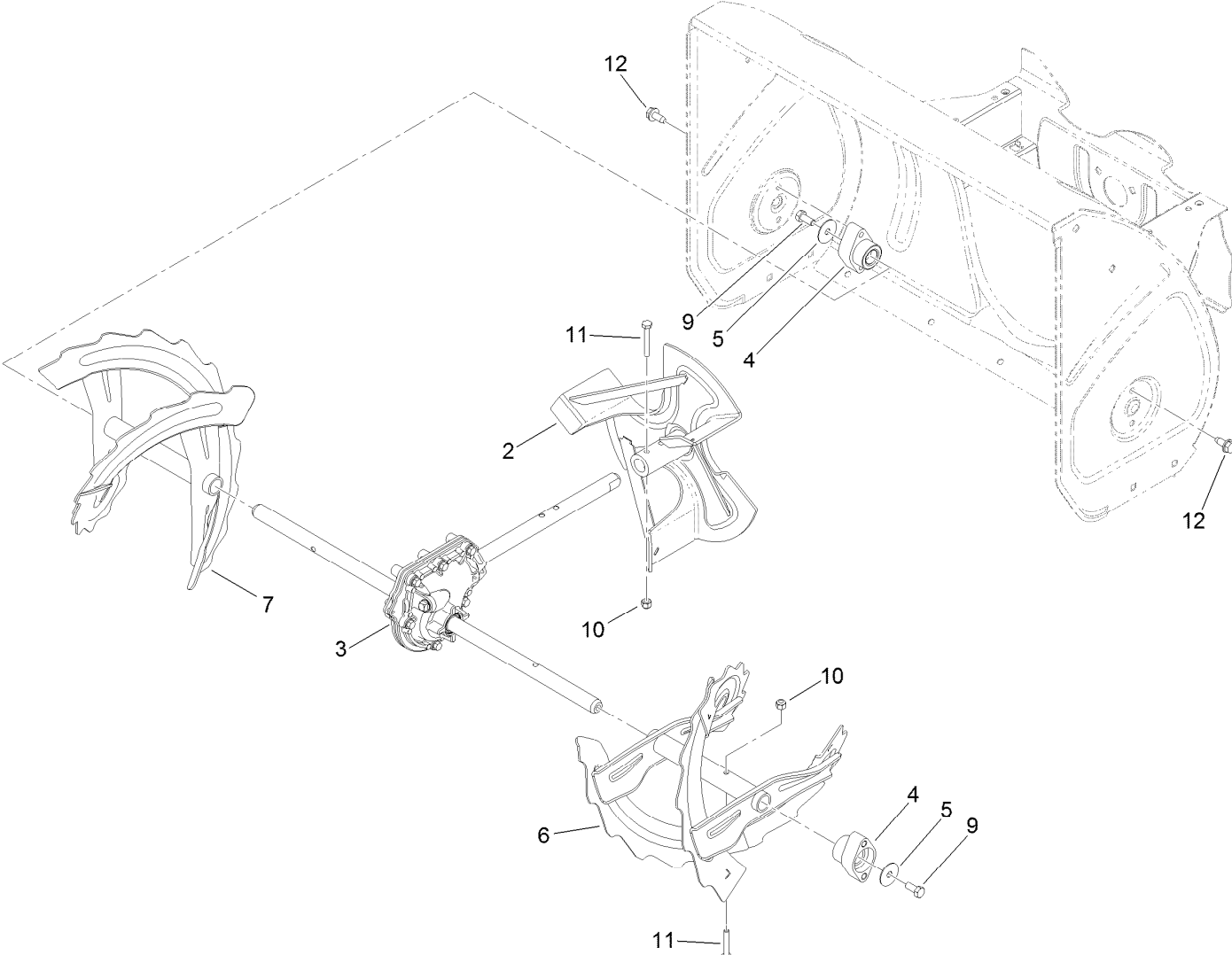

## Gearbox, Auger and Impeller Assembly (continued)

| <i>Ref.</i> | <i>Part Number</i> | <i>Qty.</i> | <i>Description</i> | <i>Ref.</i> | <i>Part Number</i> | <i>Qty.</i> | <i>Description</i> |
|-------------|--------------------|-------------|--------------------|-------------|--------------------|-------------|--------------------|
| 2           | 119-7612-03        | 1           | Impeller ASM       | 7           | 120-9290-03        | 1           | RH Auger ASM       |
| 3           | 120-3859           | 1           | Gearcase ASM       | 9           | 322-3              | 2           | Screw-HH           |
| 4           | 120-3860           | 2           | Bearing-Augur      | 10          | 3296-42            | 4           | Nut-Lock, NI       |
| 5           | 120-3862           | 2           | Washer-Thrust      | 11          | 321-10             | 4           | Screw-HH           |
| 6           | 120-9287-03        | 1           | LH Auger ASM       | 12          | 32144-70           | 4           | Screw-HWHTF        |

# 24 Inch Auger Gearcase Assembly No. 120-3859

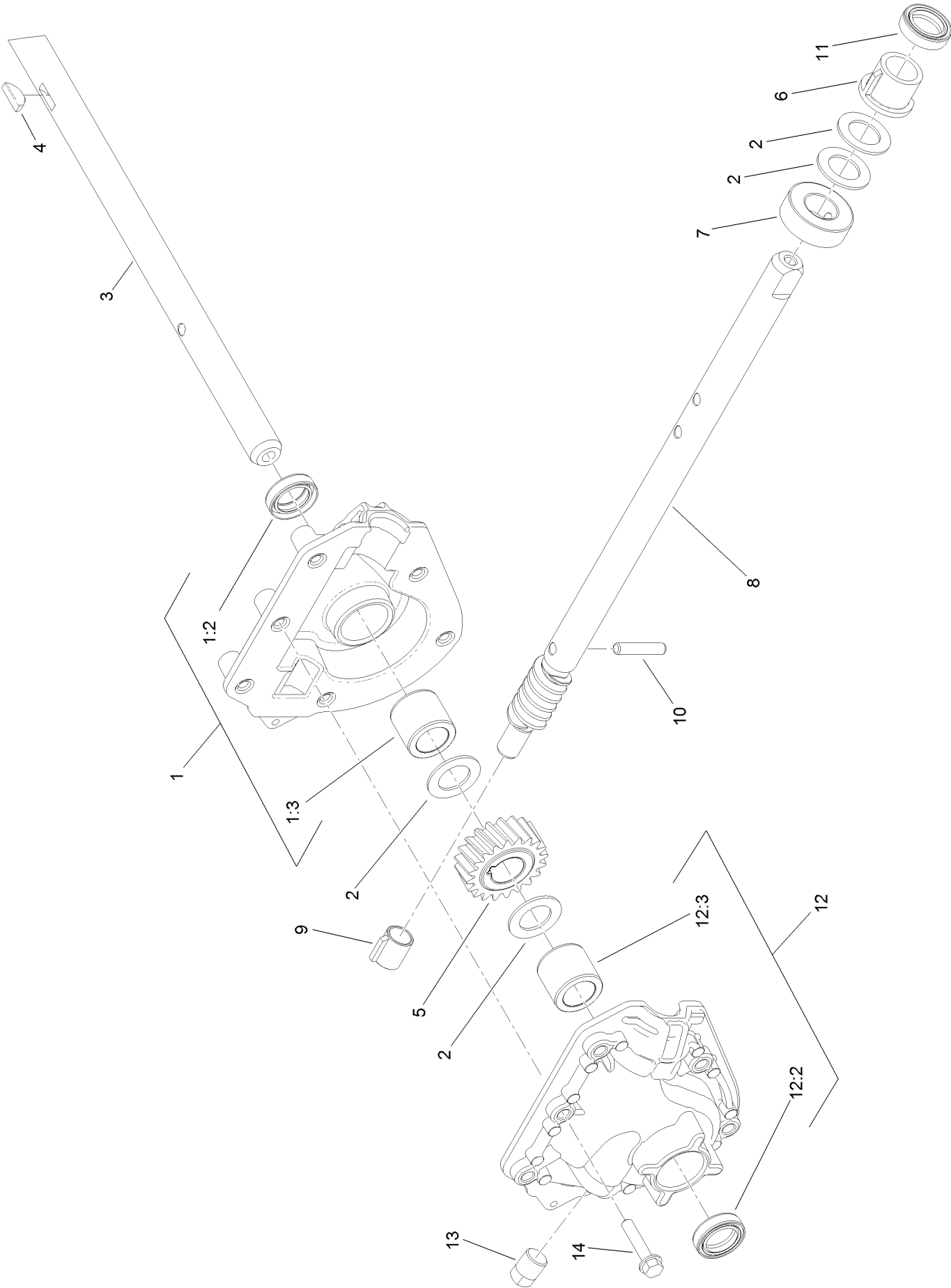

## 24 Inch Auger Gearcase Assembly No. 120-3859 (continued)

| <i>Ref.</i> | <i>Part Number</i> | <i>Qty.</i> | <i>Description</i>     | <i>Ref.</i> | <i>Part Number</i> | <i>Qty.</i> | <i>Description</i>     |
|-------------|--------------------|-------------|------------------------|-------------|--------------------|-------------|------------------------|
| 1           | 121-1209           | 1           | RH Auger Gearcase ASM  | 8           | 121-1234           | 1           | Shaft-Impeller, Rolled |
| 1:2         | 121-6634           | 1           | Seal-Shaft             | 9           | 62-1150            | 1           | Bushing-Worm           |
| 1:3         | 120-9269           | 1           | Bushing-Sleeve         | 10          | 107-8899           | 1           | Pin-Dowel              |
| 2           | 119-7640           | 4           | Washer-Thrust          | 11          | 121-6634           | 1           | Seal-Shaft             |
| 3           | 120-3858           | 1           | Shaft-Output, Auger    | 12          | 121-1210           | 1           | LH Auger Gearcase ASM  |
| 4           | 3257-5             | 1           | Key-Woodruff           | 12:2        | 121-6634           | 1           | Seal-Shaft             |
| 5           | 119-1576           | 1           | Gear-Helical, 20 Tooth | 12:3        | 120-9269           | 1           | Bushing-Sleeve         |
| 6           | 119-7635           | 1           | Bushing-Input          | 13          | 121-6832           | 1           | Plug-Pipe, SQH         |
| 7           | 119-7636           | 1           | Collar-Thrust          | 14          | 108-4862           | 6           | Screw-HWH Thd Roll     |

# Impeller Assembly

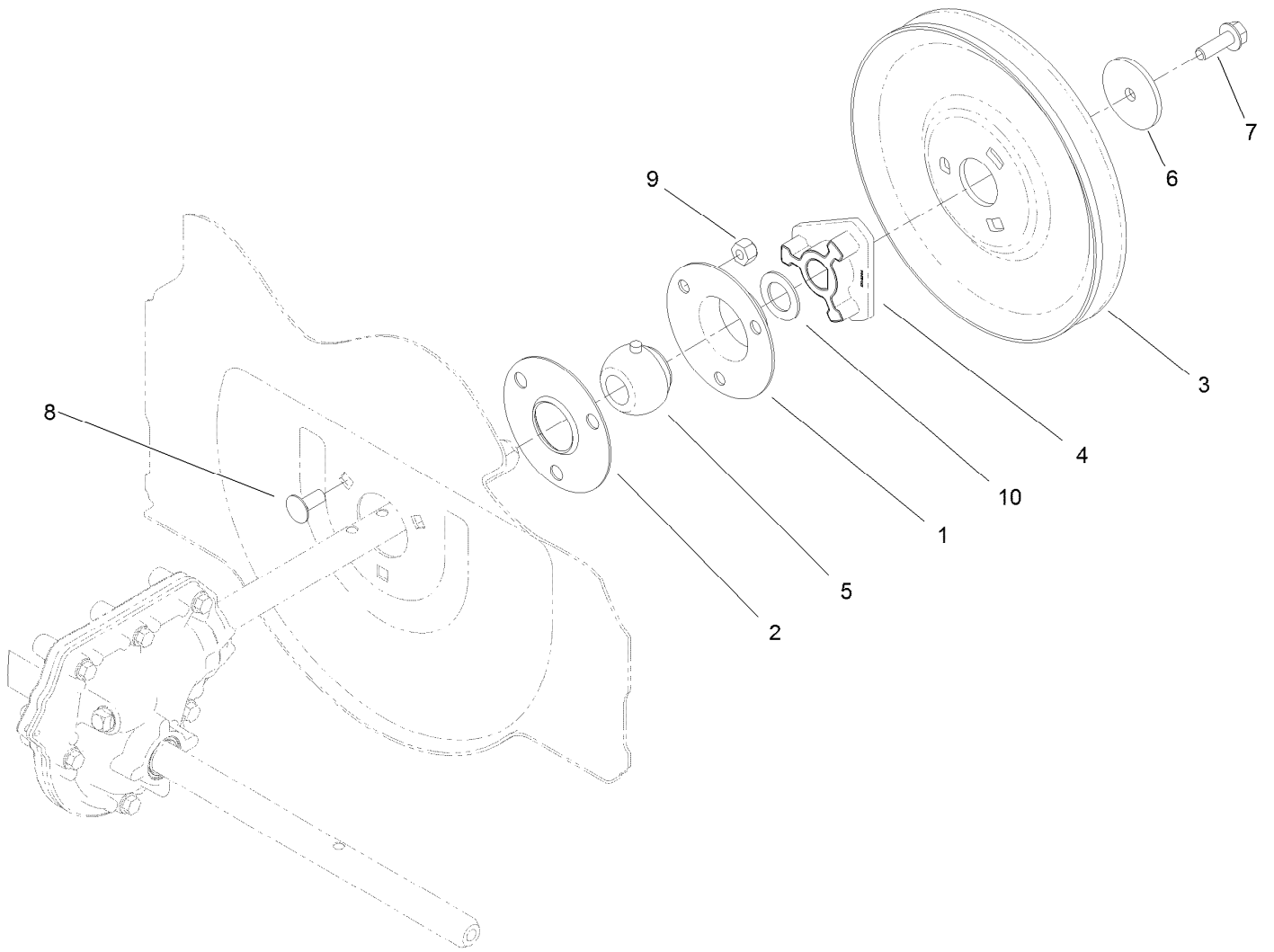



## Impeller Assembly (continued)

| <i>Ref.</i> | <i>Part Number</i> | <i>Qty.</i> | <i>Description</i>   | <i>Ref.</i> | <i>Part Number</i> | <i>Qty.</i> | <i>Description</i> |
|-------------|--------------------|-------------|----------------------|-------------|--------------------|-------------|--------------------|
| 1           | 26-6110            | 1           | Flange-Cup, Bearing  | 6           | 121-1230           | 1           | Washer-Plain       |
| 2           | 26-6120            | 1           | Flange-Cup, Bearing  | 7           | 115-5142           | 1           | Screw-HHF          |
| 3           | 136-7157           | 1           | Pulley-Impeller      | 8           | 3230-23            | 3           | Bolt-CARR          |
| 4           | 120-9264           | 1           | Hub-Impeller, Pulley | 9           | 3296-29            | 3           | Nut-Lock, NI       |
| 5           | 120-9272           | 1           | Bearing              | 10          | 119-7640           | 1           | Washer-Thrust      |

# Powerhead, Pulley and Belt Assembly

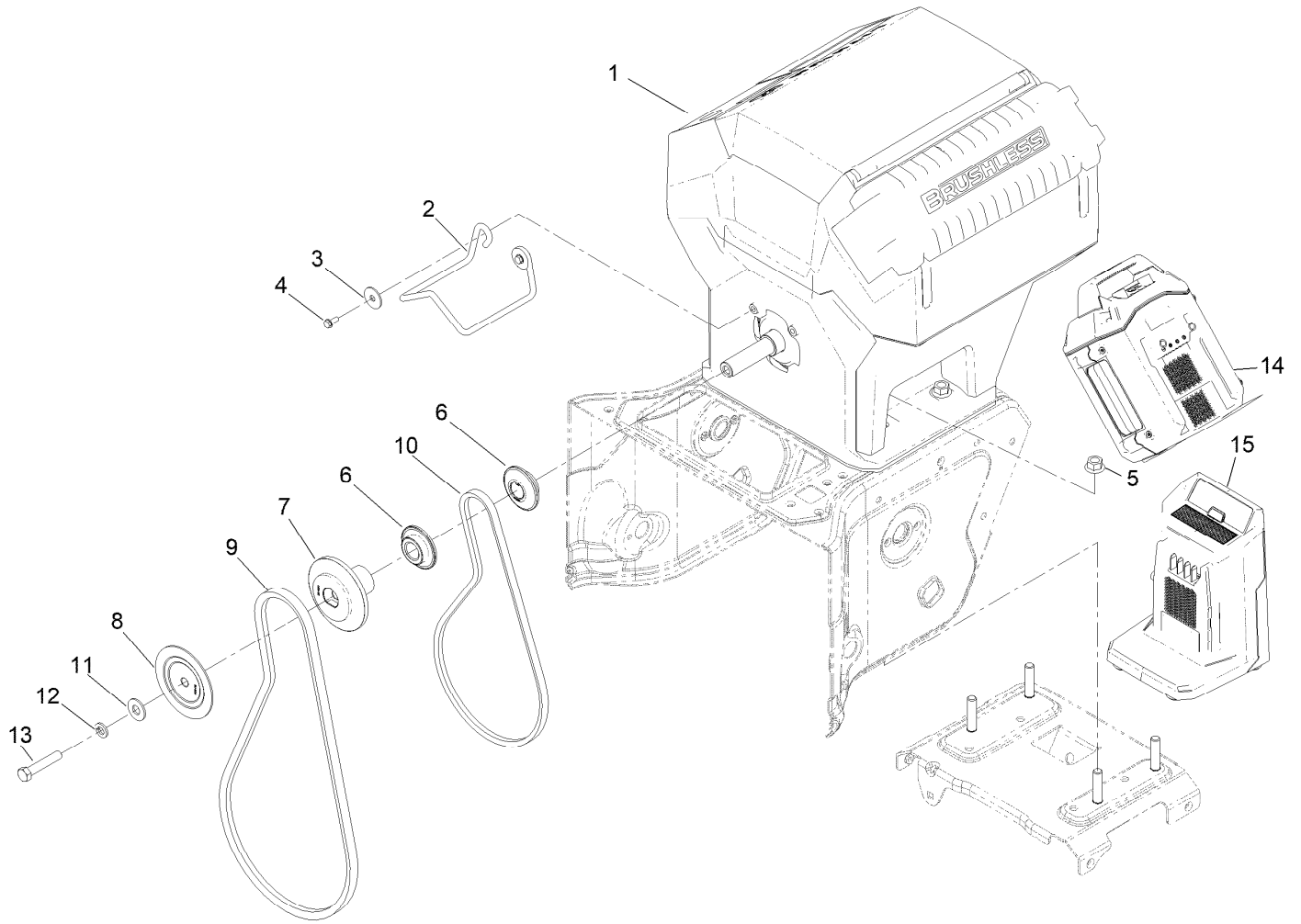

## Powerhead, Pulley and Belt Assembly (continued)

| <i>Ref.</i> | <i>Part Number</i> | <i>Qty.</i> | <i>Description</i>      | <i>Ref.</i> | <i>Part Number</i> | <i>Qty.</i> | <i>Description</i>                          |
|-------------|--------------------|-------------|-------------------------|-------------|--------------------|-------------|---|
| 1           | 139-5315           | 1           | Powerhead-60V           | 9           | 120-3892           | 1           | Belt-V                                      |
| 2           | 139-5299           | 1           | Guide-Belt              | 10          | 120-3893           | 1           | Belt-V                                      |
| 3           | 114-9049           | 2           | Washer-Flat,Fender      | 11          | 3256-4             | 1           | Washer-Flat                                 |
| 4           | 139-1700           | 2           | Screw-HWH, Thd Roll     | 12          | 3253-21            | 1           | Washer-Lock                                 |
| 5           | 136-8683           | 4           | Nut-Lock                | 13          | 120-2302           | 1           | Screw-HH                                    |
| 6           | 137-3400           | 2           | Pulley-Engine, Traction | 14          | 88660              | 2           | Battery-Li-Ion, 60V 6.0Ah,<br>324Wh[3P,Rtl] |
| 7           | 120-9283           | 1           | Pulley-Auger, Rear      | 15          | 88602              | 2           | Charger-Battery, 60V 2 Amp                  |
| 8           | 120-9284           | 1           | Pulley-Auger, Front     |             |                    |             |   |

# 60 Volt Powerhead Assembly No. 139-5315

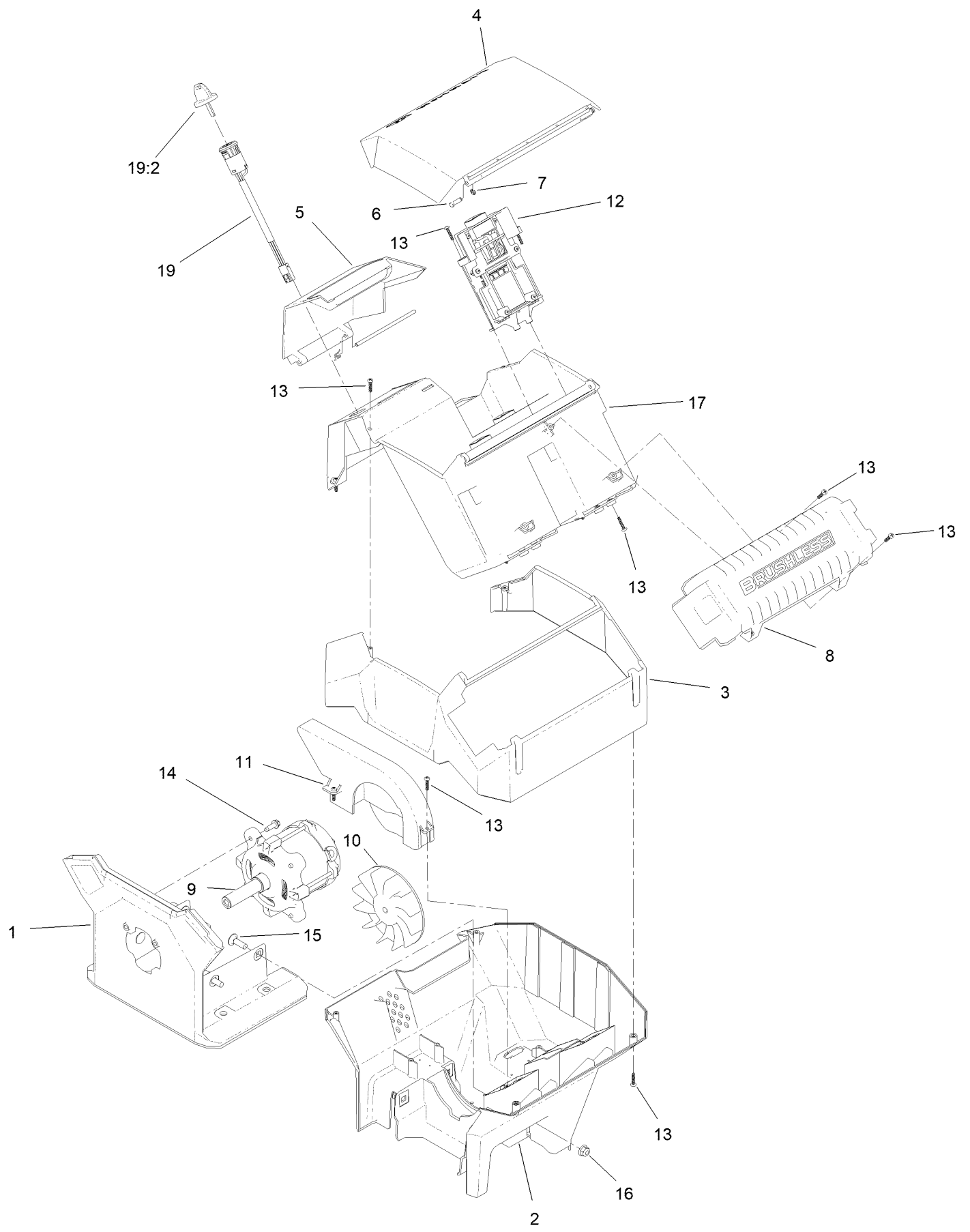

## 60 Volt Powerhead Assembly No. 139-5315 (continued)

| <i>Ref.</i> | <i>Part Number</i> | <i>Qty.</i> | <i>Description</i>                | <i>Ref.</i> | <i>Part Number</i> | <i>Qty.</i> | <i>Description</i>            |
|-------------|--------------------|-------------|-----------------------------------|-------------|--------------------|-------------|-------------------------------|
| 1           | 139-5316           | 1           | Motor Mount                       | 11          | 139-5269           | 1           | Cover-Fan                     |
| 2           | 139-5317           | 1           | Housing-Motor                     | 12          | 137-9435           | 3           | Battery Track Assembly        |
| 3           | 139-5318           | 1           | Cover-Controller                  | 13          | 94-4496            | 27          | Screw-PPH                     |
| 4           | 139-5320           | 1           | Door-Top                          | 14          | 49-2040            | 4           | Screw-HWHTF                   |
| 5           | 139-5321           | 1           | Door-Bottom                       | 15          | 3230-2             | 4           | Bolt-CARR                     |
| 6           | 131-3027           | 4           | Pin-Throttle Cable                | 16          | 104-8300           | 4           | Nut-HF, NI                    |
| 7           | 110-1758           | 4           | Ring-Retaining                    | 17          | 139-5319           | 1           | Bucket-Battery                |
| 8           | 147-9461           | 1           | Motor Controller<br>ASM-Powerhead | 19          | 161-5981           | 1           | Ignition ASM-Powerhead        |
| 9           | 139-5289           | 1           | Motor-60V, 2 Stage                | 19:2        | 147-1755           | 1           | Key-60V 2 Stage Power<br>Head |
| 10          | 139-5322           | 1           | Fan-Fc                            |             |                    |             |                               |

# Chute Assembly

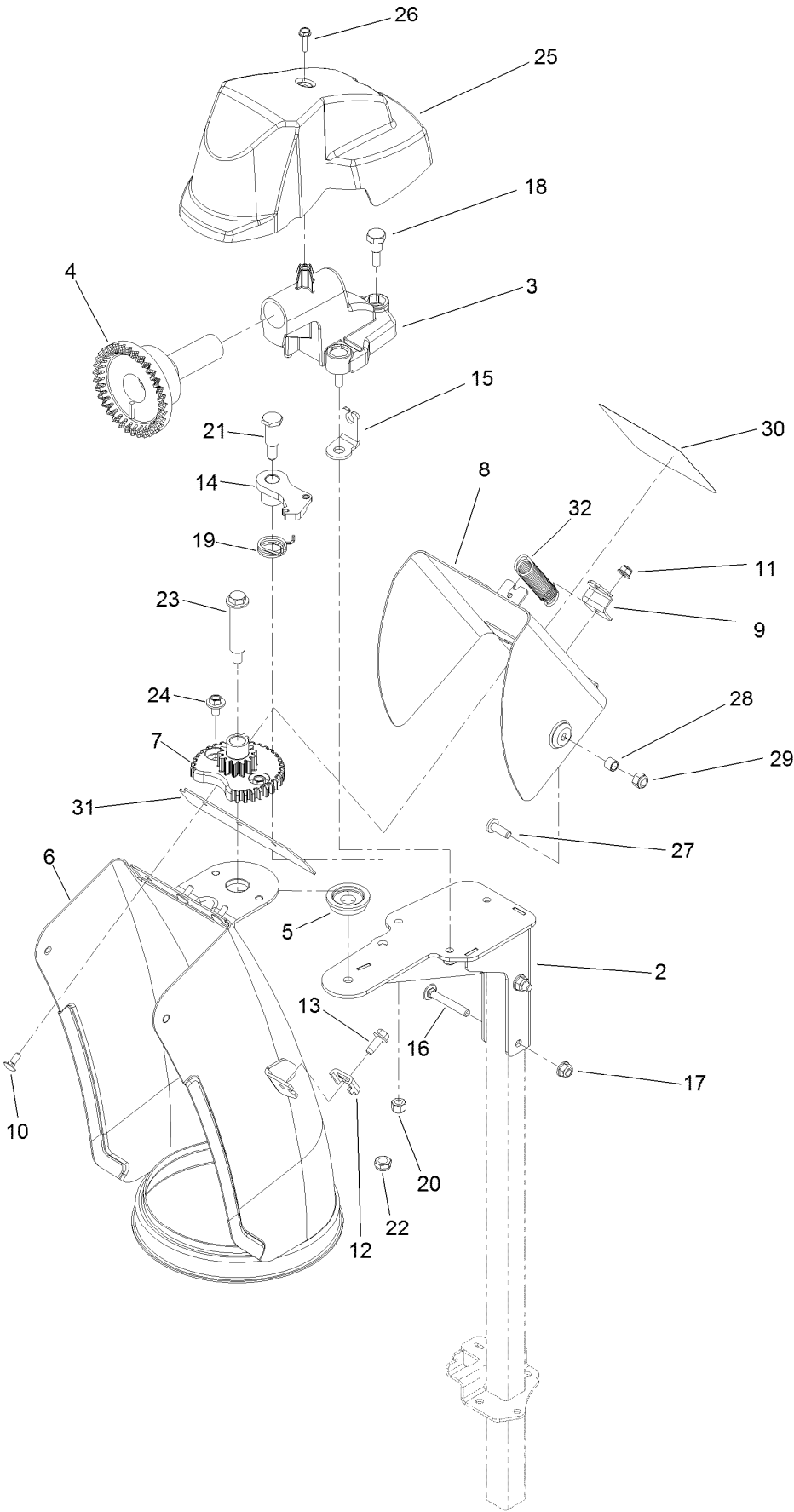

## Chute Assembly (continued)

| <i>Ref.</i> | <i>Part Number</i> | <i>Qty.</i> | <i>Description</i> | <i>Ref.</i> | <i>Part Number</i> | <i>Qty.</i> | <i>Description</i>   |
|-------------|--------------------|-------------|--------------------|-------------|--------------------|-------------|----------------------|
| 2           | 138-3605-03        | 1           | Support-Chute      | 18          | 136-7197           | 3           | Screw-Shoulder       |
| 3           | 138-3606           | 1           | Mount-Gear, Face   | 19          | 108-7315           | 1           | Spring-Torsion       |
| 4           | 106-4471           | 1           | Gear-Face          | 20          | 137-3088           | 3           | Nut-Hex              |
| 5           | 106-4422           | 1           | Spacer-Chute       | 21          | 137-3103           | 1           | Screw-Shoulder, HH   |
| 6           | 138-3611-01        | 1           | Chute              | 22          | 137-3089           | 3           | Nut-Hex              |
| 7           | 106-4472           | 1           | Gear-Chute         | 23          | 136-7199           | 1           | Bolt-Shoulder        |
| 8           | 138-3615-01        | 1           | Deflector          | 24          | 46-6810            | 2           | Screw And Washer ASM |
| 9           | 138-3612-01        | 1           | Bracket-Spring     | 25          | 138-3627           | 1           | Cover-Chute, Gear    |
| 10          | 135-1929           | 3           | Bolt-CARR          | 26          | 98-1375            | 1           | Screw-HWH            |
| 11          | 138-0719           | 3           | Nut-HF             | 27          | 138-0689           | 1           | Screw-PH             |
| 12          | 136-7191           | 1           | Clamp-Cable        | 28          | 138-3678           | 1           | Spacer               |
| 13          | 137-3043           | 1           | Screw-HWH          | 29          | 137-3094           | 1           | Nut-Hex              |
| 14          | 106-4476           | 1           | Latch-Chute        | 30          | 137-6198           | 1           | Decal-Danger         |
| 15          | 138-3607           | 1           | Anchor-Cable       | 31          | 138-3671           | 1           | Gasket-Deflector     |
| 16          | 120-9698           | 2           | Bolt-CARR          | 32          | 138-8493           | 1           | Spring-Chute, Upper  |
| 17          | 119-4040           | 2           | Nut-HF, NI         |             |                    |             |                      |

# Lever Chute Control Assembly

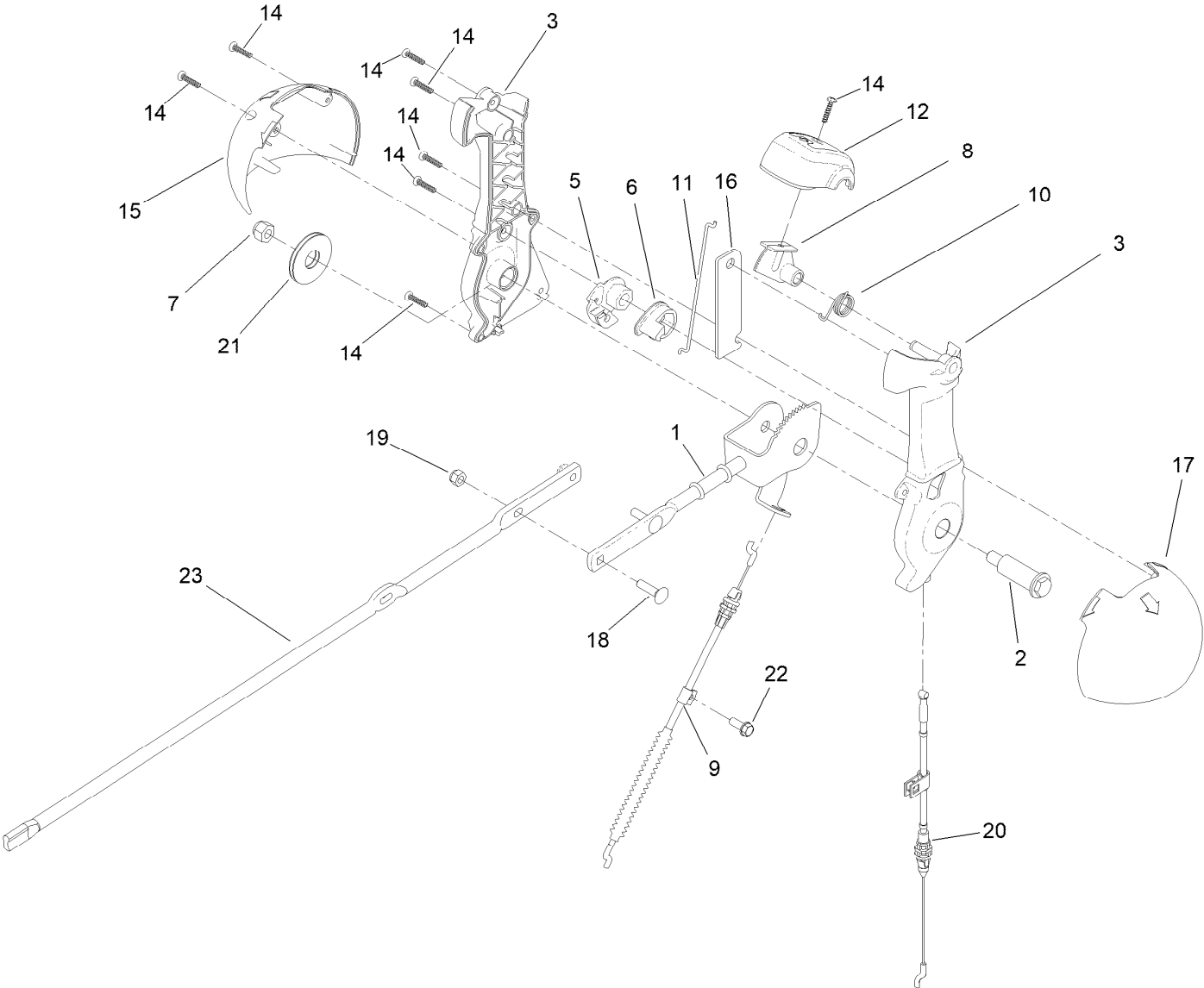



## Lever Chute Control Assembly (continued)

| <i>Ref.</i> | <i>Part Number</i> | <i>Qty.</i> | <i>Description</i>       | <i>Ref.</i> | <i>Part Number</i> | <i>Qty.</i> | <i>Description</i>         |
|-------------|--------------------|-------------|--------------------------|-------------|--------------------|-------------|----------------------------|
| 1           | 138-0662           | 1           | Rod-Control, Chute       | 14          | 94-4496            | 8           | Screw-PPH                  |
| 2           | 138-0659           | 1           | Screw-Shoulder, HWH      | 15          | 136-6677           | 1           | Globe-Quickstick, RH       |
| 3           | 139-1552           | 1           | Chute Control Lever ASM  | 16          | 136-6632           | 1           | Plate-Stiffner             |
| 5           | 105-9988           | 1           | Lever-Cable, Deflector   | 17          | 136-6678           | 1           | Globe-Quickstick, LH       |
| 6           | 106-7310           | 1           | Pawl-Latch               | 18          | 137-3056           | 3           | Bolt-CARR                  |
| 7           | 137-3087           | 1           | Nut-Hex                  | 19          | 137-3094           | 3           | Nut-Hex                    |
| 8           | 137-6238           | 1           | Trigger-Latch            | 20          | 144-1237           | 1           | Cable-Rotation, Chute      |
| 9           | 138-3672           | 1           | Cable-Control, Deflector | 21          | 138-0744           | 1           | Washer-Friction, Composite |
| 10          | 105-9982           | 1           | Spring-Torsion           | 22          | 32144-85           | 1           | Screw-HWH Thd Form         |
| 11          | 138-0688           | 1           | Link-Latch               | 23          | 138-3635           | 1           | Rod-Chute                  |
| 12          | 137-6239           | 1           | Cap-Lever                |             |                    |             |                            |

# Handle Assembly

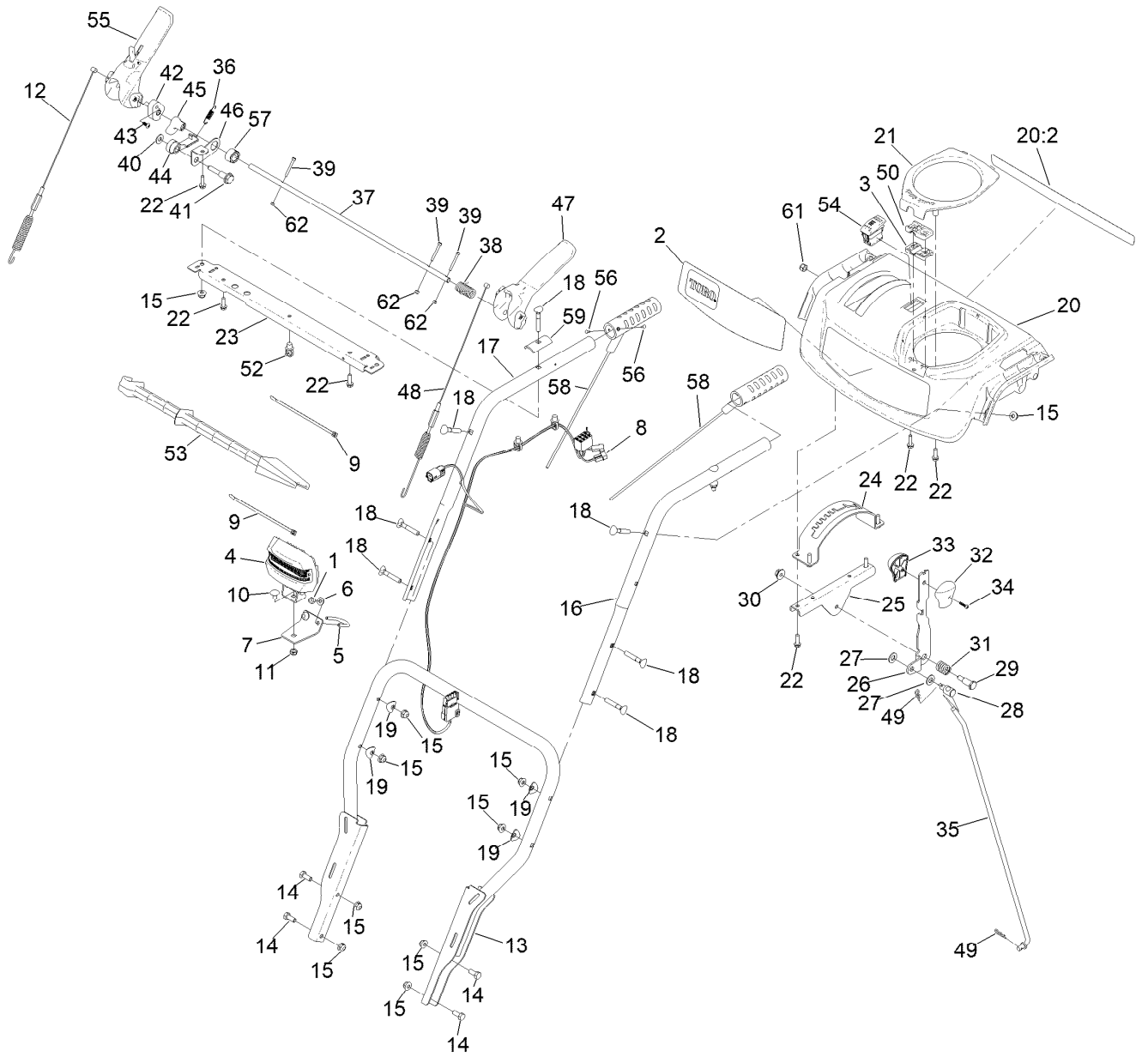

## Handle Assembly (continued)

| <i>Ref.</i> | <i>Part Number</i> | <i>Qty.</i> | <i>Description</i>      | <i>Ref.</i> | <i>Part Number</i> | <i>Qty.</i> | <i>Description</i>               |
|-------------|--------------------|-------------|-------------------------|-------------|--------------------|-------------|----------------------------------|
| 1           | 137-3094           | 2           | Nut-Hex                 | 31          | 136-7121           | 1           | Spring-Compression               |
| 2           | 145-0888           | 1           | Decal - Console         | 32          | 105-9999           | 1           | Knob-Shift, LH                   |
| 3           | 139-3587           | 1           | Support-Rod, Lower      | 33          | 106-4423           | 1           | Knob-Shift, RH                   |
| 4           | 138-0670           | 1           | LED Light ASM           | 34          | 94-4496            | 1           | Screw-PPH                        |
| 5           | 136-7120           | 1           | Clamp-Light             | 35          | 144-1239           | 1           | Rod-Shift                        |
| 6           | 137-3072           | 2           | Washer-Flat             | 36          | 136-7161           | 1           | Spring-Lockout, Handle           |
| 7           | 127-5961-03        | 1           | Bracket-Light           | 37          | 137-6182           | 1           | Rod-Lockout                      |
| 8           | 145-0898           | 1           | Harness-Wire, LED Light | 38          | 138-0678           | 1           | Spring-Torsion, Handle<br>Return |
| 9           | 614249             | 3           | Tie-Cable               | 39          | 145-0660           | 3           | Screw-HSH,Spl                    |
| 10          | 3230-19            | 1           | Bolt-CARR               | 40          | 98-3499            | 1           | Washer-Flat                      |
| 11          | 137-3089           | 1           | Nut-Hex                 | 41          | 138-0681           | 1           | Screw-Shoulder                   |
| 12          | 121-6812           | 1           | Cable-Auger             | 42          | 144-0320           | 1           | Handle Lock                      |
| 13          | 139-3574-03        | 1           | Handle-Lower, Weld ASM  | 43          | 137-9137           | 1           | Screw-PPH                        |
| 14          | 137-3052           | 4           | Screw-HH                | 44          | 144-0321           | 1           | Latch, Lockout                   |
| 15          | 138-8401           | 12          | Nut-HF                  | 45          | 138-8466           | 1           | Cam-Lockout                      |
| 16          | 137-6206-03        | 1           | Handle-Upper, LH        | 46          | 138-3652           | 1           | Link-Lockout                     |
| 17          | 137-6207-03        | 1           | Handle-Upper, RH        | 47          | 137-6171           | 1           | Lever-Control                    |
| 18          | 137-3107           | 8           | Screw-Handle            | 48          | 144-0323           | 1           | Cable-Traction                   |
| 19          | 137-3009           | 4           | Washer-Cup              | 49          | 137-3083           | 2           | Pin-Hair                         |
| 20          | 145-0665           | 1           | Control Panel Assembly  | 50          | 139-3588           | 1           | Support-Rod, Upper               |
| 20:2        | 137-6249           | 1           | Decal-Safety            | 52          | 32180-030          | 1           | Clip-Tie                         |
| 21          | 137-6178           | 1           | Cover-Quickstick        | 53          | 110-3408           | 1           | Stick-Cleanout                   |
| 22          | 137-3099           | 8           | Screw-Plastite, HWH     | 54          | 99-7420            | 1           | Plug-Hole                        |
| 23          | 145-4075-01        | 1           | Brace-Console           | 55          | 145-0871           | 1           | Auger Control ASM                |
| 24          | 137-6187-03        | 1           | Gate-Shift              | 56          | 3290-271           | 4           | Rivet-Pop                        |
| 25          | 137-6188-03        | 1           | Bracket-Shift           | 57          | 138-8467           | 1           | Collar-Cam                       |
| 26          | 144-2827-03        | 1           | Selector-Speed          | 58          | 120-1333           | 1           | Grip-Handle                      |
| 27          | 115-1166           | 2           | Washer-Plain            | 59          | 145-0872-03        | 1           | Handle Saddle                    |
| 28          | 136-7193           | 1           | Trunnion-Rod            | 61          | 137-3093           | 1           | Nut-Hex                          |
| 29          | 137-3103           | 1           | Screw-Shoulder, HH      | 62          | 140-3749           | 3           | Nut-Lock Rohs                    |
| 30          | 137-3038           | 1           | Nut-HF                  |             |                    |             |                                  |

# Attachments and Accessories

## For 39924 Power Max e24 60V Snowthrower

| <b>Product Name</b>                                | <b>Model/Part</b> |
|--|-------------------|
| Weight Kit .....                                   | 107-3815          |
| Snow Cab Kit.....                                  | 127-5960          |
| Non-Marking Skid Kit.....                          | 38211             |
| Heavy-Duty Skid Kit.....                           | 38212             |
| Drift Breaker Kit .....                            | 38213             |
| Toro Snow Oil 0W30 Synthetic 20-Ounce Bottle ..... | 38913             |
| Toro 2-Stage Cover.....                            | 490-7466          |
| Plain 2-Stage Cover.....                           | 490-7467          |

**Notes:**

**Notes:**

**Notes:**



**Count on it.**