



Count on it.

Parts Catalog

**Power Max[®] e26 60V
Snowthrower**

Model No. 39926—Serial No. 400000000 and Up



Ordering Replacement Parts

To order replacement parts, please supply the part number, the quantity, and the description of each part desired.

Understanding Reference Numbers

Each identified part in an illustration has a reference number. The reference number for a part also appears in the parts list, along with other information about the part.

This catalog uses two special reference number formats, one to indicate parts in a service assembly and another to indicate the quantity of a given part in an illustration.

Service Assembly Reference Numbers

Parts in service assemblies have reference numbers in the form a:b. The a represents the reference number of the entire service assembly and the b represents a sequential number unique to each part within the service assembly.

For example, a wheel assembly might be identified by reference number 6, the tire by 6:1, the valve by 6:2, and the wheel by 6:3. When you order the assembly identified by reference number 6, you receive all parts identified by reference numbers 6:1, 6:2, and 6:3. However, you may also order any part individually. Reference numbers of this type appear in illustration and in parts lists.

Reference Numbers Indicating Quantity

In an illustration, if a reference number indicates more than one part, the reference number has the form nX y. The n represents the quantity of the part, the X is the multiplication symbol, and the y represents the reference number.

For example, in an illustration, the reference number 2X 37 means that two of the parts identified by reference number 37 are indicated.

Contents

Main Frame and Auger Housing Assembly	4
Pulley and Bellcrank Assembly	6
Impeller Drive Assembly	8
Drive Assembly	10
Transmission Assembly	12
Gearbox, Auger and Impeller Assembly	14
26 Inch Auger Gearcase Assembly No. 119-7641	16
Impeller Assembly	18
Powerhead, Pulley and Belt Assembly	20
60 Volt Powerhead Assembly No. 139-5315	22
Chute Assembly	24
Chute Control Assembly	26
Handle Assembly	28
Attachments and Accessories	30

Main Frame and Auger Housing Assembly

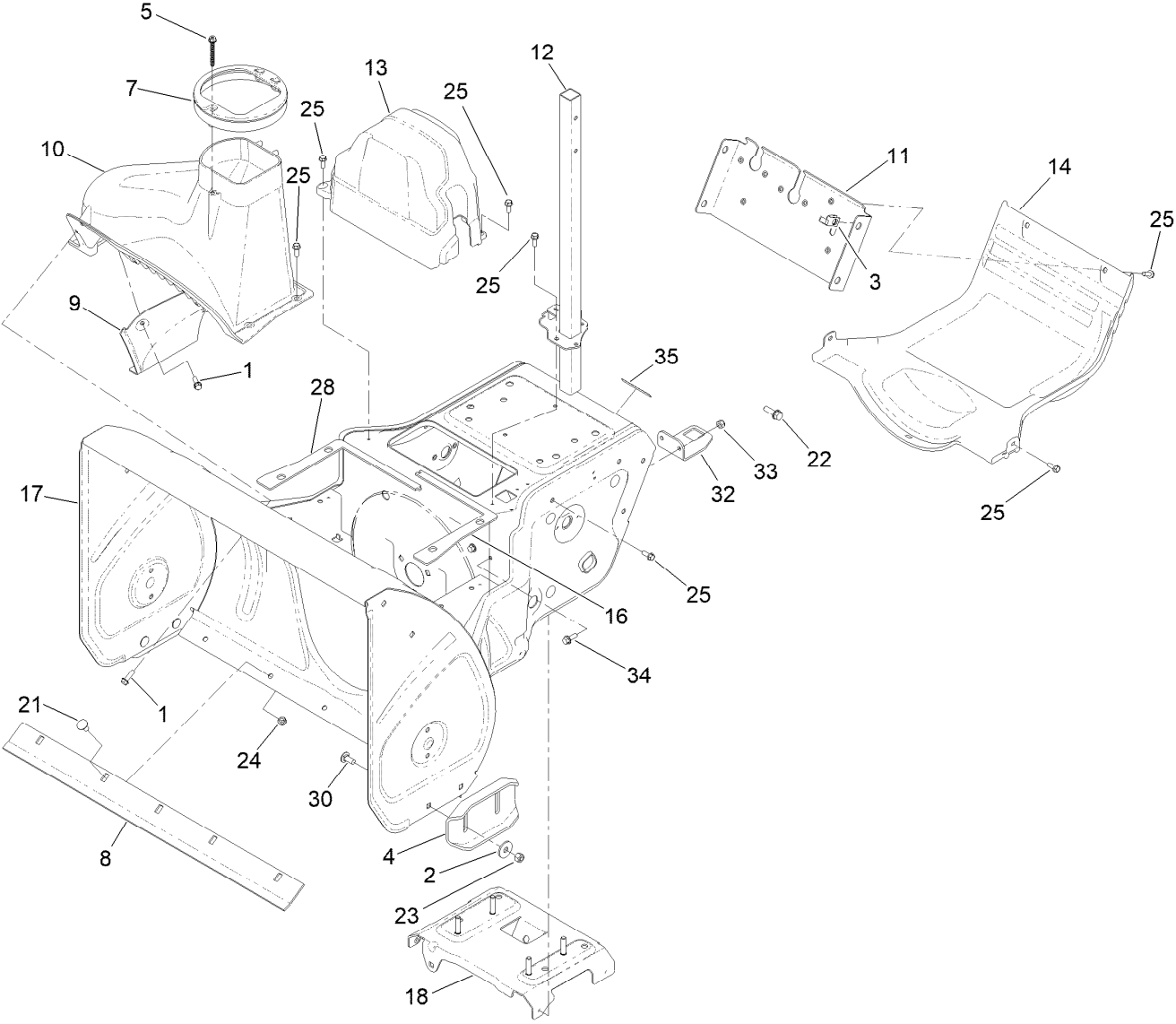

Main Frame and Auger Housing Assembly (continued)

<i>Ref.</i>	<i>Part Number</i>	<i>Qty.</i>	<i>Description</i>	<i>Ref.</i>	<i>Part Number</i>	<i>Qty.</i>	<i>Description</i>
1	46-8091	6	Screw-HWH	17	147-9471	1	Frame ASM
2	52-2861	4	Washer	18	139-5270	1	Brace-Frame
3	94-2413	4	Nut-U	21	3230-18	5	Screw-CARR
4	106-4588-01	2	Skid	22	3234-29	4	Screw-HHF
5	114-3751	1	Screw-HWH, Plastite	23	3296-29	4	Nut-Lock, NI
7	138-3608	1	Guide-Chute	24	3296-47	5	Nut-Lock,NI
8	120-3872-01	1	Scraper-26 Inch	25	32144-85	17	Screw-HWH Thd Form
9	120-7158-01	1	Cover-Liner	28	121-6841	1	Seal-Housing, RH
10	120-7159	1	Cover	30	3230-23	4	Bolt-CARR
11	120-7161-01	1	Brace-Frame	32	137-3410-03	1	Bracket-Post, Chute
12	137-3412-03	1	Support-Chute	33	120-9678	2	Screw-HHF
13	120-7177	1	Cover-Belt	34	137-3094	2	Nut-Hex
14	120-7178	1	Cover-Lower	35	133-8061	1	Decal-Warning
16	120-7181	1	Seal-Housing, LH				

Pulley and Bellcrank Assembly



Pulley and Bellcrank Assembly (continued)

<i>Ref.</i>	<i>Part Number</i>	<i>Qty.</i>	<i>Description</i>	<i>Ref.</i>	<i>Part Number</i>	<i>Qty.</i>	<i>Description</i>
1	3-4244	1	Pulley-Idler	15	120-7165-03	1	Bracket-Bellcrank
2	92-9698	1	Screw-Shoulder	16	136-7155	1	Link-Drive
3	38-7820	2	Bearing-Ball	17	120-9271	2	Bracket-Anchor, Spring
4	25-5640	1	Washer	18	136-7159	1	Arm-Idler, Traction
5	117-7711	1	Bushing-Idler	19	120-9275	1	Spring-Extension
6	119-7645	1	Plate-Wheel, Friction	20	256-257	2	Bushing-Nyliner
7	136-7152	1	Traction Pulley ASM	21	323-29	1	Screw-HH
8	136-7124	1	Retainer-Bearing	22	3230-10	1	Bolt-CARR
9	119-7670-03	1	Bellcrank-Drive	23	3296-29	1	Nut-Lock, NI
10	136-7153	1	Spring-Extension	24	3296-59	1	Nut-Lock, NI
11	119-7679	1	Bracket-Plate, Traction	25	3296-73	1	Nut-Lock, NI
12	120-3883	1	Spring-Extension	26	32144-85	7	Screw-HWH Thd Form
13	137-3435	1	Spring-Extension	27	104-8301	1	Nut-HF, NI
14	120-7156	2	Bushing-Plate, Traction	28	3256-24	1	Washer-Plain

Impeller Drive Assembly

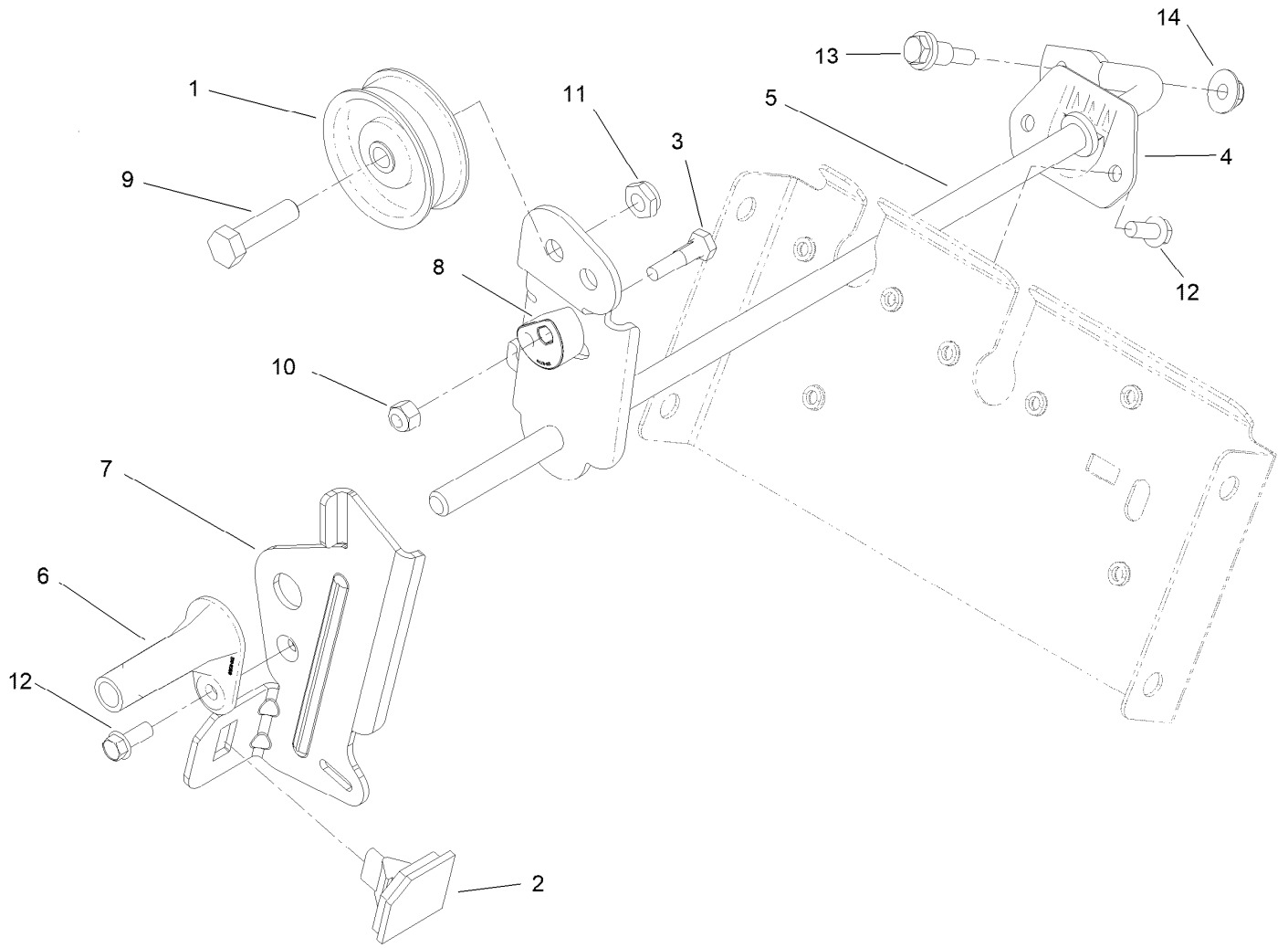

Impeller Drive Assembly (continued)

<i>Ref.</i>	<i>Part Number</i>	<i>Qty.</i>	<i>Description</i>	<i>Ref.</i>	<i>Part Number</i>	<i>Qty.</i>	<i>Description</i>
1	3-4244	1	Pulley-Idler	8	120-9276	1	Eccentric-Brake, Impeller
2	66-8060	1	Pad-Brake	9	323-29	1	Screw-HH
3	136-8674	1	Bolt-Pivot, Eccentric	10	3296-42	1	Nut-Lock, NI
4	120-7167	1	Bushing-Rod, Clutch	11	3296-59	1	Nut-Lock, NI
5	120-9254-03	1	Impeller Clutch ASM	12	32144-85	3	Screw-HWH Thd Form
6	120-9256	1	Pivot-Brake, Impeller	13	104-0858	1	Bolt-Shoulder
7	120-9257-03	1	Arm-Brake, Impeller	14	137-3016	1	Nut-HF

Drive Assembly

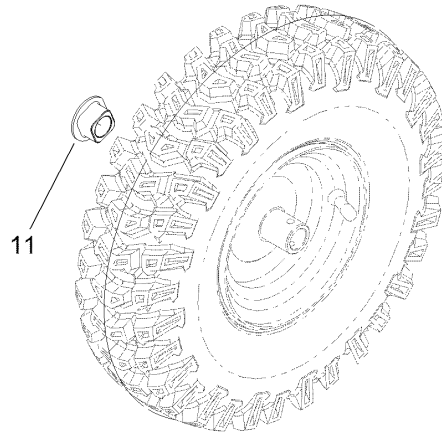
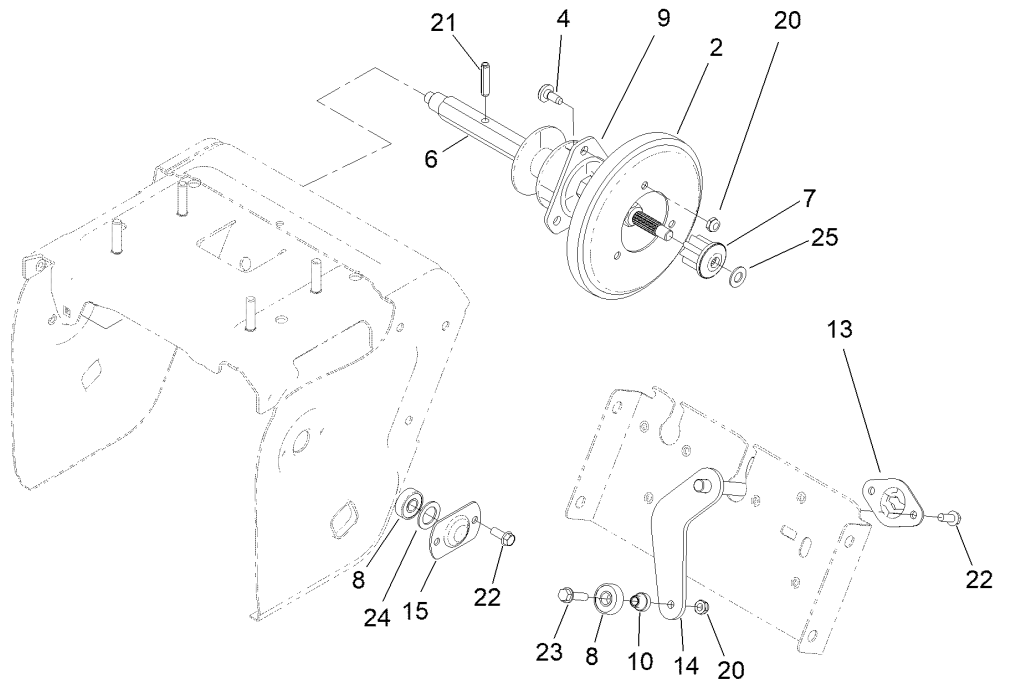
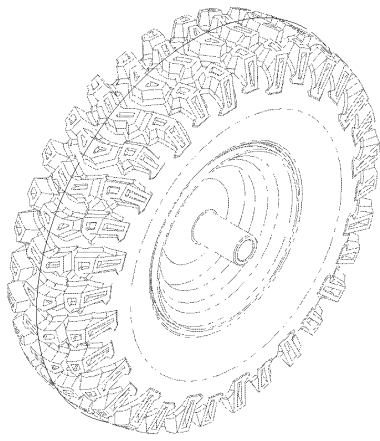

Drive Assembly (continued)

<i>Ref.</i>	<i>Part Number</i>	<i>Qty.</i>	<i>Description</i>	<i>Ref.</i>	<i>Part Number</i>	<i>Qty.</i>	<i>Description</i>
2	119-1567	1	Wheel-Friction	14	120-7193-03	1	Shift Plate ASM
4	120-7950	3	Screw-Torx	15	136-7158	2	Retainer-Bearing
6	140-3745	1	Shaft-Hex	20	3296-56	4	Nut-Lock, NI
7	119-7616	1	Gear-Pinion, 8 Tooth	21	32121-9	1	Pin-Roll, Slotted
8	121-6835	3	Bearing-Ball	22	32144-85	6	Screw-HWH Thd Form
9	119-7630	1	Trunnion	23	32144-86	1	Screw-HWHTF
10	119-7684	1	Spacer-Plate, Shift	24	121-6840	2	Washer-Rubber
11	120-7162	2	Bushing-Axle	25	145-0743	1	Washer-Flat
13	120-7191	1	Retainer-Plate, Shift				

Transmission Assembly

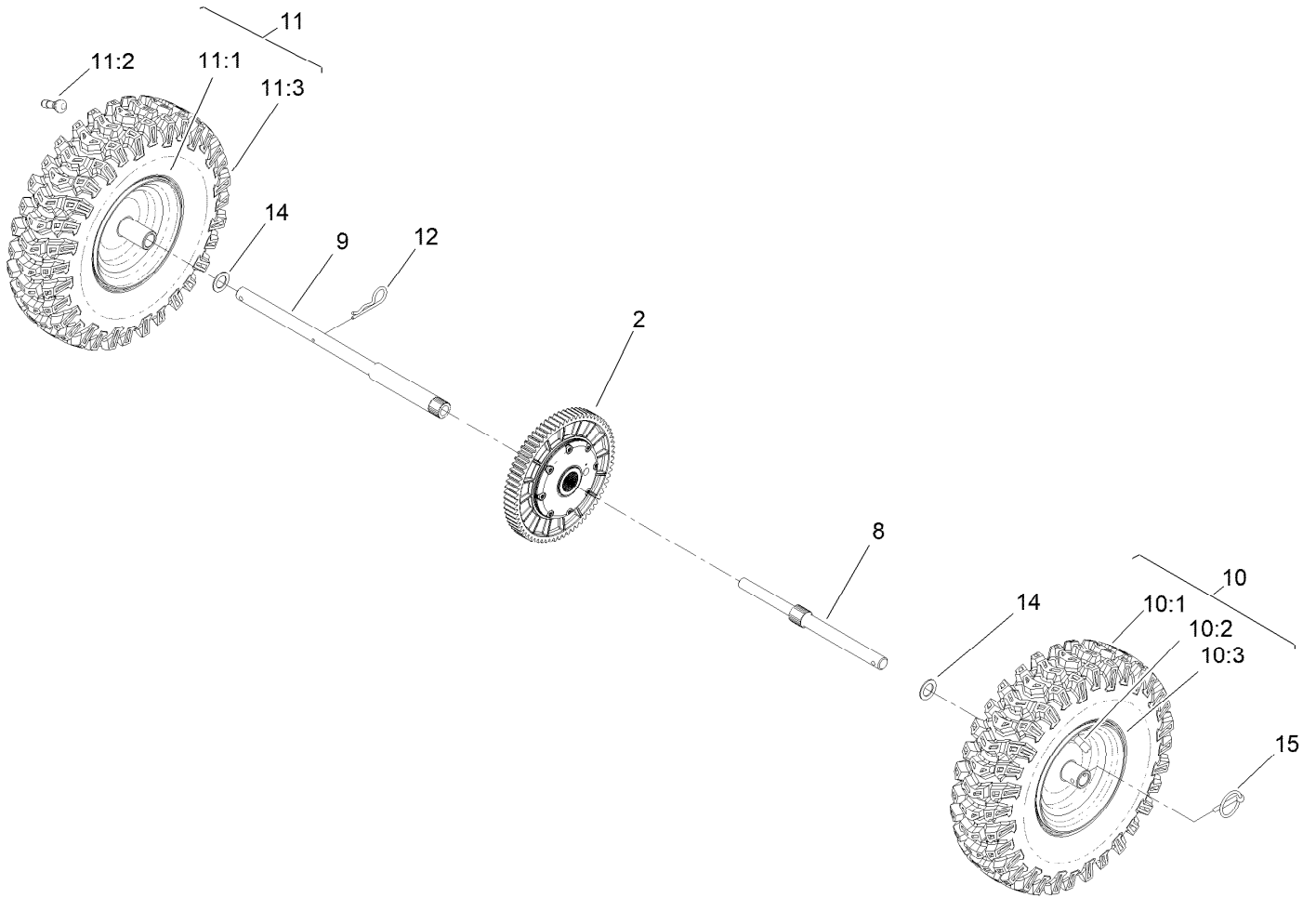

Transmission Assembly (continued)

<i>Ref.</i>	<i>Part Number</i>	<i>Qty.</i>	<i>Description</i>	<i>Ref.</i>	<i>Part Number</i>	<i>Qty.</i>	<i>Description</i>
2	140-3747	1	Transmission-Gt, Di200	11	138-3659	1	RH Wheel And Tire ASM
8	140-3746	1	Axle-Lt, Cts	11:1	138-3669	1	Wheel (15X4 Tire)
9	140-3742	1	Axle-Rt, Cts	11:2	232-27	1	Stem-Valve
10	138-3660	1	LH Wheel And Tire ASM	11:3	138-3668	1	Tire
10:1	138-3669	1	Wheel (15X4 Tire)	12	3290-343	1	Pin-Hair
10:2	232-27	1	Stem-Valve	14	3-8664	2	Washer-Thrust
10:3	138-3668	1	Tire	15	107-3039	2	Pin-Lynch

Gearbox, Auger and Impeller Assembly

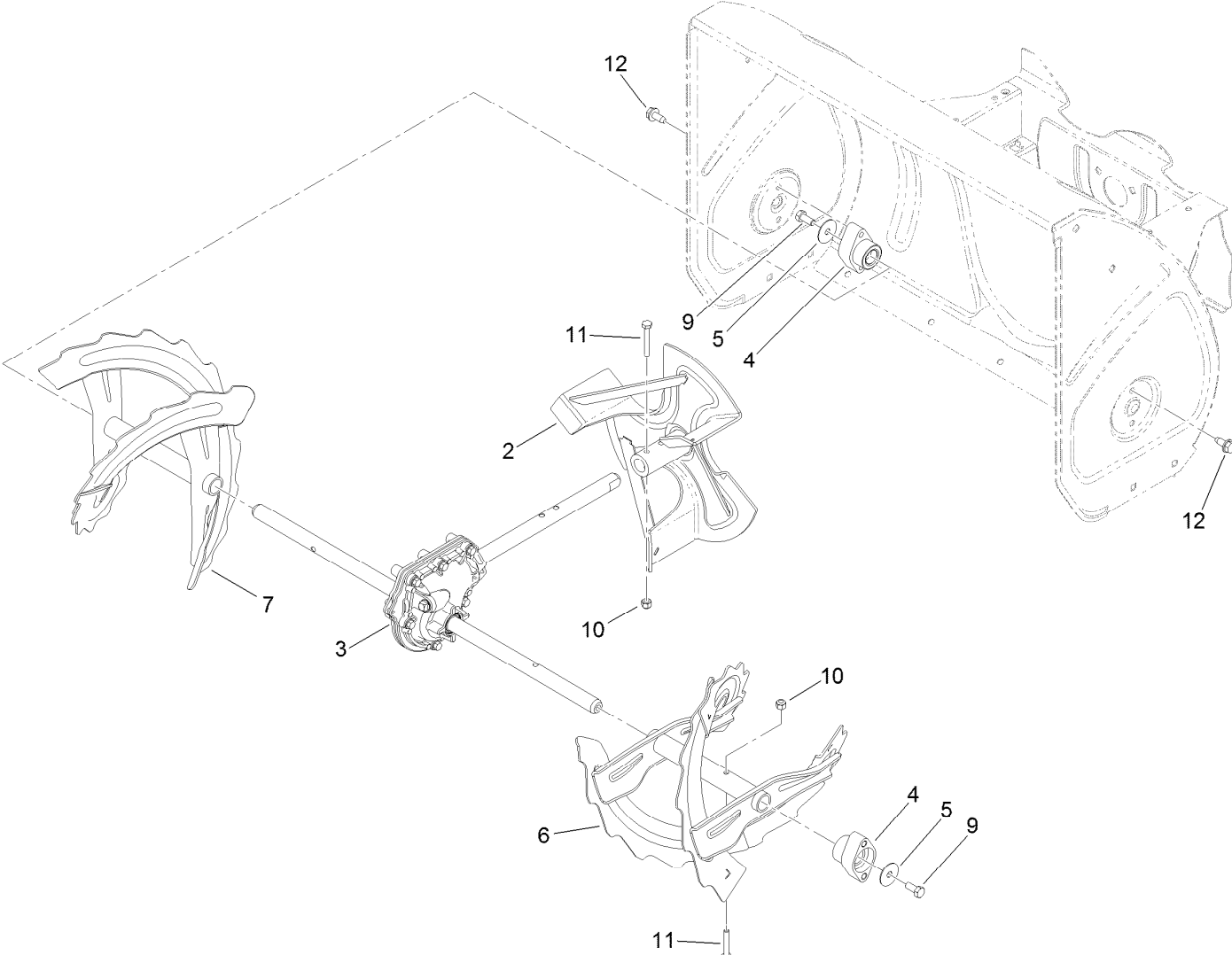

Gearbox, Auger and Impeller Assembly (continued)

<i>Ref.</i>	<i>Part Number</i>	<i>Qty.</i>	<i>Description</i>	<i>Ref.</i>	<i>Part Number</i>	<i>Qty.</i>	<i>Description</i>
2	119-7612-03	1	Impeller ASM	7	120-9290-03	1	RH Auger ASM
3	119-7641	1	Gearcase ASM	9	322-3	2	Screw-HH
4	120-3860	2	Bearing-Augur	10	3296-42	4	Nut-Lock, NI
5	120-3862	2	Washer-Thrust	11	321-10	4	Screw-HH
6	120-9287-03	1	LH Auger ASM	12	32144-70	4	Screw-HWHTF

26 Inch Auger Gearcase Assembly No. 119-7641

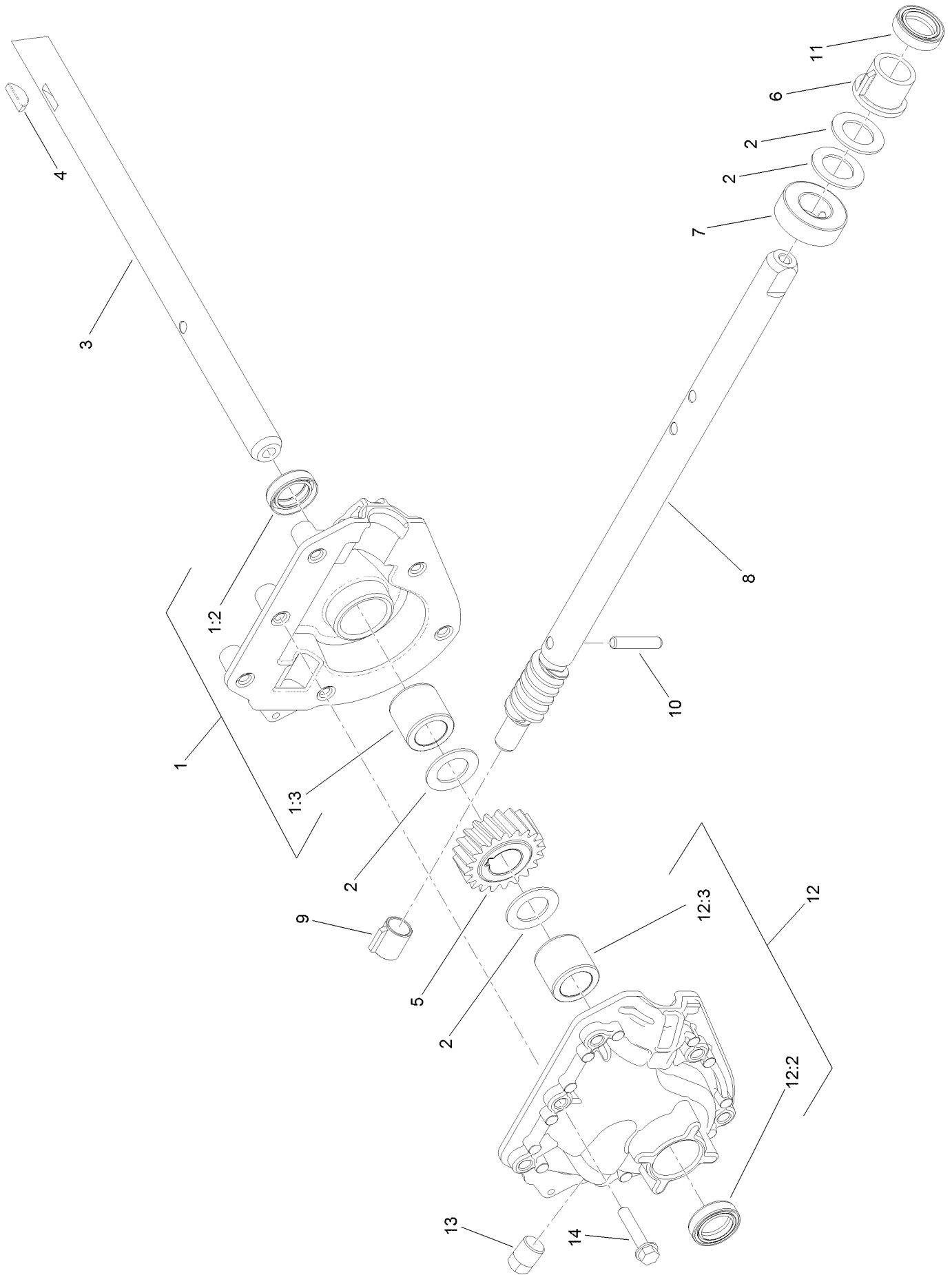

26 Inch Auger Gearcase Assembly No. 119-7641 (continued)

<i>Ref.</i>	<i>Part Number</i>	<i>Qty.</i>	<i>Description</i>	<i>Ref.</i>	<i>Part Number</i>	<i>Qty.</i>	<i>Description</i>
1	121-1209	1	RH Auger Gearcase ASM	8	121-1234	1	Shaft-Impeller, Rolled
1:2	121-6634	1	Seal-Shaft	9	62-1150	1	Bushing-Worm
1:3	120-9269	1	Bushing-Sleeve	10	107-8899	1	Pin-Dowel
2	119-7640	4	Washer-Thrust	11	121-6634	1	Seal-Shaft
3	119-7639	1	Shaft-Output, Auger	12	121-1210	1	LH Auger Gearcase ASM
4	3257-5	1	Key-Woodruff	12:2	121-6634	1	Seal-Shaft
5	119-1576	1	Gear-Helical, 20 Tooth	12:3	120-9269	1	Bushing-Sleeve
6	119-7635	1	Bushing-Input	13	121-6832	1	Plug-Pipe, SQH
7	119-7636	1	Collar-Thrust	14	108-4862	6	Screw-HWH Thd Roll

Impeller Assembly

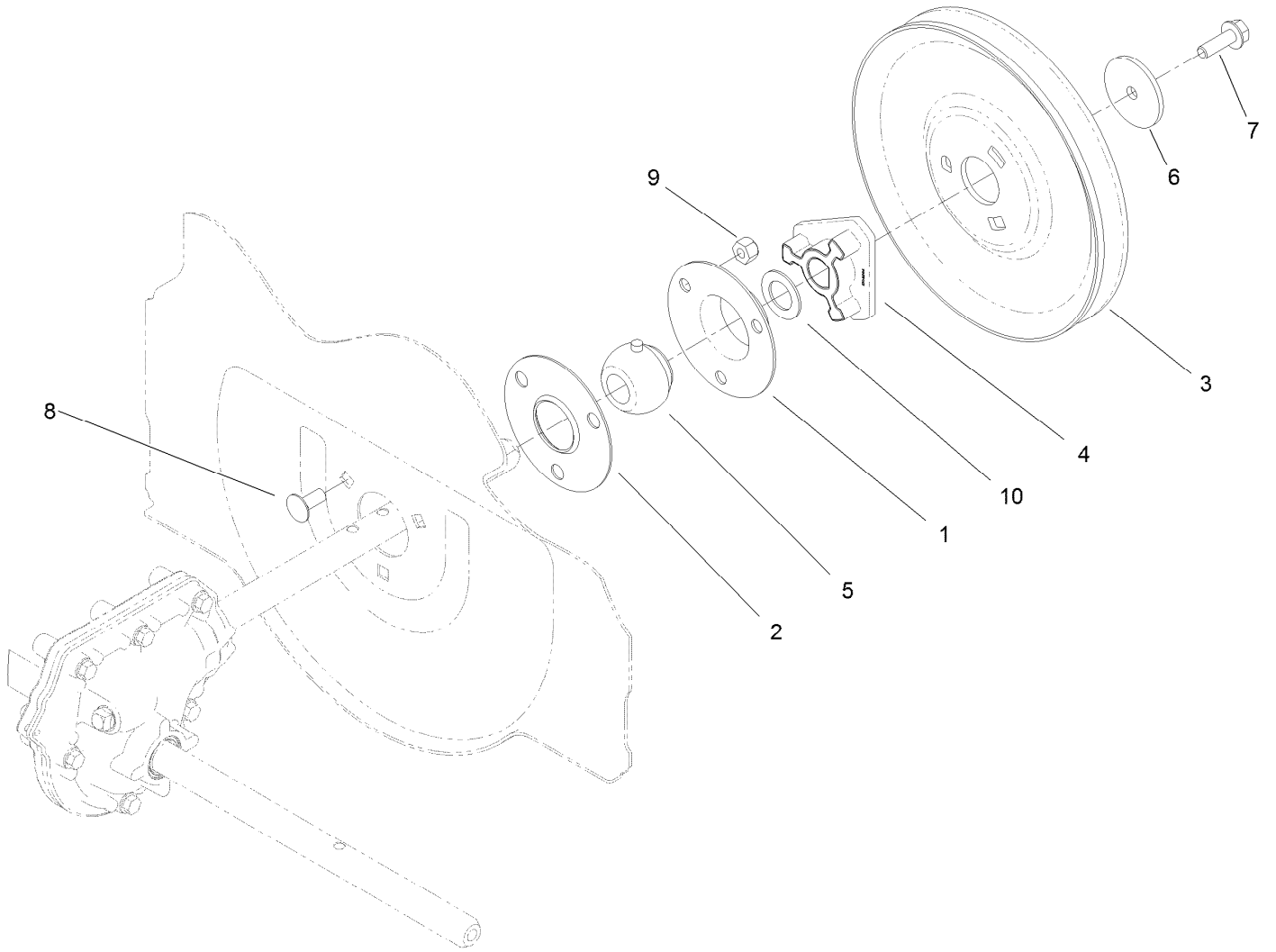

Impeller Assembly (continued)

<i>Ref.</i>	<i>Part Number</i>	<i>Qty.</i>	<i>Description</i>	<i>Ref.</i>	<i>Part Number</i>	<i>Qty.</i>	<i>Description</i>
1	26-6110	1	Flange-Cup, Bearing	6	121-1230	1	Washer-Plain
2	26-6120	1	Flange-Cup, Bearing	7	115-5142	1	Screw-HHF
3	136-7157	1	Pulley-Impeller	8	3230-23	3	Bolt-CARR
4	120-9264	1	Hub-Impeller, Pulley	9	3296-29	3	Nut-Lock, NI
5	120-9272	1	Bearing	10	119-7640	1	Washer-Thrust

Powerhead, Pulley and Belt Assembly

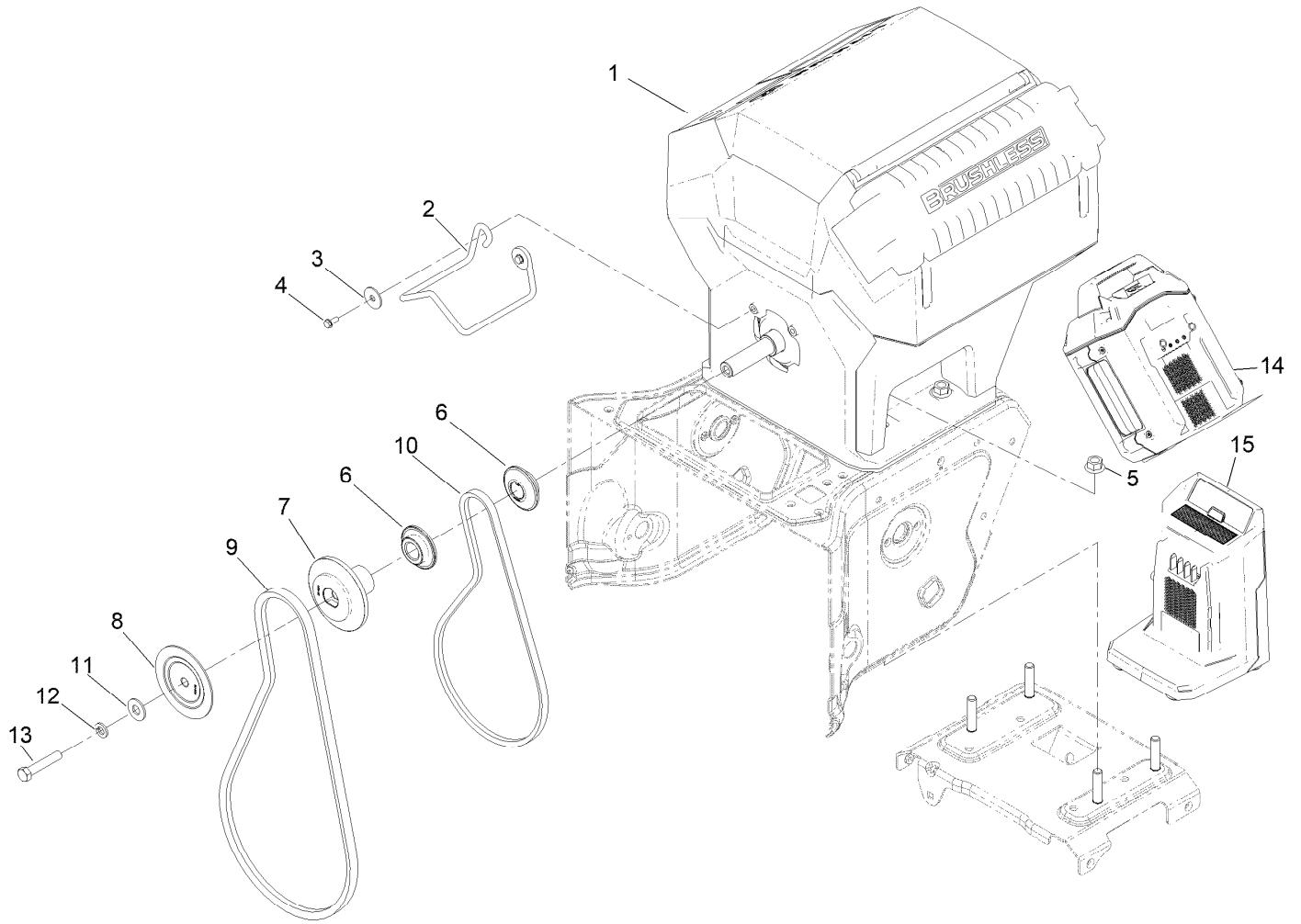

Powerhead, Pulley and Belt Assembly (continued)

<i>Ref.</i>	<i>Part Number</i>	<i>Qty.</i>	<i>Description</i>	<i>Ref.</i>	<i>Part Number</i>	<i>Qty.</i>	<i>Description</i>
1	139-5315	1	Powerhead-60V	9	120-3892	1	Belt-V
2	139-5299	1	Guide-Belt	10	120-3893	1	Belt-V
3	114-9049	2	Washer-Flat,Fender	11	3256-4	1	Washer-Flat
4	139-1700	2	Screw-HWH, Thd Roll	12	3253-21	1	Washer-Lock
5	136-8683	4	Nut-Lock	13	120-2302	1	Screw-HH
6	137-3400	2	Pulley-Engine, Traction	14	88675	2	Battery-Li-Ion, 60V 7.5Ah, 405Wh
7	120-9283	1	Pulley-Auger, Rear	15	88602	2	Charger-Battery, 60V 2 Amp
8	120-9284	1	Pulley-Auger, Front				

60 Volt Powerhead Assembly No. 139-5315

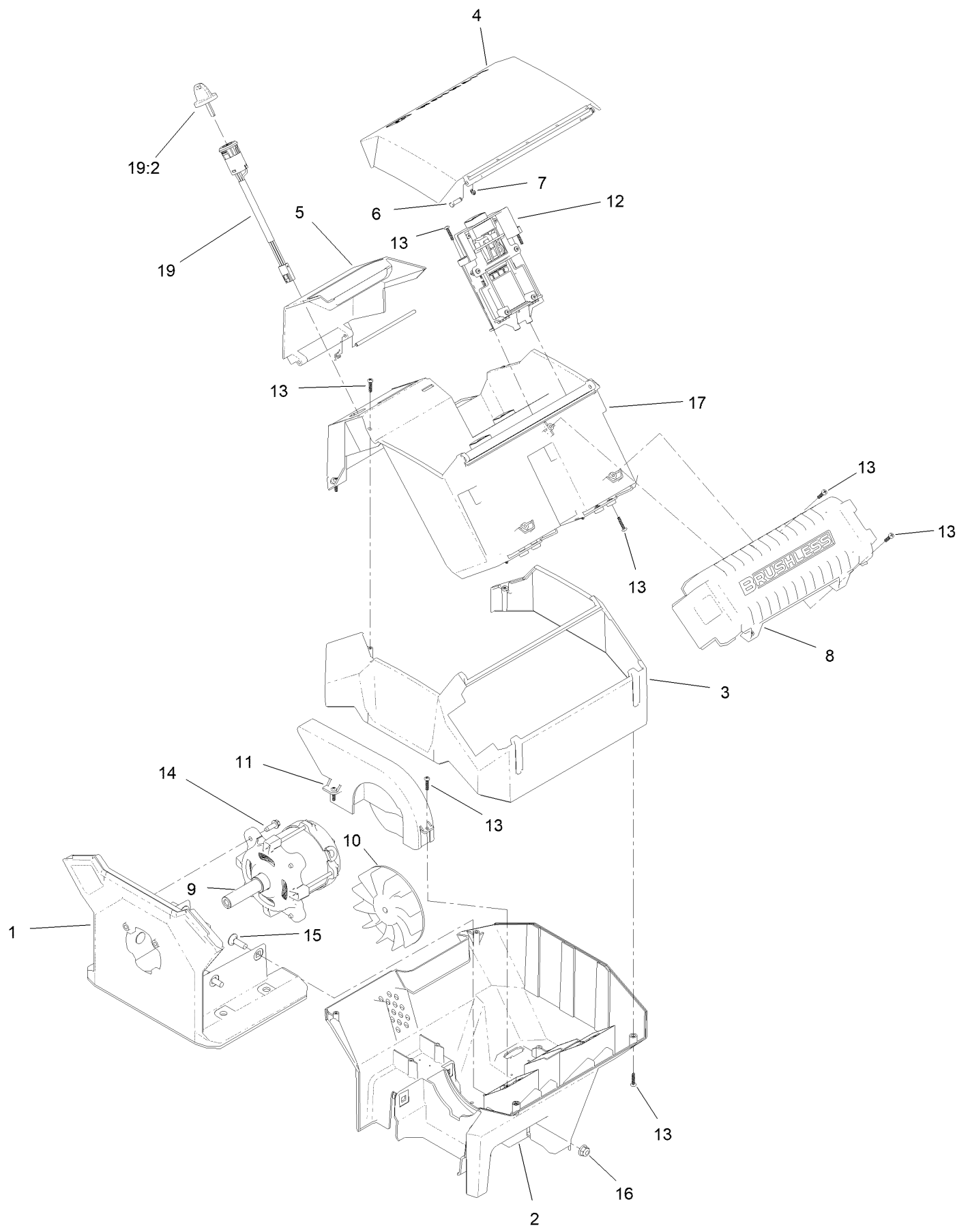

60 Volt Powerhead Assembly No. 139-5315 (continued)

<i>Ref.</i>	<i>Part Number</i>	<i>Qty.</i>	<i>Description</i>	<i>Ref.</i>	<i>Part Number</i>	<i>Qty.</i>	<i>Description</i>
1	139-5316	1	Motor Mount	11	139-5269	1	Cover-Fan
2	139-5317	1	Housing-Motor	12	137-9435	3	Battery Track Assembly
3	139-5318	1	Cover-Controller	13	94-4496	27	Screw-PPH
4	139-5320	1	Door-Top	14	49-2040	4	Screw-HWHTF
5	139-5321	1	Door-Bottom	15	3230-2	4	Bolt-CARR
6	131-3027	4	Pin-Throttle Cable	16	104-8300	4	Nut-HF, NI
7	110-1758	4	Ring-Retaining	17	139-5319	1	Bucket-Battery
8	147-9461	1	Motor Controller ASM-Powerhead	19	161-5981	1	Ignition ASM-Powerhead
9	139-5289	1	Motor-60V, 2 Stage	19:2	147-1755	1	Key-60V 2 Stage Power Head
10	139-5322	1	Fan-Fc				

Chute Assembly

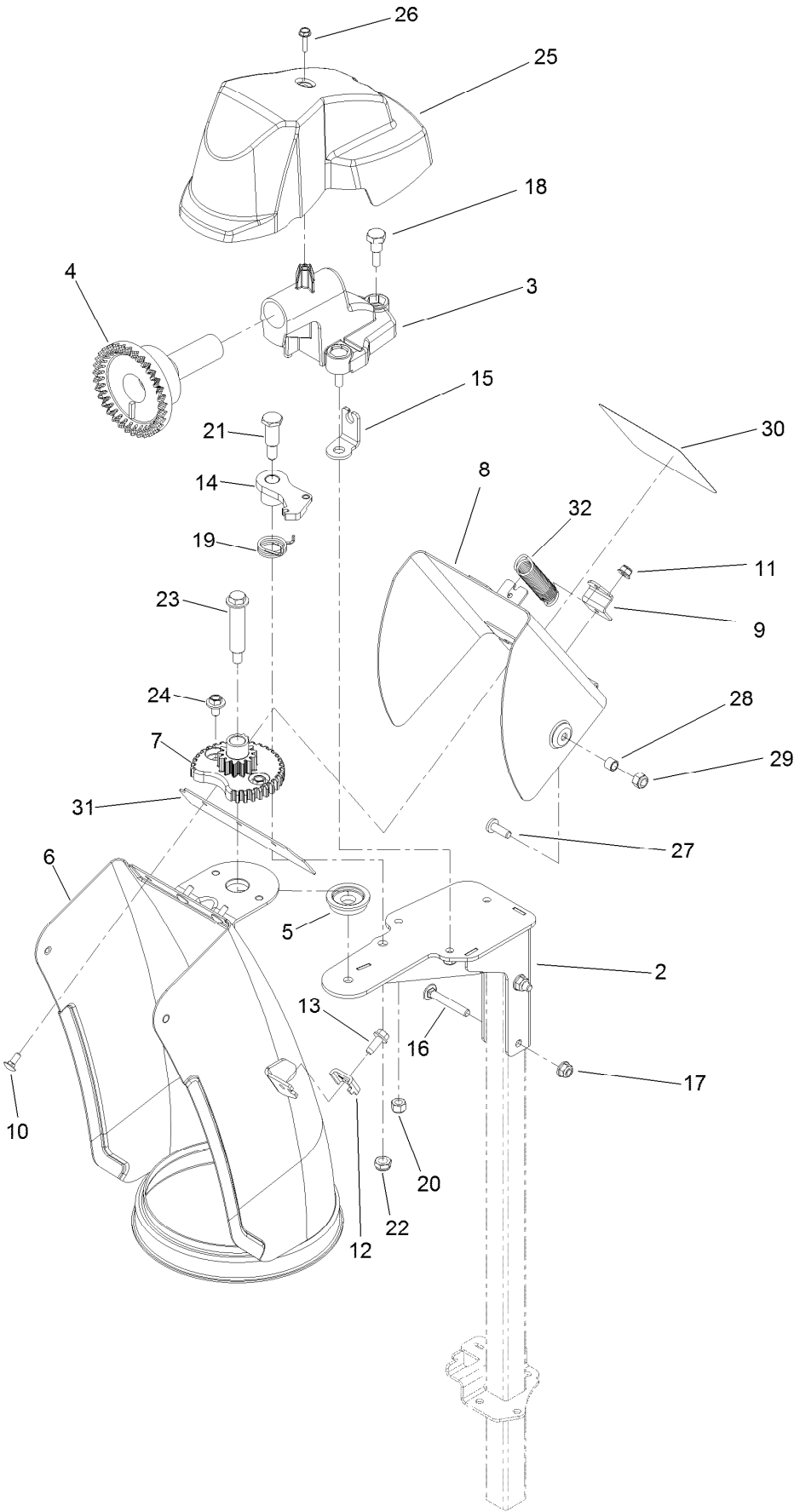

Chute Assembly (continued)

<i>Ref.</i>	<i>Part Number</i>	<i>Qty.</i>	<i>Description</i>	<i>Ref.</i>	<i>Part Number</i>	<i>Qty.</i>	<i>Description</i>
2	138-3605-03	1	Support-Chute	18	136-7197	3	Screw-Shoulder
3	138-3606	1	Mount-Gear, Face	19	108-7315	1	Spring-Torsion
4	106-4471	1	Gear-Face	20	137-3088	3	Nut-Hex
5	106-4422	1	Spacer-Chute	21	137-3103	1	Screw-Shoulder, HH
6	138-3611-01	1	Chute	22	137-3089	3	Nut-Hex
7	106-4472	1	Gear-Chute	23	136-7199	1	Bolt-Shoulder
8	138-3615-01	1	Deflector	24	46-6810	2	Screw And Washer ASM
9	138-3612-01	1	Bracket-Spring	25	138-3627	1	Cover-Chute, Gear
10	135-1929	3	Bolt-CARR	26	98-1375	1	Screw-HWH
11	138-0719	3	Nut-HF	27	138-0689	1	Screw-PH
12	136-7191	1	Clamp-Cable	28	138-3678	1	Spacer
13	137-3043	1	Screw-HWH	29	137-3094	1	Nut-Hex
14	106-4476	1	Latch-Chute	30	137-6198	1	Decal-Danger
15	138-3607	1	Anchor-Cable	31	138-3671	1	Gasket-Deflector
16	120-9698	2	Bolt-CARR	32	138-8493	1	Spring-Chute, Upper
17	119-4040	2	Nut-HF, NI				

Chute Control Assembly

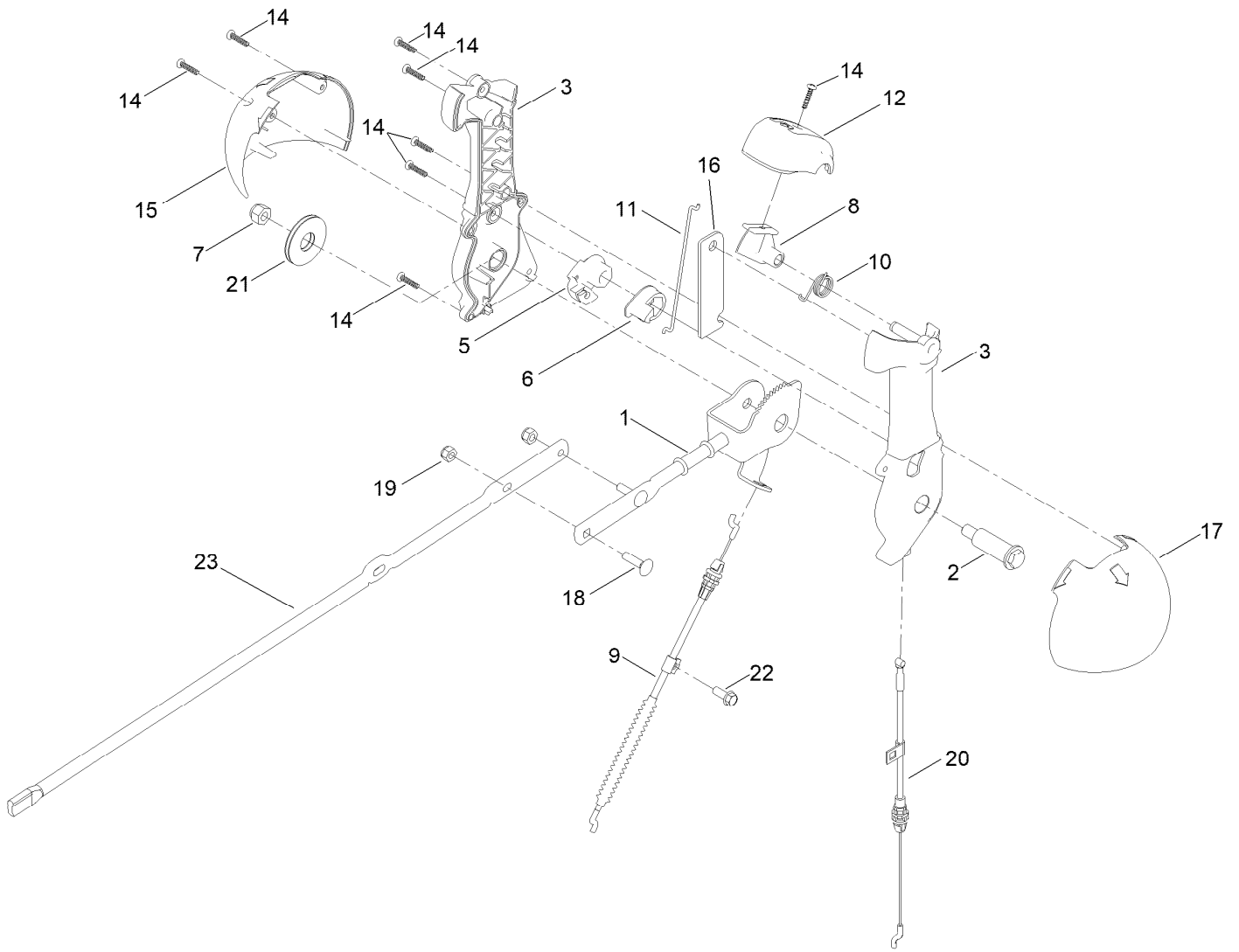

Chute Control Assembly (continued)

<i>Ref.</i>	<i>Part Number</i>	<i>Qty.</i>	<i>Description</i>	<i>Ref.</i>	<i>Part Number</i>	<i>Qty.</i>	<i>Description</i>
1	138-0662	1	Rod-Control, Chute	14	94-4496	8	Screw-PPH
2	138-0659	1	Screw-Shoulder, HWH	15	136-6677	1	Globe-Quickstick, RH
3	139-1552	1	Chute Control Lever ASM	16	136-6632	1	Plate-Stiffner
5	105-9988	1	Lever-Cable, Deflector	17	136-6678	1	Globe-Quickstick, LH
6	106-7310	1	Pawl-Latch	18	137-3056	3	Bolt-CARR
7	137-3087	1	Nut-Hex	19	137-3094	3	Nut-Hex
8	137-6238	1	Trigger-Latch	20	144-1237	1	Cable-Rotation, Chute
9	138-3672	1	Cable-Control, Deflector	21	138-0744	1	Washer-Friction, Composite
10	105-9982	1	Spring-Torsion	22	32144-85	1	Screw-HWH Thd Form
11	138-0688	1	Link-Latch	23	144-1236	1	Rod-Chute
12	137-6239	1	Cap-Lever				

Handle Assembly

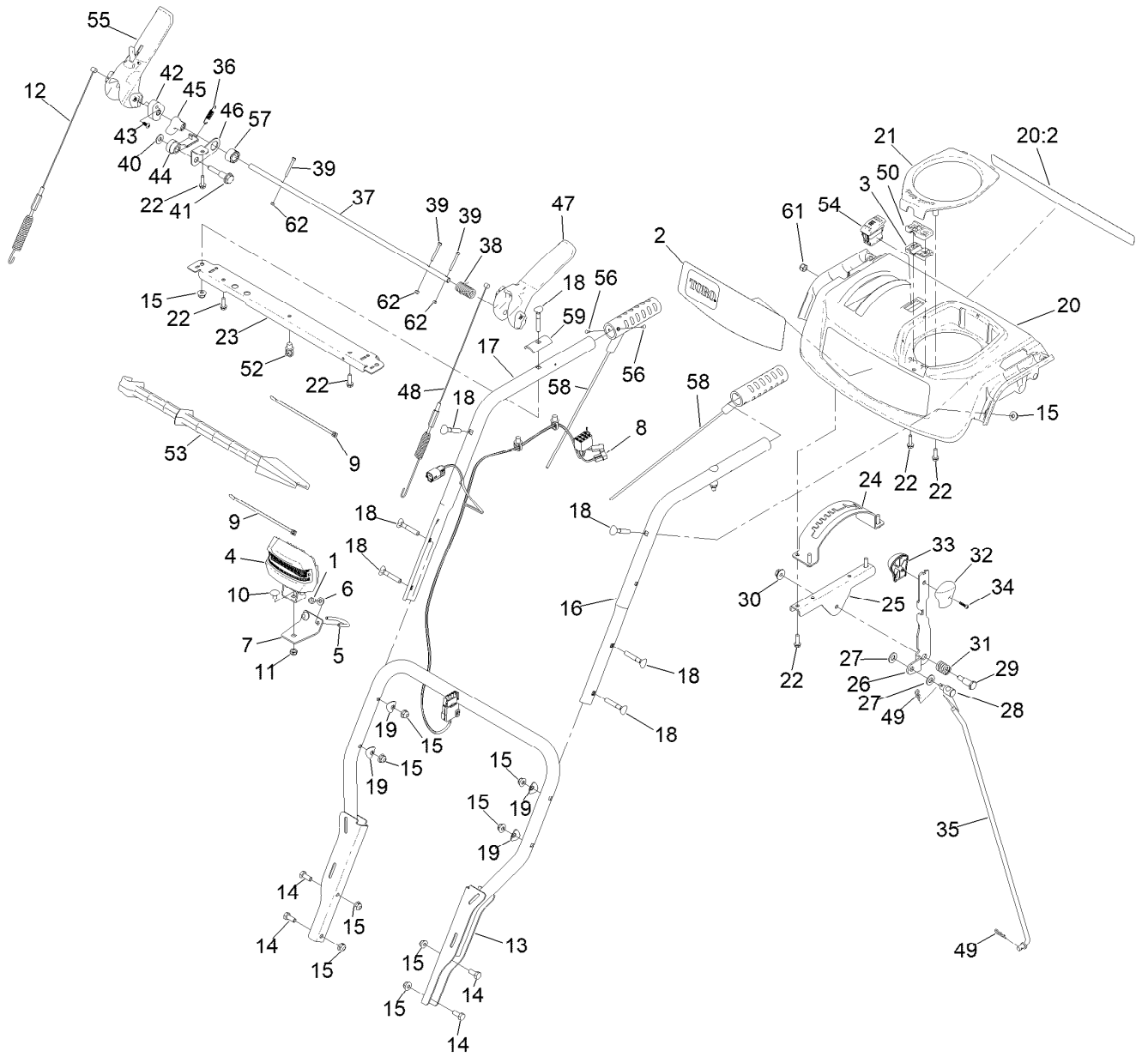

Handle Assembly (continued)

<i>Ref.</i>	<i>Part Number</i>	<i>Qty.</i>	<i>Description</i>	<i>Ref.</i>	<i>Part Number</i>	<i>Qty.</i>	<i>Description</i>
1	137-3094	2	Nut-Hex	31	136-7121	1	Spring-Compression
2	145-0852	1	Decal - Consol	32	105-9999	1	Knob-Shift, LH
3	139-3587	1	Support-Rod, Lower	33	106-4423	1	Knob-Shift, RH
4	138-0670	1	LED Light ASM	34	94-4496	1	Screw-PPH
5	136-7120	1	Clamp-Light	35	144-1239	1	Rod-Shift
6	137-3072	2	Washer-Flat	36	136-7161	1	Spring-Lockout, Handle
7	127-5961-03	1	Bracket-Light	37	137-6182	1	Rod-Lockout
8	145-0899	1	Harness-Wire, LED And Hand Warmers	38	138-0678	1	Spring-Torsion, Handle Return
9	614249	3	Tie-Cable	39	145-0660	3	Screw-HSH,Spl
10	3230-19	1	Bolt-CARR	40	98-3499	1	Washer-Flat
11	137-3089	1	Nut-Hex	41	138-0681	1	Screw-Shoulder
12	121-6812	1	Cable-Auger	42	144-0320	1	Handle Lock
13	139-3574-03	1	Handle-Lower, Weld ASM	43	137-9137	1	Screw-PPH
14	137-3052	4	Screw-HH	44	144-0321	1	Latch, Lockout
15	138-8401	12	Nut-HF	45	138-8466	1	Cam-Lockout
16	137-6206-03	1	Handle-Upper, LH	46	138-3652	1	Link-Lockout
17	137-6207-03	1	Handle-Upper, RH	47	137-6171	1	Lever-Control
18	137-3107	8	Screw-Handle	48	144-0323	1	Cable-Traction
19	137-3009	4	Washer-Cup	49	137-3083	2	Pin-Hair
20	145-0665	1	Control Panel Assembly	50	139-3588	1	Support-Rod, Upper
20:2	137-6249	1	Decal-Safety	52	32180-030	1	Clip-Tie
21	137-6178	1	Cover-Quickstick	53	110-3408	1	Stick-Cleanout
22	137-3099	9	Screw-Plastite, HWH	54	122-1124	1	Switch-Rocker, On-None-Off (Heater)
23	145-4075-01	1	Brace-Console	55	145-0871	1	Auger Control ASM
24	137-6187-03	1	Gate-Shift	56	3290-271	4	Rivet-Pop
25	137-6188-03	1	Bracket-Shift	57	138-8467	1	Collar-Cam
26	144-2827-03	1	Selector-Speed	58	144-1604	2	Grip-Heated
27	115-1166	2	Washer-Plain	59	145-0872-03	1	Handle Saddle
28	136-7193	1	Trunnion-Rod	61	137-3093	1	Nut-Hex
29	137-3103	1	Screw-Shoulder, HH	62	140-3749	3	Nut-Lock Rohs
30	137-3038	1	Nut-HF				

Attachments and Accessories

For 39926 Power Max e26 60V Snowthrower

Product Name	Model/Part
Weight Kit	107-3815
Snow Cab Kit.....	127-5960
Non-Marking Skid Kit.....	38211
Heavy-Duty Skid Kit.....	38212
Drift Breaker Kit	38213
Toro Snow Oil 0W30 Synthetic 20-Ounce Bottle	38913
Toro 2-Stage Cover.....	490-7466
Plain 2-Stage Cover.....	490-7467

Notes:



Count on it.