



11x6.5-5 Pneumatic Caster Tire Kit

Grandstand® HD Mower

Model No. 161-3470

Installation Instructions

Installation

Loose Parts

Use the chart below to verify that all parts have been shipped.

Description	Qty.	Use
Caster fork assembly	2	Install the kit.
Washer	6	
Locknut	2	



Preparing the Machine

1. Park the machine on a level surface.
2. Disengage the PTO.
3. Move the motion-control levers outward to the NEUTRAL-LOCK position.
4. Shut off the engine and remove the key.
5. Wait for all moving parts to stop.

⚠ WARNING

Mechanical or hydraulic jacks may fail to support the machine and cause serious injury.

Use jack stands when supporting the machine.

6. Raise the front of the machine so that the casters are off the ground. Support the machine using jack stands.

Note: Use jack stands rated for your machine. Refer to the *Operator's Manual* for your machine to determine the weight.

Installing the Kit

1. Remove both of the caster fork assemblies from the caster hubs as shown below.

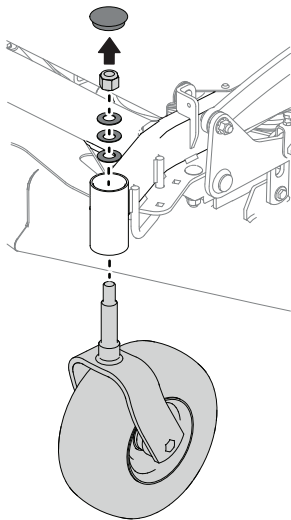

Figure 1

g494554

2. Apply grease to the caster spindle on the new caster fork assembly.

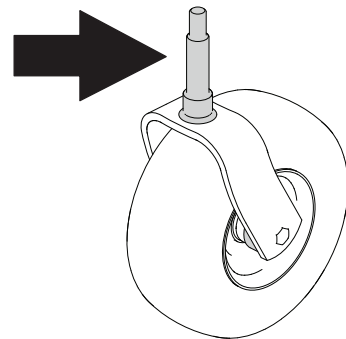

Figure 2

g495454

3. Install the new caster fork assembly, 3 washers, and locknut to each caster hub.

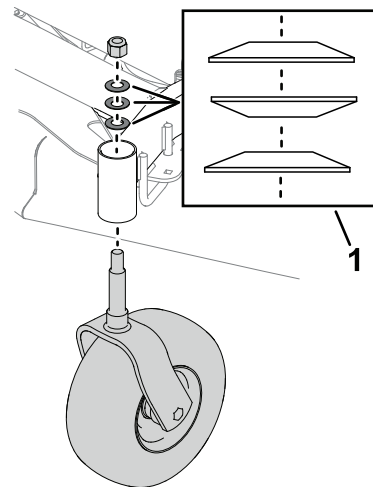

Figure 3

g494557

1. Washer orientation

4. Torque the top nuts to 142 to 197 N·m (105 to 145 ft·lb) and back them off 1/4 turn.
5. Install the grease caps to the caster hubs.
6. Inflate the caster tires to 324 kPa (47 psi).