



Topdresser 2500

Model No. 44507—230000001 and Up

Parts Catalog

Ordering Replacement Parts

To order replacement parts, please supply: the part number, the quantity, and the description of each part desired.

Understanding Reference Numbers

Each identified part in an illustration has a reference number. The reference number for a part also appears in the parts list, along with other information about the part.

This catalog uses two special reference number formats, one to indicate parts in a service assembly and another to indicate the quantity of a given part in an illustration.

Service Assembly Reference Numbers

Parts in service assemblies have reference numbers in the form **a:b**. The **a** represents the reference number of the entire service assembly and the **b** represents a sequential number unique to each part within the service assembly.

For example, a wheel assembly might be identified by reference number **6**, the tire by **6:1**, the valve by **6:2**, and the wheel by **6:3**. When you order the assembly identified by reference number **6**, you receive all parts identified by reference numbers **6:1**, **6:2**, and **6:3**. However, you may also order any part individually.

Reference numbers of this type appear in illustrations and in part lists.

Reference Numbers Indicating Quantity

In an illustration, if a reference number indicates more than one part, the reference number has the form **nX y**. The **n** represents the quantity of the part, the **X** is the multiplication symbol, and the **y** represents the reference number.

For example, in an illustration, the reference number **2X 37** means that two of the parts identified by reference number **37** are indicated.

Contents

Description	Page	Description	Page
Cradle Assembly	3	Brush and Motors Assembly	10
Cradle and Trailer Assembly	4	Hopper Assembly	11
Hydraulic Manifold Assembly	6	Gate Slide and Brush Guard Assembly	12
Hydraulic Installation Assembly	7	Chain, Sprocket and Guard Assembly	13
Slider Bed and Roller Assembly	8	Hydraulic Schematic	14
Gate Assembly	9	Electrical Schematic	15

Accessories

Description	Model / Part No.	Description	Model / Part No.
Hydraulic Brake Kit	99-0154	Hydraulic Filter	86-3010
Mobil EAL 224H (5 gallon)	100-7674	Tongue Jack	98-5016
(or contact distributor)		(required for CE compliance)	

Part Description Abbreviations

Part descriptions in this catalog may include the following abbreviations.

Abbreviation	Meaning	Abbreviation	Meaning
AR	as required	HYD	hydraulic
ASM	assembly	INC	incorporated
CARR	carriage	LH	left hand
DEG	degrees	NI	nylon insert
FH	flat head	PPH	Phillips pan head
GA	gauge	PTH	Phillips truss head
HF	hex flange	PTO	power take off
HH	hex head	RH	right hand
HHF	hex head flange	SFH	slotted fillister head
HLH	hex lag head	SHH	slotted hex head
HJ	hex jam	SQH	square head
HOC	height-of-cut	SHWH	slotted hex washer head
HS	hex socket	SPH	slotted pan head
HSBH	hex socket button head	SRH	slotted round head
HSFH	hex socket flat head	STD	standard
HSH	hex socket head	TAP	self tapping
HWH	hex washer head	TTH	Torx truss head
HWHTF	hex washer head thread forming	WH	wing head

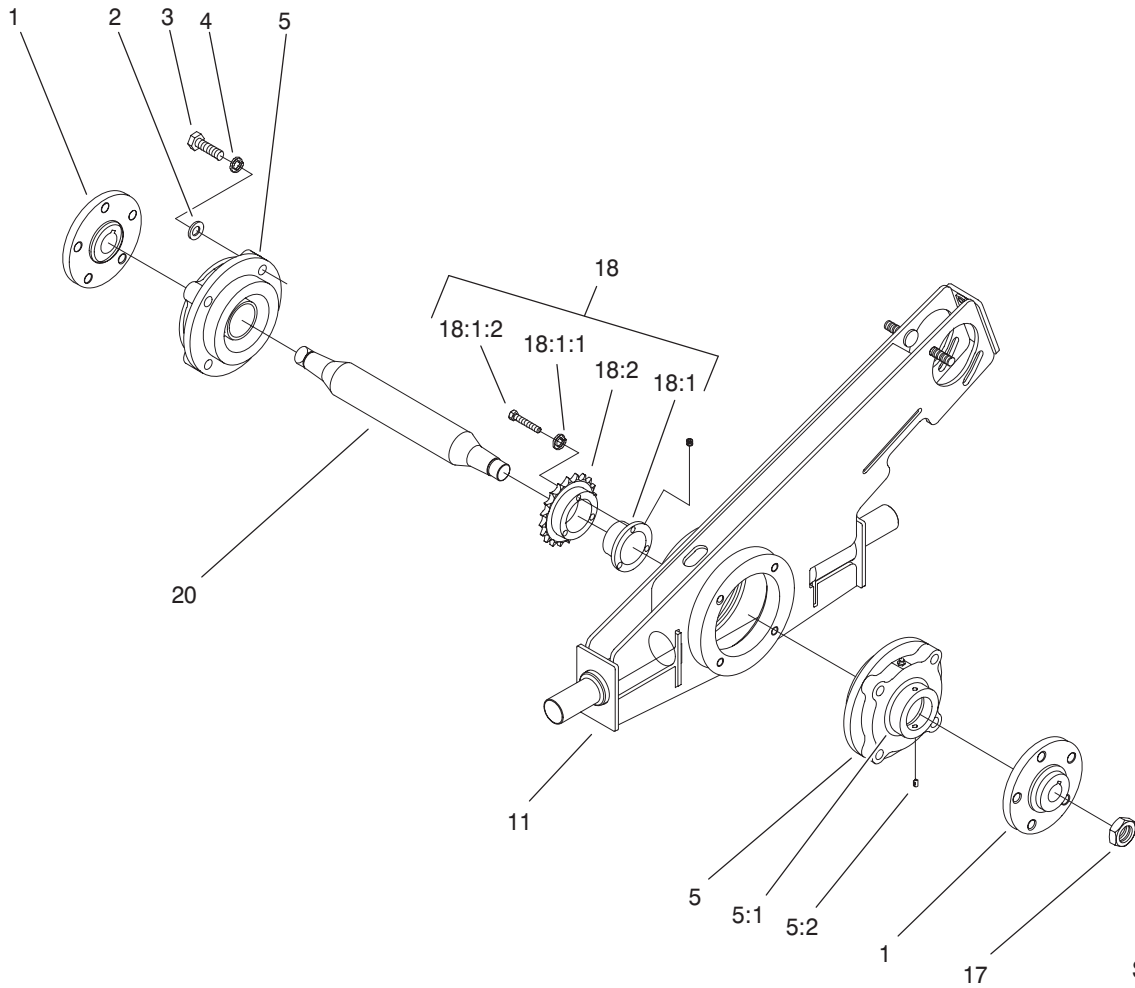

Sheet No.:2

Cradle Assembly

Ref. No.	Part No.	Qty.	Description
1	100-1418-03	4	Hub
2	3256-26	16	Washer-Flat
3	325-7	16	Screw-HH
4	3253-7	16	Washer-Lock
5	100-1455	4	Bearing
5:1	99-0194	1	Collar-Locking
5:2	99-0195	1	Screw-Set, HS
11	100-1488-03	2	Cradle ASM
17	26-3790	4	Nut-Lock
18	100-7690	2	Sprocket And Hub ASM
18:1	100-7730	1	Bushing
18:1:1	3253-18	3	Washer-Lock/Sp
18:1:2	32104-96	3	Screw-HH
18:2	100-7731	1	Sprocket-Driven, 20 Tooth
20	100-1490	2	Axle-Cradle

Ref. No.	Part No.	Qty.	Description

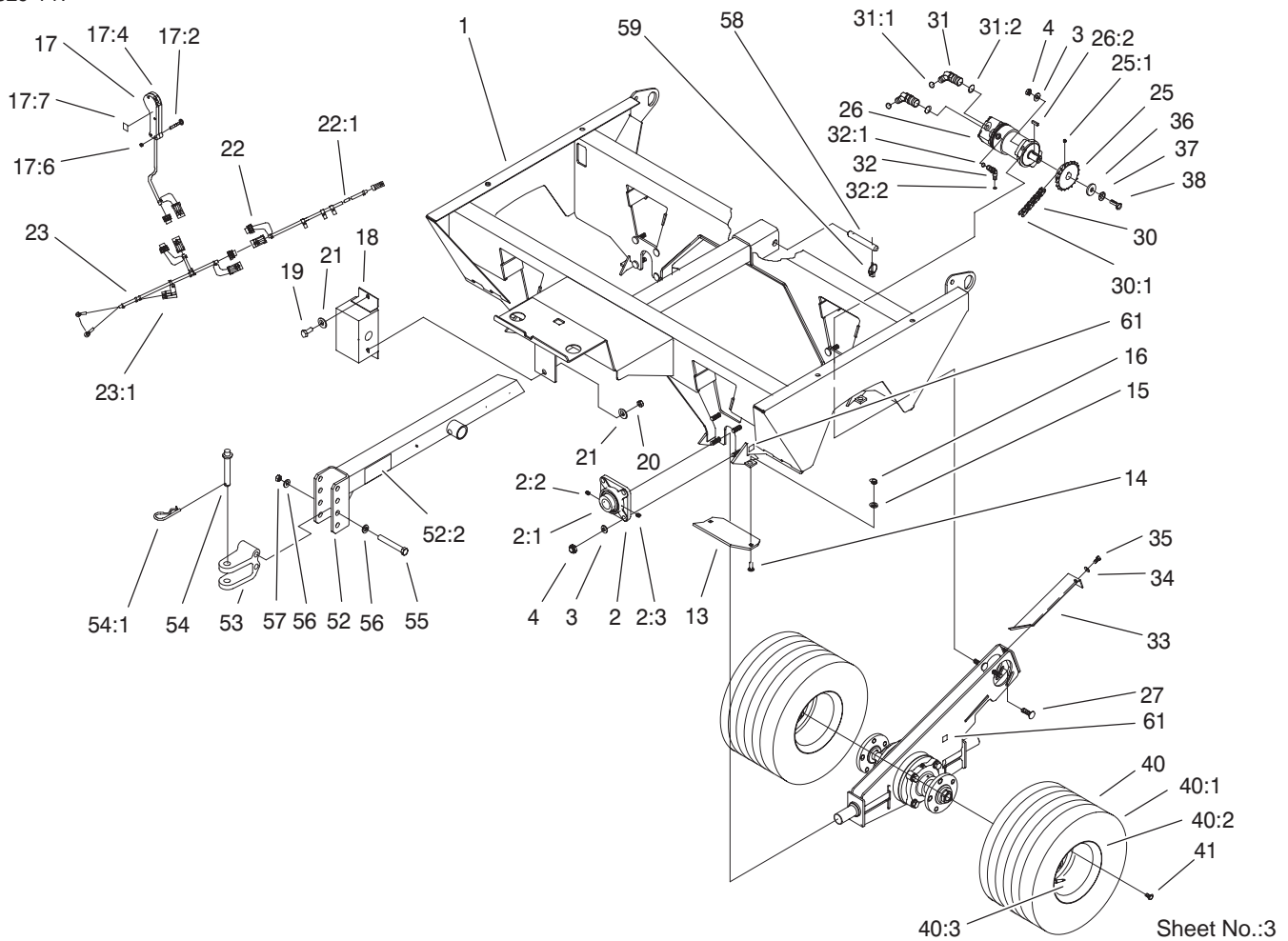

Cradle and Trailer Assembly

Ref. No.	Part No.	Qty.	Description
1	100-1480-01	1	Frame-T trailer
2	100-1456	4	Bearing
2:1	01-172-0090	1	Collar-Lock
2:2	3246-16	1	Screw-Set
2:3	302-2	1	Fitting-Grease
3	3256-26	20	Washer-Flat
4	3296-23	20	Nut-Lock, NI
13	100-7678-01	4	Plate-Skid
14	3231-25	8	Screw-CARR
15	3256-25	8	Washer-Flat
16	3296-39	8	Nut-Lock, NI
17	100-7680	1	Control Handle ASM
17:2	100-7681	4	Screw-Srh
17:4	01-603-0760	1	Boot-Rubber
*17:5	01-603-0750	1	Switch-Pole, Single
17:6	3217-32	4	Nut-Hex
17:7	100-7682	2	Decal-On/Of f
18	100-1410-03	1	Pump-Charge
19	325-5	2	Screw-HH
20	3296-45	2	Nut-Lock, NI
21	3256-6	4	Washer-Flat
22	99-0008	1	Harness-Wire, Trailer
22:1	100-4918	1	Diode
23	99-0198	1	Harness-Wire, Battery
23:1	110928	1	Fuse-5 Amp

Ref. No.	Part No.	Qty.	Description
25	100-7691	2	Sprocket-Chain, Roller
25:1	3246-3	2	Screw-HS
26	100-1459	2	Motor-HYD
*26:1	100-1466	1	Kit-Seal
26:2	5-7280	1	Key
27	100-7698	2	Bolt-Carriage
30	100-1472	2	Chain-Cradle, Roller
30:1	2710-16	1	Link-Chain
31	340-14	4	Fitting-HYD, 45°
31:1	237-65	1	O-Ring
31:2	237-80	1	O-Ring
32	340-103	2	Fitting-HYD, 45°
32:1	237-78	1	O-Ring
32:2	237-21	1	O-Ring
33	100-1452	2	Cover-Cradle, Top
34	3256-24	2	Washer-Flat
35	323-4	2	Screw-HH
36	71-5320	2	Washer-Support, Engine
37	3253-4	2	Washer-Lock
38	322-3	2	Screw-HH
40	99-0169	4	Wheel And Tire ASM
40:1	99-0173	1	Tire
40:2	99-0174	1	Rim

* Not illustrated

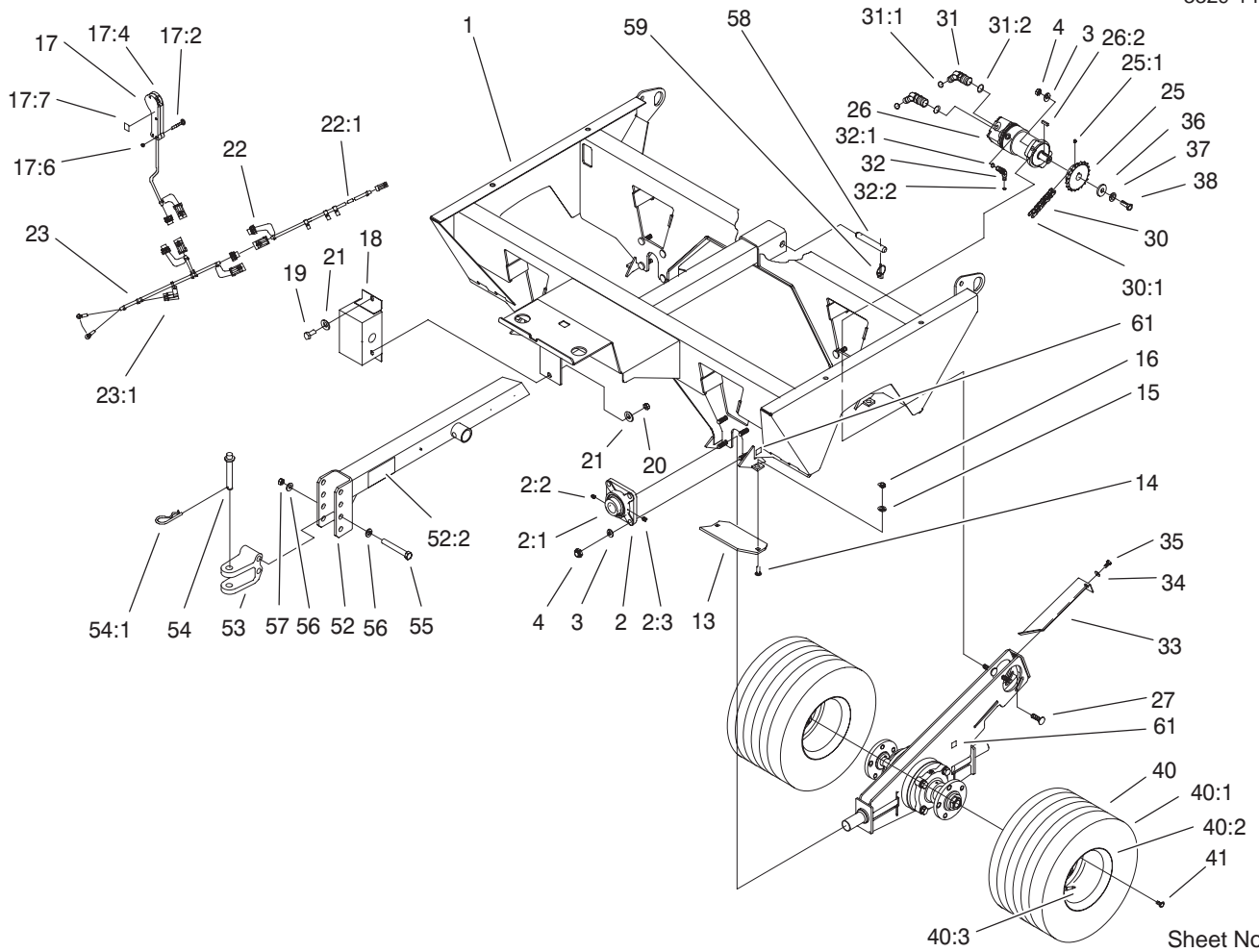

Cradle and Trailer Assembly (Continued)

Ref. No.	Part No.	Qty.	Description
40:3	232-27	1	Stem-Valve
41	71-4450	20	Bolt-Lug
52	100-7686	1	Tongue ASM
52:2	100-7679	1	Decal-W arning
53	47-3550-01	1	Clevis-Hitch
54	13-6200	1	Hitch-Pointed, Pin
54:1	3290-343	1	Pin-Hair
55	327-12	2	Screw-HH
56	3256-7	4	Washer-Flat
57	3296-53	2	Nut-Lock, NI
58	100-7694	2	Pin-Clevis
59	92-1298	4	Pin-Lynch
61	58-6520	8	Decal-Grease

Ref. No.	Part No.	Qty.	Description

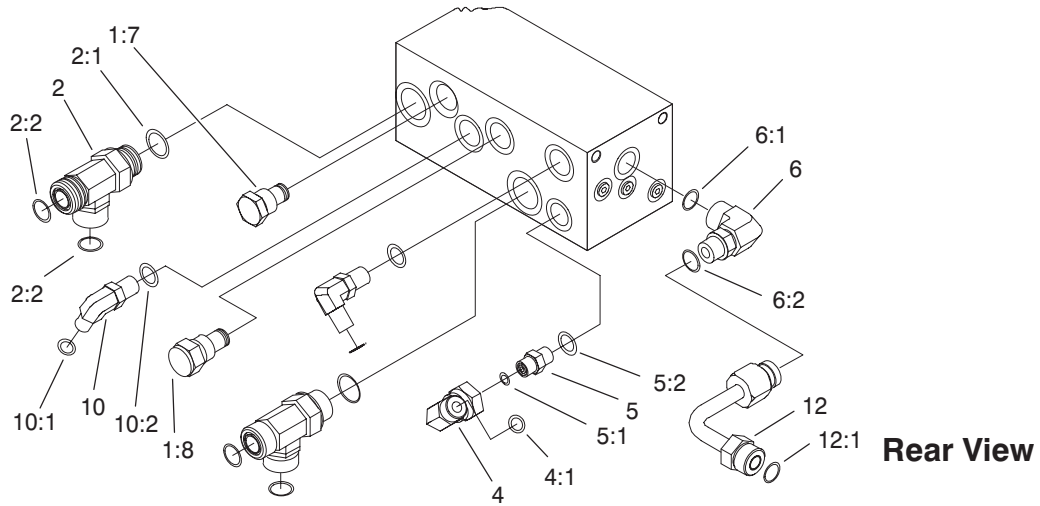

Rear View

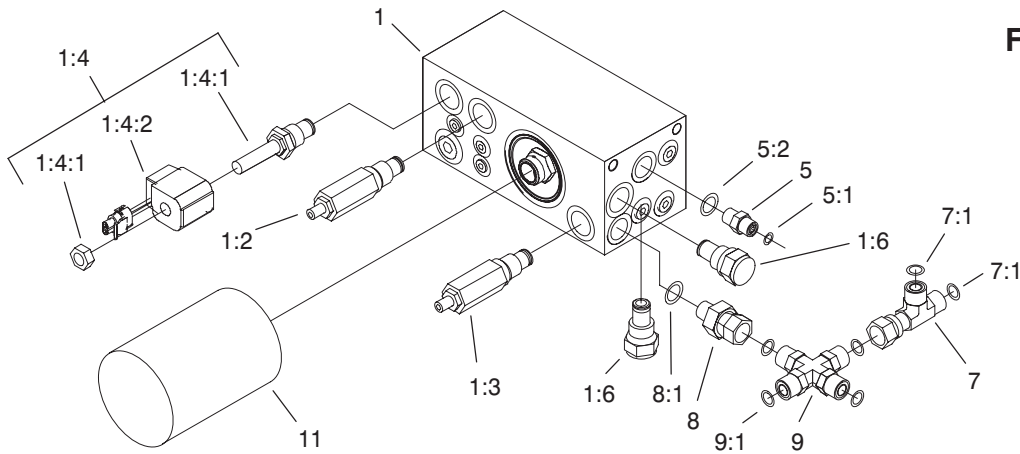

Front View

Sheet No.:4

Hydraulic Manifold Assembly

Ref. No.	Part No.	Qty.	Description
1	100-7728	1	Manifold-HYD
1:2	100-7740	1	Valve-Relief
1:3	100-7717	1	Valve-Relief
1:4	100-7699	1	Valve-Solenoid
1:4:1	100-7718	1	Valve-Solenoid
1:4:2	100-7720	1	Coil-Soleniod
1:6	100-7721	2	Valve-Check
1:7	100-7723	1	Valve-Check
1:8	100-7722	1	Valve-Check
2	340-148	2	Fitting-Tee
2:1	237-81	1	O-Ring
2:2	237-58	2	O-Ring
4	94-6031	1	Fitting-HYD
4:1	237-30	1	O-Ring
5	340-4	2	Adapter
5:1	237-30	1	O-Ring
5:2	237-79	1	O-Ring
6	340-98	1	Fitting-HYD, 90°
6:1	237-79	1	O-Ring
6:2	237-30	1	O-Ring
7	340-104	1	Tee-Fitting
7:1	237-30	2	O-Ring
8	100-7671	1	Adapter-HYD
8:1	237-79	1	O-Ring
9	100-7670	1	Adapter-HYD
9:1	237-151	4	O-Ring

Ref. No.	Part No.	Qty.	Description
10	340-17	2	Fitting-HYD, 90°
10:1	237-65	1	O-Ring
10:2	237-80	1	O-Ring
11	86-3010	1	Filter-Oil, Transmission
12	100-7713	1	Hydraulic Tube ASM
12:1	237-151	1	O-Ring

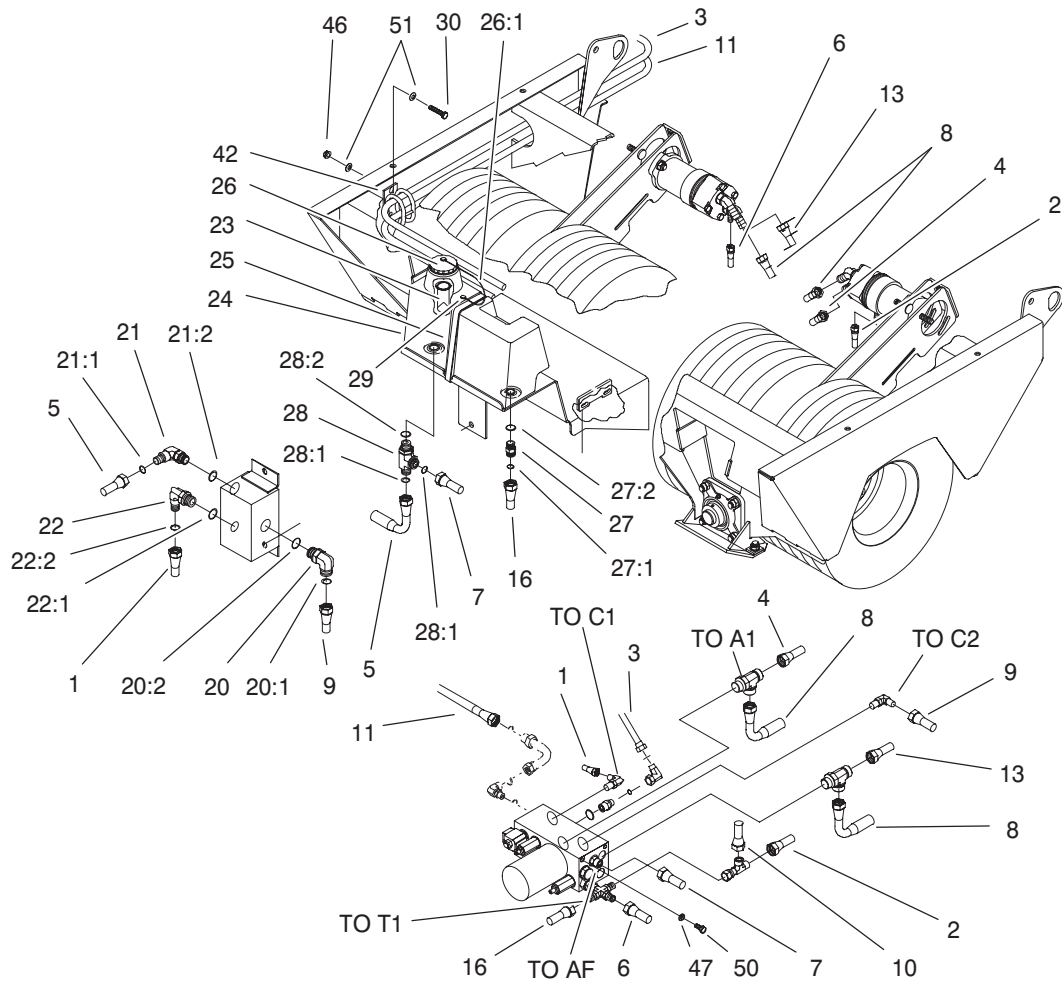

Sheet No.:5

Hydraulic Installation Assembly

Ref. No.	Part No.	Qty.	Description
1	100-7655	1	HYD Hose ASM
2	100-7664	1	HYD Hose ASM
3	104-0304	1	HYD Hose ASM
4	100-7662	1	HYD Hose ASM
5	100-7657	1	HYD Hose ASM
6	100-7663	1	HYD Hose ASM
7	100-7658	1	HYD Hose ASM
8	100-7661	2	HYD Hose ASM
9	100-7656	1	HYD Hose ASM
10	100-7669	1	HYD Hose ASM
11	104-0303	1	HYD Hose ASM
13	100-7672	1	HYD Hose ASM
16	100-7668	1	HYD Hose ASM
20	340-142	1	Fitting-HYD, 90°
20:1	237-58	1	O-Ring
20:2	237-81	1	O-Ring
21	340-17	1	Fitting-HYD, 90°
21:1	237-65	1	O-Ring
21:2	237-80	1	O-Ring
22	340-139	1	Fitting-HYD, 90°
22:1	237-81	1	O-Ring
22:2	237-65	1	O-Ring
23	92-1705	1	Filter-Screen
24	94-4700	1	Tank-HYD
25	100-7693	1	Clamp-Tank
26	93-4365	1	Cap-Oil

Ref. No.	Part No.	Qty.	Description
26:1	75-0540	1	Tether And Button Kit
27	340-4	1	Adapter
27:1	237-30	1	O-Ring
27:2	237-79	1	O-Ring
28	340-22	1	Adapter
28:1	237-65	2	O-Ring
28:2	237-80	1	O-Ring
29	3290-126	1	Screw
30	322-5	2	Screw-HH
42	99-5621	1	Guide-Hose
46	3296-29	2	Nut-Lock, NI
47	3256-24	4	Washer-Flat
50	323-5	4	Screw-HH
51	3256-23	4	Washer-Flat
*99	100-7674	1	Oil-HYD, 5 Gallon
*99:1	99-0010	1	Decal-Fluid, HYD

* Not illustrated

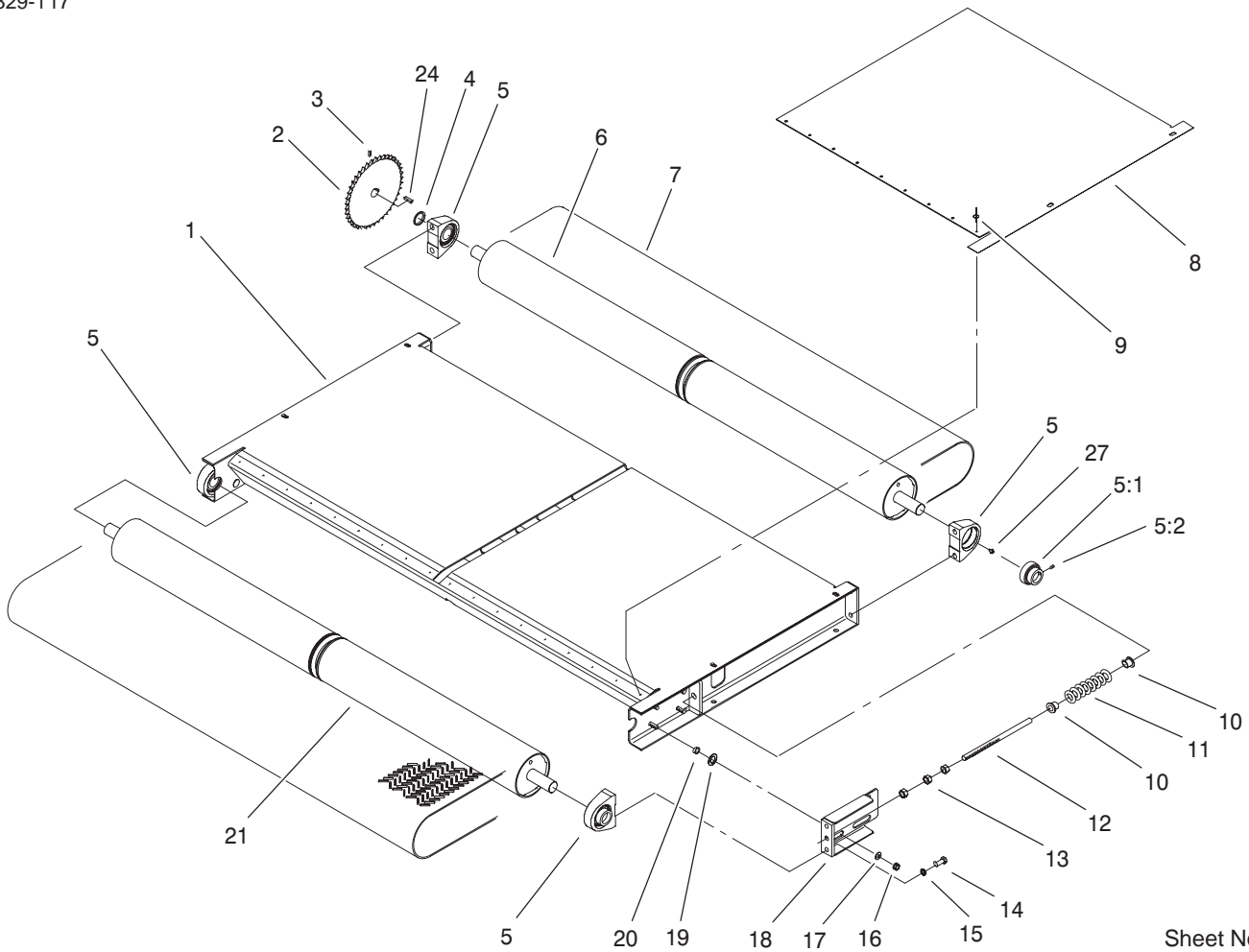

Sheet No.:6

Slider Bed and Roller Assembly

Ref. No.	Part No.	Qty.	Description
1	99-0038-01	1	Frame-Bed, Slider
2	99-0166-03	1	Sprocket-Driven
3	3246-3	2	Screw-HS
4	99-0017-01	1	Spacer-Sprocket
5	99-0158	4	Bearing-Base, Tapped
5:1	251-246	1	Collar W/Set Screws
5:2	3245-35	1	Screw-HS
6	99-0046	1	Roller-Rear
7	100-1425	1	Belt Kit
8	99-0047	2	Plate-W ear
9	3269-28	18	Rivet-Pop
10	100-1414	4	Holder-Spring
11	99-0163	2	Spring-Compression
12	99-01 18	2	Pin-Spring
13	3217-9	6	Nut-HH
14	100-1438	8	Screw-Socket Head, Torx
15	3253-6	8	Washer-Lock
16	3296-39	8	Nut-Lock, NI
17	3256-4	8	Washer-Flat
18	99-0050-01	2	Spring Plate ASM
19	99-0052	8	Washer-Slide
20	100-1401	8	Spacer-Slide, Spring
21	99-0044	1	Roller-Front
24	10-7070	1	Key-Square
27	302-33	4	Fitting-Grease

Ref. No.	Part No.	Qty.	Description

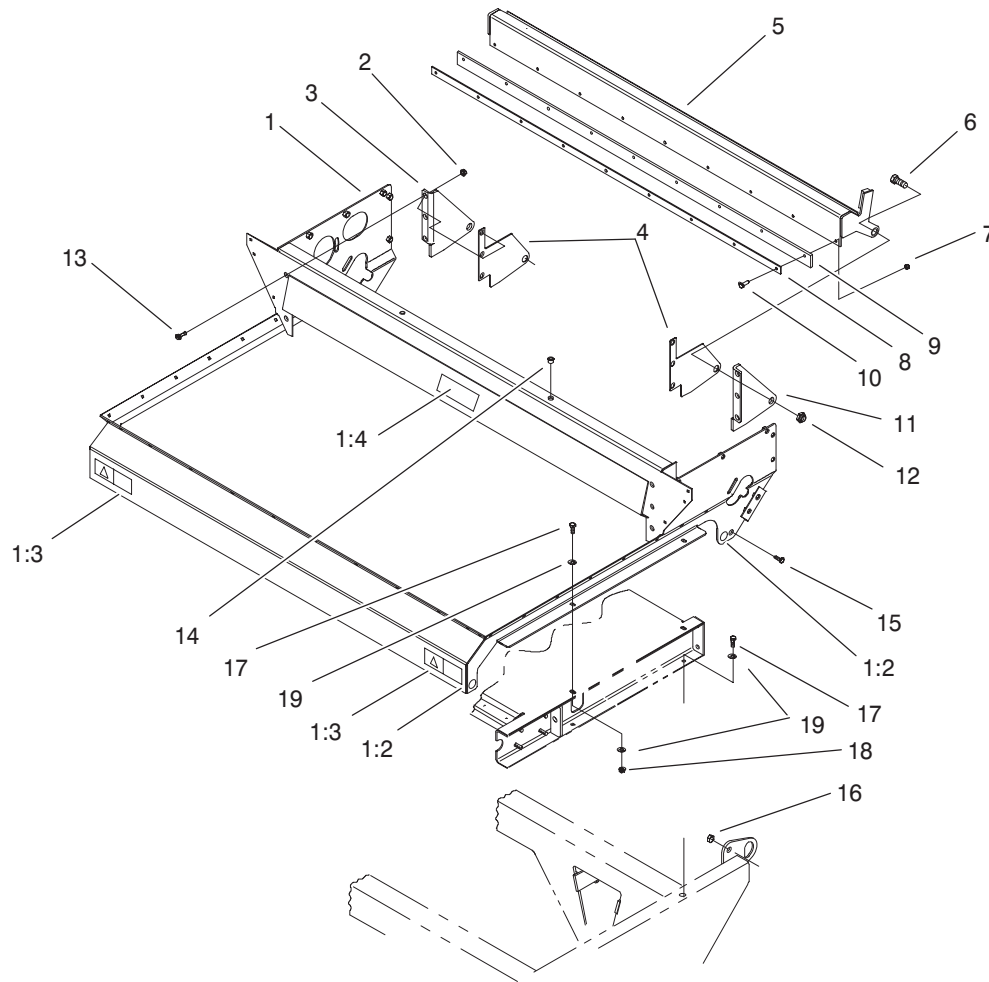

Sheet No.:7

Gate Assembly

Ref. No.	Part No.	Qty.	Description
1	100-1435	1	Hopper Frame ASM
1:2	58-6520	4	Decal-Grease
1:3	93-9092	2	Decal-W arning
1:4	105-4586	1	Decal-Shield
2	32128-37	6	Nut-HF
3	99-0079-01	1	Bracket-Gate Pivot, RH
4	99-01 17	2	Wareplate-Gate
5	99-0068-01	1	Gate ASM
6	328-24	2	Screw-HH
7	3296-29	9	Nut-Lock, NI
8	99-0089-01	1	Plate-Backing
9	99-0074	1	Seal-Gate
10	322-6	9	Screw-HH
11	99-0078-01	1	Bracket-Gate Pivot, LH
12	3296-51	2	Nut-Lock, NI
13	324-4	6	Screw-HH
14	32148-9	2	Insert-Nut
15	325-5	2	Screw-HH
16	3296-23	2	Nut-Lock, NI
17	323-7	8	Screw-HH
18	3296-39	4	Nut-Lock, NI
19	3256-24	12	Washer-Flat

Ref. No.	Part No.	Qty.	Description

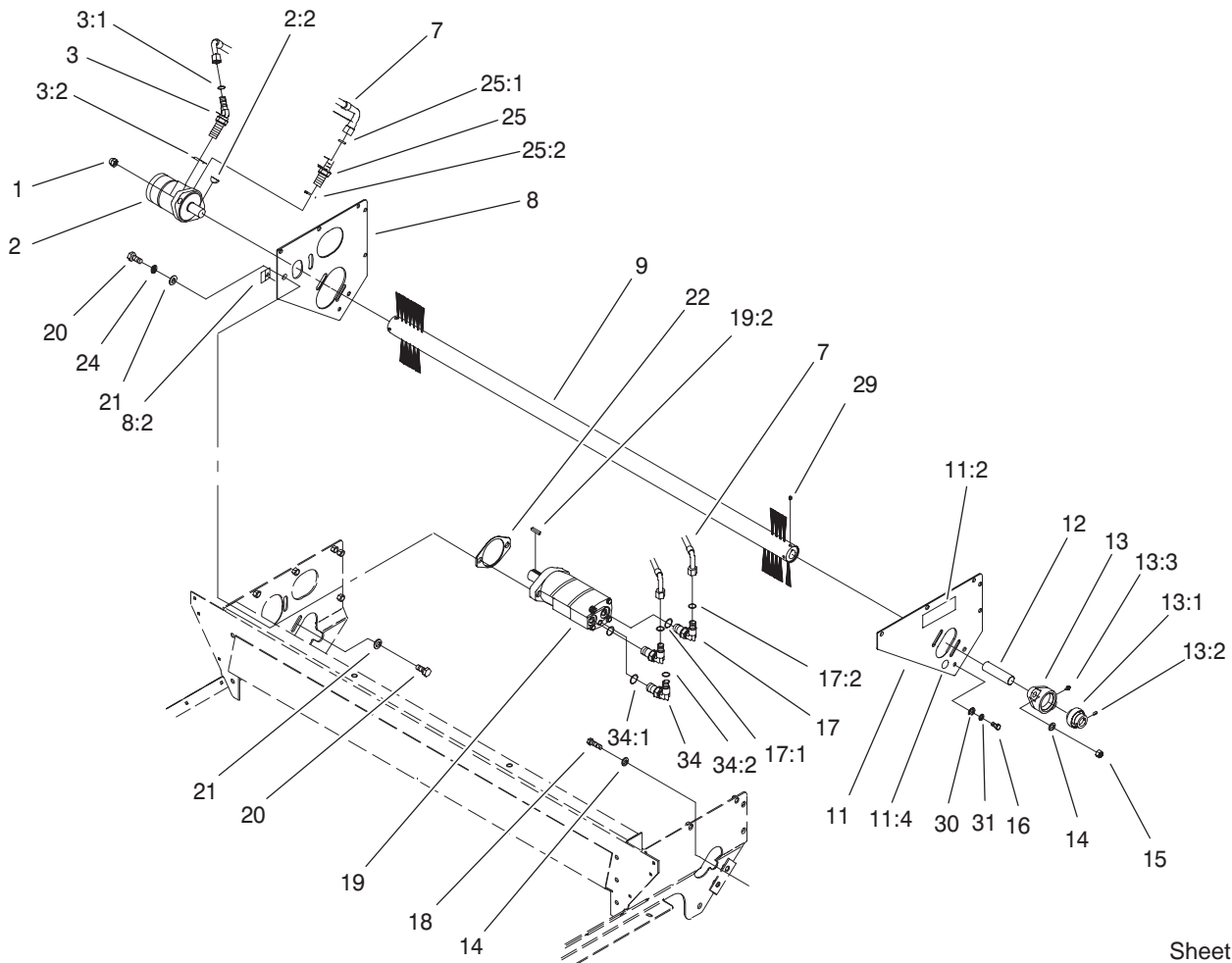

Sheet No.:8

Brush and Motors Assembly

Ref. No.	Part No.	Qty.	Description
1	3296-45	2	Nut-Lock, NI
2	99-0156	1	Motor-HYD
*2:1	100-1446	1	Seal Kit
2:2	3257-8	1	Key-W oodruff
3	340-89	1	Fitting-HYD, 45°
3:1	237-30	1	O-Ring
3:2	237-80	1	O-Ring
7	99-0177	1	Hose-HYD
8	100-1431	1	RH Motor Brace ASM
8:2	105-4586	1	Decal-Shield
9	99-0162	1	Brush
11	100-1430	1	LH Motor Brace ASM
11:2	106-7750	1	Decal-Danger
11:4	58-6520	1	Decal-Grease
12	99-0041	1	Shaft-Brush
13	99-0160	1	Bearing
13:1	251-249	1	Collar W/Set Screws
13:2	3245-35	1	Screw-HS
13:3	302-2	1	Fitting-Grease
14	3256-25	4	Washer-Flat
15	3296-48	2	Nut-Lock NI
16	323-4	4	Screw-HH
17	340-105	2	Fitting-HYD, 90°
17:1	237-80	1	O-Ring
17:2	237-30	1	O-Ring
18	324-6	2	Screw-HH

Ref. No.	Part No.	Qty.	Description
19	99-0155	1	HYD Motor Conveyor ASM
*19:1	100-1447	1	Seal Kit
19:2	10-7070	1	Key-Square
20	325-6	4	Screw-HH
21	3256-26	4	Washer-Flat
22	99-0116	1	Plate-Spacer
24	3253-7	2	Washer-Lock
25	340-6	1	Fitting-HYD, Straight
25:1	237-30	1	O-Ring
25:2	237-80	1	O-Ring
29	3246-3	4	Screw-HS
30	3256-24	4	Washer-Flat
31	3253-21	4	Washer-Lock
34	100-7695	1	Adapter-HYD
34:1	237-78	1	O-Ring
34:2	237-21	1	O-Ring
*99	3290-379	4	Tie-Cable

* Not illustrated

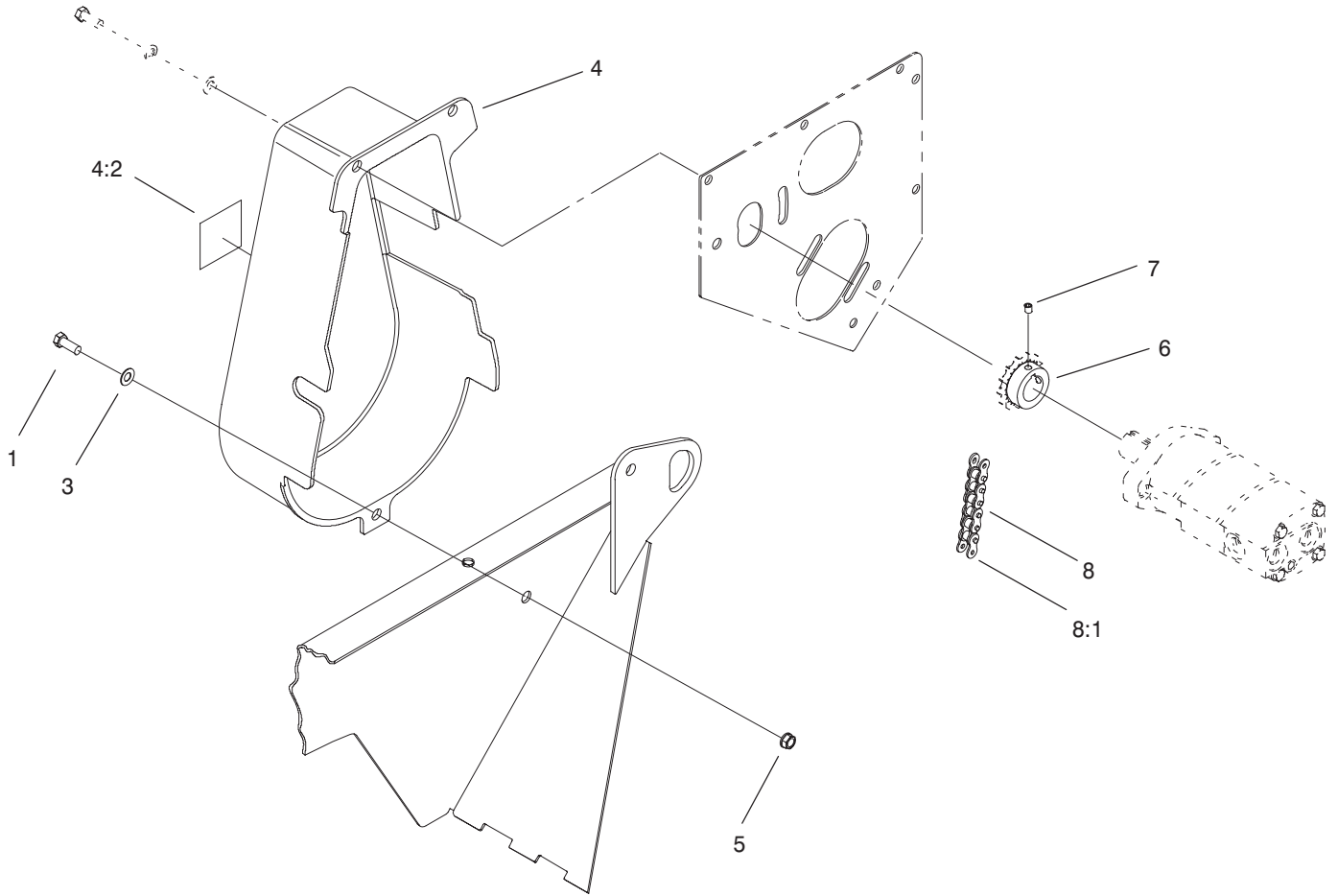

Sheet No.:11

Chain, Sprocket and Guard Assembly

Ref. No.	Part No.	Qty.	Description
1	3231-27	1	Screw-CARR
3	3256-24	1	Washer-Flat
4	105-0745	1	Guard-Chain
4:2	98-31 14	1	Decal-Warning, Belt Drive, Ce
5	3296-39	1	Nut-Lock, NI
6	99-0165-03	1	Sprocket-Drive
7	3246-3	2	Screw-HS
8	99-0164	1	Chain-Roller
8:1	2710-16	1	Link-Chain

Ref. No.	Part No.	Qty.	Description

Hydraulic Schematic

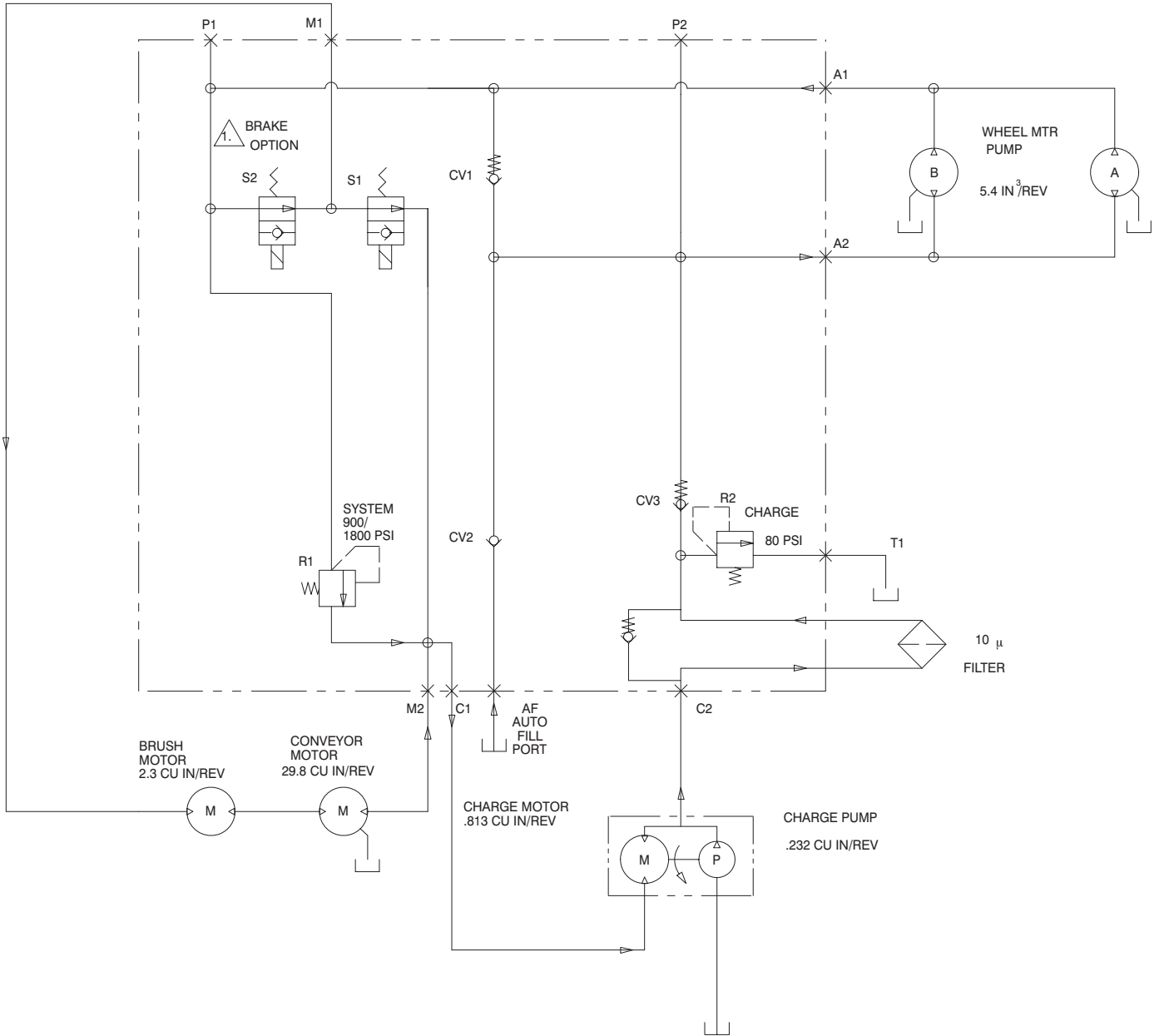

Electrical Schematic

