



Mid-Size Mower
ProLine Gear 12.5hp
with 36in Side Discharge Mower
Model No. 30193—230005001 and Up

Parts Catalog

Ordering Replacement Parts

To order replacement parts, please supply: the part number, the quantity, and the description of each part desired.

Understanding Reference Numbers

Each identified part in an illustration has a reference number. The reference number for a part also appears in the parts list, along with other information about the part.

This catalog uses two special reference number formats, one to indicate parts in a service assembly and another to indicate the quantity of a given part in an illustration.

Service Assembly Reference Numbers

Parts in service assemblies have reference numbers in the form **a:b**. The **a** represents the reference number of the entire service assembly and the **b** represents a sequential number unique to each part within the service assembly.

For example, a wheel assembly might be identified by reference number **6**, the tire by **6:1**, the valve by **6:2**, and the wheel by **6:3**. When you order the assembly identified by reference number **6**, you receive all parts identified by reference numbers **6:1**, **6:2**, and **6:3**. However, you may also order any part individually.

Reference numbers of this type appear in illustrations and in part lists.

Reference Numbers Indicating Quantity

In an illustration, if a reference number indicates more than one part, the reference number has the form **nX y**. The **n** represents the quantity of the part, the **X** is the multiplication symbol, and the **y** represents the reference number.

For example, in an illustration, the reference number **2X 37** means that two of the parts identified by reference number **37** are indicated.

Contents

Description	Page	Description	Page
Engine and Fuel System Assembly	3	Cooling Equipment Assembly	
Transmission and Drive Pulley Assembly	4	Kawasaki FB460V-MS14	16
Wheel Drive System Assembly	6	Electric Equipment Assembly	
Upper Handle Assembly	7	Kawasaki FB460V-MS14	17
Deck Assembly	8	Control Equipment Assembly	
Castor, Belt Tension and Blade Brake System		Kawasaki FB460V-MS14	18
Assembly	9	Carburetor Assembly	
Spindle, Blade and Belt Assembly	11	Kawasaki FB460V-MS14	19
Crankcase Assembly		Air Filter Assembly	
Kawasaki FB460V-MS14	12	Kawasaki FB460V-MS14	21
Piston/Crankshaft Crankcase Assembly		Starter Assembly	
Kawasaki FB460V-MS14	13	Kawasaki FB460V-MS14	22
Valve/Camshaft Assembly		Starter Assembly	
Kawasaki FB460V-MS14	14	Kawasaki FB460V-MS14	23
Lubrication Equipment Assembly		Muffler Assembly	
Kawasaki FB460V-MS14	15	Kawasaki FB460V-MS14	24

Accessories

Description	Model / Part No.	Description	Model / Part No.
Recycler Kit	30142	Atomic Blade	104-8590
Soft Bagger	30198	Low Lift Blade	103-2508

Part Description Abbreviations

Part descriptions in this catalog may include the following abbreviations.

Abbreviation	Meaning	Abbreviation	Meaning
AR	as required	HYD	hydraulic
ASM	assembly	INC	incorporated
CARR	carriage	LH	left hand
DEG	degrees	NI	nylon insert
FH	flat head	PPH	Phillips pan head
GA	gauge	PTH	Phillips truss head
HF	hex flange	PTO	power take off
HH	hex head	RH	right hand
HHF	hex head flange	SFH	slotted fillister head
HLH	hex lag head	SHH	slotted hex head
HJ	hex jam	SQH	square head
HOC	height-of-cut	SHWH	slotted hex washer head
HS	hex socket	SPH	slotted pan head
HSBH	hex socket button head	SRH	slotted round head
HSFH	hex socket flat head	STD	standard
HSH	hex socket head	TAP	self tapping
HWH	hex washer head	TTH	Torx truss head
HWHTF	hex washer head thread forming	WH	wing head

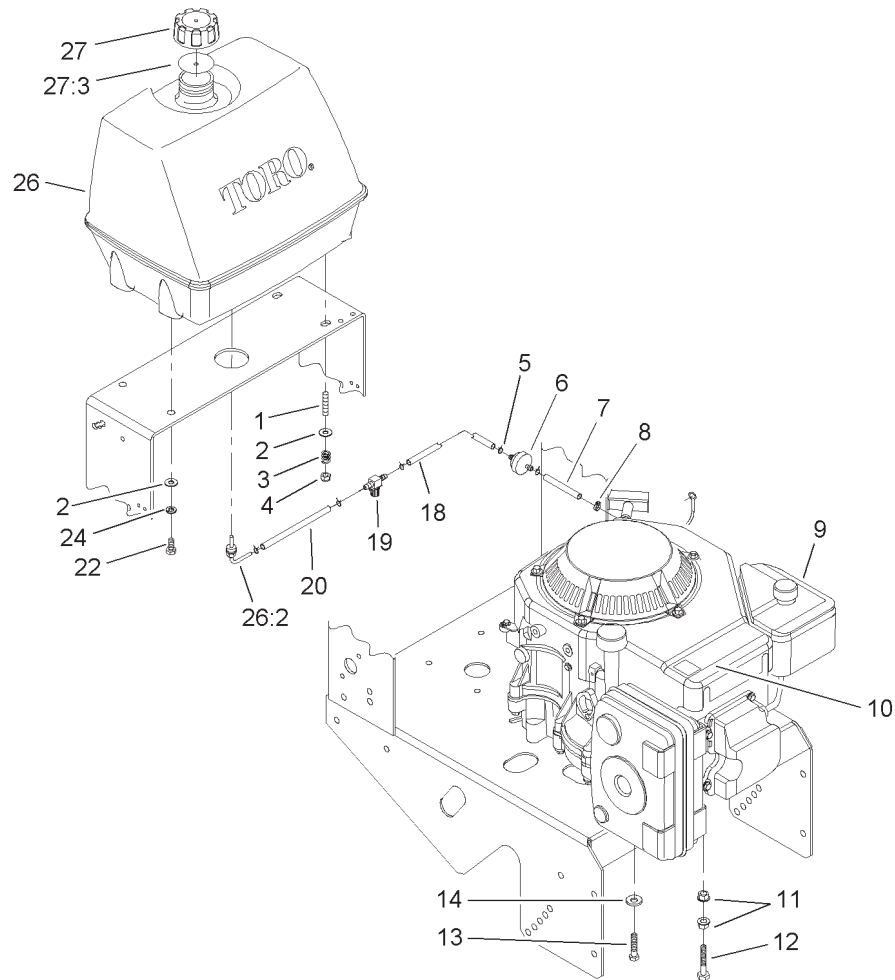

Sheet No.:2

Engine and Fuel System Assembly

Ref. No.	Part No.	Qty.	Description	Ref. No.	Part No.	Qty.	Description
1	1-633023	2	Stud	*99	1-303287	1	Tie-Plastic
2	3256-23	4	Washer-Flat	*99	1-303335	1	Tie-Plastic
3	1-633349	2	Spring-Tank, Fuel				
4	3296-47	2	Nut-Lock, NI				
5	1-303077	5	Clamp				
6	1-303197	1	Filter-Fuel				
7	103-2944	1	Line-Fuel				
8	1-303308	1	Clamp-Hose				
☆9		1	Engine-Kawasaki, Fb460v-Ms14				
10	106-0699	1	Decal-W arning, Hot Surfaces				
11	3290-357	2	Nut-HHF				
12	323-13	1	Screw-HH				
13	33114-025	4	Screw-HH				
14	1-303334	4	Washer-Spring				
18	1-303022	1	Hose-Fuel				
19	1-603770	1	Valve-Fuel				
20	1-603955	1	Hose-Fuel				
22	322-3	2	Screw-HH				
24	1-805005	2	Washer-Lock				
26	106-0730	1	Fuel Tank ASM				
26:2	103-2605	1	Fitting-Fuel, Bulkhead				
27	88-3980	1	Gas Cap ASM				
27:3	88-4010	1	Gasket-Cap, Gas				

* Not illustrated

☆ Not serviced separately

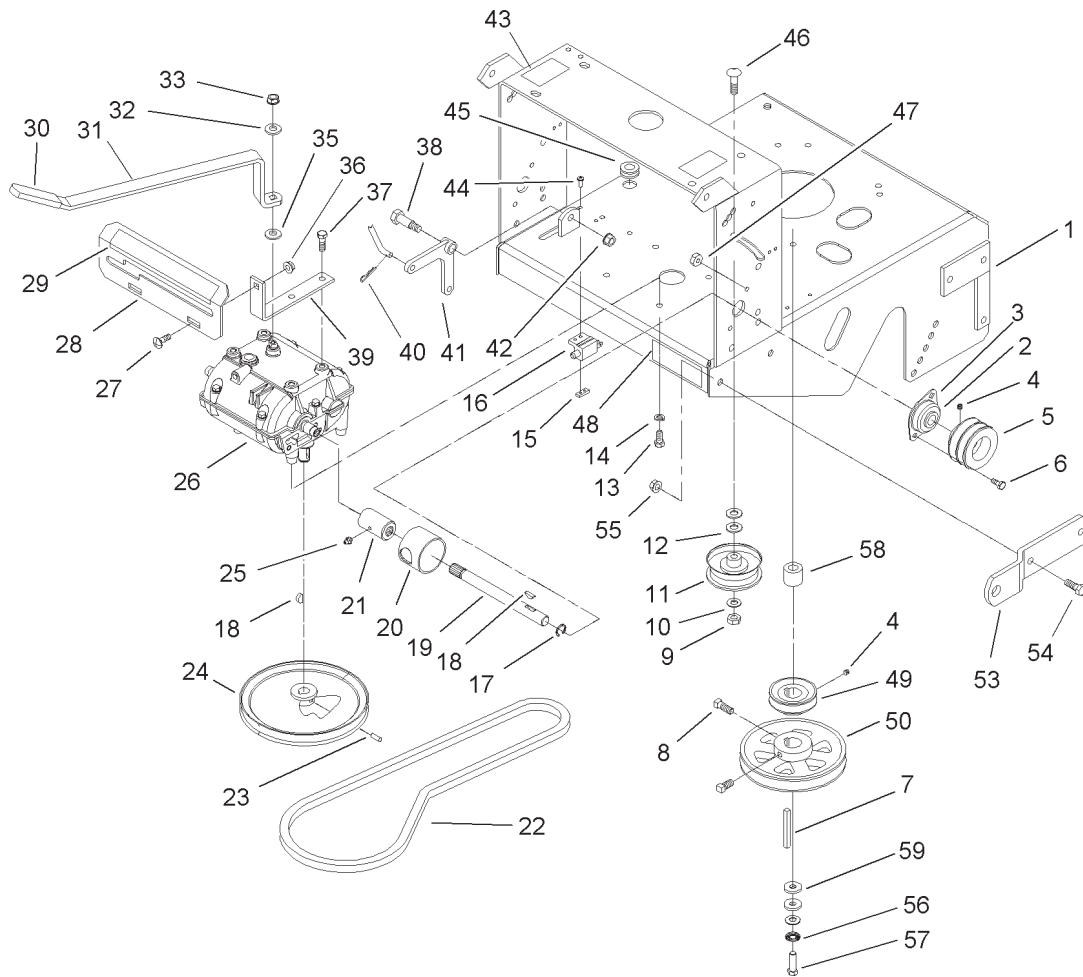

Sheet No.:3

Transmission and Drive Pulley Assembly

Ref. No.	Part No.	Qty.	Description
1	103-2923-01	1	Deck-Rear
2	1-323252	2	Bearing-Shaft
3	1-323254	2	Flange-Output
4	1-803310	3	Screw-Set
5	1-323257-03	2	Sheave-T ransmission
6	321-3	4	Screw-HH
7	103-4177	1	Key-Square
8	3242-4	2	Screw-Set, SQH
9	3296-39	1	Nut-Lock, NI
10	3256-24	1	Washer-Flat
11	1-323285	1	Idler-Drive, Transmission
12	3256-5	2	Washer-Flat
13	322-3	4	Screw-HH
14	1-805005	4	Washer-Lock
15	1-633181	1	Plate-Tapped
16	1-513152	1	Switch-Closed, Normally
17	32151-62	2	Ring-Retaining
18	3257-5	3	Key-W oodruff
19	1-323502	2	Shaft-T ransmission
20	51-4220	2	Guard-Coupler
21	1-323680	2	Coupler
22	1-323630	1	V-Belt
23	3245-41	2	Screw-HSH
24	1-323278	1	Sheave-T ransmission

Ref. No.	Part No.	Qty.	Description
25	302-19	2	Fitting-Grease
26	1-323500	1	Transmission
27	3230-1	2	Bolt-CARR
28	1-323387-03	1	Plate-Shift
29	98-3256	1	Decal-Speed, Ground
30	1-303020	1	Grip-Lever
31	98-3274-03	1	Lever-Shift
32	98-5975	1	Washer-Belleville
33	3296-6	1	Nut-Lock, NI
35	1-323379	1	Washer
36	32128-20	2	Nut-HF
37	9264964	4	Screw
38	1-603403	1	Bolt-Shoulder
39	1-323389-03	2	Bracket-Plate, Shift
40	1-806003	1	Pin-Hair
41	1-303186	1	Bellcrank
42	3290-357	1	Nut-HHF
43	95-2814	1	Decal-Shut Off, Fuel
44	3290-500	2	Screw-PPH
45	1-543296	1	Grommet
46	3231-6	1	Screw-CARR
47	3296-42	4	Nut-Lock, NI
48	98-0776	1	Decal-Caution
49	1-323256	1	Sheave-T ransmission
50	1-643292	1	Sheave-Split
53	1-323318-01	2	Hitch-Sulky

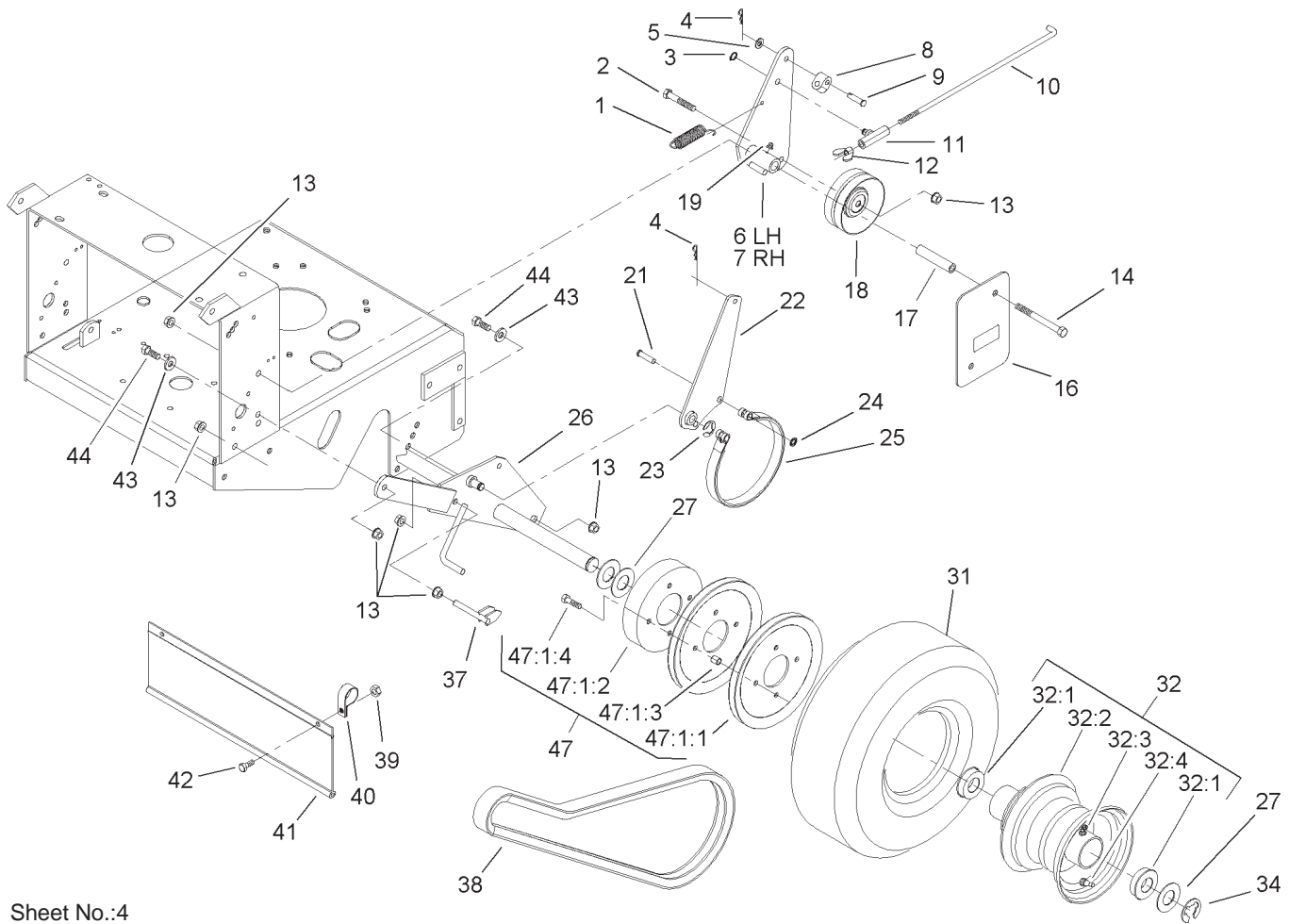

Sheet No.:4

Wheel Drive System Assembly

Ref. No.	Part No.	Qty.	Description
1	98-3273	2	Spring-Extension
2	323-10	2	Screw-HH
3	32151-47	2	Ring-Retaining
4	1-806003	4	Pin-Hair
5	3256-23	2	Washer-Flat
6	104-1321-03	1	RH Idler Arm ASM
7	104-1322-03	1	LH Idler Arm ASM
8	74-0521	2	Fitting-Rod
9	283-6	2	Pin-Clevis
10	1-323296	2	Rod-Brake
11	1-322125	2	Swivel-Brake
12	1-513959	2	Wingnut-Nylock
13	3290-357	14	Nut-HHF
14	323-16	4	Screw-HH
16	98-5131-01	2	Shield-Wheel, Drive
17	1-323694	4	Spacer-Shield
18	1-323634	2	Idler-Drive, Wheel
19	302-19	2	Fitting-Grease
21	1-323307	4	Pin-Clevis
22	1-322209-03	2	Arm-Brake
23	32120-47	2	Ring-Retaining, External
24	1-803051	4	Nut-Push
25	1-323595	2	Band-Brake
26	1-322212-03	1	Axle ASM
27	1-523157	6	Washer-Spacer

Ref. No.	Part No.	Qty.	Description
27	1-543436	8	Washer-Spacer
31	1-323720	2	Tire-T urfmaster
32	1-323328	2	Wheel And Hub ASM
32:1	1-323329	2	Bearing-Flanged
☆32:2		1	Rim ASM
☆32:3		1	Fitting-Grease
☆32:4		1	Stem-V alve
34	1-808519	2	Ring-Snap
37	1-412358	2	Scraper
38	1-323631	2	V-Belt
39	3296-29	2	Nut-Lock, NI
40	2412-104	2	R-Clamp
41	98-3259	1	Shield-T railing
42	322-3	2	Screw-HH
43	98-5975	4	Washer-Belleville
44	323-6	4	Screw-HH
☆47		2	Drive Wheel ASM
47:1:1	1-323253	2	Sheave-Wheel, Drive
47:1:2	1-323261	1	Drum-Brake
47:1:3	1-323260	4	Spacer-Sheave, Wheel
47:1:4	322-6	4	Screw-HH

☆ Not serviced separately

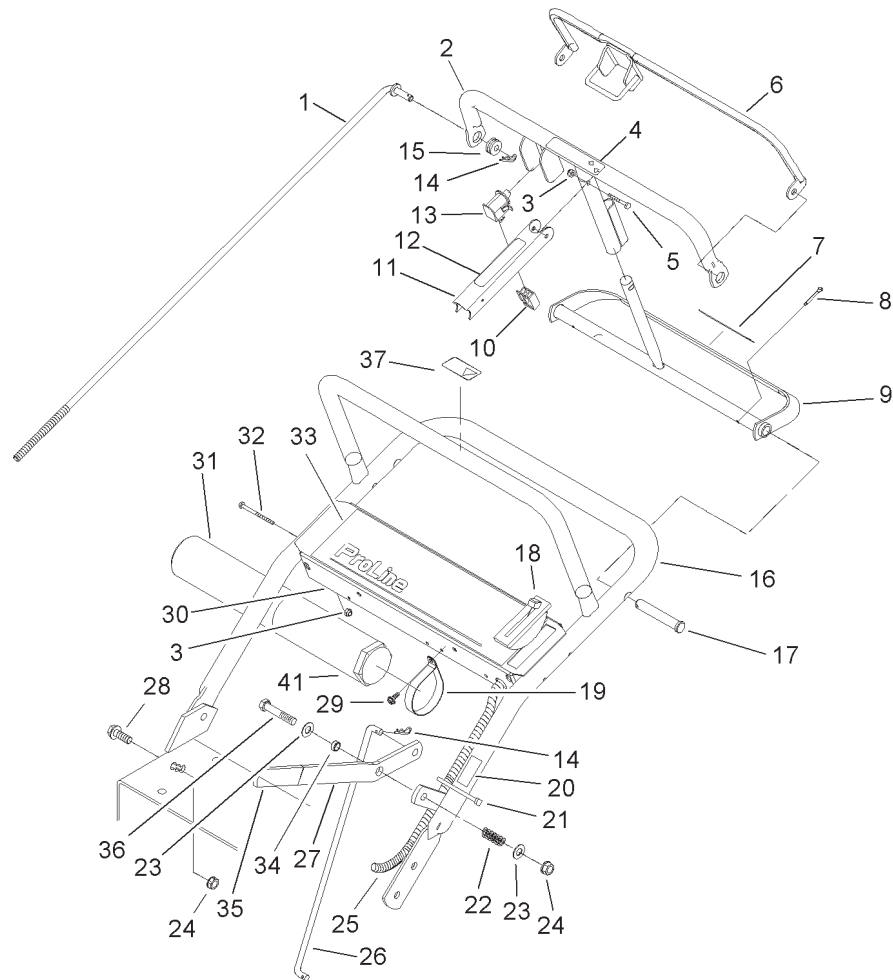

Sheet No.:5

Upper Handle Assembly

Ref. No.	Part No.	Qty.	Description	Ref. No.	Part No.	Qty.	Description
1	98-3282	2	Rod-Control	27	98-3287-03	1	Lever-Engagement, Blade
2	95-5522-03	1	Control Bar ASM	28	323-6	4	Screw-HH
3	3296-2	5	Nut-Lock	29	32104-76	2	Screw
4	82-2290	1	Decal	30	1-304259	1	Panel-Control
5	32105-1	1	Screw-SHH	31	104-7050	1	Housing-Manual
6	98-3289-03	1	Bail ASM	32	32105-14	4	Screw
7	82-2280	1	Decal	33	106-0709	1	Decal
8	3272-1 1	2	Pin-Cotter	34	99-8509	1	Spacer
9	99-8501-03	1	Control-Pivot	35	1-303020	1	Grip-Lever
10	218-595	1	Connector-Body	36	323-10	1	Screw-HH
11	98-3261-03	1	Lever-Brake, Parking	37	98-4387	1	Decal-Protection, Ear
12	98-3266	1	Decal	41	104-7048	1	Cap-Housing
13	740275	1	Switch-Seat				
14	1-806003	4	Pin-Hair				
15	237-141	2	Grommet-Rubber				
16	98-3267-03	1	Upper Handle ASM				
17	283-55	2	Pin-Clevis				
18	1-323637	1	Cable-Throttle				
19	2412-120	2	R-Clamp				
20	95-5537	1	Decal				
21	1-303335	1	Tie-Plastic				
22	1-303160	1	Spring-Compression				
23	3256-24	2	Washer-Flat				
24	3296-39	5	Nut-Lock, NI				
25	98-3257	1	Harness-Wire				
26	98-3279	1	Linkage-Drive, Blade				

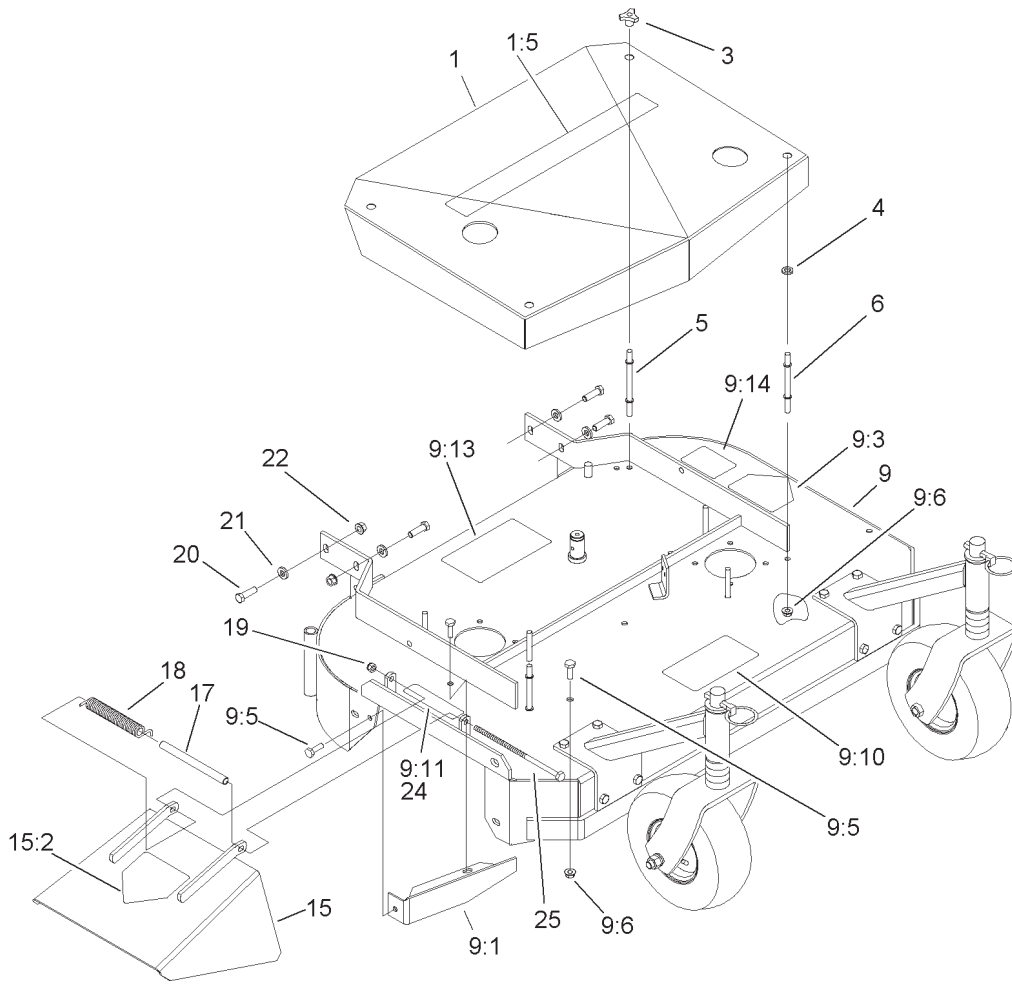

Sheet No.:6

Deck Assembly

Ref. No.	Part No.	Qty.	Description
1	1-304258	1	Belt Shield ASM
1:5	106-071 1	1	Decal
3	1-323385	4	Knob-3 Prong
4	1-323417	4	Washer
5	1-303536	2	Stud-Shield, Belt (Long)
6	1-303537	2	Stud-Shield, Belt (Short)
9	105-4680	1	Deck ASM
9:1	1-302189-01	1	Baffle
9:3	1-403005	1	Decal-Danger
9:5	322-2	8	Screw-HH
9:6	32128-20	8	Nut-HF
9:10	66-1340	1	Decal-Danger
9:11	98-5954	1	Decal-Missing, Cover
9:13	98-3296	1	Decal
9:14	98-5130	1	Decal
15	1-304256	1	Chute-Discharge
15:2	54-9220	1	Decal-Danger
17	98-3281	1	Spacer-Spring
18	98-3280	1	Spring-Deflector
19	3296-29	1	Nut-Lock, NI
20	323-8	6	Screw-HH
21	98-5975	6	Washer-Belleville
22	3290-357	6	Nut-HHF

Ref. No.	Part No.	Qty.	Description
24	67-5360	1	Decal-Danger
25	322-50	1	Screw-HH

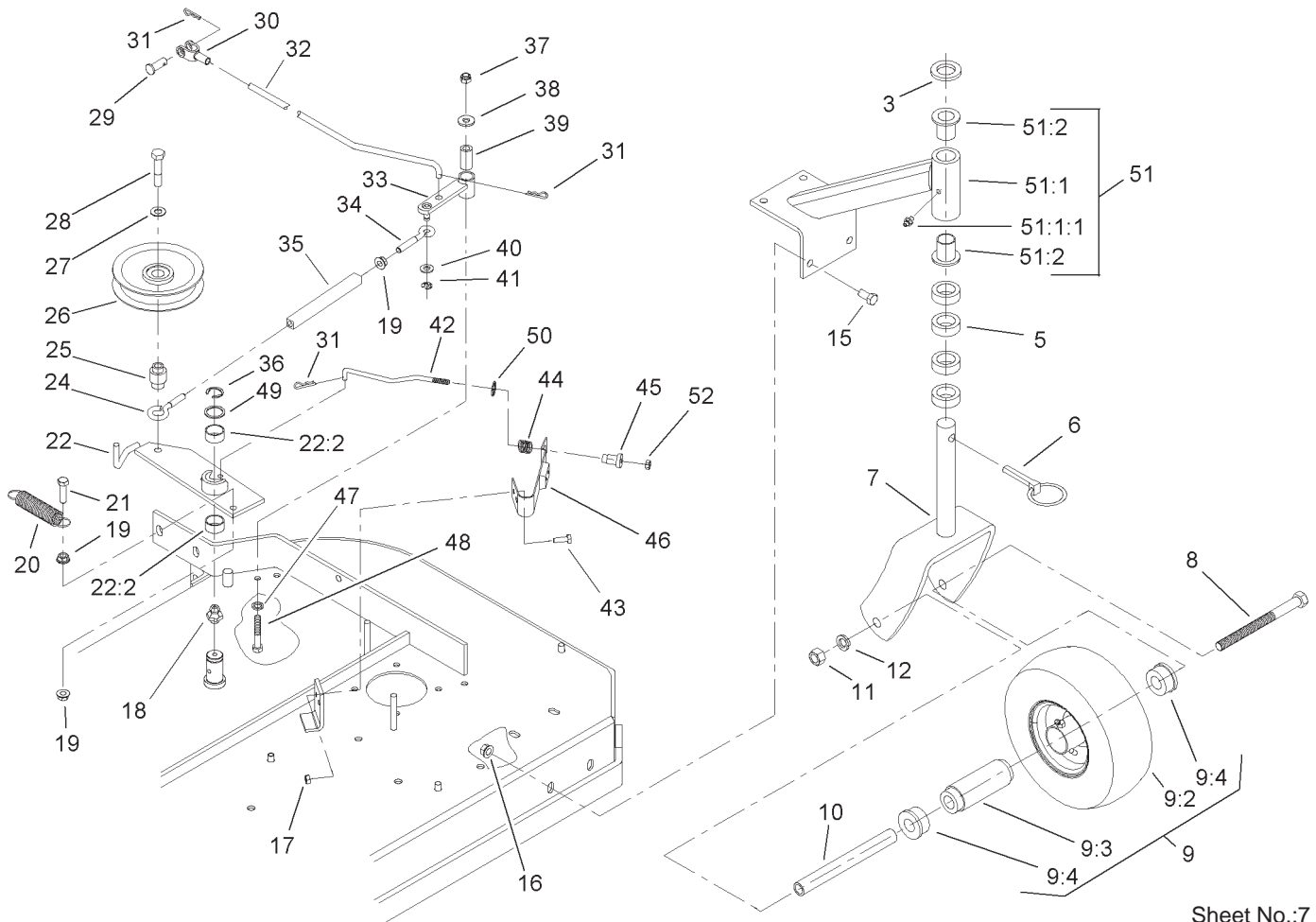

Sheet No.:7

Castor, Belt Tension and Blade Brake System Assembly

Ref. No.	Part No.	Qty.	Description
3	1-513338	2	Washer-Flat
5	1-303314	8	Spacer-Caster
6	1-809020	2	Pin
7	1-322145-01	2	Fork
8	325-20	2	Screw-HH
9	1-513648	2	Wheel And Tire ASM
9:2	1-513808	1	Tire
9:3	1-513809	1	Bearing
9:4	1-513810	2	Bushing
10	1-513547	2	Spacer
11	3217-9	2	Nut-Hex
12	3253-7	2	Washer-Lock
15	323-4	8	Screw-HH
16	3290-357	8	Nut-HHF
17	3296-42	2	Nut-Lock, NI
18	302-19	1	Fitting-Grease
19	32128-20	3	Nut-HF
20	1-323071	1	Spring-Extension
21	322-6	1	Screw-HH
22	103-3600	1	Idler Arm ASM
22:2	1-323729	2	Sleeve-Bearing
24	1-303348	1	Eyebolt-Thread, LH
25	1-303434	1	Bushing-Engagement
26	1-603843	1	Pulley-Idler
27	98-5975	1	Washer-Belleville
28	702809	1	Screw-Cap

Ref. No.	Part No.	Qty.	Description
29	1-808280	1	Pin-Clevis
30	1-303105	1	Yoke-Adjustable
31	1-806003	3	Pin-Hair
32	1-323303	1	Linkage-Arm
33	1-322235	1	Arm-Assist
34	1-303238	1	Eyebolt-Thread, RH
35	1-303236	1	Body-T urnbuckle
36	32151-103	1	Ring-Snap
37	3296-29	1	Nut-Lock, NI
38	3256-3	1	Washer-Flat
39	1-403179	1	Tube-Pivot
40	3256-23	1	Washer-Flat
41	32120-35	1	E-Ring
42	1-323715	1	Rod-Brake
43	321-4	2	Screw-HH
44	1-323747	1	Spring-Compression
45	1-323746	1	Spacer-Flanged
46	1-324372	1	Pad/Spring ASM
47	1-303334	1	Washer-Spring
48	322-10	1	Screw-HH
49	1-303352	1	Washer-Spindle
50	1-323748	1	Ring-Push On
51	1-302203	2	Support ASM
☆51:1		1	Support-Caster
51:1:1	302-52	1	Fitting-Grease

☆ Not serviced separately

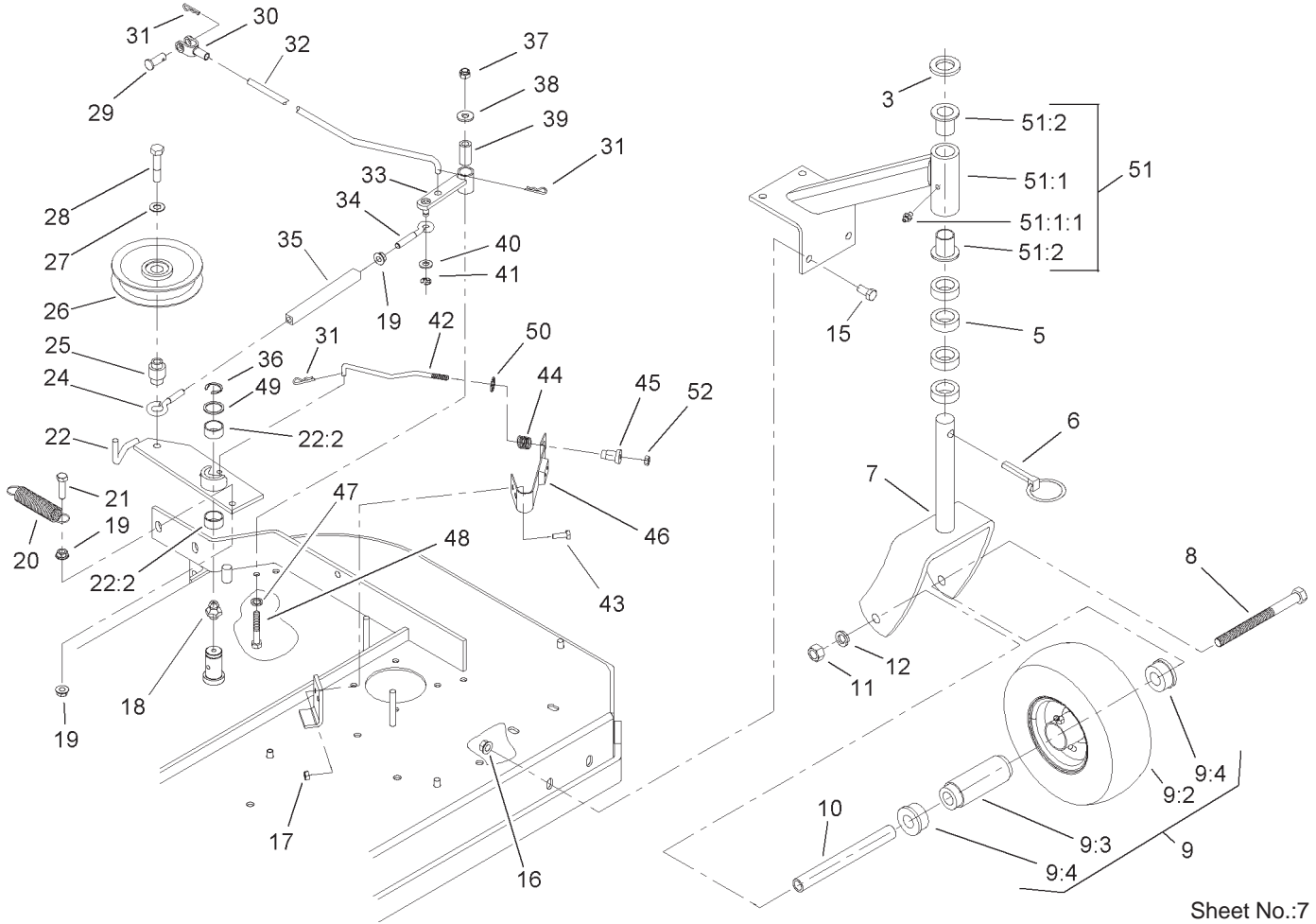

Sheet No.:7

Castor, Belt Tension and Blade Brake System Assembly (Continued)

Ref. No.	Part No.	Qty.	Description
51:2	1-303514	2	Bearing-Flanged
52	3296-56	1	Nut-Lock, NI

Ref. No.	Part No.	Qty.	Description

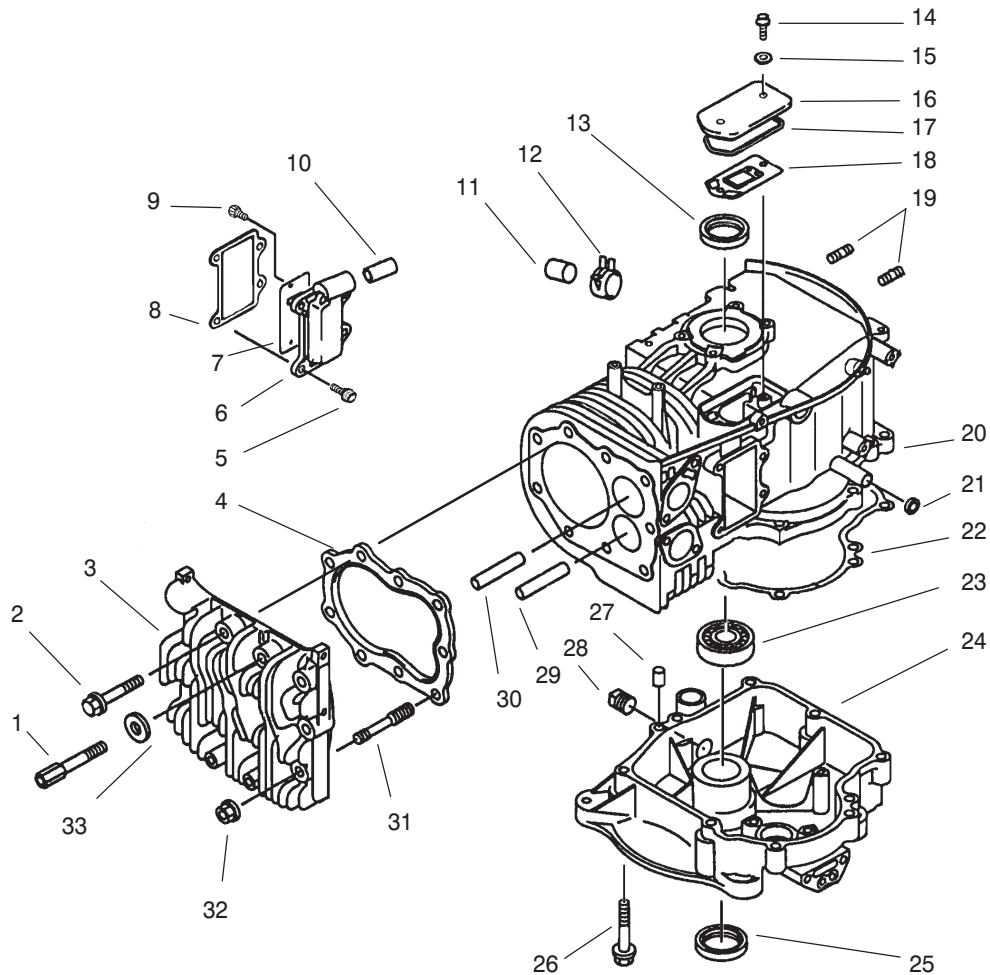

Crankcase Assembly Kawasaki FB460V-MS14

Ref. No.	Part No.	Qty.	Description
1	92002-2258	2	Bolt
2	130g1055	4	Bolt-Flange
3	11001-2151	1	Head-Cylinder
4	11004-2091	1	Gasket-Head
5	130g0616	4	Bolt-Flange
6	49108-2011	1	Cover-V alve Chamber
7	14025-2143	1	Cover
8	11060-2375	1	Gasket
9	92009-2307	2	Screw
10	92059-2142	1	Tube
11	92066-2096	1	Plug
12	92170-2088	1	Clamp
13	92049-2096	1	Seal-Oil
14	92002-2087	2	Bolt
15	11060-2323	2	Gasket
16	14025-2040	1	Cover-Breather
17	11009-2339	1	Gasket-Cover
18	14069-2062	1	Breather
19	92004-2083	4	Stud-6 X 14
20	49120-6108	1	Crankcase-Complete
21	92049-2097	1	Seal-Oil
22	11060-2015	1	Gasket-Crankcase
23	601a6207	1	Bearing-Ball
24	49015-6176	1	Cover-Crankcase

Ref. No.	Part No.	Qty.	Description
25	92049-2227	1	Seal-Oil
26	130g0845	8	Bolt-Flange
27	92043-1263	2	Pin
28	92066-2097	1	Plug
29	49002-2071	1	Guide-V alve Exhaust
30	49002-2070	1	Guide-V alve Intake
31	92004-2082	3	Stud
32	92015-2115	3	Nut
33	410b1000	2	Washer-Plain

Obtain Parts from Kawasaki

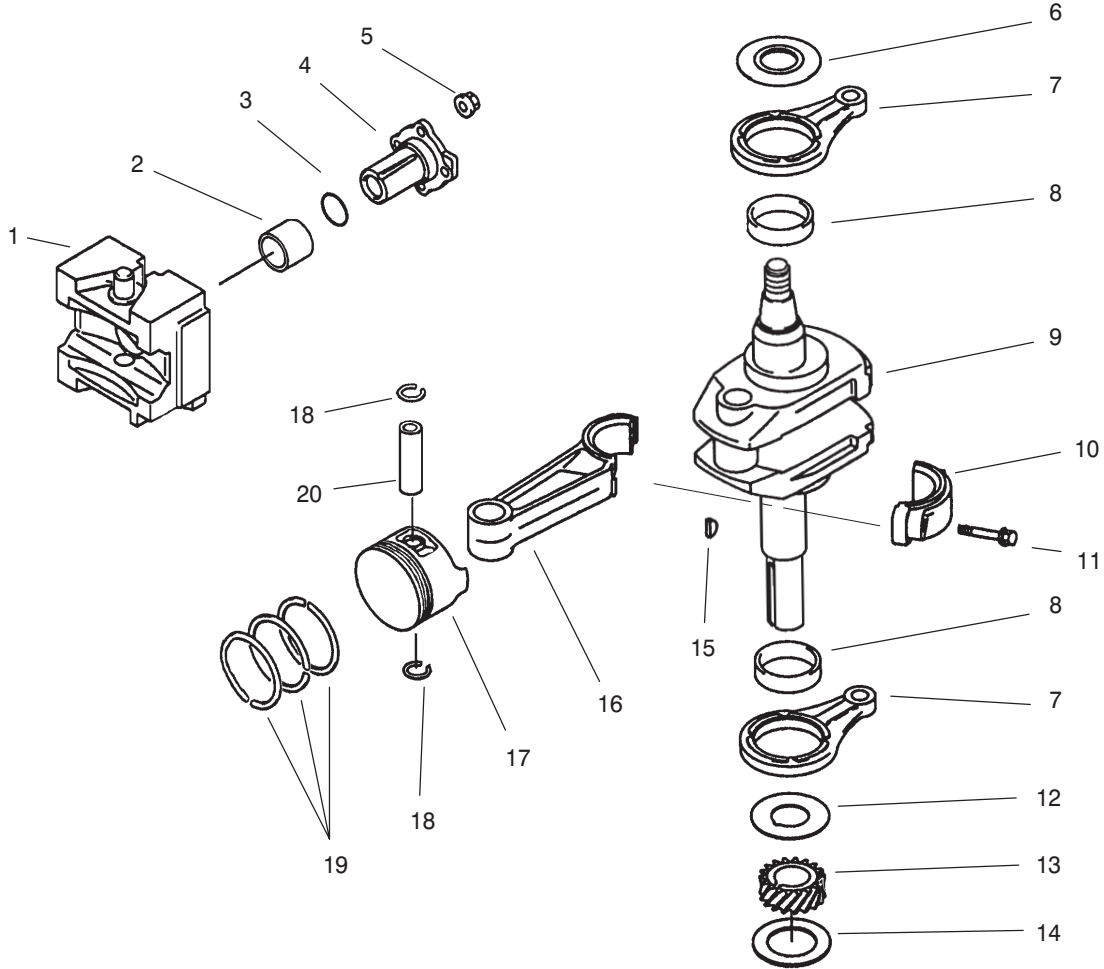

Piston/Crankshaft Crankcase Assembly Kawasaki FB460V-MS14

Ref. No.	Part No.	Qty.	Description
1	13042-6006	1	Weight Incl #2
2	92141-2097	1	Bearing-Plane
3	92055-2072	1	O-Ring
4	13107-2253	1	Shaft
5	92015-1 193	4	Nut
6	92026-2164	1	Spacer
7	46102-6007	2	Rod Incl #8
8	92141-2108	2	Bearing-Plane
9	49119-2177	1	Crankshaft ASM
11	92150-2193	2	Bolt
12	92026-2156	1	Spacer
13	59056-2105	1	Gear-Helical
14	92025-2145	A/R	Shim T=1.18
14	92025-2146	A/R	Shim T=1.25
14	92025-2147	A/R	Shim T=1.32
14	92025-2148	A/R	Shim T=1.39
14	92025-2149	A/R	Shim T=1.46
14	92025-2150	A/R	Shim T=1.53
14	92025-2151	A/R	Shim T=1.60
14	92025-2152	A/R	Shim T=1.67
14	92025-2153	A/R	Shim T=1.74
14	92180-2015	A/R	Shim T=1.11
14	92180-2016	A/R	Shim T=1.81
15	92038-2094	1	Key

Ref. No.	Part No.	Qty.	Description
16	13251-6005	1	Rod ASM Incl #10 11
16	13251-6007	A/R	Rod ASM Incl #10 11 0.50
17	13001-2096	1	Piston
17	13029-2084	A/R	Piston 0.25
17	13029-2085	A/R	Piston 0.50
18	92033-2176	2	Ring-Snap
19	13008-6009	1	Set-Ring Piston
19	13008-6010	A/R	Set-Ring Piston 0.25
19	13008-6011	A/R	Set-Ring Piston 0.50
20	13002-2066	1	Pin-Piston

Obtain Parts from Kawasaki

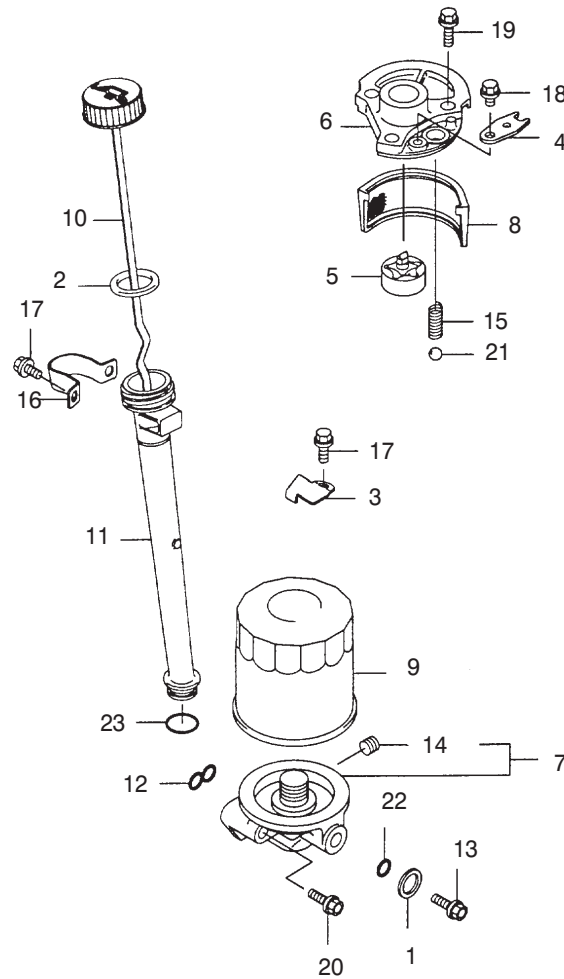

Lubrication Equipment Assembly Kawasaki FB460V-MS14

Ref. No.	Part No.	Qty.	Description	Ref. No.	Part No.	Qty.	Description
1	11009-2175	1	Gasket				
2	11009-2346	1	Gasket-Oil Gauge				
3	13169-2359	1	Plate				
4	13270-2054	1	Plate				
5	16082-2057	1	Pump Assy-Oil				
6	16142-6001	1	Cover-Pump				
7	23062-6001	1	Bracket-Comp				
8	49065-2056	1	Filter-Oil				
9	49065-2071	1	Filter-Oil				
10	52005-2058	1	Gauge-Oil				
11	59231-2059	1	Filler				
12	92055-2063	1	Ring-O				
13	92066-2093	1	Plug				
14	92066-2211	1	Plug				
15	92081-2216	1	Spring				
16	92170-2014-9H	1	Clamp				
17	130B0508	3	Bolt-Flanged				
18	130B610	1	Bolt-Flanged				
19	130G0825	3	Bolt-Flanged				
20	130G0845	2	Bolt-Flanged				
21	600A1000	1	Ball-Steel				
22	670D1507	1	O Ring				
23	670D2016	1	O Ring				

Obtain Parts from Kawasaki

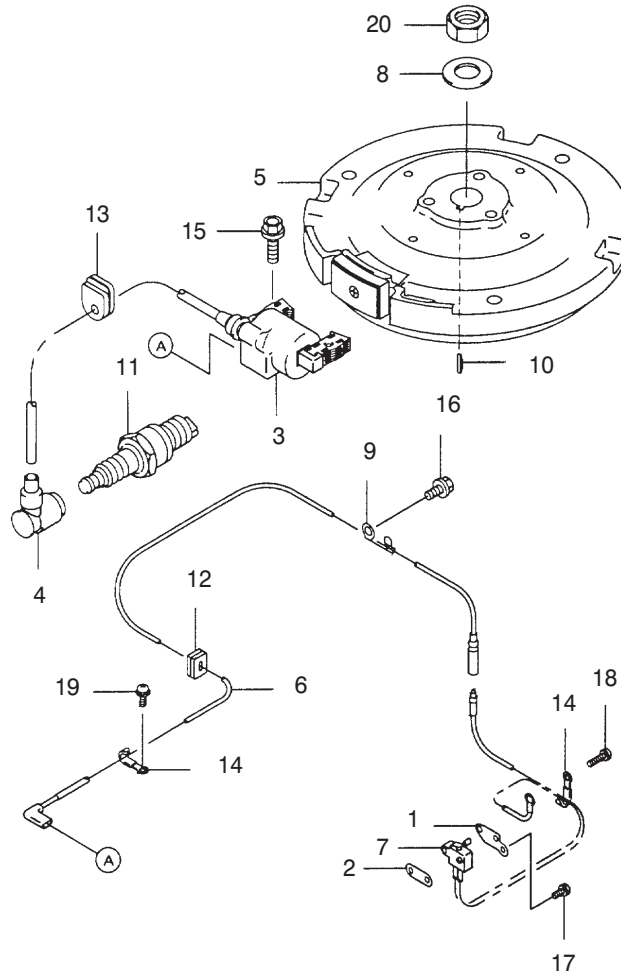

Electric Equipment Assembly Kawasaki FB460V-MS14

Ref. No.	Part No.	Qty.	Description
1	13183-2373	1	Plate
2	13183-2374	1	Plate
3	21121-2086	1	Coil-Ignition
4	21130-2060	1	Cap-Spark Plug
5	21194-2324	1	Flywheel-Comp
6	26011-2326	1	Wire-Lead L530
7	27010-2167	1	Switch
8	92022-2178	1	Washer
9	92037-2011	1	Clamp
10	92038-2094	1	Key
11	92070-2105	1	Plug-Spark BMR4A (NGK)
12	92071-2099	1	Grommet
13	92071-2100	1	Grommet
14	92170-2029	2	Clamp
15	130B0520	2	Bolt-Flanged
16	130B0610	1	Bolt-Flanged
17	223B0410	1	Screw-Pan Ws Cros
18	233B0416	1	Screw-Pan Ws Cros
19	234B0408	1	Screw-Pan Wsp
20	314G1800	1	Nut-Hex Fine

Ref. No.	Part No.	Qty.	Description

Obtain Parts from Kawasaki

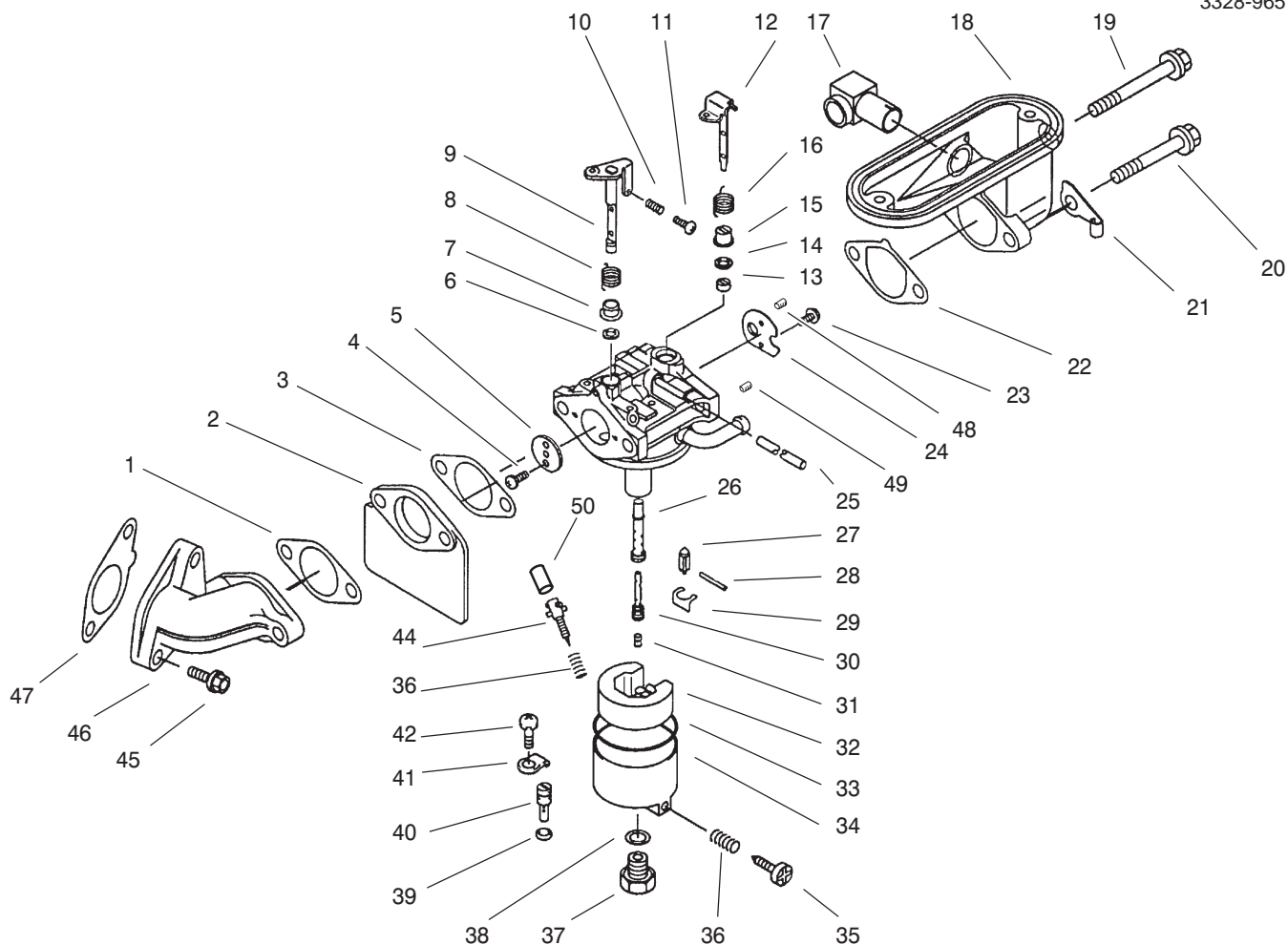

Carburetor Assembly Kawasaki FB460V-MS14

Ref. No.	Part No.	Qty.	Description	Ref. No.	Part No.	Qty.	Description
0	15003-2467	1	Carburetor ASM	24	16126-2206	1	Valve-Choke
1	11060-2338	1	Gasket-Intake Pipe	25	92059-2266	1	Tube
2	16073-2091	1	Insulator	26	49121-2207	1	Nozzle-Main #98A
3	11060-2339	2	Gasket-Carburetor	27	16030-2073	1	Valve-Float
4	92009-2080	2	Screw	28	92043-2006	1	Pin
5	16025-2141	1	Valve-Throttle #110	29	92033-2067	1	Ring-Snap
6	92093-2082	1	Seal	30	49123-2078	1	Holder-Main Jet
7	92027-2025	1	Collar	31	92063-2294	1	Jet-Main
8	92081-2077	1	Spring	32	16031-2066	1	Float
9	16041-2009	1	Shaft-Throttle	33	11009-2024	1	Gasket
10	92081-2046	1	Spring	34	16020-2109	1	Chamber-Float Incl 35 and 36
11	92009-2079	1	Screw	35	92009-2015	1	Screw
12	16041-2010	1	Shaft-Choke	36	92081-2009	2	Spring
13	92027-2003	1	Collar	37	92150-2146	1	Bolt
14	92093-2069	1	Seal	38	11009-2025	1	Gasket
15	92143-2142	1	Collar	39	16038-024	1	Gasket
16	92144-2160	1	Spring	40	92064-2108	1	Jet-Pilot
17	59071-2062	1	Joint	41	13183-2252	1	Plate
18	16060-2108	1	Pipe-Intake	42	92009-2244	1	Screw
19	92002-2254	1	Bolt	44	16014-2076	1	Screw-Pilot Air
20	92002-2253	1	Bolt	45	130g0825	2	Bolt-Flange
21	92170-2019	1	Clamp	46	16060-2109	1	Pipe-Intake
22	11060-2338	1	Gasket	47	11060-2337	1	Gasket-Intake Pipe
23	92009-2081	2	Screw				

Obtain Parts from Kawasaki

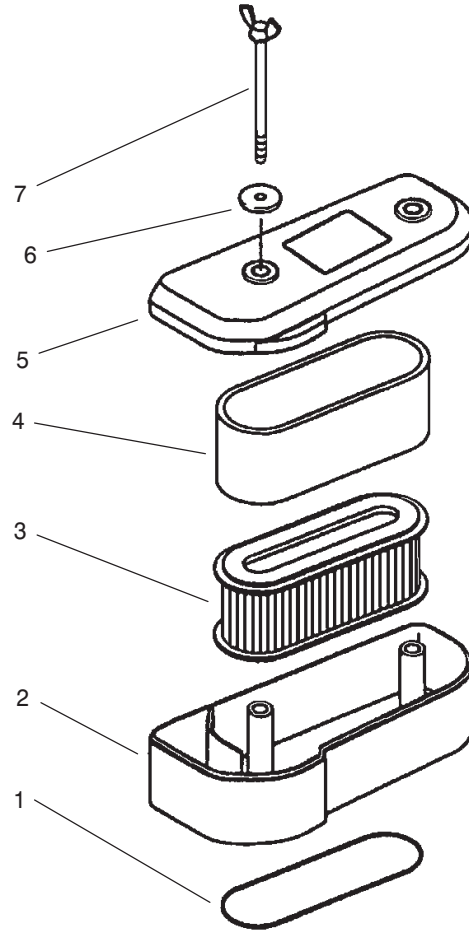

Air Filter Assembly Kawasaki FB460V-MS14

Ref. No.	Part No.	Qty.	Description		Ref. No.	Part No.	Qty.	Description
1	11009-2443	1	Gasket-Air Filter					
2	11011-2174	1	Case-Air Filter					
3	11013-2021	1	Element-Air Filter					
4	11013-2020	1	Element-Air Filter					
5	11012-2192	1	Cap-Air Filter					
6	92022-2220	2	Washer					
7	92002-2230	2	Bolt					
	11010-2291	1	Filter ASM					

Obtain Parts from Kawasaki

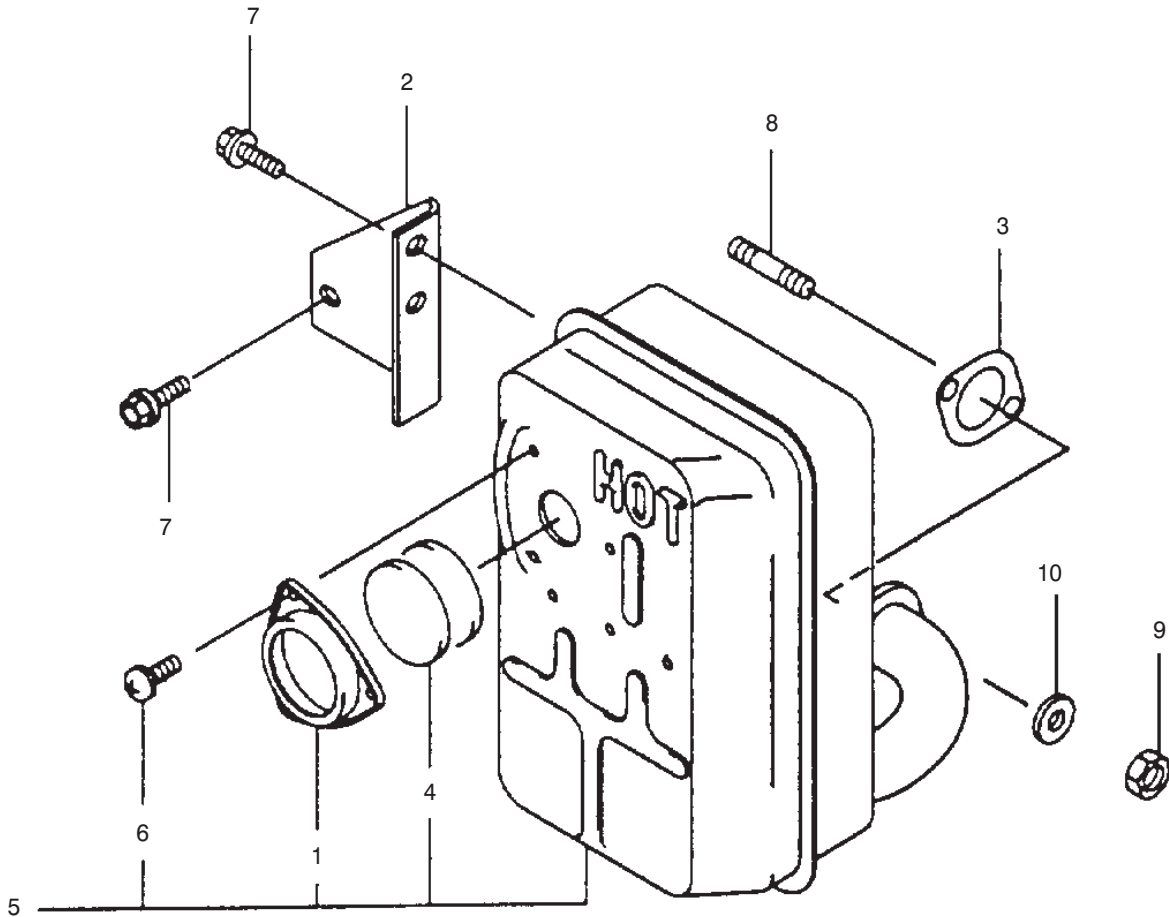

Muffler Assembly Kawasaki FB460V-MS14

Ref. No.	Part No.	Qty.	Description
1	11012-2251-9Y	1	Cap-Spark Arrester
2	11046-2163-9Y	1	Bracket
3	11060-2379	1	Gasket
4	18077-2052	2	Arrester-Spark
5	49069-2210-9Y	1	Muffler Assembly
6	92009-2166	3	Screw
7	130G0812	4	Bolt-Flanged
8	171G0818	2	Bolt-Stud
9	317R0800	2	Nut-Hex Small
10	461F0800	2	Washer-Spring

Ref. No.	Part No.	Qty.	Description

Obtain Parts from Kawasaki

