



**Count on it.**

**Parts Catalog**

**Front Tine Tiller**

Model No. 58602—Serial No. 323000001 and Up



# Ordering Replacement Parts

To order replacement parts, please supply the part number, the quantity, and the description of each part desired.

## Understanding Reference Numbers

Each identified part in an illustration has a reference number. The reference number for a part also appears in the parts list, along with other information about the part.

This catalog uses two special reference number formats, one to indicate parts in a service assembly and another to indicate the quantity of a given part in an illustration.

## Service Assembly Reference Numbers

Parts in service assemblies have reference numbers in the form a:b. The a represents the reference number of the entire service assembly and the b represents a sequential number unique to each part within the service assembly.

For example, a wheel assembly might be identified by reference number 6, the tire by 6:1, the valve by 6:2, and the wheel by 6:3. When you order the assembly identified by reference number 6, you receive all parts identified by reference numbers 6:1, 6:2, and 6:3. However, you may also order any part individually. Reference numbers of this type appear in illustration and in parts lists.

## Reference Numbers Indicating Quantity

In an illustration, if a reference number indicates more than one part, the reference number has the form nX y. The n represents the quantity of the part, the X is the multiplication symbol, and the y represents the reference number.

For example, in an illustration, the reference number 2X 37 means that two of the parts identified by reference number 37 are indicated.

# Contents

Chassis and Wheels Assembly ..... 4  
Tines and Transmission Assembly ..... 6  
Handles and Controls Assembly ..... 8

# Chassis and Wheels Assembly

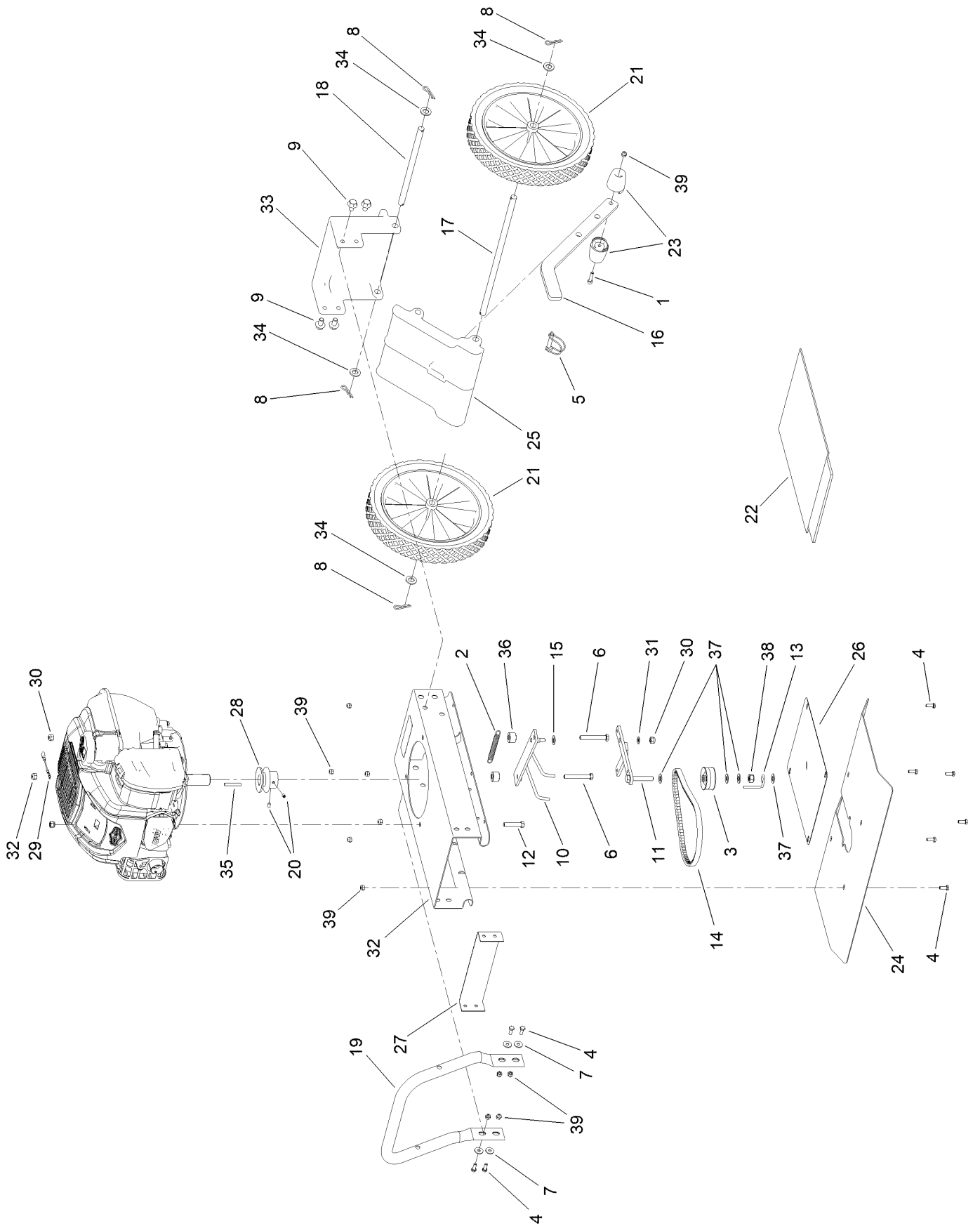

## Chassis and Wheels Assembly (continued)

<i>Ref.</i>	<i>Part Number</i>	<i>Qty.</i>	<i>Description</i>	<i>Ref.</i>	<i>Part Number</i>	<i>Qty.</i>	<i>Description</i>
1	144-4878	1	Screw-SHCS	21	144-5005	2	Wheel-Grey
2	144-4977	1	Spring-Extension	22	144-5006	1	Bag-Manual
3	144-4978	1	Pulley-Idler	23	144-4946	2	Handle
4	144-4981	10	Screw-HHCS	24	144-5007	1	Shield-Tine
5	144-4685	1	Pin-Clevis, Locking	25	144-5008	1	Tail Mount-Lower
6	144-4988	2	Screw-HHCS	26	144-5009	1	Shield-Rear
7	144-4989	4	Washer-Flat	27	144-5010	1	Cover-Front
8	144-4990	4	Pin-Cotter	28	144-5011	1	Pulley-Engine
9	144-4992	4	Screw-HHSF	29	144-5013	1	Wire-Ground
10	144-4994	1	Guide-Belt	30	144-4738	4	Nut-Hex
11	144-4995	1	Arm-Forward	31	144-4958	1	Washer-Flat
12	144-4996	1	Screw-HH	32	144-5014	1	Frame-Red
13	144-4917	1	Belt Catch	33	144-5016	1	Tail Mount-Upper
14	144-4997	1	Belt	34	144-5017	4	Washer-Wheel
15	144-4688	1	Washer-Plain	35	144-5018	1	Key-Square
16	144-4999	1	Stake-Drag	36	144-5019	2	Spacer-Arm
17	144-5001	1	Shaft-Wheel	37	144-4835	4	Washer-Plain
18	144-5002	1	Shaft-Pivot	38	144-4964	1	Nut-Hex
19	144-5003	1	Handlebar-Front	39	144-4836	11	Nut-Hex
20	144-4794	2	Screw-Set				

# Tines and Transmission Assembly

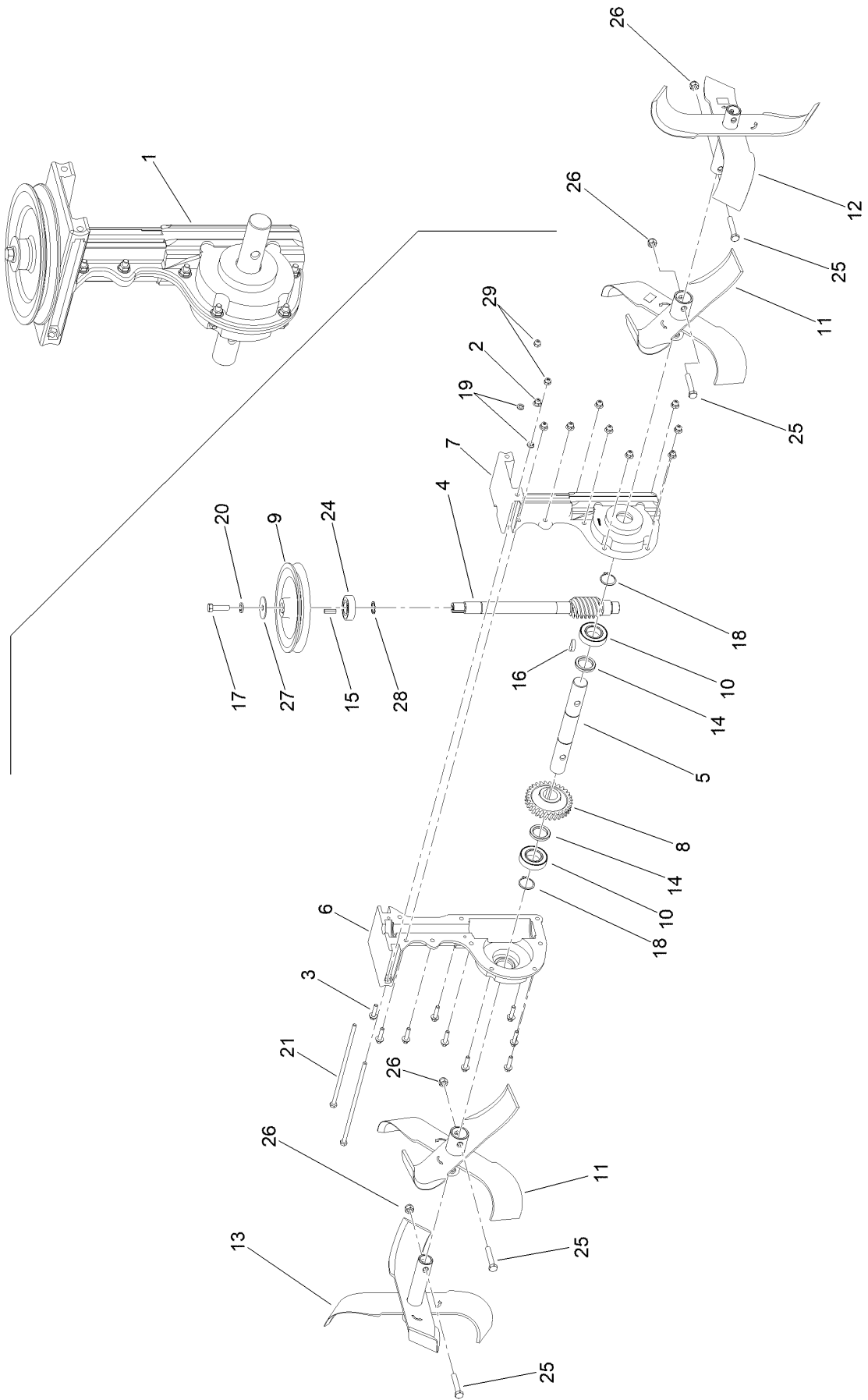

## Tines and Transmission Assembly (continued)

<i>Ref.</i>	<i>Part Number</i>	<i>Qty.</i>	<i>Description</i>	<i>Ref.</i>	<i>Part Number</i>	<i>Qty.</i>	<i>Description</i>
1	147-4295	1	Transmission ASM	15	144-4982	1	Key-Square
2	144-4879	9	Nut-Hex	16	144-4983	1	Key-Halfmoon
3	144-4967	9	Screw-RHF	17	144-4984	1	Screw-HHCS
4	144-4968	1	Driveshaft-Worm	18	144-4985	2	Snap Ring
5	144-4969	1	Driveshaft-Tine	19	144-4986	2	Washer-Lock
6	144-4970	1	Casting-Right	20	144-4987	1	Washer-Lock
7	144-4971	1	Casting-Left	21	144-4993	2	Screw-HHCS
8	144-4972	1	Gear-Transmission	24	144-4942	1	Bearing-Roller
9	144-4973	1	Pulley-Transmission	25	144-5000	4	Screw-HHCS
10	144-4974	2	Bearing-Output	26	144-4738	4	Nut-Hex
11	144-4975	2	Tine-Inner	27	144-5020	1	Washer-Flat
12	144-4882	1	Tine-Outside Left	28	144-5021	1	Ring-Retaining
13	144-4883	1	Tine-Outside Right	29	144-4836	2	Nut-Hex
14	144-4979	2	Spacer-Output				

# Handles and Controls Assembly

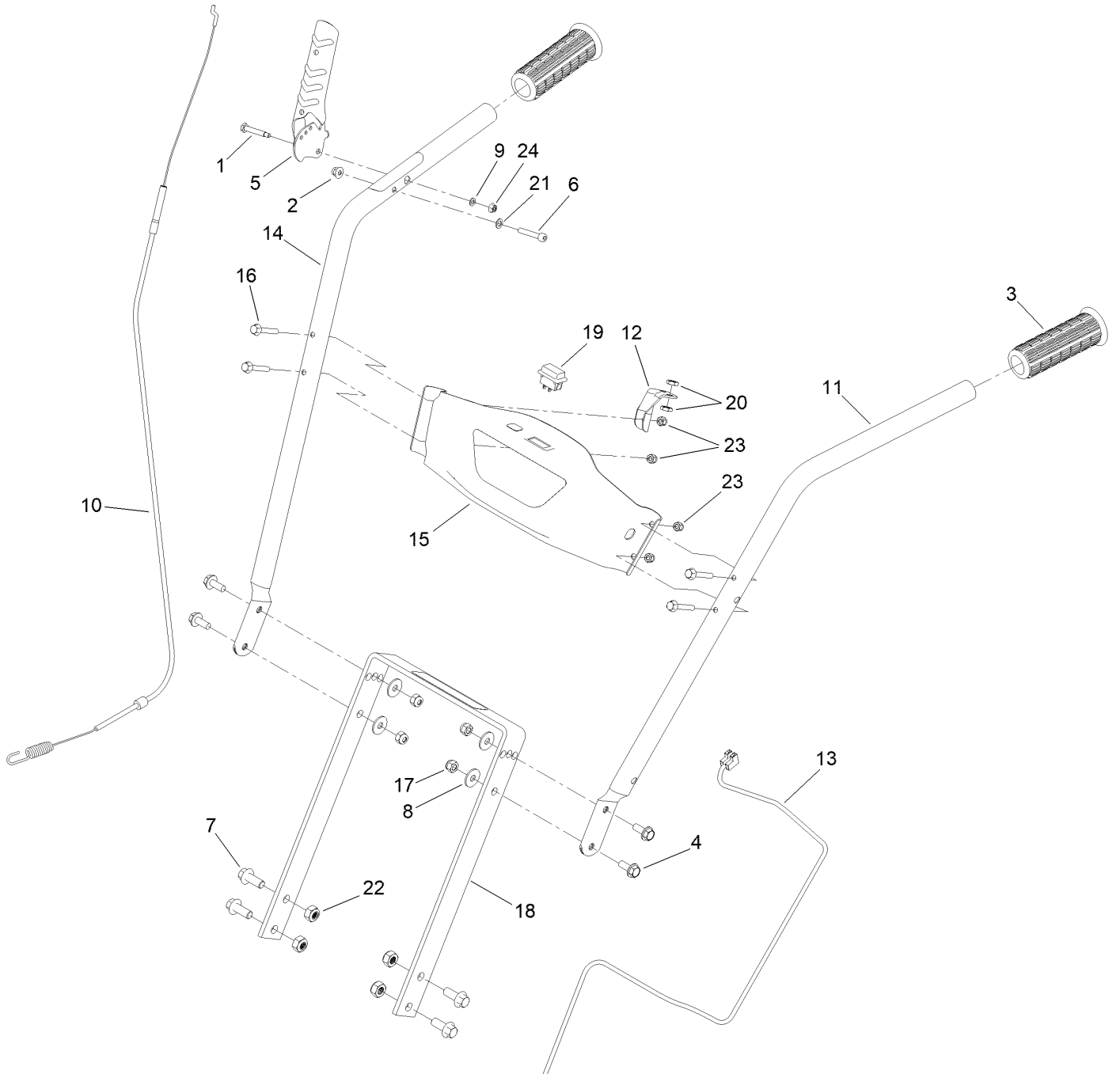



## Handles and Controls Assembly (continued)

<i>Ref.</i>	<i>Part Number</i>	<i>Qty.</i>	<i>Description</i>	<i>Ref.</i>	<i>Part Number</i>	<i>Qty.</i>	<i>Description</i>
1	144-4877	1	Screw-HH	13	144-4948	1	Bracket-Cable
2	144-4879	1	Nut-Hex	14	144-5012	1	Harness-Wiring
3	144-4881	2	Grip	15	144-4952	1	Handlebar-Right
4	144-4976	4	Screw-HSF	16	144-4953	1	Dash-Tiller
5	144-4980	1	Lever-Clutch	17	144-4956	4	Screw-HHF
6	144-4906	1	Screw-SHCS	18	144-4738	4	Nut-Hex
7	144-4991	4	Screw-Rhsf	19	144-5015	1	Mount-Handlebar
8	144-4936	4	Washer-Flat	20	144-4960	1	Switch
9	144-4938	1	Nut-Hex	21	144-4755	2	Nut
10	144-4941	1	Washer-Flat	22	144-4777	1	Washer
11	144-5004	1	Drive-Cable	23	144-4964	4	Nut-Hex
12	144-4947	1	Handlebar-Left	24	144-4836	4	Nut-Hex

**Notes:**

**Notes:**



**Count on it.**