



Count on it.

Parts Catalog

Field Pro 6040

Model No. 08839—Serial No. 415000000 and Up



Ordering Replacement Parts

To order replacement parts, please supply the part number, the quantity, and the description of each part desired.

Understanding Reference Numbers

Each identified part in an illustration has a reference number. The reference number for a part also appears in the parts list, along with other information about the part.

This catalog uses two special reference number formats, one to indicate parts in a service assembly and another to indicate the quantity of a given part in an illustration.

Service Assembly Reference Numbers

Parts in service assemblies have reference numbers in the form a:b. The a represents the reference number of the entire service assembly and the b represents a sequential number unique to each part within the service assembly.

For example, a wheel assembly might be identified by reference number 6, the tire by 6:1, the valve by 6:2, and the wheel by 6:3. When you order the assembly identified by reference number 6, you receive all parts identified by reference numbers 6:1, 6:2, and 6:3. However, you may also order any part individually. Reference numbers of this type appear in illustration and in parts lists.

Reference Numbers Indicating Quantity

In an illustration, if a reference number indicates more than one part, the reference number has the form nX y. The n represents the quantity of the part, the X is the multiplication symbol, and the y represents the reference number.

For example, in an illustration, the reference number 2X 37 means that two of the parts identified by reference number 37 are indicated.

Contents

Front Frame Assembly	4
Caster Wheel Assembly	6
Caster Wheel Assembly No. 133-4723.....	8
Main Frame Assembly.....	10
Wheel Assembly No. 144-7528.....	12
Control Panel Assembly	14
Control Panel Assembly No. 147-3703SP	16
Top Cover Assembly	18
Speed Control and Parking Brake Assembly.....	20
LH Control Handle Assembly No. 144-4601	22
LH Control Rod Assembly No. 144-4582	24
RH Control Rod Assembly No. 144-4581.....	26
Brake Bellcrank W/Bushing Assembly No. 144-4587.....	28
Hydraulic Tank Assembly	30
Hydraulic Tank Assembly No. 145-7444SP	32
Hydraulic Drive Assembly.....	34
5 Stud Wheel Hub Kit Assembly No. 135-5333.....	36
Hydraulic Gear Pump Assembly No. 144-7596.....	38
Hydraulic Control Assembly	40
Oil Cooler Assembly	42
Hydraulic Lift Circuit Plumbing Assembly.....	44
Hydraulic Cylinder Assembly No. 145-4233	46
Hydraulic Lift Cylinder Assembly No. 115-5647	48
Electrical Assembly	50
Wire Harness Assembly No. 122-2657.....	52
Engine, Belt and Muffler Assembly	54
Tensioner Assembly.....	56
Fuel Tank Assembly.....	58
Fuel Tank Assembly No. 145-7445SP	60
Engine Air Cleaner and Fuel System Assembly	62
Air Cleaner Assembly No. 117-9989.....	64
Rear Frame Assembly.....	66
Rear Attachment Mount Assembly	68
Attachments and Accessories	70

Front Frame Assembly

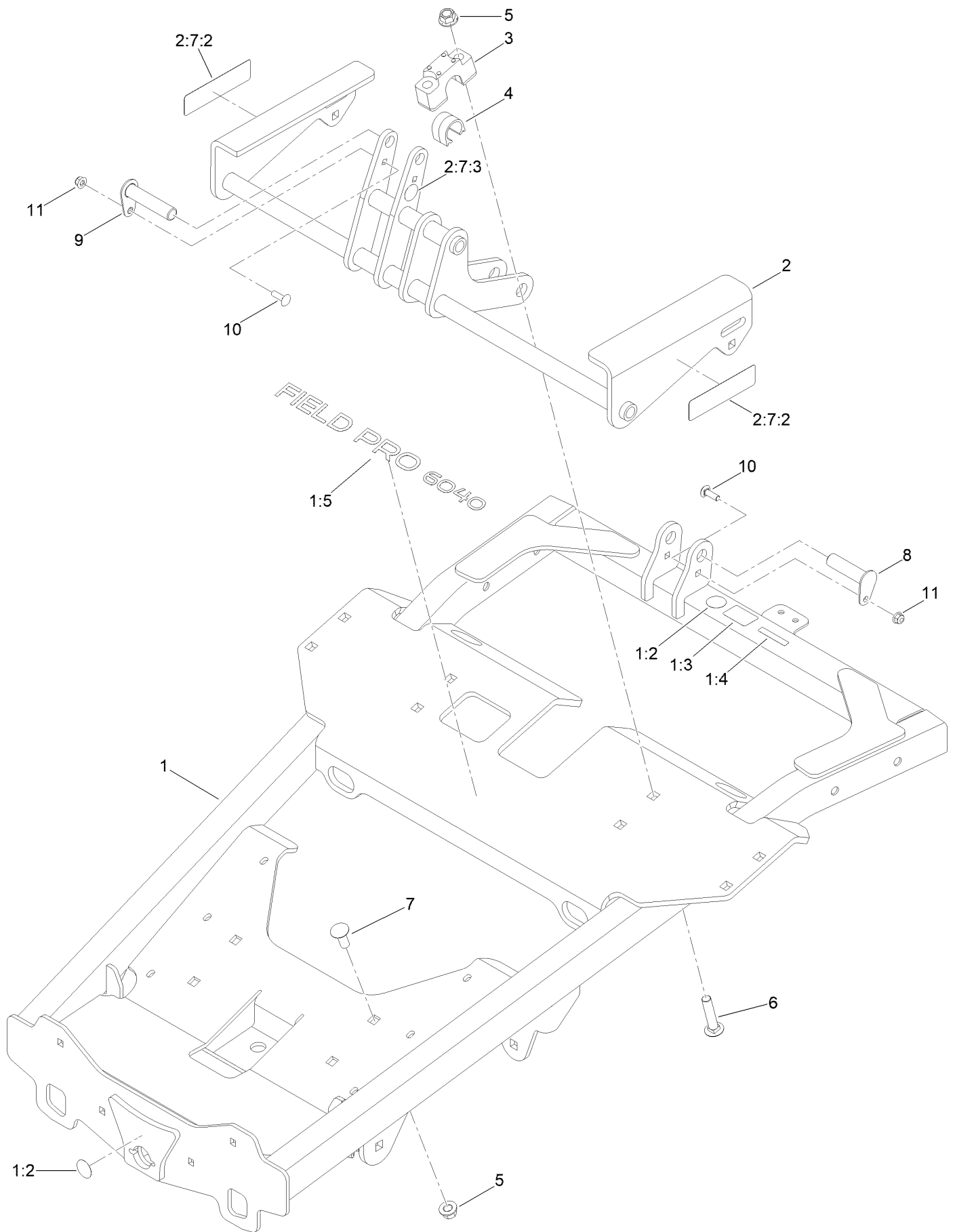

Front Frame Assembly (continued)

<i>Ref.</i>	<i>Part Number</i>	<i>Qty.</i>	<i>Description</i>	<i>Ref.</i>	<i>Part Number</i>	<i>Qty.</i>	<i>Description</i>
1	147-3710	1	Front Frame ASM W/Decals	4	109-9410	4	Bearing-Cross Shaft, Front
1:2	58-6520	2	Decal-Grease	5	99-5107	12	Nut-Lock
1:3	106-5517	1	Decal-Warning	6	116-1700	8	Bolt-CARR
1:4	120-9570	1	Decal-Warning	7	3233-26	4	Screw-CARR,Shortneck
1:5	145-7410	1	Decal - Fieldpro 6040	8	140-6323	1	Pin
2	145-7446SP	1	Lift Arm ASM W/Decals	9	147-3617	1	Pin-Mounting
2:7:2	145-1774	2	Decal-Stored Energy Attachment	10	3230-22	2	Screw-CARR
2:7:3	58-6520	1	Decal-Grease	11	104-8300	2	Nut-HF, NI
3	109-9409	4	Support-Bearing, Cross Shaft (Front)				

Caster Wheel Assembly

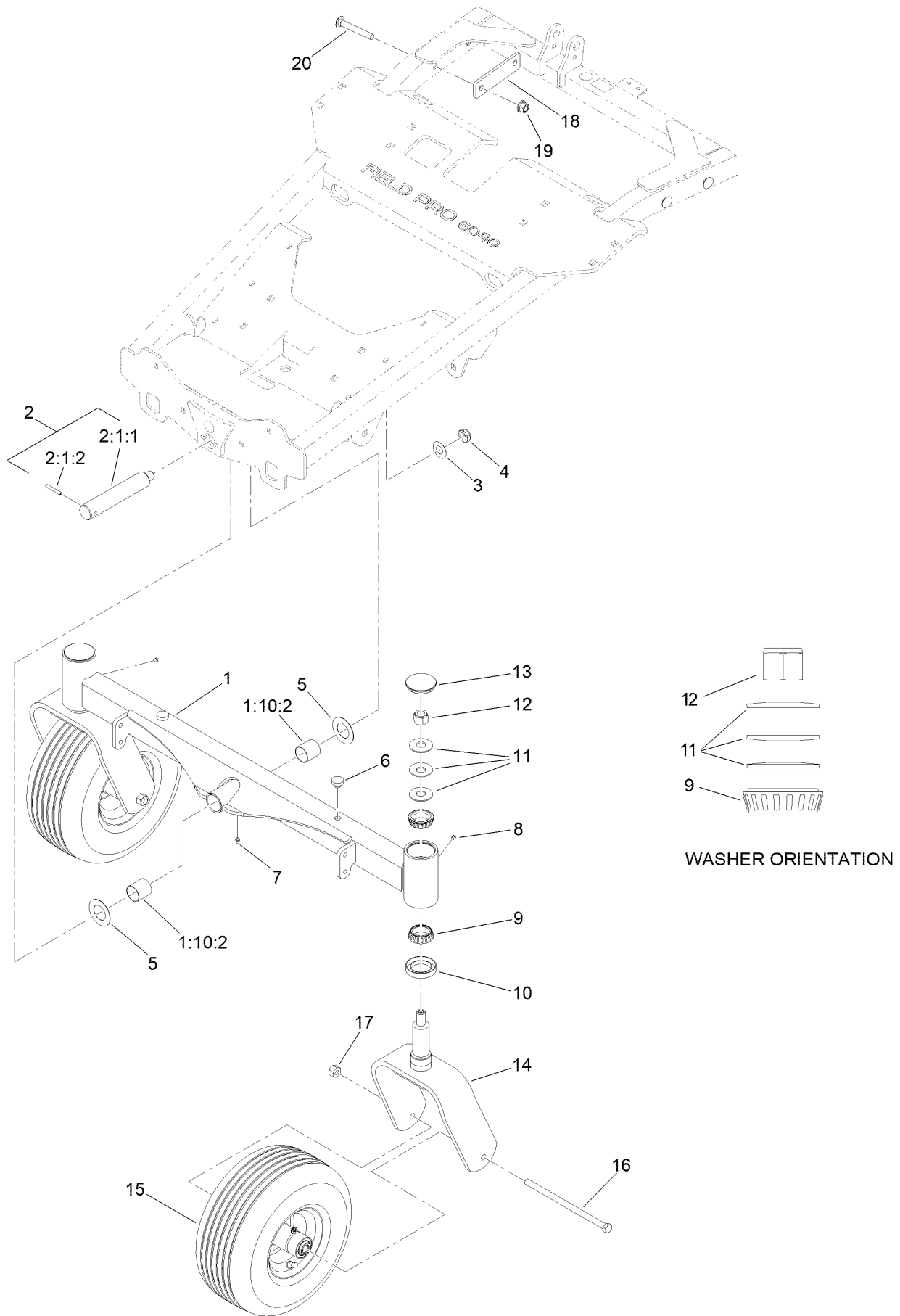

Caster Wheel Assembly (continued)

<i>Ref.</i>	<i>Part Number</i>	<i>Qty.</i>	<i>Description</i>	<i>Ref.</i>	<i>Part Number</i>	<i>Qty.</i>	<i>Description</i>
1	145-1816SP	1	Axle ASM W/Bushings	10	69-2980	2	Seal
1:10:2	99-6964	2	Bushing-Axle	11	108-9957	6	Washer-Belleville
2	145-1838-03	1	Axle Pivot Pin ASM	12	3296-51	2	Nut-Lock, NI
2:1:1	145-1839	1	Pin-Axle Pivot	13	108-9950	2	Cap-Grease
2:1:2	32121-32	1	Pin-Roll	14	145-1830-01	2	Fork-Castor
3	71-4540	1	Washer-Thrust	15	133-4723	2	Caster Wheel ASM
4	3296-15	1	Nut-Lock, NI	16	325-39	2	Screw-HH
5	99-8432	2	Washer-Thrust	17	3296-25	2	Nut-Lock, NI
6	140-3460	2	Bumper-Rubber	18	144-7519	2	Plate-Clamp
7	302-5	1	Fitting-Grease	19	99-5107	4	Nut-Lock
8	1-811010	2	Plug	20	3233-10	4	Screw-CARR
9	254-106	4	Cone-Bearing, Tapered				

Caster Wheel Assembly No. 133-4723

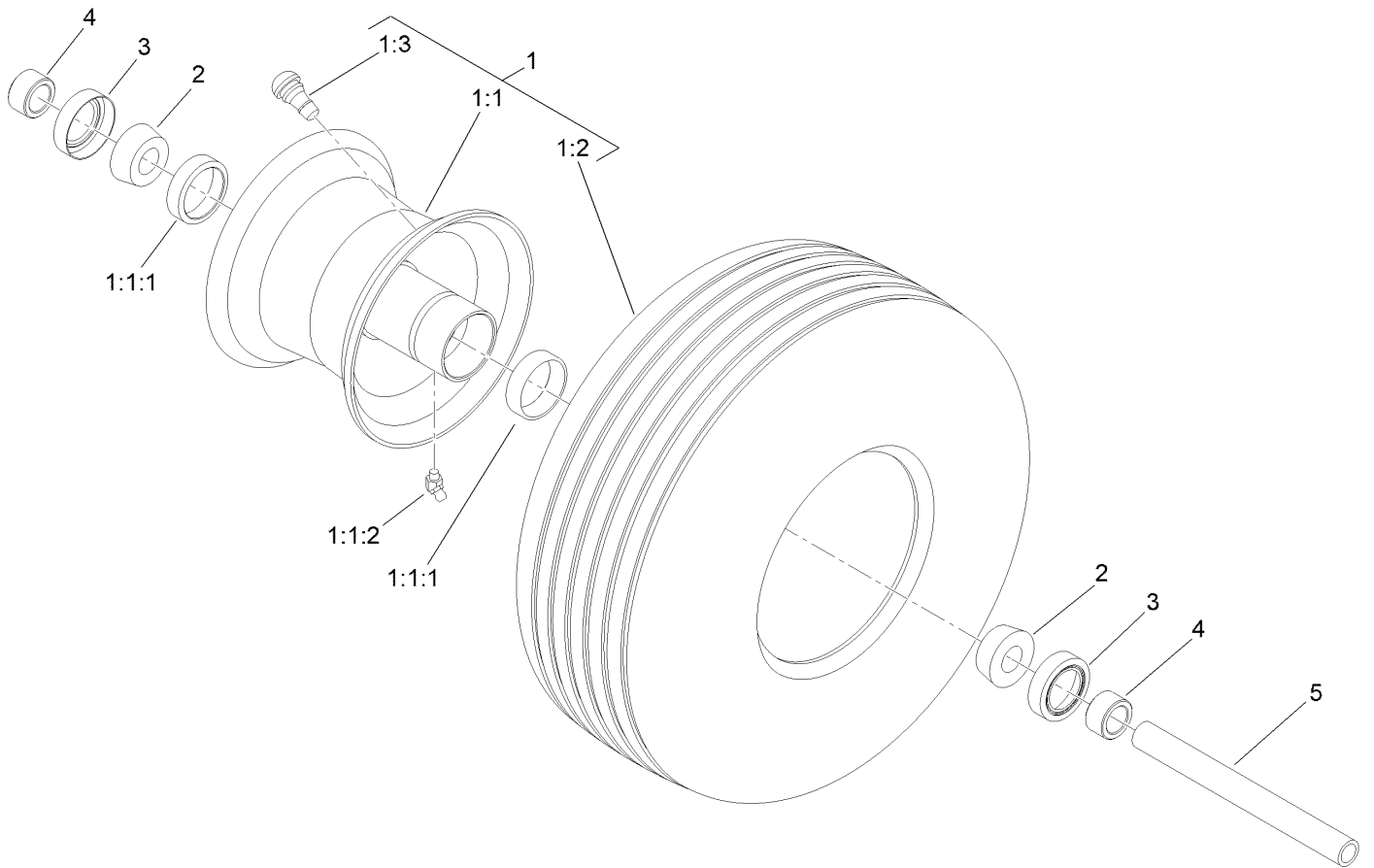

Caster Wheel Assembly No. 133-4723 (continued)

<i>Ref.</i>	<i>Part Number</i>	<i>Qty.</i>	<i>Description</i>
1	133-4730	1	Tire And Wheel ASM
1:1	133-4725	1	Wheel
1:1:1	1-633584	2	Bearing-Cup
1:1:2	302-11	1	Fitting-Lube, 45 DEG
1:2	133-4724	1	Tire

<i>Ref.</i>	<i>Part Number</i>	<i>Qty.</i>	<i>Description</i>
1:3	5108	1	Valve
2	1-633585	2	Bearing-Cone, Taper
3	1-633580	2	Seal-Bearing
4	1-633581	2	Spacer-Bearing
5	138-1933	1	Spacer, Front Caster

Main Frame Assembly

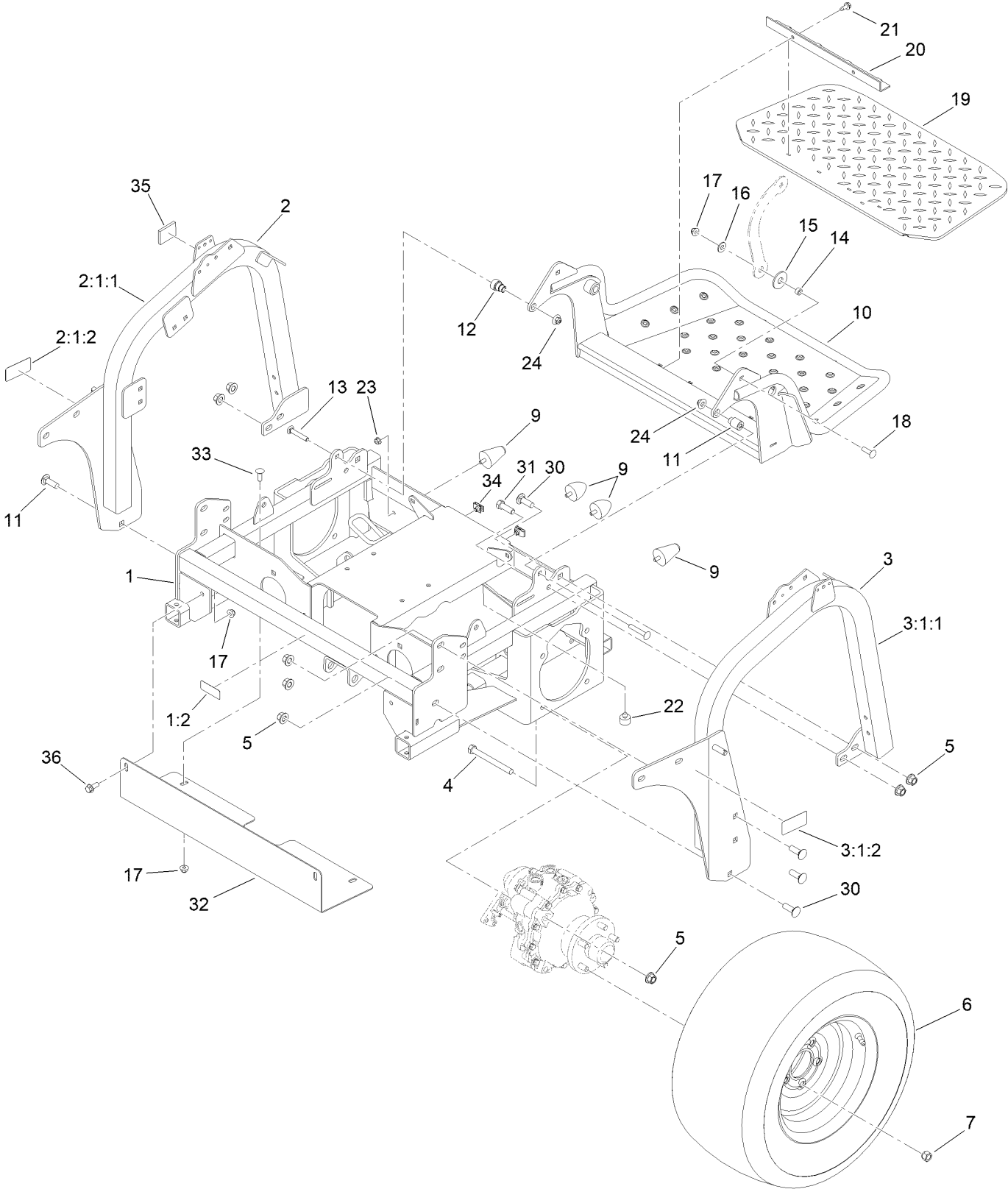

Main Frame Assembly (continued)

<i>Ref.</i>	<i>Part Number</i>	<i>Qty.</i>	<i>Description</i>	<i>Ref.</i>	<i>Part Number</i>	<i>Qty.</i>	<i>Description</i>
1	147-3709	1	Main Frame ASM W/Decal	15	114-0463	2	Washer-Friction, Composite
1:2	132-1316	1	Decal-Danger, Belt	16	3256-4	2	Washer-Flat
2	145-7448SP	1	RH Frame ASM W/Decals	17	104-8301	6	Nut-HF, NI
2:1:1		1	Frame-RH ●	18	3231-28	2	Screw-CARR
2:1:2	138-4107	1	Decal-Hazard, Pinch	19	126-7157	1	Mat-Platform
3	145-7449SP	1	LH Frame ASM W/Decals	20	114-1920-03	1	Clamp-Shield
3:1:1		1	Frame-LH ●	21	32144-70	2	Screw-HWHTF
3:1:2	138-4107	1	Decal-Hazard, Pinch	22	120-7893	1	Bumper-Grommet
4	325-19	8	Screw-HH	23	104-8300	4	Nut-HF, NI
5	99-5107	18	Nut-Lock	24	109-6658	2	Nut-Flange, NI
6	144-7528	2	Wheel ASM	30	3233-2	8	Screw-CARR
7	242-50	10	Nut-Lug	31	325-6	2	Screw-HH
9	114-1926	4	Bumper-Rubber	32	145-7408SP	1	Bracket-Shield, Belt
10	120-8475-03SP	1	Platform ASM	33	3231-22	2	Screw-CARR
11	144-7613	1	Bushing-Flanged	34	115-7721	2	Nut-Clip, U
12	147-3306	1	Bushing-Flanged	35	147-3336	1	Seal-Foam
13	3231-40	2	Bolt-CARR	36	3234-42	2	Screw-HHF
14	111044	2	Spacer				

● Not serviced separately

Wheel Assembly No. 144-7528

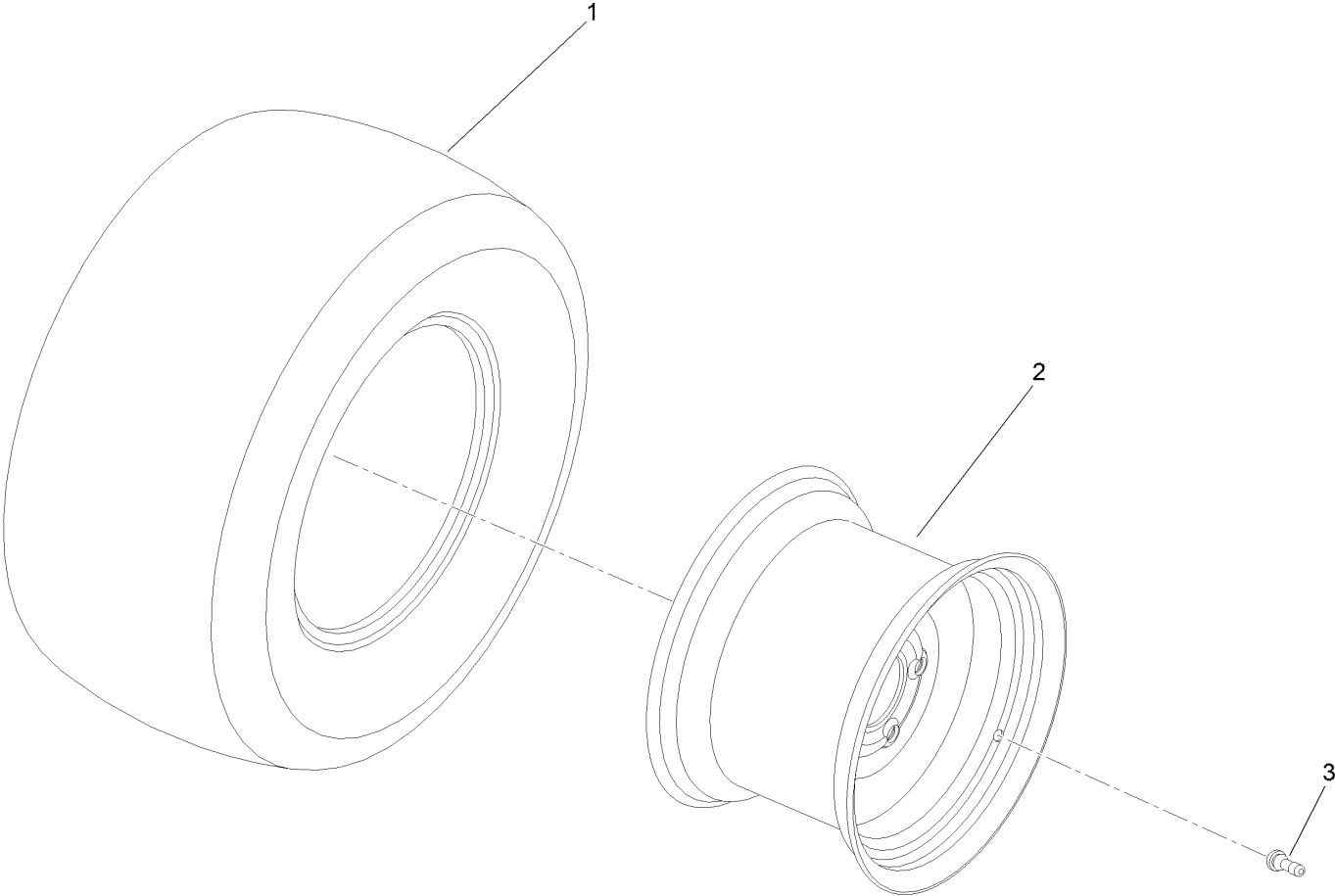

Wheel Assembly No. 144-7528 (continued)

<i>Ref.</i>	<i>Part Number</i>	<i>Qty.</i>	<i>Description</i>
1	137-2594	1	Tire
2	144-7527	1	Rim
3	232-27	1	Stem-Valve

Control Panel Assembly

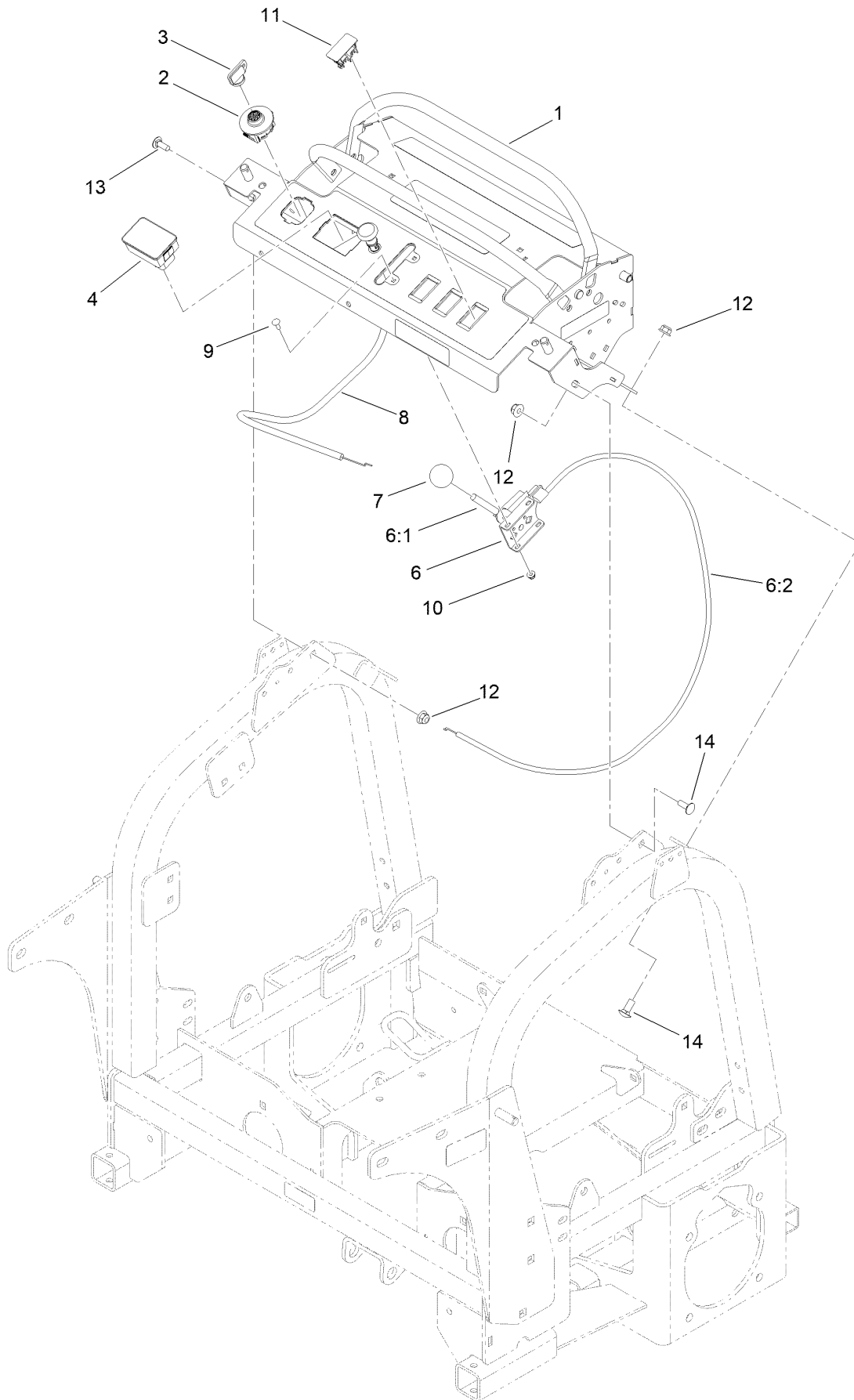

Control Panel Assembly (continued)

<i>Ref.</i>	<i>Part Number</i>	<i>Qty.</i>	<i>Description</i>	<i>Ref.</i>	<i>Part Number</i>	<i>Qty.</i>	<i>Description</i>
1	147-3703SP	1	Control Panel ASM W/Decals	7	233-42	1	Knob
2	137-4101	1	Switch-Ignition	8	132-9035	1	Cable-Choke
3	63-8360	1	Key-Ignition	9	1-807533	2	Bolt-CARR
4	116-5609	1	Module ASM	10	120-4578	2	Nut-HF
6	115-2755	1	Control-Throttle ASM	11	119-7791	3	Plug-Hole
6:1	112-2334	1	Lever-Throttle	12	104-8301	4	Nut-HF, NI
6:2	115-3867	1	Cable-Throttle	13	3230-10	2	Bolt-CARR
				14	3231-27	2	Screw-CARR

Control Panel Assembly No. 147-3703SP

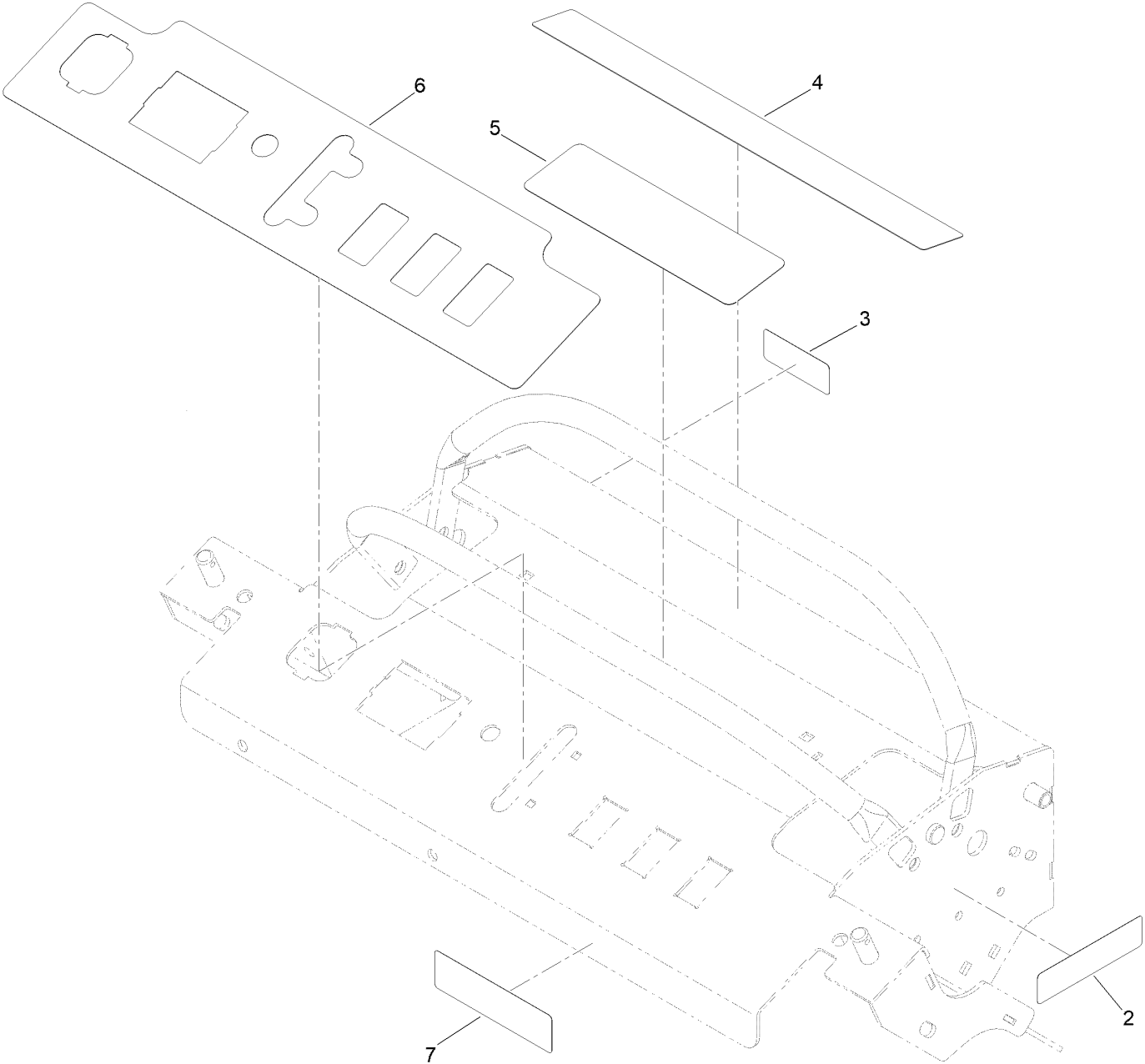

Control Panel Assembly No. 147-3703SP (continued)

<i>Ref.</i>	<i>Part Number</i>	<i>Qty.</i>	<i>Description</i>	<i>Ref.</i>	<i>Part Number</i>	<i>Qty.</i>	<i>Description</i>
2	133-8062	1	Decal-Spark Arrestor	5	145-1765	1	Decal-Controls
3	145-1775	1	Decal-Fuse	6	145-1764	1	Decal-Panel, Control
4	145-1772	1	Decal-Warning	7	115-4855	1	Decal-Caution

Top Cover Assembly

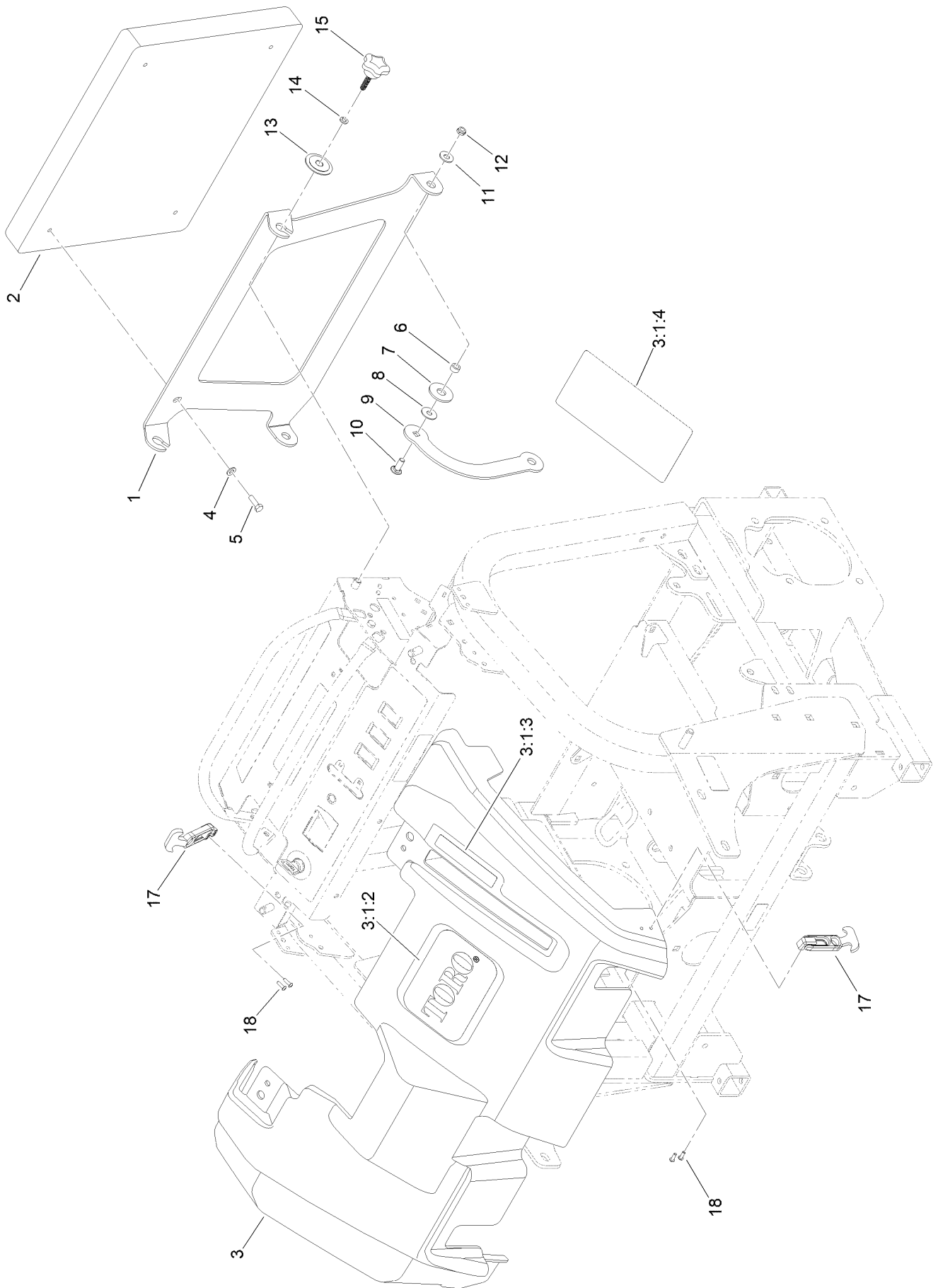

Top Cover Assembly (continued)

<i>Ref.</i>	<i>Part Number</i>	<i>Qty.</i>	<i>Description</i>	<i>Ref.</i>	<i>Part Number</i>	<i>Qty.</i>	<i>Description</i>
1	120-8499-03	1	Hinge-Pad	8	119-4150	2	Washer-Flat
2	117-9739	1	Pad-Cushion	9	144-4470-03	2	Link-Platform
3	145-7443SP	1	Cover Top ASM W/Decals	10	3231-22	2	Screw-CARR
3:1:2	67-7320	1	Decal	11	3256-4	2	Washer-Flat
3:1:3	139-6224	1	Decal-Brake, Parking	12	3296-59	2	Nut-Lock, NI
3:1:4	147-6696	1	Decal-Service	13	116-2886	2	Slide-Bushing
4	3256-23	4	Washer-Plain	14	3253-4	2	Washer-Lock
5	121-7999	4	Screw-HH	15	139-2401	2	Knob
6	111044	2	Spacer	17	103-4080	4	Latch-Rubber
7	114-0463	2	Washer-Friction, Composite	18	3274-39	8	Screw-HSBH

Speed Control and Parking Brake Assembly

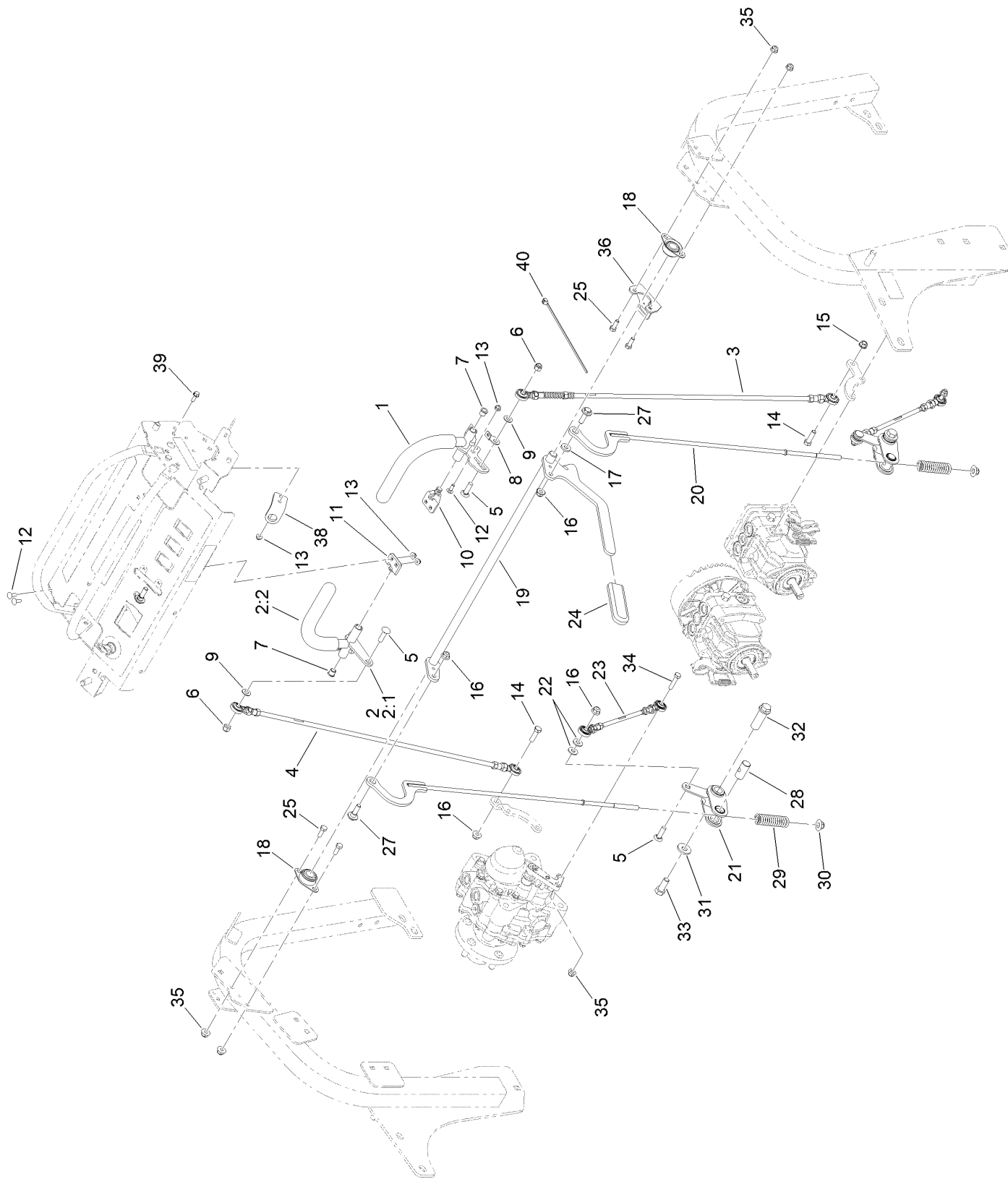

Speed Control and Parking Brake Assembly (continued)

<i>Ref.</i>	<i>Part Number</i>	<i>Qty.</i>	<i>Description</i>	<i>Ref.</i>	<i>Part Number</i>	<i>Qty.</i>	<i>Description</i>
1	144-4601	1	LH Control Handle ASM	19	144-4594-03	1	Shaft-Brake, Parking
2	144-4598	1	RH Control Handle ASM	20	144-4590	2	Link
2:1	144-4597-03	1	Control-Motion, RH	21	144-4587	2	Bellcrank-Brake W/Bushing
2:2	119-0222	1	Grip	22	3256-3	4	Washer-Flat
3	144-4582	1	LH Control Rod ASM	23	144-4536	2	Turnbuckle ASM
4	144-4581	1	RH Control Rod ASM	24	1-633268	1	Grip-Lever
5	3231-28	4	Screw-CARR	25	322-4	4	Screw-HH
6	3296-39	2	Nut-Lock, NI	27	614672	2	Screw-Shoulder, HWH
7	103-9928	2	Bearing	28	1-633144	2	Pin-Trunion
8	132-7538	1	Bracket-Adjustment, Speed	29	109-2230	2	Spring-Compression
9	132-4593	2	Washer	30	109-6658	2	Nut-Flange, NI
10	120-3288	1	Tab-Pivot, LH	31	1-513435	2	Washer-Spring
11	120-3287	1	Tab-Pivot, RH	32	109-5891	2	Hub-Threaded
12	3229-1	4	Screw-CARR	33	325-5	2	Screw-HH
13	104-7201	8	Nut-HF, NI	34	322-7	2	Screw-HH
14	323-7	2	Screw-HH	35	104-8300	6	Nut-HF, NI
15	3290-357	1	Nut-HSF	36	144-7542-03	1	Bracket-Switch, Brake
16	104-8301	5	Nut-HF, NI	38	144-7543-03	2	Bracket-Switch
17	71-9310	1	Spacer	39	115-5103	4	Screw-HHF
18	1-633102	2	Bearing-Flange, Side	40	1-303287	2	Tie-Cable

LH Control Handle Assembly No. 144-4601

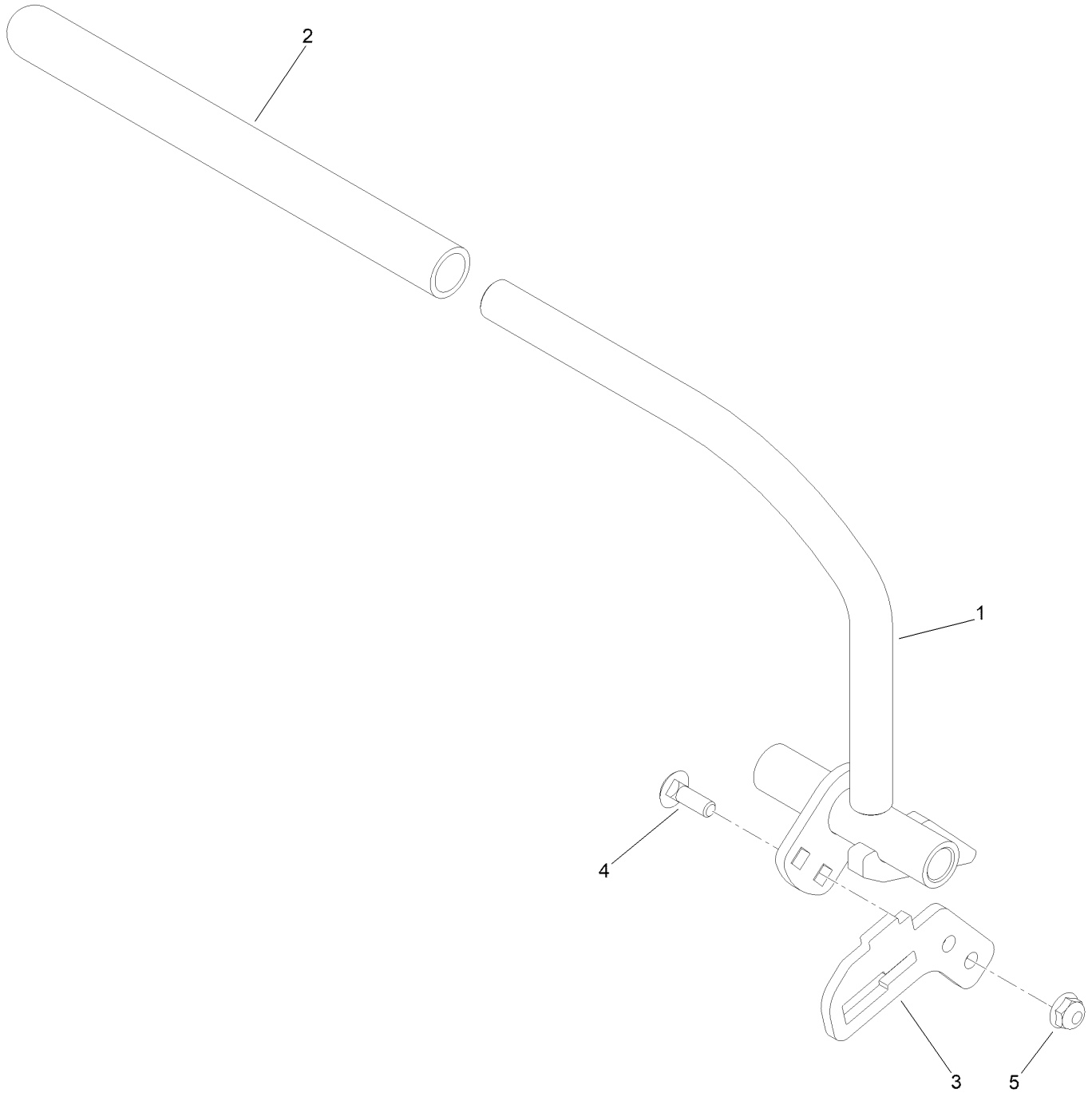

LH Control Handle Assembly No. 144-4601 (continued)

<i>Ref.</i>	<i>Part Number</i>	<i>Qty.</i>	<i>Description</i>	<i>Ref.</i>	<i>Part Number</i>	<i>Qty.</i>	<i>Description</i>
1	144-4600-03	1	Control-Motion, LH	4	3229-1	2	Screw-CARR
2	119-0222	1	Grip	5	104-7201	2	Nut-HF, NI
3	144-4599	1	Plate-Rod, Control				

LH Control Rod Assembly No. 144-4582

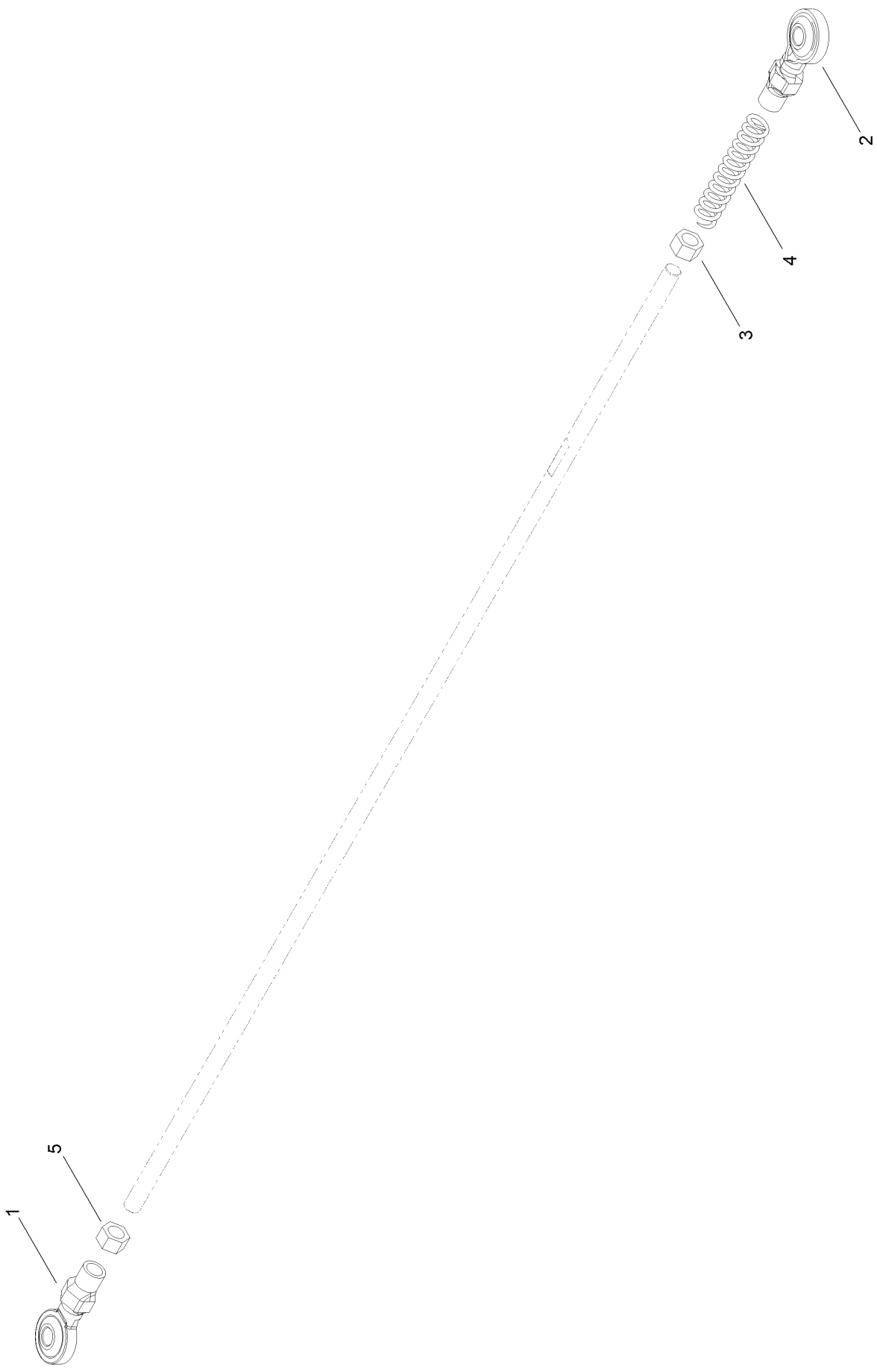

LH Control Rod Assembly No. 144-4582 (continued)

<i>Ref.</i>	<i>Part Number</i>	<i>Qty.</i>	<i>Description</i>	<i>Ref.</i>	<i>Part Number</i>	<i>Qty.</i>	<i>Description</i>
1	138-4647	1	Ball Joint-LH	4	1-603807	1	Spring-Return, Neutral
2	138-4648	1	Ball Joint-RH	5	3219-20	1	Nut-Hex, LH
3	3219-3	1	Nut-Hex				

RH Control Rod Assembly No. 144-4581

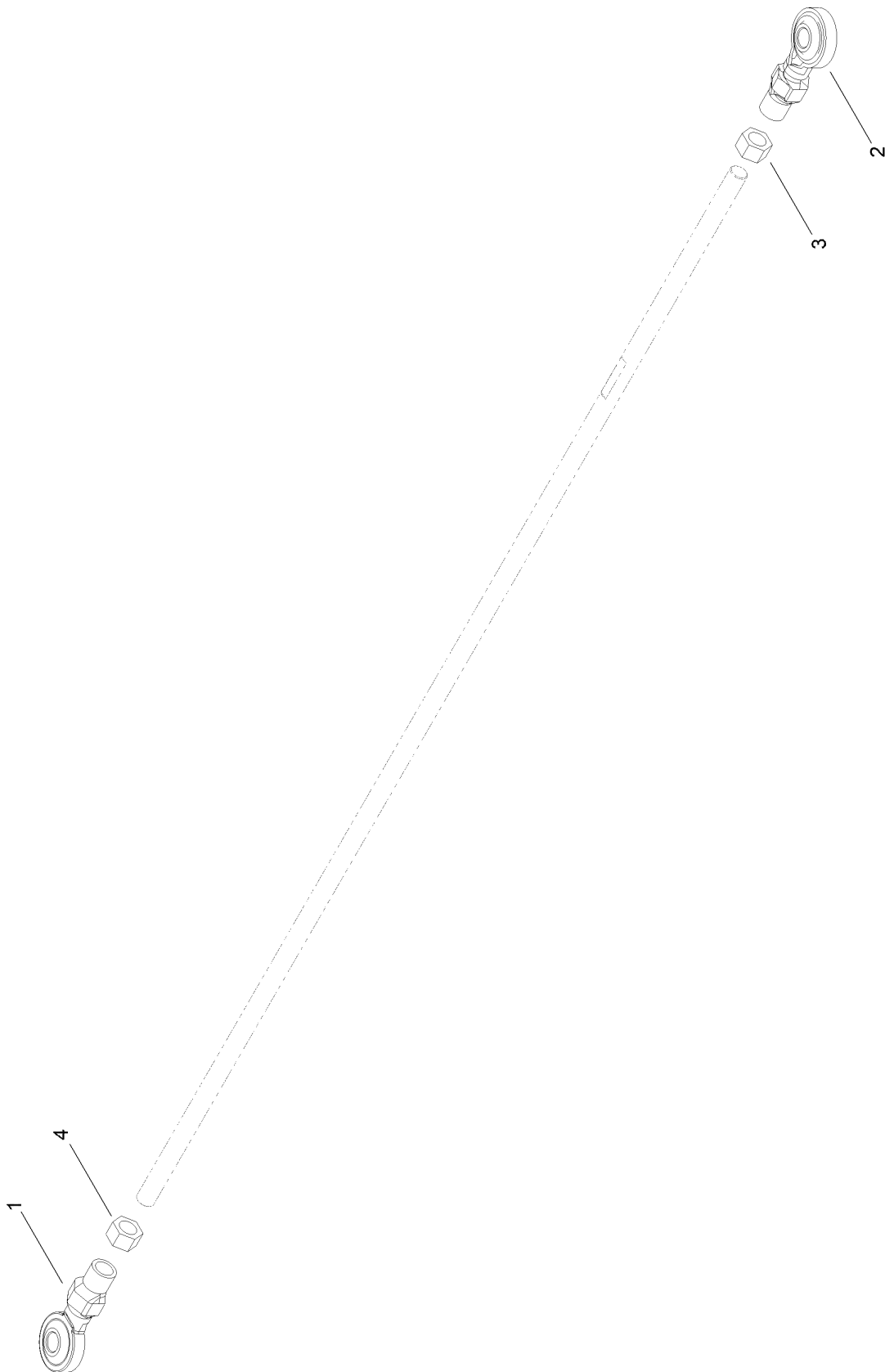

RH Control Rod Assembly No. 144-4581 (continued)

<i>Ref.</i>	<i>Part Number</i>	<i>Qty.</i>	<i>Description</i>	<i>Ref.</i>	<i>Part Number</i>	<i>Qty.</i>	<i>Description</i>
1	138-4647	1	Ball Joint-LH	3	3219-3	1	Nut-Hex
2	138-4648	1	Ball Joint-RH	4	3219-20	1	Nut-Hex, LH

Brake Bellcrank W/Bushing Assembly No. 144-4587

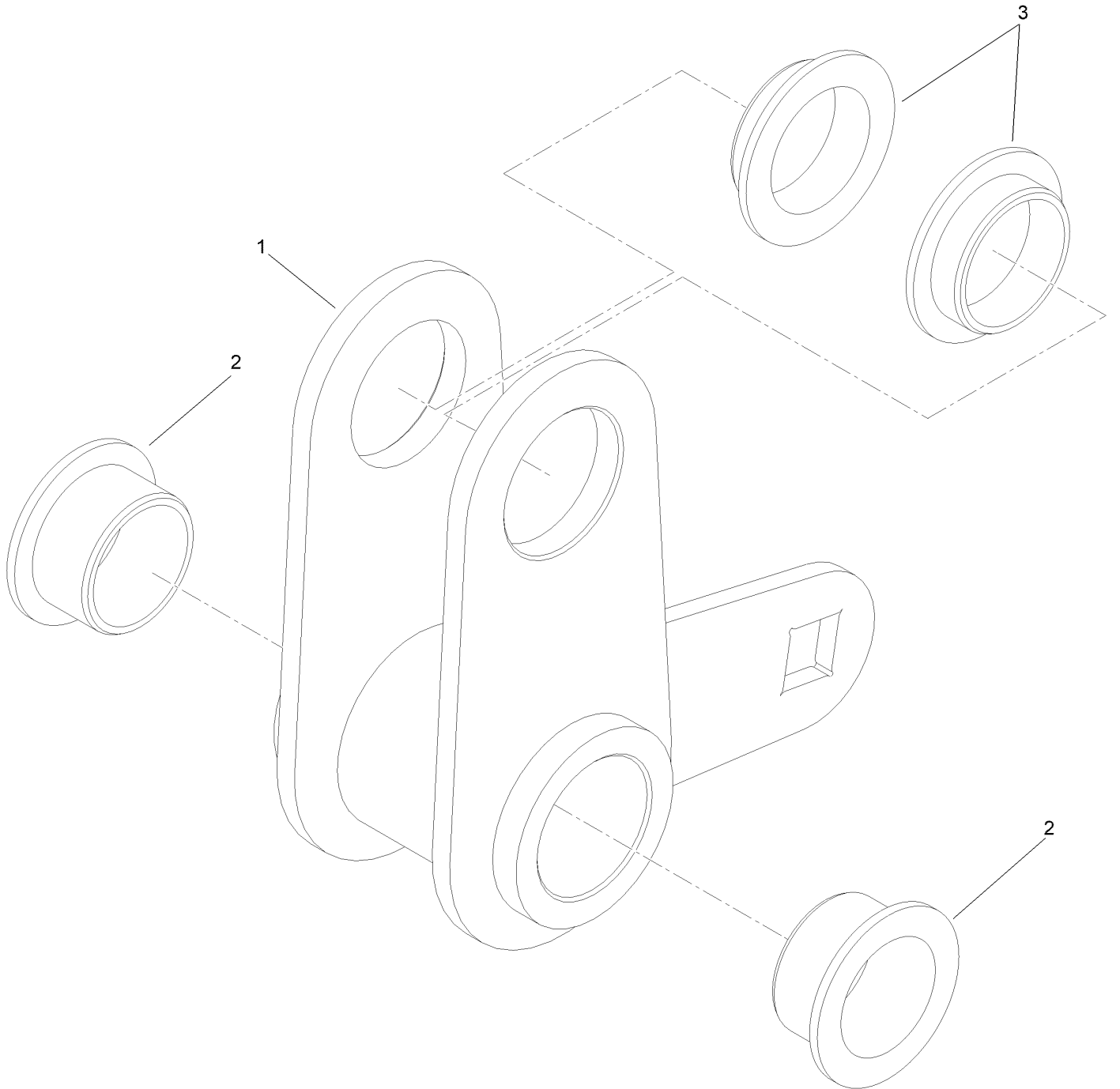

Brake Bellcrank W/Bushing Assembly No. 144-4587 (continued)

<i>Ref.</i>	<i>Part Number</i>	<i>Qty.</i>	<i>Description</i>
1	140-6332	1	Bellcrank-Brake
2	109-8054	2	Bushing-Flange
3	135-2840	2	Bushing-Flange

Hydraulic Tank Assembly

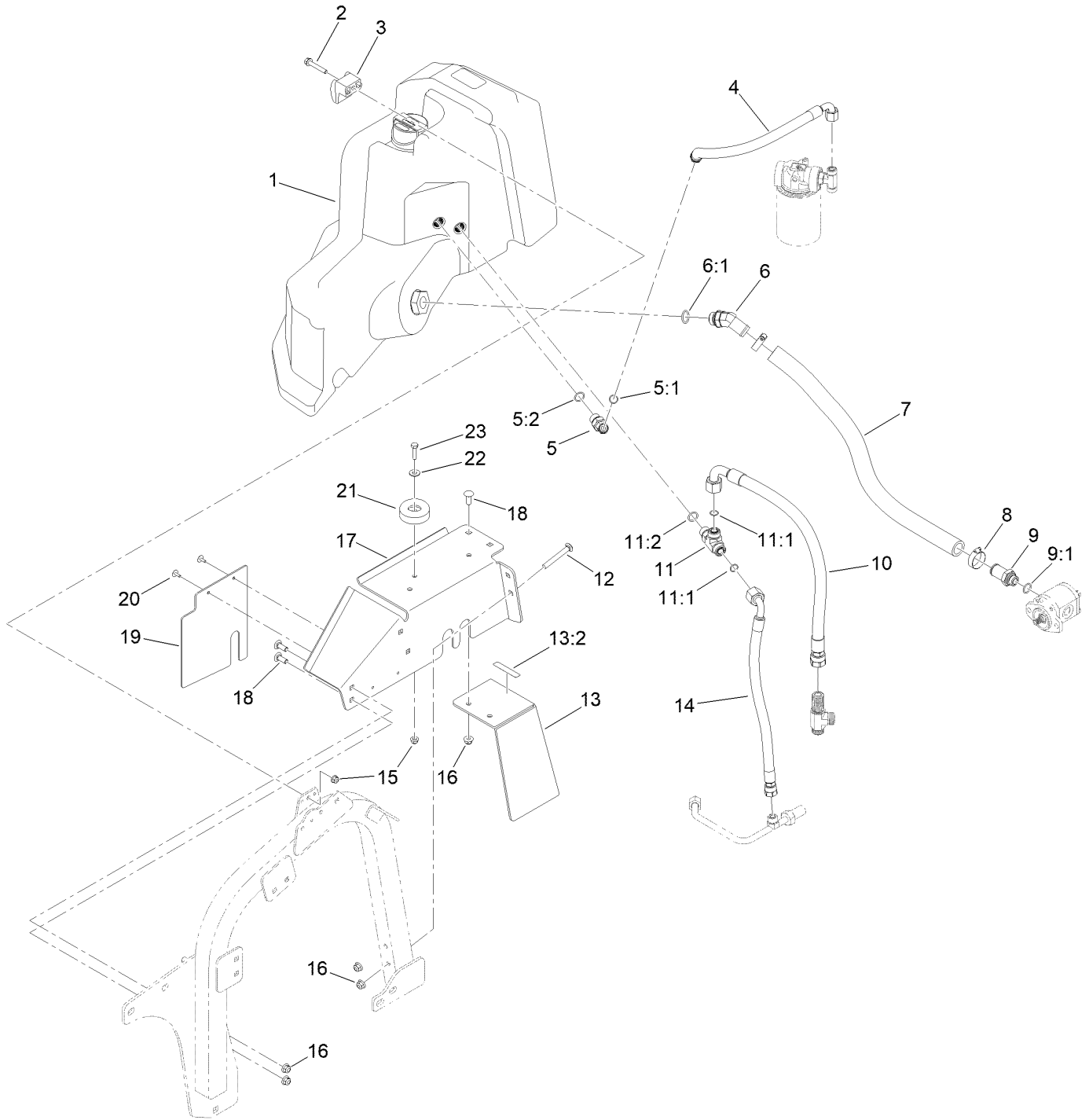

Hydraulic Tank Assembly (continued)

<i>Ref.</i>	<i>Part Number</i>	<i>Qty.</i>	<i>Description</i>	<i>Ref.</i>	<i>Part Number</i>	<i>Qty.</i>	<i>Description</i>
1	145-7444SP	1	Hydro Tank ASM	11:2	237-80	1	O-Ring
2	142-6275	1	Screw-HHF	12	3231-42	2	Screw-CARR
3	107-4543	1	Clamp	13	147-3714	1	RH Fender ASM W/Decal
4	147-3327	1	Hydraulic Hose ASM	13:2	135-0328	1	Decal-Torque, Wheel Nut
5	340-14	1	Fitting-HYD, 45 DEG	14	144-7290	1	Hydraulic Hose ASM
5:1	237-65	1	O-Ring	15	104-8300	2	Nut-HF, NI
5:2	237-80	1	O-Ring	16	104-8301	6	Nut-HF, NI
6	144-7172	1	Fitting-Elbow-45	17	144-7689-03	1	Bracket-Tank Mount, Hydraulic
6:1	237-81	1	O-Ring	18	3231-22	4	Screw-CARR
7	144-7287	1	Hose-Suction	19	147-3305	1	Flap-Cover, Side
8	2412-34	2	Clamp-Hose	20	3269-20	2	Rivet-Pop
9	131-0573	1	Fitting-STR	21	108-1605	1	Bumper-Recess
9:1	237-80	1	O-Ring	22	3256-3	1	Washer-Flat
10	144-7296	1	Hydraulic Hose ASM	23	322-6	1	Screw-HH
11	340-22	1	Fitting-Tee				
11:1	237-65	2	O-Ring				

Hydraulic Tank Assembly No. 145-7444SP

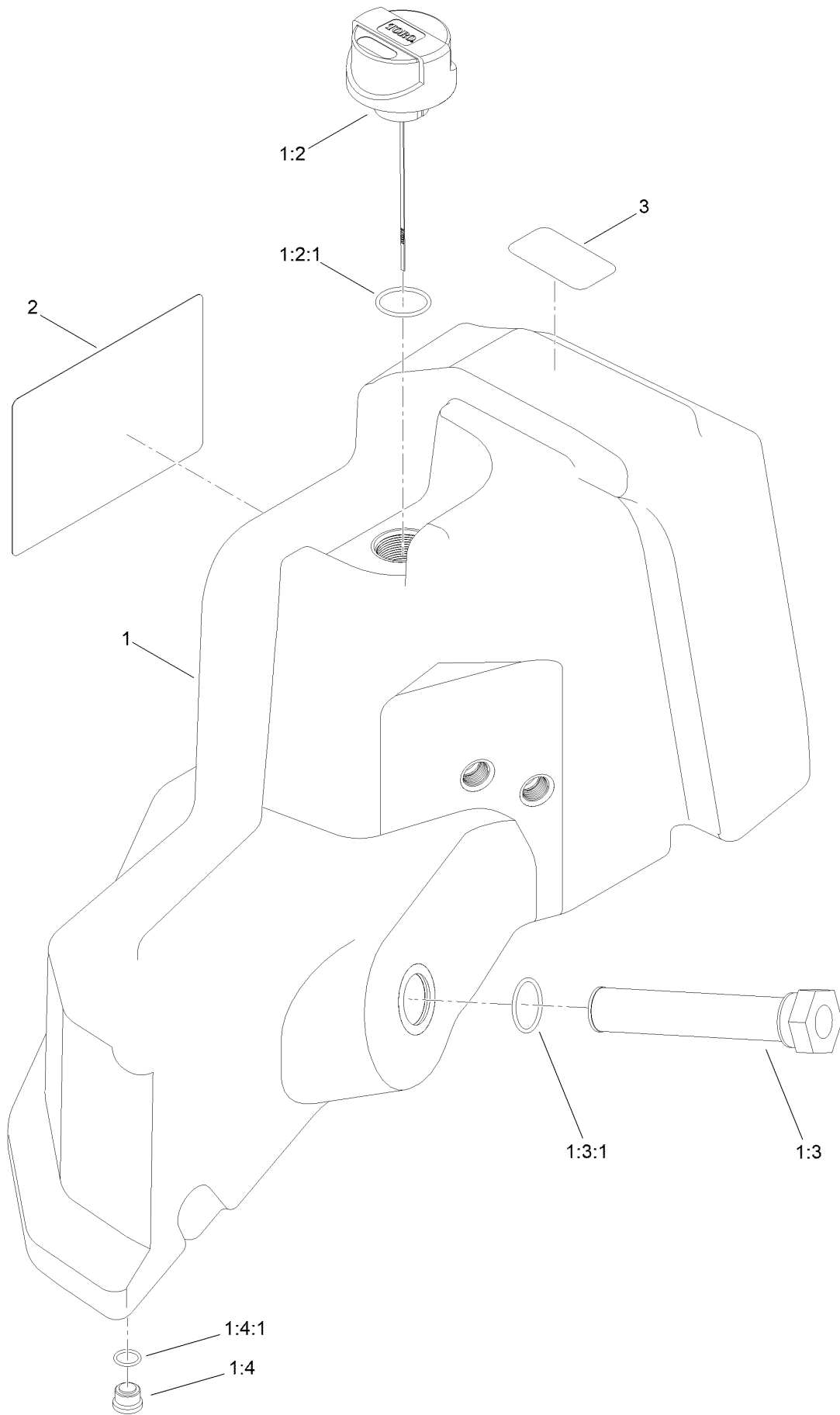

Hydraulic Tank Assembly No. 145-7444SP (continued)

<i>Ref.</i>	<i>Part Number</i>	<i>Qty.</i>	<i>Description</i>	<i>Ref.</i>	<i>Part Number</i>	<i>Qty.</i>	<i>Description</i>
1	145-7444	1	Hydro Tank ASM W/Decals	1:3:1	237-101	1	O-Ring
1:2	117-0193	1	Cap-Hydraulic, Vented Breather	1:4	133-7659	1	Plug ASM W/Magnet
1:2:1	237-101	1	O-Ring	1:4:1	237-79	1	O-Ring
1:3	87-3990	1	Strainer-Transaxle	2	145-1776	1	Decal-Field Pro 6040
				3	125-8483	1	Decal-HYD Fluid

Hydraulic Drive Assembly

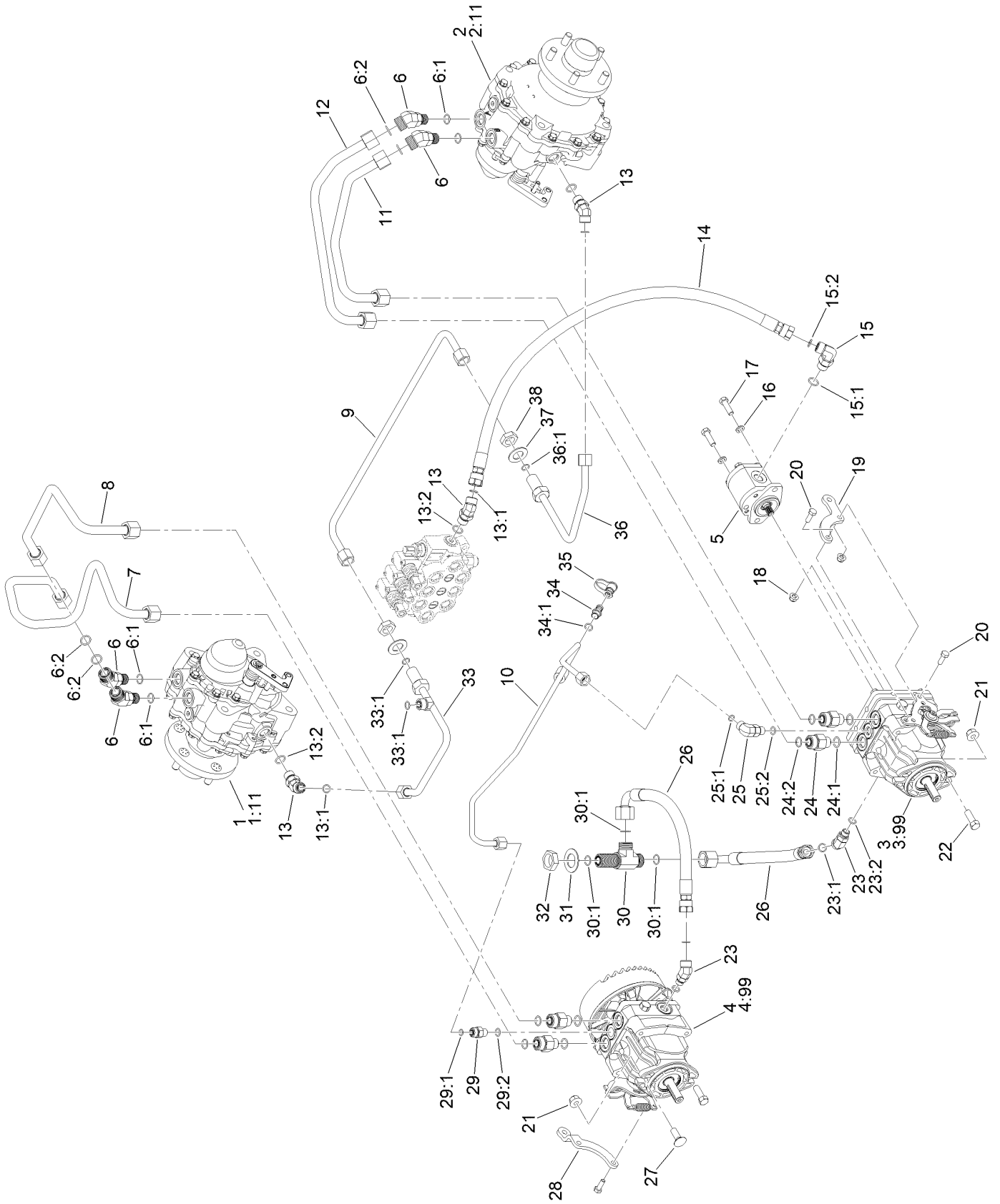

Hydraulic Drive Assembly (continued)

<i>Ref.</i>	<i>Part Number</i>	<i>Qty.</i>	<i>Description</i>	<i>Ref.</i>	<i>Part Number</i>	<i>Qty.</i>	<i>Description</i>
1	126-8133	1	Motor-HYD, RH	21	114-8417	4	Nut-HF, NI
1:11	135-5333	1	5 Stud Wheel Hub Kit	22	324-5	4	Screw-HH
2	126-8134	1	Motor-HYD, LH	23	340-96	2	Adapter
2:11	135-5333	1	5 Stud Wheel Hub Kit	23:1	237-30	1	O-Ring
3	144-7595	1	Pump-Hydro, LH 16Cc	23:2	237-42	1	O-Ring
3:99	112-4150	1	Overhaul Seal Kit	24	340-155	4	Fitting-Straight
4	144-7320	1	Pump-Hydro RH 16Cc W/ Fan	24:1	237-79	1	O-Ring
4:99	109-2866	1	Pr Overhaul Seal Kit	24:2	237-151	1	O-Ring
5	144-7596	1	HYD Gear Pump ASM	25	340-77	1	Fitting-Elbow, 90 DEG
6	340-55	4	Fitting-HYD, 45 DEG	25:1	237-22	1	O-Ring
6:1	237-79	1	O-Ring	25:2	237-42	1	O-Ring
6:2	237-65	1	O-Ring	26	144-7286	2	Hydraulic Hose ASM
7	147-6662	1	Hydraulic Tube ASM	27	3232-2	2	Screw-CARR
8	144-4548	1	Hydraulic Tube ASM	28	145-7413	1	Arm-Pump, RH
9	144-7284	1	Hydraulic Tube ASM	29	340-2	1	Fitting-Straight
10	145-2637	1	Hydraulic Tube ASM	29:1	237-22	1	O-Ring
11	144-4546	1	Hydraulic Tube ASM	29:2	237-42	1	O-Ring
12	147-6692	1	Hydraulic Tube ASM	30	94-5350	1	Fitting-Tee
13	340-101	2	Fitting-HYD, 45 DEG	30:1	237-65	3	O-Ring
13:1	237-30	1	O-Ring	31	69-9010	1	Washer
13:2	237-79	1	O-Ring	32	340-74	1	Nut-Lock, Bulkhead
14	145-2638	1	Hydraulic Hose ASM	33	145-2639	1	Hydraulic Tube ASM
15	340-98	1	Fitting-Elbow, 90 DEG	33:1	237-30	2	O-Ring
15:1	237-79	1	O-Ring	34	59-7410	1	Fitting-Diagnostic
15:2	237-30	1	O-Ring	34:1	237-42	1	O-Ring
16	106-5592	2	Spacer-Brake, Parking	35	354-79	1	Cap-Dust
17	323-7	2	Screw-HH	36	144-4542	1	Hydraulic Tube ASM
18	104-8300	4	Nut-HF, NI	36:1	237-30	1	O-Ring
19	144-4602	1	Lever, Pump	37	69-8930	2	Washer
20	322-4	4	Screw-HH	38	340-127	2	Nut-Bulkhead

5 Stud Wheel Hub Kit Assembly No. 135-5333

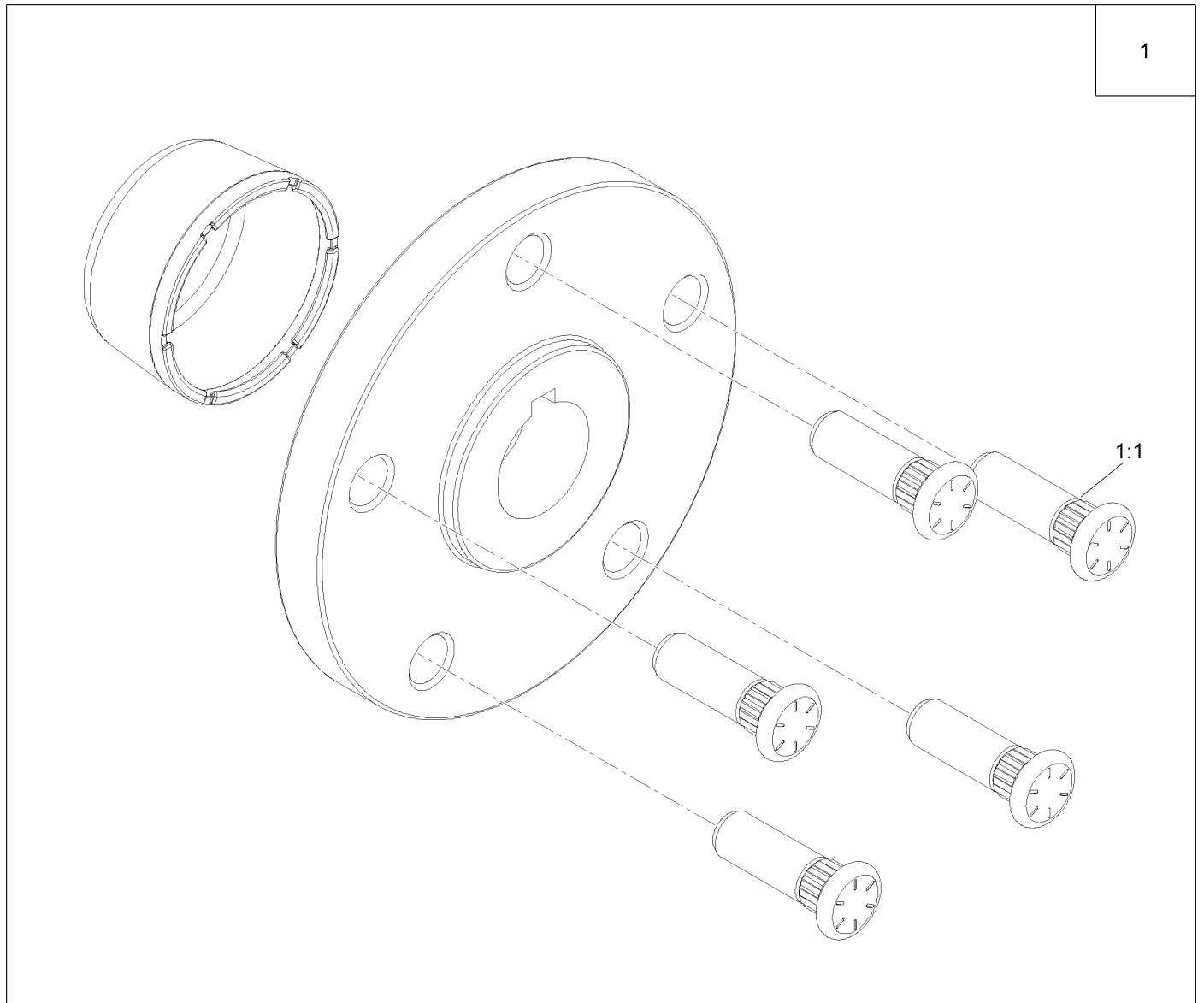

5 Stud Wheel Hub Kit Assembly No. 135-5333 (continued)

<i>Ref.</i>	<i>Part Number</i>	<i>Qty.</i>	<i>Description</i>
1	135-5332	1	Wheel Hub ASM
1:1	135-7526	5	Stud-Wheel

Hydraulic Gear Pump Assembly No. 144-7596

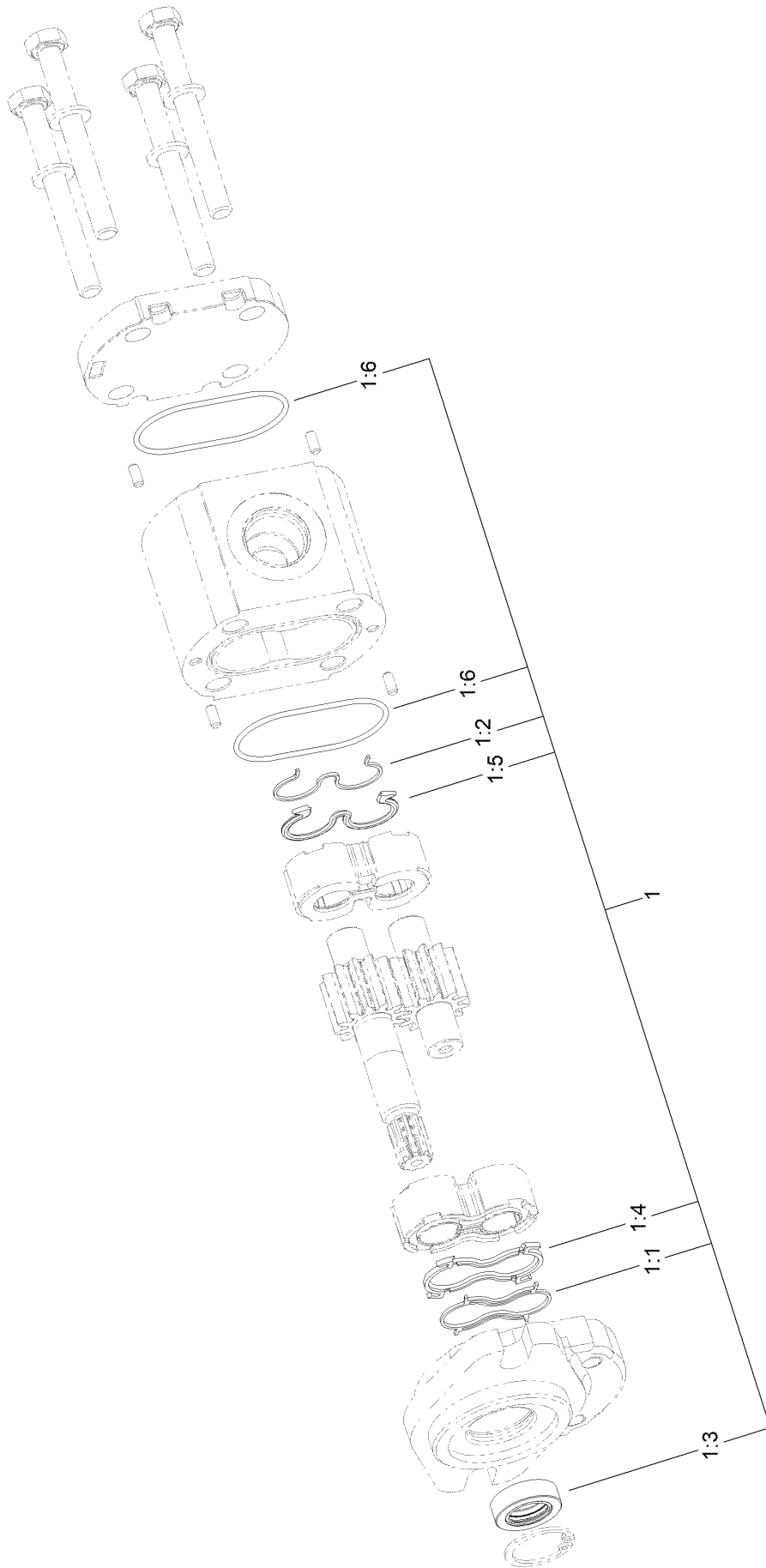

Hydraulic Gear Pump Assembly No. 144-7596 (continued)

<i>Ref.</i>	<i>Part Number</i>	<i>Qty.</i>	<i>Description</i>	<i>Ref.</i>	<i>Part Number</i>	<i>Qty.</i>	<i>Description</i>
1	112-0199	1	Seal Kit	1:4		1	Seal-Upper ●
1:1		1	Seal-Anti Extrusion ●	1:5		1	Seal ●
1:2		1	Seal-Anti Extrusion ●	1:6		2	O-Ring ●
1:3		1	Seal-Shaft ●				

● Not serviced separately

Hydraulic Control Assembly

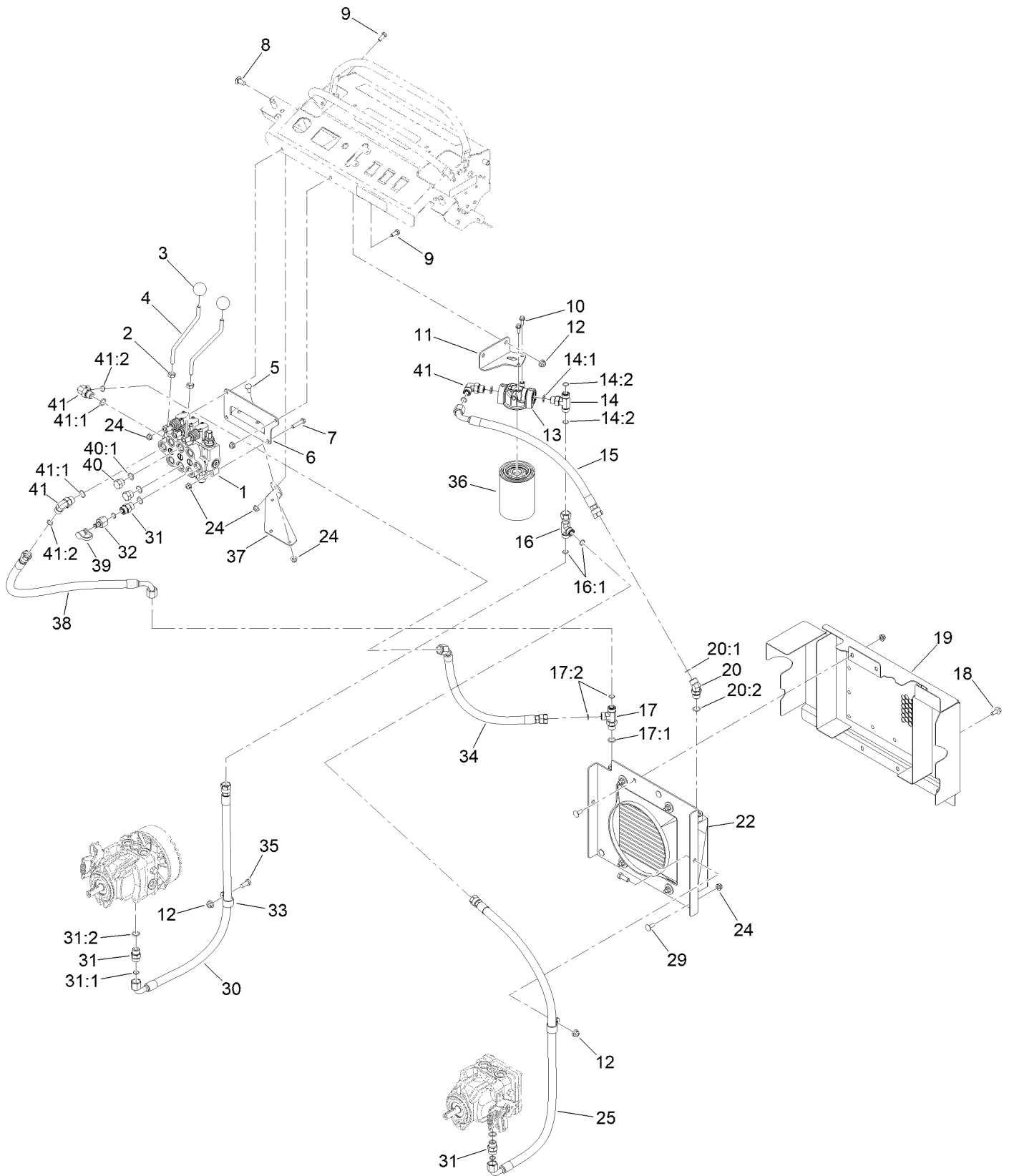

Hydraulic Control Assembly (continued)

<i>Ref.</i>	<i>Part Number</i>	<i>Qty.</i>	<i>Description</i>	<i>Ref.</i>	<i>Part Number</i>	<i>Qty.</i>	<i>Description</i>
1	144-7304	1	Valve-Control	20:1	237-30	1	O-Ring
2	33015-00	2	Nut-Hex	20:2	237-79	1	O-Ring
3	144-7313	2	Knob-Ball	22	147-6667	1	Oil Cooler ASM
4	144-7311	2	Handle-Valve, Control	24	104-8300	11	Nut-HF, NI
5	137-3061	2	Bolt-CARR	25	144-7317	1	Hydraulic Hose ASM
6	144-7629-03	1	Bracket-Mount, Joystick	29	3230-23	4	Bolt-CARR
7	120-2779	3	Screw-HH	30	144-7300	1	Hydraulic Hose ASM
8	3231-27	2	Screw-CARR	31	340-4	3	Fitting-Straight
9	137-3052	2	Screw-HH	31:1	237-30	1	O-Ring
10	3234-4	2	Screw-HHF	31:2	237-79	1	O-Ring
11	144-7295-01	1	Bracket-Filter	32	100-5616	1	Fitting
12	104-8301	4	Nut-HF, NI	33	2412-39	2	Clamp-R
13	87-8780	1	Head-Filter	34	144-7632	1	Hydraulic Hose ASM
14	340-157	1	Fitting-HYD, Tee	35	323-6	2	Screw-HH
14:1	237-79	1	O-Ring	36	86-3010	1	Filter-Oil
14:2	237-30	2	O-Ring	37	144-7630-03	1	Bracket-Support, Joystick
15	144-7301	1	Hydraulic Hose ASM	38	144-7637	1	Hydraulic Hose ASM
16	340-104	1	Fitting-Tee	39	354-79	1	Cap-Dust
16:1	237-30	2	O-Ring	40	353-550	2	Plug-HYD, HH
17	340-109	1	Fitting-Tee	40:1	237-79	1	O-Ring
17:1	237-79	1	O-Ring	41	340-98	3	Fitting-Elbow, 90 DEG
17:2	237-30	2	O-Ring	41:1	237-79	1	O-Ring
18	3234-47	2	Screw-HHF	41:2	237-30	1	O-Ring
19	147-6650-03	1	Firewall				
20	340-101	1	Fitting-HYD, 45 DEG				

Oil Cooler Assembly

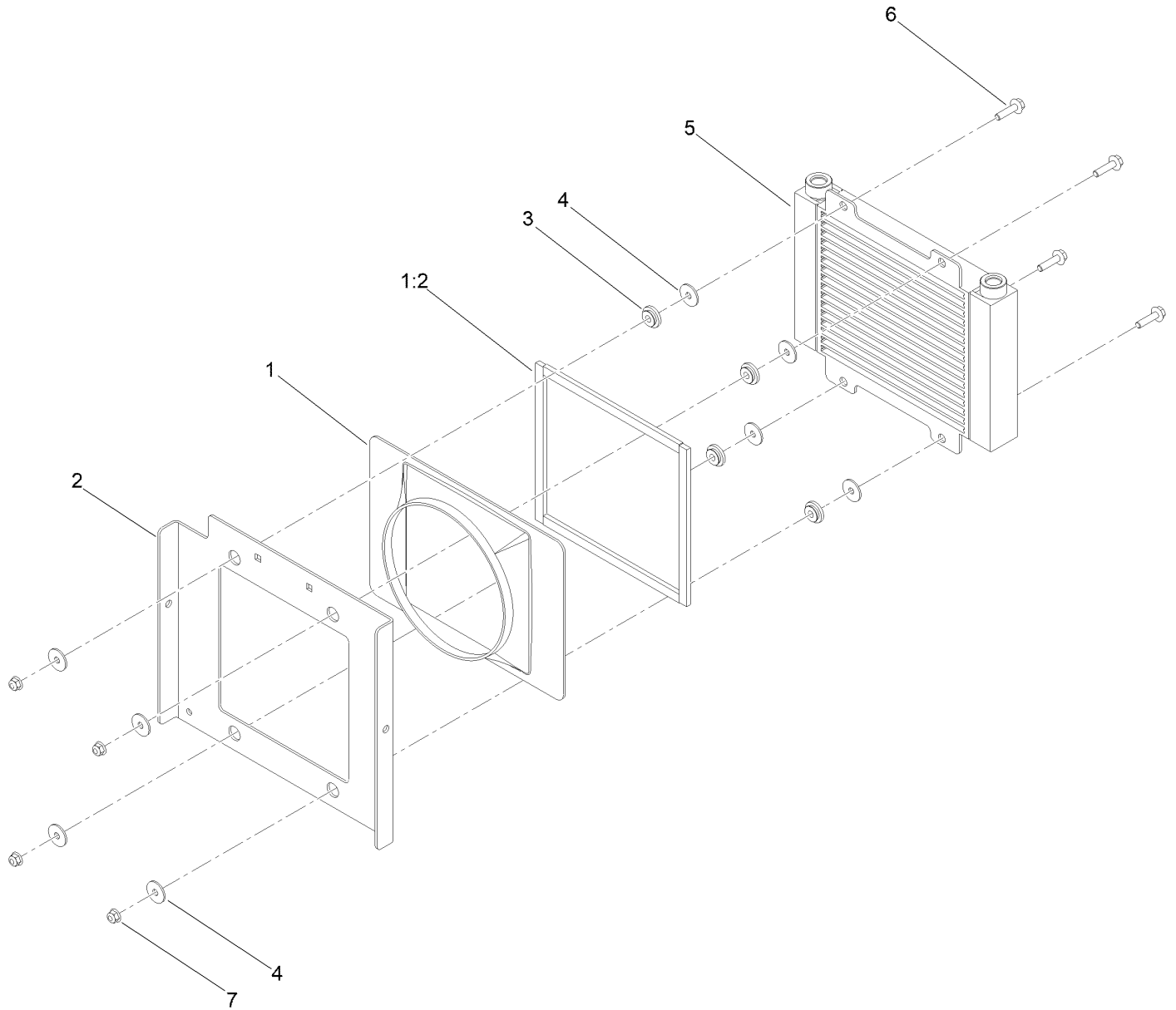

Oil Cooler Assembly (continued)

<i>Ref.</i>	<i>Part Number</i>	<i>Qty.</i>	<i>Description</i>	<i>Ref.</i>	<i>Part Number</i>	<i>Qty.</i>	<i>Description</i>
1	147-6669	1	Shroud ASM W/Seals	4	5-4460	8	Washer-Pivot
1:2	147-3314	4	Seal-Foam	5	147-6648	1	Cooler-Oil
2	147-6666-03	1	Bracket-Shroud	6	132-3837	4	Screw-HHF
3	147-6663	4	Mount	7	104-8300	4	Nut-HF, NI

Hydraulic Lift Circuit Plumbing Assembly

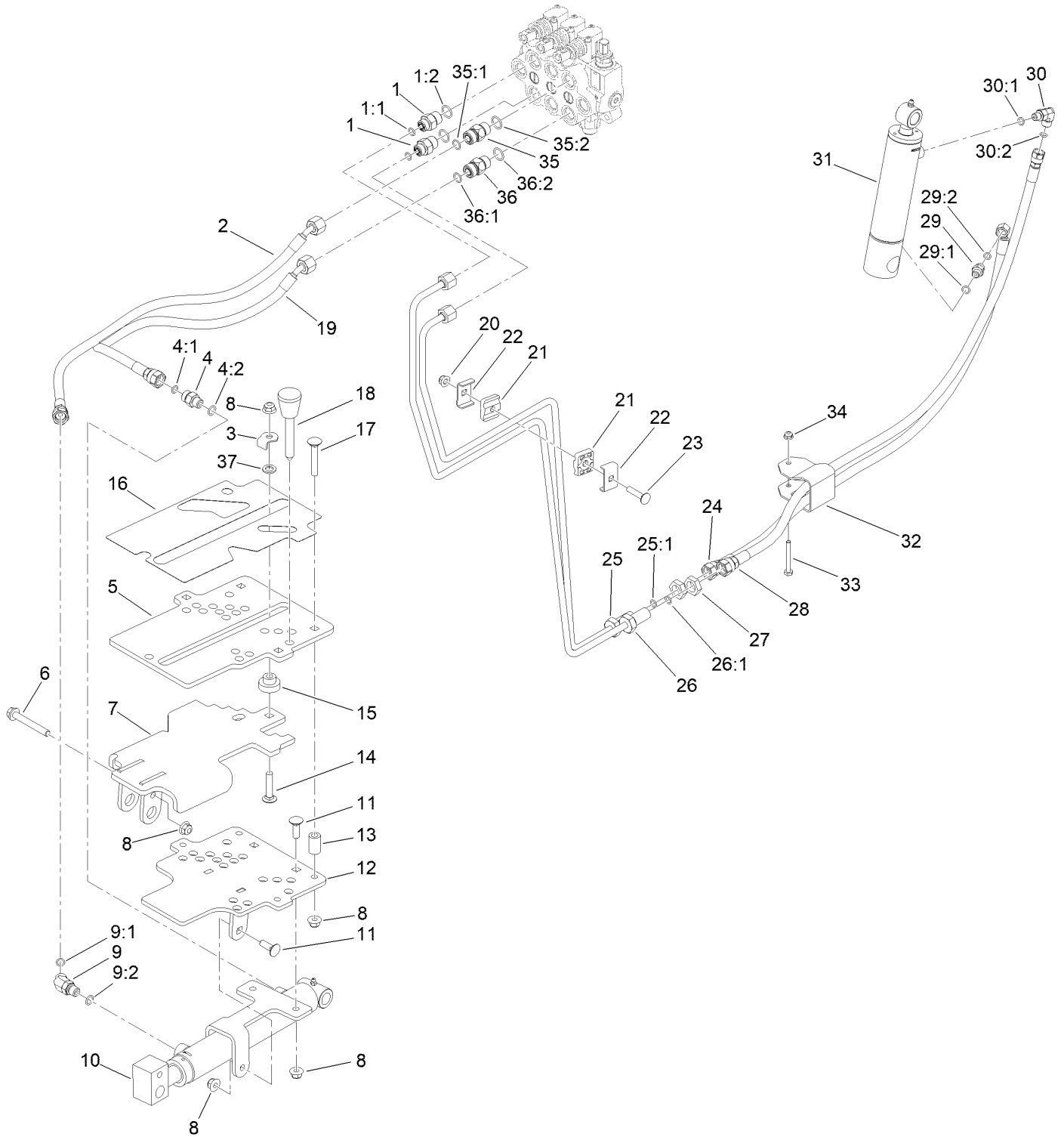

Hydraulic Lift Circuit Plumbing Assembly (continued)

<i>Ref.</i>	<i>Part Number</i>	<i>Qty.</i>	<i>Description</i>	<i>Ref.</i>	<i>Part Number</i>	<i>Qty.</i>	<i>Description</i>
1	147-3321	2	Fitting-Straight	22	119-1418	2	Plate-Clamp, Short
1:1	237-22	1	O-Ring	23	3230-4	1	Bolt-CARR
1:2	237-79	1	O-Ring	24	145-2627	1	Hydraulic Hose ASM
2	147-3328	1	Hydraulic Hose ASM	25	144-7310	1	Hydraulic Tube ASM
3	145-7412	1	Bracket-Indicator	25:1	237-22	1	O-Ring
4	340-2	1	Fitting-Straight	26	144-7309	1	Hydraulic Tube ASM
4:1	237-22	1	O-Ring	26:1	237-22	1	O-Ring
4:2	237-42	1	O-Ring	27	340-70	2	Nut-Lock
5	145-4226-03	1	Plate-Gauge, Depth	28	145-2626	1	Hydraulic Hose ASM
6	133-9682	1	Screw-Hfh	29	340-92	1	Fitting-Straight
7	145-4238-03	1	Stop-Depth	29:1	237-78	1	O-Ring
8	104-8301	10	Nut-HF, NI	29:2	237-21	1	O-Ring
9	340-87	1	Fitting-Elbow, 45 DEG	30	340-132	1	Fitting-Elbow, 90 DEG
9:1	237-22	1	O-Ring	30:1	237-78	1	O-Ring
9:2	237-42	1	O-Ring	30:2	237-21	1	O-Ring
10	145-4233	1	Cylinder-Lift	31	115-5647	1	HYD Lift Cylinder ASM
11	139-2590	4	Screw-CARR	32	147-3313-03	1	Guide-Hose
12	145-4223-03	1	Gauge-Depth	33	321-16	1	Screw-HH
13	93-6981	4	Spacer	34	104-7201	1	Nut-HF, NI
14	3231-5	1	Screw-CARR	35	147-3319	1	Fitting-Straight
15	145-7419	1	Bushing-Delrin	35:1	237-30	1	O-Ring
16	145-7379	1	Decal - Depth, Gauge	35:2	237-79	1	O-Ring
17	3231-7	4	Screw-CARR	36	147-3320	1	Fitting-Straight
18	126-5401	2	Pin-HOC	36:1	237-30	1	O-Ring
19	147-3329	1	Hydraulic Hose ASM	36:2	237-79	1	O-Ring
20	104-8300	1	Nut-HF, NI	37	106-5592	1	Spacer-Brake, Parking
21	56-7973	2	Clamp-Tube				

Hydraulic Cylinder Assembly No. 145-4233

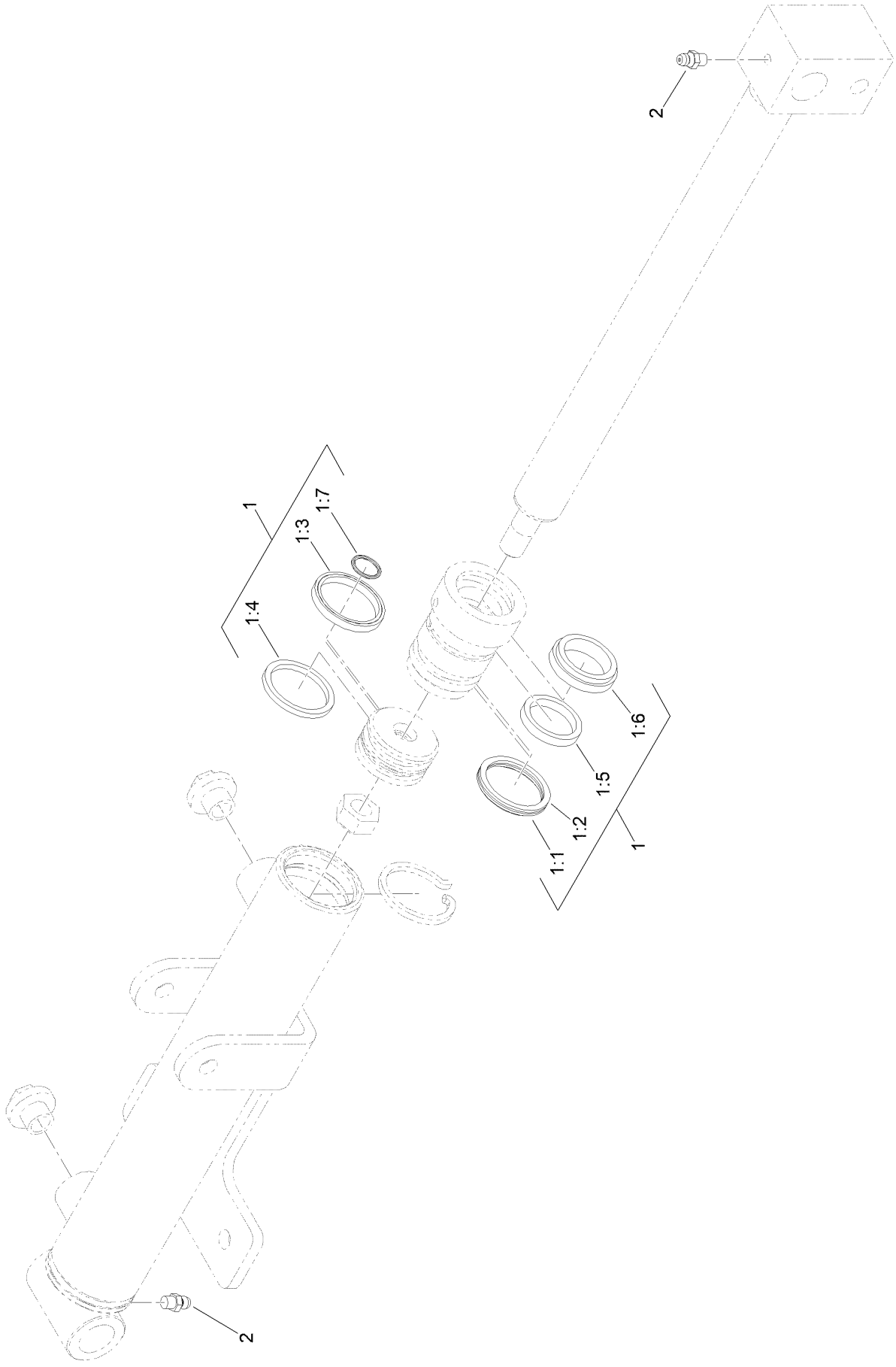

Hydraulic Cylinder Assembly No. 145-4233 (continued)

<i>Ref.</i>	<i>Part Number</i>	<i>Qty.</i>	<i>Description</i>	<i>Ref.</i>	<i>Part Number</i>	<i>Qty.</i>	<i>Description</i>
1	144-7318	1	Cylinder Repair Kit	1:5		1	Bt Seal ●
1:1		1	O-Ring ●	1:6		1	Dust Seal ●
1:2		1	Backup ●	1:7		1	O-Ring ●
1:3		1	Psp Seal ●	2	302-5	2	Fitting-Grease
1:4		1	Wear Ring-Ht ●				

● Not serviced separately

Hydraulic Lift Cylinder Assembly No. 115-5647

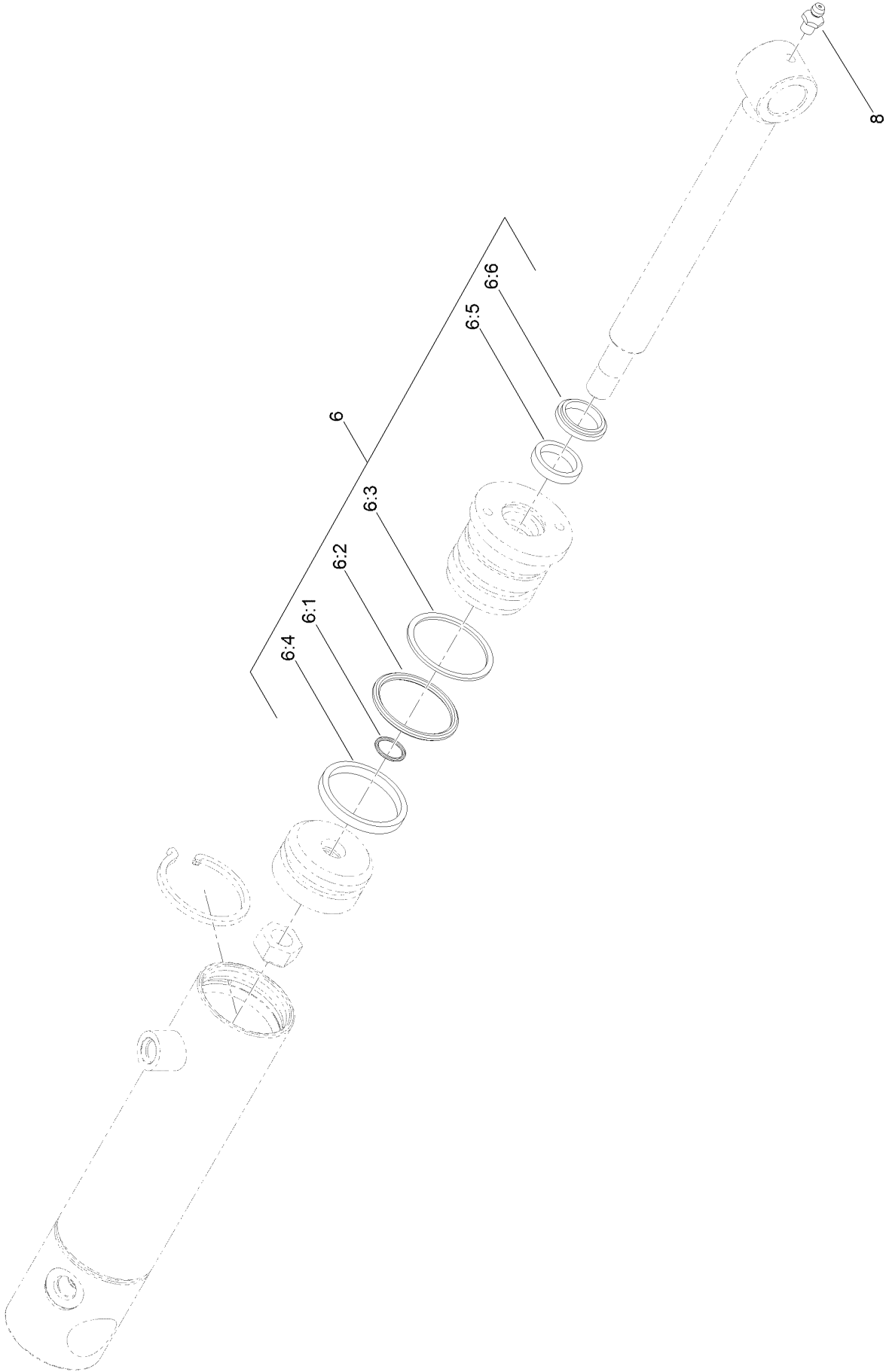

Hydraulic Lift Cylinder Assembly No. 115-5647 (continued)

<i>Ref.</i>	<i>Part Number</i>	<i>Qty.</i>	<i>Description</i>	<i>Ref.</i>	<i>Part Number</i>	<i>Qty.</i>	<i>Description</i>
6	108-4597	1	Seal Kit	6:4		1	Seal-Psp ●
6:1		1	O-Ring ●	6:5		1	Seal-Rod ●
6:2		1	O-Ring ●	6:6		1	Seal-Dust ●
6:3		1	Ring-Back Up ●	8	302-5	1	Fitting-Grease

● Not serviced separately

Electrical Assembly

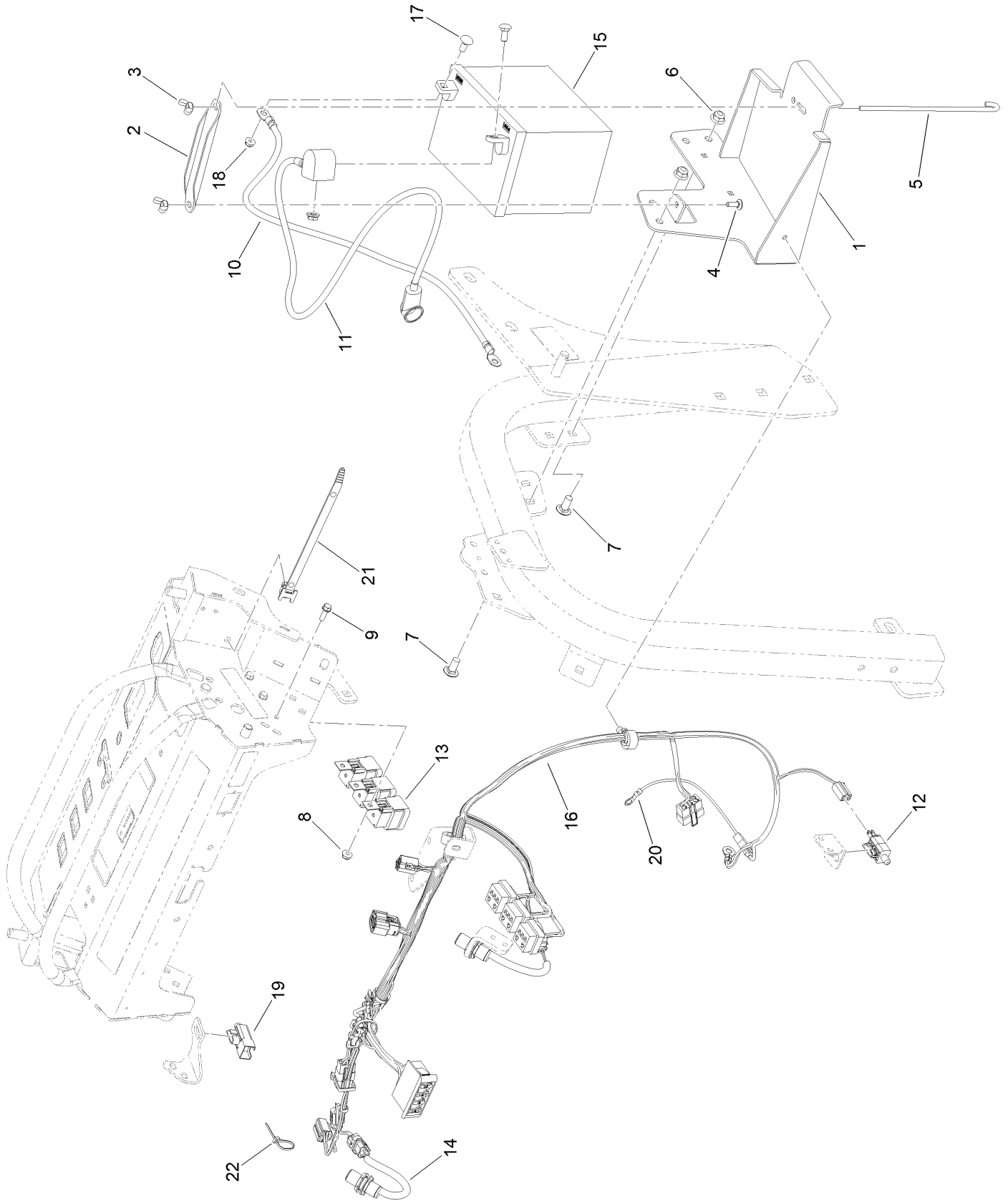

Electrical Assembly (continued)

<i>Ref.</i>	<i>Part Number</i>	<i>Qty.</i>	<i>Description</i>	<i>Ref.</i>	<i>Part Number</i>	<i>Qty.</i>	<i>Description</i>
1	144-7692-03	1	Bracket-Mount, Battery	12	122-2452	1	Harness Wire, Jumper
2	144-7169-03	1	Bracket, Tie-Down	13	99-7430	3	Relay-Mini
3	32103-22	2	Nut-Wing	14	139-7238	2	Sensor-Proximity, N.O.
4	1-807512	1	Bolt-CARR	15	104-4657	1	Battery - Wet, 12V, 350 CCA
5	1-633651	1	Bolt-Holddown	16	122-2657	1	Harness-Wire, Main
6	104-8301	4	Nut-HF, NI	17	3230-1	2	Bolt-CARR
7	3231-27	4	Screw-CARR	18	32128-20	2	Nut-HF
8	104-7201	3	Nut-HF, NI	19	99-7408	1	Switch-Reverse
9	32105-15	3	Screw-HWH	20	108-9455	1	Harness-Wire, Fusible Link
10	106-8946	1	Cable-Battery, Negative	21	32180-149	1	Tie-Button Head
11	106-8945	1	Cable-Battery, Positive	22	3290-378	1	Tie-Cable

Wire Harness Assembly No. 122-2657

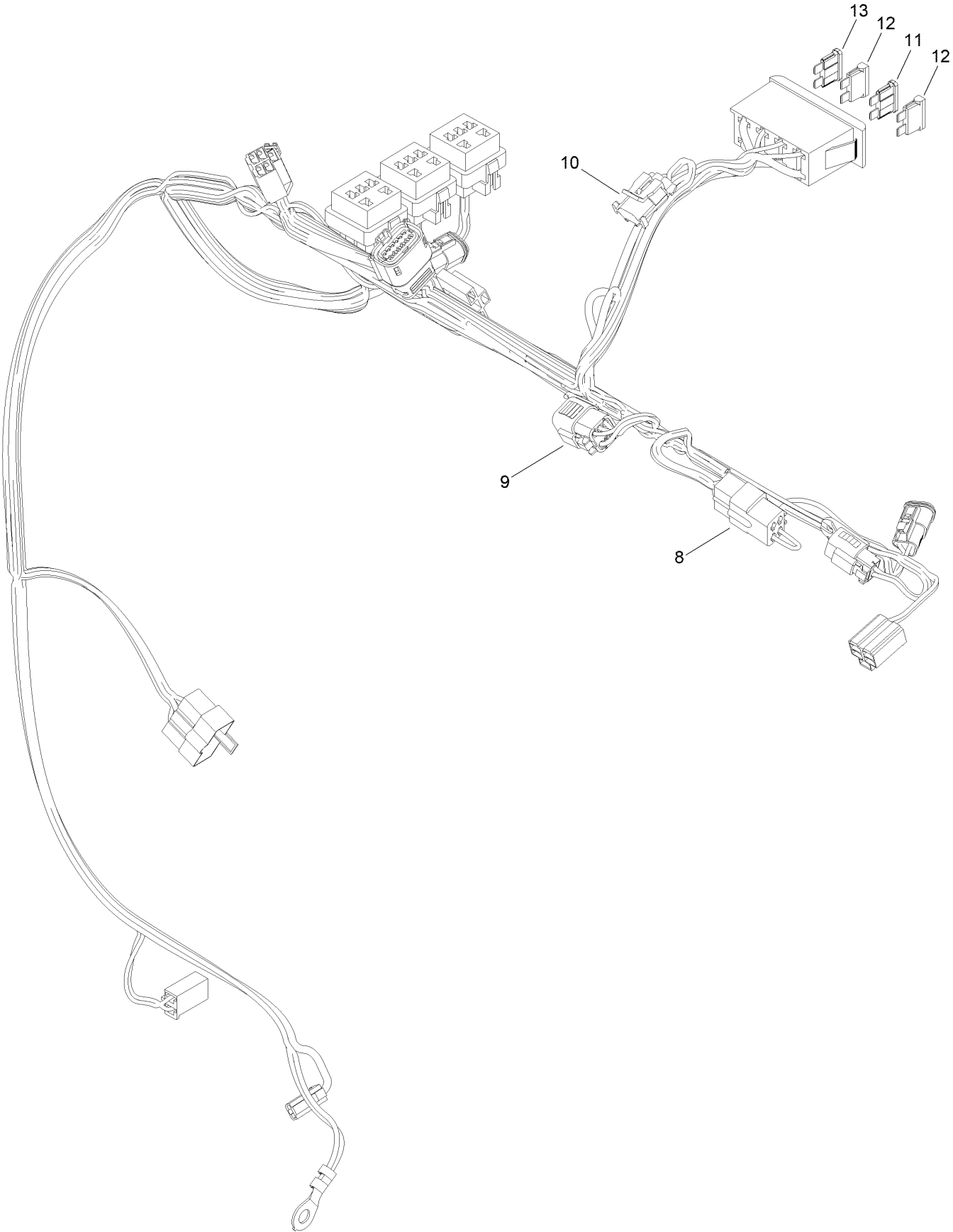

Wire Harness Assembly No. 122-2657 (continued)

<i>Ref.</i>	<i>Part Number</i>	<i>Qty.</i>	<i>Description</i>	<i>Ref.</i>	<i>Part Number</i>	<i>Qty.</i>	<i>Description</i>
8	32180-091	1	Cap-Dust, 2 Way	11	218-578	1	Fuse-Blade, 10 Amp
9	32180-156	1	Cap-Plug, 6 Way	12	109355	2	Fuse-Blade, 15 Amp
10	32180-056	1	Cap	13	109101	1	Fuse-Blade, 20 Amp

Engine, Belt and Muffler Assembly

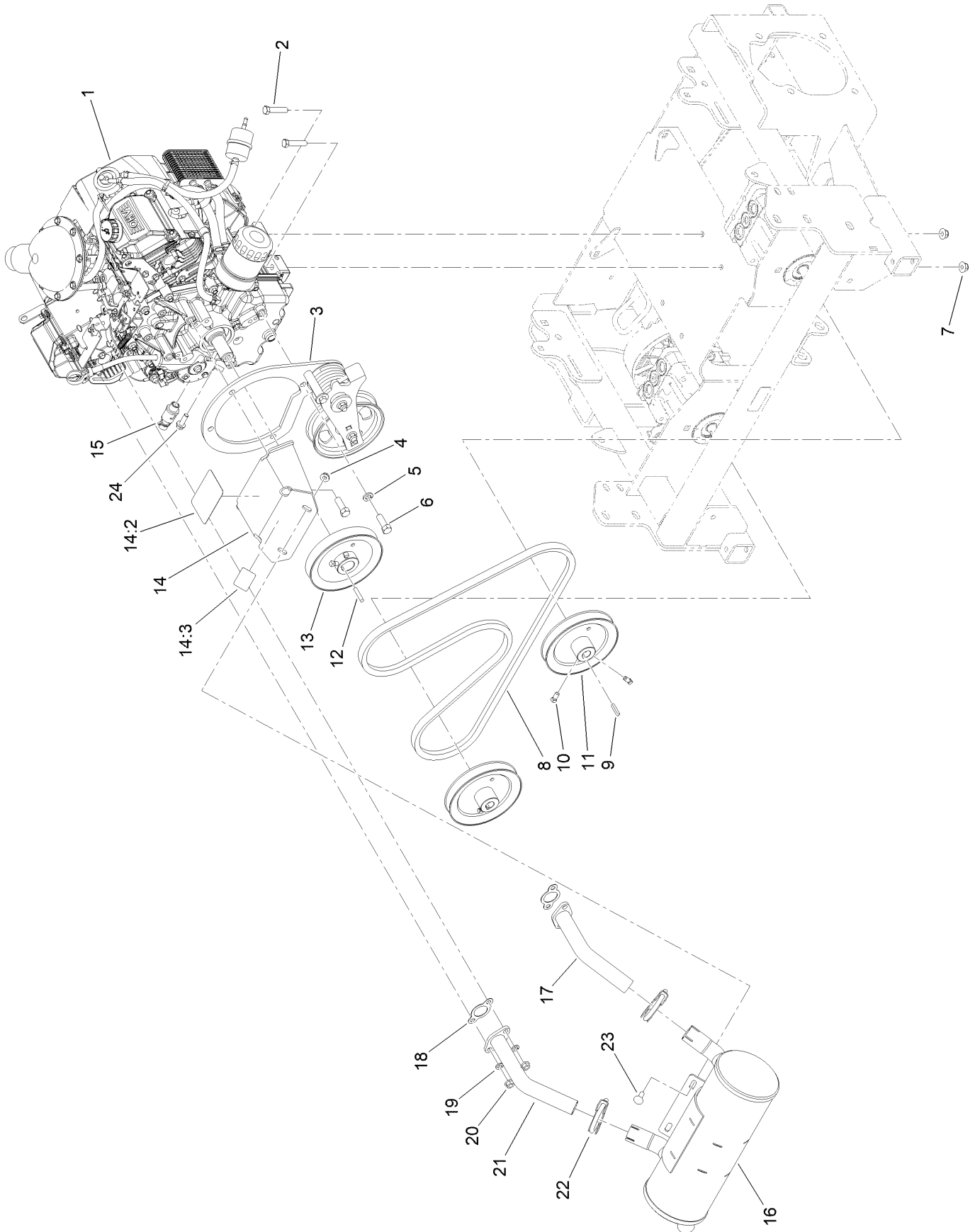

Engine, Belt and Muffler Assembly (continued)

<i>Ref.</i>	<i>Part Number</i>	<i>Qty.</i>	<i>Description</i>	<i>Ref.</i>	<i>Part Number</i>	<i>Qty.</i>	<i>Description</i>
1	133-8075	1	Engine-Kohler, Ch740-3136	14:2	145-1763	1	Decal-Belt Routing
2	323-9	4	Screw-HH	14:3	106-5517	1	Decal-Warning
3	144-4613	1	Tensioner ASM	15	120-4321	1	Valve-Drain, Oil
4	32128-35	2	Nut-HF	16	145-4161	1	Muffler
5	3253-6	2	Washer-Lock	17	145-4157	1	Header-Muffler, LH
6	324-5	4	Screw-HH	18	110-6697	2	Gasket-Exhaust
7	104-8301	4	Nut-HF, NI	19	3253-4	4	Washer-Lock
8	110-6973	1	Belt-V	20	33004-00	4	Nut-HF
9	135-7971	2	Key	21	145-4158	1	Header-Muffler, RH
10	1-803022	6	Screw-Set	22	2112-11	2	Clamp-Muffler
11	144-4642	2	Pulley-Driven	23	3234-47	2	Screw-HHF
12	13-2840	1	Key-Square	24	138-0690	1	Screw-HH
13	144-4643	1	Pulley, Drive				
14	147-3715	1	Muffler Bracket ASM W/Decals				

Tensioner Assembly

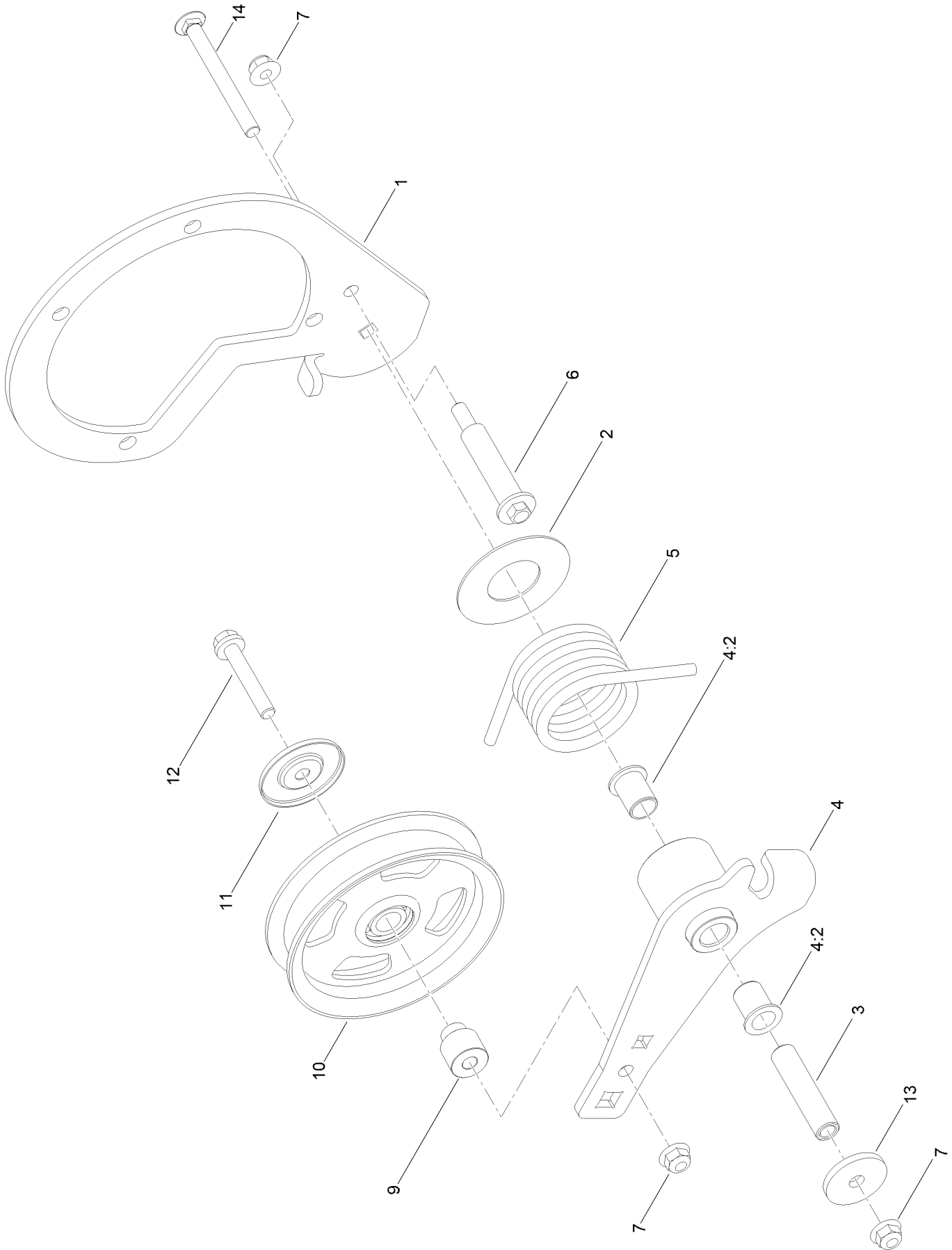

Tensioner Assembly (continued)

<i>Ref.</i>	<i>Part Number</i>	<i>Qty.</i>	<i>Description</i>	<i>Ref.</i>	<i>Part Number</i>	<i>Qty.</i>	<i>Description</i>
1	144-4612-03	1	Plate-Mount, Tensioner	7	104-8301	3	Nut-HF, NI
2	108-1926	1	Washer	9	126-7684	1	Bushing-Idler
3	144-4608	1	Spacer	10	136-5405	1	Pulley-Idler, Flat
4	144-4611	1	Idler Arm ASM	11	126-8043	1	Shield-Dust
4:2	138-2573	2	Bushing-Flange	12	100-2592	1	Screw-HHF
5	108-1921	1	Spring-Torsion	13	5-1720	1	Washer
6	112-3977	1	Bolt-Shoulder	14	3231-24	1	Screw-CARR

Fuel Tank Assembly

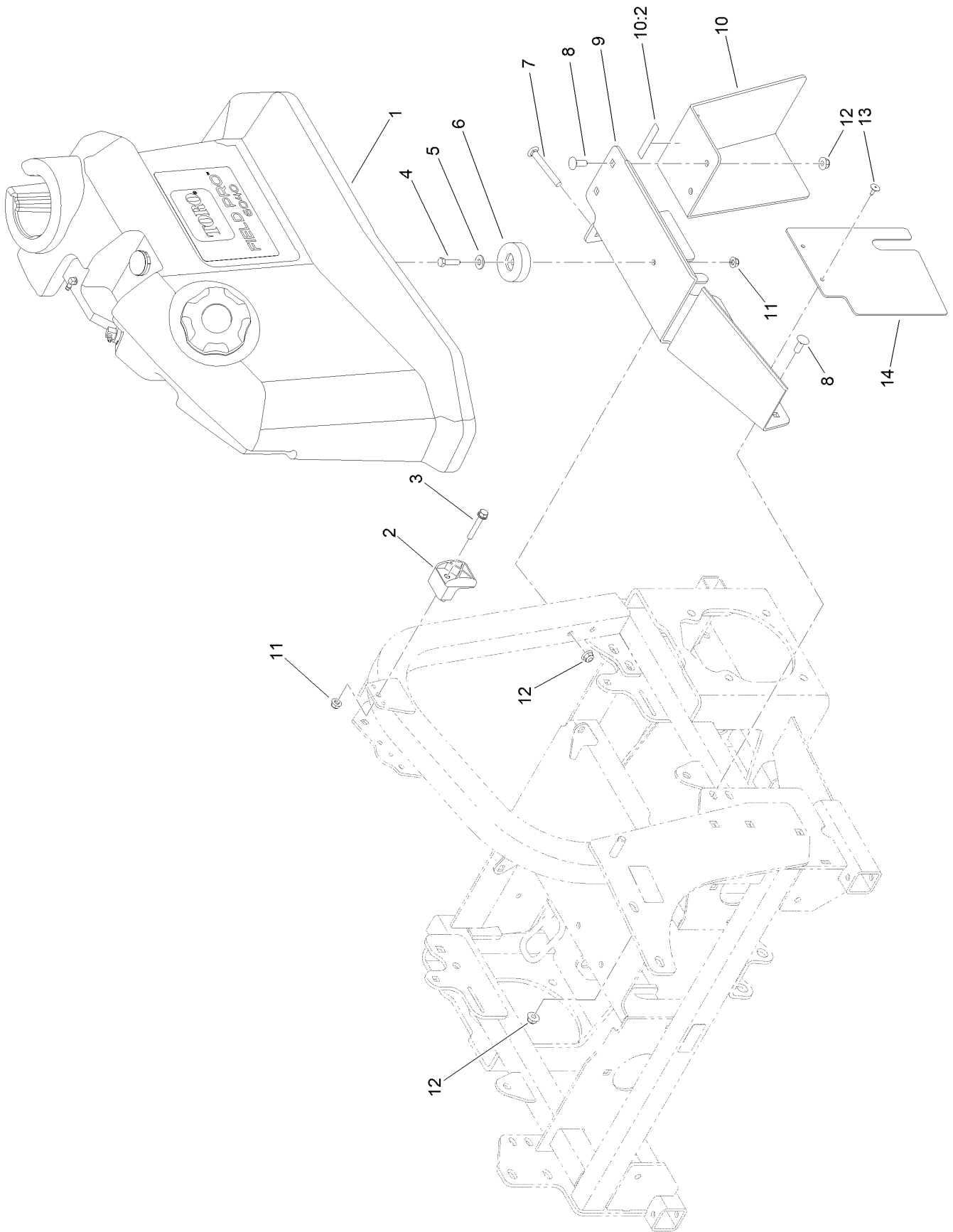

Fuel Tank Assembly (continued)

<i>Ref.</i>	<i>Part Number</i>	<i>Qty.</i>	<i>Description</i>	<i>Ref.</i>	<i>Part Number</i>	<i>Qty.</i>	<i>Description</i>
1	145-7445SP	1	Fuel Tank ASM W/Decal	9	144-7685-03	1	Bracket-Fuel Tank Mount, Lower
2	107-4543	1	Clamp	10	147-3713	1	LH Fender ASM W/Decal
3	142-6275	1	Screw-HHF	10:2	135-0328	1	Decal-Torque, Wheel Nut
4	322-6	1	Screw-HH	11	104-8300	2	Nut-HF, NI
5	3256-3	1	Washer-Flat	12	104-8301	6	Nut-HF, NI
6	108-1605	1	Bumper-Recess	13	3269-20	2	Rivet-Pop
7	3231-42	2	Screw-CARR	14	147-3305	1	Flap-Cover, Side
8	3231-22	4	Screw-CARR				

Fuel Tank Assembly No. 145-7445SP (continued)

<i>Ref.</i>	<i>Part Number</i>	<i>Qty.</i>	<i>Description</i>
1		1	Fuel Tank ASM ●
1:2	135-4801	1	Cap-Fuel, Ratcheting
1:3	145-7439	1	Gauge-Fuel
1:3:1	119-0508	1	Seal
1:3:2	117-8404	1	Dial-Gauge

<i>Ref.</i>	<i>Part Number</i>	<i>Qty.</i>	<i>Description</i>
1:4	46-6560	2	Bushing
1:5	117-7400	1	Fitting-Plastic
1:6	145-4220	1	Fuel Tube ASM
2	145-1776	1	Decal-Field Pro 6040

● Not serviced separately

Engine Air Cleaner and Fuel System Assembly

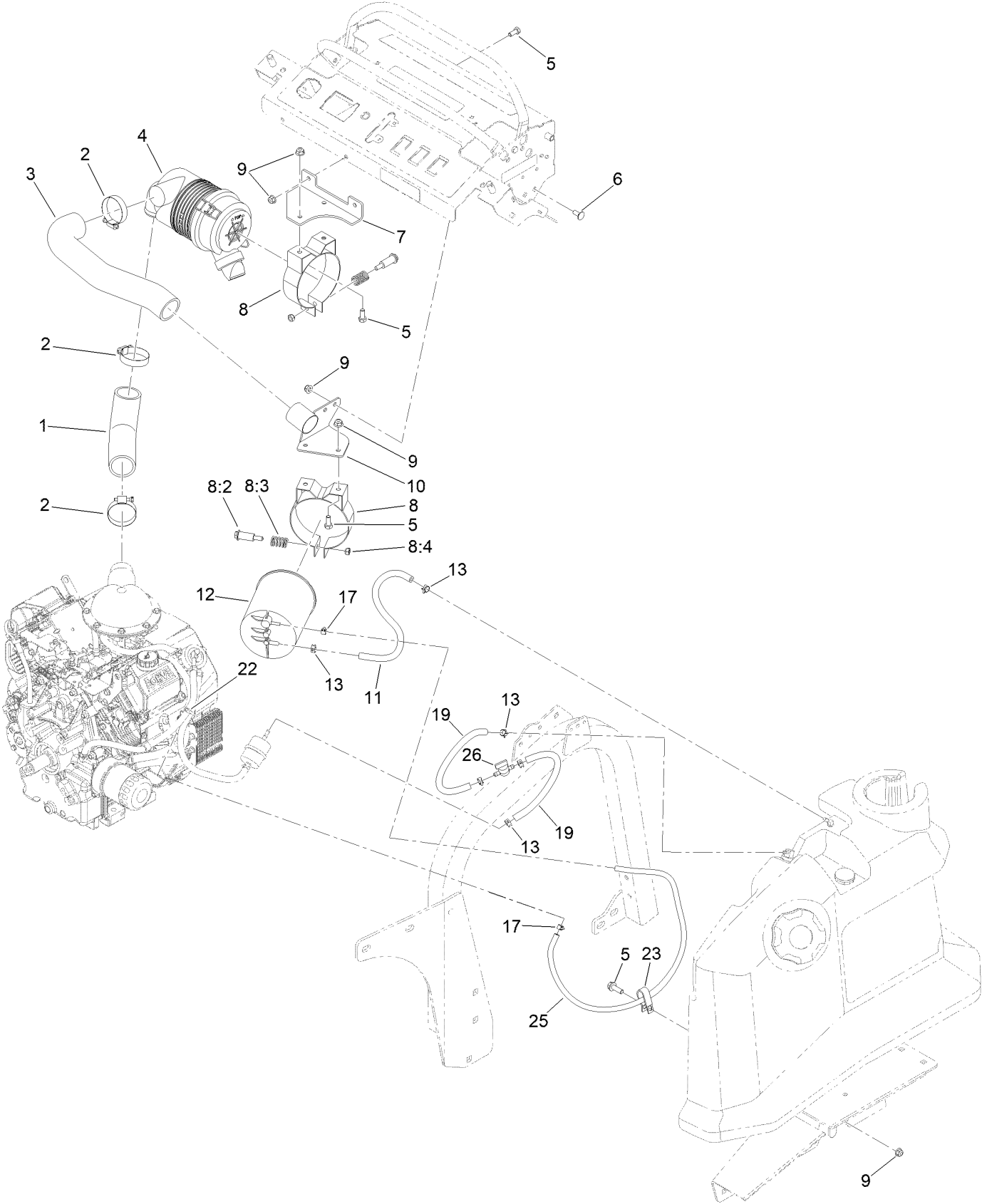

Engine Air Cleaner and Fuel System Assembly (continued)

<i>Ref.</i>	<i>Part Number</i>	<i>Qty.</i>	<i>Description</i>	<i>Ref.</i>	<i>Part Number</i>	<i>Qty.</i>	<i>Description</i>
1	144-7168	1	Hose-Intake, Air	9	104-8300	7	Nut-HF, NI
2	2412-92	3	Clamp-Hose	10	147-3317-01	1	Carb Canister Mount ASM
3	147-3312	1	Hose-Inlet ASM	11	110-4895	1	Hose-Fuel
4	117-9989	1	Air Cleaner ASM	12	116-1442	1	Canister-Carbon, 1200Cc
5	322-3	7	Screw-HH	13	2412-98	6	Clamp-Hose
6	3230-23	2	Bolt-CARR	17	2412-146	2	Clamp-Hose
7	144-7167-03	1	Bracket-Mount, Air-Filter	19	110-3447	2	Hose-Fuel
8	93-2191	2	Air Cleaner Mounting Band ASM	22	3290-378	1	Tie-Cable
8:2	94-3653	1	Bolt	23	92-5753	1	Clamp-Hose
8:3	94-3654	1	Spring	25	140-4956	1	Hose-Fuel
8:4	33024-00	1	Nut-Lock, NI	26	1-603770	1	Valve-Fuel

Air Cleaner Assembly No. 117-9989

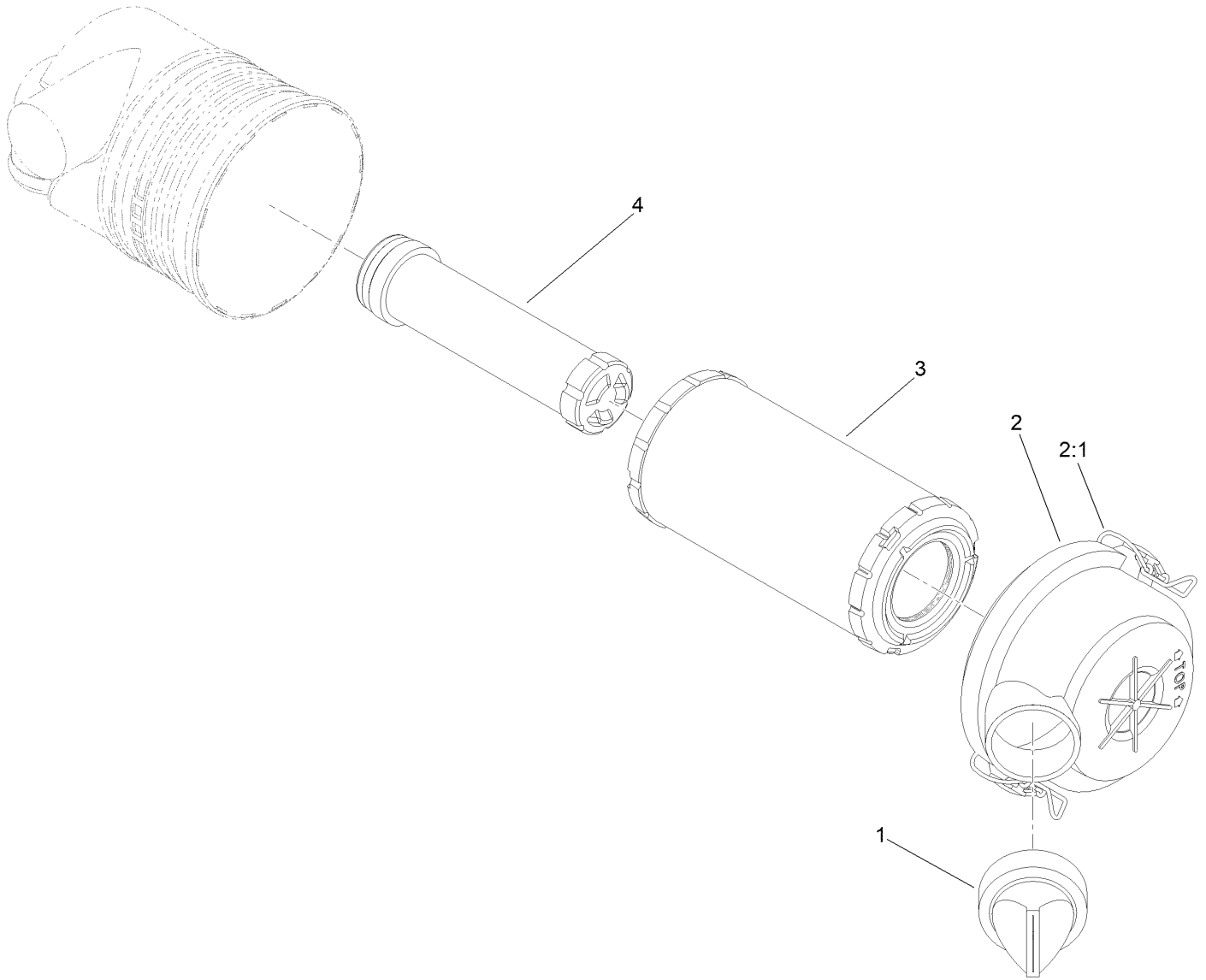

Air Cleaner Assembly No. 117-9989 (continued)

<i>Ref.</i>	<i>Part Number</i>	<i>Qty.</i>	<i>Description</i>	<i>Ref.</i>	<i>Part Number</i>	<i>Qty.</i>	<i>Description</i>
1	87-9400	1	Valve-Vacuator	3	108-3811	1	Filter-Air V-Twin HD
2	94-3652	1	Cover ASM	4	98-2982	1	Filter-Element, Safety
2:1	1-643283	2	Latch-Cleaner, Air				

Rear Frame Assembly (continued)

<i>Ref.</i>	<i>Part Number</i>	<i>Qty.</i>	<i>Description</i>	<i>Ref.</i>	<i>Part Number</i>	<i>Qty.</i>	<i>Description</i>
1	147-3708	1	Rear Frame ASM W/Decals	9	104-8300	3	Nut-HF, NI
1:2	145-1777	1	Decal-Danger, Bystanders	10	140-6323	1	Pin
1:3	67-7310	1	Decal	11	3230-22	1	Screw-CARR
1:4	58-6520	1	Decal-Grease	12	145-4178-03	1	Lift-Shaft
2	145-1811	4	Plug, Square	13	256-132	4	Bushing-Flange
3	325-11	6	Screw-HH	14	145-4175-03	2	Hub-Lift
4	99-5107	10	Nut-Lock	15	325-11	4	Screw-HH
5	117-9739	1	Pad-Cushion	16	145-7381-03	1	Bracket-Lift Extra
6	302-5	1	Fitting-Grease	17	3230-2	2	Bolt-CARR
7	3256-23	4	Washer-Plain	18	107-3395	2	Washer-Hardened
8	121-7999	4	Screw-HH	19	147-3750-03	2	Plate-Tie Down

Rear Attachment Mount Assembly

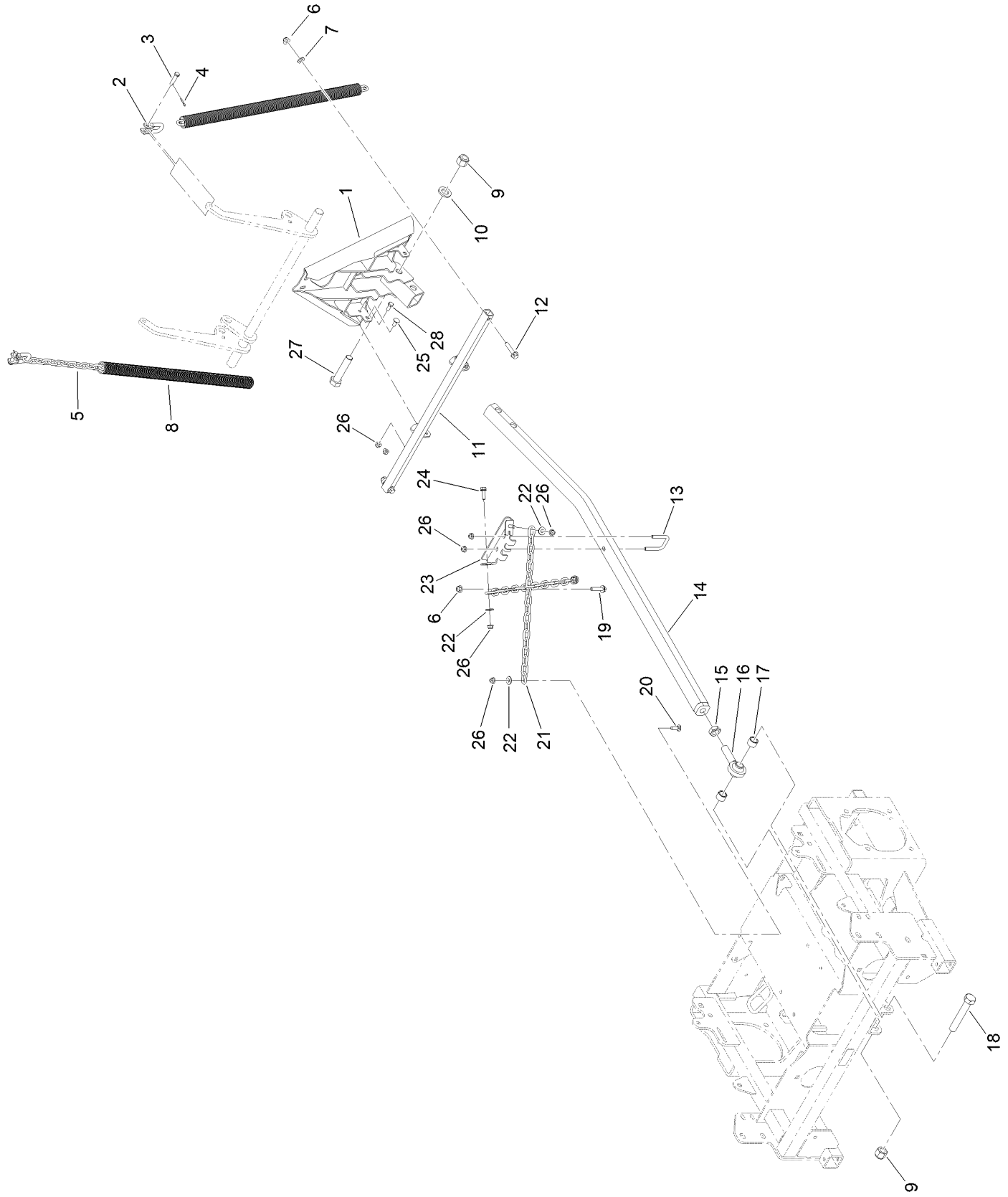

Rear Attachment Mount Assembly (continued)

<i>Ref.</i>	<i>Part Number</i>	<i>Qty.</i>	<i>Description</i>	<i>Ref.</i>	<i>Part Number</i>	<i>Qty.</i>	<i>Description</i>
1	144-7662-03	1	Adapter	15	3220-7	1	Nut-Jam
2	5-2942	2	Shackle	16	127-4139	1	Bearing-End, Rod
3	283-10	2	Pin-Clevis	17	127-4138	2	Spacer
4	3272-10	2	Pin-Cotter	18	328-8	1	Screw-HH
5	145-7421	2	Chain-Proof 25 Link	19	3234-18	1	Screw-HHF
6	104-8301	3	Nut-HF, NI	20	3230-2	2	Bolt-CARR
7	3256-24	2	Washer-Plain	21	125-5127	2	Chain-Proof, 18 Link
8	145-7422	2	Sleeve-Chain	22	3256-3	4	Washer-Flat
9	3296-51	2	Nut-Lock, NI	23	125-6476-03	1	Bracket-Stop, Tow
10	105-4551	1	Washer-Flat	24	3234-29	2	Screw-HHF
11	145-1809-03	1	Bar-Lift	25	3230-23	2	Bolt-CARR
12	140-4808	2	Screw-HHF	26	104-8300	10	Nut-HF, NI
13	301950	1	U-Bolt-Square	27	328-5	1	Screw-HH
14	144-7660-03	1	Bar-Draw	28	322-3	2	Screw-HH

Attachments and Accessories

For 08839 Field Pro 6040

Product Name	Model/Part
Carbide Tine Toolbar	08846
Mid-Mount Tool Carrier	08854
Box Blade Accessory Tool Holder Kit	08861
Planer Blade Kit	08862
Field Edger	08863
Root Cutter	08864
Laser Level Installation Kit	08865
Weight Mount Kit	08869
Weeder Tine Toolbar	08900
Box Blade Extension Kit (LH and RH)	08901
Field Roller	08902
Segmented Wide Rear Broom	08903
Draw Bar Hitch Kit	08904
Rear Storage and Tool Holder Kit	08905
Work Lights	08906
Sunshade	08909
Sprayer	08910
Premium Transmission/Hydraulic Tractor Fluid (55 Gallon Drum)	108-1183
Premium Transmission/Hydraulic Tractor Fluid (5 Gallon Pail)	108-1184
Premium All Purpose Grease (Tube)	108-1190
Premium Engine Oil 10w30 (55 Gallon Drum)	121-6392
Premium Engine Oil 10w30 (5 Gallon Pail)	121-6393
Wireless Hourmeter Kit	147-6630
Exhaust Silencer Screen	93-9911

Notes:



Count on it.