



LED Work Light Kit

Model No. 161-6717

Installation Instructions

Installation

Loose Parts

Use the chart below to verify that all parts have been shipped.

Description	Qty.	Use
No parts required	–	Prepare the machine.
LED light	2	Install the kit.
Bolt (5/16 x 3/4 inch)	2	
Nut (5/16 inch)	2	
Rocker switch	1	
Accessory-relay harness	1	
Light harness	1	
Cable tie	3	



⚠ WARNING

While maintenance or adjustments are being made, someone could start the engine. Accidental starting of the engine could seriously injure you or other bystanders.

Remove the key from the ignition switch and engage the parking brake before you do any maintenance.

Note: Determine the left and right sides of the machine from the normal operating position.

Note: Park the machine on a level surface. Ensure that all moving parts have stopped, the parking brake is engaged, and the key has been removed. Allow the machine to cool before starting these instructions.

Preparing the Machine

1. Park the machine on a level surface.
2. Disengage the drives and engage the parking brake.
3. Shut off the engine and remove the ignition key.
4. Wait for all moving parts to stop.
5. Allow machine components to cool before performing maintenance.
6. Disconnect the negative battery cable.
7. If applicable, lower the platform.
8. Lift and lock the thigh pad into place.

Installation Instructions

1. Install the 2 LED lights to the front of the machine using 2 bolts (5/16 x 3/4 inch) and 2 nuts (5/16 inch).

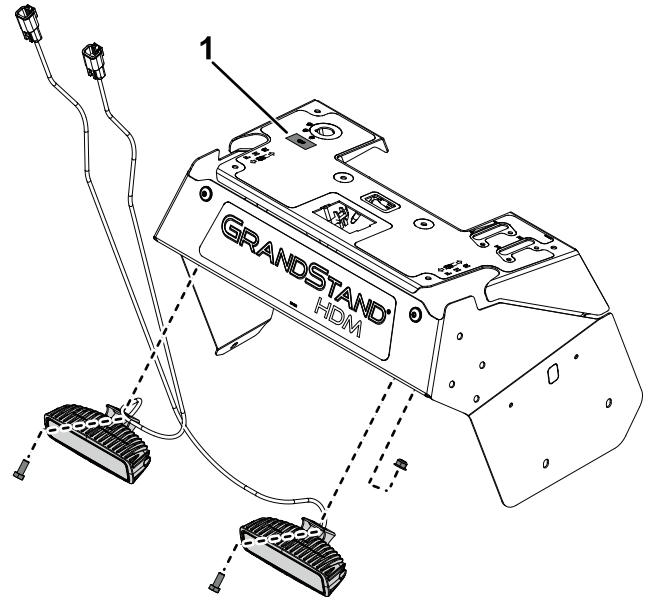

Figure 1

g481435

1. Control panel knockout

2. Carefully cut the control panel decal where the light symbol is shown (Figure 1). Remove the knockout from control panel.
3. Route the light harness as shown below.

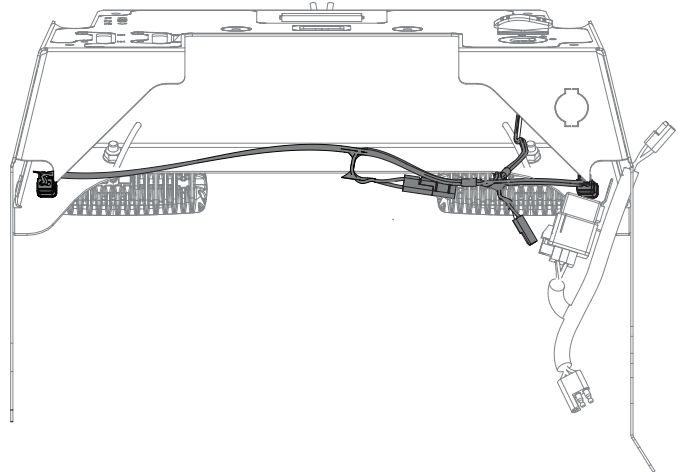

Figure 2

g481521

4. Place the rocker switch into control panel cutout and connect it to the light wire harness connector. Ensure that the connectors are fully inserted onto the terminals.

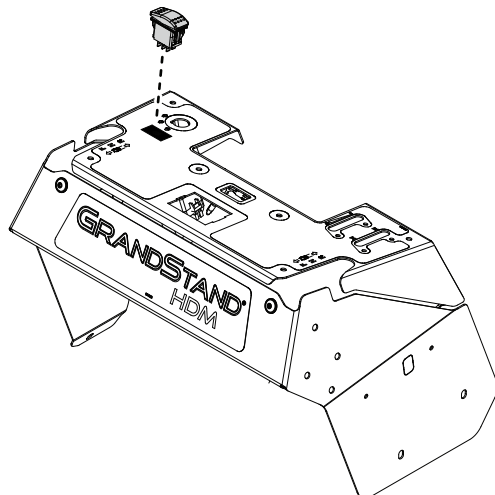

Figure 3

g481437

-
5. Carefully snap the switch into the cutout.
 6. Loosely cable tie the light harness to the main harness.
 7. Connect the light and accessory-relay harness to the main harness and use cable ties to secure it to the frame.
 8. Coil any excess wire as necessary and use the remaining cable ties to secure the light harness to the machine.
 9. Connect the negative battery cable.
 10. Lower the thigh pad.



Count on it.