



Z149

Z-Master[®] with 52in Side Discharge Mower

Model No. 74179—220010043 and Up

Parts Catalog

Ordering Replacement Parts

To order replacement parts, please supply: the part number, the quantity, and the description of each part desired.

Understanding Reference Numbers

Each identified part in an illustration has a reference number. The reference number for a part also appears in the parts list, along with other information about the part.

This catalog uses two special reference number formats, one to indicate parts in a service assembly and another to indicate the quantity of a given part in an illustration.

Service Assembly Reference Numbers

Parts in service assemblies have reference numbers in the form **a:b**. The **a** represents the reference number of the entire service assembly and the **b** represents a sequential number unique to each part within the service assembly.

For example, a wheel assembly might be identified by reference number **6**, the tire by **6:1**, the valve by **6:2**, and the wheel by **6:3**. When you order the assembly identified by reference number **6**, you receive all parts identified by reference numbers **6:1**, **6:2**, and **6:3**. However, you may also order any part individually.

Reference numbers of this type appear in illustrations and in part lists.

Reference Numbers Indicating Quantity

In an illustration, if a reference number indicates more than one part, the reference number has the form **nX y**. The **n** represents the quantity of the part, the **X** is the multiplication symbol, and the **y** represents the reference number.

For example, in an illustration, the reference number **2X 37** means that two of the parts identified by reference number **37** are indicated.

Contents

| Description | Page | Description | Page |
|--|-------------|--|-------------|
| Front Frame Assembly | 4 | Valve/Camshaft Assembly – Kawasaki | |
| Height of Cut Assembly | 6 | FH601V-AS23 | 23 |
| Main Frame Assembly | 7 | Valve/Camshaft Assembly – Kawasaki | |
| Fuel System Assembly | 8 | FH601V-AS23 | 24 |
| Parking Brake System Assembly | 9 | Cooling Equipment Assembly – Kawasaki | |
| Motion Control System Assembly | 10 | FH601V-AS23 | 25 |
| Hydraulic System Assembly | 11 | Cooling Equipment Assembly – Kawasaki | |
| Pump, Idler and Belt Assembly | 12 | FH601V-AS23 | 26 |
| Engine and Clutch Assembly | 13 | Electric Equipment Assembly – Kawasaki | |
| Deck Assembly | 14 | FH601V-AS23 | 27 |
| Deck Spindle Assembly | 15 | Electric Equipment Assembly – Kawasaki | |
| Idler, Pulley/Lift Strut, Chain Assembly | 16 | FH601V-AS23 | 28 |
| Electrical System Assembly | 17 | Control Equipment Assembly – Kawasaki | |
| Electrical Schematic | 18 | FH601V-AS23 | 29 |
| Piston/Crankshaft Assembly – Kawasaki | | Control Equipment Assembly – Kawasaki | |
| FH601V-AS23 | 19 | FH601V-AS23 | 30 |
| Lubrication Equipment Assembly – Kawasaki | | Carburetor Assembly–Kawasaki FH601V-AS23 | 31 |
| FH601V-AS23 | 20 | Carburetor Assembly–Kawasaki FH601V-AS23 | 32 |
| Cylinder/Crankcase Assembly – Kawasaki | | Fuel Tank/Fuel Valve Assembly–Kawasaki | |
| FH601V-AS23 | 21 | FH601V-AS23 | 33 |
| Cylinder/Crankcase Assembly – Kawasaki | | Starter/Decal – Kawasaki FH601V-AS23 | 34 |
| FH601V-AS23 | 22 | | |

Accessories

| Description | Model / Part No. | Description | Model / Part No. |
|--|-------------------------|--------------------------------|-------------------------|
| Recycler Kit | 59225 | Striping Kit | 30121 |
| Bahaia Mulch Kit | 59227 | High Suspension Seat | 99-8522 |
| High Sail Blades | | Z-Stand Kit | 105-1621 |
| (3 required for improved bagging) | 56-2390 | Muffler Kit | 105-3636 |
| Atomic Blades | | Hitch Kit | 99-8924 |
| (3 required for improved mulching) | 104-1301 | Roll-Over-Protection Kit | 79470 |
| Steel Bagger | 30107 | | |

Part Description Abbreviations

Part descriptions in this catalog may include the following abbreviations.

| Abbreviation | Meaning | Abbreviation | Meaning |
|---------------------|-----------------------------------|---------------------|-------------------------|
| AR | as required | HYD | hydraulic |
| ASM | assembly | INC | incorporated |
| CARR | carriage | LH | left hand |
| DEG | degrees | NI | nylon insert |
| FH | flat head | PPH | Phillips pan head |
| GA | gauge | PTH | Phillips truss head |
| HF | hex flange | PTO | power take off |
| HH | hex head | RH | right hand |
| HHF | hex head flange | SFH | slotted fillister head |
| HLH | hex lag head | SHH | slotted hex head |
| HJ | hex jam | SQH | square head |
| HOC | height-of-cut | SHWH | slotted hex washer head |
| HS | hex socket | SPH | slotted pan head |
| HSBH | hex socket button head | SRH | slotted round head |
| HSFH | hex socket flat head | STD | standard |
| HSH | hex socket head | TAP | self tapping |
| HWH | hex washer head | TTH | Torx truss head |
| HWHTF | hex washer head thread forming | WH | wing head |

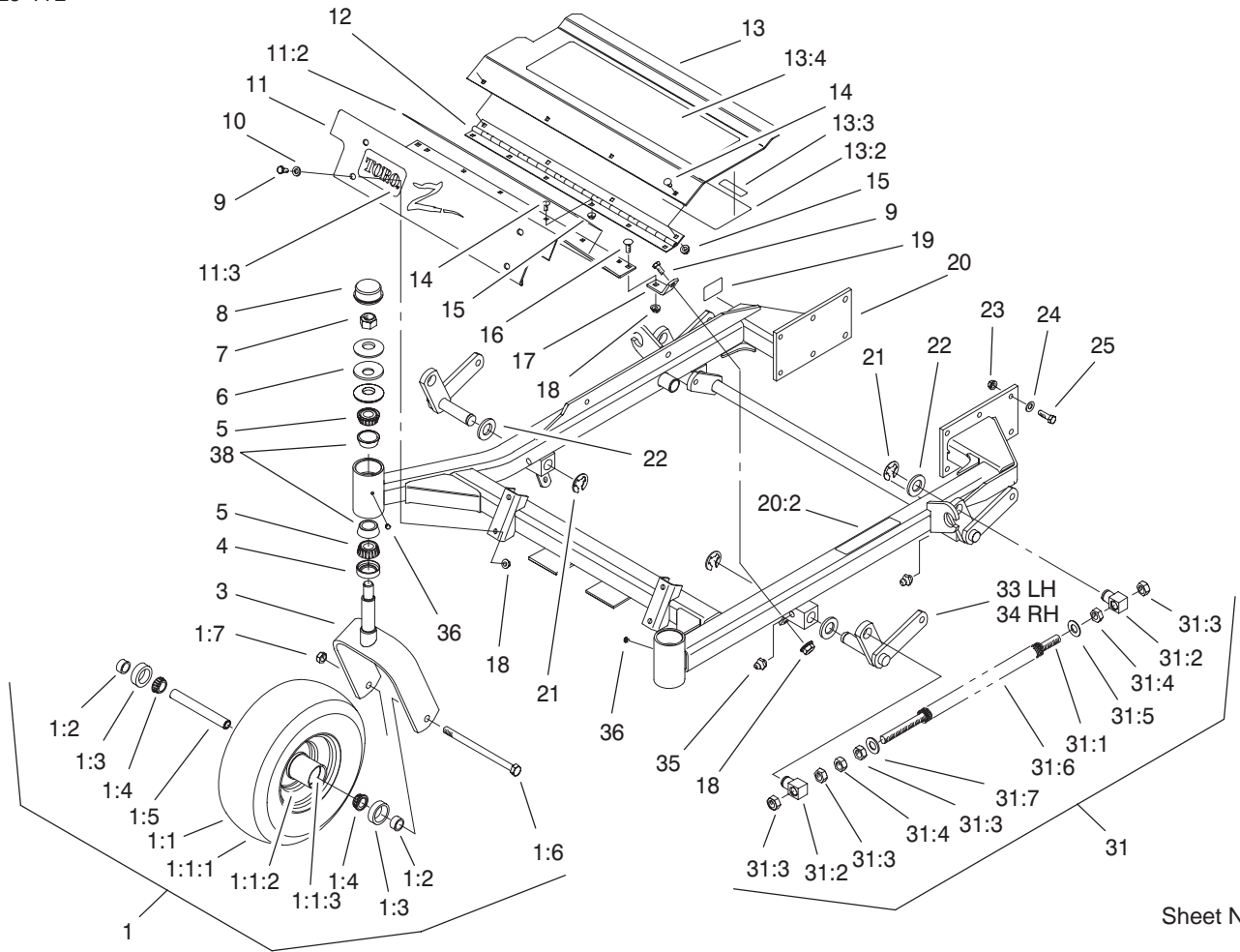

Sheet No.: 2

Front Frame Assembly

| Ref. No. | Part No. | Qty. | Description |
|----------|-------------|------|----------------------|
| 1 | 1-634662 | 2 | Caster Wheel ASM |
| 1:1 | 1-633582 | 1 | Wheel & Tire ASM |
| 1:1:1 | 1-633002 | 1 | Tire |
| 1:1:2 | 1-633583 | 1 | Wheel |
| 1:1:3 | 1-633584 | 2 | Bearing-Cup |
| 1:2 | 1-633581 | 2 | Spacer-Bearing |
| 1:3 | 1-633580 | 2 | Seal-Bearing |
| 1:4 | 1-633585 | 2 | Bearing-Cone, Taper |
| 1:5 | 1-633579 | 1 | Spacer-Caster, Front |
| 1:6 | 325-36 | 1 | Screw-HH |
| 1:7 | 3296-45 | 1 | Nut-Lock, NI |
| 3 | 1-632511-01 | 2 | Caster |
| 4 | 1-543511 | 2 | Seal-Grease |
| 5 | 254-94 | 4 | Bearing-Cone, Taper |
| 6 | 1-633508 | 6 | Washer-Bellville |
| 7 | 3296-51 | 2 | Nut-Lock, NI |
| 8 | 1-543513 | 2 | Cap-Grease |
| 9 | 322-3 | 6 | Screw-HH |
| 10 | 3256-23 | 4 | Washer-Flat |
| 11 | 99-3940 | 1 | Floorpan-Front |
| 11:2 | 1-633553 | 1 | Pad-Antiskid |
| 11:3 | 1-633737 | 1 | Decal-Z-Master |
| 12 | 1-653049 | 1 | Hinge-Floorpan |
| 13 | 99-3930 | 1 | Footrest ASM |
| 13:2 | 99-3924 | 1 | Decal-Service |
| 13:3 | 98-5954 | 1 | Decal-Missing, Cover |

| Ref. No. | Part No. | Qty. | Description |
|----------|------------|------|-------------------------|
| 13:4 | 1-633553 | 1 | Pad-Antiskid |
| 14 | 3229-10 | 10 | Screw-CARR |
| 15 | 32128-33 | 10 | Nut-HF |
| 16 | 3230-1 | 2 | Screw-CARR |
| 17 | 99-3870-01 | 2 | Bracket-Floorpan |
| 18 | 32128-20 | 8 | Nut-HF |
| 19 | 105-2625 | 1 | Decal-Safety STD |
| 20 | 99-3931 | 1 | Front Frame ASM |
| 20:2 | 1-633818 | 1 | Decal-Warning |
| 21 | 32151-103 | 6 | Ring-Snap |
| 22 | 3256-29 | 6 | Washer-Flat |
| 23 | 3290-357 | 12 | Nut-HHF |
| 24 | 98-5975 | 12 | Washer-Belleville |
| 25 | 323-7 | 12 | Screw-HH |
| 31 | 103-1987 | 2 | Front Spring ASM |
| 31:1 | 1-653011 | 1 | Rod-Lift, Deck |
| 31:2 | 1-633441 | 2 | Swivel-Deck Mount, Rear |
| 31:3 | 3217-11 | 4 | Nut-Hex |
| 31:4 | 3218-6 | 2 | Nut-Jam |
| 31:5 | 1-805517 | 1 | Washer |
| 31:6 | 1-653009 | 1 | Spring-Compression |
| 31:7 | 3256-27 | 1 | Washer-Flat |
| 33 | 99-3871-01 | 1 | LH Lift Arm ASM |
| 34 | 99-3872-01 | 1 | RH Lift Arm ASM |
| 35 | 302-19 | 4 | Fitting-Grease |

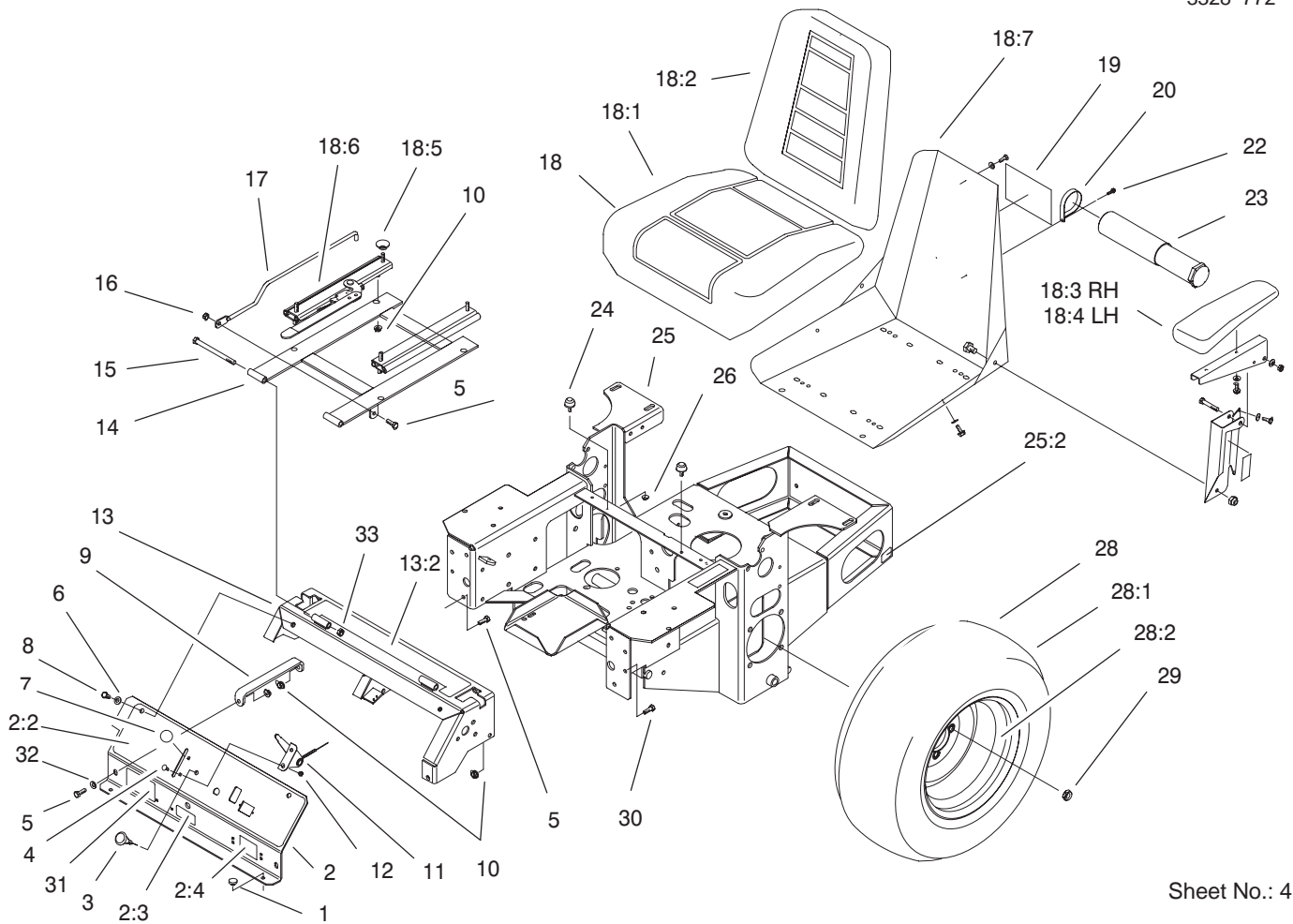

Sheet No.: 4

Main Frame Assembly

| Ref. No. | Part No. | Qty. | Description |
|----------|-------------|------|-----------------------|
| 1 | 1-513658 | 2 | Bumper-Catcher, Grass |
| 2 | 99-3932 | 1 | Control Panel ASM |
| 2:2 | 99-3942 | 1 | Decal-Panel, Control |
| 2:3 | 103-0262 | 1 | Decal-Valve, Fuel |
| 2:4 | 98-4387 | 1 | Decal-Protection, Ear |
| 3 | 1-603336 | 1 | Control-Choke |
| 4 | 1-807513 | 2 | Bolt-CARR |
| 5 | 322-5 | 3 | Screw-HH |
| 6 | 3256-23 | 2 | Washer-Flat |
| 7 | 1-513592 | 1 | Knob-Ball, Red |
| 8 | 322-3 | 3 | Screw-HH |
| 9 | 1-653089-03 | 1 | Bracket |
| 10 | 32128-20 | 12 | Nut-HF |
| 11 | 1-633696 | 1 | Cable-Throttle |
| 12 | 3296-2 | 2 | Nut-Lock |
| 13 | 105-6123 | 1 | Console ASM |
| 13:2 | 103-1997 | 1 | Decal-Top Console |
| 14 | 1-632187-03 | 1 | Frame-Seat |
| 15 | 323-39 | 2 | Screw-HH |
| 16 | 3296-29 | 1 | Nut-Lock, NI |
| 17 | 103-1731 | 1 | Rod-Retainer, Seat |
| 18 | 1-633705 | 1 | Seat W/Tracks |
| 18:1 | 103-0290 | 1 | Cushion-Bottom, Seat |
| 18:2 | 104-7754 | 1 | Cushion-Back, Seat |
| 18:3 | 1-633710 | 1 | Cushion-Armrest, RH |

| Ref. No. | Part No. | Qty. | Description |
|----------|----------|------|---------------------|
| 18:4 | 1-633711 | 1 | Cushion-Armrest, LH |
| 18:5 | 1-543401 | 4 | Spacer-Track |
| 18:6 | 1-643255 | 1 | Grp-Track, Seat |
| 18:7 | 1-633859 | 1 | Frame-Seat |
| 19 | 99-4693 | 1 | Decal-Toro |
| 20 | 2412-120 | 2 | R-Clamp |
| 22 | 32104-76 | 2 | Screw |
| 23 | 74-0720 | 1 | Tube-Manual |
| 24 | 1-523420 | 2 | Bumper |
| 25 | 105-6121 | 1 | Main Frame ASM |
| 25:2 | 65-2690 | 2 | Decal-Surface, Hot |
| 26 | 3296-42 | 2 | Nut-Lock, NI |
| 28 | 1-653159 | 2 | ASM, Wheel & Tire |
| 28:1 | 1-653160 | 1 | Tire |
| 28:2 | 1-653161 | 1 | Wheel |
| 29 | 242-50 | 8 | Nut-Lug |
| 30 | 322-2 | 6 | Screw-HH |
| 31 | 99-8909 | 1 | Decal-Z149 |
| 32 | 3256-3 | 2 | Washer-Flat |
| 33 | 3296-39 | 2 | Nut-Lock, NI |

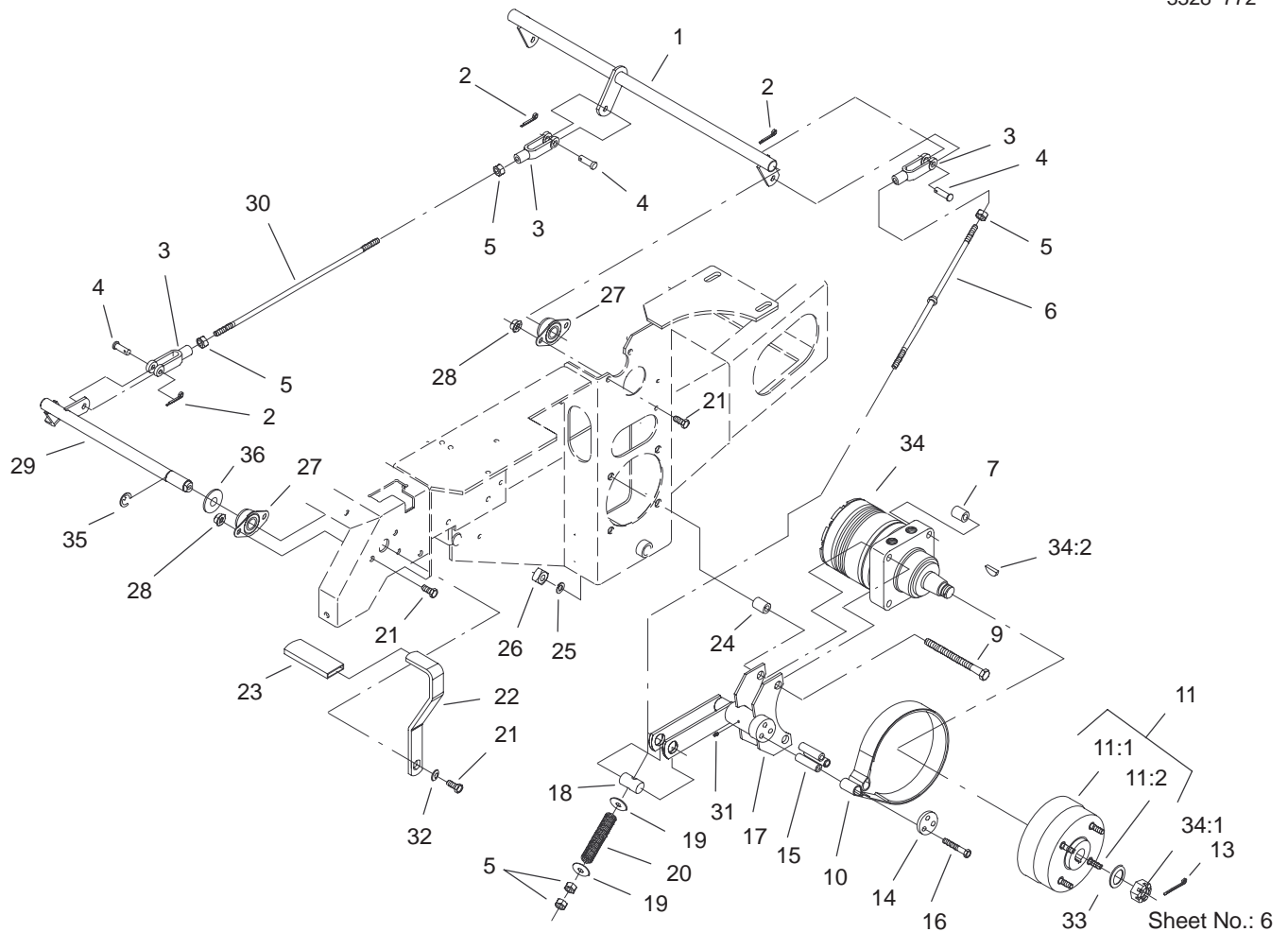

Parking Brake System Assembly

| Ref. No. | Part No. | Qty. | Description | Ref. No. | Part No. | Qty. | Description |
|----------|-------------|------|----------------------|----------|----------|------|-----------------------|
| 1 | 1-652073-03 | 1 | Crank-Brake, Park | 27 | 1-633102 | 4 | Bearing-Flange, Side |
| 2 | 3272-10 | 4 | Pin-Cotter | 28 | 3290-357 | 8 | Nut-HHF |
| 3 | 1-633131 | 4 | Yoke-Linkage, Brake | 29 | 1-652085 | 1 | Shaft-Brake, Parking |
| 4 | 1-808285 | 4 | Pin-Clevis | 30 | 1-653061 | 1 | Linkage-Handle, Brake |
| 5 | 3219-3 | 8 | Nut-HH | 31 | 1481 | 2 | Fitting-Grease |
| 6 | 103-0356 | 2 | Rod-Brake | 32 | 98-5975 | 2 | Washer-Belleville |
| 7 | 1-653068 | 4 | Spacer-Wheel | 33 | 1-523157 | 2 | Washer-Spacer |
| 9 | 325-13 | 8 | Screw-HH | 34 | 1-523328 | 2 | Motor-Wheel |
| 10 | 103-0355 | 2 | Band-Brake | 34:1 | 1-809036 | 1 | Nut-HH |
| 11 | 103-0590 | 2 | Hub-Wheel W/Studs | 34:2 | 3257-42 | 1 | Key-Woodruff |
| 11:1 | 103-0589 | 1 | Hub-Wheel | *34:99 | 1-000099 | 1 | Kit-Seal |
| 11:2 | 1-633926 | 4 | Stud-Wheel | *34:99 | 1-000139 | 1 | Kit-Bearing |
| 13 | 1-806800 | 2 | Pin-Cotter | 35 | 32151-48 | 1 | E-Ring |
| 14 | 103-0374 | 2 | Retainer-Band, Brake | 36 | 3256-28 | 1 | Washer-Flat |
| 15 | 103-0384 | 6 | Spacer | | | | |
| 16 | 322-9 | 6 | Screw-HH | | | | |
| 17 | 103-0352-03 | 2 | Bracket-Brake | | | | |
| 18 | 1-633144 | 2 | Pin-Trunion | | | | |
| 19 | 3256-4 | 4 | Washer-Flat | | | | |
| 20 | 1-633454 | 2 | Spring-Brake | | | | |
| 21 | 323-4 | 9 | Screw-HH | | | | |
| 22 | 1-653074-03 | 1 | Handle-Brake, Park | | | | |
| 23 | 1-633268 | 1 | Grip-Lever, Brake | | | | |
| 24 | 1-653069 | 4 | Spacer-Wheel | | | | |
| 25 | 3253-7 | 8 | Washer-Lock | | | | |
| 26 | 103-0131 | 8 | Nut-Square | | | | |

* Not illustrated

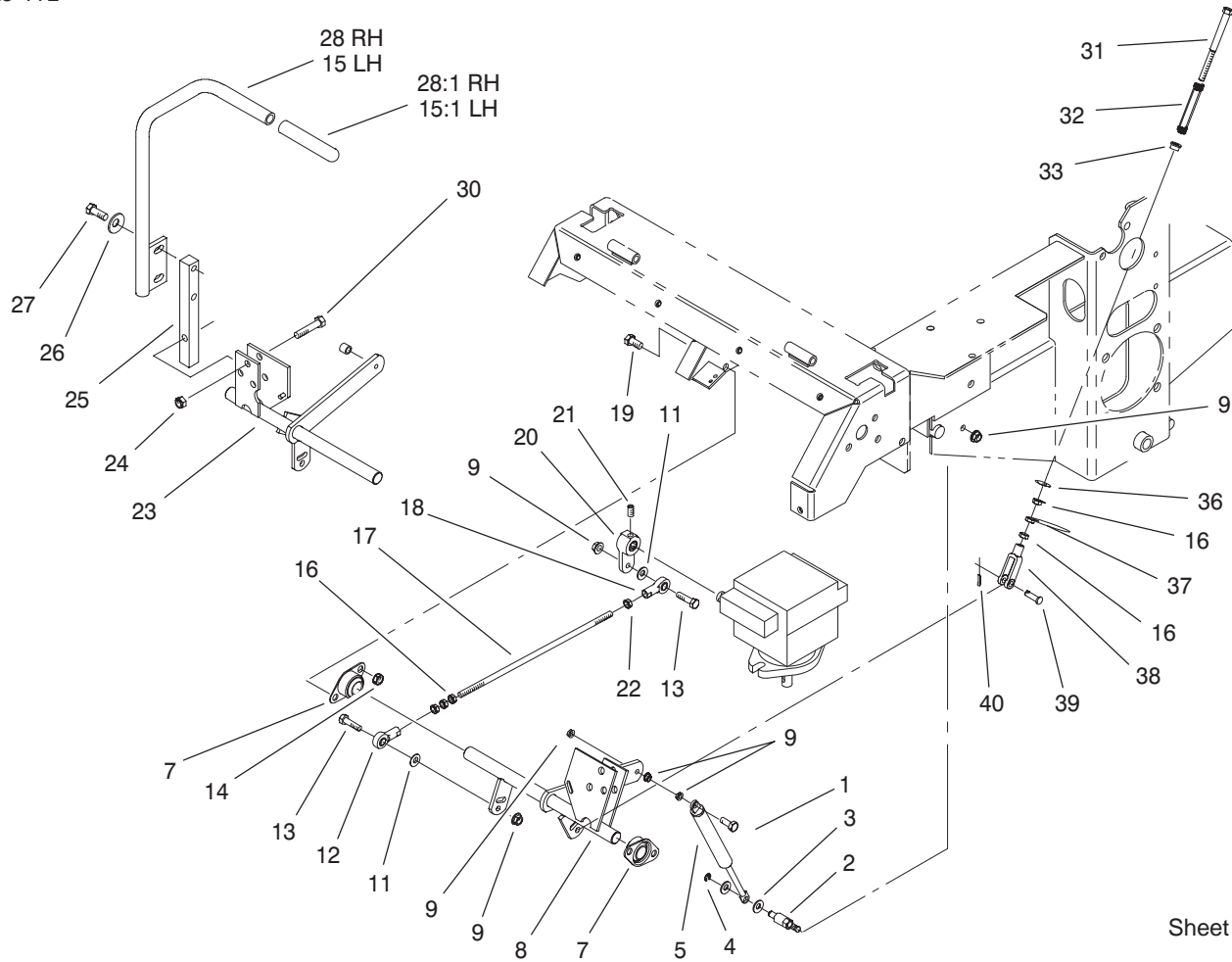

Sheet No.: 7

Motion Control System Assembly

| Ref. No. | Part No. | Qty. | Description |
|----------|----------|------|--------------------------|
| 1 | 1-403180 | 2 | Screw-HH |
| 2 | 1-653316 | 2 | Pin-Damper |
| 3 | 3256-23 | 4 | Washer-Flat |
| 4 | 32120-35 | 2 | E-Ring |
| 5 | 1-523027 | 2 | Damper-Control |
| 7 | 1-633102 | 4 | Bearing-Flange, Side |
| 8 | 103-2199 | 1 | LH Motion Control ASM |
| 9 | 32128-20 | 12 | Nut-HF |
| 11 | 3256-3 | 4 | Washer-Flat |
| 12 | 1-543017 | 2 | Balljoint-RH |
| 13 | 322-6 | 4 | Screw-HH |
| 14 | 3290-357 | 8 | Nut-HHF |
| 15 | 103-0631 | 1 | LH Lever ASM |
| 15:1 | 1-633257 | 1 | Grip-Control, Motion |
| 16 | 3219-2 | 10 | Nut-Hex |
| 17 | 1-653046 | 2 | Linkage-Pump/Lever |
| 18 | 1-633152 | 2 | Balljoint-Thread, LH |
| 19 | 323-4 | 8 | Screw-HH |
| 20 | 1-653092 | 2 | Arm-Control, Pump |
| 21 | 1-803022 | 2 | Screw |
| 22 | 1-804524 | 2 | Nut |
| 23 | 103-2200 | 1 | RH Motion Control ASM |
| 24 | 3296-39 | 6 | Nut-Lock, NI |
| 25 | 103-0407 | 2 | Arm-Shaft, Control |

| Ref. No. | Part No. | Qty. | Description |
|----------|----------|------|---------------------------|
| 26 | 98-5975 | 4 | Washer-Belleville |
| 27 | 323-6 | 4 | Screw-HH |
| 28 | 103-0632 | 1 | RH Lever ASM |
| 28:1 | 1-633257 | 1 | Grip-Control, Motion |
| 30 | 323-9 | 6 | Screw-HH |
| 31 | 1-603737 | 2 | Bolt-Return, Neutral |
| 32 | 1-603807 | 2 | Spring-Return, Neutral |
| 33 | 1-603735 | 2 | Bushing-Flanged |
| 36 | 3256-2 | 2 | Washer-Flat |
| 37 | 3220-2 | 2 | Nut |
| 38 | 1-303105 | 2 | Yoke-Adjustable |
| 39 | 1-808280 | 2 | Pin-Clevis |
| 40 | 3272-5 | 2 | Pin-Cotter |

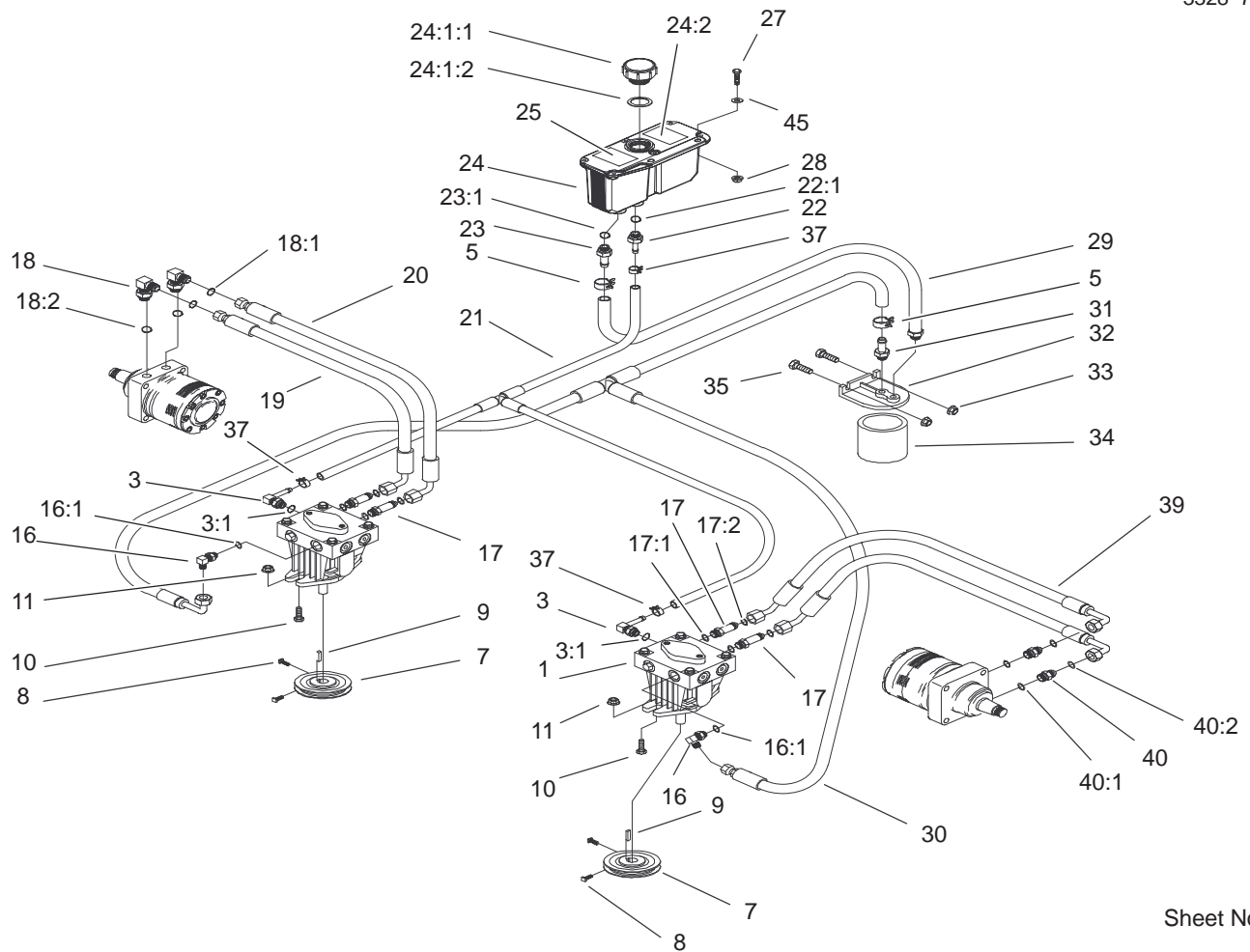

Sheet No.: 8

Hydraulic System Assembly

| Ref. No. | Part No. | Qty. | Description |
|----------|----------|------|-------------------------|
| 1 | 103-1942 | 2 | Pump-Hydraulic |
| *1:1 | 105-6184 | 1 | Kit - Overhaul, Seal |
| *1:2 | 105-6185 | 1 | Plate - Valve |
| *1:8 | 103-2664 | 1 | Kit, Input Shaft 10a |
| *1:9 | 103-2665 | 1 | Kit, Thrust Bearing 10a |
| *1:10 | 103-2666 | 1 | Kit, Cylinder Block 10a |
| 3 | 103-1799 | 2 | Elbow-90° |
| 3:1 | 237-42 | 1 | O-Ring |
| 5 | 103-1988 | 2 | Clamp-Hose |
| 7 | 1-653156 | 2 | Sheave |
| 8 | 1-803050 | 4 | Screw-Set |
| 9 | 1-807272 | 2 | Key-Machine |
| 10 | 323-7 | 4 | Screw-HH |
| 11 | 3290-357 | 4 | Nut-HHF |
| 16 | 103-1802 | 2 | Elbow-90° |
| 16:1 | 237-42 | 1 | O-Ring |
| 17 | 103-1940 | 4 | Adapter, Straight |
| 17:1 | 237-79 | 1 | O-Ring |
| 17:2 | 1-603992 | 1 | O-Ring |
| 18 | 1-633605 | 2 | Fitting-Connector |
| 18:1 | 1-603992 | 1 | O-Ring |
| 18:2 | 237-80 | 1 | O-Ring |
| 19 | 1-653186 | 1 | Hose, Front |
| 20 | 1-653187 | 1 | Hose, RH Rear |
| 21 | 103-1800 | 1 | HYD Hose ASM |
| 22 | 103-1801 | 1 | Adapter-Straight |

| Ref. No. | Part No. | Qty. | Description |
|----------|----------|------|-------------------------|
| 22:1 | 237-42 | 1 | O-Ring |
| 23 | 103-1912 | 1 | Adapter, Straight |
| 23:1 | 237-42 | 1 | O-Ring |
| 24 | 103-1947 | 1 | HYD Reservoir ASM |
| ☆24:1 | 103-1948 | 1 | HYD Reservoir ASM |
| 24:1:1 | 103-1948 | 1 | Cap-Hydraulic Reservoir |
| 24:1:2 | 103-1949 | 1 | Gasket-Cap |
| 24:2 | 1-523552 | 1 | Decal-Tank, Hydraulic |
| 25 | 103-2644 | 1 | Decal-Exhaust |
| 27 | 321-14 | 2 | Screw-HH |
| 28 | 32128-33 | 2 | Nut-HF |
| 29 | 103-1805 | 1 | HYD Hose ASM |
| 30 | 103-1803 | 1 | HYD Hose ASM |
| 31 | 103-1804 | 1 | Adapter-Straight |
| 32 | 1-603720 | 1 | Head-Filter |
| 33 | 32128-20 | 2 | Nut-HF |
| 34 | 1-633750 | 1 | Filter-HYD |
| 34 | 1-633752 | 1 | Filter-HYD, Winter |
| 35 | 322-5 | 2 | Screw-HH |
| 37 | 103-1716 | 3 | Clamp-Hose |
| 39 | 103-1680 | 2 | Hose-LH |
| 40 | 1-603991 | 2 | Fitting-Straight |
| 40:1 | 237-80 | 1 | O-Ring |
| 40:2 | 1-603992 | 1 | O-Ring |
| 45 | 3256-22 | 2 | Washer-Flat |

* Not illustrated

☆ Not serviced separately

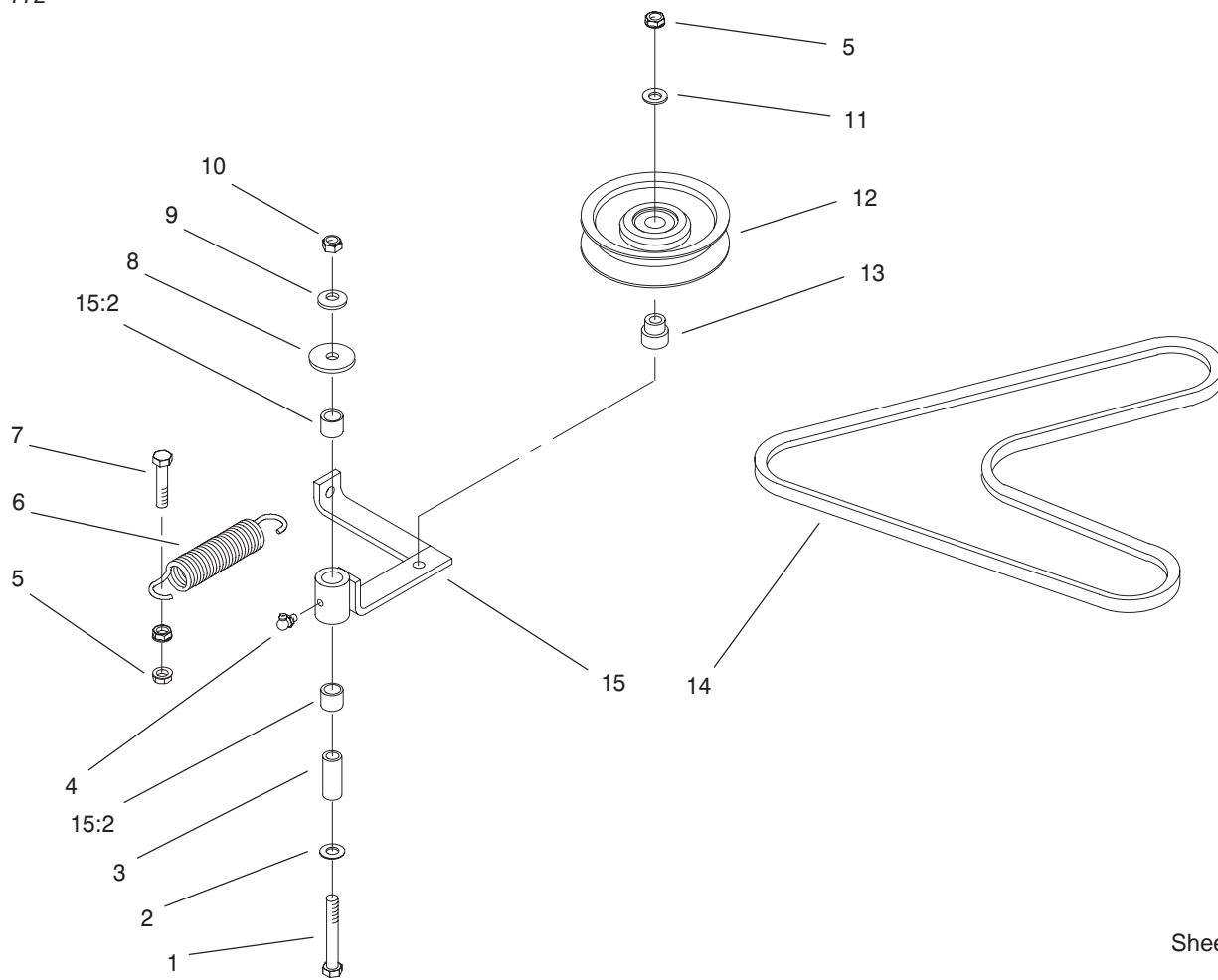

Sheet No.: 9

Pump, Idler and Belt Assembly

| Ref. No. | Part No. | Qty. | Description |
|----------|----------|------|-------------------|
| 1 | 323-13 | 1 | Screw-HH |
| 2 | 3256-4 | 1 | Washer-Flat |
| 3 | 1-603044 | 1 | Bushing |
| 4 | 302-40 | 1 | Fitting-Grease |
| 5 | 3290-357 | 3 | Nut-HHF |
| 6 | 103-1767 | 1 | Spring-Extension |
| 7 | 323-9 | 2 | Screw-HH |
| 8 | 1-373034 | 1 | Washer-Swivel |
| 9 | 98-5975 | 1 | Washer-Belleville |
| 10 | 3296-39 | 1 | Nut-Lock, NI |
| 11 | 3256-24 | 1 | Washer-Flat |
| 12 | 1-603843 | 1 | Pulley-Idler |
| 13 | 1-603496 | 1 | Bushing-Idler |
| 14 | 1-653283 | 1 | Belt-Pump |
| 15 | 1-654143 | 1 | Idler Arm |
| 15:2 | 1-513034 | 2 | Sleeve-Bearing |

| Ref. No. | Part No. | Qty. | Description |
|----------|----------|------|-------------|
| | | | |
| | | | |
| | | | |
| | | | |
| | | | |
| | | | |
| | | | |
| | | | |
| | | | |
| | | | |

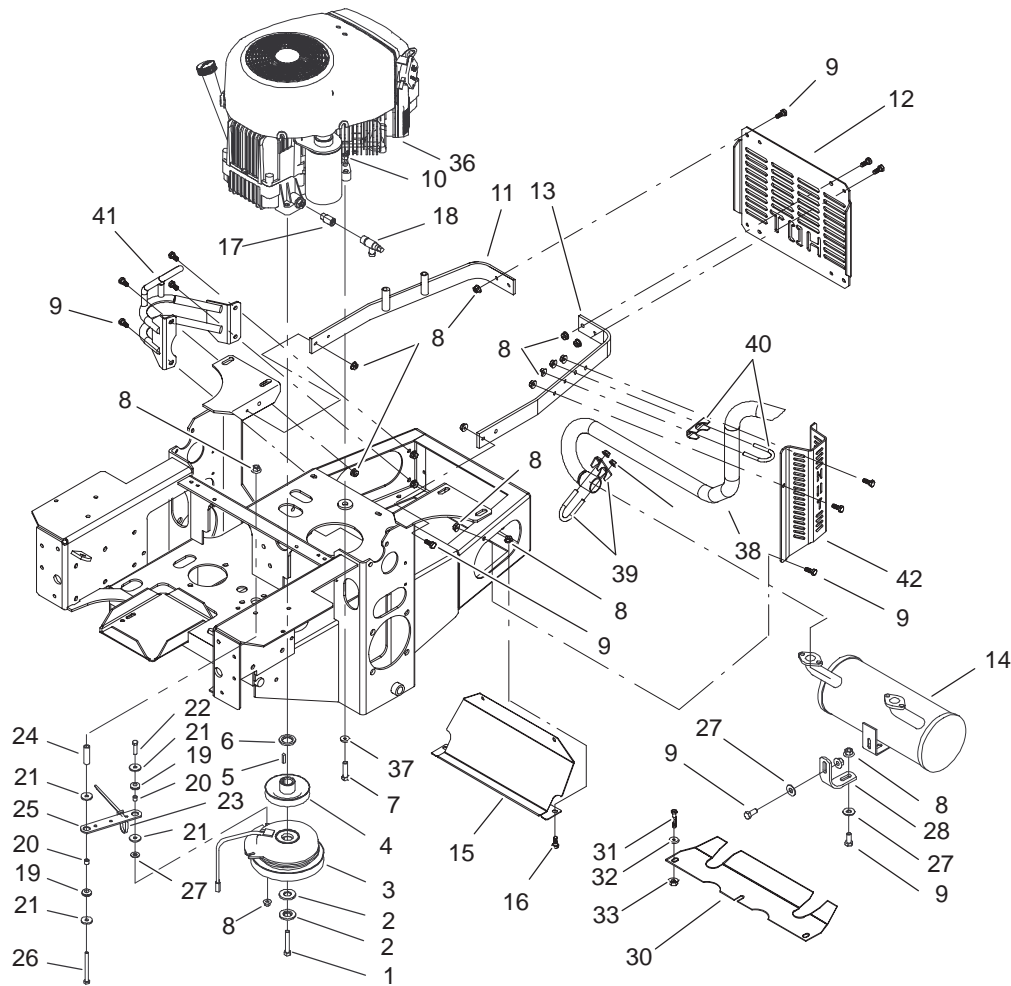

Sheet No.: 10

Engine and Clutch Assembly

| Ref. No. | Part No. | Qty. | Description |
|----------|-------------|------|-----------------------------|
| 1 | 3212-12 | 1 | Screw-HH |
| 2 | 1-603610 | 2 | Washer-Spring |
| 3 | 1-653048 | 1 | Clutch-Stop |
| 4 | 1-653035 | 1 | Sheave W/Hub |
| 5 | 1-807259 | 1 | Key |
| 6 | 103-2308 | 1 | Spacer-Crankshaft |
| 7 | 322-9 | 4 | Screw-HH |
| 8 | 32128-20 | 27 | Nut-HF |
| 9 | 322-3 | 21 | Screw-HH |
| 10 | 3296-29 | 4 | Nut-Lock, NI |
| 11 | 1-652146-03 | 1 | Strap-Guard, Engine |
| 12 | 1-653095-03 | 1 | Shield-Engine |
| 13 | 103-2751-03 | 1 | Strap, Eng Guard LH Exhaust |
| 14 | 103-1322 | 1 | Muffler |
| 15 | 103-2560-03 | 1 | Shield-Heat |
| 16 | 322-2 | 4 | Screw-HH |
| 17 | 103-1966 | 1 | Adapter |
| 18 | 103-1965 | 1 | Valve-Drain, Oil |
| 19 | 1-633630 | 2 | Grommet-Brake |
| 20 | 1-633545 | 2 | Spacer-Grommet |
| 21 | 1-613235 | 4 | Washer |
| 22 | 322-6 | 1 | Screw-HH |
| 23 | 1-303335 | 2 | Tie-Plastic |
| 24 | 1-523406 | 1 | Bushing-Mount, Seat |
| 25 | 1-633543-03 | 1 | Strap-Clutch, Brake |

| Ref. No. | Part No. | Qty. | Description |
|----------|-------------|------|------------------------------|
| 26 | 322-22 | 1 | Screw-HH |
| 27 | 3256-3 | 3 | Washer-Flat |
| 28 | 1-653196 | 1 | Bracket-Support, Muffler |
| 30 | 1-653539-03 | 1 | Shield,Heat |
| 31 | 3230-1 | 3 | Screw-CARR |
| 32 | 3256-23 | 3 | Washer-Flat |
| 33 | 3296-29 | 3 | Nut-Lock, NI |
| ☆36 | | 1 | Engine-Kawasaki, FH601V-AS23 |
| 37 | 1-303334 | 2 | Washer-Spring |
| 38 | 103-2599 | 1 | Wld, Tailpipe |
| 39 | 103-2630 | 1 | Clamp, 1.25" |
| 40 | 103-2631 | 1 | Clamp, 1.125" |
| 41 | 103-2564-03 | 1 | RH Exhaust Guard ASM |
| 42 | 103-2566-03 | 1 | LH Exhaust Guard ASM |

☆ Not serviced separately

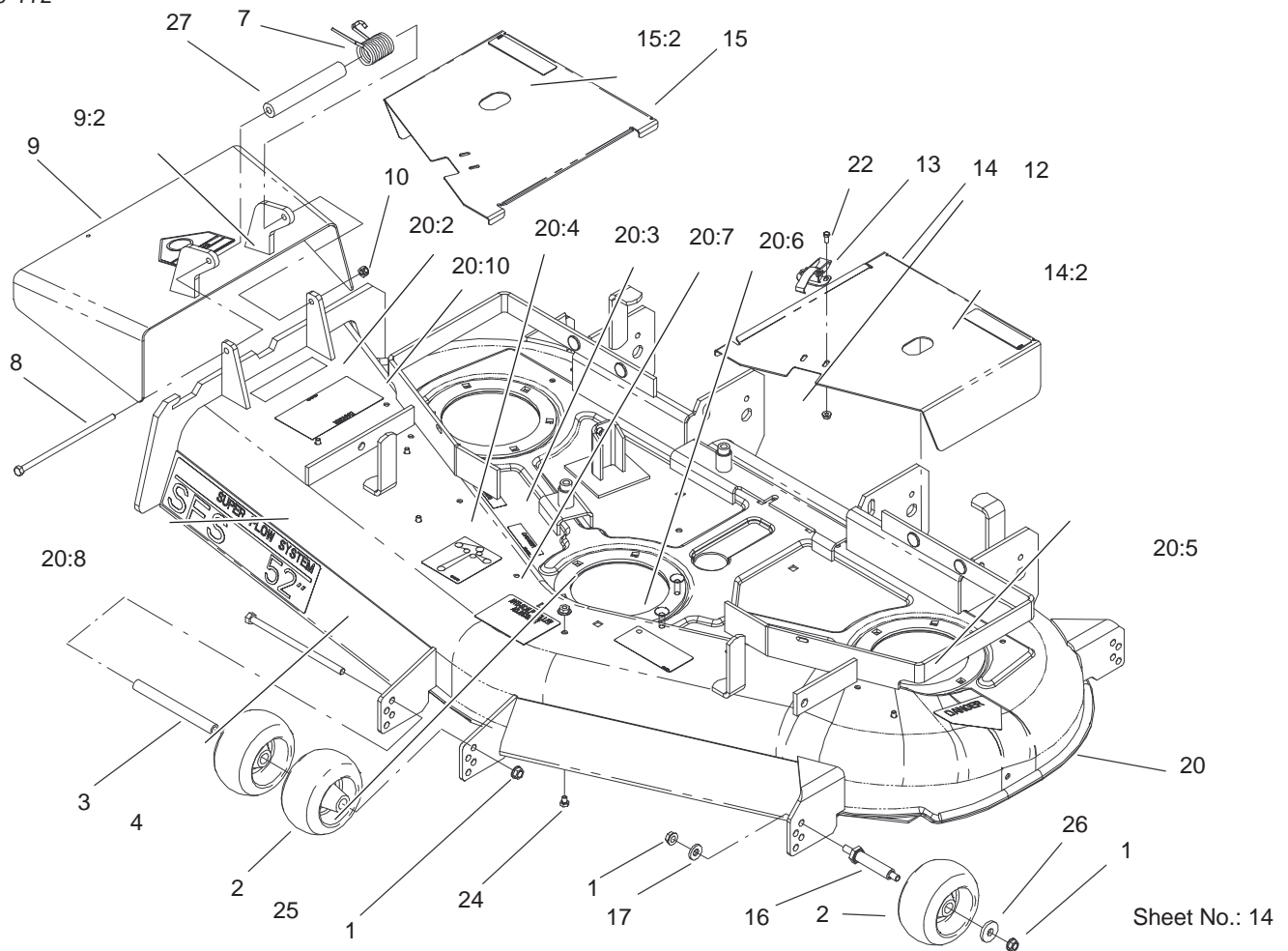

Sheet No.: 14

Deck Assembly

| Ref. No. | Part No. | Qty. | Description |
|----------|----------|------|--------------------------------------|
| 1 | 3290-357 | 9 | Nut-HHF |
| 2 | 68-2730 | 6 | Wheel-Gage |
| 3 | 98-5967 | 1 | Spacer-Wheel |
| 4 | 323-28 | 1 | Screw-HH |
| 7 | 104-8554 | 1 | Spring-Torsion |
| 8 | 322-50 | 1 | Screw-Cap |
| 9 | 105-4623 | 1 | Deflector ASM |
| 9:2 | 54-9220 | 1 | Decal-Danger |
| 10 | 3296-29 | 1 | Nut-Lock, NI |
| 12 | 32128-17 | 4 | Nut-Lock, Flange |
| 13 | 249-21 | 2 | Clamp-Slotted |
| 14 | 99-3896 | 1 | LH Cover ASM |
| 14:2 | 67-5360 | 1 | Decal-Danger |
| 15 | 99-3895 | 1 | RH Cover ASM |
| 15:2 | 67-5360 | 1 | Decal-Danger |
| 16 | 99-2842 | 4 | Spacer-Wheel |
| 17 | 98-5975 | 4 | Washer-Belleville |
| 20 | 105-1695 | 1 | Deck Service ASM (52, 100 Series) |
| ☆20 | | 1 | Deck ASM W/ Decals |
| 20:2 | 104-8569 | 1 | Decal-Warning, Deflector |
| 20:3 | 98-5954 | 3 | Decal-Missing, Cover |
| 20:4 | 99-3943 | 1 | Decal-Routing, Belt |
| 20:5 | 43-8480 | 1 | Decal-Danger |

| Ref. No. | Part No. | Qty. | Description |
|----------|----------|------|---------------------------------|
| 20:6 | 93-7818 | 1 | Decal-Torque, Blade Bolt |
| 20:7 | 98-3798 | 1 | Decal-Wheel, Gage |
| 20:8 | 98-5953 | 1 | Decal-Sfs |
| 20:10 | 66-1340 | 1 | Decal-Danger |
| 22 | 3290-321 | 4 | Screw-HWH |
| 24 | 321-1 | 6 | Screw-HH |
| 25 | 32128-33 | 6 | Nut-HF |
| 26 | 1-373034 | 4 | Washer-Swivel |
| 27 | 105-4622 | 1 | Spacer - Mounting, Deflector |

☆ Not serviced separately

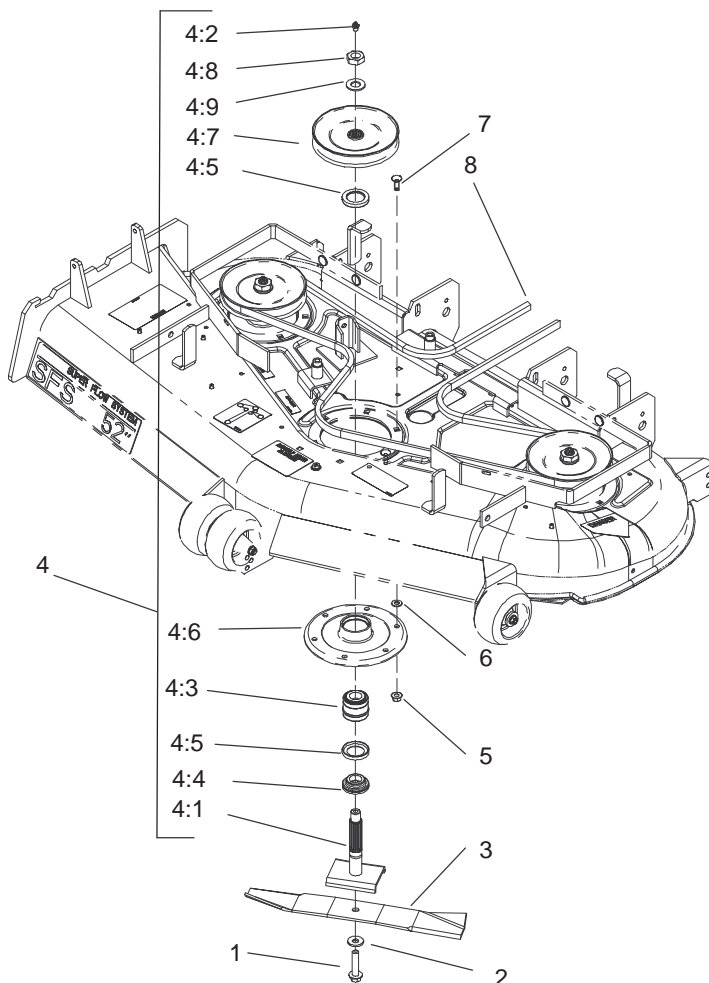

Sheet No.: 15

Deck Spindle Assembly

| Ref. No. | Part No. | Qty. | Description |
|----------|----------|------|-------------------------|
| 1 | 92-5816 | 3 | Bolt-Blade |
| 2 | 1-513435 | 3 | Washer-Spring |
| 3 | 56-2390 | 3 | Blade |
| 4 | 100-3976 | 3 | Spindle Housing ASM |
| 4:1 | 100-3972 | 1 | Spindle Shaft ASM |
| 4:2 | 302-2 | 1 | Fitting-Grease |
| 4:3 | 46-8530 | 1 | Bearing ASM |
| 4:4 | 27-0950 | 1 | Spacer-Bearing, Spindle |
| 4:5 | 253-139 | 2 | Seal-Oil |
| 4:6 | 61-4160 | 1 | Housing-Spindle |
| 4:7 | 100-3970 | 1 | Pulley And Hub ASM |
| 4:8 | 32146-20 | 1 | Nut-Jam |
| 4:9 | 7-4150 | 1 | Washer-Pinion |
| 5 | 32128-21 | 18 | Nut-HF |
| 6 | 3256-24 | 6 | Washer-Flat |
| 7 | 3231-22 | 18 | Screw-CARR |
| 8 | 99-3904 | 1 | Belt-Deck |

| Ref. No. | Part No. | Qty. | Description |
|----------|----------|------|-------------|
| | | | |
| | | | |
| | | | |
| | | | |
| | | | |
| | | | |
| | | | |
| | | | |
| | | | |
| | | | |
| | | | |
| | | | |
| | | | |
| | | | |
| | | | |
| | | | |
| | | | |
| | | | |
| | | | |
| | | | |
| | | | |
| | | | |
| | | | |
| | | | |

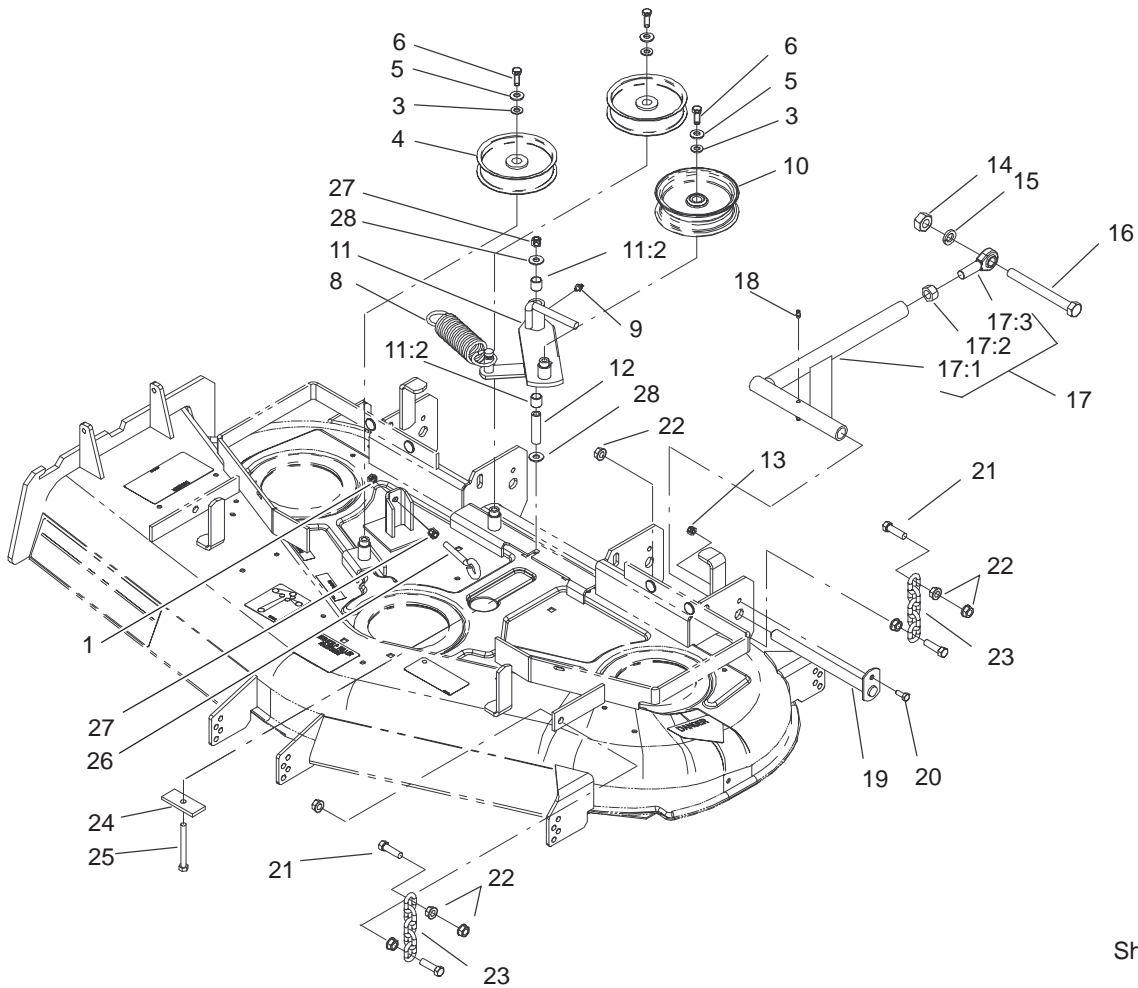

Sheet No.: 16

Idler, Pulley/Lift Strut, Chain Assembly

| Ref. No. | Part No. | Qty. | Description |
|----------|-------------|------|----------------------|
| 1 | 3217-7 | 1 | Nut-Hex |
| 3 | 3256-24 | 3 | Washer-Flat |
| 4 | 1-613098 | 2 | Pulley-Idler |
| 5 | 98-5975 | 3 | Washer-Belleville |
| 6 | 323-6 | 3 | Screw-HH |
| 8 | 1-633151 | 1 | Spring-Extension |
| 9 | 302-40 | 1 | Fitting-Grease |
| 10 | 1-413099 | 1 | Pulley-Idler |
| 11 | 99-3879 | 1 | Idler Arm ASM |
| 11:2 | 1-513034 | 2 | Sleeve-Bearing |
| 12 | 1-603384 | 1 | Bushing-Pivot, Idler |
| 13 | 3296-29 | 2 | Nut-Lock, NI |
| 14 | 3217-11 | 2 | Nut-Hex |
| 15 | 3253-8 | 2 | Washer-Lock |
| 16 | 1-800344 | 2 | Screw |
| 17 | 103-1081 | 2 | Strut ASM |
| 17:1 | 103-1072-01 | 1 | Strut-Deck |
| 17:2 | 3219-6 | 1 | Nut-Hex |
| 17:3 | 1-633029 | 1 | Balljoint-Spherical |
| 18 | 302-19 | 4 | Fitting-Grease |
| 19 | 1-632199-01 | 2 | Pin-Strut, Deck |
| 20 | 322-3 | 2 | Screw-HH |
| 21 | 1-800811 | 8 | Screw-Cap, HH |
| 22 | 32128-37 | 16 | Nut-HF |
| 23 | 1-633447 | 4 | Chain-Lift, Deck |
| 24 | 99-3946-01 | 1 | Plate-Retainer, Bolt |

| Ref. No. | Part No. | Qty. | Description |
|----------|----------|------|-----------------|
| 25 | 1-800805 | 1 | Screw-HH |
| 26 | 94-2547 | 1 | Bolt-Eye |
| 27 | 3296-39 | 2 | Nut-Lock, NI |
| 28 | 1-809107 | 2 | Washer-Hardened |

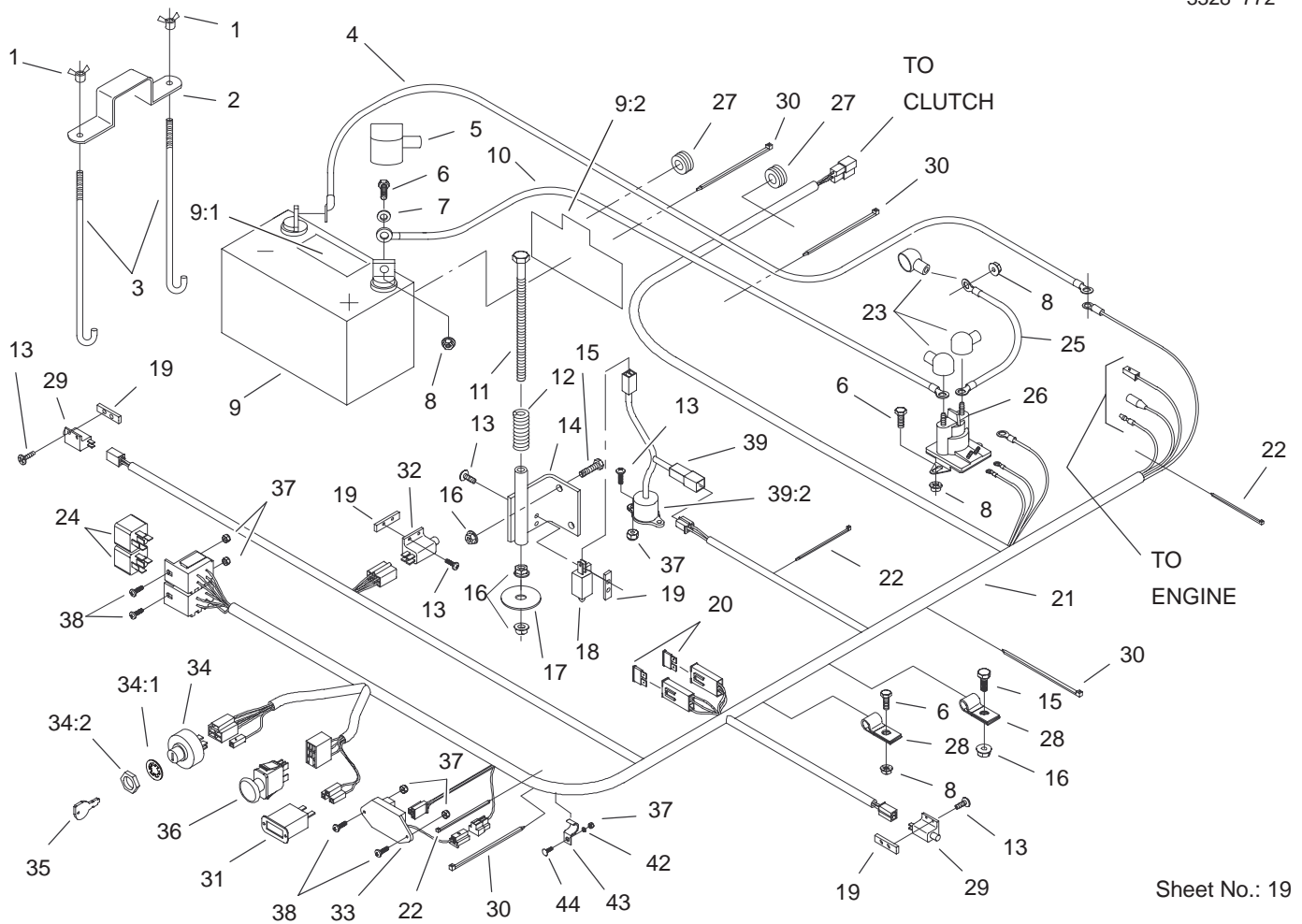

Sheet No.: 19

Electrical System Assembly

| Ref. No. | Part No. | Qty. | Description |
|----------|-------------|------|-------------------------|
| 1 | 1-543792 | 2 | Wingnut |
| 2 | 1-633652-03 | 1 | Strap-Holddown, Battery |
| 3 | 1-633651 | 2 | Bolt-Holddown |
| 4 | 103-0705 | 1 | Cable-Ground, Negative |
| 5 | 1-543391 | 1 | Insulator-Battery |
| 6 | 321-4 | 5 | Screw-HH |
| 7 | 3256-2 | 2 | Washer-Flat |
| 8 | 32128-33 | 6 | Nut-HF |
| 9 | 105-1692 | 1 | Battery - 230 Cca |
| 9:1 | 104-4163 | 1 | Decal-Battery |
| 9:2 | 104-4164 | 1 | Decal-Battery |
| 10 | 103-0707 | 1 | Cable-Battery, Pos. |
| 11 | 1-800282 | 1 | Screw-HH |
| 12 | 1-523415 | 1 | Spring-Switch, Seat |
| 13 | 3290-500 | 10 | Screw-PPH |
| 14 | 1-652072-03 | 1 | Bracket-Switch, Seat |
| 15 | 322-3 | 3 | Screw-HH |
| 16 | 32128-20 | 5 | Nut-HF |
| 17 | 1-653036 | 1 | Washer |
| 18 | 1-513152 | 1 | Switch-Closed, Normally |
| 19 | 1-633181 | 4 | Plate-Tapped |
| 20 | 1-816001 | 2 | Fuse-Type, Blade |
| 21 | 103-0623 | 1 | Harness-Wire |

| Ref. No. | Part No. | Qty. | Description |
|----------|----------|------|-----------------------|
| 22 | 1-303287 | 3 | Tie-Plastic |
| 23 | 1-543393 | 3 | Insulator-Solenoid |
| 24 | 1-643275 | 2 | Relay |
| 25 | 1-633306 | 1 | Wire-Starter |
| 26 | 1-513075 | 1 | Switch-Solenoid |
| 27 | 1-543286 | 2 | Grommet |
| 28 | 1-633396 | 2 | Clip-Loom |
| 29 | 1-513051 | 2 | Switch-Open, Normally |
| 30 | 1-303335 | 4 | Tie-Plastic |
| 31 | 1-513374 | 1 | Meter-Hour |
| 32 | 1-633111 | 1 | Switch |
| 33 | 100-6186 | 1 | Module-Delay, Seat |
| 34 | 88-9830 | 1 | Key Switch ASM |
| 34:1 | 3254-5 | 1 | Washer-Lock, Internal |
| 34:2 | 218-461 | 1 | Nut-HH |
| 35 | 63-8360 | 2 | Key-Ignition |
| 36 | 1-633673 | 1 | Switch-Delta |
| 37 | 3296-2 | 7 | Nut-Lock |
| 38 | 1-807513 | 4 | Bolt-CARR |
| 39 | 1-644427 | 1 | Tilt Switch ASM |
| 39:2 | 1-643401 | 1 | Decal-Switch, Mercury |
| 42 | 3256-14 | 1 | Washer-Flat |
| 43 | 103-1193 | 1 | Clip-Half, Loom |
| 44 | 1-807533 | 1 | Bolt-CARR |

Electrical Schematic

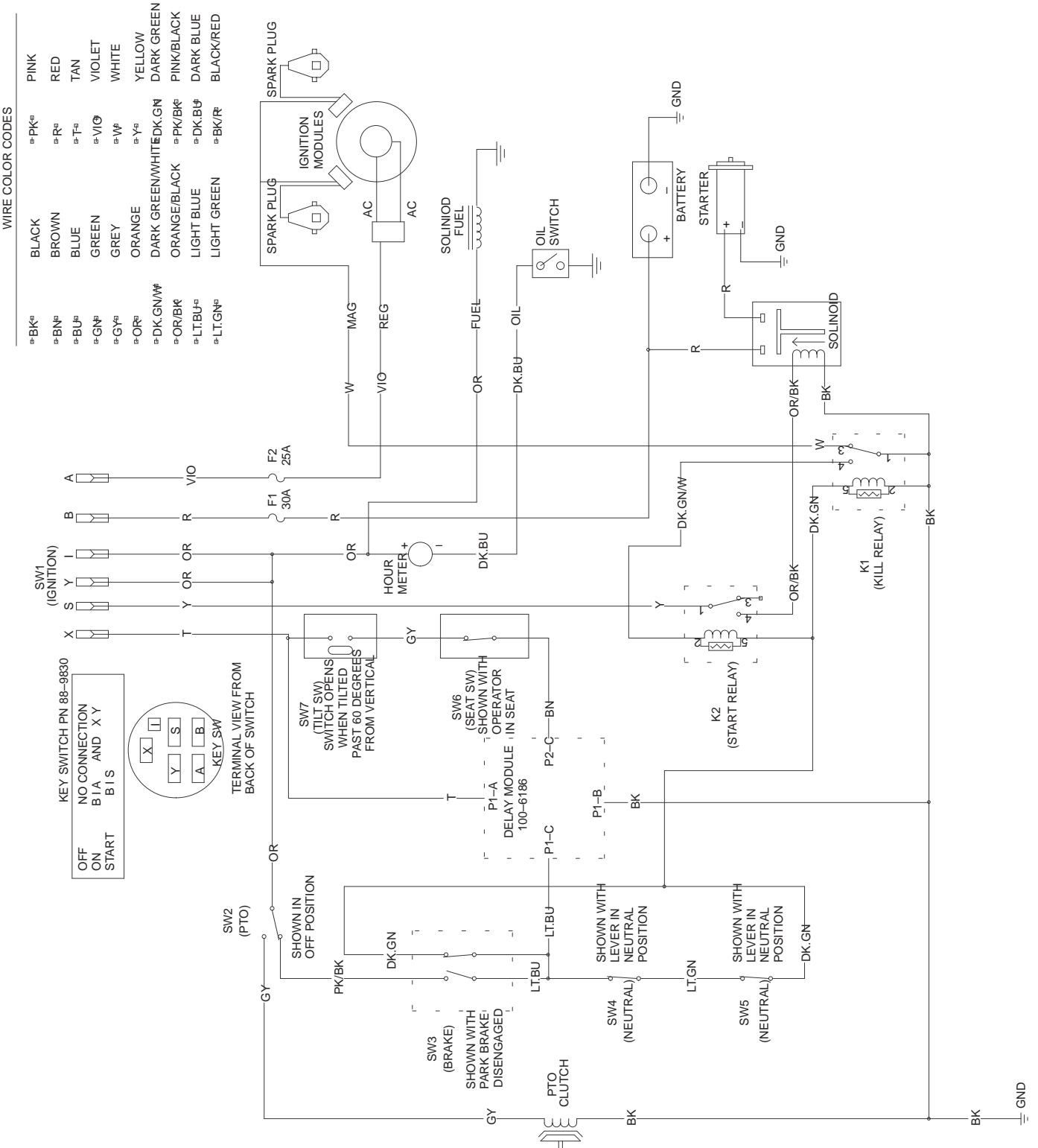

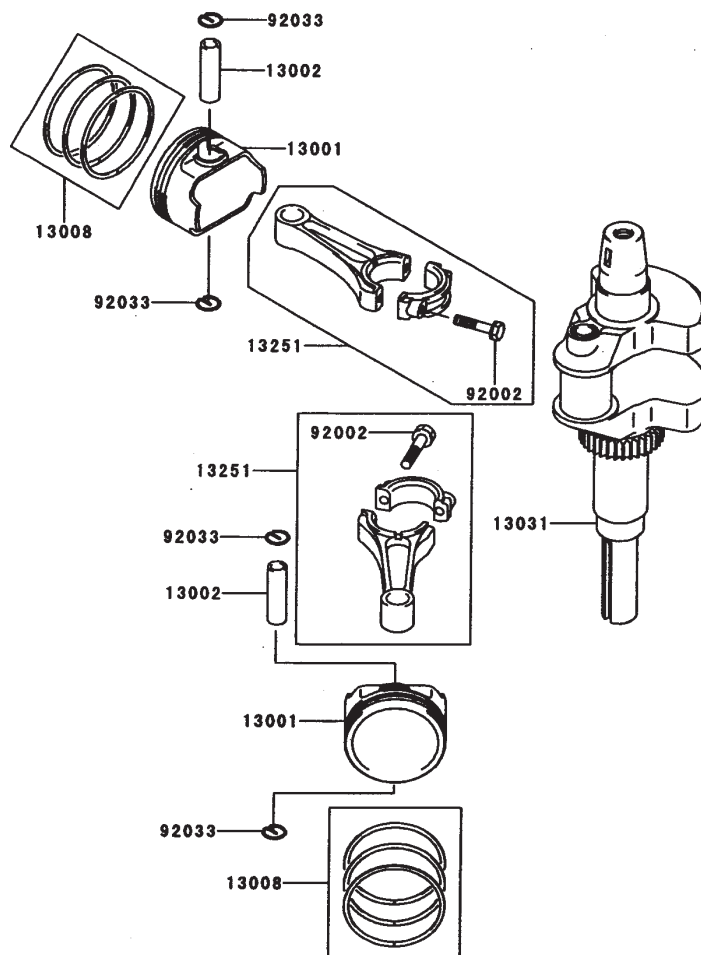

Piston/Crankshaft Assembly – Kawasaki FH601V–AS23

| Ref. No. | Part No. | Qty. | Description | Ref. No. | Part No. | Qty. | Description |
|----------|------------|------|---------------------|----------|----------|------|-------------|
| 13001 | 13001-7006 | 2 | Piston-Engine | | | | |
| 13002 | 13002-7001 | 2 | Pin-Piston | | | | |
| 13008 | 13008-6058 | 2 | Ring-Set-Piston | | | | |
| 13031 | 13031-7002 | 1 | Crankshaft-Comp | | | | |
| 13251 | 13251-7002 | 2 | Rod-Assy-Connecting | | | | |
| 92002 | 92002-2053 | 4 | Bolt | | | | |
| 92033 | 92033-7005 | 4 | Ring-Snap | | | | |

Cylinder/Crankcase Assembly – Kawasaki FH601V-AS23

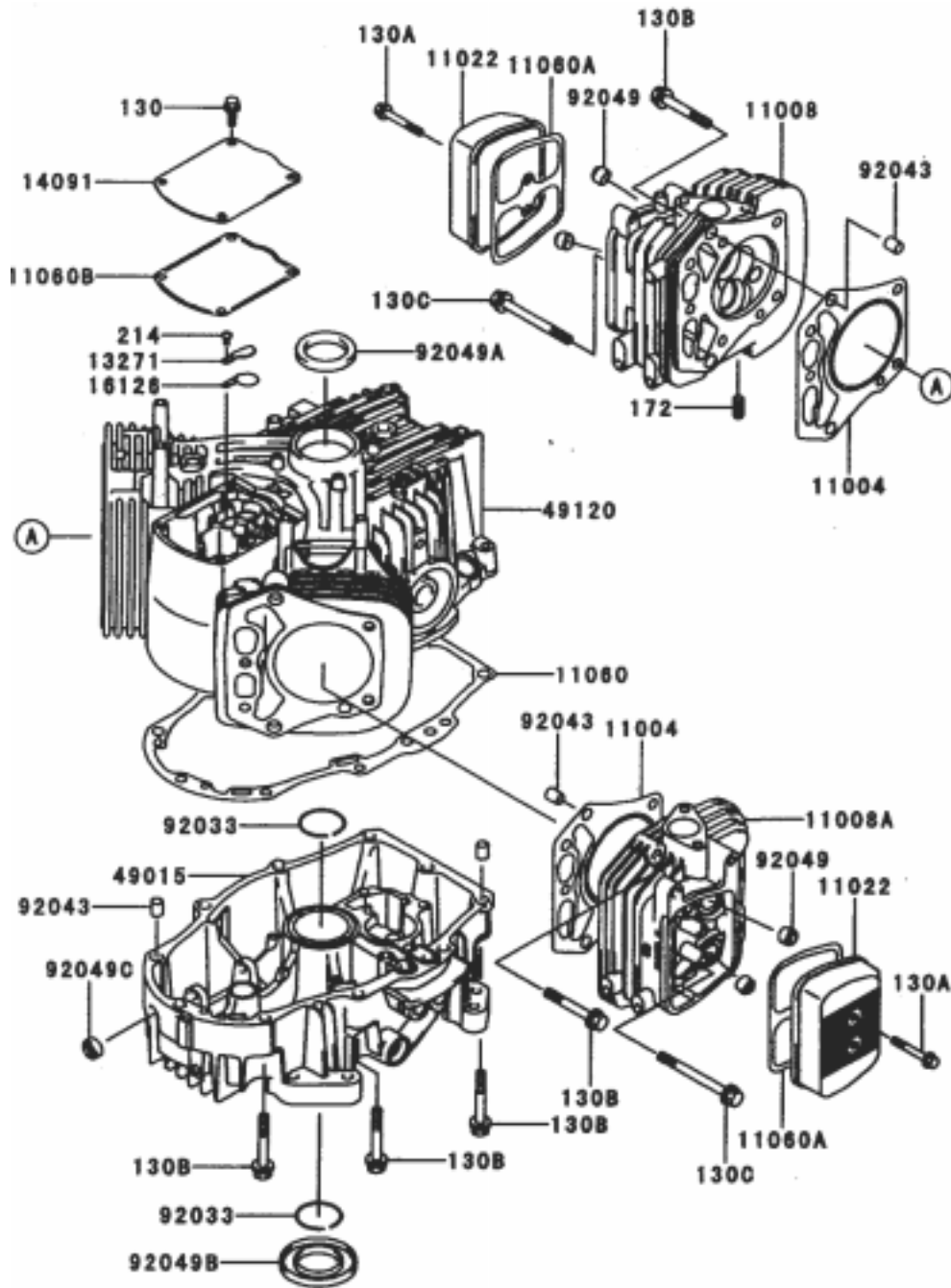

Cylinder/Crankcase Assembly – Kawasaki FH601V–AS23

| Ref. No. | Part No. | Qty. | Description |
|----------|------------|------|-----------------------------|
| 11004 | 11004-7004 | 2 | Gasket-Head |
| 11008 | 11008-7003 | 1 | Head-Comp-Cylinder No. 1 |
| 11008A | 11008-7004 | 1 | Head-Comp-Cylinder No. 2 |
| 11022 | 11022-7002 | 2 | Case-Rocker |
| 11060 | 11060-7012 | 1 | Gasket, CrankCase Cover |
| 11060A | 11060-7013 | 2 | Gasket, Rocker Case |
| 11060B | 11060-7014 | 1 | Gasket, Breather |
| 13271 | 13271-7006 | 1 | Plate |
| 14090 | 14091-7004 | 1 | Cover |
| 16126 | 16126-7001 | 1 | Valve |
| 49015 | 49015-6220 | 1 | Cover-Crankcase |
| 49120 | 49120-6122 | 1 | Crankcase-Comp |
| 92033 | 92033-7004 | 2 | Ring-Snap |
| 92043 | 92043-7001 | 6 | Pin |
| 92049 | 92049-7001 | 4 | Seal-Oil |
| 92049A | 92049-7002 | 1 | Seal-Oil |
| 92049B | 92049-7004 | 1 | Seal-Oil |
| 92049C | 92049-7005 | 1 | Seal-Oil |
| 130 | 130B0612 | 4 | Bolt-Flanged |
| 130A | 130B0640 | 4 | Bolt-Flanged |
| 130B | 130T0850 | 18 | Bolt-Flanged |
| 130C | 130T0875 | 2 | Bolt-Flanged |
| 172 | 172G0818 | 4 | Bolt-Stud |
| 214 | 214B0408 | 1 | Screw-Pan |

| Ref. No. | Part No. | Qty. | Description |
|----------|----------|------|-------------|
| | | | |

Valve/Camshaft Assembly – Kawasaki FH601V-AS23

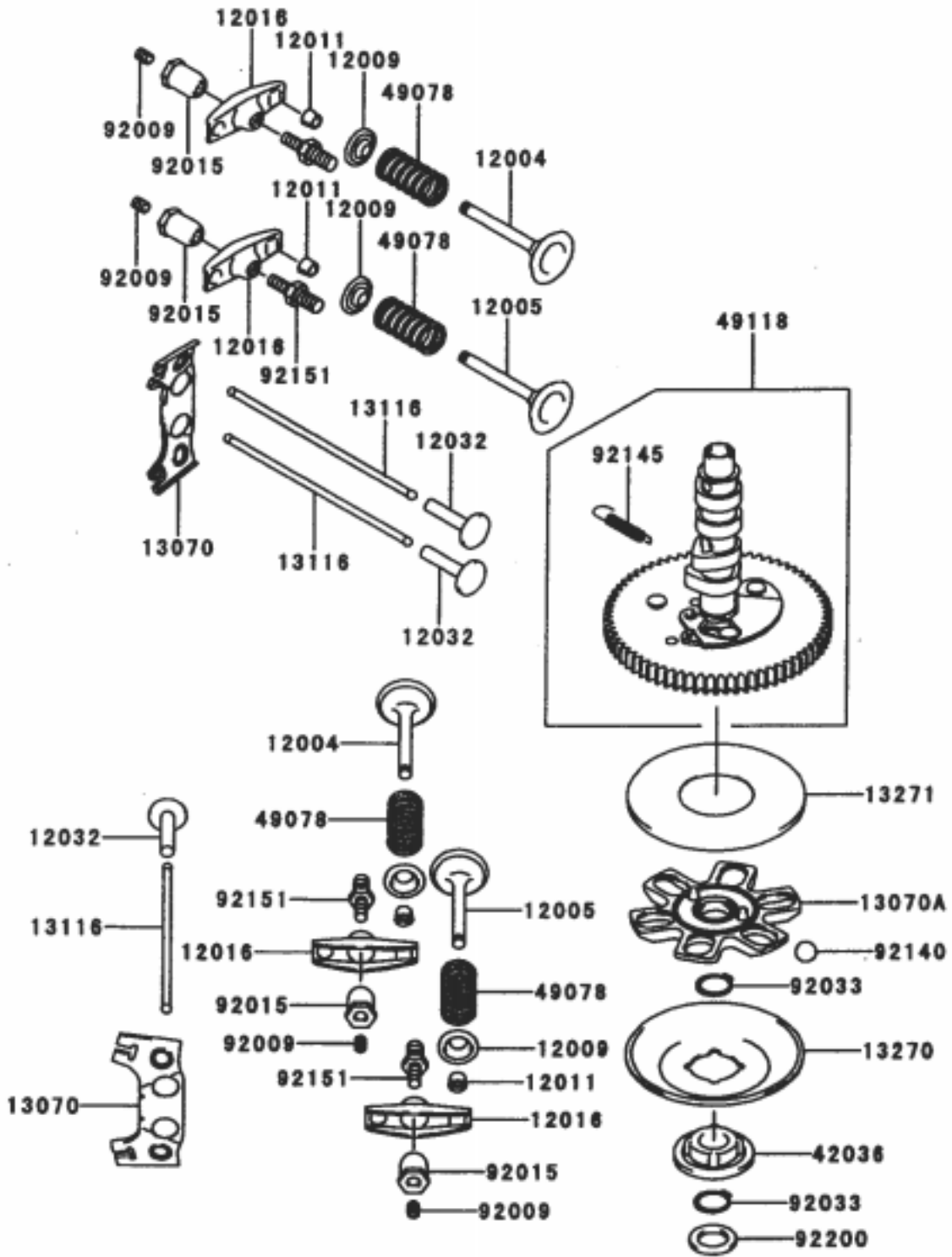

Valve/Camshaft Assembly – Kawasaki FH601V–AS23

| Ref. No. | Part No. | Qty. | Description |
|----------|------------|------|-----------------------|
| 12004 | 12004-7002 | 2 | Valve-Intake |
| 12005 | 12005-7002 | 2 | Valve-Exhaust |
| 12009 | 12009-7001 | 4 | Retainer-Valve Spring |
| 12011 | 12011-2056 | 8 | Collet |
| 12016 | 12016-7002 | 4 | Arm-Rocker |
| 12032 | 12032-7001 | 4 | Tappet |
| 13070 | 13070-7003 | 2 | Guide |
| 13070A | 13070-7004 | 1 | Guide |
| 13116 | 13116-7001 | 4 | Rod-Push |
| 13270 | 13270-7002 | 1 | Plate |
| 13271 | 13271-7007 | 1 | Plate |
| 42036 | 42036-7001 | 1 | Sleeve |
| 49078 | 49078-7002 | 4 | Spring-Engine Valve |
| 49118 | 49118-7003 | 1 | Camshaft-Comp |
| 92009 | 92009-2341 | 4 | Screw |
| 92015 | 92015-2253 | 4 | Nut |
| 92033 | 92033-7001 | 2 | Ring-Snap |
| 92140 | 92140-7002 | 6 | Ball |
| 92145 | 92145-7001 | 1 | Spring |
| 92151 | 92151-7001 | 4 | Bolt |
| 92200 | 92200-7001 | 1 | Washer |

| Ref. No. | Part No. | Qty. | Description |
|----------|----------|------|-------------|
| | | | |

Cooling Equipment Assembly – Kawasaki FH601V-AS23

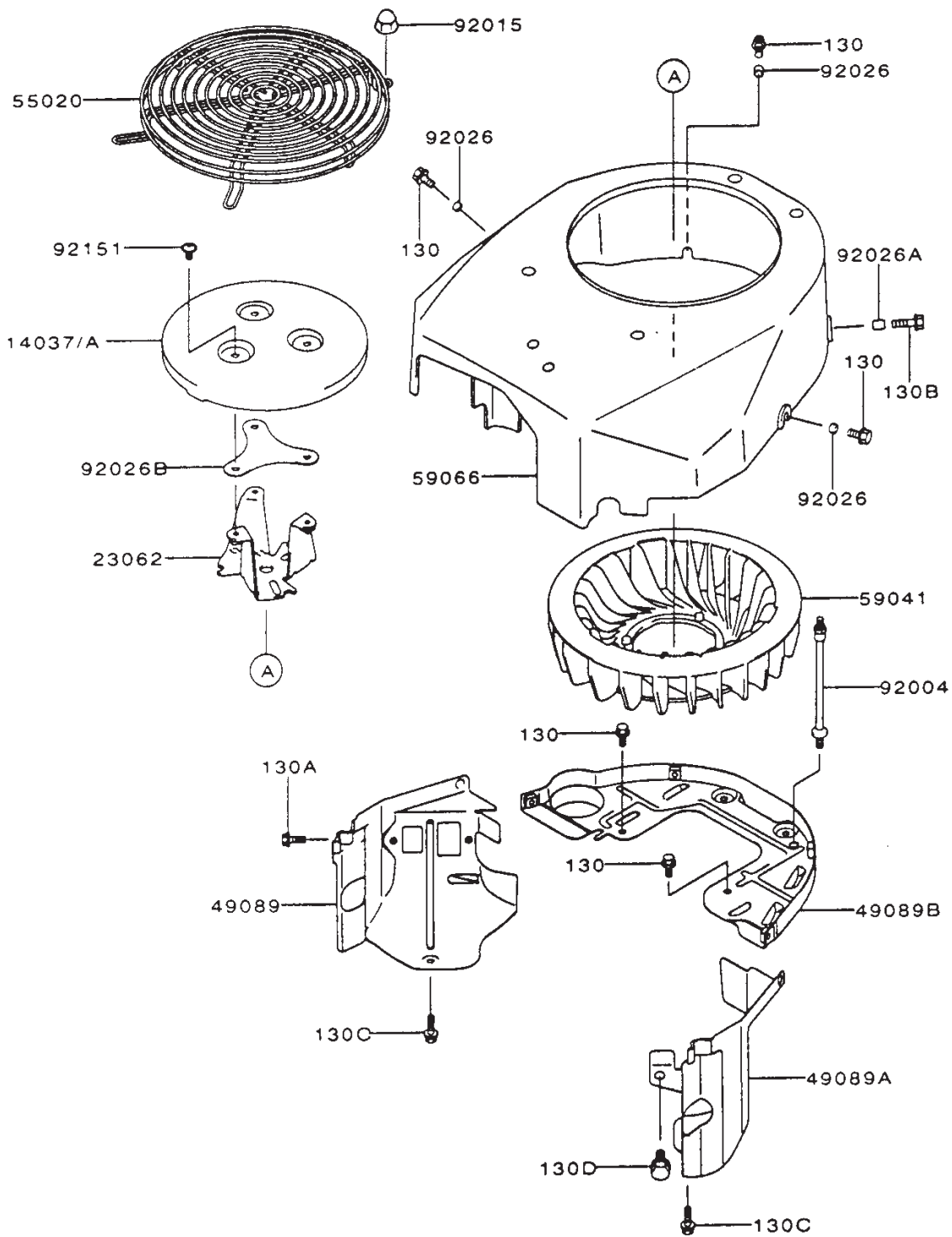

Cooling Equipment Assembly – Kawasaki FH601V–AS23

| Ref. No. | Part No. | Qty. | Description |
|----------|---------------|------|----------------------|
| 13270 | 13270-7007 | 1 | Plate |
| 14037 | 14037-7008-9H | 1 | Screen |
| 14091 | 14091-7002 | 1 | Cover |
| 23062 | 23062-7005 | 1 | Bracket-Comp |
| 49089 | 49089-7004 | 1 | Shroud-Engine |
| 49089A | 49089-7005 | 1 | Shroud-Engine |
| 49089B | 49089-7006 | 1 | Shroud-Engine |
| 55020 | 55020-7002 | 1 | Guard |
| 59041 | 59041-7003 | 1 | Fan |
| 59066 | 59066-7004 | 1 | Housing-Fan |
| 92004 | 92004-2148 | 2 | Stud |
| 92015 | 92015-1170 | 4 | Nut |
| 92026 | 92026-7001 | 3 | Spacer, 6.2x7.9x5 |
| 92026A | 92026-7003 | 1 | Spacer, 6.5x7.9x10.5 |
| 92026B | 92026-7007 | 1 | Spacer |
| 92151 | 92151-7009 | 3 | Bolt, 6x10 |
| 130 | 130B0612 | 5 | Bolt-Flanged |
| 130A | 130B0620 | 2 | Bolt-Flanged |
| 130B | 130B0816 | 1 | Bolt-Flanged |

| Ref. No. | Part No. | Qty. | Description |
|----------|----------|------|-------------|
| | | | |

Electric Equipment Assembly – Kawasaki FH601V-AS23

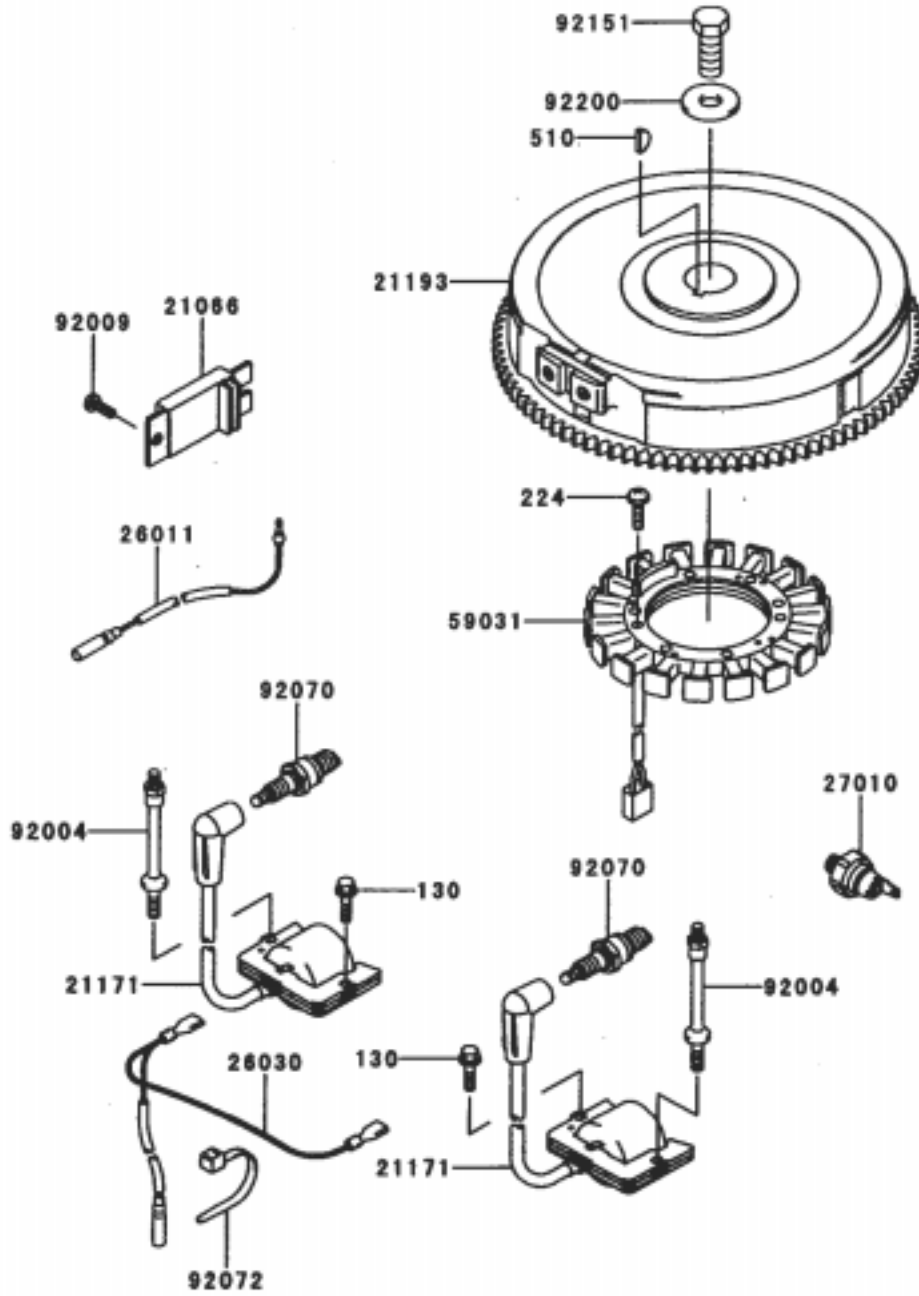

Electric Equipment Assembly – Kawasaki FH601V–AS23

| Ref. No. | Part No. | Qty. | Description |
|----------|------------|------|--------------------|
| 21066 | 21066-7003 | 1 | Regulator-Voltage |
| 21171 | 21171-7001 | 2 | Coil-Assy-Ignition |
| 21193 | 21193-7002 | 1 | Flywheel-Assy |
| 26011 | 26011-7008 | 1 | Wire-Lead |
| 26030 | 26030-7002 | 1 | Harness |
| 27010 | 27010-7001 | 1 | Switch |
| 59031 | 59031-7001 | 1 | Coil-Charging |
| 92004 | 92004-2147 | 2 | Stud |
| 92009 | 92009-2308 | 1 | Screw |
| 92070 | 92070-2088 | 2 | Plug-Spark,BPR5ES |
| 92072 | 92072-7003 | 2 | Band |
| 92151 | 92151-2097 | 1 | Bolt, 12x30 |
| 92220 | 92220-7002 | 1 | Washer |
| 130 | 130B0620 | 1 | Bolt-Flanged |
| 224 | 224B0520 | 4 | Screw-Pan-WP-Cros |
| 510 | 510A5100 | 1 | Key-Woodruff |

| Ref. No. | Part No. | Qty. | Description |
|----------|----------|------|-------------|
| | | | |

Control Equipment Assembly – Kawasaki FH601V-AS23

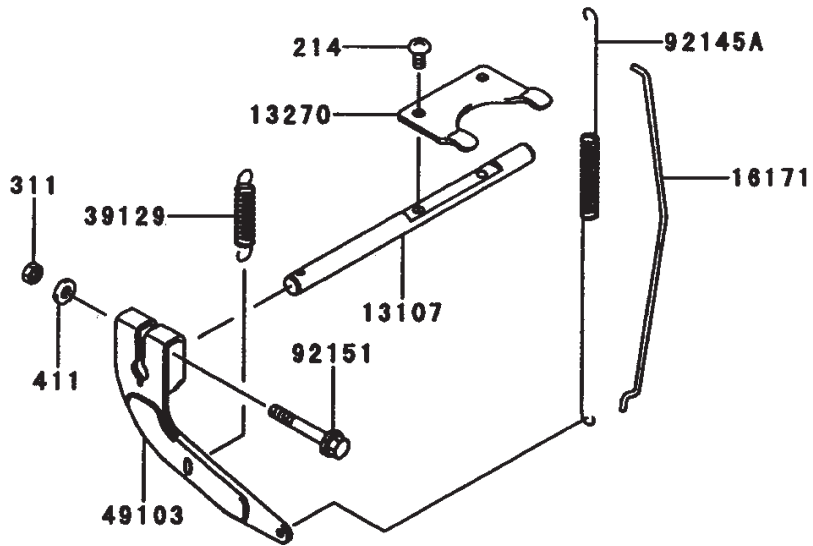
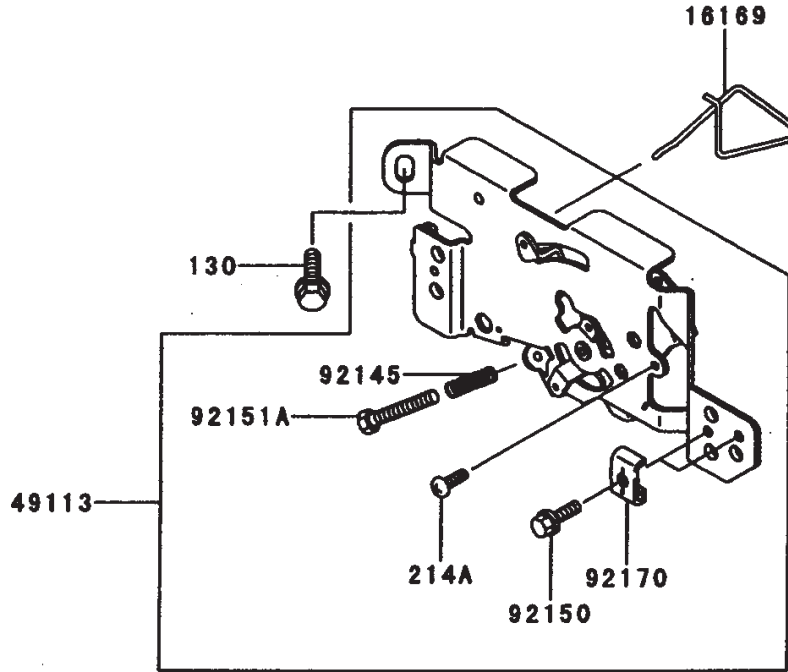

Control Equipment Assembly – Kawasaki FH601V–AS23

| Ref. No. | Part No. | Qty. | Description |
|----------|------------|------|--------------------|
| 13107 | 13107-7004 | 1 | Shaft |
| 13270 | 13270-7006 | 1 | Plate |
| 16169 | 16169-7003 | 1 | Link-Choke |
| 16171 | 16171-7004 | 1 | Link |
| 39129 | 39129-7004 | 1 | Spring-Governor |
| 49103 | 49103-7001 | 1 | Arm-Governor |
| 49113 | 49113-7007 | 1 | Panel-Comp-Control |
| 92145 | 92145-7005 | 1 | Spring |
| 92145A | 92145-7009 | 1 | Spring |
| 92150 | 92150-2182 | 2 | Bolt, 5x18 |
| 92151 | 92151-7006 | 1 | Bolt, 6x30 |
| 92151A | 92151-7014 | 1 | Bolt, 5x30 |
| 92170 | 92170-7001 | 2 | Clamp |
| 130 | 130B0612 | 2 | Bolt-Flanged |
| 214 | 214B0408 | 2 | Screw-Pan |
| 214A | 214B0412 | 1 | Screw-Pan |
| 311 | 311B0600 | 1 | Nut-Hex |
| 411 | 411B0600 | 1 | Washer-Plain |

| Ref. No. | Part No. | Qty. | Description |
|----------|----------|------|-------------|
| | | | |

Carburetor Assembly – Kawasaki FH601V-AS23

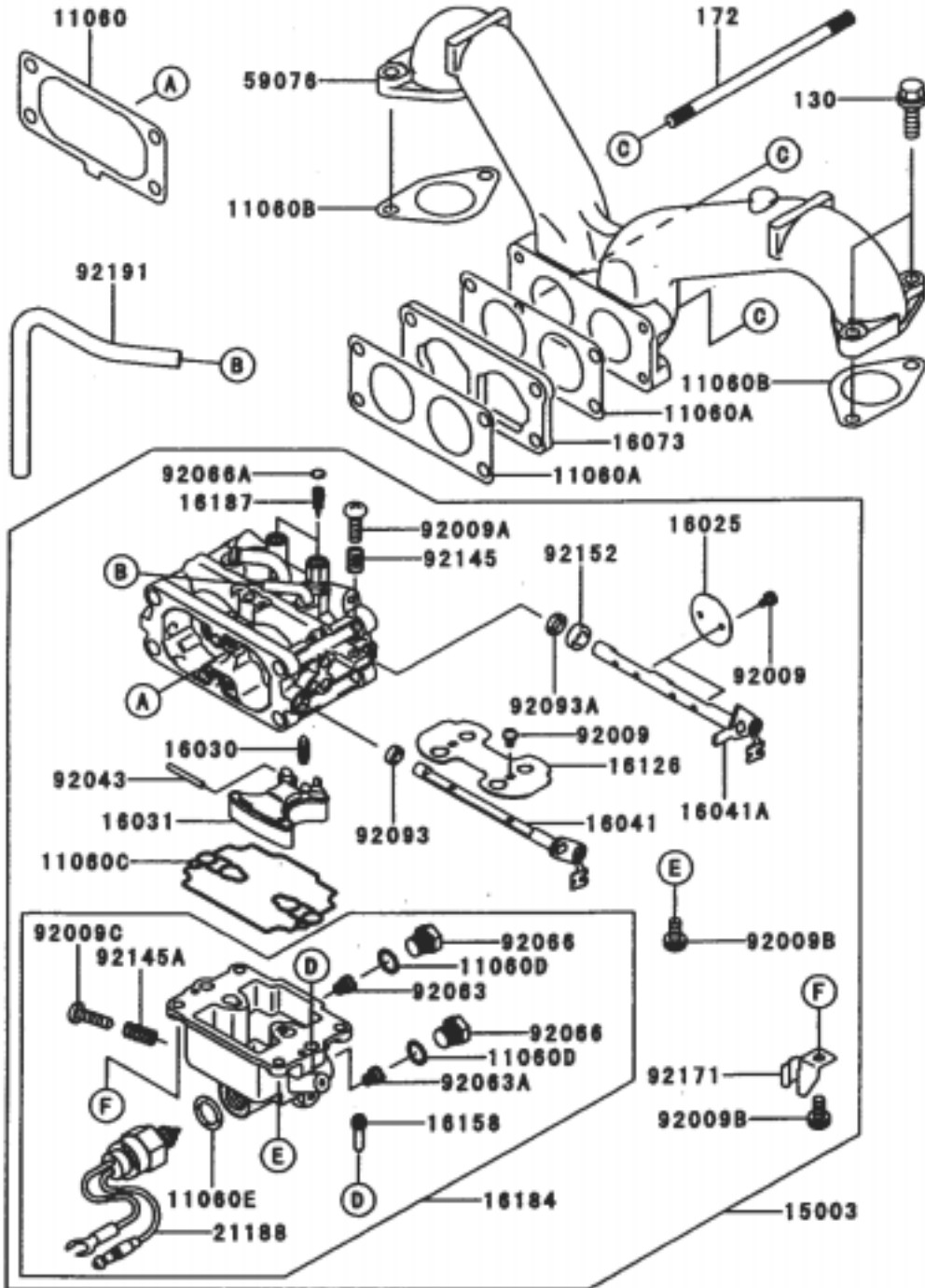

Carburetor Assembly – Kawasaki FH601V–AS23

| Ref. No. | Part No. | Qty. | Description | Ref. No. | Part No. | Qty. | Description |
|----------|------------|------|------------------------------|----------|----------|------|-------------|
| 11060 | 11060-7009 | 1 | Gasket, Air Filter | | | | |
| 11060A | 11060-7010 | 2 | Gasket, Carburetor | | | | |
| 11060B | 11060-7011 | 2 | Gasket | | | | |
| 11060C | 11060-7018 | 1 | Gasket, Float Chamber | | | | |
| 11060D | 11060-7019 | 2 | Gasket, Main Plug | | | | |
| 11060E | 11060-7020 | 1 | Gasket, Solenoid | | | | |
| 15003 | 15003-7001 | 1 | Carburetor-Assy | | | | |
| 16025 | 16025-7001 | 2 | Valve-Throttle | | | | |
| 16030 | 16030-7002 | 1 | Valve-Float | | | | |
| 16031 | 16031-7001 | 1 | Float | | | | |
| 16041 | 16041-7001 | 1 | Shaft-Carburetor, Choke | | | | |
| 16041A | 16041-7002 | 1 | Shaft-Carburetor Throttle | | | | |
| 16073 | 16073-7003 | 1 | Insulator | | | | |
| 16126 | 16126-7004 | 1 | Valve, Choke | | | | |
| 16158 | 16158-7002 | 2 | Jet-Slow, #60 | | | | |
| 16184 | 16184-7001 | 1 | Chamber-Assy-Float | | | | |
| 16187 | 16187-7002 | 2 | Needle-Jet | | | | |
| 21188 | 21188-7001 | 1 | Solenoid | | | | |
| 59076 | 59076-7002 | 1 | Manifold-Intake | | | | |
| 92009 | 92009-7003 | 6 | Screw | | | | |
| 92009A | 92009-7004 | 1 | Screw | | | | |
| 92009B | 92009-7005 | 4 | Screw | | | | |
| 92009C | 92009-7006 | 1 | Screw, Drain | | | | |
| 92043 | 92043-7004 | 1 | Pin-Float | | | | |
| 92063 | 92063-7001 | 1 | Jet-Main, #104 | | | | |
| 92063A | 92063-7002 | 1 | Jet-Main, #106 | | | | |
| 92066 | 92066-7008 | 2 | Plug, Main Jet | | | | |
| 92066A | 92066-7009 | 2 | Plug, Extension | | | | |
| 92093 | 92093-7001 | 1 | Seal | | | | |
| 92093A | 92093-7002 | 2 | Seal | | | | |
| 92145 | 92145-7010 | 1 | Spring | | | | |
| 92145A | 92145-7011 | 1 | Spring | | | | |
| 92152 | 92152-7001 | 1 | Collar | | | | |
| 92171 | 92171-7001 | 1 | Clamp | | | | |
| 92191 | 92191-7010 | 1 | Tube | | | | |
| 130 | 130B0620 | 4 | Bolt-Flanged | | | | |
| 172 | 172G0105 | 2 | Bolt-Stud | | | | |

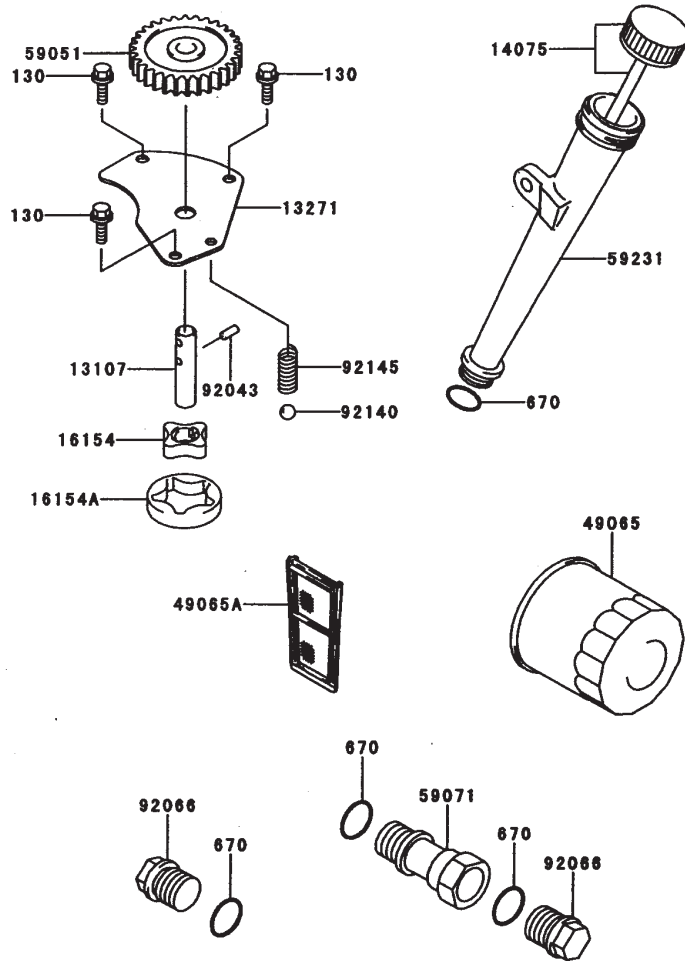

Lubrication Equipment Assembly – Kawasaki FH601V-AS23

| Ref. No. | Part No. | Qty. | Description |
|----------|------------|------|-----------------|
| 13107 | 13107-2099 | 1 | Shaft, Oil Pump |
| 13271 | 13271-7005 | 1 | Plate |
| 14075 | 14075-7002 | 1 | Cap-Assy |
| 16154 | 16154-2053 | 1 | Rotor-Pump, In |
| 16154A | 16154-2054 | 1 | Rotor-Pump, Out |
| 49065 | 49065-2078 | 1 | Filter-Oil |
| 49065A | 49065-7003 | 1 | Filter-Oil |
| 59051 | 59051-7004 | 1 | Gear-Spur |
| 59071 | 59071-7003 | 1 | Joint |
| 59231 | 59231-7002 | 1 | Filler |
| 92043 | 92043-7003 | 1 | Pin |
| 92066 | 92066-7003 | 2 | Plug |
| 92140 | 92140-7003 | 1 | Ball |
| 92145 | 92145-7002 | 1 | Spring |
| 130 | 130B0612 | 3 | Bolt-Flanged |
| 670 | 670D2016 | 4 | O-Ring |

| Ref. No. | Part No. | Qty. | Description |
|----------|----------|------|-------------|
| | | | |
| | | | |
| | | | |
| | | | |
| | | | |
| | | | |
| | | | |
| | | | |
| | | | |
| | | | |
| | | | |

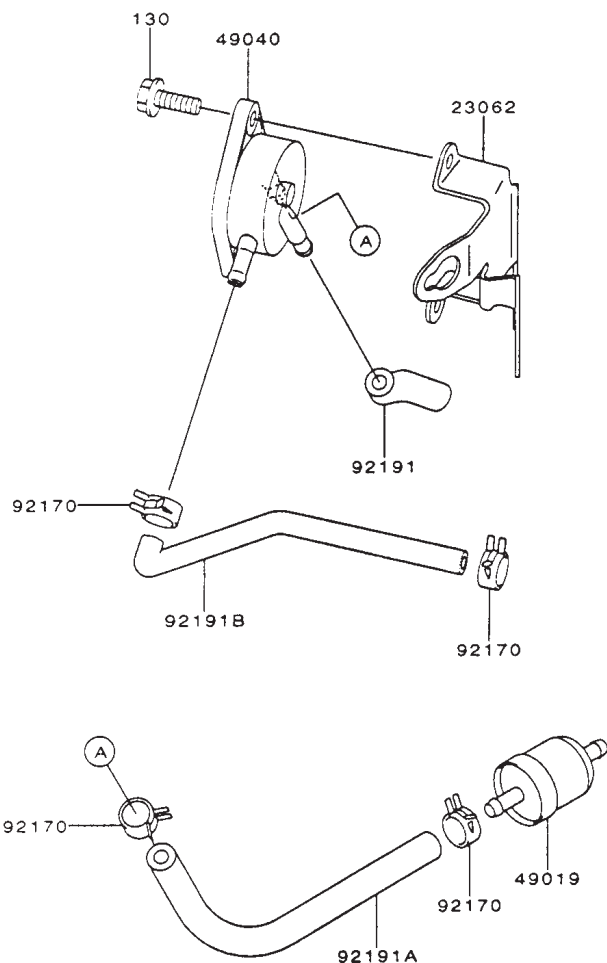

Fuel Tank/Fuel Valve Assembly – Kawasaki FH601V-AS23

| Ref. No. | Part No. | Qty. | Description |
|----------|---------------|------|--------------------|
| 23062 | 23062-7004-9H | 1 | Bracket-Comp |
| 49019 | 49019-7001 | 1 | Filter-Fuel |
| 49040 | 49040-2075 | 1 | Pump-Fuel |
| 92170 | 92170-2088 | 4 | Clamp |
| 92170A | 92170-7003 | 1 | Clamp |
| 92191 | 92191-7003 | 1 | Tube |
| 92191A | 92191-7005 | 1 | Tube,6.35x12.7x160 |
| 92191B | 92191-7007 | 1 | Tube |
| 130 | 130B0616 | 2 | Bolt-Flanged |
| 130A | 130B0620 | 2 | Bolt-Flanged |

| Ref. No. | Part No. | Qty. | Description |
|----------|----------|------|-------------|
| | | | |
| | | | |
| | | | |

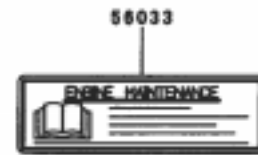
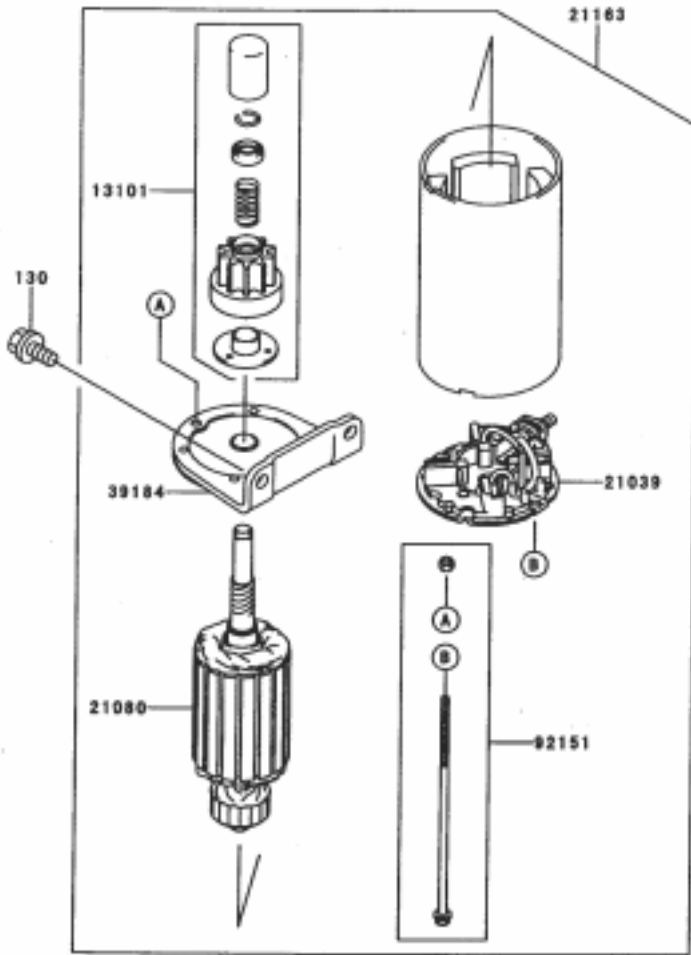

Starter/Decal – Kawasaki FH601V-AS23

| Ref. No. | Part No. | Qty. | Description |
|----------|------------|------|------------------|
| 13101 | 13101-7001 | 1 | Gear-Assy |
| 21039 | 21039-7001 | 1 | Brush |
| 21080 | 21080-7001 | 1 | Armature |
| 21163 | 21163-7001 | 1 | Starter-Electric |
| 39184 | 39184-7001 | 1 | Bracket-Assy |
| 92151 | 92151-7013 | 1 | Bolt |
| 130 | 130B0816 | 1 | Bolt-Flanged |
| 56033 | 56033-7001 | 1 | Decal-Manual |
| 56080 | 56080-7006 | 1 | Decal-Brand |

| Ref. No. | Part No. | Qty. | Description |
|----------|----------|------|-------------|
| | | | |
| | | | |
| | | | |
| | | | |
| | | | |
| | | | |
| | | | |
| | | | |
| | | | |
| | | | |

Maintenance Record

| Date | | | | | | | | |
|------|--|--|--|--|--|--|--|--|
| | | | | | | | | |
| | | | | | | | | |
| | | | | | | | | |
| | | | | | | | | |
| | | | | | | | | |
| | | | | | | | | |
| | | | | | | | | |
| | | | | | | | | |
| | | | | | | | | |
| | | | | | | | | |
| | | | | | | | | |
| | | | | | | | | |
| | | | | | | | | |
| | | | | | | | | |
| | | | | | | | | |
| | | | | | | | | |
| | | | | | | | | |
| | | | | | | | | |
| | | | | | | | | |
| | | | | | | | | |
| | | | | | | | | |

