



**Count on it.**

**Parts Catalog**

**Z Master® Professional 6000  
Series Riding Mower**

**with 72in TURBO FORCE® Side Discharge  
Mower**

Model No. 72968—Serial No. 412413921 and Up



# Ordering Replacement Parts

To order replacement parts, please supply the part number, the quantity, and the description of each part desired.

## Understanding Reference Numbers

Each identified part in an illustration has a reference number. The reference number for a part also appears in the parts list, along with other information about the part.

This catalog uses two special reference number formats, one to indicate parts in a service assembly and another to indicate the quantity of a given part in an illustration.

## Service Assembly Reference Numbers

Parts in service assemblies have reference numbers in the form a:b. The a represents the reference number of the entire service assembly and the b represents a sequential number unique to each part within the service assembly.

For example, a wheel assembly might be identified by reference number 6, the tire by 6:1, the valve by 6:2, and the wheel by 6:3. When you order the assembly identified by reference number 6, you receive all parts identified by reference numbers 6:1, 6:2, and 6:3. However, you may also order any part individually. Reference numbers of this type appear in illustration and in parts lists.

## Reference Numbers Indicating Quantity

In an illustration, if a reference number indicates more than one part, the reference number has the form nX y. The n represents the quantity of the part, the X is the multiplication symbol, and the y represents the reference number.

For example, in an illustration, the reference number 2X 37 means that two of the parts identified by reference number 37 are indicated.

# Contents

Seat Frame Suspension Assembly . . . . .	4
Main Frame Assembly . . . . .	6
Roll-Over Protection System Assembly No. 116-0231 . . . . .	8
Caster Fork and Wheel Assembly . . . . .	10
Hydraulic Drive Assembly . . . . .	12
Pump Idler Assembly No. 116-1255 . . . . .	14
LH Hydro Assembly No. 135-7907 . . . . .	16
RH Hydro Assembly No. 135-7908 . . . . .	18
Rear Wheel Assembly . . . . .	20
Park Brake Assembly . . . . .	22
Fuel System Assembly . . . . .	24
Fuel Tank Assembly No. 135-0643 . . . . .	26
Seat Mounting Assembly . . . . .	28
Seat Assembly No. 139-3641 . . . . .	30
Motion Controls Assembly . . . . .	32
Console Assembly . . . . .	34
RH Console Assembly No. 115-7400 . . . . .	36
LH Console Assembly No. 115-7401 . . . . .	38
Electrical Assembly . . . . .	40
Deck Lift Assembly . . . . .	42
Height-of-Cut Assembly No. 109-7438 . . . . .	44
Engine, Clutch and Muffler Assembly . . . . .	46
Deck Assembly . . . . .	48
Deck Decal Assembly No. 140-1170 . . . . .	50
Rubber Deflector Assembly No. 108-2792 . . . . .	52
Idler Arm Assembly . . . . .	54
Frame Decal Assembly . . . . .	56
Attachments and Accessories . . . . .	58

# Seat Frame Suspension Assembly

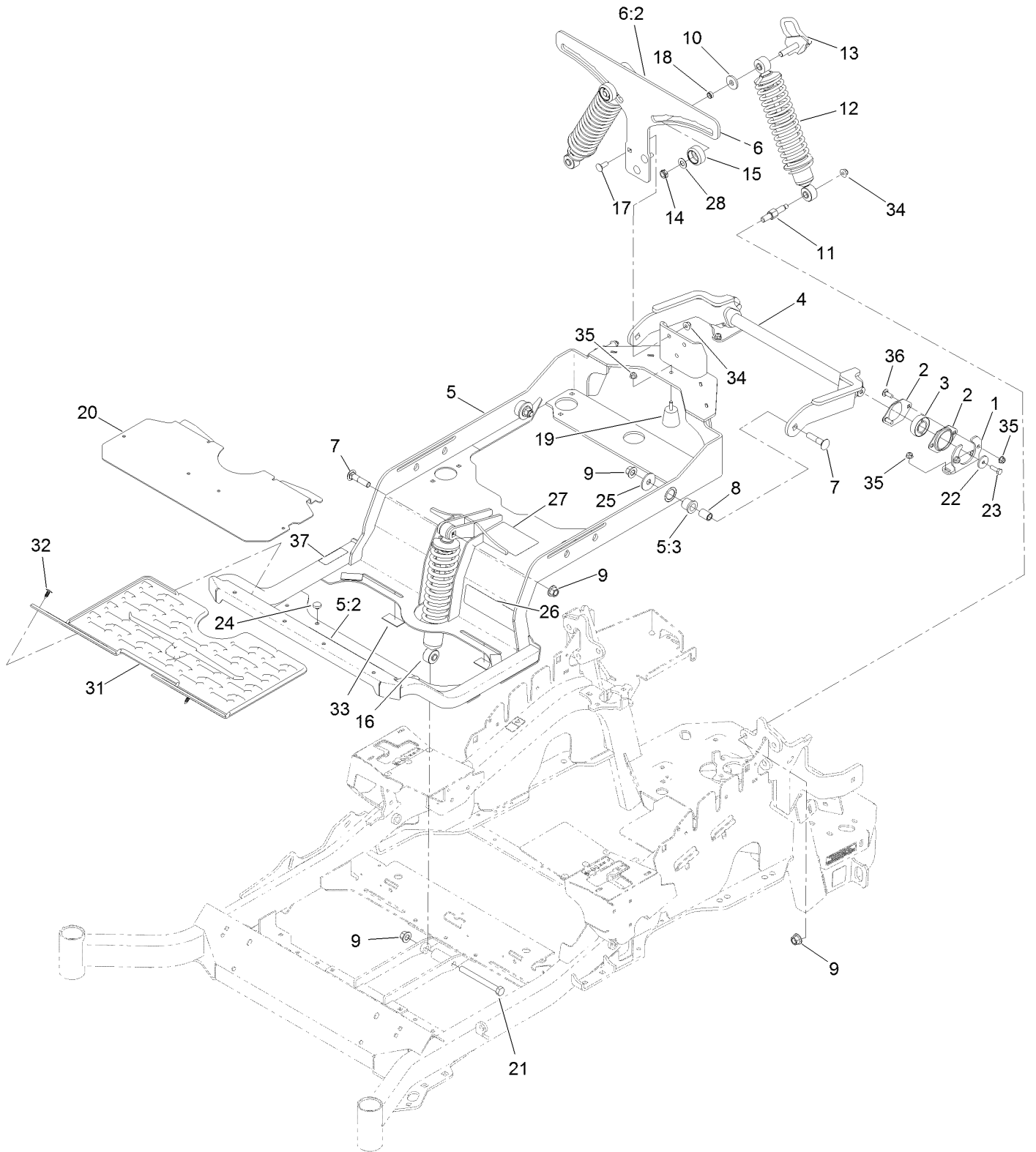

## Seat Frame Suspension Assembly (continued)

<i>Ref.</i>	<i>Part Number</i>	<i>Qty.</i>	<i>Description</i>	<i>Ref.</i>	<i>Part Number</i>	<i>Qty.</i>	<i>Description</i>
1	127-6759-03	2	Bracket-Bearing	17	3231-22	3	Screw-CARR
2	127-6743	4	Housing-Bearing, Flange	18	133-5109	2	Bearing-Sleeve
3	1-653346	2	Bearing	19	132-5058	1	Bumper-Rubber
4	127-6754-03	1	Arm-Trailing	20	144-0381-01	1	Floorpan
5	140-4868	1	Subframe ASM	21	325-19	1	Screw-HH
5:2	132-0871	1	Decal-Danger	22	105-3048	2	Washer-Flat
5:3	127-6745	2	Bushing-Flange	23	116-0648	2	Screw-HH, Thread Locking
6	144-2602	1	Bracket-Mounting	24	1-513658	2	Bumper
6:2	132-5067	1	Decal-Adjustment, Ride	25	86-1990	2	Washer-Thrust
7	127-6768	3	Screw-CARR	26	144-0437	1	Decal-Myride
8	127-6751	2	Spacer-Aluminum	27	125-9383	1	Decal-Service Aid
9	99-5107	6	Nut-Lock	28	3-6803	2	Washer-Adjusting
10	131-4699	2	Washer-Plastic	31	144-0355	1	Floormat-Myride
11	131-6348	2	Bolt-Shoulder	32	117-2382	2	Plug-Plastic
12	133-1815	2	Shock/Spring ASM	33	130-0733	4	Pad-Rubber
13	136-9017	2	Cam Lock ASM	34	104-8301	5	Nut-HF, NI
14	3296-45	2	Nut-Hex	35	104-8300	9	Nut-HF, NI
15	136-5636	2	Knob-Lock, Cam	36	3230-10	4	Bolt-CARR
16	136-1719	1	Shock ASM-Front	37	115-9625	1	Decal-Brake, Parking
16	136-8993	1	Shock/Spring ASM				

# Main Frame Assembly

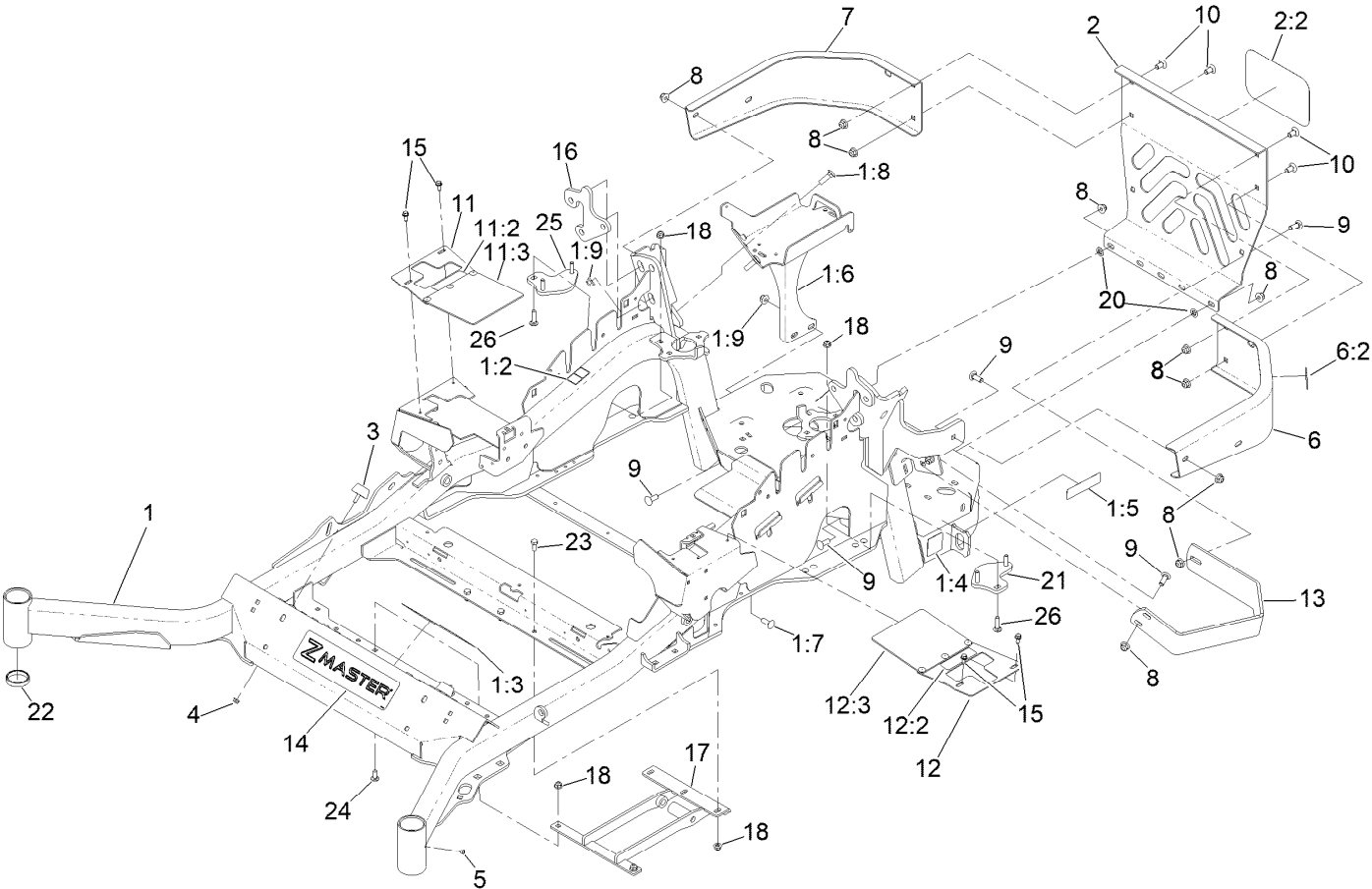

## Main Frame Assembly (continued)

<i>Ref.</i>	<i>Part Number</i>	<i>Qty.</i>	<i>Description</i>	<i>Ref.</i>	<i>Part Number</i>	<i>Qty.</i>	<i>Description</i>
1	142-7266	1	Mainframe Service ASM - 72	11	131-4615	1	RH Motion Control Cover ASM
1:2	106-5517	2	Decal-Warning	11:2	99-8936	1	Decal-Control, Motion
1:3	132-0871	1	Decal-Danger	11:3	136-8967	1	Flap-Rubber
1:4	106-2655	2	Decal-Hazard, Pinched Finger	12	131-4610	1	LH Motion Control Cover ASM
1:5	133-8062	1	Decal-Arrestor, Spark	12:2	99-8936	1	Decal-Control, Motion
1:6	142-6404-01	1	Battery Mount ASM [red]	12:3	136-8967	1	Flap-Rubber
1:7	3231-22	2	Screw-CARR	13	126-2067-03	1	Guard-Muffler
1:8	3231-25	2	Bolt-CARR	14	140-1215	1	Decal-Console
1:9	104-8301	4	Nut-HF, NI	15	32144-10	4	Screw-HWH
2	115-7410	1	Rear Guard ASM	16	136-1674-01	2	Plate-Mount, Shock
2:2	67-7320	1	Decal	17	131-6327-01	1	Mount-Lower
3	131-8834	2	Bumper	18	104-8300	7	Nut-HF, NI
4	104-7201	4	Nut-HF, NI	20	107-3154	2	Nut-Push
5	1-811010	2	Plug	21	127-6766	1	LH Plate ASM (W/Studs)
6	116-0180	1	LH Bumper ASM	22	1-543508	4	Cup-Bearing
6:2	106-5517	1	Decal-Warning	23	322-3	3	Screw-HH
7	116-0057-03	1	Bumper-RH	24	3230-23	2	Bolt-CARR
8	104-8301	15	Nut-HF, NI	25	127-6765	1	RH Plate ASM (W/Studs)
9	3231-22	9	Screw-CARR	26	3230-3	2	Screw-CARR
10	3231-21	4	Screw-CARR				

# Roll-Over Protection System Assembly No. 116-0231

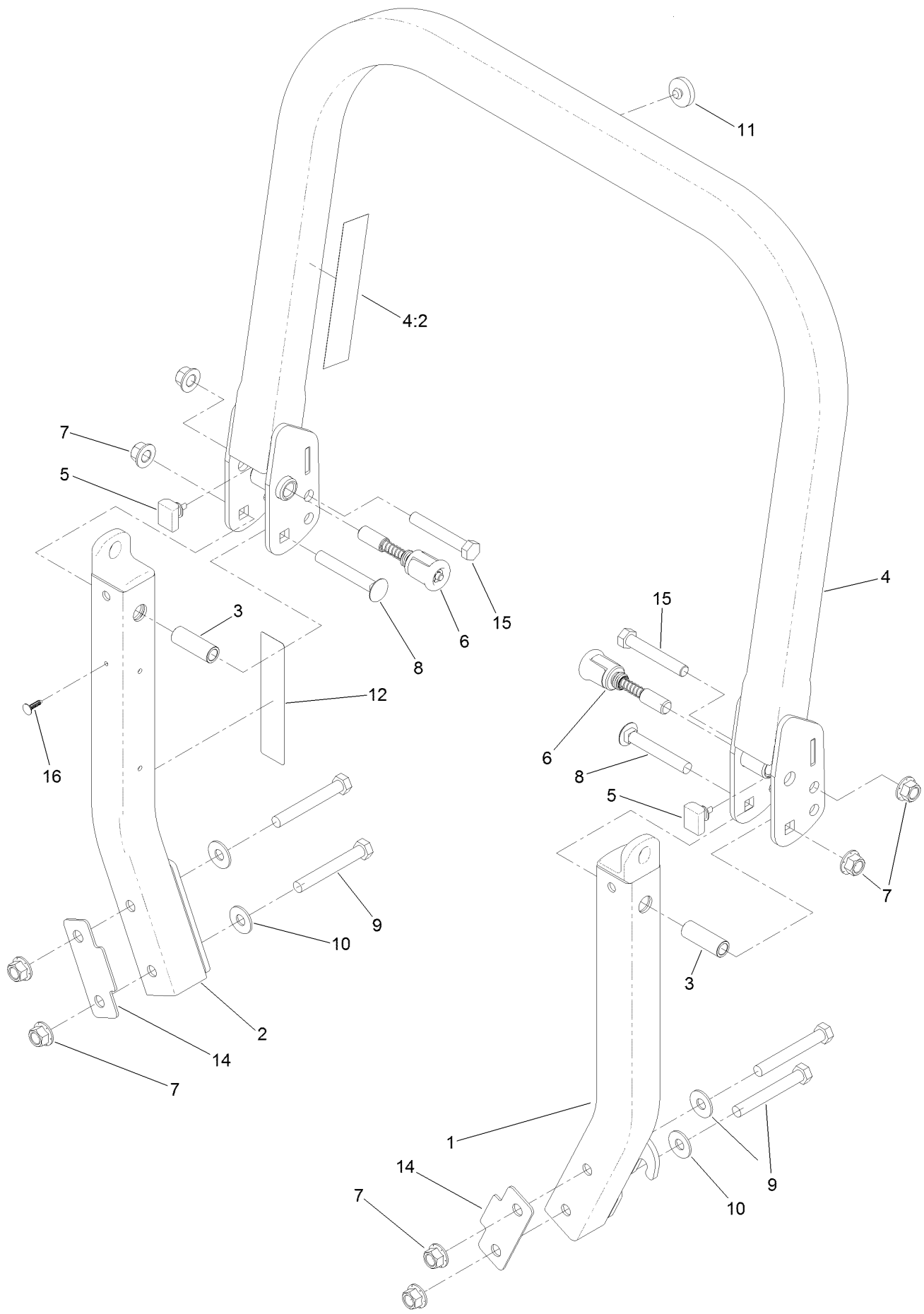



# Roll-Over Protection System Assembly No. 116-0231 (continued)

<i>Ref.</i>	<i>Part Number</i>	<i>Qty.</i>	<i>Description</i>	<i>Ref.</i>	<i>Part Number</i>	<i>Qty.</i>	<i>Description</i>
1		1	Leg-ROPS, LH ●	8	3233-10	2	Screw-CARR
2		1	Leg-ROPS, RH ●	9	325-35	4	Screw-HH
3	109-6653	2	Spacer	10	109-9505	4	Washer-Spring
4		1	Upper ROPS ASM ●	11	109-9233	1	Bumper-Push-In, Rubber
4:2	107-3069	1	Decal-Warning	12	117-0346	1	Decal-Caution, Fuel Vent
5	109-5337	2	Bumper-ROPS	14	116-0960	2	Spacer
6	116-0104	2	Pin-Spring	15	325-13	2	Screw-HH
7	99-5107	8	Nut-Lock	16	125-8067	1	Plug-Plastic

● Not serviced separately

# Caster Fork and Wheel Assembly



## Caster Fork and Wheel Assembly (continued)

<i>Ref.</i>	<i>Part Number</i>	<i>Qty.</i>	<i>Description</i>	<i>Ref.</i>	<i>Part Number</i>	<i>Qty.</i>	<i>Description</i>
1	1-543509	2	Bearing-Roller, Tapered	5:2:3	103-3051	1	Spacer-Nut ■
2	116-5647	1	Seal-Grease	5:2:4	126-5361	1	Axle Caster ASM
3	1-633508	3	Washer-Bellville	5:2:5		1	Wheel And Tire ASM ●
4	116-6707-01	1	Caster	5:2:5:1	1-633584	2	Bearing-Cup
5	127-9528	1	Wheel And Axle ASM	5:3	325-39	1	Screw-HH
5:1	103-2768	2	Guard-Seal	5:4	3296-23	1	Nut-Lock, NI
5:2		1	Wheel And Bearing ASM ●	6	103-4882	1	Cap-Grease
5:2:1	1-633585	2	Bearing-Cone, Taper	7	3296-51	1	Nut-Lock, NI
5:2:2	103-0063	2	Seal-Caster				

● Not serviced separately

■ Use Pro-Lock, Nut Type (P/N 1-840022, .5ml tube) on threads.

# Hydraulic Drive Assembly

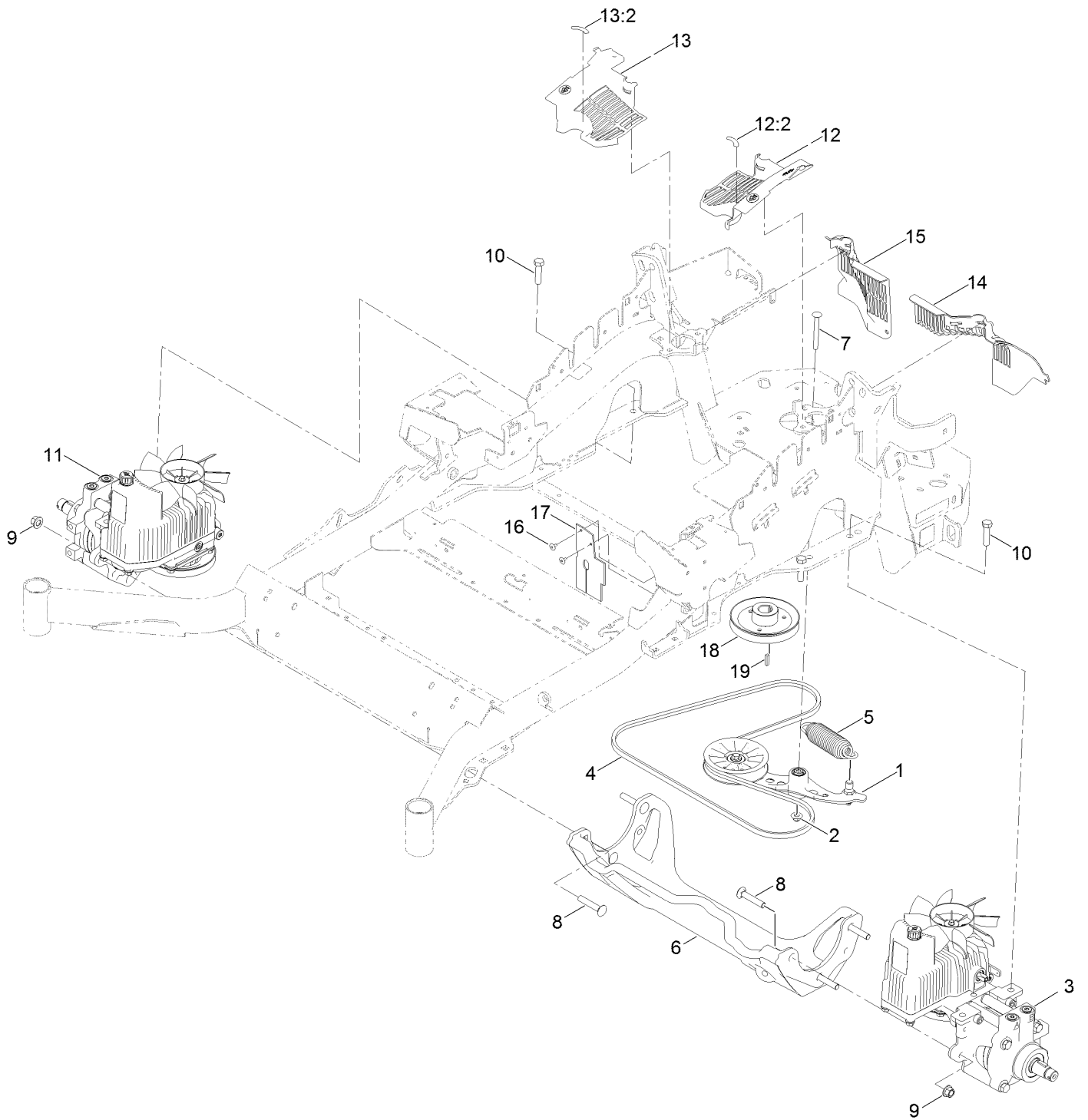

## Hydraulic Drive Assembly (continued)

<i>Ref.</i>	<i>Part Number</i>	<i>Qty.</i>	<i>Description</i>	<i>Ref.</i>	<i>Part Number</i>	<i>Qty.</i>	<i>Description</i>
1	116-1255	1	Pump Idler ASM	13	116-0171	1	RH Hydro Guard ASM
2	109-6658	1	Nut-Flange, NI	13:2	116-8726	1	Decal-Oil, Hydro
3	135-7907	1	Hydro-LH	14	109-9709	1	Guard-Hydro, Rear Trim (LH)
4	126-9835	1	Belt-V	15	109-9058	1	Guard-Hydro, Rear (RH)
5	116-6317	1	Spring-Extension	16	1-803035	2	Rivet-Pop
6	116-7558	1	Cradle-Hydro	17	116-2362	1	Deflector-Air Flow
7	116-1502	1	Bolt-Shoulder, Carriage	18	109-9905	1	Sheave
8	126-0095	6	Screw-CARR	19	1-807259	1	Key
9	99-5107	6	Nut-Lock	99	114-4713	1	Hypr-Oil 500 (Quart) ●
10	325-8	4	Screw-HH	99	114-4714	1	Hypr-Oil 500 (Gallon) ●
11	135-7908	1	Hydro-RH	99	114-4715	1	Hypr-Oil 500-5 (5 Gallon) ●
12	116-0170	1	LH Hydro Guard ASM	99	117-0390	1	Filter-Hydro ●
12:2	116-8726	1	Decal-Oil, Hydro				

● Not illustrated

# Pump Idler Assembly No. 116-1255

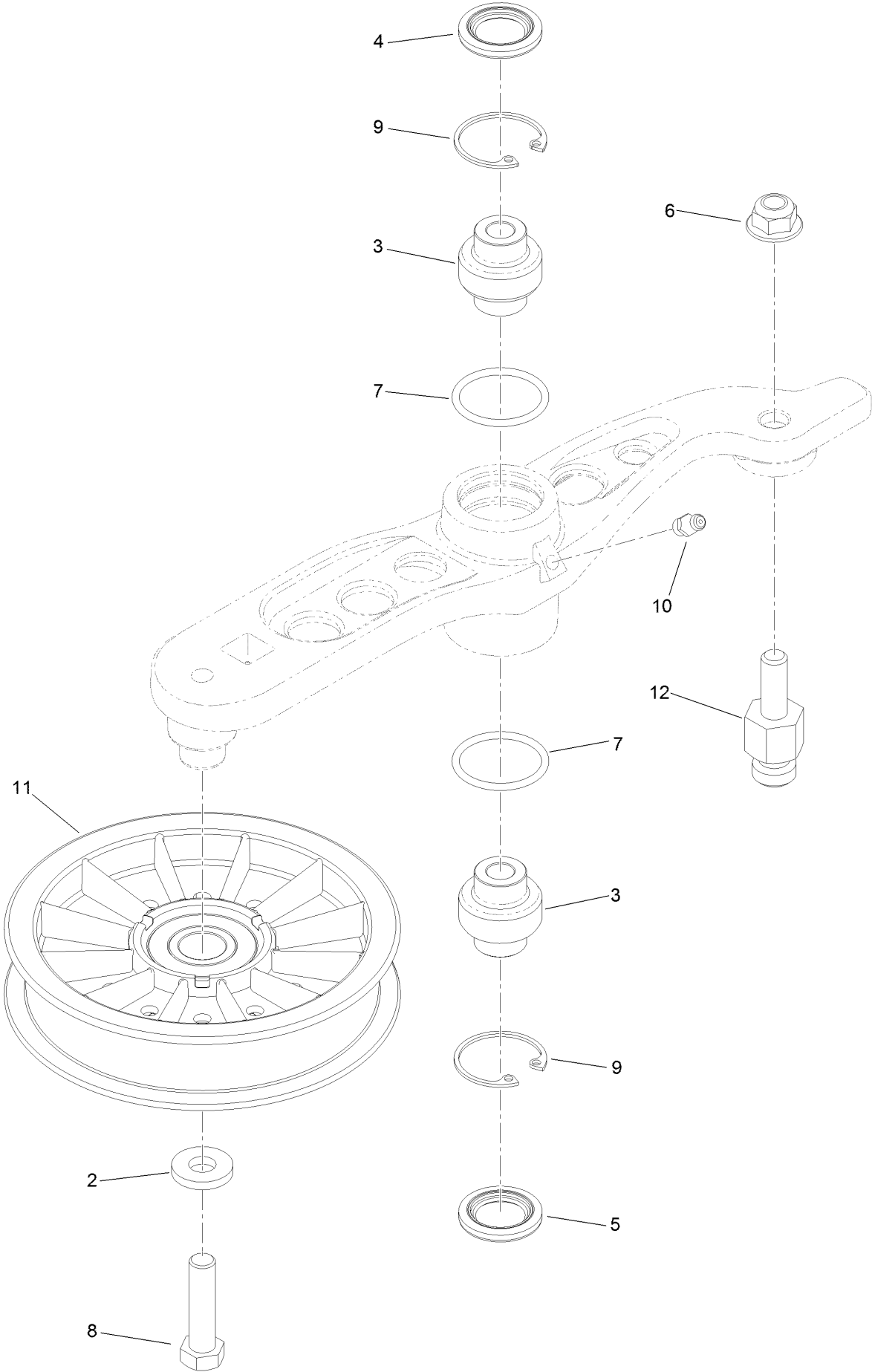

## Pump Idler Assembly No. 116-1255 (continued)

<i>Ref.</i>	<i>Part Number</i>	<i>Qty.</i>	<i>Description</i>	<i>Ref.</i>	<i>Part Number</i>	<i>Qty.</i>	<i>Description</i>
2	43-0940	1	Spacer	8	323-8	1	Screw-HH
3	103-3504	2	Bearing-Spherical	9	32120-10	2	Ring-Snap
4	103-3505	1	Seal-Lip, Double	10	302-19	1	Fitting-Grease
5	103-3506	1	Seal-Lip, Single	11	109-8076	1	Pulley-Idler
6	109-6658	1	Nut-Flange, NI	12	132-4724	1	Pin-Anchor, Spring
7	106-7159	2	O-Ring				

# LH Hydro Assembly No. 135-7907

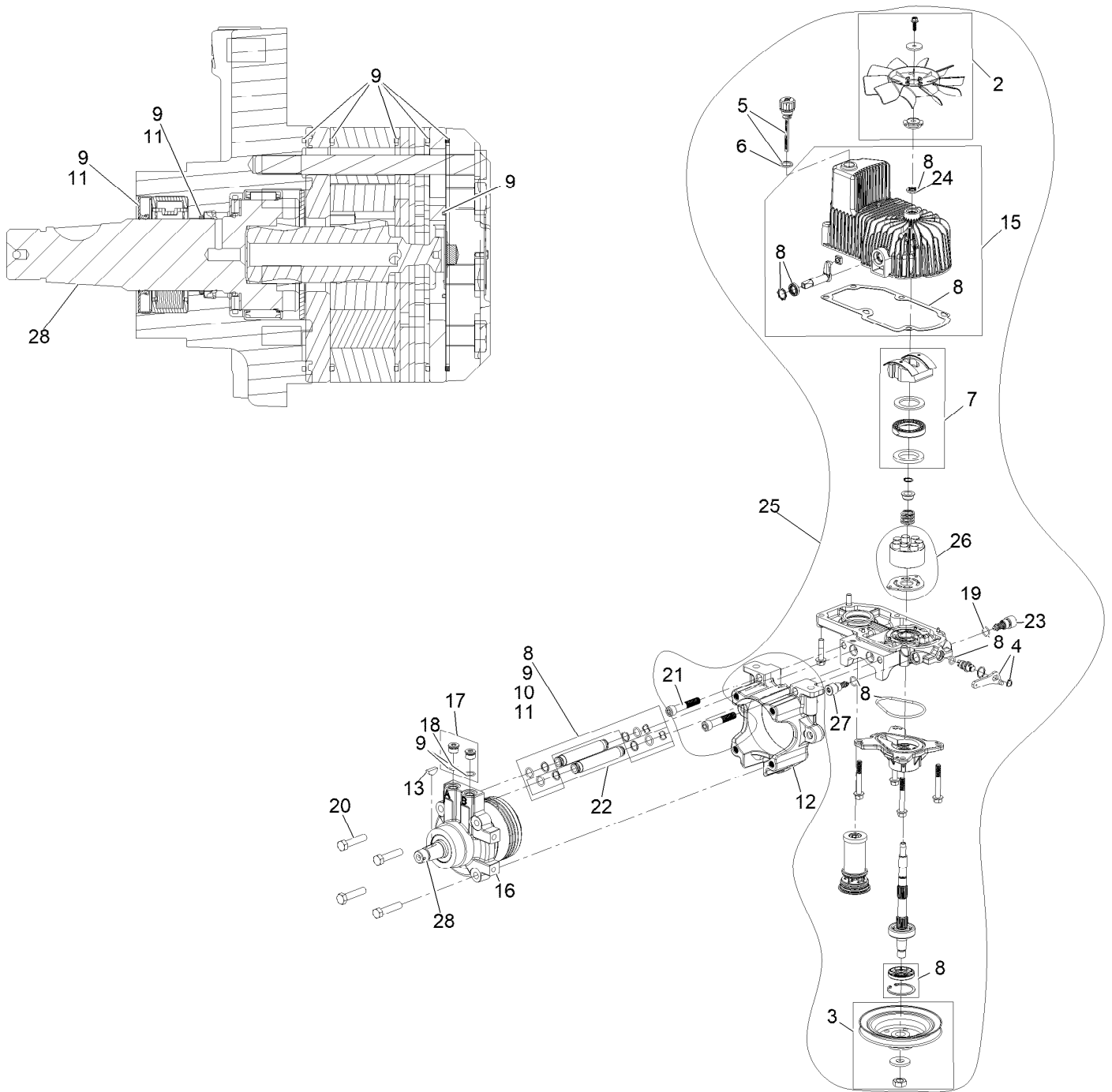



## LH Hydro Assembly No. 135-7907 (continued)

<i>Ref.</i>	<i>Part Number</i>	<i>Qty.</i>	<i>Description</i>	<i>Ref.</i>	<i>Part Number</i>	<i>Qty.</i>	<i>Description</i>
2	142-3603	1	Kit, 7.8 In Fan	17	116-7901	1	Magnetic Plugs Service Kit
3	116-0234	1	Pulley Kit	18	76-1900	2	O-Ring
4	116-0235	1	Handle	19	116-8662	2	O-Ring-Valve, Check
5	116-0236	1	Dipstick	20	116-8974	4	Screw-HH 1/2-20 X 2 1/4
6	116-0237	1	Gasket	21	116-8975	2	Screw-HSH 1/2-20 X 2 3/4
7	116-1367	1	Swash Block Kit	22	116-9922	2	Hydraulic Tube Kit
8	142-3604	1	Kit, Pump Seal	23	126-7467	1	Shock Valve, 16Cc Hydro
9	116-1369	1	Motor Seal Kit	24	126-7711	1	Seal-Drive, Fan
10	116-1370	1	Tube Seal Kit	25	142-3607	1	Kit, Pump Section 16Cc LH
11	116-1371	1	Output Shaft Seal Kit	26	142-4501	1	Kit - 16Cc Port Plate, Rotate Grp
12	116-5469	1	Cup-Nose				
13	3257-42	1	Key-Woodruff 5/16 X 1	27	142-4458	1	Shock Valve Orificed 3300
15	142-4460	1	Kit, Housing-Hydro LH	28	146-3749	1	Output Shaft- TI Uht Motor
16	146-1948	1	HYD Motor, 280Cc LH Sealed	99	116-1373	1	Flow Test Kit ●

● Not illustrated

# RH Hydro Assembly No. 135-7908

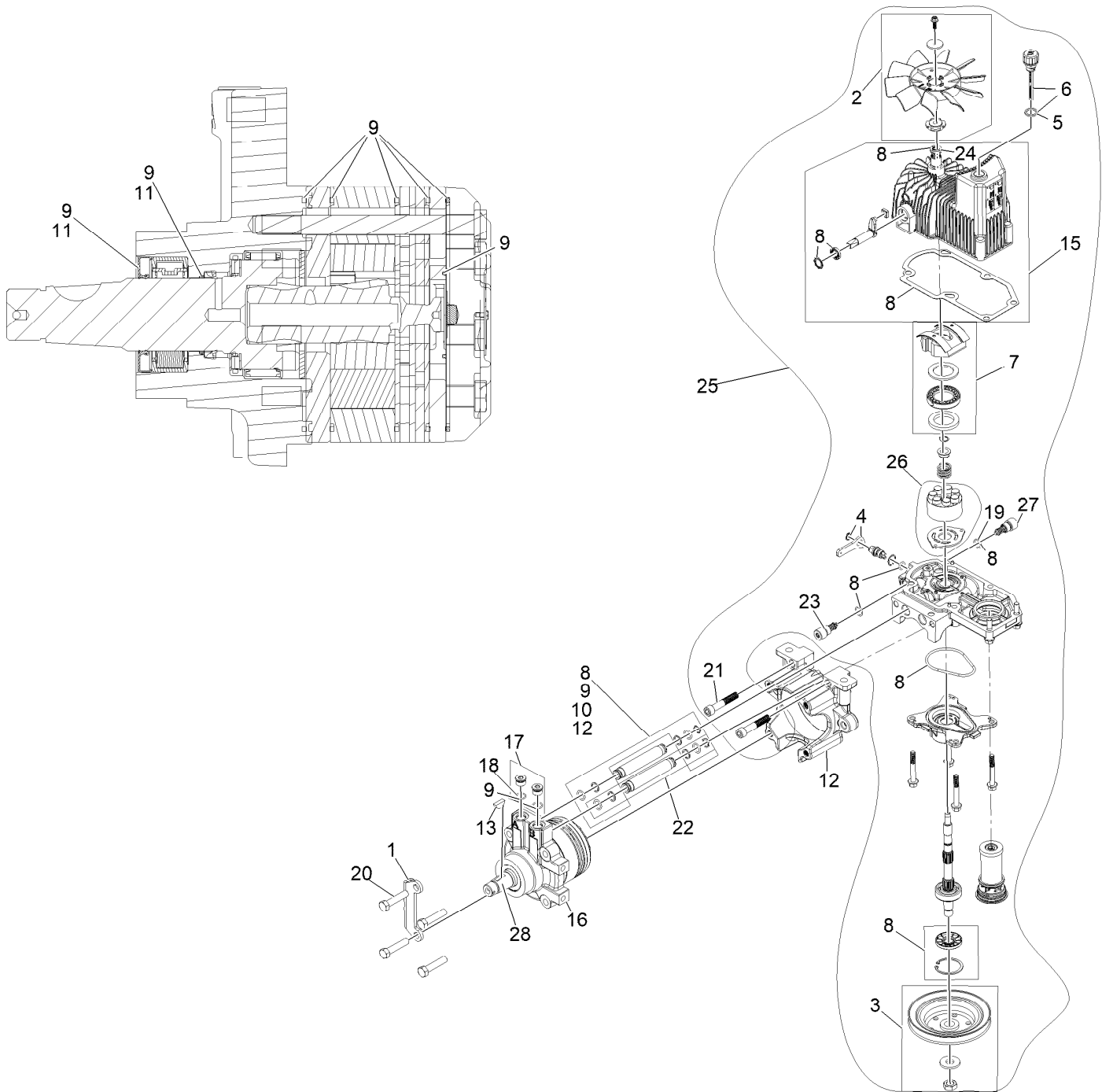

## RH Hydro Assembly No. 135-7908 (continued)

<i>Ref.</i>	<i>Part Number</i>	<i>Qty.</i>	<i>Description</i>	<i>Ref.</i>	<i>Part Number</i>	<i>Qty.</i>	<i>Description</i>
1	135-7827	1	Plate, Horse Shoe Mount	17	116-7901	1	Magnetic Plugs Service Kit
2	142-3603	1	Kit, 7.8 In Fan	18	76-1900	2	O-Ring
3	116-0234	1	Pulley Kit	19	116-8662	2	O-Ring-Valve, Check
4	116-0235	1	Handle	20	116-8974	4	Screw-HH 1/2-20 X 2 1/4
5	116-0237	1	Gasket	21	116-8975	2	Screw-HSH 1/2-20 X 2 3/4
6	116-0236	1	Dipstick	22	116-9922	2	Hydraulic Tube Kit
7	116-1367	1	Swash Block Kit	23	126-7467	1	Shock Valve, 16Cc Hydro
8	142-3604	1	Kit, Pump Seal	24	126-7711	1	Seal-Drive, Fan
9	116-1369	1	Motor Seal Kit	25	142-3606	1	Kit, Pump Section 16Cc RH
10	116-1370	1	Tube Seal Kit	26	142-4501	1	Kit - 16Cc Port Plate, Rotate Grp
11	116-1371	1	Output Shaft Seal Kit				
12	116-5469	1	Cup-Nose	27	142-4458	1	Shock Valve Orificed 3300
13	3257-42	1	Key-Woodruff 5/16 X 1	28	146-3749	1	Output Shaft- TI Uht Motor
15	142-4461	1	Kit, Housing-Hydro RH	99	116-1373	1	Flow Test Kit ●
16	146-1947	1	HYD Motor, 280Cc RH Sealed	99	116-4245	1	Puller-Pulley

● Not illustrated

# Rear Wheel Assembly

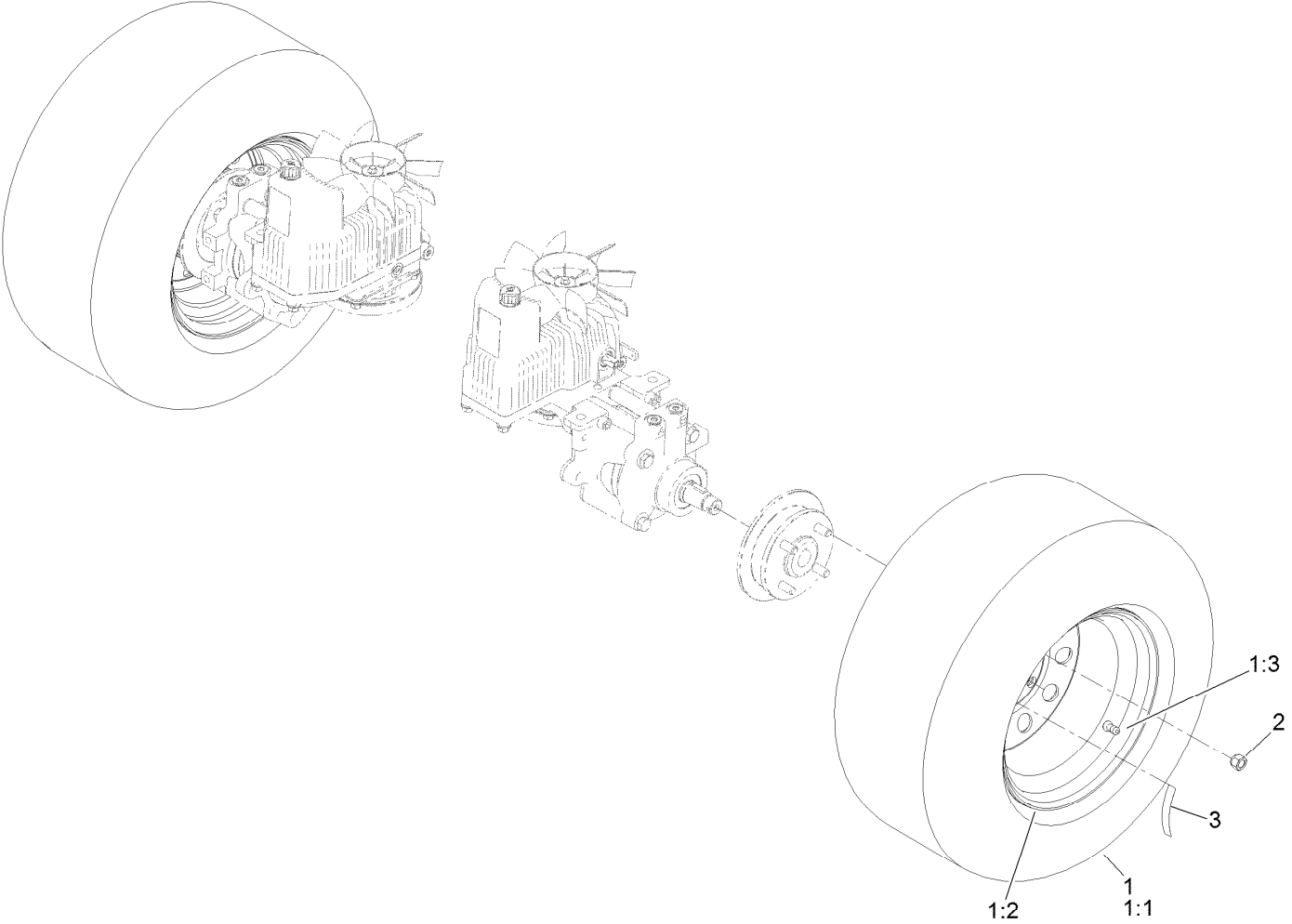

## Rear Wheel Assembly (continued)

<i>Ref.</i>	<i>Part Number</i>	<i>Qty.</i>	<i>Description</i>	<i>Ref.</i>	<i>Part Number</i>	<i>Qty.</i>	<i>Description</i>
1	127-9521	2	Wheel And Tire ASM	2	242-50	8	Nut-Lug
1:1	1-633993	1	Tire	3	126-2055	2	Decal-Torque, Wheel Hub Lug
1:2	127-9522	1	Wheel				
1:3	232-27	1	Stem-Valve				

# Park Brake Assembly

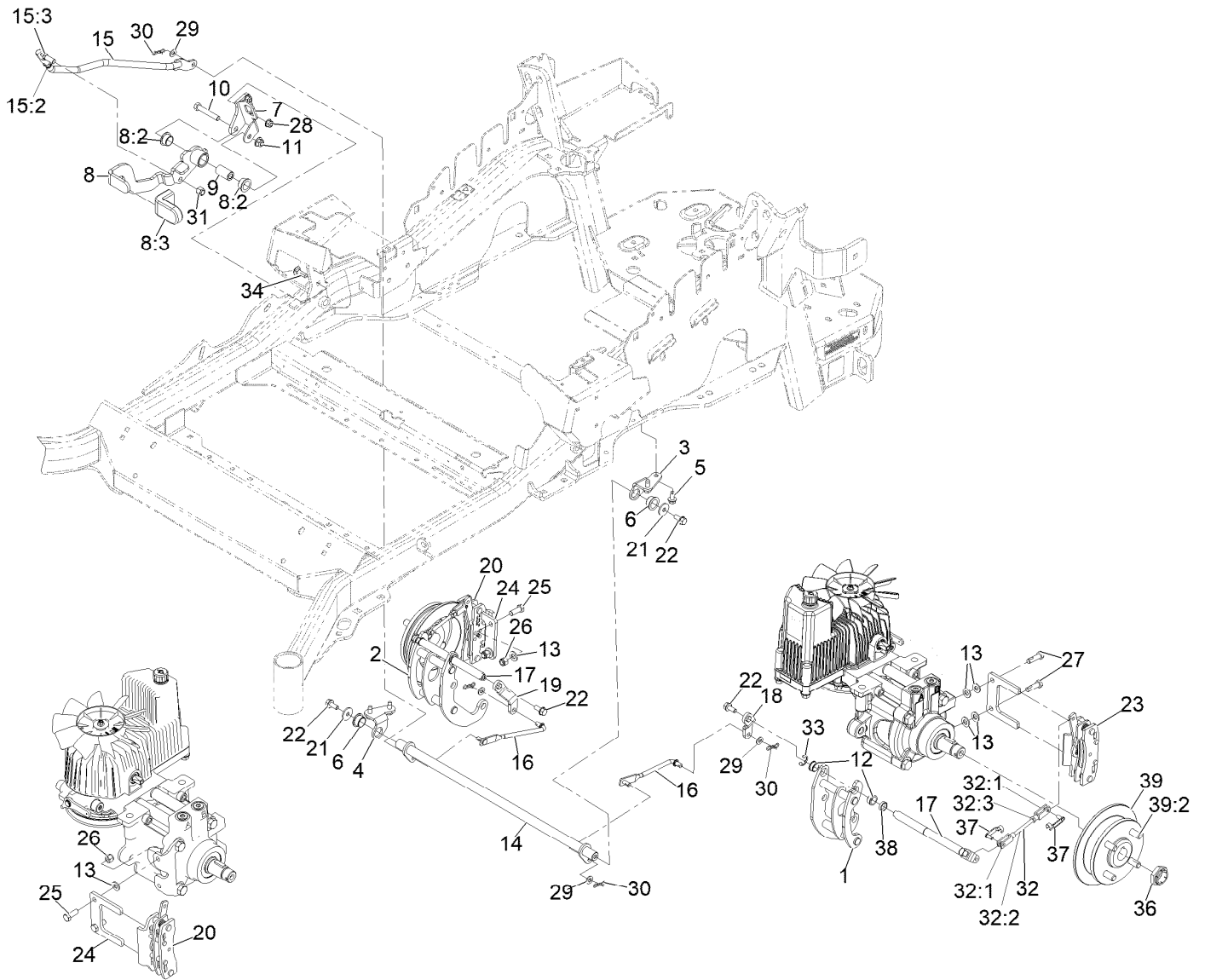

REAR VIEW OF  
RIGHT HAND HYDRO

## Park Brake Assembly (continued)

<i>Ref.</i>	<i>Part Number</i>	<i>Qty.</i>	<i>Description</i>	<i>Ref.</i>	<i>Part Number</i>	<i>Qty.</i>	<i>Description</i>
1	126-4248	1	Mount-Bellcrank, LH	19	126-3716	1	Arm-Inner, RH
2	126-4249	1	Mount-Bellcrank, RH	20	135-7440	1	Caliper-Brake, RH
3	116-9681	1	Mount-Pivot, LH	21	115-7109	2	Washer-Flat
4	116-9682	1	Mount-Pivot, RH	22	98-9940	4	Screw-HHF
5	32144-70	4	Screw-HWH 5/16-18 X 3/4 Tf	23	135-7441	1	Caliper-Brake, LH
6	109-8054	2	Bushing-Flanged	24	135-7828	2	Plate-Mount, Brake
7	116-9096-01	1	Bracket-Mount	25	135-7915	2	Screw-HH,
8	135-7982	1	Brake Lever ASM W/Grip M-R	26	112-0236	2	Nut-Lock
8:2	109-8054	2	Bushing-Flanged	27	135-7890	2	Screw-HH, Patch,
8:3	132-4749	1	Grip-Lever	28	104-8300	2	Nut-Nyloc 5/16-18 Flg
9	116-9117	1	Pivot-Handle, Brake	29	3256-23	4	Washer-5/16 SAE
10	323-11	1	Screw-HH 3/8-16 X 2 1/4	30	119-1415	4	Pin-Cotter, Locking
11	104-8301	1	Nut-Nyloc 3/8-16 Flg	31	3296-6	1	Nut-Nyloc 3/8-24
12	126-6199	4	Bushing	32	126-7587	2	Rear Linkage ASM
13	3256-24	6	Washer-3/8 SAE	32:1	126-7588	2	Yoke
14	135-7800	1	Shaft-Cross	32:2	116-9069	1	Linkage, Rear
15	135-7805	1	ASM, Front Linkage	32:3	3220-1	1	Nut-Jam 1/4-28
15:2	94-7572	1	End-Tie Rod, RH	33	32120-19	2	E-Ring
15:3	3220-3	1	Nut-Jam 3/8-24	34	3230-2	2	Bolt-Carriage 5/16-18 X 1
16	142-6328	2	Mid-Link, Short	36	116-1399	2	Locknut
17	126-4251	2	Bellcrank	37	126-6395	4	Pin-Clevis, Spring
18	126-3715	1	Arm-Inner, LH	38	126-6200	2	Spacer
				39	142-2701	2	Wheel Hub ASM
				39:2	116-1696	4	Stud-Wheel

# Fuel System Assembly

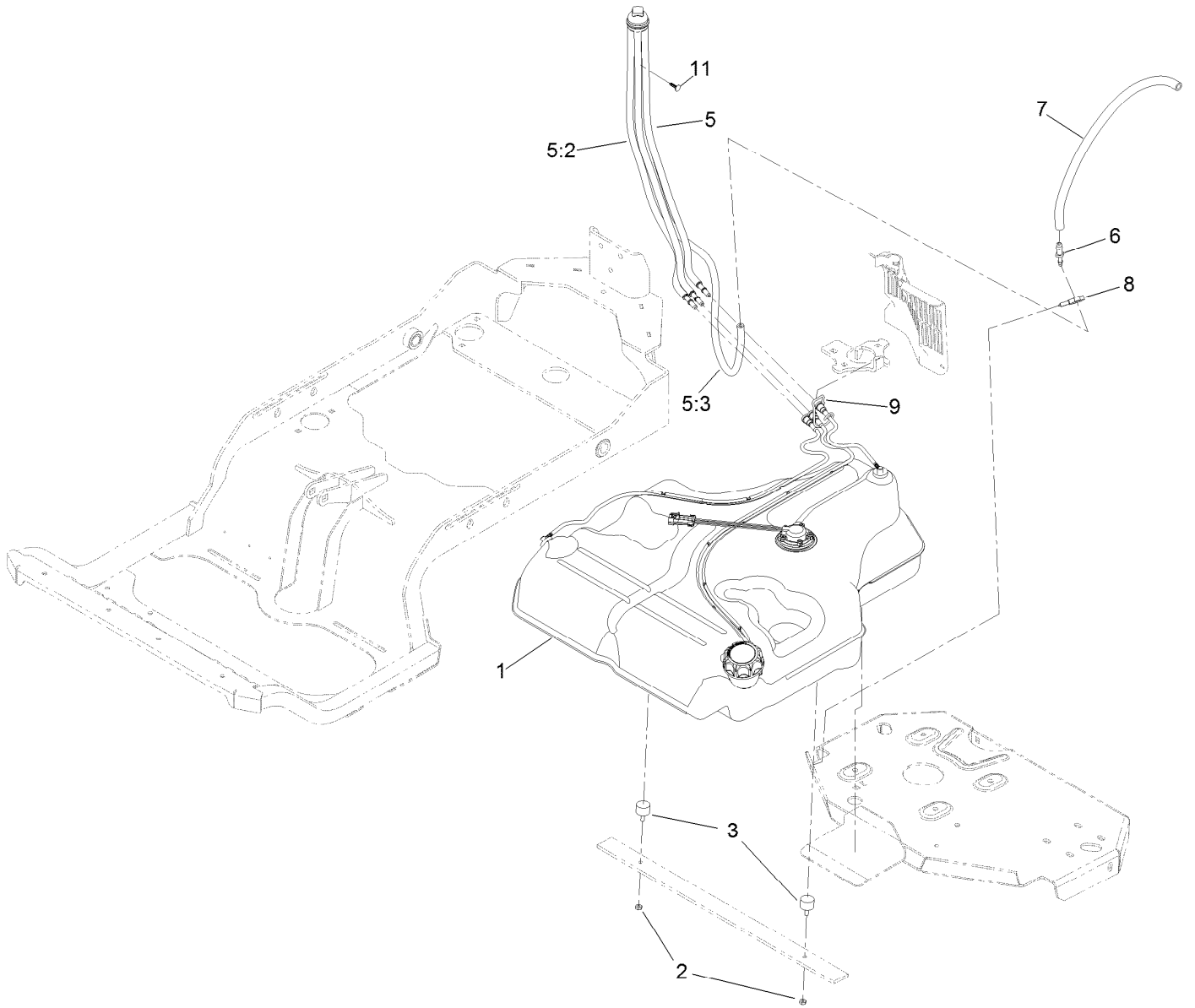



## Fuel System Assembly (continued)

<i>Ref.</i>	<i>Part Number</i>	<i>Qty.</i>	<i>Description</i>	<i>Ref.</i>	<i>Part Number</i>	<i>Qty.</i>	<i>Description</i>
1	135-0643	1	Fuel Tank ASM	6	116-5072	1	Fitting-Straight
2	3218-1	2	Nut-Jam	7	116-5087	1	Hose-Fuel
3	1-523420	2	Bumper	8	105-1853	1	Clamp-Hose
5	127-0583	1	Fuel Manifold Vent ASM	9	116-6005	1	Retainer-Line, Vapor
5:2	109-0302	3	Hose-Fuel	11	125-8067	1	Plug-Plastic
5:3	108-5376	1	Hose-Fuel				

# Fuel Tank Assembly No. 135-0643

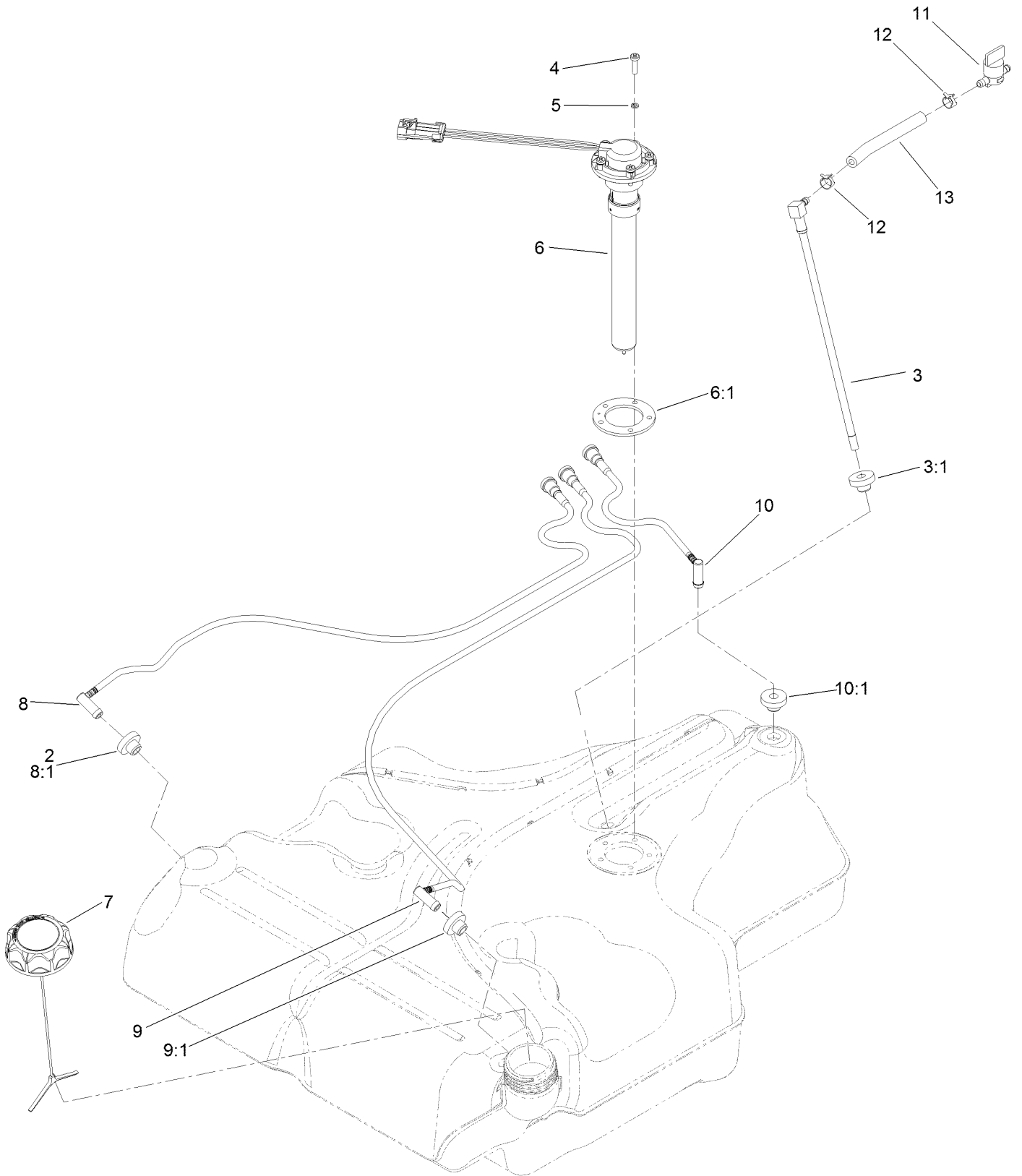

## Fuel Tank Assembly No. 135-0643 (continued)

<i>Ref.</i>	<i>Part Number</i>	<i>Qty.</i>	<i>Description</i>	<i>Ref.</i>	<i>Part Number</i>	<i>Qty.</i>	<i>Description</i>
2	46-6560	4	Bushing	8:1	46-6560	1	Bushing
3	116-2459	1	Fuel Line Kit (With Grommet)	9	116-2461	1	LH Vent Line Kit (With Grommet)
3:1	46-6560	1	Bushing	9:1	46-6560	1	Bushing
4	3290-500	5	Screw-PPH	10	116-2462	1	Rear Vent Line Kit (With Grommet)
5	3253-17	5	Washer-Lock	10:1	46-6560	1	Bushing
6	126-3913	1	Float-Sender, Fuel	11	1-603770	1	Valve-Fuel
6:1	126-3950	1	Gasket-Sender	12	2412-98	2	Clamp-Hose
7	126-1789	1	Cap-Fuel, Ratcheting	13	109-0650	1	Hose-Fuel
8	116-2460	1	RH Vent Line Kit (With Grommet)				

# Seat Mounting Assembly

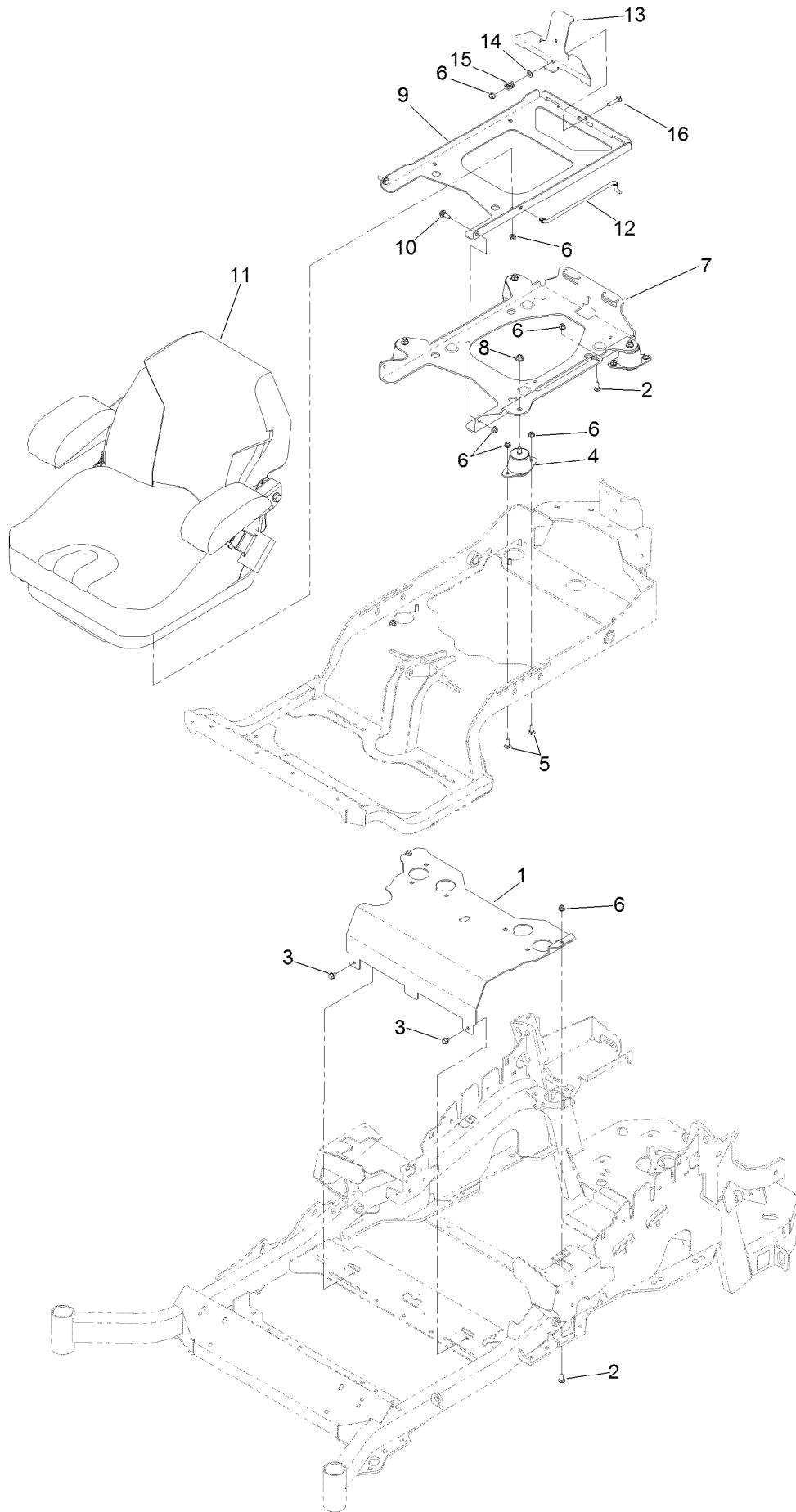

## Seat Mounting Assembly (continued)

<i>Ref.</i>	<i>Part Number</i>	<i>Qty.</i>	<i>Description</i>	<i>Ref.</i>	<i>Part Number</i>	<i>Qty.</i>	<i>Description</i>
1	116-2130-03	1	Panel-Front, Seat Mount	9	116-3859-03	1	Plate-Frame, Seat
2	3230-23	3	Bolt-CARR	10	116-1297	2	Screw-Shoulder
3	9266934	2	Screw	11	139-3641	1	Seat-Standard
4	109-9034	4	Isolator-Seat	12	116-0070	1	Rod-Prop
5	3230-10	8	Bolt-CARR	13	132-5088-03	1	Plate-Latch, Seat
6	104-8300	18	Nut-HF, NI	14	3256-23	1	Washer-Plain
7	131-6324-03	1	Plate-Support, ISO Seat	15	107-3017	1	Spring-Compression
8	104-8301	4	Nut-HF, NI	16	3230-4	1	Bolt-CARR

# Seat Assembly No. 139-3641

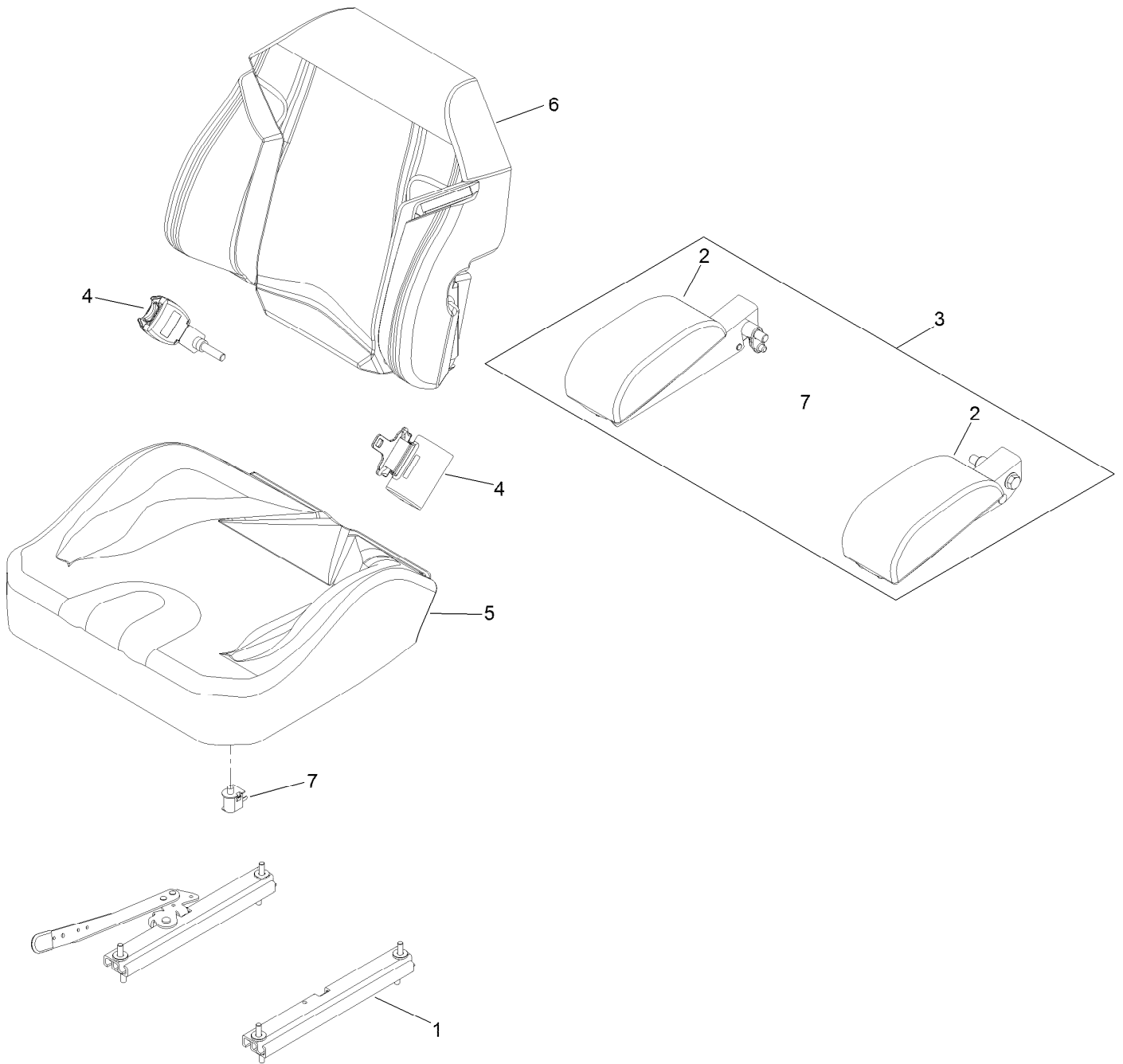

## Seat Assembly No. 139-3641 (continued)

<i>Ref.</i>	<i>Part Number</i>	<i>Qty.</i>	<i>Description</i>	<i>Ref.</i>	<i>Part Number</i>	<i>Qty.</i>	<i>Description</i>
1	109-9801	1	Seat Track Set	5	140-8006	1	Cover-Cushion
2	109-9802	1	Arm Rest Pad Set	6	140-8004	1	Cover-Back
3	109-9803	1	Arm Rest Set	7	82-2190	1	Switch-Bail
4	109-9805	1	Seat Belt Kit				

# Motion Controls Assembly

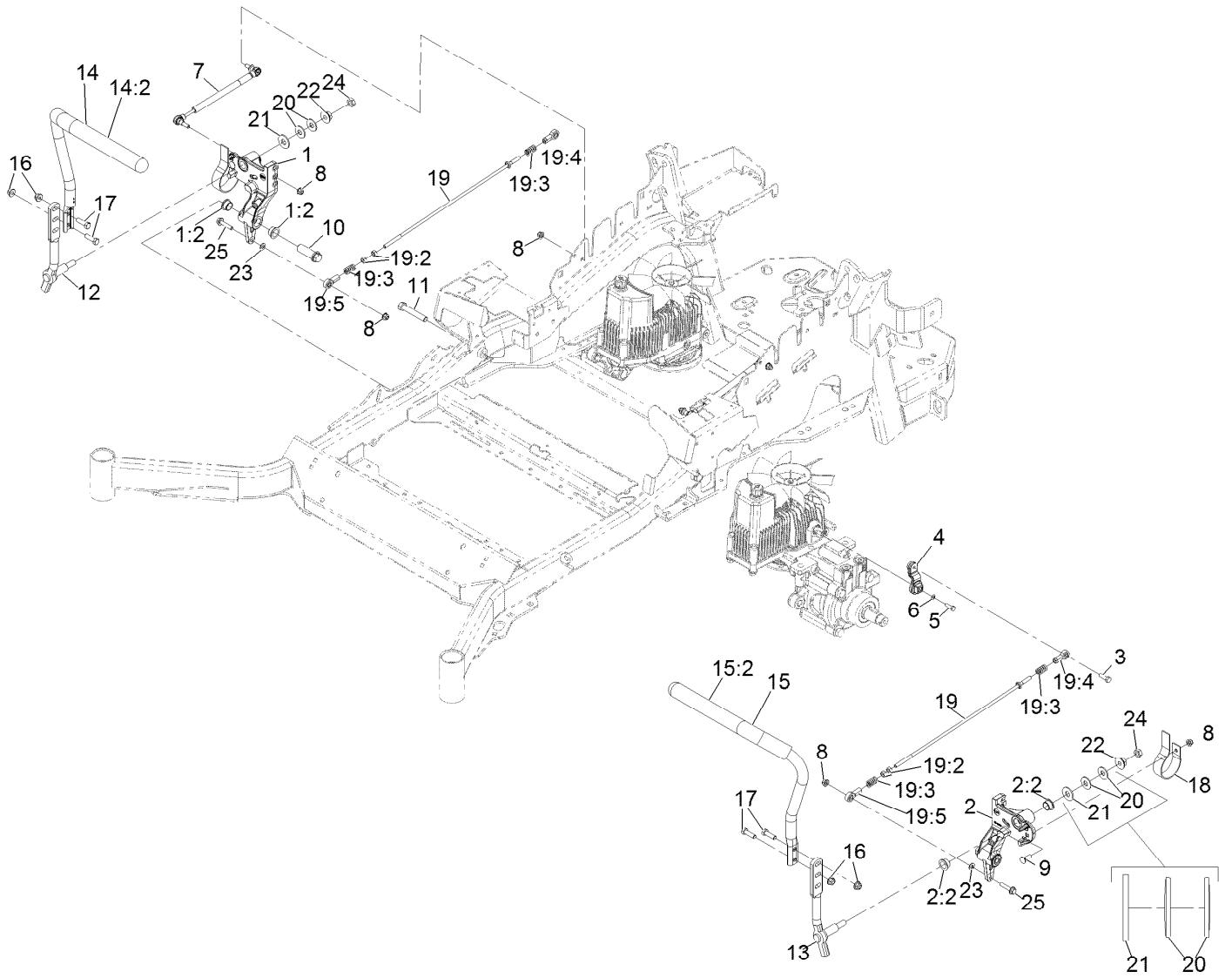



## Motion Controls Assembly (continued)

<i>Ref.</i>	<i>Part Number</i>	<i>Qty.</i>	<i>Description</i>	<i>Ref.</i>	<i>Part Number</i>	<i>Qty.</i>	<i>Description</i>
1	116-0880	1	RH Motion Control And Bushing ASM	14:2	109-5668	1	Grip-Lever, Control
1:2	109-8054	4	Bushing-Flanged	15	135-4476	1	ASM-Handle-LH
2	116-0881	1	LH Motion Control And Bushing ASM	15:2	109-5668	1	Grip-Lever, Control
2:2	109-8054	4	Bushing-Flanged	16	104-8301	4	Nut-Nyloc 3/8-16 Flg
3	116-0648	2	Screw-HH 5/16-18 X 1 W/Patch ●	17	323-7	4	Screw-HH 3/8-16 X 1 1/4
4	109-4581	2	Arm-Control, Pump	18	109-5575	2	Spring-Leaf
5	9080046	2	Screw-HH 1/4-20 X 7/8 ●	19	109-8106	2	Front Pump Linkage ASM
6	1-303435	2	Washer-Spring Disc 1/4	19:2	3219-2	2	Nut-Hex 5/16-24
7	116-0027	2	Damper-Control, Motion	19:3	1-323245	2	Spring-Compression
8	104-8300	8	Nut-Nyloc 5/16-18 Flg	19:4	1-633152	1	Balljoint
9	3230-2	2	Bolt-Carriage 5/16-18 X 1	19:5	1-543017	1	Balljoint
10	109-5891	2	Hub-Threaded	20	109-9505	4	Washer, Spring Disc 1/2
11	325-12	2	Screw-HH 1/2-13 X 3	21	3256-6	2	Washer
12	116-0039	1	Lever-Control Motion, RH	22	32128-56	2	Nut-Hex 1/2-13 Flange
13	116-0040	1	Lever-Control Motion, LH	23	3256-23	2	Washer-5/16 SAE
14	135-4727	1	Handle- RH W/Grip	24	3218-5	2	Nut-Jam 1/2-13
				25	115-1794	2	Screw-Hex Flange 5/16-18 X 1 1/2

● Use Pro-Lock, Nut Type (P/N 1-840022, .5ml tube) on threads.

# Console Assembly

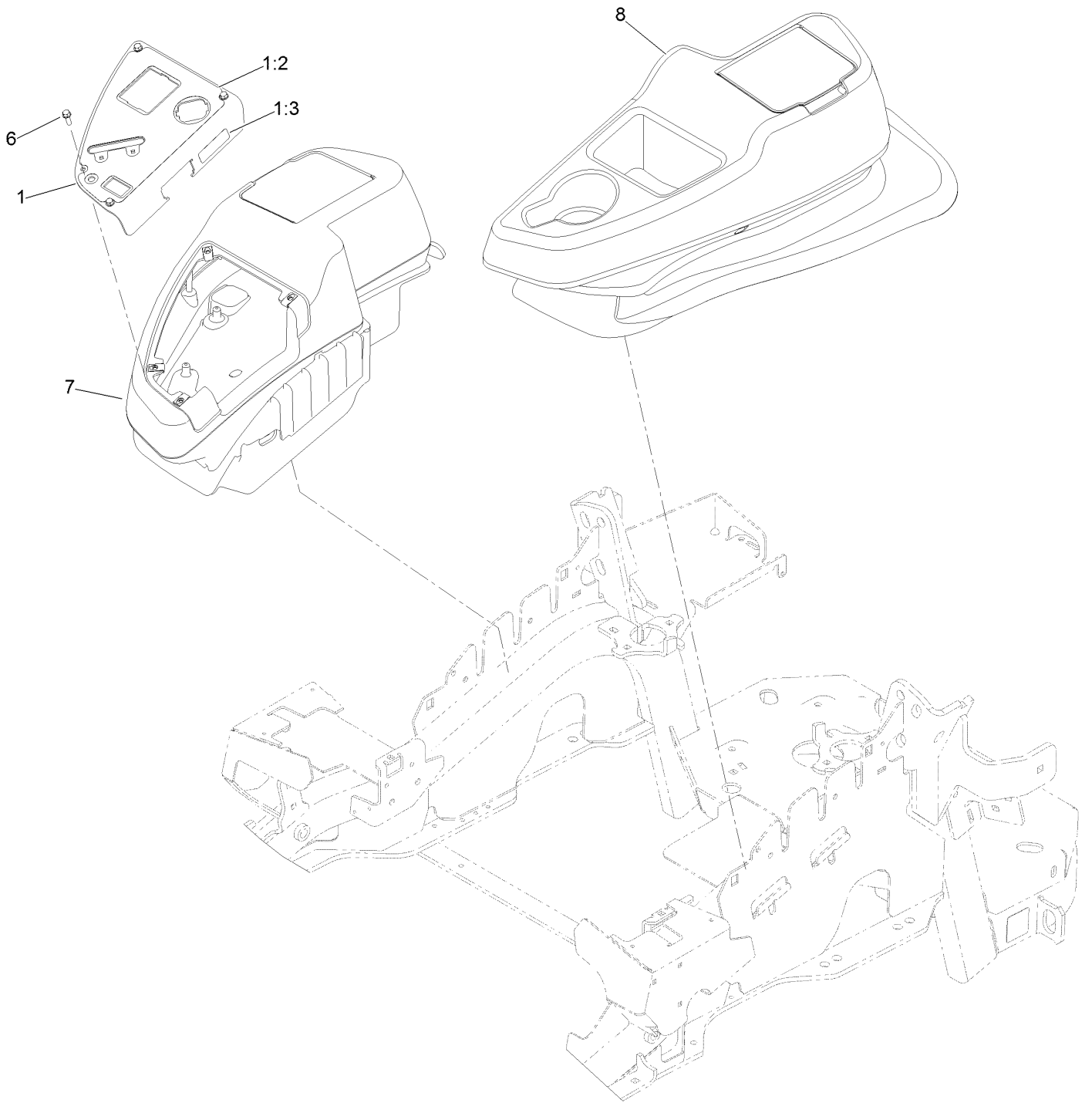

## Console Assembly (continued)

<i>Ref.</i>	<i>Part Number</i>	<i>Qty.</i>	<i>Description</i>	<i>Ref.</i>	<i>Part Number</i>	<i>Qty.</i>	<i>Description</i>
1	114-9836	1	Control Panel ASM	6	32105-15	4	Screw-HWH
1:2	120-5897	1	Decal-Panel, Control	7	115-7400	1	RH Console ASM
1:3	114-4466	1	Decal-Fuses	8	115-7401	1	LH Console ASM

# RH Console Assembly No. 115-7400

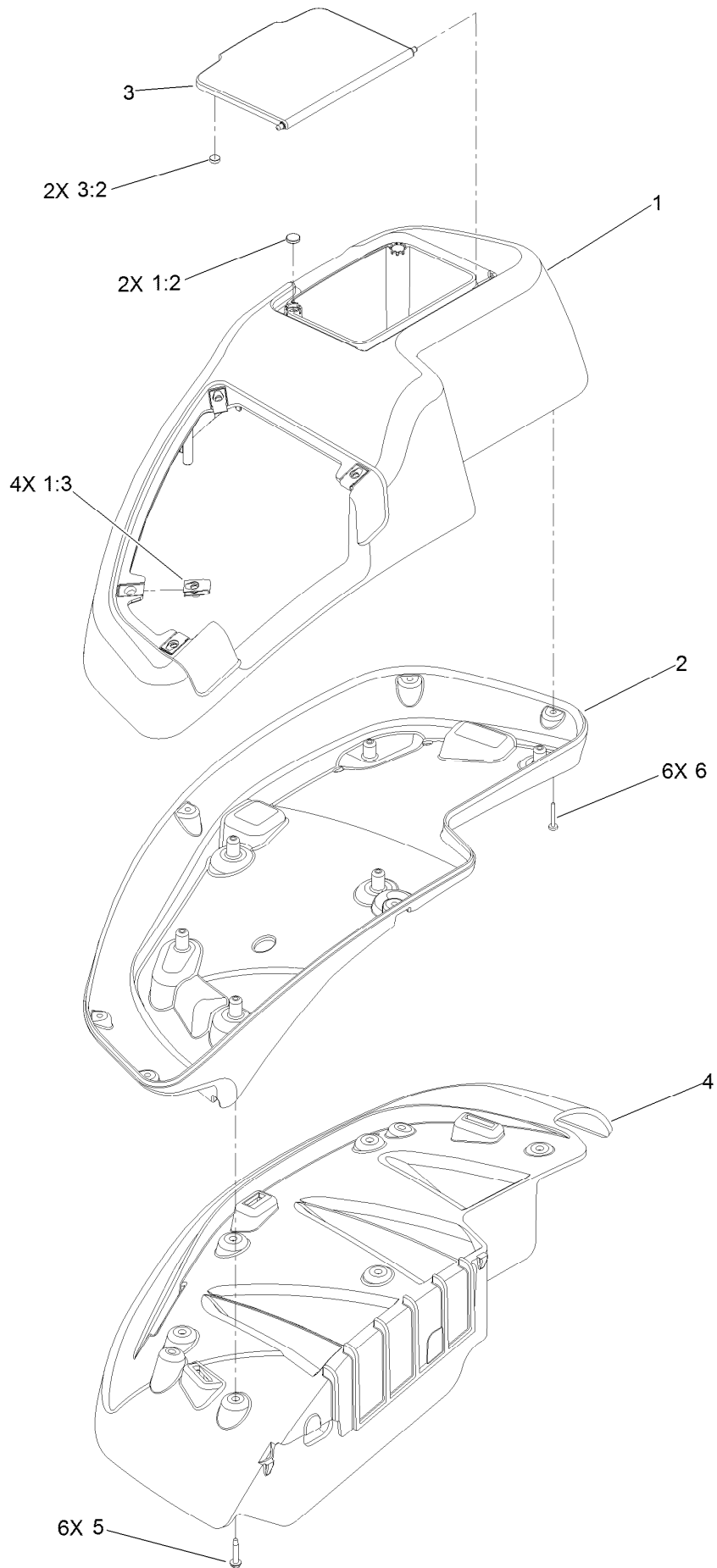

# RH Console Assembly No. 115-7400 (continued)

<i>Ref.</i>	<i>Part Number</i>	<i>Qty.</i>	<i>Description</i>	<i>Ref.</i>	<i>Part Number</i>	<i>Qty.</i>	<i>Description</i>
1	114-1538	1	RH Wide Top Console ASM	3:2	114-5896	2	Magnet
1:2	117-0883	2	Puck	4	109-9083	1	Fender-Wide, RH
1:3	107069	4	Clip	5	32144-89	6	Screw-Thread Forming
2	115-3643	1	Console-Lower, RH Wide	6	117-0347	6	Screw-PPH
3	114-1537	1	Wide Lid ASM				

# LH Console Assembly No. 115-7401

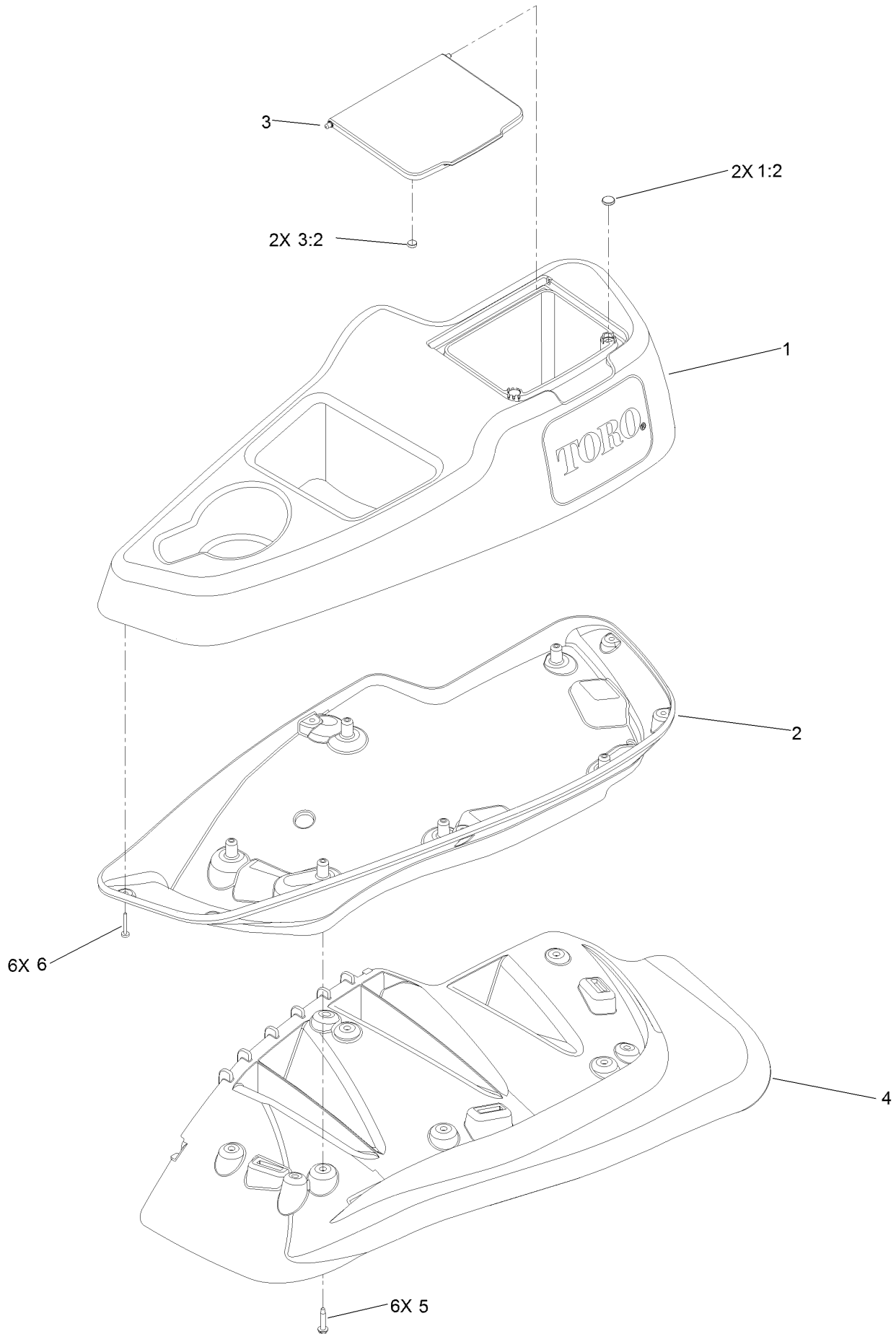

# LH Console Assembly No. 115-7401 (continued)

<i>Ref.</i>	<i>Part Number</i>	<i>Qty.</i>	<i>Description</i>	<i>Ref.</i>	<i>Part Number</i>	<i>Qty.</i>	<i>Description</i>
1	114-1539	1	LH Wide Console Top ASM	3:2	114-5896	2	Magnet
1:2	117-0883	2	Puck	4	109-9085	1	Fender-Wide, LH
2	115-3641	1	Console-Lower, LH Wide	5	32144-89	6	Screw-Thread Forming
3	114-1537	1	Wide Lid ASM	6	117-0347	6	Screw-PPH

# Electrical Assembly

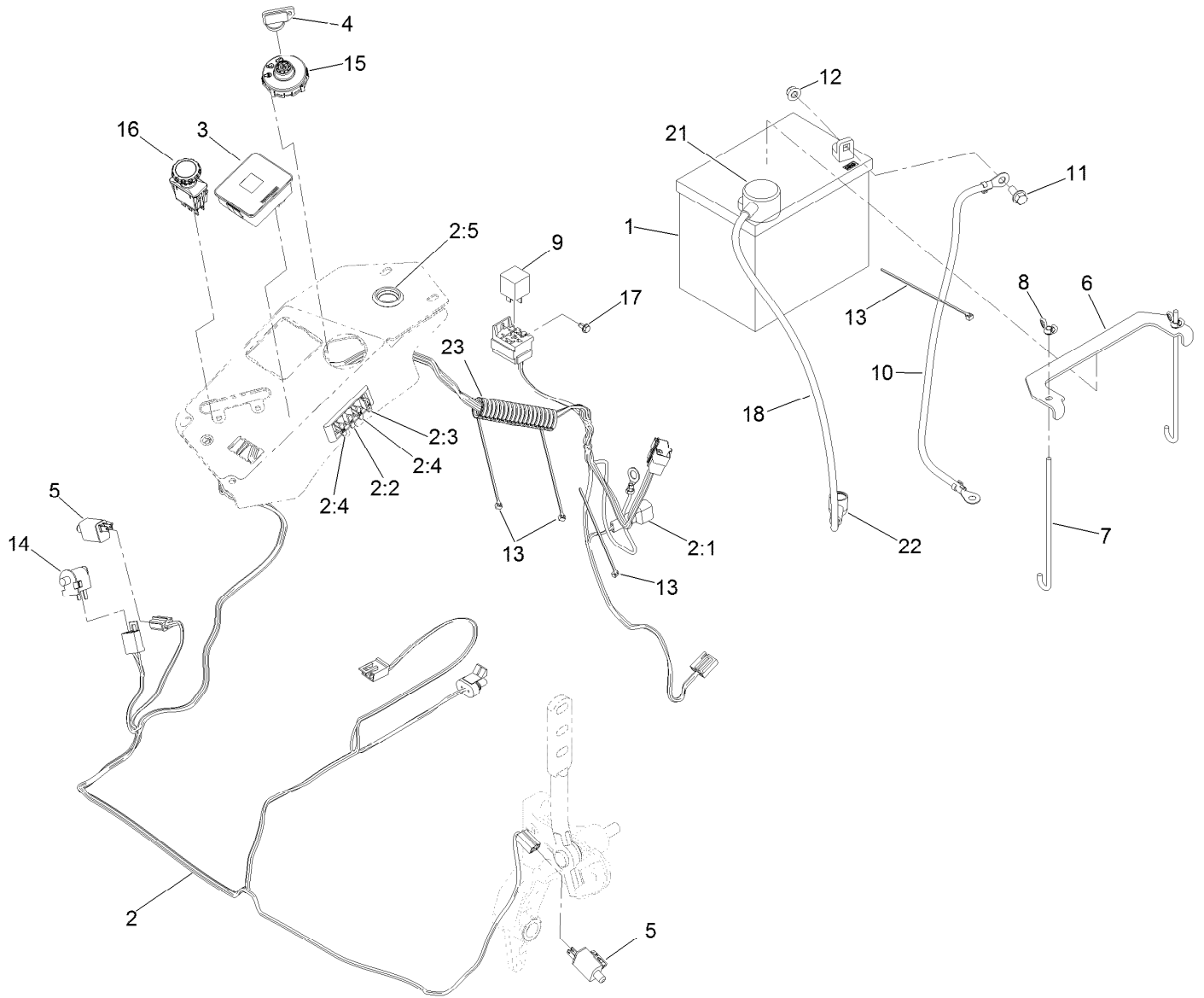



## Electrical Assembly (continued)

<i>Ref.</i>	<i>Part Number</i>	<i>Qty.</i>	<i>Description</i>	<i>Ref.</i>	<i>Part Number</i>	<i>Qty.</i>	<i>Description</i>
1	104-8162	1	Battery	9	1-643275	1	Relay
2	116-6009	1	Harness-Wire, Main ●	10	114-1218	1	Cable-Battery, Negative
2:1	103-3895	1	Diode	11	3234-5	2	Screw-HHF
2:2	218-578	1	Fuse-Blade, 10 Amp	12	104-8300	2	Nut-HF, NI
2:3	109355	1	Fuse-Blade, 15 Amp	13	1-303287	4	Tie-Cable
2:4	109102	2	Fuse-Blade, 25 Amp	14	82-2190	1	Switch-Bail
2:5	116-0053	1	Cap-Plug	15	137-4100	1	Switch-Ignition
3	117-3882	1	Fuel/Hour Meter ASM	16	135-3653	1	Switch, PTO 10A
4	1-603511	1	Keys-Ignition (Spare Pair)	17	104-2065	1	Screw-HWH
4	63-8360	1	Key-Ignition	18	115-3864	1	Cable-Battery, Positive
5	110-6765	2	Switch	21	109-2407	1	Insulator-Battery
6	116-0042-03	1	Strap-Tie Down, Battery	22	1-543393	1	Insulator-Solenoid
7	1-633651	2	Bolt-Holddown	23	131-8846	1	Cover-Hose
8	1-543792	2	Wingnut				

● Use dielectric grease on all unsealed connectors and terminals only. Do not apply in sealed connectors.

# Deck Lift Assembly

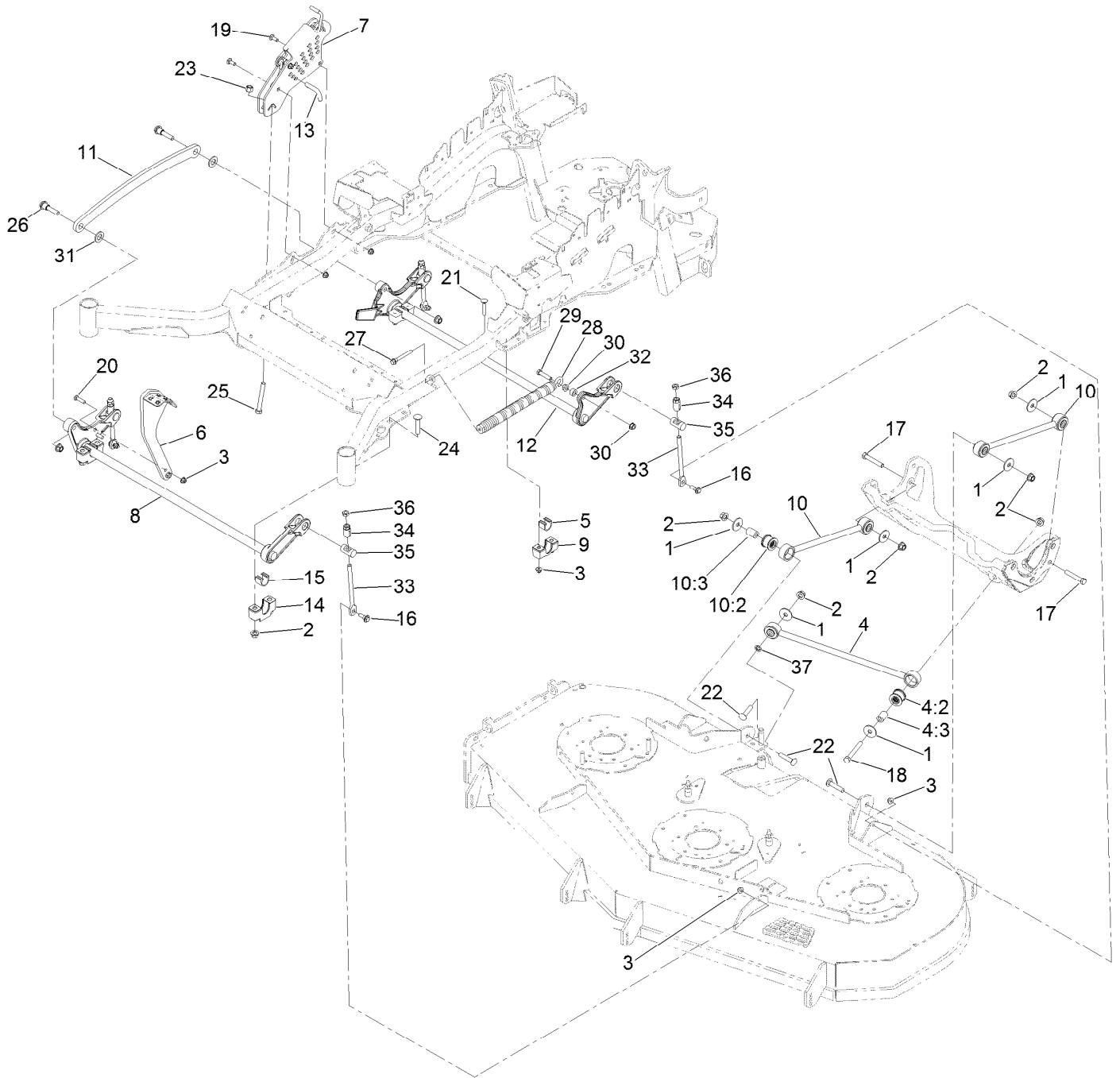

## Deck Lift Assembly (continued)

<i>Ref.</i>	<i>Part Number</i>	<i>Qty.</i>	<i>Description</i>	<i>Ref.</i>	<i>Part Number</i>	<i>Qty.</i>	<i>Description</i>
1	86-1990	6	Washer-Thrust	16	109-9840	4	Screw-Shoulder, HHF
2	99-5107	12	Nut-Lock	17	325-12	2	Screw-HH
3	104-8301	12	Nut-HF, NI	18	325-17	1	Screw-HH
4	109-5013	1	Panhard Rod ASM	19	3231-2	2	Bolt-CARR
4:2	109-5009	2	Bushing-Suspension, Rubber	20	3231-4	2	Screw-CARR
4:3	109-5010	2	Spacer	21	3231-7	4	Screw-CARR
5	109-7173	2	Bearing-Cross Shaft, Rear	22	3233-34	3	Screw-CARR
6	131-8812-01	1	Lever-Foot	23	3296-23	1	Nut-Lock, NI
7	109-7438	1	HOC ASM	24	116-1700	4	Bolt-CARR
8	126-2477-03	1	Decklift-Front	25	116-0559	1	Bolt-TAP
9	127-0553	2	Support-Bearing, Cross Shaft (Rear)	26	116-2022	2	Screw-HHF, Shoulder
10	109-7952	2	Deck Strut ASM	27	92-7674	1	Bolt-Shoulder
10:2	109-5009	2	Bushing-Suspension, Rubber	28	116-0000	1	Spring-Extension
10:3	109-5010	2	Spacer	29	109-9065	1	Screw-HH
11	116-0797-03	1	Link-Lift, Deck	30	32128-37	2	Nut-HF
12	116-2645-03	1	Lift-Deck, Rear	31	3256-28	2	Washer-Flat
13	116-5584	1	Pin-HOC	32	116-2695	1	Spacer
14	109-9409	2	Support-Bearing, Cross Shaft (Front)	33	109-8007	4	Link-Adjuster, Deck Lift
15	109-9410	2	Bearing-Cross Shaft, Front	34	109-7840	4	Adjuster-Lift, Deck
				35	109-8353	4	Trunnion
				36	3218-5	4	Nut-Jam
				37	126-2916	1	Nut-Push

# Height-of-Cut Assembly No. 109-7438



# Height-of-Cut Assembly No. 109-7438 (continued)

<i>Ref.</i>	<i>Part Number</i>	<i>Qty.</i>	<i>Description</i>	<i>Ref.</i>	<i>Part Number</i>	<i>Qty.</i>	<i>Description</i>
1	62-1330	1	Bolt-Shoulder	6	116-0118	1	Pawl-Transport, HOC
2	109-7130	1	Grommet	7	109-7335	1	HOC Plate ASM
3	104-8301	1	Nut-HF, NI	7:2	126-4398	1	Decal-HOC
4	109-7124	1	Spring-Extension	8	109-8250	1	Grip-Lever
5	109-7128	1	Rod-Lock, Transport				

# Engine, Clutch and Muffler Assembly

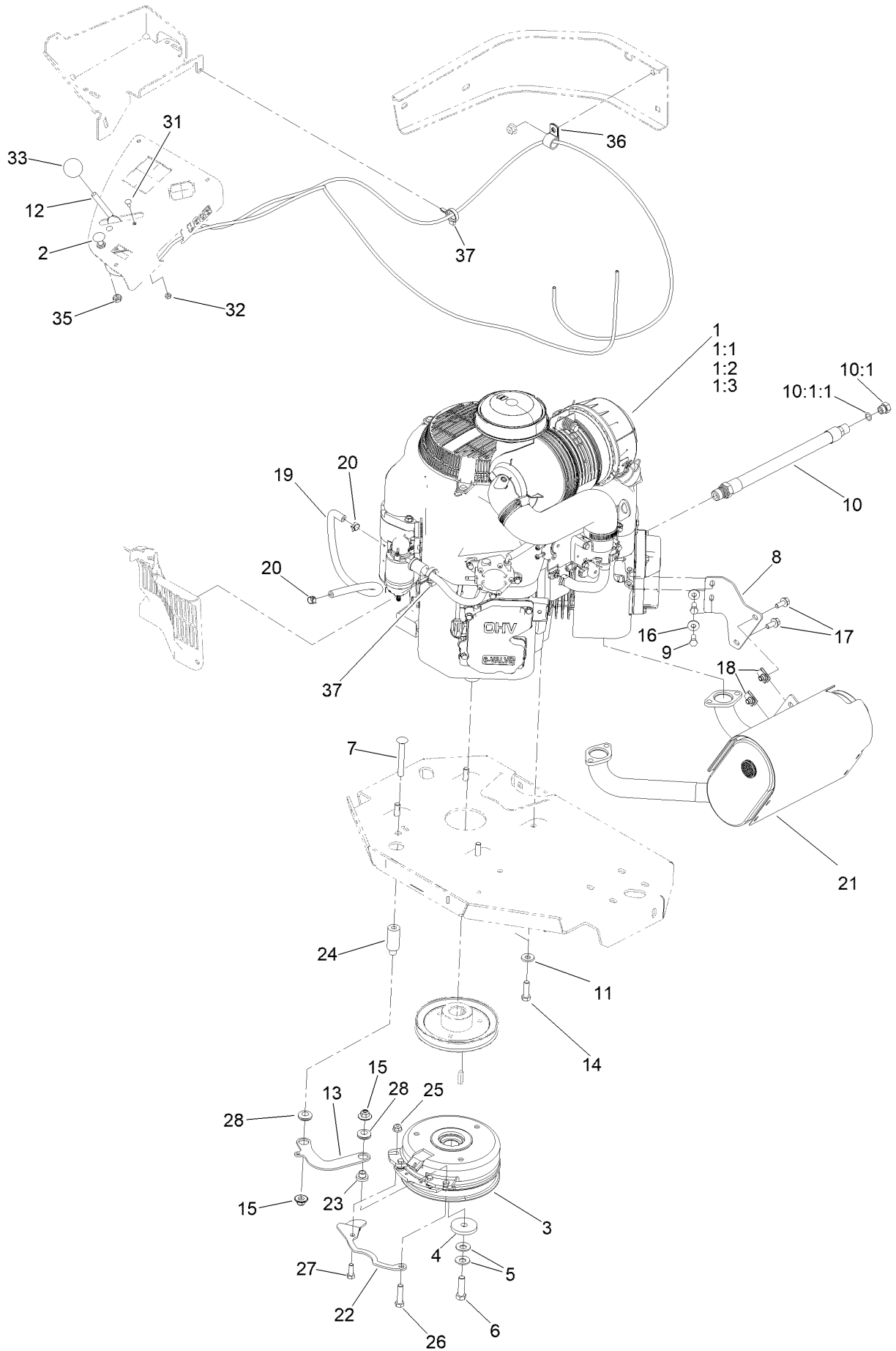

## Engine, Clutch and Muffler Assembly (continued)

<i>Ref.</i>	<i>Part Number</i>	<i>Qty.</i>	<i>Description</i>	<i>Ref.</i>	<i>Part Number</i>	<i>Qty.</i>	<i>Description</i>
1		1	Engine-Kawasaki, Fx921V-S04-R ■▲	13	116-3317-01	1	Link-Anchor, Clutch
1:1		1	Kawasaki 49065-7007 Engine Oil Filter ■▲	14	323-7	4	Screw-HH
1:2		1	Kawasaki 11013-7044 Engine Air Filter ■▲	15	109-6658	2	Nut-Flange, NI
1:3		1	Kawasaki 11013-7045 Safety Filter ■▲	16	1-303334	2	Washer-Spring
2	133-1873	1	Cable-Choke	17	3234-5	2	Screw-HHF
3	126-4185	1	Clutch Kit	18	94-2413	2	Nut-U
4	109-6919	1	Washer-Plain	19	109-0298	1	Line-Fuel
5	1-603610	2	Washer-Spring	20	2412-98	2	Clamp-Hose
6	109-9761	1	Screw-HH □	21	116-1707	1	Muffler
7	3231-42	1	Screw-CARR	22	116-3331-01	1	Belt-Guide
8	116-1587	1	Bracket-Muffler	23	116-3318	1	Spacer
9	33114-020	2	Screw-HH	24	116-3319	1	Spacer
10	116-4924	1	Engine Oil Drain Hose ASM ◆	25	104-8300	1	Nut-HF, NI
10:1	353-508	1	Plug-HH ●	26	323-8	1	Screw-HH
10:1:1	237-42	1	O-Ring	27	322-4	1	Screw-HH
11	98-5975	4	Washer-Belleville	28	93-5108	2	Grommet-Rubber
12	133-1816	1	Throttle-Control	31	1-807513	2	Bolt-CARR
				32	3296-2	2	Nut-Lock, NI
				33	1-603175	1	Knob-Ball
				35	3220-3	1	Nut-HJ
				36	1-633396	1	Clip-Loom
				37	105-1853	2	Clamp-Hose

● Torque to 24-26 ft-lb

▲ Obtain parts from [www.kawpower.com](http://www.kawpower.com)

◆ Use a Teflon Pipe Sealant or equivalent on threads.

□ Use Pro-Lock, Nut Type (P/N 1-840022, .5ml tube) on threads.

■ Not serviced separately

# Deck Assembly

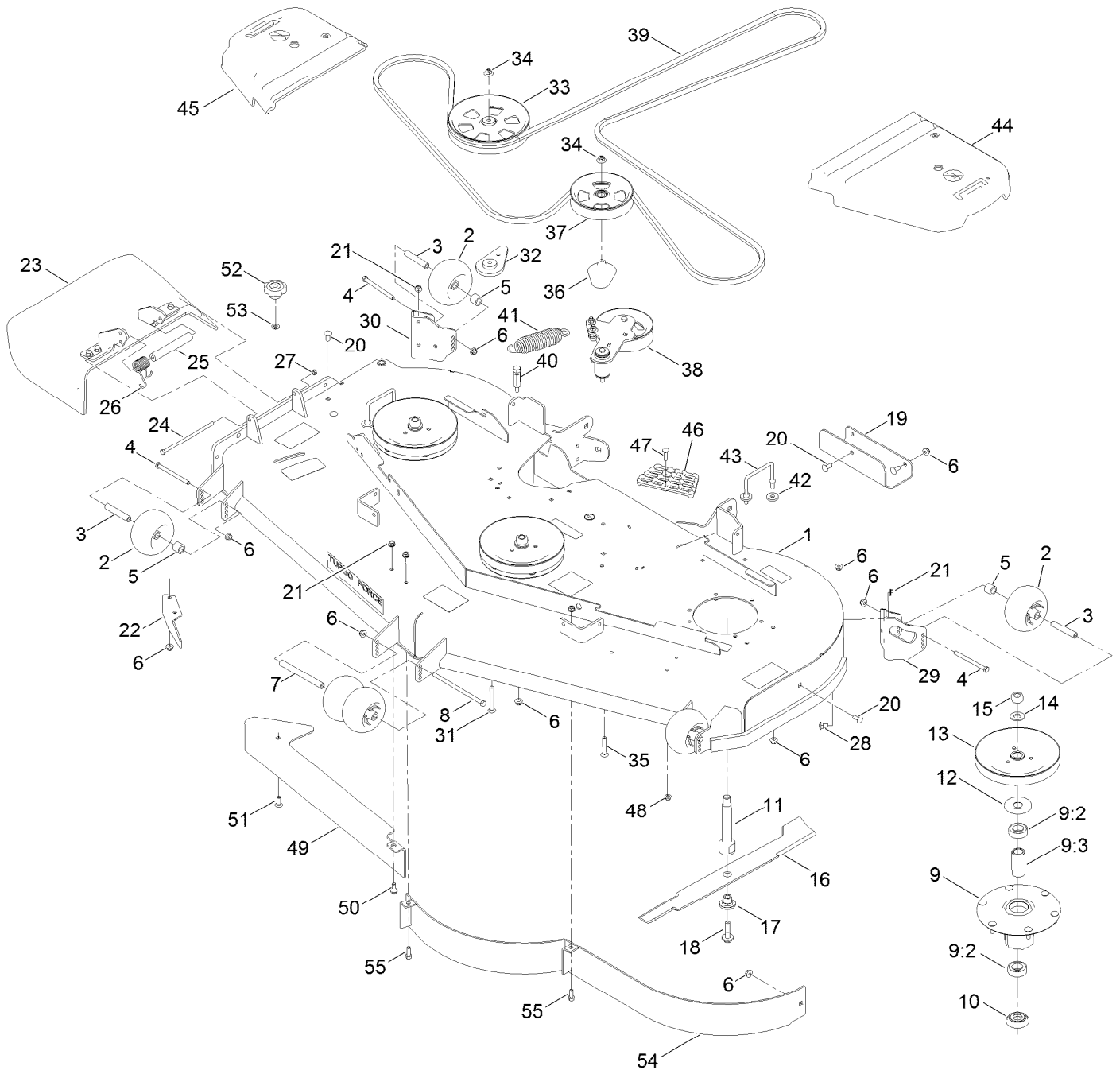



## Deck Assembly (continued)

<i>Ref.</i>	<i>Part Number</i>	<i>Qty.</i>	<i>Description</i>	<i>Ref.</i>	<i>Part Number</i>	<i>Qty.</i>	<i>Description</i>
1	140-1170	1	Deck Decal ASM	28	3231-1	6	Screw-CARR
2	1-603299	6	Roller-Scalp, Anti	29	106-7354-01	1	Mount-Wheel, LH
3	98-7912	4	Tube-Spanner	30	106-7355-01	1	Mount-Wheel, RH
4	323-23	4	Screw-HH	31	3231-42	1	Screw-CARR
5	98-7913	4	Tube-Spacer	32	109-9416	1	Spacer-Idler
6	104-8301	34	Nut-HF, NI	33	132-4734	1	Pulley-Idler, Flat
7	98-5967	1	Spacer-Wheel	34	109-6658	2	Nut-Flange, NI
8	108-5388	1	Screw-HH	35	3231-40	1	Bolt-CARR
9	137-9780	3	Spindle ASM	36	109-2872	1	Spacer-Pulley
9:2	116-0720	2	Bearing-Ball	37	136-5404	1	Pulley-Idler, Flat
9:3	138-6042	1	Spacer-Bearing	38		1	Idler Arm ASM ●
10	137-9784	3	Guard-Bottom	39	109-9023	1	Belt-V
11	138-6045	3	Shaft-Spindle	40	114-5867	1	Anchor-Spring, Tall
12	103-1330	3	Guard-Bearing, Top	41	116-6317	1	Spring-Extension
13	138-6060	3	Sheave-Drive, Blade	42	1-373034	4	Washer
14	103-2802	3	Washer	43	109-6982	2	Wireform-Cover
15	116-7306	3	Nut-Hex	44	109-6938	1	Cover-Belt, LH
16	140-1238	3	Blade	45	116-0094	1	Cover-Belt, RH
17	137-9787	3	Bushing-Hex	46	126-4781-03	1	Step-Deck
18	109-9220	3	Screw-Sems	47	3230-3	1	Screw-CARR
19	121-7975-01	1	Plate-Skid	48	104-8300	1	Nut-HF, NI
20	3231-27	6	Screw-CARR	49	138-6051-01	1	Plate-Baffle
21	3290-357	9	Nut-HSF	50	94-7582	1	Bolt-Shoulder
22	106-3216-01	1	Baffle-Discharge	51	3231-22	1	Screw-CARR
23	108-2792	1	Rubber Deflector ASM	52	109-1092	1	Knob
24	322-50	1	Screw-HH	53	100-4852	1	Washer-Hardened
25	105-4622	1	Spacer	54	114-5843-01	1	Baffle
26	108-4052	1	Spring-Torsion	55	92-1624	2	Screw-HWH Thd Form
27	3296-47	1	Nut-Lock, NI				

● Not serviced separately

# Deck Decal Assembly No. 140-1170

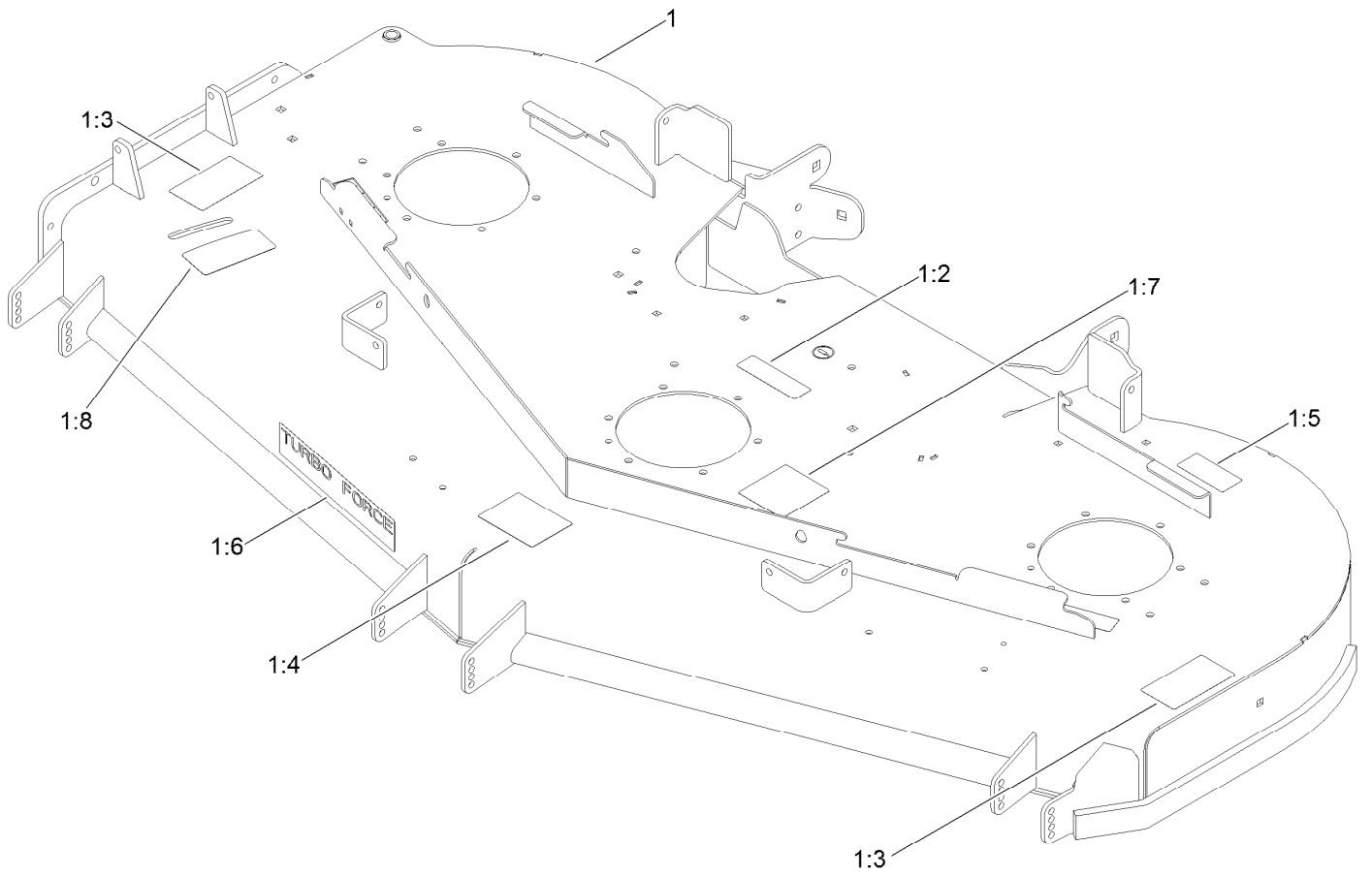

## Deck Decal Assembly No. 140-1170 (continued)

<i>Ref.</i>	<i>Part Number</i>	<i>Qty.</i>	<i>Description</i>	<i>Ref.</i>	<i>Part Number</i>	<i>Qty.</i>	<i>Description</i>
1		1	Deck ASM ●	1:5	116-8283	1	Decal-Torque, Bolt
1:2	112-9028	3	Decal-Cover, Missing	1:6	107-1620	1	Decal
1:3	117-3848	2	Decal-Danger	1:7	136-5508	1	Decal-Routing, Deck Belt
1:4	127-0326	1	Decal-Scalp, Anti	1:8	131-1180	1	Decal-Adjustment, Baffle

● Not serviced separately

# Rubber Deflector Assembly No. 108-2792

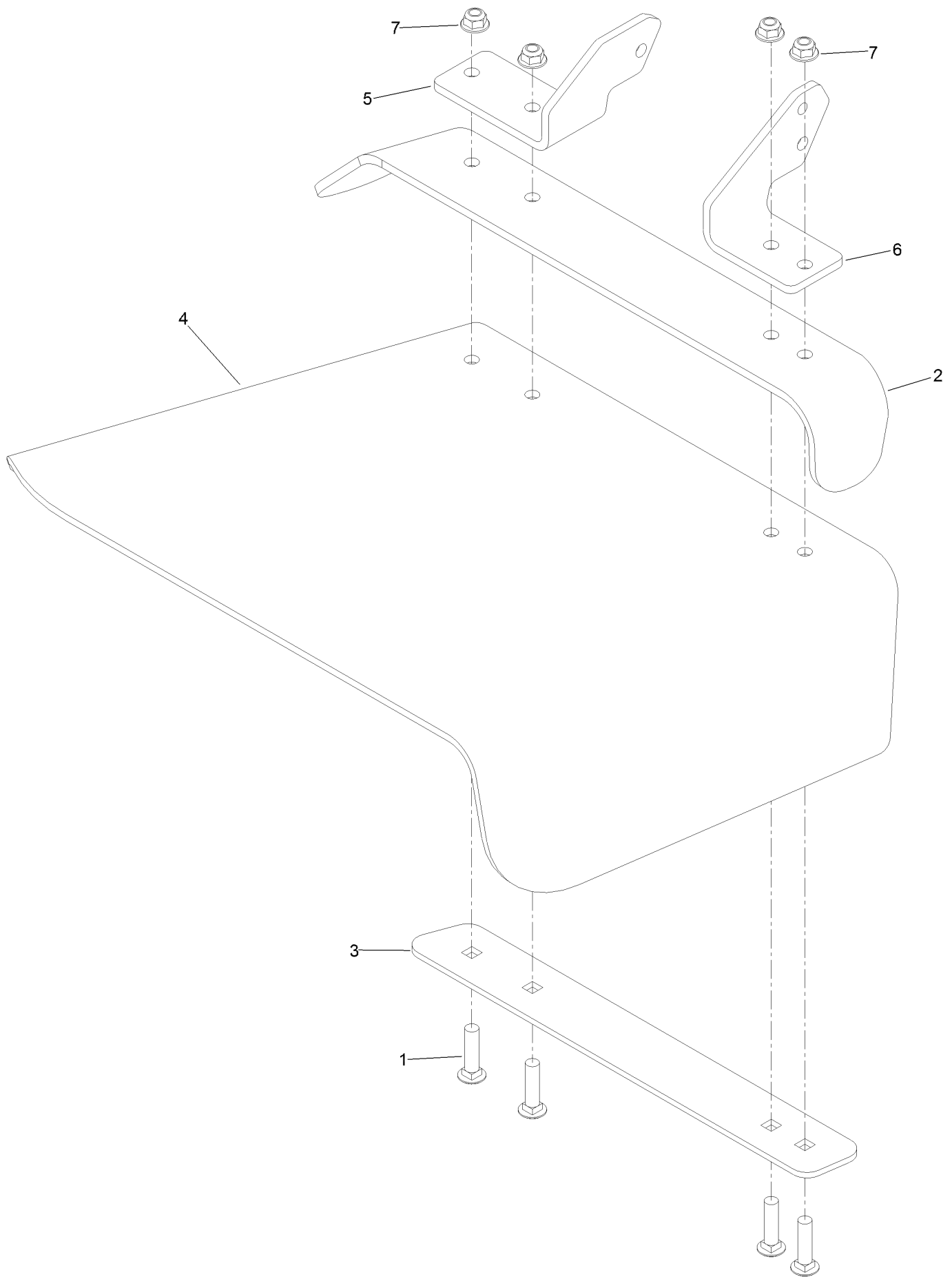

# Rubber Deflector Assembly No. 108-2792 (continued)

<i>Ref.</i>	<i>Part Number</i>	<i>Qty.</i>	<i>Description</i>	<i>Ref.</i>	<i>Part Number</i>	<i>Qty.</i>	<i>Description</i>
1	3231-4	4	Screw-CARR	5	108-4059-01	1	Plate-Hinge, Rear
2	106-3246-01	1	Deflector	6	106-3253-01	1	Plate-Hinge, Front
3	106-3248-03	1	Strap-Discharge	7	104-8301	4	Nut-HF, NI
4	108-5029	1	Deflector-Rubber				

# Idler Arm Assembly

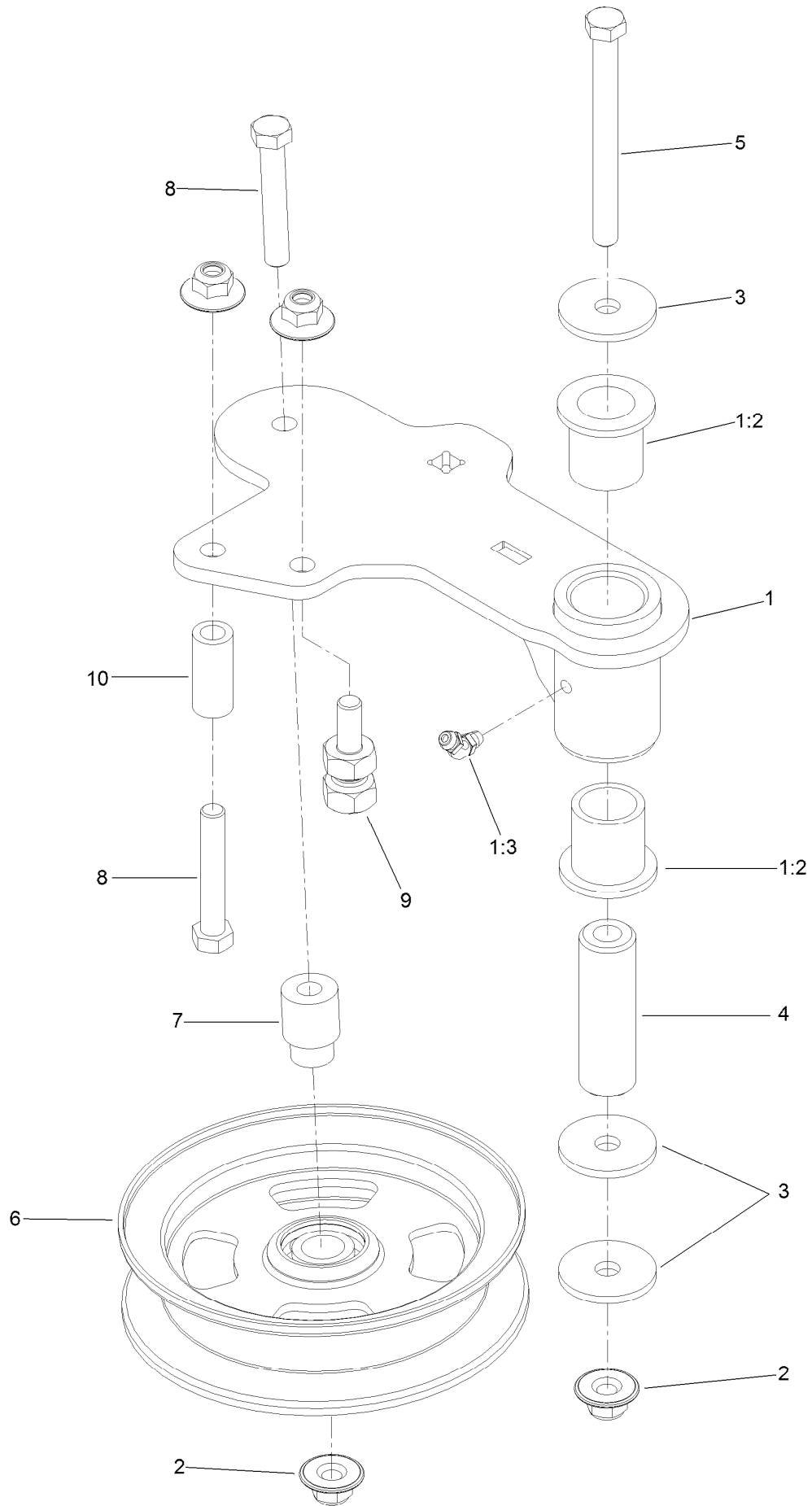

## Idler Arm Assembly (continued)

<i>Ref.</i>	<i>Part Number</i>	<i>Qty.</i>	<i>Description</i>	<i>Ref.</i>	<i>Part Number</i>	<i>Qty.</i>	<i>Description</i>
1	114-5870	1	Idler Arm ASM	5	98-5961	1	Screw-HH
1:2	1-303514	2	Bearing-Flanged	6	132-9425	1	Pulley-Idler, Flat
1:3	1481	1	Fitting-Grease	7	112-4212	1	Mount-Pulley
2	109-6658	4	Nut-Flange, NI	8	323-11	2	Screw-HH
3	1-213069	3	Washer	9	132-4729	1	Anchor-Spring, Short
4	114-5848	1	Spacer-Plain	10	104-0151	1	Spacer

# Frame Decal Assembly

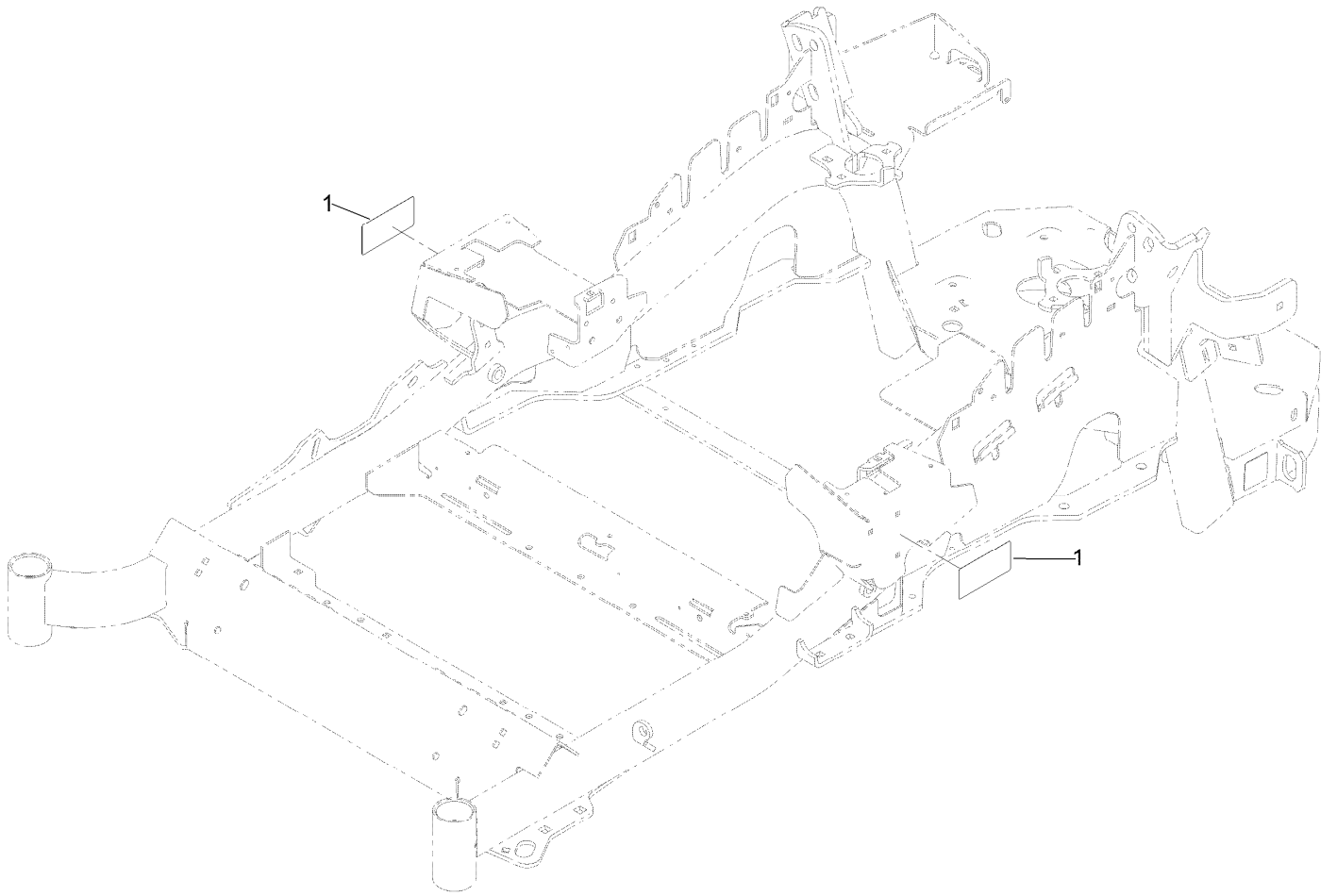



## Frame Decal Assembly (continued)

<i>Ref.</i>	<i>Part Number</i>	<i>Qty.</i>	<i>Description</i>
1	120-5895	2	Decal

# Attachments and Accessories

## For 72968 Z Master Professional 6000 Series Riding Mower with 72in TURBO FORCE Side Discharge Mower

Product Name	Model/Part
Turbo Baffle Kit .....	107-1634
Hitch Kit .....	109-9487
Hypr-Oil 500 (quart) .....	114-4713
Hypr-Oil 500 (gallon).....	114-4714
Hypr-Oil 500-5 (5 gallon).....	114-4715
Bimini Folding Shade Assembly .....	115-4510
Roller Striper Kit.....	115-7480
Light Kit.....	116-1154
Seat Cover (W/arm rest).....	117-0095
Operator Controlled Discharge Chute Kit.....	117-3600
Toro Rops Lock Kit.....	126-4064
Jack Mount Kit .....	127-6665
Jack Kit.....	127-6666
Worklight Kit .....	135-7320
Shock/Spring Asm .....	136-8993
Bucket Mount Kit.....	137-9216
Trimmer Mount .....	137-9769
Recycler Kit-G3/GM 3300 72in .....	139-6659
24x12n12 - Tweel Turf .....	139-7891
Blade-24.50 High Flow .....	140-1238
Blade-24.50 Atomic .....	140-1239
Blade-24.50 Medium Flow .....	140-4850
Blade-24.50 Low Flow .....	140-4851
Blade-24.50 Recycler .....	140-4852
6 Pack-Blade, 24.5 High Flow.....	140-4872
6 Pack-Blade, 24.5 Med Flow .....	140-4873
6 Pack-Blade, 24.5 Low Flow .....	140-4874
6 Pack-Blade, 24.5 Atomic.....	140-4875
6 Pack-Blade, 24.5 Recycler.....	140-4876
Weight Kit, Under Toe Board.....	140-4958
Toro Rider Over Seat Bag .....	490-7317
Toro Deluxe Rider Cover.....	490-7319
Toro Rider Arm Rest Bag .....	490-7320
Spark Arrestor Screen .....	75-6880
Blower and Drive Kit .....	78554
72in E-z Vac Triple Bagger .....	78555
72in E-z Vac Dfs Bagger.....	78556
Filter Minder Gauge .....	99-4664
Trash Holder Kit.....	TC26

**Notes:**



**Count on it.**