



Count on it.

Parts Catalog

Vista™

4 Passenger Lithium Shuttle Vehicle

Model No. 08924—Serial No. 415200000 and Up



Ordering Replacement Parts

To order replacement parts, please supply the part number, the quantity, and the description of each part desired.

Understanding Reference Numbers

Each identified part in an illustration has a reference number. The reference number for a part also appears in the parts list, along with other information about the part.

This catalog uses two special reference number formats, one to indicate parts in a service assembly and another to indicate the quantity of a given part in an illustration.

Service Assembly Reference Numbers

Parts in service assemblies have reference numbers in the form a:b. The a represents the reference number of the entire service assembly and the b represents a sequential number unique to each part within the service assembly.

For example, a wheel assembly might be identified by reference number 6, the tire by 6:1, the valve by 6:2, and the wheel by 6:3. When you order the assembly identified by reference number 6, you receive all parts identified by reference numbers 6:1, 6:2, and 6:3. However, you may also order any part individually. Reference numbers of this type appear in illustration and in parts lists.

Reference Numbers Indicating Quantity

In an illustration, if a reference number indicates more than one part, the reference number has the form nX y. The n represents the quantity of the part, the X is the multiplication symbol, and the y represents the reference number.

For example, in an illustration, the reference number 2X 37 means that two of the parts identified by reference number 37 are indicated.

Contents

Frame Assembly.....	4
Front Suspension Assembly.....	6
Steering Assembly.....	8
Rear Suspension Assembly.....	10
Brake and Throttle Pedal Assembly.....	12
Front and Rear Brake Assembly.....	14
Master Cylinder Assembly No. 104-6782.....	16
Brake Caliper Assembly No. 140-2575.....	17
Hood, Front Fenders and Dash Assembly.....	18
Main Seat and Rear Fenders Assembly.....	20
Rear Facing Seat Assembly.....	22
Batteries, Motor and Transaxle Assembly.....	24
Transaxle Assembly No. 145-7060.....	26
Electric Motor Assembly No. 137-6936.....	28
Dash Electrical Components Assembly.....	30
Electrical Assembly.....	32
Wire Harness Assembly No. 122-1591.....	34
Attachments and Accessories.....	36

Frame Assembly

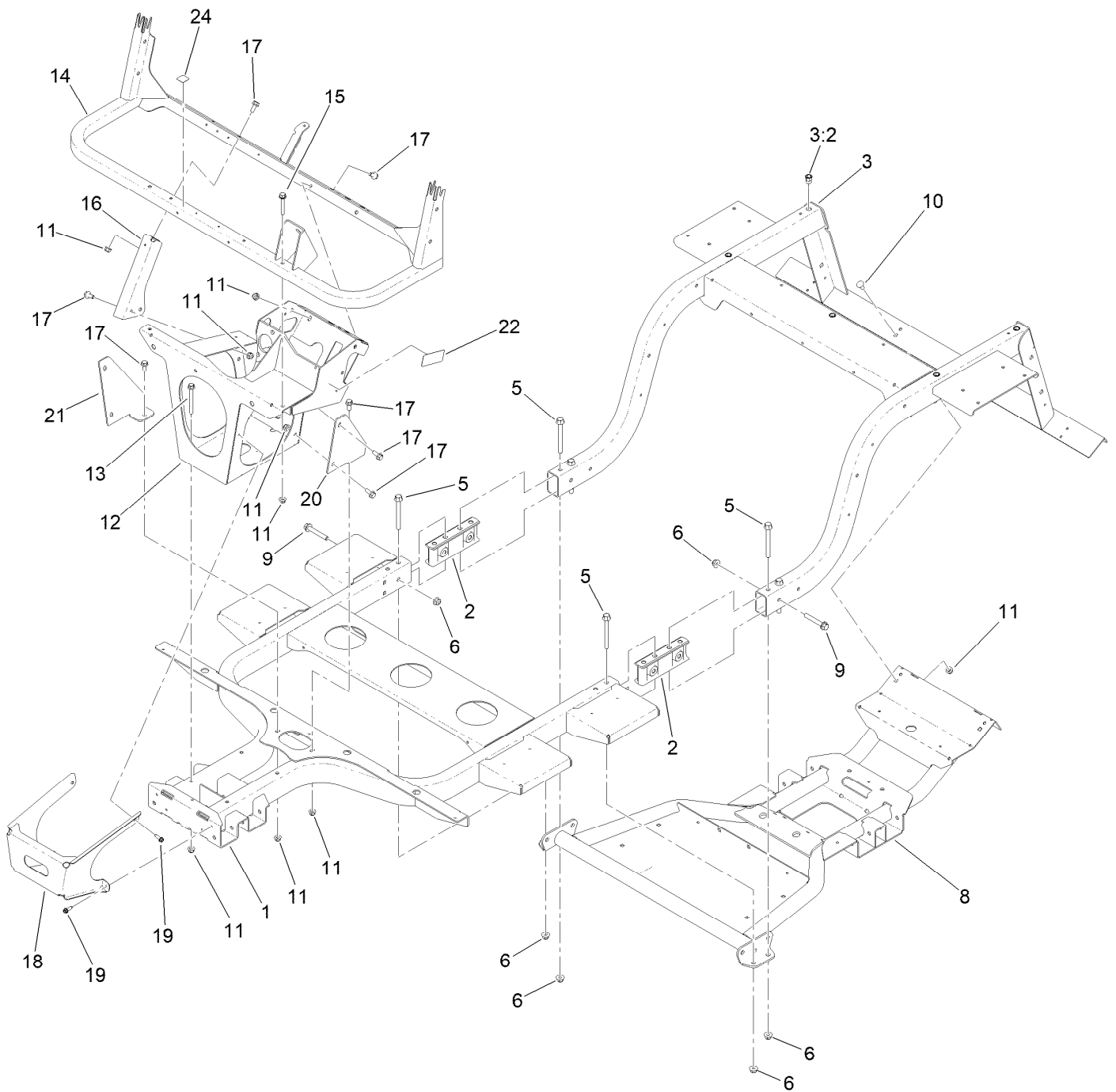

Frame Assembly (continued)

<i>Ref.</i>	<i>Part Number</i>	<i>Qty.</i>	<i>Description</i>	<i>Ref.</i>	<i>Part Number</i>	<i>Qty.</i>	<i>Description</i>
1	140-0799	1	Front Frame ASM	13	126-4687	4	Screw-HHF
2	144-5479	2	Connector-Frame	14	140-9712-03	1	Canopy Support ASM
3	144-5465	1	Rear Frame ASM	15	140-9909	2	Screw-HHF
3:2	138-2899	5	Nut-Clinch	16	161-2017-03	1	Support-Canopy
5	139-3370	8	Screw-HF	17	3234-47	11	Screw-HHF
6	139-3380	12	Nut-HF	18	140-0940-03	1	Bracket-Support, Bumper
8	140-9746	1	Battery Subframe ASM	19	49-2040	4	Screw-HWHTF
9	144-5559	4	Screw-HHF	20	145-7152-03	1	Gusset-Frame, LH
10	3230-1	2	Bolt-CARR	21	145-7153-03	1	Gusset-Frame, RH
11	104-8300	19	Nut-HF, NI	22	144-5580	1	Decal - Vista Li+ Service
12	140-0777-03	1	Shock Tower ASM	24	145-7345	1	Decal-Voltage, High

Front Suspension Assembly (continued)

<i>Ref.</i>	<i>Part Number</i>	<i>Qty.</i>	<i>Description</i>	<i>Ref.</i>	<i>Part Number</i>	<i>Qty.</i>	<i>Description</i>
1	145-7065	2	Strut ASM	3:6	93-0309	1	Washer-Tab
1:1	145-7063	1	Spring-Coil	3:7	3220-7	1	Nut-Jam
1:2	131-8574	1	Isolator-Shock	3:8	93-0307	1	Nut-Lock, Retainer
2		1	LH Spindle ASM ●	3:9	3272-12	1	Pin-Cotter
2:1	144-5468	1	Spindle ASM LH	3:10	241-119	1	Cap-Dust
2:1:2	140-4615	2	Bushing-Flange	3:11	139-4474	1	Rotor-Brake
2:4	144-5470	1	Front Hub ASM	3:12	121-9671	4	Screw-HSBH
2:4:2	10-6830	4	Stud-Type, Drive	12	140-9801	2	Tire ASM
2:4:3	254-72	2	Bearing-Cup, Tapered	12:1	131-8317	1	Wheel
2:4:4	254-94	2	Bearing-Cone, Tapered	12:2	232-27	1	Stem-Valve
2:5	112-1690	1	Seal-Oil	12:3	140-9794	1	Tire
2:6	93-0309	1	Washer-Tab	13	242-50	8	Nut-Lug
2:7	3220-7	1	Nut-Jam	14	161-1819	2	Control Arm ASM
2:8	93-0307	1	Nut-Lock, Retainer	14:3	147-3983	2	Bushing-Flange
2:9	3272-12	1	Pin-Cotter	15	144-5634	2	Sleeve-Outer
2:10	241-119	1	Cap-Dust	16	131-8582	2	Sleeve-Kingpin
2:11	139-4474	1	Rotor-Brake	17	139-3350	2	Screw-HF
2:12	121-9671	4	Screw-HSBH	18	139-3370	2	Screw-HF
3		1	RH Spindle ASM ●	19	140-9853	4	Screw-HF
3:1	144-5469	1	Spindle ASM RH	20	139-3380	8	Nut-HF
3:1:2	140-4615	2	Bushing-Flange	21	3234-46	2	Screw-HHF
3:4	144-5470	1	Front Hub ASM	22	99-5107	2	Nut-Lock
3:4:2	10-6830	4	Stud-Type, Drive	23	140-0933	2	Wheel Cover ASM
3:4:3	254-72	2	Bearing-Cup, Tapered	23:2	140-0932	3	Clip-Cover, Wheel
3:4:4	254-94	2	Bearing-Cone, Tapered	24	140-9793	4	Pin Seal
3:5	112-1690	1	Seal-Oil				

● Not serviced separately

Steering Assembly

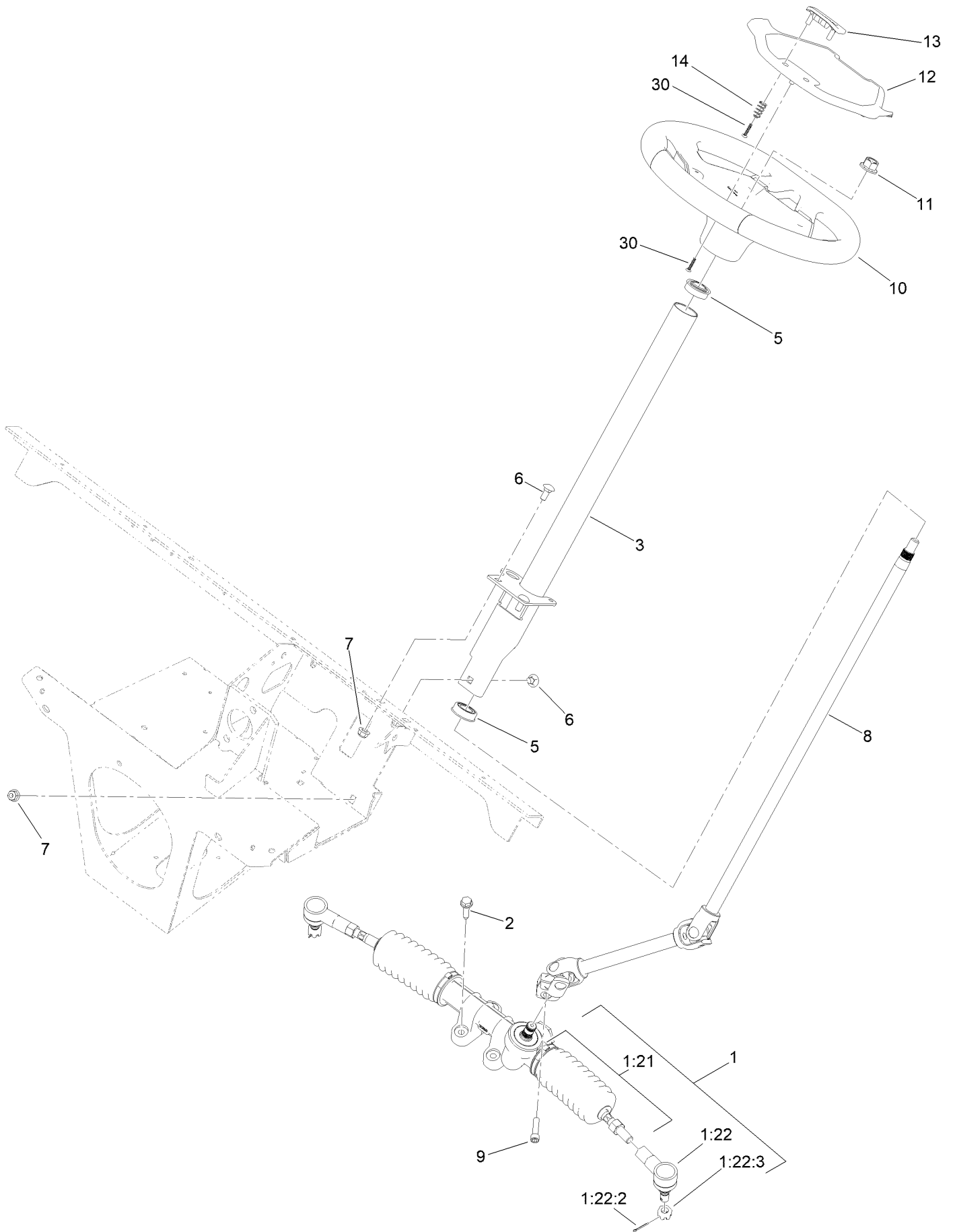

Steering Assembly (continued)

<i>Ref.</i>	<i>Part Number</i>	<i>Qty.</i>	<i>Description</i>	<i>Ref.</i>	<i>Part Number</i>	<i>Qty.</i>	<i>Description</i>
1	140-9830	1	Steering Rack ASM	7	104-8300	3	Nut-HF, NI
1:21	140-9829	1	Kit-Tie Rod ASM	8	140-9704	1	Shaft-Steering
1:22	140-4592	1	Kit-Rod End ASM	9	145-7145	1	Screw-HSH,Lock
1:22:2	3272-42	1	Pin-Cotter	10	144-5570	1	Steering Wheel ASM
1:22:3	140-2493	1	Nut-Hex, Slotted	11	99-5107	1	Nut-Lock
2	32144-49	4	Screw-HWHTF	12	144-5567	1	Cover-Wheel, Steering
3	140-9705	1	Steering Column ASM	13	144-5566	1	Clip-Wheel, Steering
5	112-3262	2	Bearing	14	144-5537	2	Spring-Compression
6	3230-1	3	Bolt-CARR	30	94-4496	5	Screw-PPH

Rear Suspension Assembly

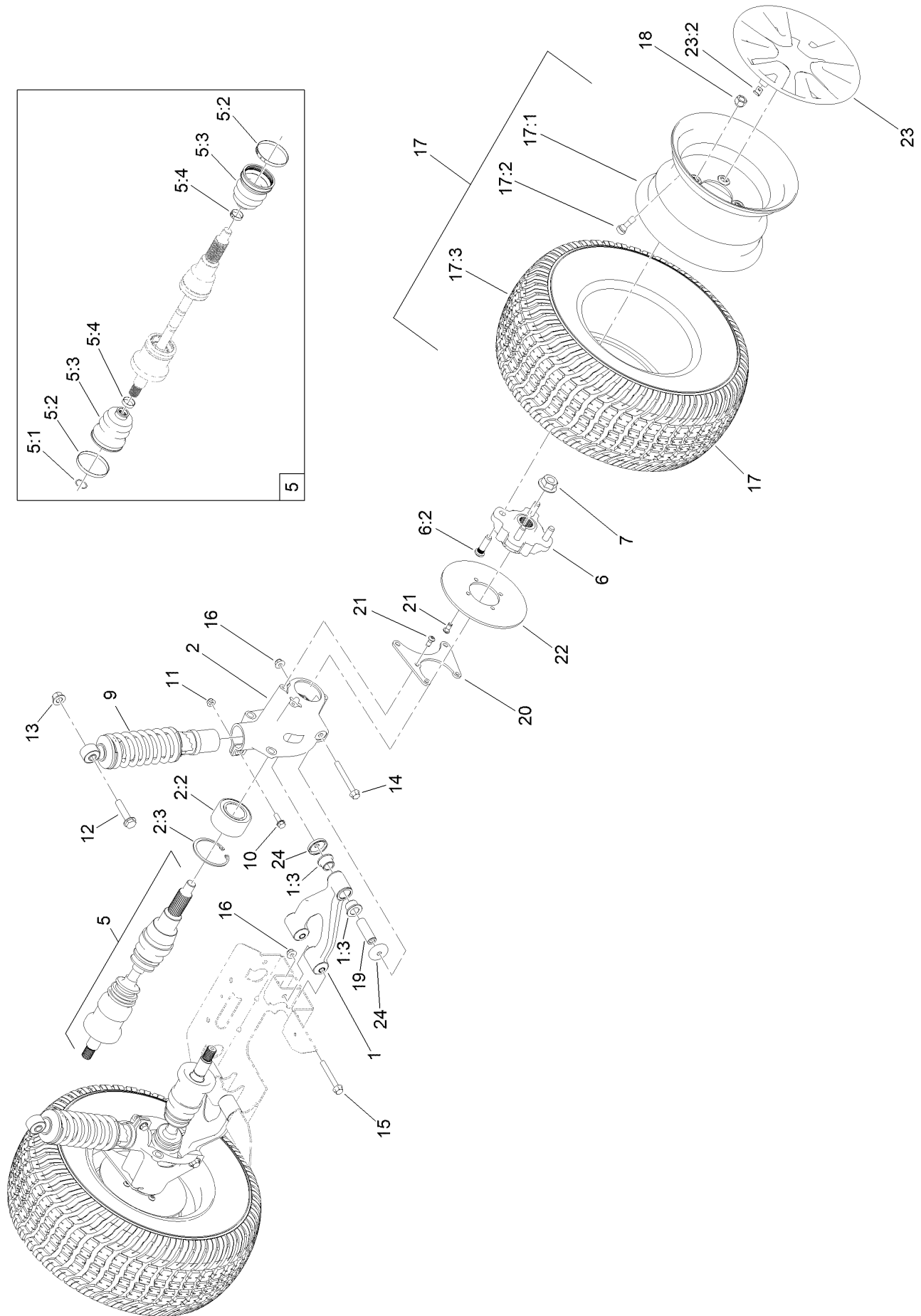

Rear Suspension Assembly (continued)

<i>Ref.</i>	<i>Part Number</i>	<i>Qty.</i>	<i>Description</i>	<i>Ref.</i>	<i>Part Number</i>	<i>Qty.</i>	<i>Description</i>
1	161-1819	2	Control Arm ASM	13	99-5107	2	Nut-Lock
1:3	147-3983	2	Bushing-Flange	14	139-3370	2	Screw-HF
2	144-5555	2	Rear Upright ASM	15	140-9853	4	Screw-HF
2:2	133-7272	1	Bearing-Ball	16	139-3380	6	Nut-HF
2:3	144-2207	1	Ring-Retaining	17	140-9801	2	Tire ASM
5	145-7062	2	Cv Axle	17:1	131-8317	1	Wheel
5:1	145-7195	1	Circlip	17:2	232-27	1	Stem-Valve
5:2	145-7196	2	Clamp	17:3	140-9794	1	Tire
5:3	145-7197	2	Boot-Cv	18	242-50	8	Nut-Lug
5:4	145-7198	2	Clamp-Cv	19	144-5634	2	Sleeve-Outer
6	145-7151	2	Rear Hub ASM	20	140-9749	2	Plate-Caliper
6:2	10-6830	4	Stud-Type, Drive	21	121-9671	14	Screw-HSBH
7	32128-53	2	Nut-HF	22	139-4474	2	Rotor-Brake
9	139-4291	2	Shock ASM	23	140-0933	2	Wheel Cover ASM
10	3234-29	2	Screw-HHF	23:2	140-0932	3	Clip-Cover, Wheel
11	104-8300	2	Nut-HF, NI	24	140-9793	4	Pin Seal
12	3234-46	2	Screw-HHF				

Brake and Throttle Pedal Assembly

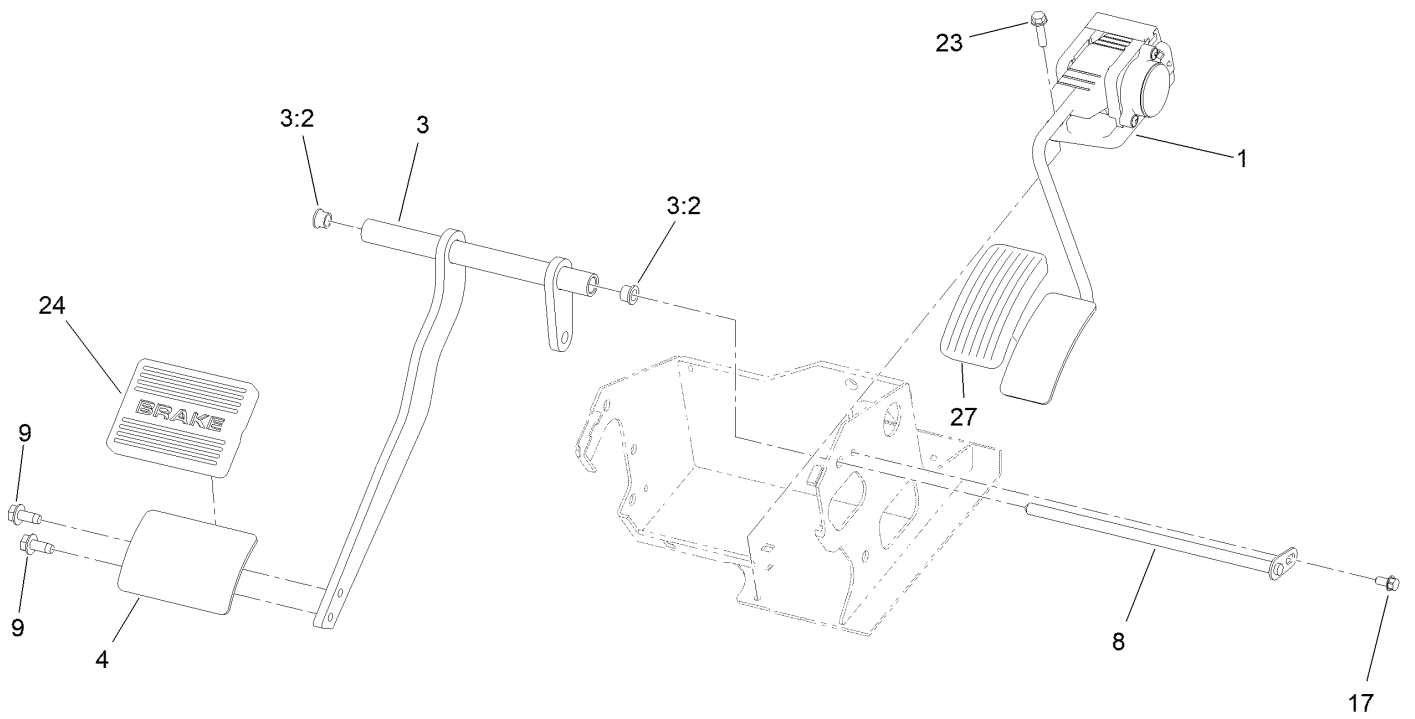

Brake and Throttle Pedal Assembly (continued)

<i>Ref.</i>	<i>Part Number</i>	<i>Qty.</i>	<i>Description</i>	<i>Ref.</i>	<i>Part Number</i>	<i>Qty.</i>	<i>Description</i>
1	140-9859	1	Throttle-Electronic	9	32144-70	2	Screw-HWHTF
3	145-7162	1	Brake Pedal ASM	17	32144-4	1	Screw-HWH
3:2	256-116	2	Bushing-Flange	23	32144-86	3	Screw-HWHTF
4	138-5763-03	1	Brake Pedal ASM	24	7-3900	1	Pad-Brake
8	140-0772	1	Flag Pin ASM	27	140-4572	1	Pedal Pad-Throttle

Front and Rear Brake Assembly

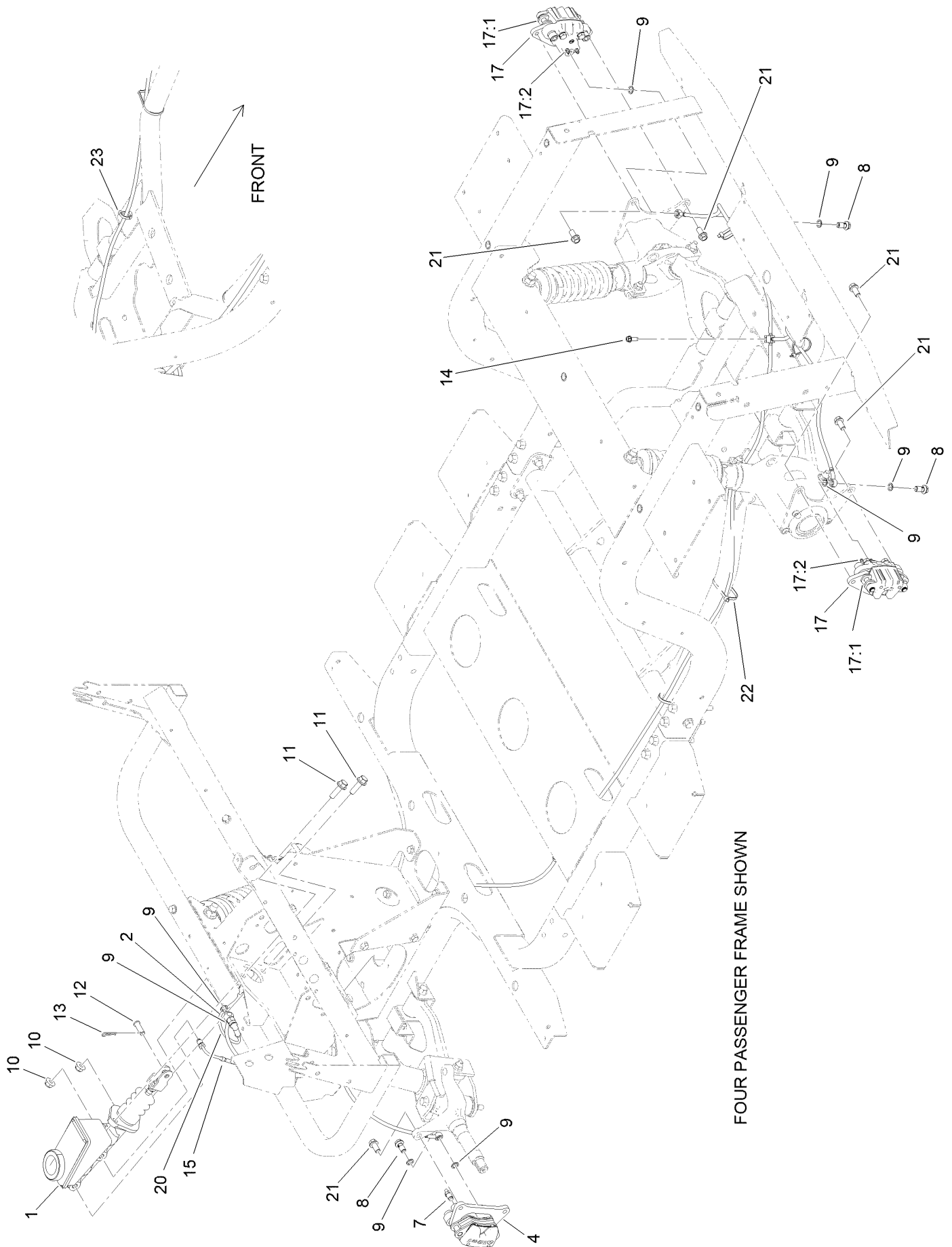

Front and Rear Brake Assembly (continued)

<i>Ref.</i>	<i>Part Number</i>	<i>Qty.</i>	<i>Description</i>	<i>Ref.</i>	<i>Part Number</i>	<i>Qty.</i>	<i>Description</i>
1	104-6782	1	Master Cylinder ASM	15	140-9994	1	Brake Line ASM
2	140-9993	1	Brake Line ASM	17	145-7159	2	Brake Caliper ASM
4	140-2575	2	Brake Caliper ASM	17:1	140-2595	1	Brake Pad Service Kit (Rear, Qty 4)
7	119-9509	2	Screw-Bleed	17:2	145-7149	1	Fitting-Bleed Screw
8	120-4875	4	Bolt-Flange, Banjo	17:3	136-6328	2	Spring-Rattle, Anti ●
9	115-2341	10	Washer-Banjo	20	144-2227	1	Switch-Brake, Pressure
10	104-8301	2	Nut-HF, NI	21	144-5550	8	Screw-Spl
11	119-4061	2	Screw-HHF	22	3290-378	6	Tie-Cable
12	283-2	1	Pin-Clevis	23	32180-030	1	Clip-Tie
13	1-806003	1	Pin-Cotter				
14	49-2040	2	Screw-HWHTF				

● Not illustrated



Master Cylinder Assembly No. 104-6782

Ref.	Part Number	Qty.	Description
1	104-6845	1	Reservoir ASM
1:1	92-4112	1	Cap ASM
2	93-8971	2	Seal-Port, Flange
3	92-4103	1	Pin-Stop
4	92-4102	1	Secondary Piston ASM
5	92-4110	1	Clevis
6	21-0360	1	Nut-Hex
7	94-5209	1	Cover-Dust
8	94-5210	1	Rod-Push
9	92-4109	1	Ring-Snap
10	92-4108	1	Retainer-Washer
11	92-4101	1	Primary Piston ASM

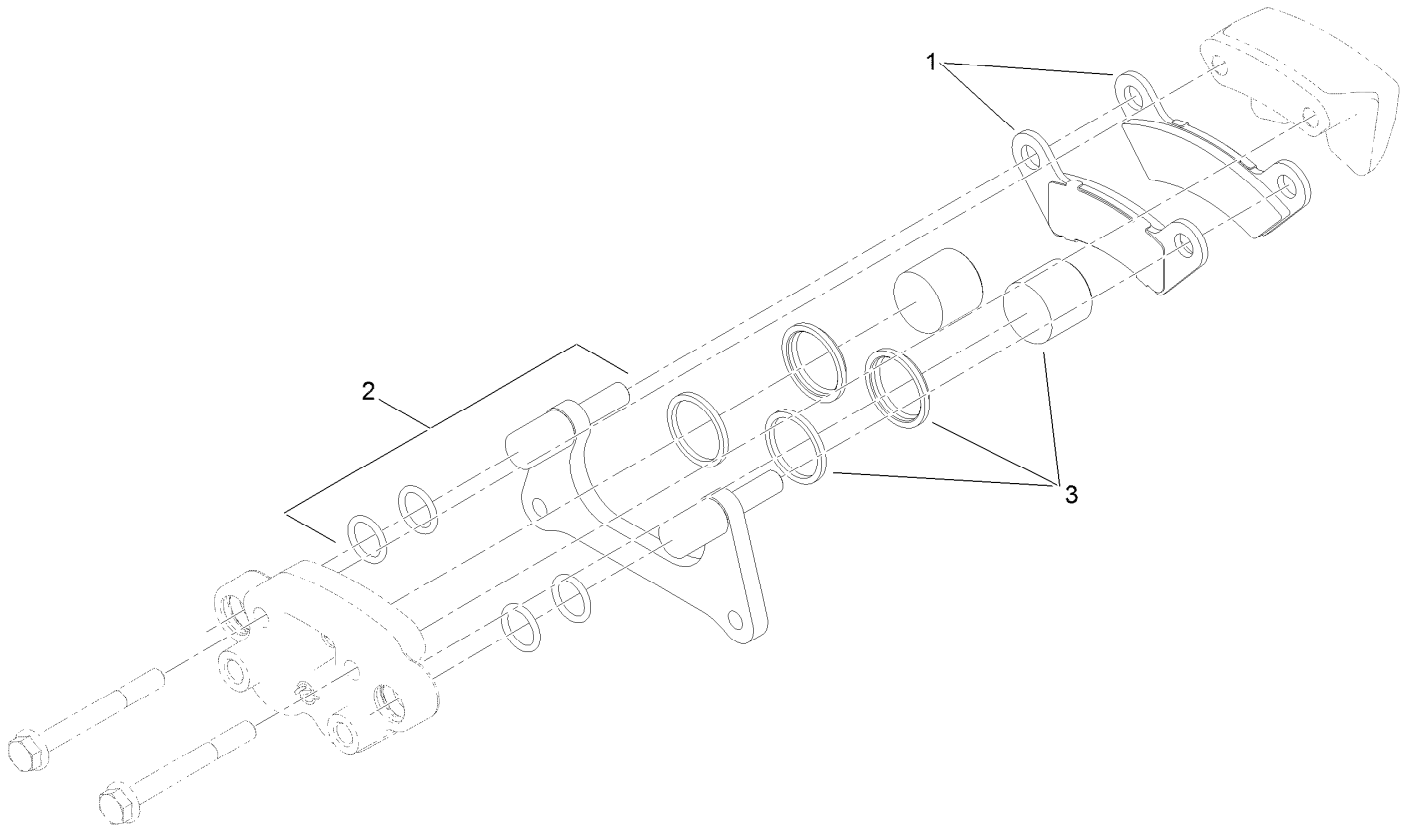

Brake Caliper Assembly No. 140-2575

<i>Ref.</i>	<i>Part Number</i>	<i>Qty.</i>	<i>Description</i>
1	140-2580	1	Brake Pad Service Kit (Front, Qty 4)
2	119-9511	1	Bracket Kit
3	133-0614	1	Piston Kit

Hood, Front Fenders and Dash Assembly

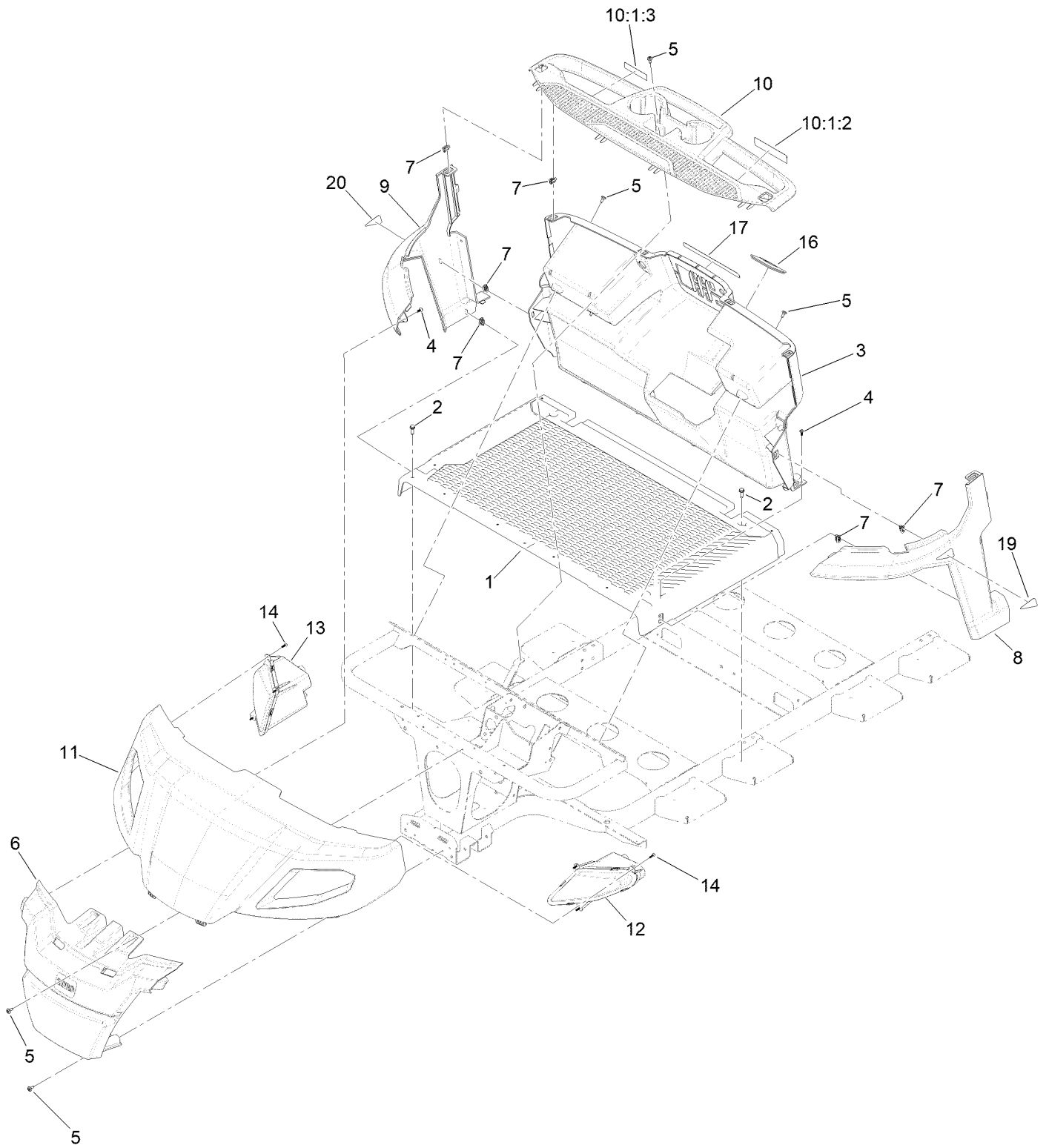

Hood, Front Fenders and Dash Assembly (continued)

<i>Ref.</i>	<i>Part Number</i>	<i>Qty.</i>	<i>Description</i>	<i>Ref.</i>	<i>Part Number</i>	<i>Qty.</i>	<i>Description</i>
1	140-0850SP	1	Floor-Front	10:1:3	144-5574	1	Decal-Vista Safety, Passenger
2	701243	5	Screw-Thd Roll, HWH	11	145-7200SP	1	Hood-Vista, Beige
3	140-9901SP	1	Dash	12	140-0890	1	Headlight-LH
4	138-5775	10	Screw-Delta Point	13	140-0891	1	Headlight-RH
5	120-7950	8	Screw-Torx	14	140-9930	6	Screw-Bhf, Plastic
6	140-0845SP	1	Bumper-Front	16	144-5505	1	Grommet-Column, Steering
7	140-9908	10	Clip-Trim	17	144-5573	1	Decal-Control Panel, Electric
8	140-0842SP	1	Fender-Front, LH	19	140-0941	1	Decal-Reflector, Front, LH
9	140-0843SP	1	Fender-Front, RH	20	140-0942	1	Decal-Reflector, Front, RH
10	145-7050SP	1	Dash-Top 4P				
10:1:2	144-5571	1	Decal-Vista Safety, Driver				

Main Seat and Rear Fenders Assembly

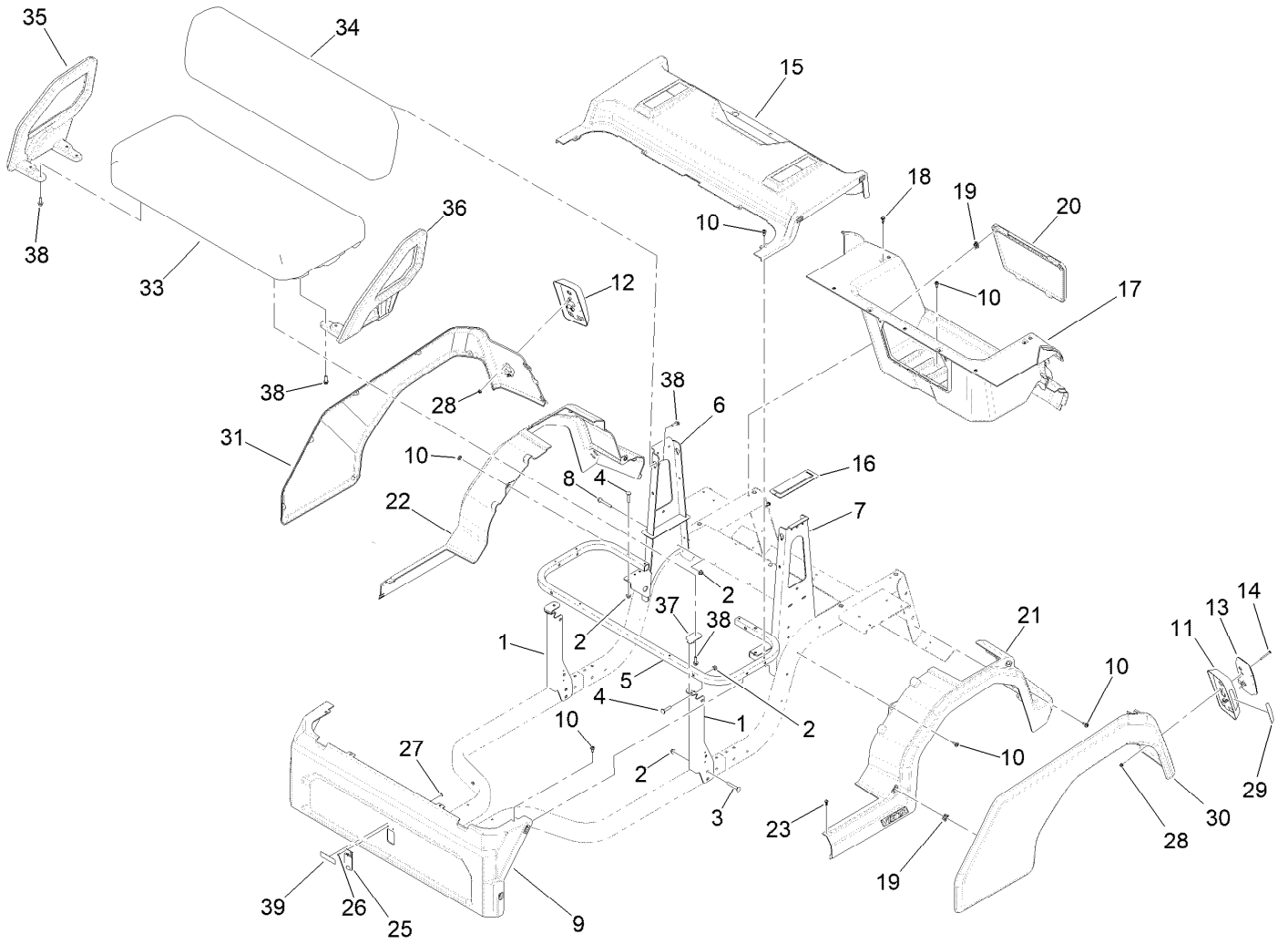

Main Seat and Rear Fenders Assembly (continued)

<i>Ref.</i>	<i>Part Number</i>	<i>Qty.</i>	<i>Description</i>	<i>Ref.</i>	<i>Part Number</i>	<i>Qty.</i>	<i>Description</i>
1	140-0800-03	2	Bracket-Support, Seat Frame	19	140-9908	14	Clip-Trim
2	104-8300	12	Nut-HF, NI	20	140-0866	1	Door-Access, Rear
3	3230-7	4	Bolt-CARR	21	140-0847SP	1	Fender-Rear, LH
4	3230-4	4	Bolt-CARR	22	140-0848SP	1	Fender-Rear, RH
5	140-9788-03	1	Tube-Frame, Seat Bottom	23	138-5775	2	Screw-Delta Point
6	144-5623-03	1	Bracket-Back, RH	25	144-6628	1	Plate-Cover, Spring
7	144-5622-03	1	Bracket-Back, LH	26	3290-271	2	Rivet-Pop
8	139-4479	4	Screw-HHF	27	3269-10	2	Washer-Back
9	147-3889SP	1	Panel-Base, Seat	28	138-0719	4	Nut-HF
10	120-7950	14	Screw-Torx	29	140-0943	2	Decal-Reflector, Rear
11	140-9910	1	Housing-Tail Light, LH	30	145-7210SP	1	Panel-Rear, LH Beige
12	140-9911	1	Housing-Tail Light, RH	31	145-7220SP	1	Panel-Rear, RH Beige
13	139-2071	2	Light-Rear Tail/Stop/Turn	33	140-9941SP	1	Seat Bottom ASM-Beige
14	3250-48	4	Screw-PPH	34	140-9943SP	1	Seat Backrest ASM-Beige
15	140-0846SP	1	Cover-Rear	35	140-0804SP	1	Restraint-Hip, RH
16	140-9904	2	Grommet-Bracket, Seat	36	140-0803SP	1	Restraint-Hip, Driver
17	140-0851SP	1	Tub-Rear	37	140-0812	2	Bracket-Hinge, Seat
18	125-9622	8	Rivet-Blind	38	115-5142	14	Screw-HHF
				39	140-4590	1	Decal-Charger Input Lithium

Rear Facing Seat Assembly

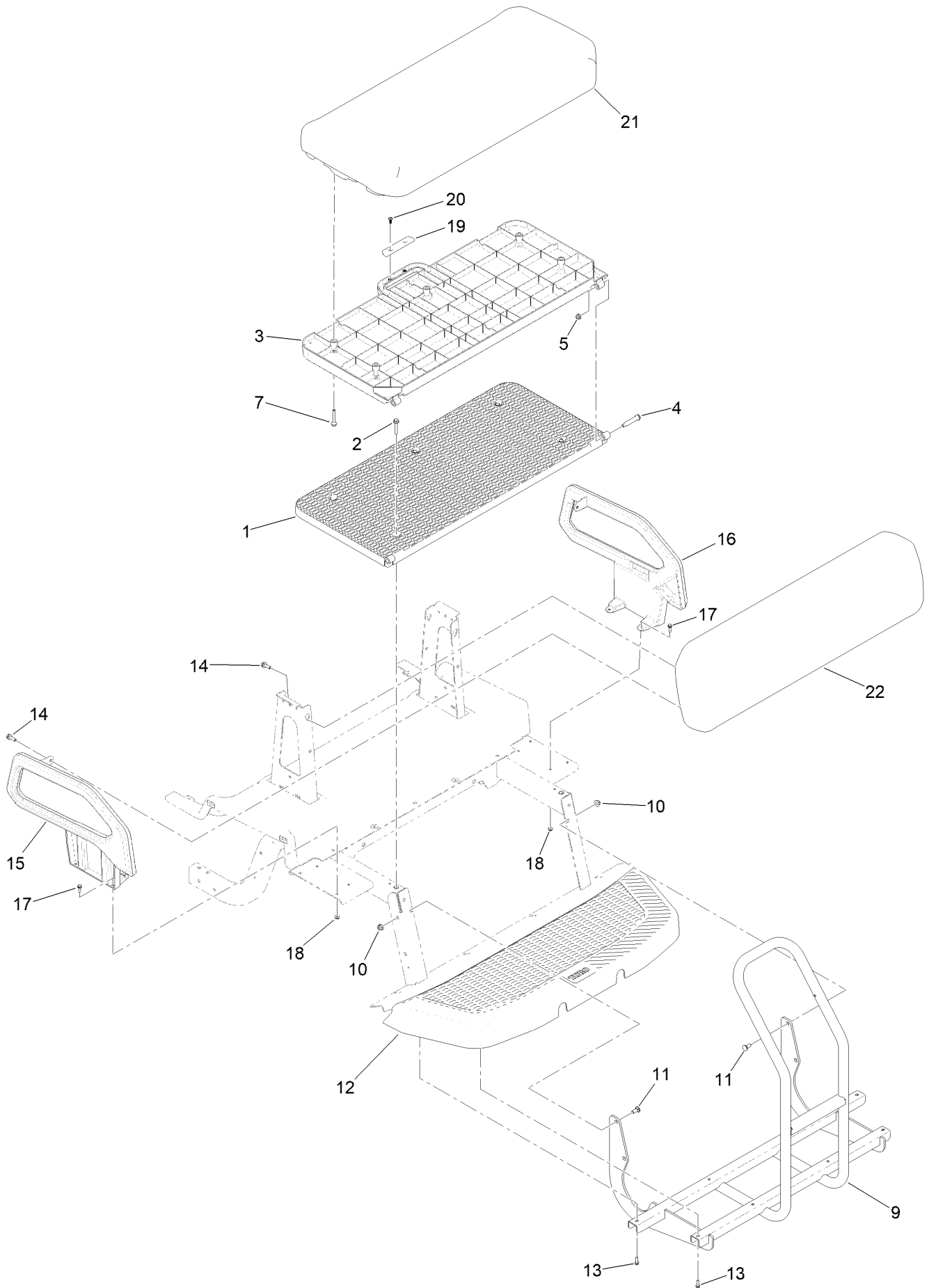

Rear Facing Seat Assembly (continued)

<i>Ref.</i>	<i>Part Number</i>	<i>Qty.</i>	<i>Description</i>	<i>Ref.</i>	<i>Part Number</i>	<i>Qty.</i>	<i>Description</i>
1	140-0821SP	1	Floor-Box, Cargo	13	46-8091	8	Screw-HWH
2	145-7105	5	Screw-HHF	14	115-5142	6	Screw-HHF
3	140-0820SP	1	Floor-Flip Seat	15	140-0833	1	Restraint-Hip, LH Rear
4	136-7199	2	Bolt-Shoulder	16	140-0834	1	Restraint-Hip, RH Rear
5	104-8300	2	Nut-HF, NI	17	32105-15	8	Screw-HWH
7	140-9909	5	Screw-HHF	18	104-7201	8	Nut-HF, NI
9	140-0875SP	1	Rear Floor Frame ASM	19	145-7100	1	Bumper-Rubber, Flip Seat
10	104-8301	4	Nut-HF, NI	20	138-5775	2	Screw-Delta Point
11	3231-12	4	Bolt-CARR	21	140-9941SP	1	Seat Bottom ASM-Beige
12	140-0872	1	Floor-Rear	22	140-9943SP	1	Seat Backrest ASM-Beige

Batteries, Motor and Transaxle Assembly

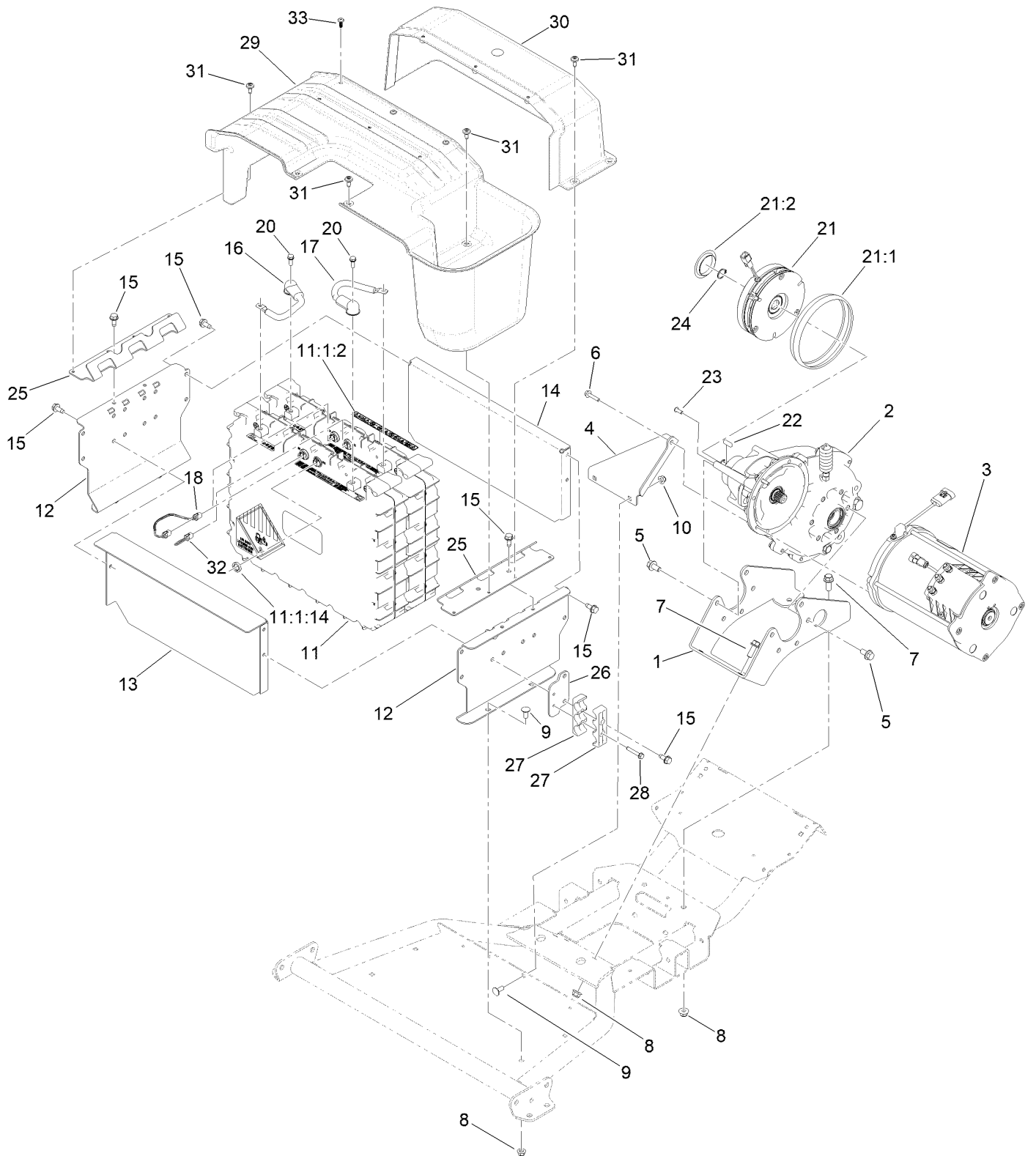

Batteries, Motor and Transaxle Assembly (continued)

<i>Ref.</i>	<i>Part Number</i>	<i>Qty.</i>	<i>Description</i>	<i>Ref.</i>	<i>Part Number</i>	<i>Qty.</i>	<i>Description</i>
1	140-9822-03	1	Bracket-Mount, Trans	18	140-9565	1	Harness-Wire, Data Interface
2	145-7060	1	Transaxle-Electric	20	145-5783	2	Screw-Sems
3	137-6936	1	Motor-AC	21	145-7061	1	Brake-Electric
4	140-9797-03	1	Brace-Motor	21:1	145-7184	1	Dust Cover
5	139-6300	10	Screw-Hfl	21:2	145-7186	1	End Cap
6	33103-030	6	Screw-HHF	22	145-7163	1	Key-Square
7	3234-42	4	Screw-HHF	23	145-7164	3	Screw-HSBH
8	104-8301	4	Nut-HF, NI	24	32120-15	1	Ring-Snap, EXT
9	3230-1	6	Bolt-CARR	25	145-7171-03	2	Bracket-Battery, Hold
10	104-8300	6	Nut-HF, NI	26	145-7175	1	Bracket-Clamp, Cable
11	145-5320	2	Battery ASM	27	145-7166	2	Clamp-Cable
11:1:2	145-5338	1	Decal-Warning, Battery	28	94-2691	2	Screw-HWH Taptite
11:1:14	32180-466	2	Nut-Mounting, Jwvf Panel Lock	29	145-7178	1	Cover-Front, Battery
12	144-5440-03	2	Bracket-Battery, Side	30	145-7177	1	Cover-Rear, Battery
13	145-7170-03	1	Panel-Battery, Front	31	120-7950	11	Screw-Torx
14	145-7169-03	1	Panel-Battery, Rear	32	122-2323	1	Harness-Wire, Can Terminator
15	32144-70	12	Screw-HWHTF	33	138-5775	3	Screw-Delta Point
16	145-7275	1	Cable-Battery, Rd ASM				
17	145-7276	1	Cable-Battery, Bk ASM				

Transaxle Assembly No. 145-7060

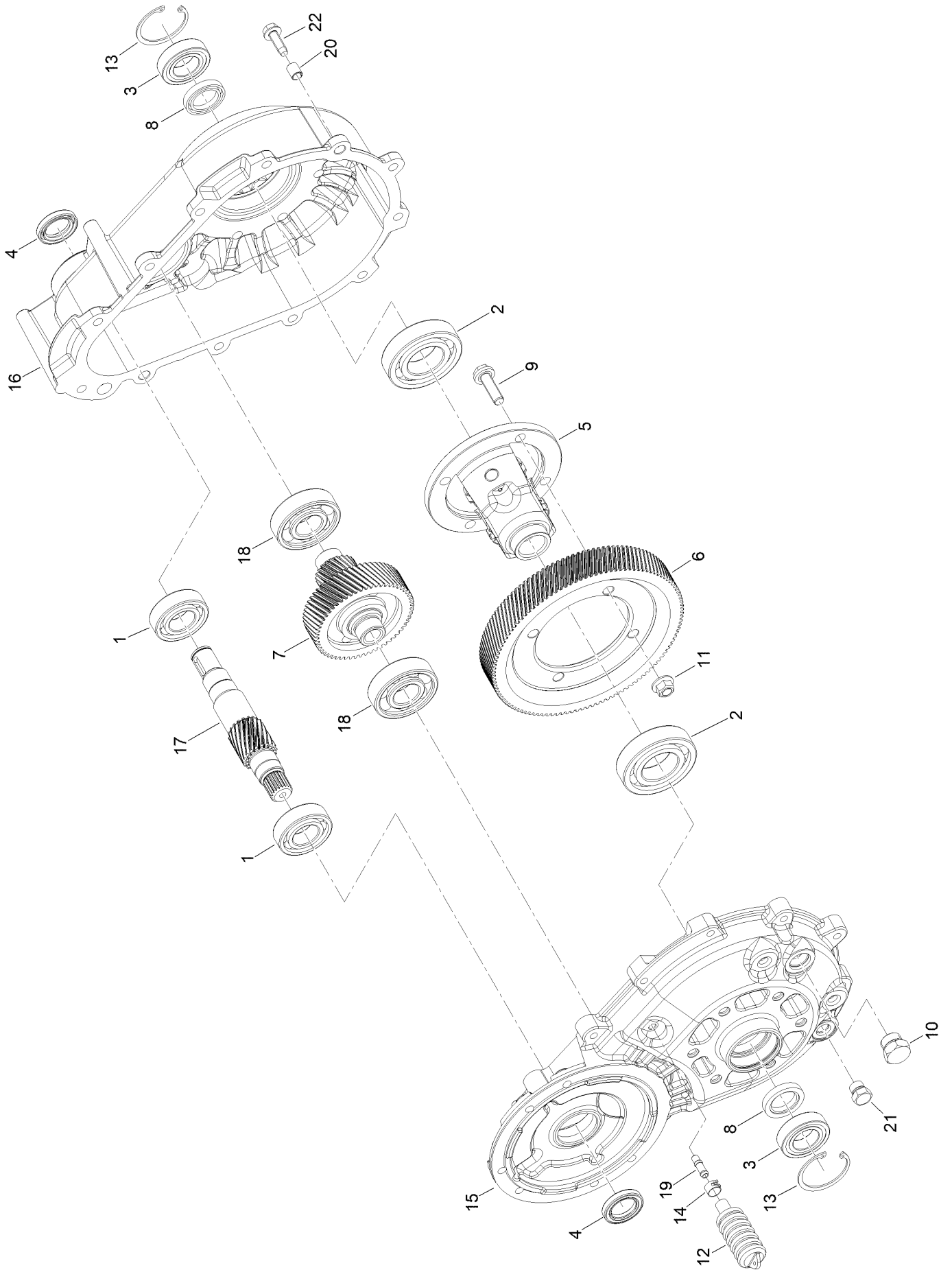

Transaxle Assembly No. 145-7060 (continued)

<i>Ref.</i>	<i>Part Number</i>	<i>Qty.</i>	<i>Description</i>	<i>Ref.</i>	<i>Part Number</i>	<i>Qty.</i>	<i>Description</i>
1	145-7286	2	Bearing, Ball, Single Row, 6205	10	133-2466	1	Plug-HH
2	145-7287	2	Bearing, Ball, Single Row, 6207	11	133-2463	4	Nut-Lock
3	145-7288	2	Bearing, Ball, Single Row, 6005-2Rs	12	145-7294	1	Vent, Bellows
4	145-7289	2	Seal, Oil, .945 Shaft, 1.499 Bore	13	133-2450	2	Ring-Retaining
5	145-7290	1	Assembly, Differential Case, Standard	14	145-7295	1	Clamp, Hose
6	145-7291	1	Gear, Helical, Output, Finish, 116T	15	145-7296	1	Housing, Machined, Left
7	145-7292	1	Assembly, Shaft And Gear, Intermediate	16	145-7297	1	Housing, Machined, Right
8	145-7293	2	Seal, Oil, 25 MM Shaft, 1.499 Bore	17	145-7298	1	Shaft, Input, 18T
9	133-2462	4	Bolt-HHF	18	145-7299	2	Bearing, Ball, Single Row, 6305
				19	147-4096	1	Tube, Vent
				20	145-7301	2	Bushing, Dowel, .313 X .500
				21	145-7302	1	Drain Plug, Magnetic, O-Ring, 1/2-20
				22	147-4095	12	Screw, Hex Head, 5/16-18, Thread Forming

Electric Motor Assembly No. 137-6936

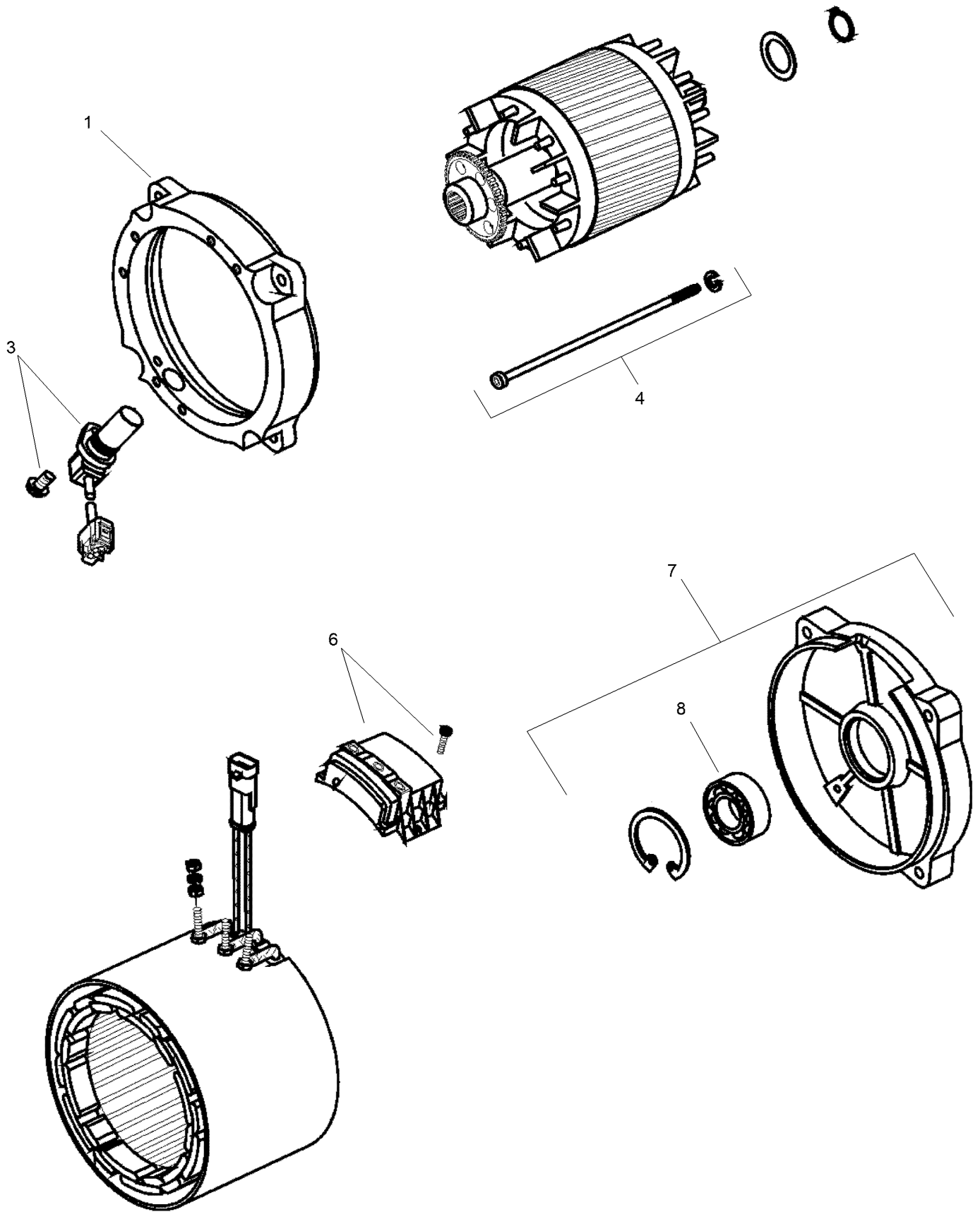

Electric Motor Assembly No. 137-6936 (continued)

<i>Ref.</i>	<i>Part Number</i>	<i>Qty.</i>	<i>Description</i>
1	132-4924	1	Bracket-End, Drive
3	132-4925	1	Sensor
4	132-4926	1	Screw

<i>Ref.</i>	<i>Part Number</i>	<i>Qty.</i>	<i>Description</i>
6	132-4927	1	Plate-Connection
7	132-4928	1	Bracket-End, Rear
8	132-4929	1	Bearing

Dash Electrical Components Assembly

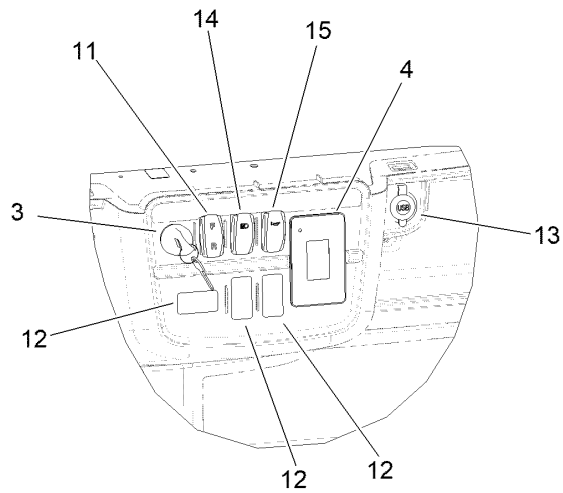
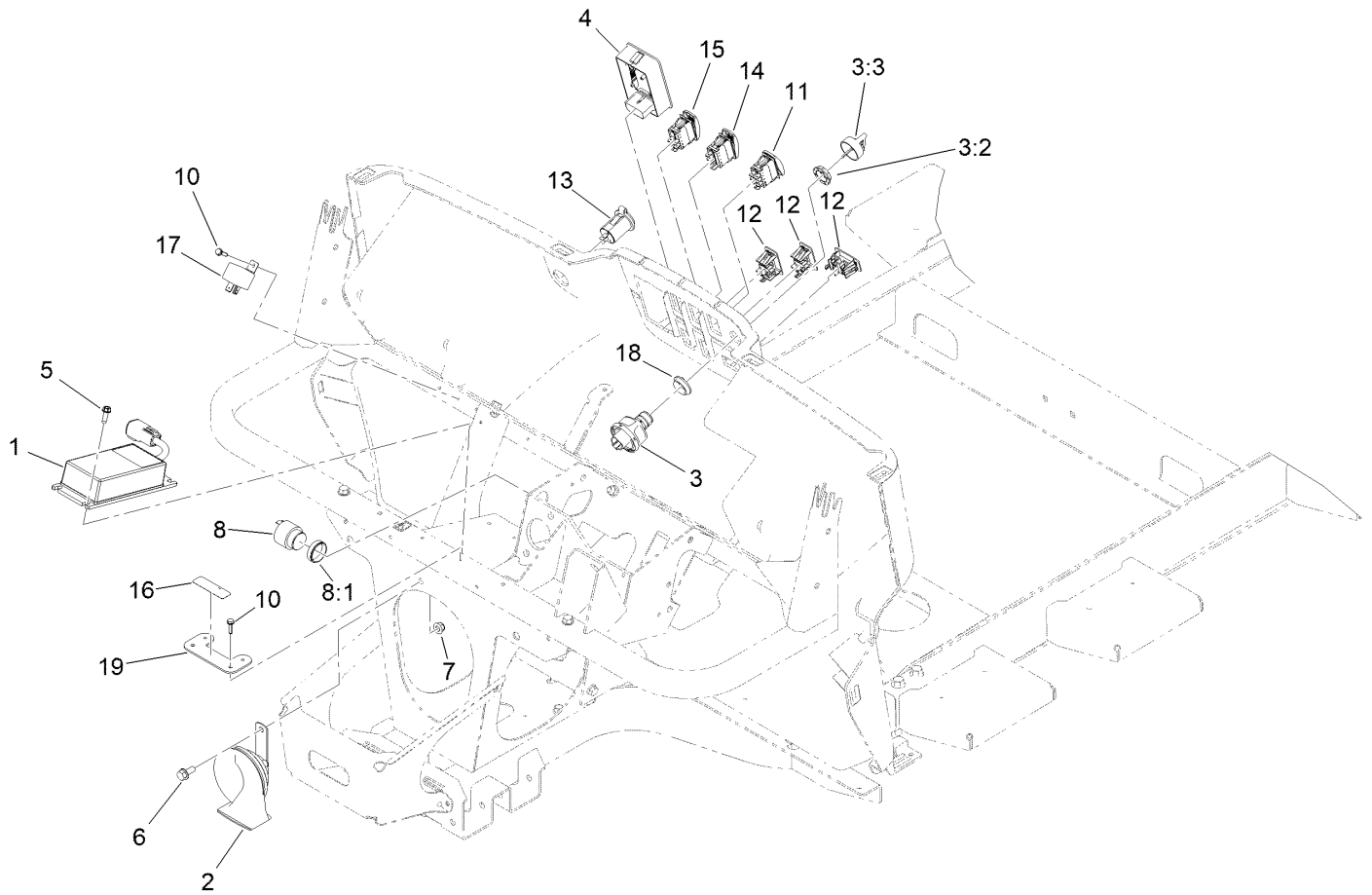

DASH VIEW

Dash Electrical Components Assembly (continued)

<i>Ref.</i>	<i>Part Number</i>	<i>Qty.</i>	<i>Description</i>	<i>Ref.</i>	<i>Part Number</i>	<i>Qty.</i>	<i>Description</i>
1	144-6975	1	Converter DC-DC	11	122-2654	1	Switch-Rocker, On-None-On
2	107-0358	1	Horn	12	119-7791	3	Plug-Hole
3	122-2513	1	Switch-Ignition, Suns	13	140-7955	1	Port-Power, USB
3:1	121-5160	1	Nut-Hex ●	14	144-2405	1	Switch-Rocker, On-None-On
3:2	122-2704	1	Nut-Face, M22 (Plastic)	15	144-2415	1	Switch-Rocker, (On)-None-Off
3:3	121-5162	1	Set-Key, Ignition	16	144-5576	1	Decal-Fuse Block, 12V/60V
4	122-2152	1	Controller, Tdm-1601	17	122-2400	1	Relay, 12V Coil, 50A At 48V
5	49-2040	2	Screw-HWHTF	18	145-7110	1	Adapter-Switch, Key
6	3234-5	1	Screw-HHF	19	144-5367-03	1	Bracket-Fuse
7	104-8300	1	Nut-HF, NI				
8	80-9330	1	Audio Alarm ASM				
8:1	104-5107	1	Nut-Plastic, Knurled				
10	100-4351	5	Screw-HWH				

● Not illustrated

Electrical Assembly

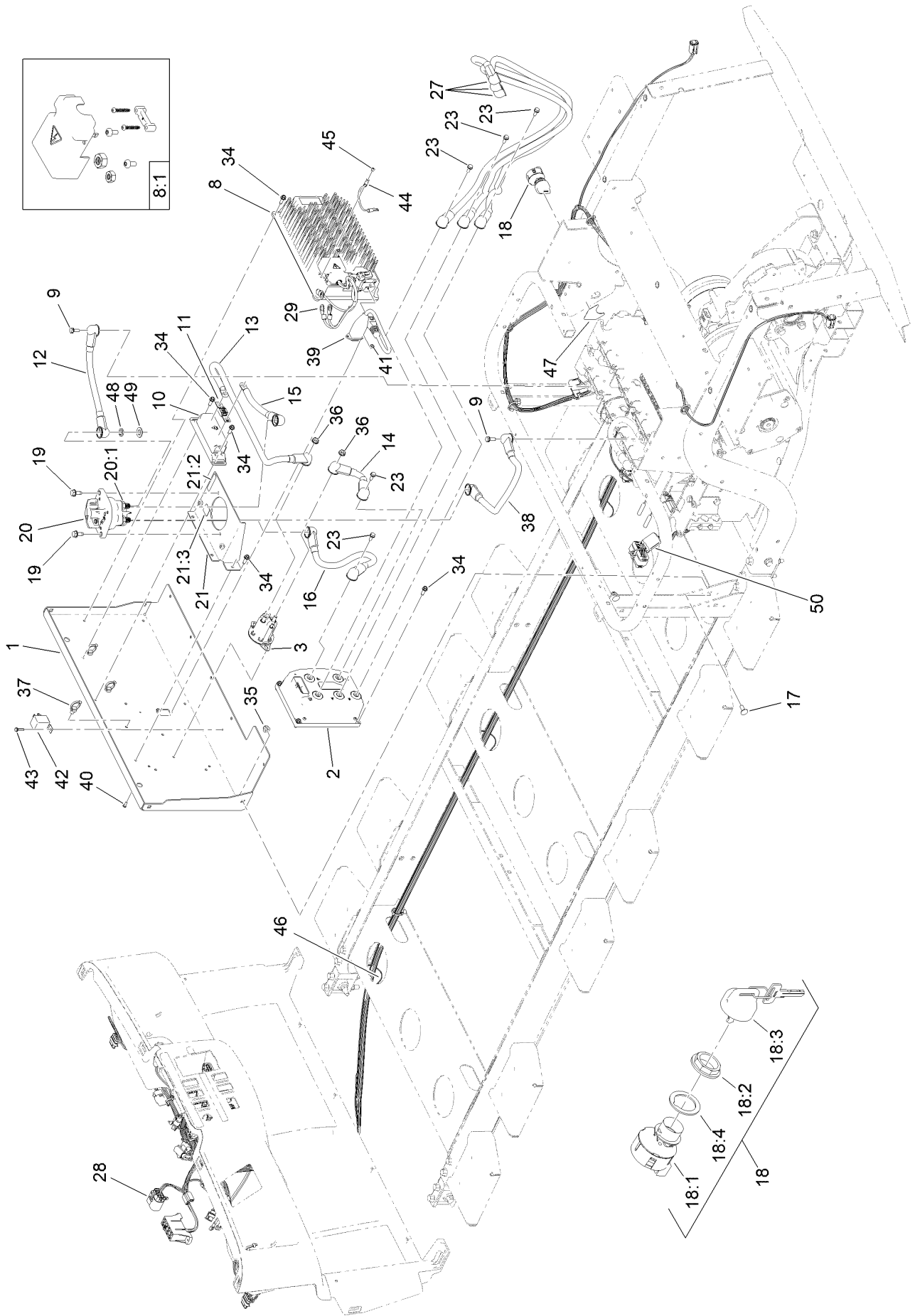

Electrical Assembly (continued)

<i>Ref.</i>	<i>Part Number</i>	<i>Qty.</i>	<i>Description</i>	<i>Ref.</i>	<i>Part Number</i>	<i>Qty.</i>	<i>Description</i>
1	145-7167-03	1	Plate-Electrical	23	145-5782	5	Screw-Sems
2	145-7270	1	Inv/Ctrlr-48V	27	145-7279	3	Cable-Battery,Rd ASM
3	122-2616	1	Contactora-Powerseal	28	122-1591	1	Harness-Wire, Vista, Electric
8	144-5475	1	Charger-Onboard, 900W	29	122-2703	1	Harness-Wire, Charger Power Interface
8:1	140-2494	1	Charger Kit-Service	34	49-2040	15	Screw-HWHTF
9	145-5783	2	Screw-Sems	35	104-8300	4	Nut-HF, NI
10	145-4958	1	Holder-Fuse	36	107-0380	2	Nut-HF
11	122-2561	1	Fuse-200A	37	32180-030	3	Clip-Tie
12	147-3879	1	Cable-Battery,Rd ASM	38	147-3883	1	Cable-Battery,Bk ASM
13	147-3881	1	Cable-Battery,Rd ASM	39	145-7147	1	Cordset W/Filter
14	147-3882	1	Cable-Battery,Rd ASM	40	3250-26	2	Screw-PPH
15	147-3880	1	Cable-Battery,Rd ASM	41	3296-54	2	Nut-Lock
16	147-3884	1	Cable-Battery,Bk ASM	42	122-3200	1	Relay - Dg57CM
17	3230-23	4	Bolt-CARR	43	100-4351	1	Screw-HWH
18	110-2580	1	Switch-Key, Supervisor	44	122-2792	1	Harness-Wire, Charger Bonding
18:1		1	Switch-Key ●	45	161-1826	2	Screw-Ground
18:2	108-8660	1	Nut-Mounting	46	3290-378	1	Tie-Cable
18:3	110-5221	1	Set-Key, Supervisor	47	140-0924	1	Decal-Mode
18:4	108-8659	1	Washer-Backup	48	HDW14457	4	Split Lock Washer,1/2,ST/ST,18-8
19	32144-70	2	Screw-HWHTF	49	147-3238	4	Washer-Flat
20	122-0603	1	Switch-Disconnect	50	147-8183	2	Ferrite, Snap-On
20:1	33006-00	1	Nut-HF				
21	147-3964	1	Disconnect Bracket ASM				
21:2	120-9570	1	Decal-Warning				
21:3	145-7345	1	Decal-Voltage, High				

● Not serviced separately

Wire Harness Assembly No. 122-1591

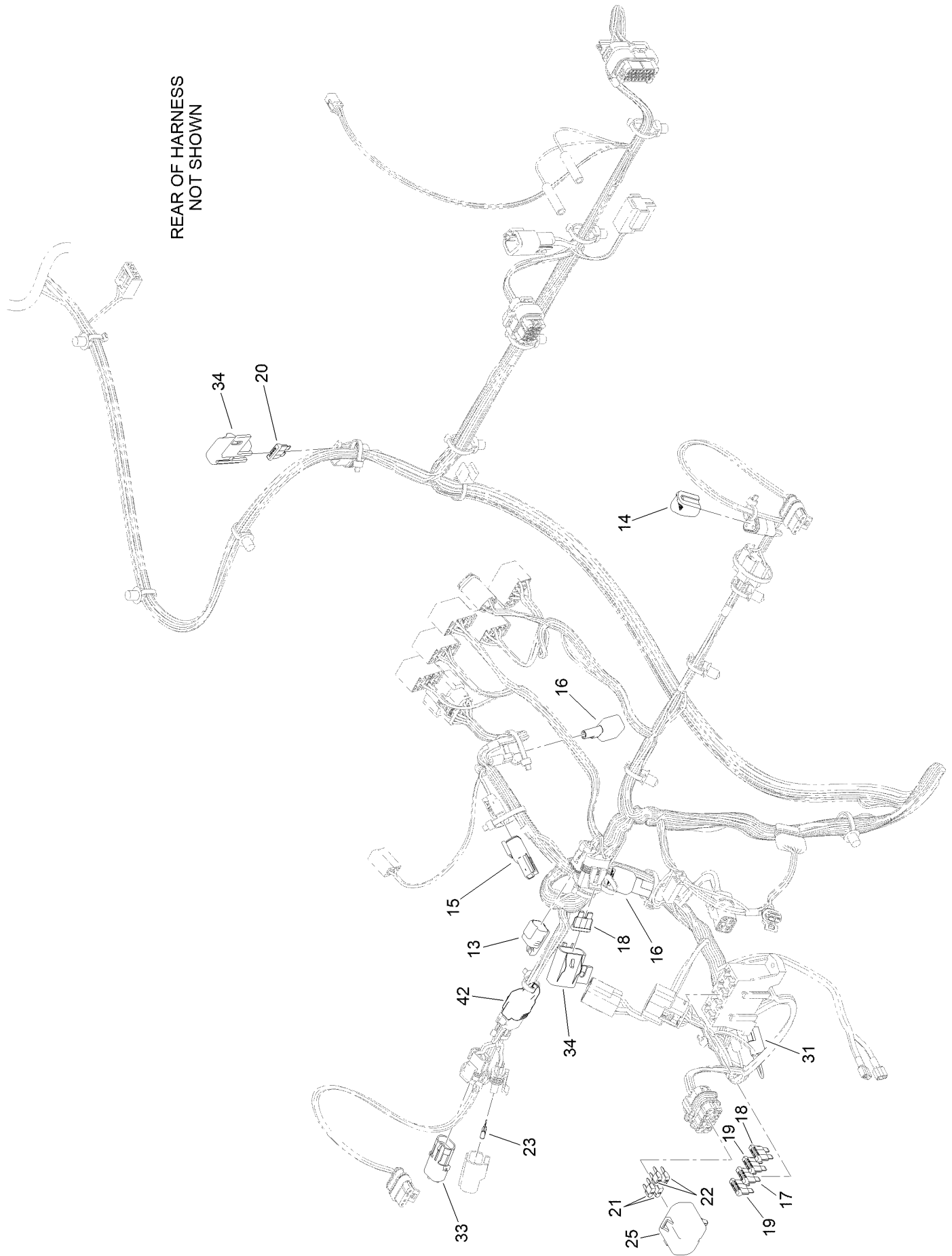

Wire Harness Assembly No. 122-1591 (continued)

<i>Ref.</i>	<i>Part Number</i>	<i>Qty.</i>	<i>Description</i>	<i>Ref.</i>	<i>Part Number</i>	<i>Qty.</i>	<i>Description</i>
13	32180-091	2	Cap-Dust, 2 Way	22	121-8865	2	Fuse-Mini Blade, 7.5 Amp
14	32180-089	1	Cap-Plug, 3 Way	23	121-8868	1	Fuse-Mini Blade, 20 Amp
15	32180-282	1	Resistor-120 Ohm	25	32180-181	1	Cover-Cooper-Bussman, Atm ST Pin Brkt
16	100-4918	2	Diode	31	32180-416	1	Cap-Tethered
17	117-4722	1	Fuse-Blade, 5A	33	32160-072	1	Connector-Wp,2M
18	117-4724	2	Fuse-Blade, 10A	34	32180-019	2	Cover-Fuse, Single
19	117-4726	2	Fuse-Blade, 20A	42	32180-156	1	Cap-Plug, 6 Way
20	117-4728	1	Fuse-Blade, 30A				
21	121-8864	2	Fuse-Mini Blade, 5 Amp				

Attachments and Accessories

For 08924 Vista 4 Passenger Lithium Shuttle Vehicle

Product Name	Model/Part
Folding Windshield Kit	08220
Beige Canopy, Vista 4 Passenger Shuttle Vehicle	08226
Beacon Kit	08225
Turn Signal Kit	144-5587
Side Mirrors Kit	145-7140
Rear View Mirror Kit.....	08141
Wide Angle Mirror Kit.....	133-1038
Wide Angle Mirror Kit.....	133-1009
Battery ASM	145-5320
Energy Expansion Kit, Vista Shuttle Vehicle	147-4090
Universal Wireless Hourmeter Kit	144-2436
External Antenna Kit, Wireless Hourmeter System	115-9524
Base Station Kit, Wireless Hourmeter System	115-9542
Repeater Kit, Wireless Hourmeter System	115-9543
Powercord-AC, Europe.....	107-0382
Powercord-AC, U.K.	107-0383
Powercord-AC	107-0384
Cargo Box, Vista Shuttle Vehicle	08228

Notes:

Notes:

Notes:



Count on it.