



Jack Mount Kit

TimeCutter® Riding Mower

Model No. 147-8836

Installation Instructions

Safety

Safety and Instructional Decals



Safety decals and instructions are easily visible to the operator and are located near any area of potential danger. Replace any decal that is damaged or missing.

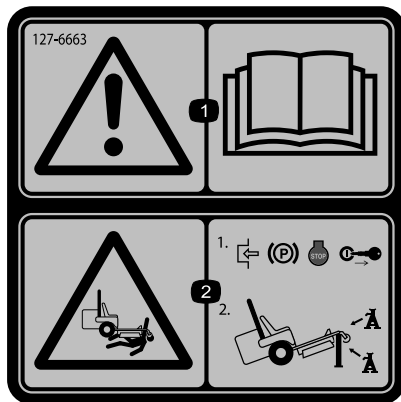

127-6663

decal127-6663

1. Warning—read the *Operator's Manual*.
2. Crushing hazard—engage the parking brake, shut off the engine, and remove the key; support the machine using jackstands.

Installation

Determine the left and right sides of the machine from the normal operating position.

Preparing the Machine

Gas Models Only

1. Park the machine on a level surface.
2. Disengage the blade-control switch.
3. Move the motion-control levers outward to the PARK position.
4. Shut off the machine and remove the key.
5. Wait for all moving parts to stop.

Electric Models Only

1. Park the machine on a level surface.
2. Disengage the blade-control switch.
3. Move the motion-control levers outward to the NEUTRAL position.
4. Engage the parking brake.
5. Shut off the machine and remove the key.
6. Wait for all moving parts to stop.



Installing the Jack Mount

1. Secure the jack mount to the left axle tube on the front of the machine using 2 U-bolts and 4 locknuts (Figure 1).

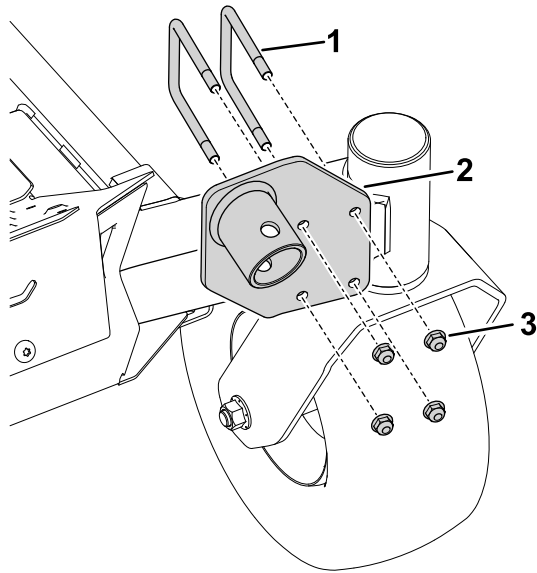

Figure 1

g467170

1. U-bolt
2. Jack mount

3. Locknut

-
2. Torque the fasteners to 19 to 25 N·m (175 to 225 in-lb).

Operation

Using the Jack Mount

⚠ WARNING

The machine could fall onto someone and cause serious injury or death.

- Read and understand the *Operator's Manual* before performing maintenance.
- Always shut off the engine, engage the parking brake, and remove the key before performing maintenance on the machine.
- Do not keep the machine raised on the jack for extended periods of time.
- Always use a jack on a level surface.
- Ensure that the jack is secured properly to the jack mount using a jack pin.
- Do not rely solely on the jack for support. Use adequate jack stands or equivalent support.
- Do not mount or dismount the mower while the jack is raised.
- Before each use, ensure that the jack and jack mount work properly and that there are no signs of damage.

Note: Use only a manufacturer-approved jack rated at 907 kg (2,000 lb) or higher lift capacity with the jack mount.

1. Park the machine on a level surface, disengage the blade-control switch, and move the motion-control levers outward to the PARK position.

Note: For electric models, move the motion-control levers outward to the NEUTRAL position and engage the parking brake.

2. Shut off the machine, remove the key, and wait for all moving parts to stop before leaving the operating position.
3. Attach the jack to the jack mount with a jack pin (Figure 2).

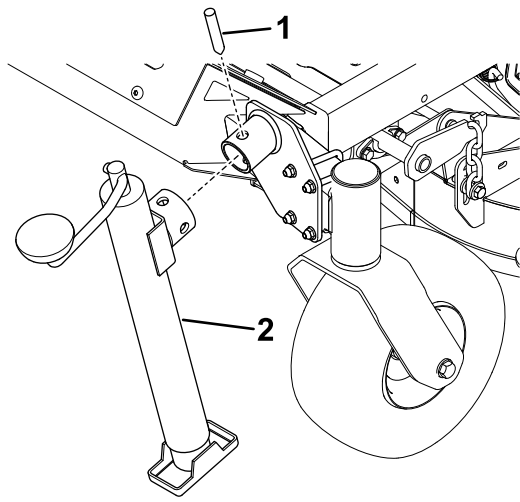

g467171

Figure 2

1. Jack pin 2. Jack

-
4. Use the jack to raise the machine to the desired height.

⚠ WARNING

Raising the machine could cause a fuel leak.

- **Check for any fuel leaks before performing maintenance.**
 - **If you see a fuel leak, immediately lower the machine and do not attempt to start the engine. Avoid creating a source of ignition until the fuel vapors have dissipated.**
5. Support the machine with jack stands; refer to the machine *Operator's Manual* for jack stand placement.
6. When finished, use the jack to lower the machine, then remove the jack.

Note: Do not operate the machine with the jack attached.



Count on it.