

Parts Catalog

Twin Bagger

50in or 54in Zero-Turn-Radius Riding Mower

Model No. 79501—Serial No. 400000000 and Up



Ordering Replacement Parts

To order replacement parts, please supply the part number, the quantity, and the description of each part desired.

Understanding Reference Numbers

Each identified part in an illustration has a reference number. The reference number for a part also appears in the parts list, along with other information about the part.

This catalog uses two special reference number formats, one to indicate parts in a service assembly and another to indicate the quantity of a given part in an illustration.

Service Assembly Reference Numbers

Parts in service assemblies have reference numbers in the form a:b. The a represents the reference number of the entire service assembly and the b represents a sequential number unique to each part within the service assembly.

For example, a wheel assembly might be identified by reference number 6, the tire by 6:1, the valve by 6:2, and the wheel by 6:3. When you order the assembly identified by reference number 6, you receive all parts identified by reference numbers 6:1, 6:2, and 6:3. However, you may also order any part individually. Reference numbers of this type appear in illustration and in parts lists.

Reference Numbers Indicating Quantity

In an illustration, if a reference number indicates more than one part, the reference number has the form nX y. The n represents the quantity of the part, the X is the multiplication symbol, and the y represents the reference number.

For example, in an illustration, the reference number 2X 37 means that two of the parts identified by reference number 37 are indicated.

Contents

Twin Bag Assembly	4
Bag and Frame Assembly.....	6
Bagger Top Assembly No. 140-5096	8
Weight Assembly	10
Chute Assembly	12
Chute Assembly No. 139-3259	14

Twin Bag Assembly

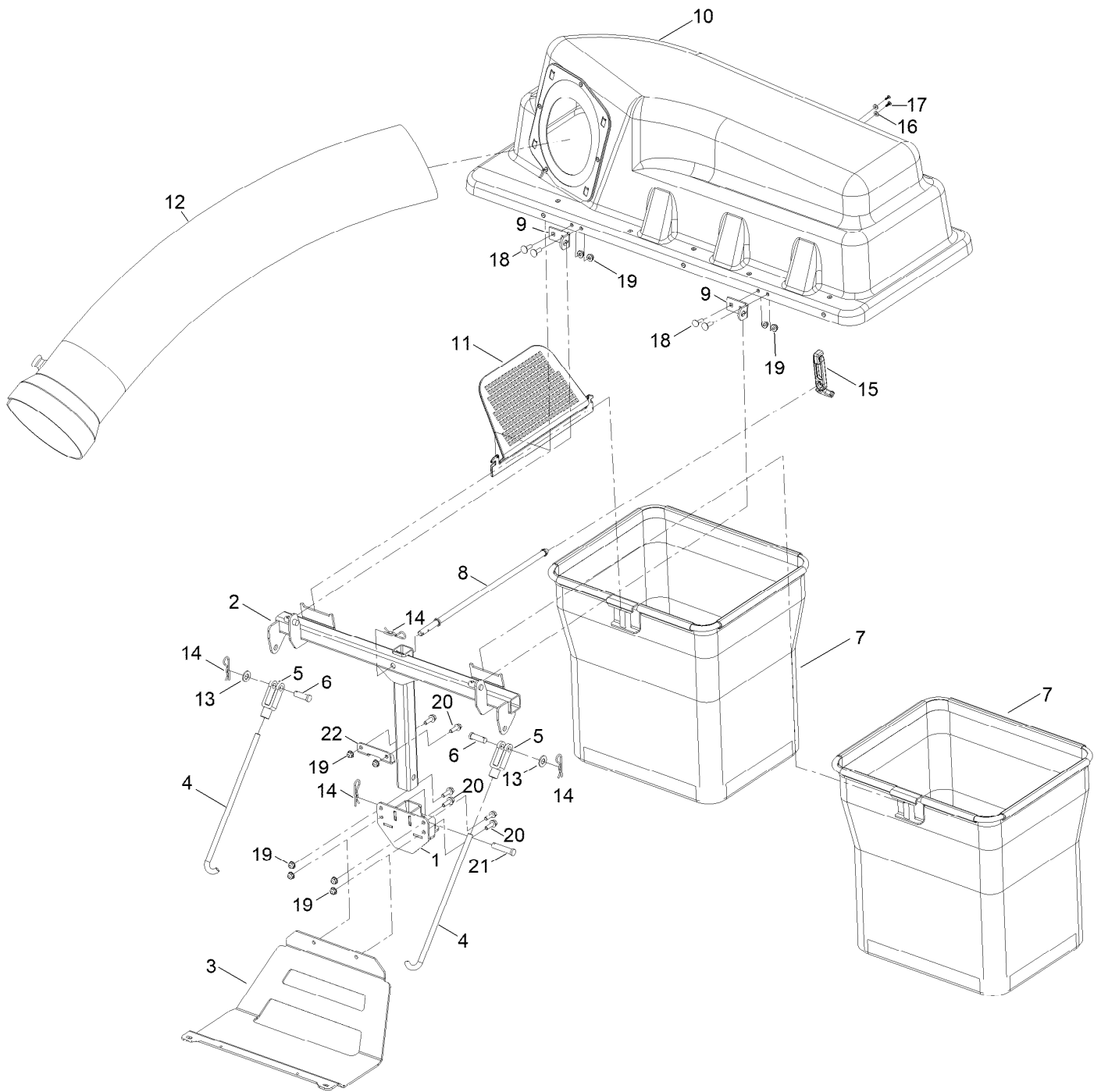

Twin Bag Assembly (continued)

<i>Ref.</i>	<i>Part Number</i>	<i>Qty.</i>	<i>Description</i>	<i>Ref.</i>	<i>Part Number</i>	<i>Qty.</i>	<i>Description</i>
1	147-8803-03	1	Mount-Bagger [black]	12	117-5379	1	Tube-Bagger
2	147-8820-03	1	Frame-Bagger [black]	13	139-2611	2	Washer-Flat
3	147-7716-03	1	Guard-Muffler [black]	14	139-2562	4	Pin-Hair
4	161-4479	2	Rod-Bagger Support	15	116-4992	1	Latch-Rubber
5	100-7338	2	Clevis	16	137-3073	2	Washer-Plain
6	283-68	2	Pin-Clevis	17	132-6919	2	Screw-Plastic, PTH
7	161-6239	2	Bag ASM	18	110-3144	4	Bolt-CARR
8	147-8819	1	Rod-Hold Down	19	119-4041	10	Nut-HF
9	140-5016	2	Bracket-Hopper Pivot	20	139-2596	6	Screw-HHF
10	140-5096	1	Top ASM-Bagger	21	92-2739	1	Pin-Clevis
11	112-3993	1	Screen-Bagger	22	147-8831-03	1	Plate-Bagger Stabilizer

Bag and Frame Assembly

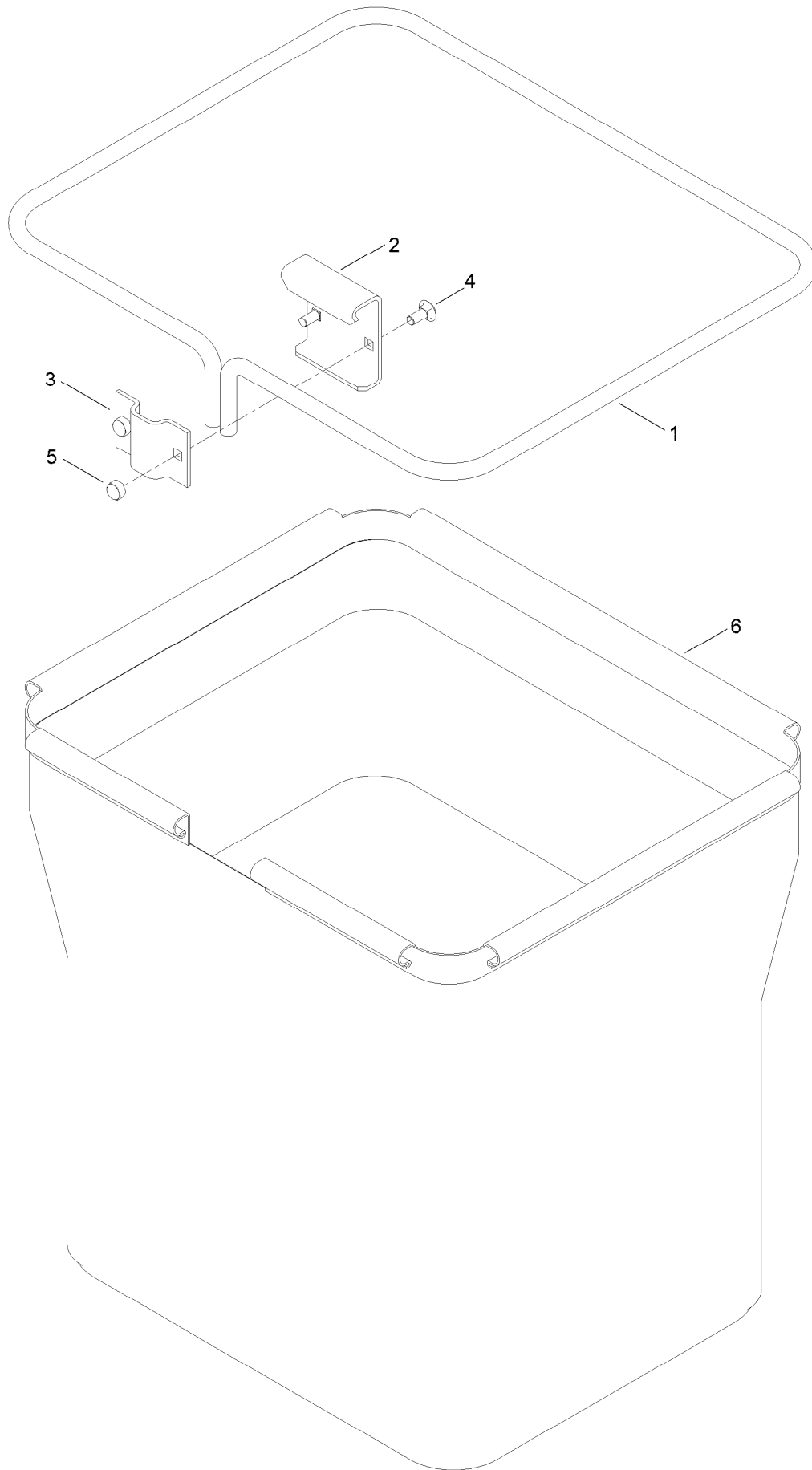

Bag and Frame Assembly (continued)

<i>Ref.</i>	<i>Part Number</i>	<i>Qty.</i>	<i>Description</i>	<i>Ref.</i>	<i>Part Number</i>	<i>Qty.</i>	<i>Description</i>
1	114972-03	1	Frame-Bag	4	139-2630	2	Bolt-CARR
2	114973-03	1	Hanger-Bag	5	119-4038	2	Nut-Hex
3	114974-03	1	Clamp	6	140-5192	1	Bag ASM 20In Depth

Bagger Top Assembly No. 140-5096

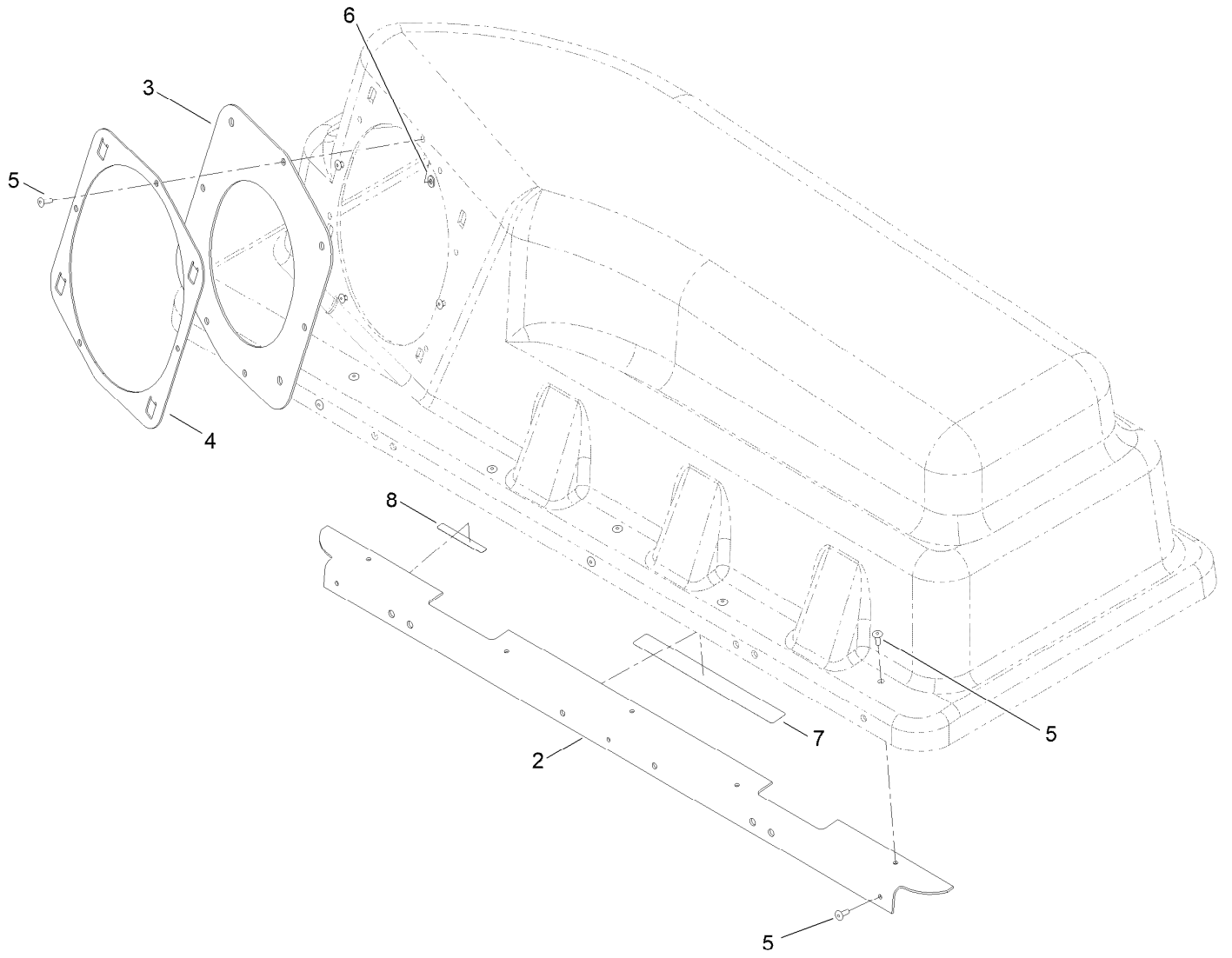

Bagger Top Assembly No. 140-5096 (continued)

<i>Ref.</i>	<i>Part Number</i>	<i>Qty.</i>	<i>Description</i>	<i>Ref.</i>	<i>Part Number</i>	<i>Qty.</i>	<i>Description</i>
2	116-1242-03	1	Stiffener-Bagger Top	6	137-3073	4	Washer-Plain
3	112-4001	1	Gasket	7	109-6809	1	Decal-Caution, Bagger
4	112-4000-03	1	Ring-Retainer	8	133-8061	1	Decal-Warning
5	114439	12	Rivet-Blind				

Weight Assembly

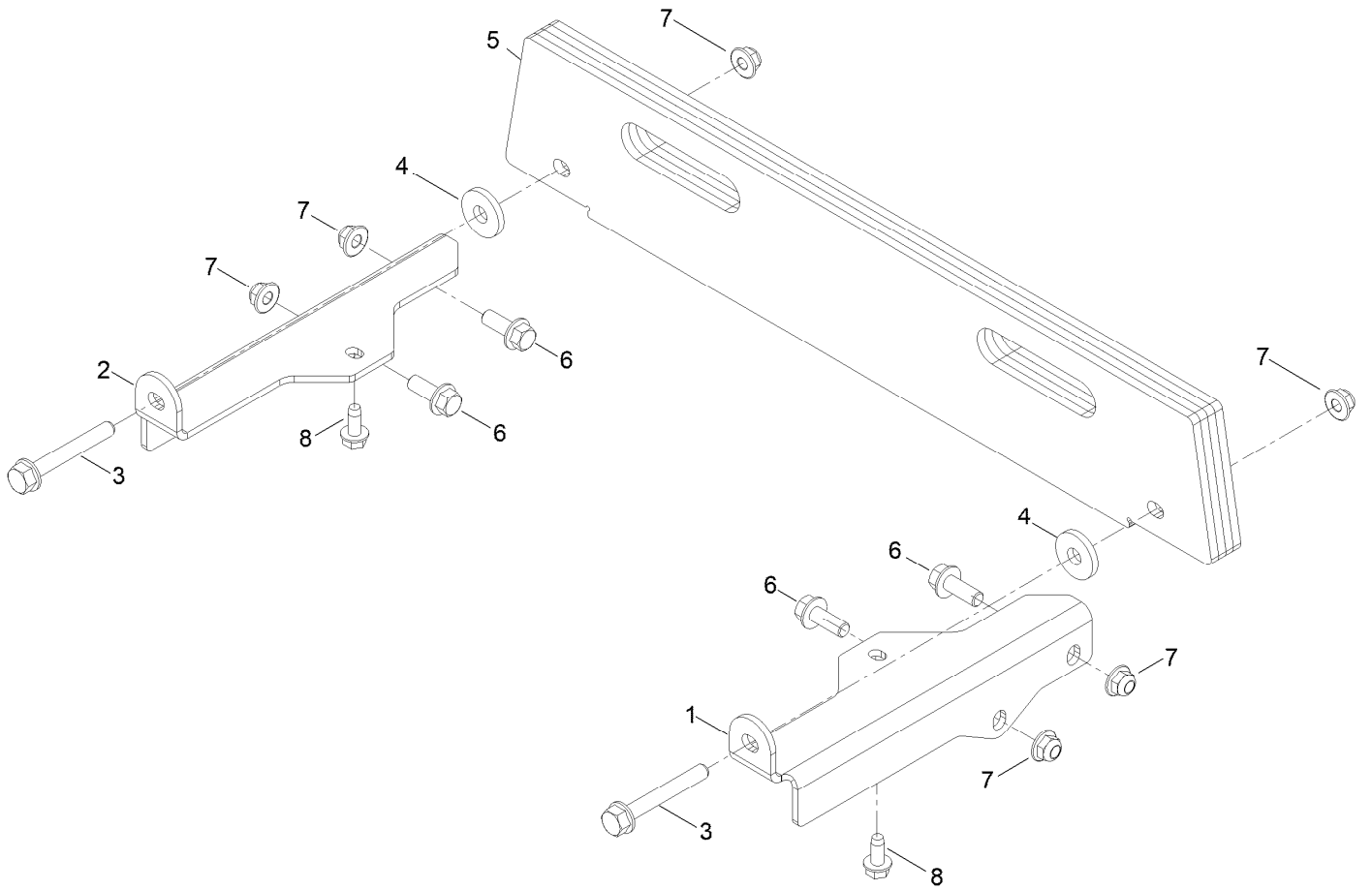

Weight Assembly (continued)

<i>Ref.</i>	<i>Part Number</i>	<i>Qty.</i>	<i>Description</i>	<i>Ref.</i>	<i>Part Number</i>	<i>Qty.</i>	<i>Description</i>
1	147-7581-03	1	Bracket-Weight Tc [black]	5	147-7582-03	4	Weight-Bagger
2	147-7583-03	1	Bracket-Weight Tc [black]	6	139-2597	4	Screw-HHF
3	140-5097	2	Screw-Spcl	7	119-4042	6	Nut-HF, NI
4	87-5330	2	Washer	8	32144-70	2	Screw-HWHTF

Chute Assembly

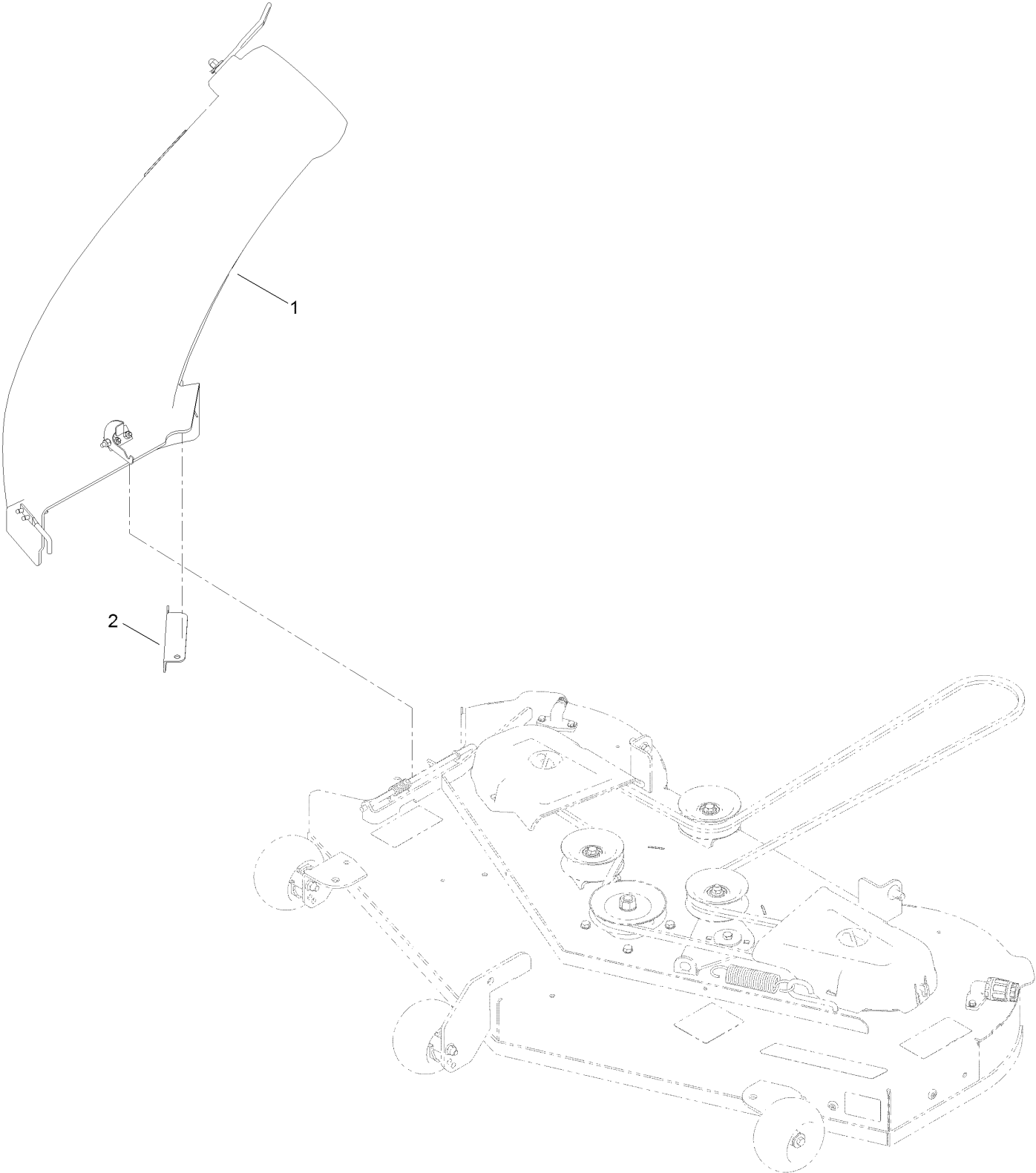

Chute Assembly (continued)

<i>Ref.</i>	<i>Part Number</i>	<i>Qty.</i>	<i>Description</i>
1	139-3259	1	50/54 Boot Assembly
2	140-3502-03	1	Baffle-Cutoff

Chute Assembly No. 139-3259

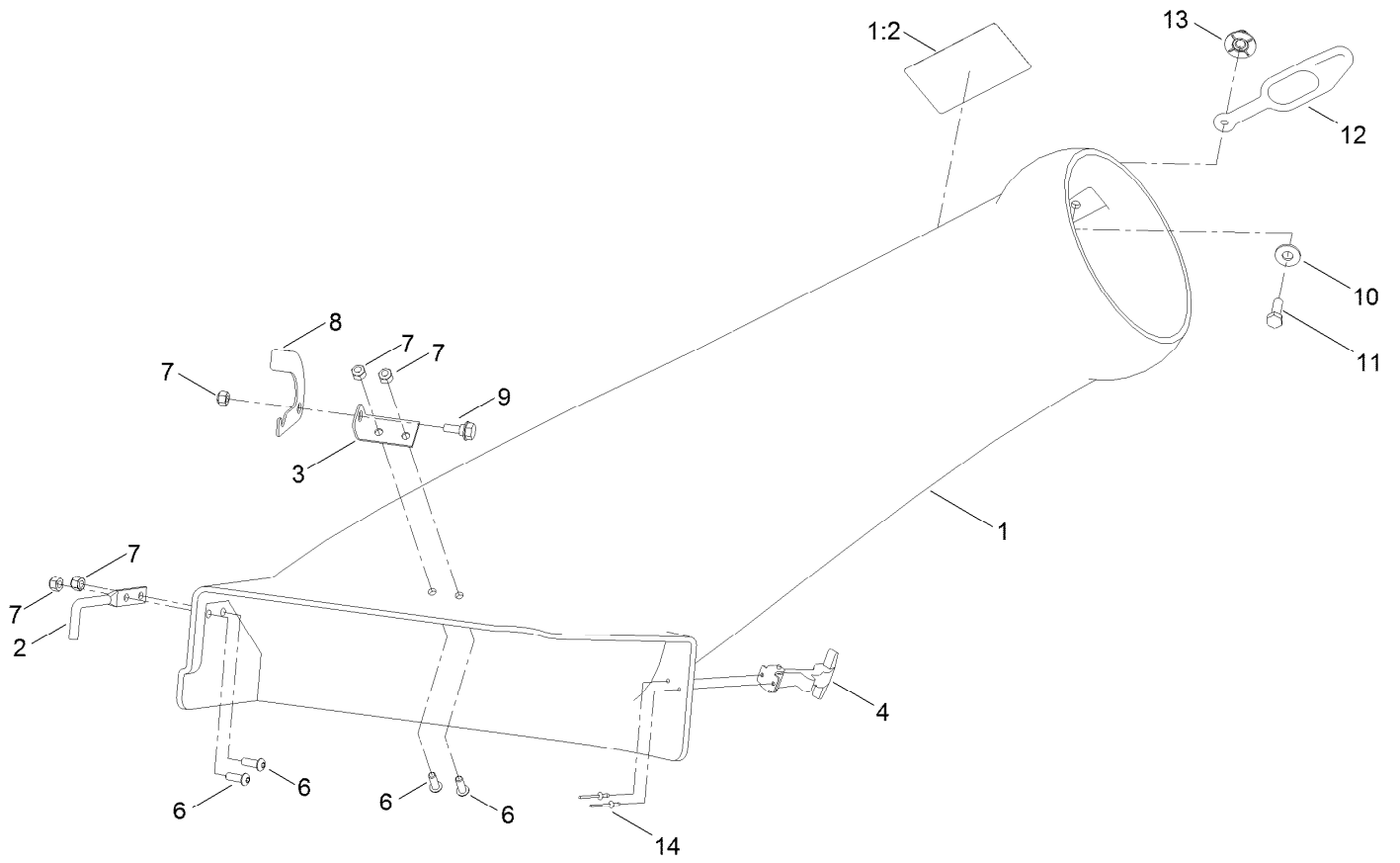

Chute Assembly No. 139-3259 (continued)

<i>Ref.</i>	<i>Part Number</i>	<i>Qty.</i>	<i>Description</i>
1	140-3465	1	50/54 Fab Bagger Boot
1:2	110-6691	1	Decal-Danger
2	138-7572	1	Hook-Boot
3	140-5094	1	Plate-Pivot, Cz
4	117344	1	Handle ASM
6	3274-69	4	Screw-HSBH
7	137-3088	5	Nut-Hex

<i>Ref.</i>	<i>Part Number</i>	<i>Qty.</i>	<i>Description</i>
8	138-7571	1	Plate-Latch
9	139-1730	1	Screw-Shoulder, HHF
10	139-1723	1	Washer-Flat
11	139-1716	1	Screw-HH
12	82-5690	1	Retainer-Duct
13	114-9015	1	Nut-Impeller
14	3269-31	2	Rivet-Pop

