



Count on it.

Operator's Manual

**Z Master® Professional 5000
Series Riding Mower**

**with 60in TURBO FORCE® Side Discharge
and Rear Discharge Mower**

Model No. 72910—Serial No. 400000000 and Up

Model No. 72911—Serial No. 400000000 and Up

Model No. 72912—Serial No. 400000000 and Up

Model No. 72921—Serial No. 400000000 and Up

Model No. 72922—Serial No. 400000000 and Up

Model No. 72923—Serial No. 400000000 and Up



It is a violation of California Public Resource Code Section 4442 or 4443 to use or operate the engine on any forest-covered, brush-covered, or grass-covered land unless the engine is equipped with a spark arrester, as defined in Section 4442, maintained in effective working order or the engine is constructed, equipped, and maintained for the prevention of fire.

The enclosed engine owner's manual is supplied for information regarding the US Environmental Protection Agency (EPA) and the California Emission Control Regulation of emission systems, maintenance, and warranty. Replacements may be ordered through the engine manufacturer.

Gross or Net Torque: The gross or net torque of this engine was laboratory rated by the engine manufacturer in accordance with the Society of Automotive Engineers (SAE) J1940 or J2723. As configured to meet safety, emission, and operating requirements, the actual engine torque on this class of mower will be significantly lower. Please refer to the engine manufacturer's information included with the machine.

⚠ WARNING

CALIFORNIA Proposition 65 Warning

The engine exhaust from this product contains chemicals known to the State of California to cause cancer, birth defects, or other reproductive harm.

Battery posts, terminals, and related accessories contain lead and lead compounds, chemicals known to the State of California to cause cancer and reproductive harm. Wash hands after handling.

Use of this product may cause exposure to chemicals known to the State of California to cause cancer, birth defects, or other reproductive harm.

Introduction

This rotary-blade, riding lawn mower is intended to be used by professional, hired operators. It is designed primarily for cutting grass on well-maintained lawns on residential or commercial properties. Using this product for purposes other than its intended use could prove dangerous to you and bystanders.

Read this information carefully to learn how to operate and maintain your product properly and to avoid injury and product damage. You are responsible for operating the product properly and safely.

Visit www.Toro.com for product safety and operation training materials, accessory information, help finding a dealer, or to register your product.

Whenever you need service, genuine Toro parts, or additional information, contact an Authorized Service Dealer or Toro Customer Service and have the model and serial numbers of your product ready. **Figure 1** identifies the location of the model and serial numbers on the product. Write the numbers in the space provided.

Important: With your mobile device, you can scan the QR code (if equipped) on the serial number decal to access warranty, parts, and other product information.

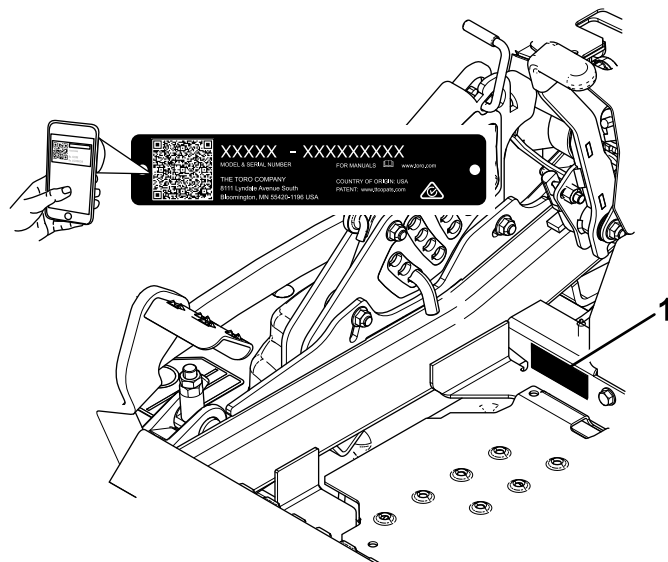

g233771

Figure 1

1. Model and serial number location

Model No. _____

Serial No. _____

This manual uses 2 words to highlight information. **Important** calls attention to special mechanical

information and **Note** emphasizes general information worthy of special attention.

The safety-alert symbol (Figure 2) appears both in this manual and on the machine to identify important safety messages that you must follow to avoid accidents. This symbol will appear with the word **Danger**, **Warning**, or **Caution**.

- **Danger** indicates an imminently hazardous situation which, if not avoided, **will** result in death or serious injury.
- **Warning** indicates a potentially hazardous situation which, if not avoided, **could** result in death or serious injury.
- **Caution** indicates a potentially hazardous situation which, if not avoided, **may** result in minor or moderate injury.



Figure 2

Safety-alert symbol

sa-black

Contents

Safety	5
General Safety	5
Slope Indicator	6
Safety and Instructional Decals	7
Product Overview	16
Controls	17
Hour Meter	17
Hour Meter	18
Specifications	19
Machines with Side Discharge	19
Machines with Rear Discharge	19
Attachments/Accessories	19
Before Operation	20
Before Operation Safety	20
Adding Fuel	21
Performing Daily Maintenance	21
Breaking in a New Machine	21
Using the Rollover-Protection System (ROPS)	22
Using the Safety-Interlock System	23
Positioning the Seat	24
Unlatching the Seat	24
Changing the Seat Suspension	24
During Operation	24
During Operation Safety	24
Operating the Parking Brake	27
Operating the Mower Blade-Control Switch (PTO)	27
Operating the Throttle	27
Starting the Engine	28
Shutting Off the Engine	28
Using the Motion-Control Levers	29
Driving the Machine	29
Using the Side Discharge	30
Adjusting the Height of Cut	31
Adjusting the Anti-Scalp Rollers	32
Adjusting the Skid(s)	33
Adjusting the Flow Baffle Knob	33
Positioning the Flow Baffle	34
Operating Tips	35
After Operation	36
After Operation Safety	36
Using the Fuel-Shutoff Valve	36
Using the Drive-Wheel-Release Valves	36
Transporting the Machine	37
Maintenance	39
Maintenance Safety	39
Recommended Maintenance Schedule(s)	39
Lubrication	41
Greasing the Machine	41
Lubricating the Mower Deck-Lift Pivots	41
Greasing the Mower Deck	41
Greasing the Caster Pivots	43
Greasing the Caster-Wheel Hubs	43
Engine Maintenance	44
Engine Safety	44

Identifying the Engine	44	Servicing the Cutting Blades	76
Servicing a Kawasaki® Engine	45	Leveling the Mower Deck	79
Servicing a Kohler® Engine	50	Removing the Mower Deck	82
Checking the Spark Arrester	55	Replacing the Grass Deflector	84
Fuel System Maintenance	55	Cleaning	85
Servicing the Electronic Fuel-Injection System	55	Cleaning under the Mower Deck	85
Replacing the Low-Pressure Fuel Filter	55	Disposing of Waste	85
Servicing the High-Pressure Fuel Filter	56	Storage	86
Servicing the Fuel Tank	56	Storage Safety	86
Electrical System Maintenance	56	Cleaning and Storage	86
Electrical System Safety	56	Troubleshooting	87
Servicing the Battery	56	Schematics	90
Servicing the Fuses	58		
Servicing the Fuses	59		
Jump-Starting the Machine	59		
Drive System Maintenance	60		
Checking the Seat Belt	60		
Checking the Roll-Bar Knobs	60		
Adjusting the Tracking	61		
Checking the Tire Pressure	62		
Checking the Wheel Lug Nuts	62		
Checking the Wheel-Hub Slotted Nut	62		
Adjusting the Caster-Pivot Bearing	62		
Removing the Clutch Shim	63		
Cooling System Maintenance	65		
Cooling System Safety	65		
Cleaning the Engine Screen and Engine-Oil Cooler	65		
Cleaning the Engine-Cooling Fins and Shrouds	65		
Checking and Cleaning the Hydraulic-Unit Shrouds	66		
Brake Maintenance	66		
Adjusting the Parking Brake	66		
Belt Maintenance	67		
Inspecting the Belts	67		
Replacing the Mower Belt for Side-Discharge Mower Decks	67		
Replacing the Mower Belt for Rear-Discharge Mower Decks	68		
Replacing the Hydraulic Pump-Drive Belt	70		
Controls System Maintenance	71		
Adjusting the Control-Handle Position	71		
Adjusting the Motion-Control Linkage	71		
Adjusting the Motion-Control Damper	72		
Adjusting the Motion-Control Neutral-Lock Pivot	73		
Hydraulic System Maintenance	73		
Hydraulic System Safety	73		
Hydraulic-Fluid Specifications	73		
Checking the Hydraulic Fluid	73		
Changing the Hydraulic Fluid and Filters	74		
Mower Deck Maintenance	76		
Blade Safety	76		

Safety

General Safety

This product is capable of amputating hands and feet and of throwing objects. Always follow all safety instructions to avoid serious personal injury.

- Read and understand the contents of this *Operator's Manual* before starting the engine.
- Keep bystanders and children away.
- Do not allow children or untrained people to operate or service the machine. Allow only people who are responsible, trained, familiar with the instructions, and physically capable to operate or service the machine.
- Always keep the roll bar in the fully raised and locked position and use the seat belt.
- Do not operate the machine near drop-offs, ditches, embankments, water, or other hazards, or on slopes greater than 15°.
- Do not put your hands or feet near moving components of the machine.
- Do not operate the machine without all guards, safety switches, and other safety protective devices in place and functioning properly.
- Shut off the engine, remove the key, and wait for all moving parts to stop before leaving the operator's position. Allow the machine to cool before servicing, adjusting, fueling, cleaning, or storing it.

Slope Indicator

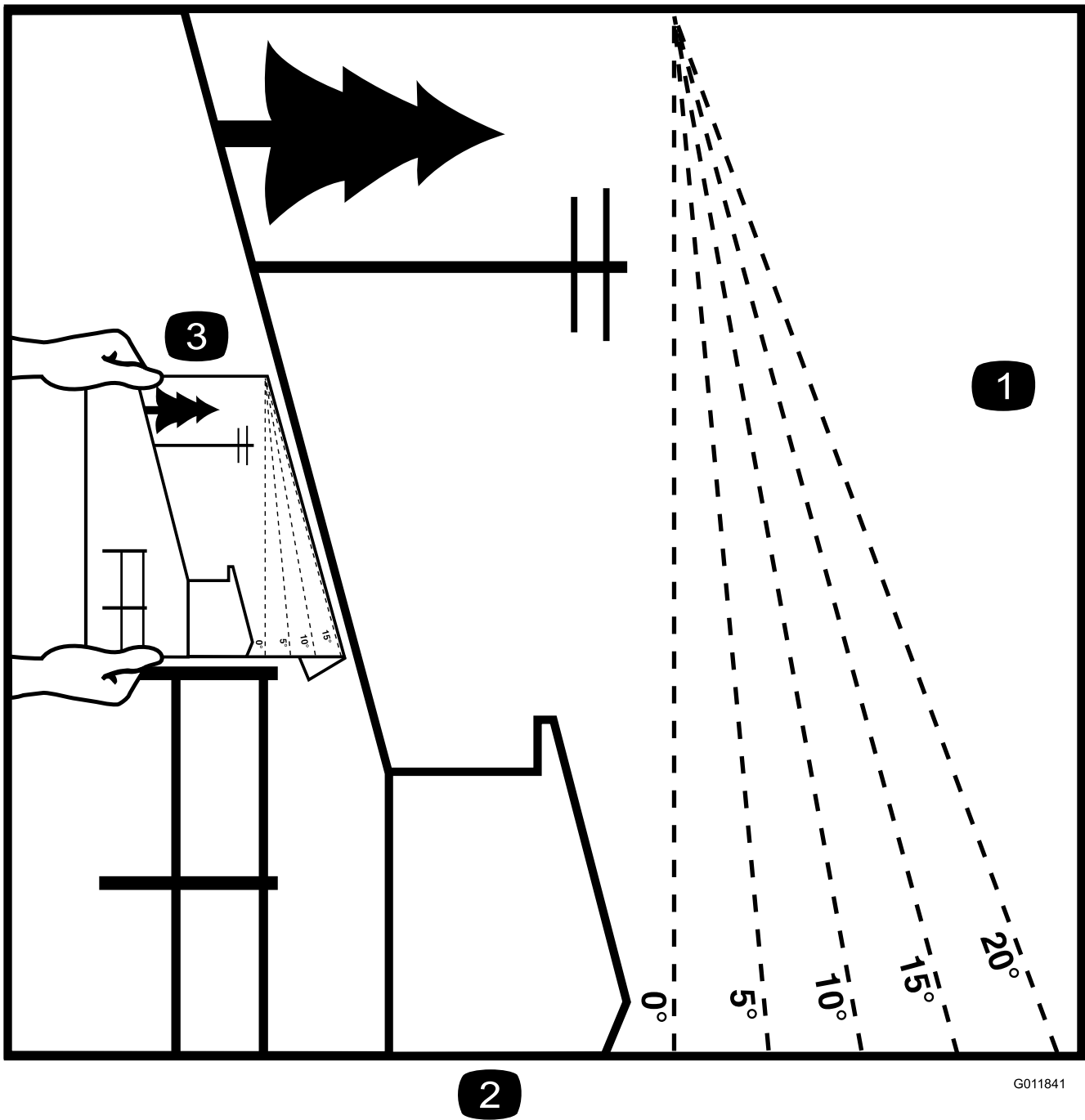

G011841

g011841

Figure 3

You may copy this page for personal use.

1. The maximum slope you can operate the machine on is **15 degrees**. Use the slope chart to determine the degree of slope of hills before operating. **Do not operate this machine on a slope greater than 15 degrees**. Fold along the appropriate line to match the recommended slope.
2. Align this edge with a vertical surface, a tree, building, fence pole, etc.
3. Example of how to compare slope with folded edge

Safety and Instructional Decals



Safety decals and instructions are easily visible to the operator and are located near any area of potential danger. Replace any decal that is damaged or missing.



Battery Symbols

Some or all of these symbols are on your battery.

- | | |
|--|---|
| 1. Explosion hazard | 6. Keep bystanders away from the battery. |
| 2. No fire, open flame, or smoking | 7. Wear eye protection; explosive gases can cause blindness and other injuries. |
| 3. Caustic liquid/chemical burn hazard | 8. Battery acid can cause blindness or severe burns. |
| 4. Wear eye protection. | 9. Flush eyes immediately with water and get medical help fast. |
| 5. Read the <i>Operator's Manual</i> . | 10. Contains lead; do not discard |

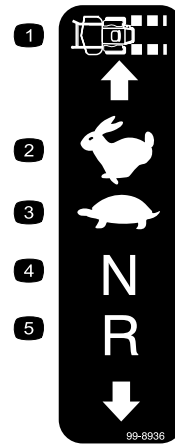

99-8936

decal99-8936

- | | |
|------------------|------------|
| 1. Machine speed | 4. Neutral |
| 2. Fast | 5. Reverse |
| 3. Slow | |



decaloemmark

Manufacturer's Mark

- This mark indicates that the blade is identified as a part from the original machine manufacturer.

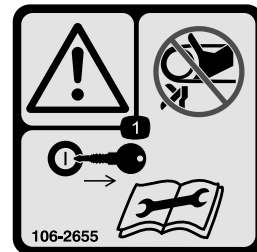

106-2655

decal106-2655

106-2655

- Warning—do not touch or approach moving belts; remove the key and read the instructions before servicing or performing maintenance.



decal58-6520

58-6520

- Grease



106-5517

decal106-5517

106-5517

- Warning—do not touch the hot surface.

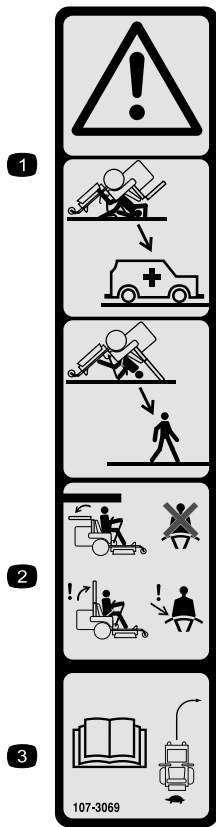

107-3069

decal107-3069

1. Warning—there is no rollover protection when the roll bar is down.
2. To avoid injury or death from a rollover accident, keep the roll bar in the fully raised and locked position and wear the seat belt. Lower the roll bar only when absolutely necessary; do not wear the seat belt when the roll bar is down.
3. Read the *Operator's Manual*; drive slowly and carefully.

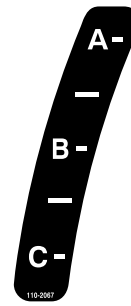

110-2067

decal110-2067

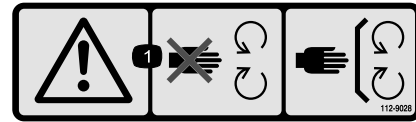

112-9028

decal112-9028

1. Warning—stay away from moving parts; keep all guards and shields in place.

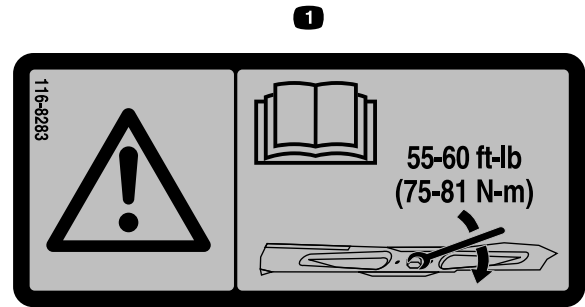

116-8283

decal116-8283

1. Warning—read the *Operator's Manual* for instructions on torquing the blade bolt/nut to 75 to 81 N·m (55 to 60 ft-lb).

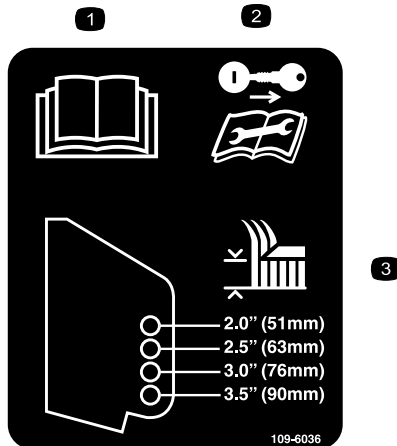

109-6036

decal109-6036

Rear Discharge Machines Only

1. Read the *Operator's Manual*.
2. Remove the key and read the instructions before servicing or performing maintenance.
3. Height of cut



133-8062

decal133-8062

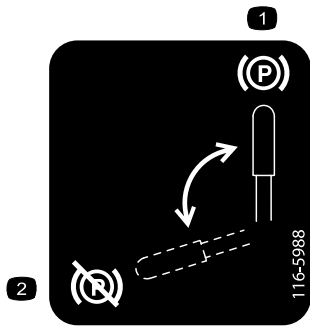

116-5988

decal116-5988

1. Parking brake—engaged
2. Parking brake—disengaged



116-8726

decal116-8726

1. Read the *Operator's Manual* for the recommended hydraulic fluid.



117-3848

decal117-3848

1. Thrown object hazard—keep bystanders away.
2. Thrown object hazard, raised deflector—do not operate without the deflector, discharge cover, or grass collection system in place.
3. Cutting/dismemberment hazard of hand or foot, mower blade—stay away from moving parts; keep all guards and shields in place.

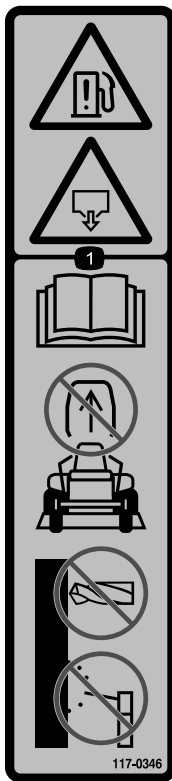

117-0346

decal117-0346

1. Fuel leak hazard—read the *Operator's Manual*; do not attempt to remove the roll bar; do not weld, drill or modify the roll bar in any way.

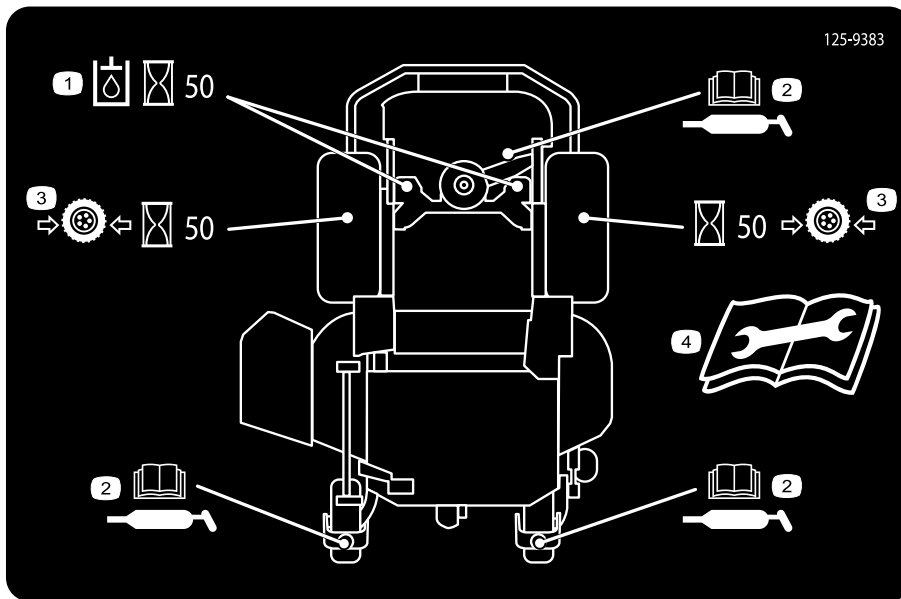

125-9383

125-9383

decal125-9383

1. Check hydraulic fluid every 50 operating hours.
2. Read the *Operator's Manual* for information on lubricating the machine.
3. Check the tire pressure every 50 operating hours.
4. Read the *Operator's Manual* before servicing or performing maintenance.



decal126-2055

126-2055

1. Wheel lug nut—torque to 129 N·m (95 ft-lb).
2. Wheel hub nut—torque to 319 N·m (235 ft-lb).
3. Read the *Operator's Manual* before performing maintenance; check the torque after the first 100 hours and every 500 hours after.

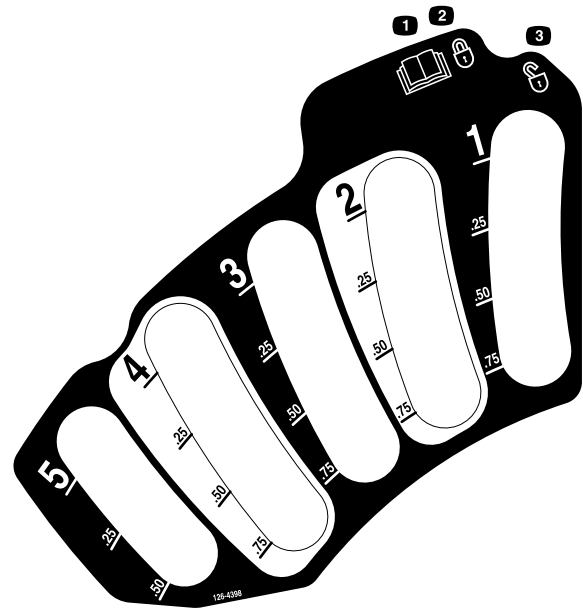

126-4398

decal126-4398

1. Read the *Operator's Manual*.
2. Lock
3. Unlock



126-4659

126-4659

decal126-4659

1. Warning—hot pulley; allow to cool.

Machines with a standard hour meter only

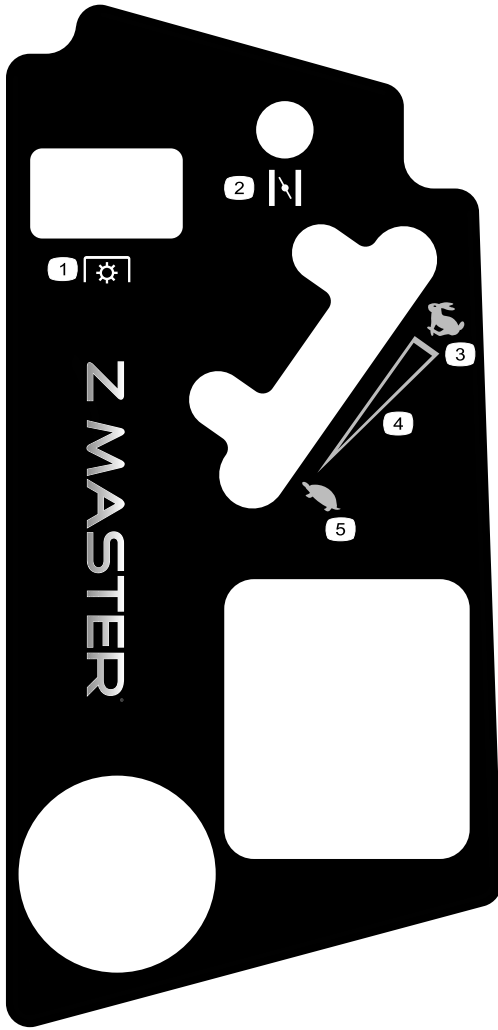

121-7551

decal121-7551

- | | |
|------------------------|--------------------------------|
| 1. Power takeoff (PTO) | 4. Continuous variable setting |
| 2. Choke | 5. Slow |
| 3. Fast | |

Machines with a smart hour meter only

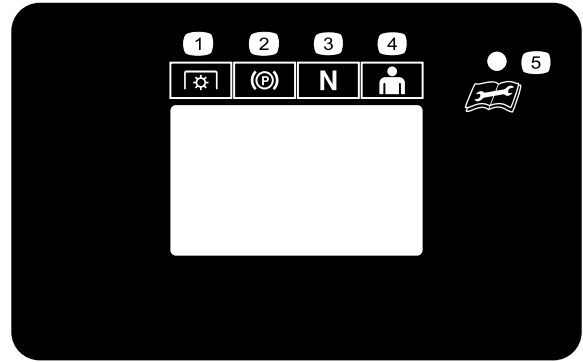

g224114

126-5641

- | | |
|------------------|--|
| 1. PTO | 4. Operator-presence switch |
| 2. Parking brake | 5. See user's guide for operating condition code |
| 3. Neutral | |

Machines with a Kawasaki Engine Only

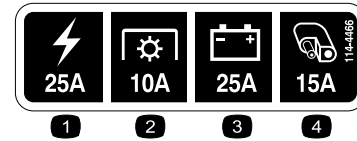

decal114-4466

114-4466

- | | |
|--------------|-------------------|
| 1. Main, 25A | 3. Charge, 25A |
| 2. PTO, 10A | 4. Auxiliary, 15A |

Machines with a Kohler Engine Only

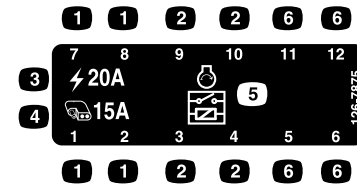

decal126-7875

126-7875

- | | |
|-------------------|-------------------|
| 1. Fuse location | 4. Auxiliary, 15A |
| 2. Relay location | 5. Start relay |
| 3. Main, 20A | 6. Not used |

Machines with Side Discharge Only

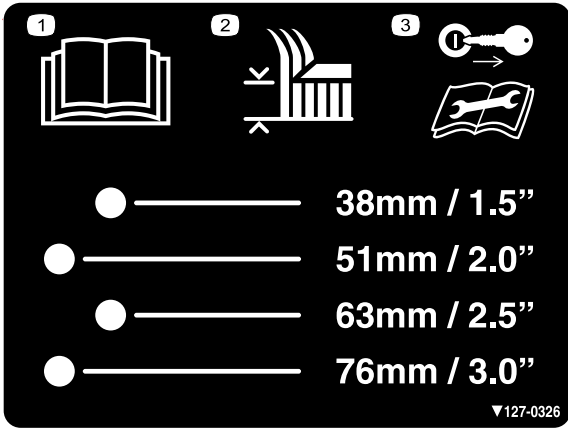

127-0326

decal127-0326

1. Read the *Operator's Manual*.
2. Height of cut
3. Remove the key and read the *Operator's Manual* before performing maintenance.

Machines with Rear Discharge Only

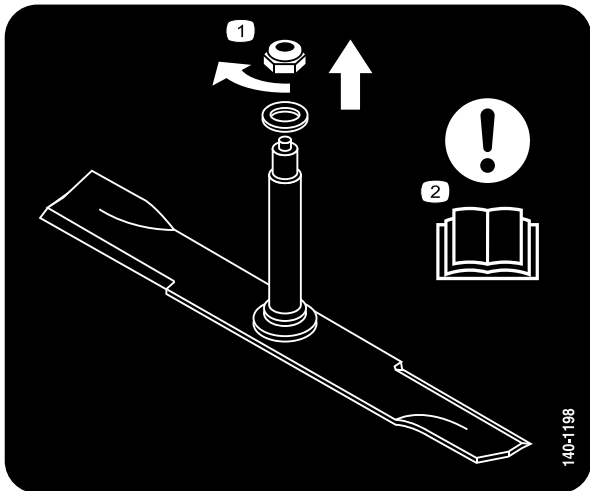

140-1198

decal140-1198

1. Rotate the nut clockwise to remove.
2. Attention—read the *Operator's Manual*.

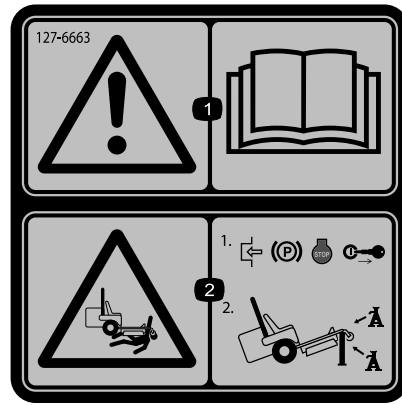

127-6663

decal127-6663

1. Warning—read the *Operator's Manual*.
2. Crushing hazard—engage the parking brake, shut off the engine, and remove the key; support the machine using jackstands.

Machines with a standard hour meter only

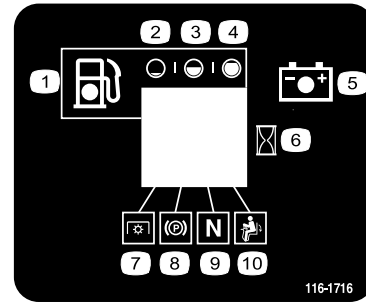

116-1716

decal116-1716

1. Fuel
2. Empty
3. Half
4. Full
5. Battery
6. Hour meter
7. PTO
8. Parking brake
9. Neutral
10. Operator presence switch

Machines with Side Discharge Only

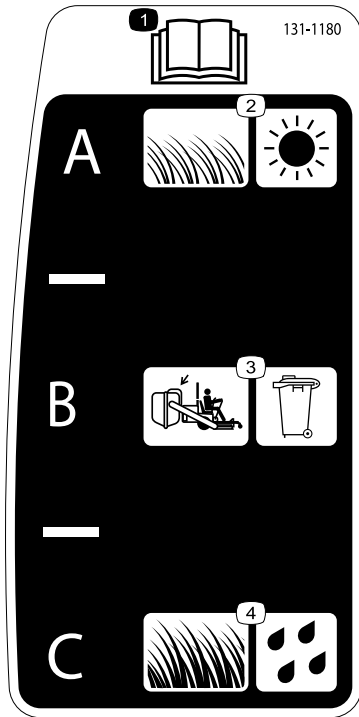

131-1180

decal131-1180

1. Read the *Operator's Manual*.
2. Short, light grass; dry conditions
3. Bagging setting
4. Tall, dense grass; wet conditions

Machines with Side Discharge Only

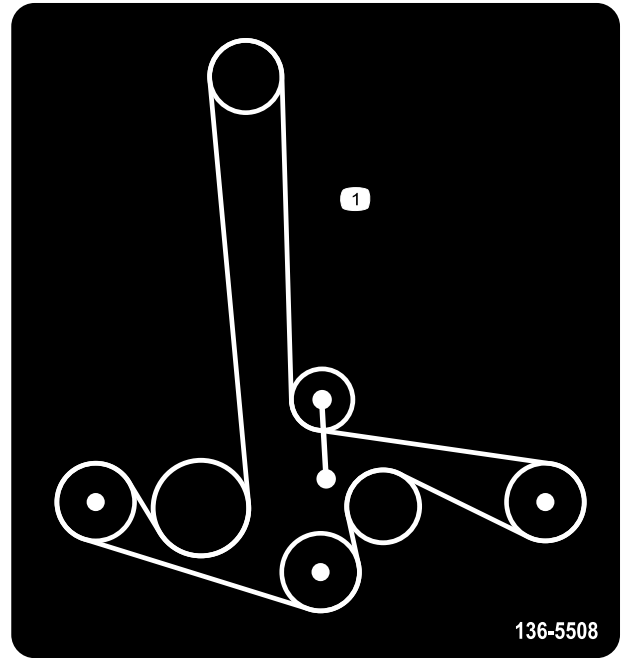

decal136-5508

136-5508

1. Belt routing

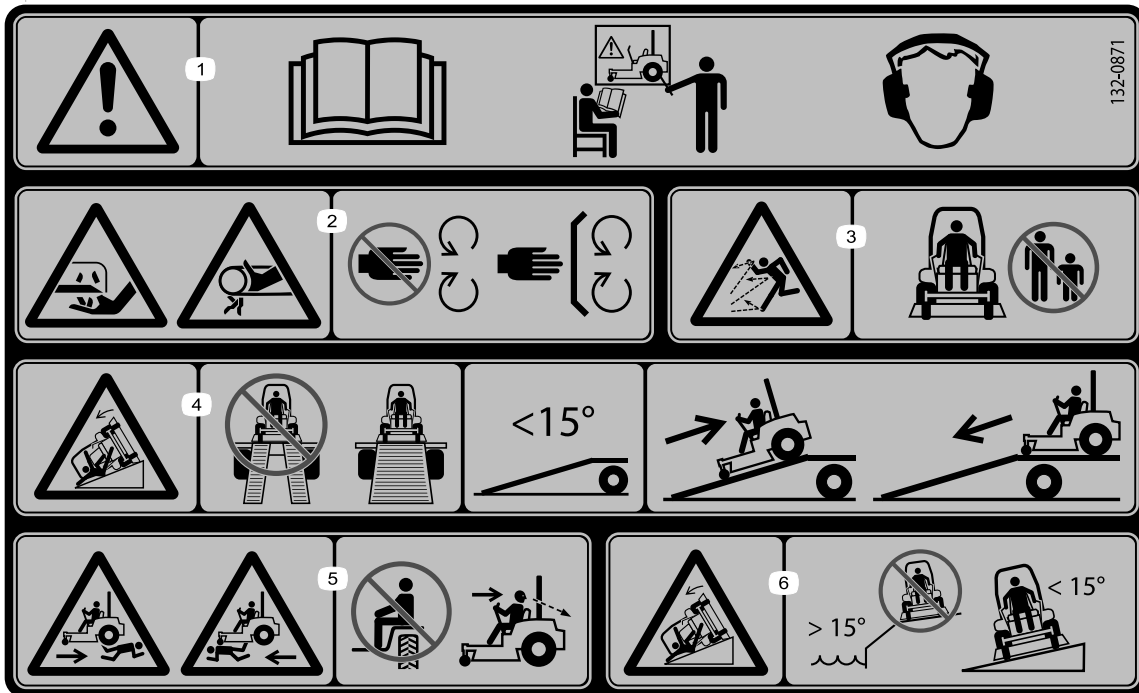

132-0871

decal132-0871

Note: This machine complies with the industry standard stability test in the static lateral and longitudinal tests with the maximum recommended slope indicated on the decal. Review the instructions for operating the machine on slopes in the *Operator's Manual* as well as the conditions in which you would operate the machine to determine whether you can operate the machine in the conditions on that day and at that site. Changes in the terrain can result in a change in slope operation for the machine.

1. Warning—read the *Operator's Manual*; all operators should be trained before operating the machine; wear hearing protection.
2. Cutting/dismemberment hazard of hand—stay away from moving parts; keep all guards and shields in place.
3. Thrown object hazard—keep bystanders away.
4. Tipping hazard—do not use dual ramps when loading onto a trailer; use 1 ramp wide enough for the machine; use a ramp with a slope less than 15° ; back up the ramp (in reverse) and drive forward off the ramp.
5. Runover hazard—do not carry passengers; look behind you when moving in reverse.
6. Tipping hazard—do not use the machine near drop-offs or on slopes greater than 15° ; only operate across slopes less than 15° .

Machines with a smart hour meter only

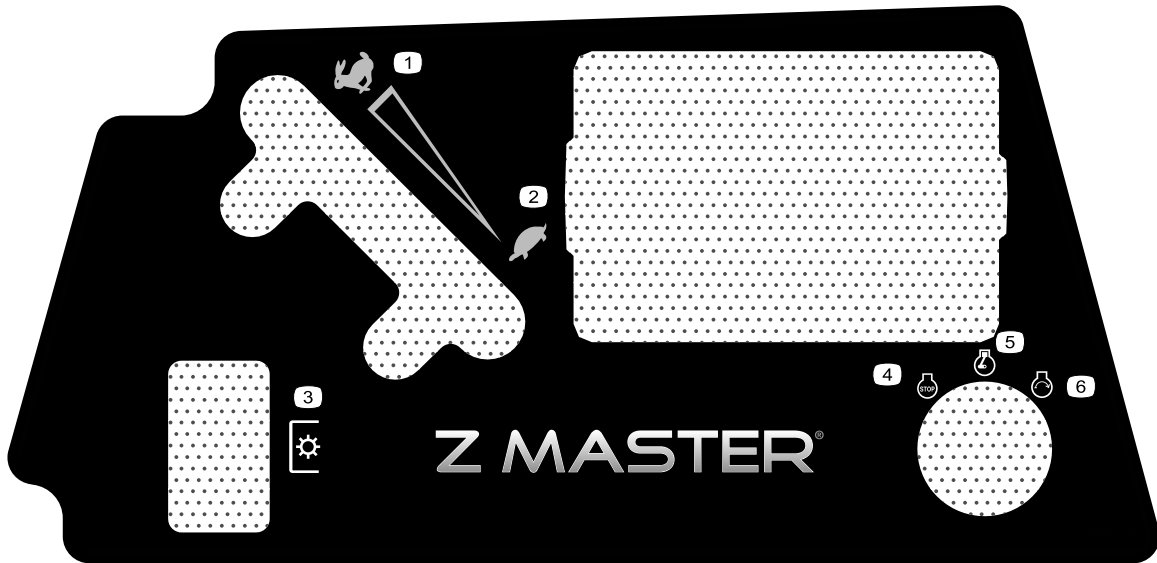

decal137-9208

137-9208

- | | |
|---------|-----------------|
| 1. Fast | 4. Engine—stop |
| 2. Slow | 5. Engine—run |
| 3. PTO | 6. Engine—start |

Machines with Rear Discharge Only

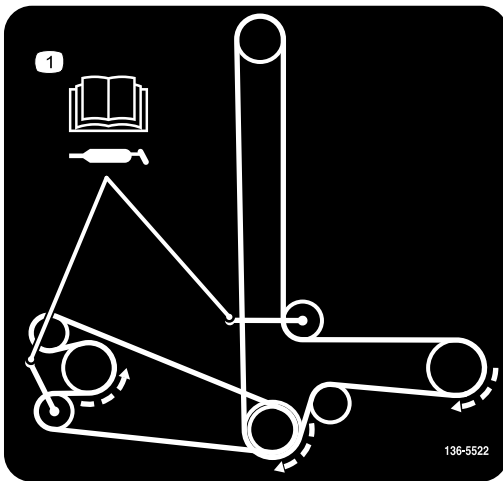

decal136-5522

136-5522

1. Belt routing; read the *Operator's Manual* for greasing information.

Product Overview

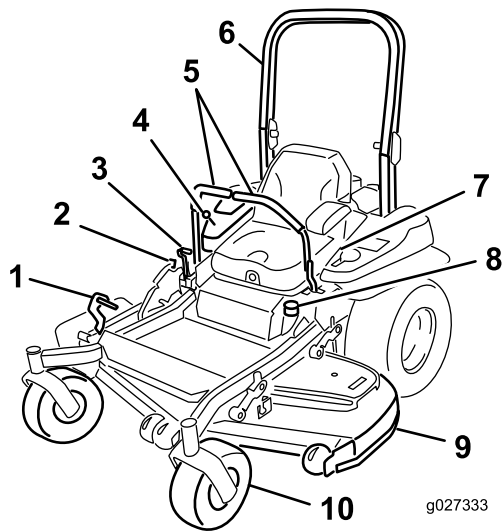

Figure 4

Side-Discharge Machine Shown

- | | |
|--------------------------|------------------|
| 1. Deck-lift pedal | 6. Roll bar |
| 2. Transport lock | 7. Seat belt |
| 3. Parking-brake lever | 8. Fuel cap |
| 4. Controls | 9. Mower deck |
| 5. Motion-control levers | 10. Caster wheel |

g027333

Controls

Become familiar with all the controls before you start the engine and operate the machine.

Control Panel

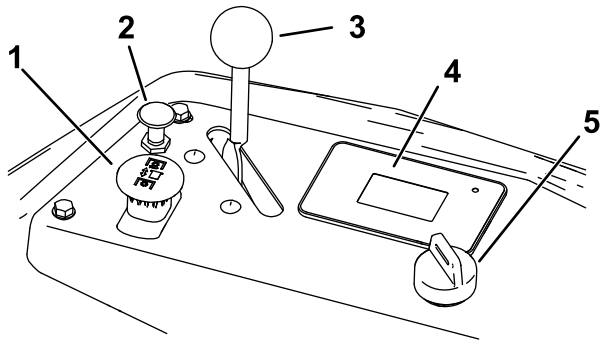

Figure 5

g233557

- | | |
|---|--|
| 1. Blade-control switch (power takeoff) | 4. Hour meter/Safety-interlock display |
| 2. Choke control | 5. Key switch |
| 3. Throttle control | |

Key Switch

The key switch, used to start and shut off the engine, has 3 positions: OFF, RUN, and START. Refer to [Starting the Engine \(page 28\)](#).

Throttle Control

The throttle controls the engine speed, and it has a continuous-variable setting from the SLOW to FAST position ([Figure 5](#)).

Choke Control

Use the choke control to start a cold engine.

Blade-Control Switch (Power Takeoff)

The blade-control switch, represented by a power-takeoff (PTO) symbol, engages and disengages power to the mower blades ([Figure 5](#)).

Hour Meter

Machines with a Standard Hour Meter

The hour meter records the number of hours the engine has operated. It operates when the engine is running. Use these times for scheduling regular maintenance ([Figure 6](#)).

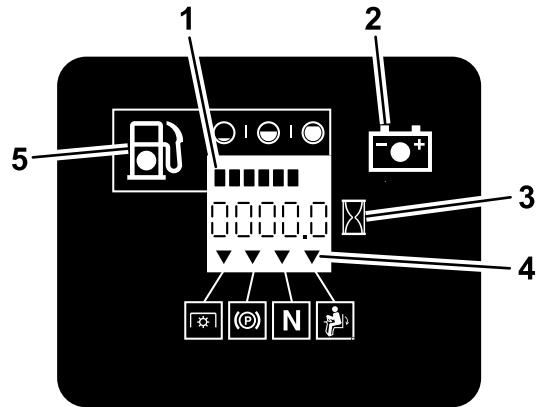

G008950

g008950

Figure 6

- | | |
|----------------------|-----------------------------|
| 1. Fuel gauge (bars) | 4. Safety-interlock symbols |
| 2. Battery light | 5. Low fuel indicator light |
| 3. Hour meter | |

Fuel Gauge

The fuel gauge is located within the hour meter, and the bars light up when the key switch is in the ON position ([Figure 6](#)).

The indicator light appears when the fuel level is low (approximately 1 gallon remaining in the fuel tank).

Safety-Interlock Indicators

There are symbols on the hour meter that indicate with a black triangle that the interlock component is positioned correctly ([Figure 7](#)).

Battery-Indicator Light

If you turn the key switch to the ON position for a few seconds, the battery voltage displays in the area where the hours are normally displayed.

The battery light turns on when the key switch is turned on and when the charge is below the correct operating level ([Figure 6](#)).

Electronic-Control Unit Malfunction-Indicator Light

The electronic-control unit (ECU) continuously monitors the operation of the EFI system.

If a problem or fault within the system is detected, the malfunction-indicator light (MIL) illuminates.

The MIL is the red light located in the right console panel.

Once the MIL illuminates, make initial troubleshooting checks; refer to the MIL section under [Troubleshooting \(page 87\)](#).

If these checks do not correct the problem, further diagnosis and servicing by an Authorized Service Dealer is necessary.

Hour Meter

For Machines with a Smart Hour Meter

The hour meter records the number of hours the engine has operated. It operates when the engine is running. Use these times for scheduling regular maintenance ([Figure 7](#)).

The hour meter displays when you are operating the machine and momentarily when you shut off the engine. The display turns off after 5 minutes.

Refer to the *Software Guide* for more information.

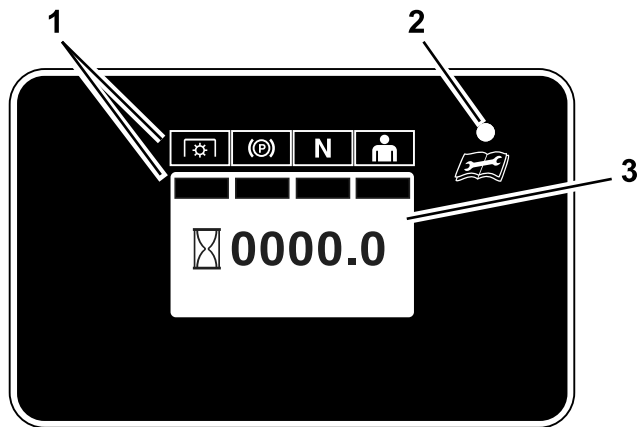

Figure 7

g231075

1. Safety-interlock indicators
2. LED status light
3. Information screen

LED Status Light

The LED is multi-colored to indicate the system status and is located on the right side of the panel.

- **Solid Green**—indicates normal operating activity.
- **Blinking Red**—indicates a fault is active.
- **Blinking Green and Orange**—indicates a clutch reset is required.
- **Solid Red**—indicates maintenance is required.

Refer to the *Software Guide* for more information.

Fuel Gauge

When the fuel-tank level is low, the LED status light flashes a red light and the fuel-level symbol on the screen flashes.

Refer to the *Software Guide* for more information.

Safety-Interlock Indicators

There are symbols on the hour meter that indicate with a black bar that the interlock component is positioned correctly ([Figure 7](#)).

Motion-Control Levers

Use the motion-control levers to drive the machine forward, reverse, and turn either direction ([Figure 4](#)).

Neutral-Lock Position

Move the motion-control levers outward from the center to the NEUTRAL-LOCK position when exiting the machine ([Figure 24](#)). Always position the motion-control levers into the NEUTRAL-LOCK position when you stop the machine or leave it unattended.

Parking-Brake Lever

Whenever you shut off the engine, engage the parking brake to prevent accidental movement of the machine.

Fuel-Shutoff Valve

Close the fuel-shutoff valve when transporting or storing the machine; refer to [Using the Fuel-Shutoff Valve \(page 36\)](#).

Specifications

Note: Specifications and design are subject to change without notice.

Machines with Side Discharge

Width:

	60-inch Deck	72-inch Deck
Without Deck	135 cm (53 inches)	150 cm (59 inches)
Deflector Up	157 cm (62 inches)	187 cm (74 inches)
Deflector Down	192 cm (76 inches)	222 cm (88 inches)

Length:

	60-inch Deck	72-inch Deck
Roll Bar—Up	211 cm (83 inches)	219 cm (86 inches)
Roll Bar—Down	215 cm (85 inches)	223 cm (88 inches)

Height:

Roll Bar—Up	Roll Bar—Down
179.1 cm (70.5 inches)	118.9 cm (46.8 inches)

Weight:

Model	Weight
60-inch Mower Deck	569 kg (1,255 lb)
72-inch Mower Deck	612 kg (1,350 lb)

Machines with Rear Discharge

Width:

	60-inch Mower Deck	72-inch Mower Deck
Without Mower Deck	134.6 cm (53.0 inches)	150.1 cm (59.1 inches)
With Mower Deck	168.4 cm (66.3 inches)	199.0 cm (78.3 inches)

Length:

	60-inch Mower Deck	72-inch Mower Deck
Roll Bar - Up	221.6 cm (87.25 inches)	221.6 cm (87.25 inches)
Roll Bar - Down	226.0 cm (88.95 inches)	226.0 cm (88.95 inches)

Height:

Roll Bar - Up	Roll Bar - Down
179.1 cm (70.5 inches)	118.9 cm (46.8 inches)

Weight:

Model	Weight
60-inch Mower Deck	577 kg (1,271 lb)
72-inch Mower Deck	606 kg (1,335 lb)

Attachments/Accessories

A selection of Toro approved attachments and accessories is available for use with the machine to enhance and expand its capabilities. Contact your Authorized Service Dealer or authorized Toro distributor or go to www.Toro.com for a list of all approved attachments and accessories.

To ensure optimum performance and continued safety certification of the machine, use only genuine Toro replacement parts and accessories. Replacement parts and accessories made by other manufacturers could be dangerous, and such use could void the product warranty.

Operation

Note: Determine the left and right sides of the machine from the normal operating position.

Before Operation

Before Operation Safety

General Safety

- Do not allow children or untrained people to operate or service the machine. Local regulations may restrict the age of the operator. The owner is responsible for training all operators and mechanics.
 - Inspect the area where you will use the machine, and remove all objects that could interfere with the operation of the machine or that the machine could throw.
 - Become familiar with the safe operation of the equipment, operator controls, and safety signs.
 - Check that operator-presence controls, safety switches, and guards are attached and working properly. Do not operate the machine unless they are functioning properly.
 - Shut off the engine, remove the key, and wait for all moving parts to stop before leaving the operator's position. Allow the machine to cool before servicing, adjusting, fueling, cleaning, or storing it.
 - Before mowing, inspect the machine to ensure that the cutting assemblies are working properly.
 - Evaluate the terrain to determine the appropriate equipment and any attachments or accessories required to operate the machine properly and safely.
 - Wear appropriate clothing, including eye protection; long pants; substantial, slip-resistant footwear; and hearing protection. Tie back long hair and do not wear loose clothing or loose jewelry.
 - Do not carry passengers on the machine.
 - Keep bystanders and pets away from the machine during operation. Shut off the machine and attachment(s) if anyone enters the area.
 - Do not operate the machine unless all guards and safety devices, such as the deflectors and the entire grass catcher, are in place and functioning properly. Replace worn or deteriorated parts when necessary.
- ## Fuel Safety
- Fuel is extremely flammable and highly explosive. A fire or explosion from fuel can burn you and others and can damage property.
 - To prevent a static charge from igniting the fuel, place the container and/or machine directly on the ground before filling, not in a vehicle or on an object.
 - Fill the fuel tank outdoors on level ground, in an open area, and when the engine is cold. Wipe up any fuel that spills.
 - Do not handle fuel when smoking or around an open flame or sparks.
 - Do not remove the fuel cap or add fuel to the tank while the engine is running or hot.
 - If you spill fuel, do not attempt to start the engine. Avoid creating a source of ignition until the fuel vapors have dissipated.
 - Store fuel in an approved container and keep it out of the reach of children.
 - Fuel is harmful or fatal if swallowed. Long-term exposure to vapors can cause serious injury and illness.
 - Avoid prolonged breathing of vapors.
 - Keep your hands and face away from the nozzle and the fuel-tank opening.
 - Keep fuel away from your eyes and skin.
 - Do not store the machine or fuel container where there is an open flame, spark, or pilot light, such as on a water heater or on other appliances.
 - Do not fill containers inside a vehicle or on a truck or trailer bed with a plastic liner. Always place containers on the ground and away from your vehicle before filling.
 - Remove the equipment from the truck or trailer and refuel it while it is on the ground. If this is not possible, then refuel from a portable container rather than from a fuel-dispenser nozzle.
 - Do not operate the machine without the entire exhaust system in place and in proper working condition.
 - Keep the fuel-dispenser nozzle in contact with the rim of the fuel tank or container opening at all times until fueling is complete. Do not use a nozzle lock-open device.
 - If you spill fuel on your clothing, change your clothing immediately.
 - Do not overfill the fuel tank. Replace the fuel cap and tighten it securely.
 - Clean grass and debris from the cutting unit, muffler, drives, grass catcher, and engine compartment to help prevent fires. Clean up oil or fuel spills.

Adding Fuel

Recommended Fuel

- For best results, use only clean, fresh (less than 30 days old), unleaded gasoline with an octane rating of 87 or higher ((R+M)/2 rating method).
- **Ethanol:** Gasoline with up to 10% ethanol (gasohol) or 15% MTBE (methyl tertiary butyl ether) by volume is acceptable. Ethanol and MTBE are not the same. Gasoline with 15% ethanol (E15) by volume is not approved for use. **Never use gasoline that contains more than 10% ethanol by volume**, such as E15 (contains 15% ethanol), E20 (contains 20% ethanol), or E85 (contains up to 85% ethanol). Using unapproved gasoline may cause performance problems and/or engine damage which may not be covered under warranty.
- **Do not** use gasoline containing methanol.
- **Do not** store fuel either in the fuel tank or fuel containers over the winter unless you use a fuel stabilizer.
- **Do not** add oil to gasoline.

Using Stabilizer/Conditioner

Use a fuel stabilizer/conditioner in the machine to provide the following benefits:

- Keeps fuel fresh longer when used as directed by the fuel-stabilizer manufacturer
- Cleans the engine while it runs
- Eliminates gum-like varnish buildup in the fuel system, which causes hard starting

Important: Do not use fuel additives containing methanol or ethanol.

Add the correct amount of fuel stabilizer/conditioner to the fuel.

Note: A fuel stabilizer/conditioner is most effective when mixed with fresh fuel. To minimize the chance of varnish deposits in the fuel system, use fuel stabilizer at all times.

Filling the Fuel Tank

1. Park the machine on a level surface.
2. Engage the parking brake.
3. Shut off the engine and remove the key.
4. Clean around the fuel-tank cap.
5. Fill the fuel tank to the bottom of the filler neck (Figure 8).

Note: Do not fill the fuel tank completely full. The empty space in the tank allows the fuel to expand.

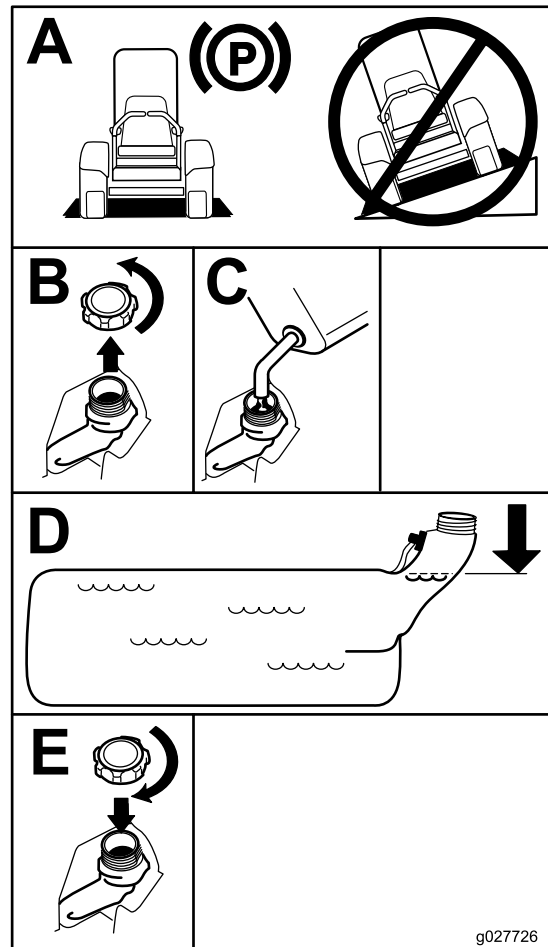

Figure 8

g027726

Performing Daily Maintenance

Before starting the machine each day, perform the Each Use/Daily procedures listed in [Maintenance \(page 39\)](#).

Breaking in a New Machine

New engines take time to develop full power. Mower decks and drive systems have higher friction when new, placing additional load on the engine. Allow 40 to 50 hours of break-in time for new machines to develop full power and best performance.

Using the Rollover-Protection System (ROPS)

⚠ WARNING

To avoid injury or death from rollover, keep the roll bar in the fully raised, locked position and use the seat belt.

Ensure that the seat is secured to the machine.

⚠ WARNING

There is no rollover protection when the roll bar is in the down position.

- Lower the roll bar only when absolutely necessary.
- Do not wear the seat belt when the roll bar is in the down position.
- Drive slowly and carefully.
- Raise the roll bar as soon as clearance permits.
- Check carefully for overhead clearances (i.e., branches, doorways, electrical wires) before driving under any objects and do not contact them.

Lowering the Roll Bar

Important: Lower the roll bar only when absolutely necessary.

1. To lower the roll bar, apply forward pressure to the upper part of the roll bar.
2. Pull both knobs out and rotate them 90 degrees so they are not engaged (Figure 9).
3. Lower the roll bar to the down position (Figure 9).

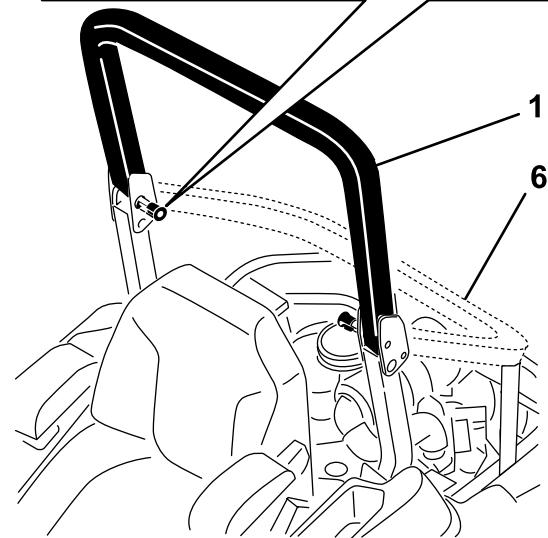
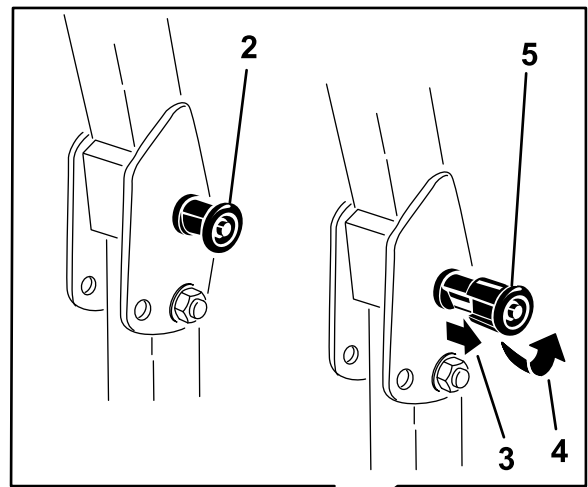

Figure 9

g228804

- | | |
|--------------------------------------|--|
| 1. Roll bar in the upright position | 4. Rotate the ROPS knob 90 degrees. |
| 2. ROPS knob in the latched position | 5. ROPS knob in the unlatched position |
| 3. Pull the ROPS knob out. | 6. Roll bar in the folded position |

Raising the Roll Bar

Important: Always use the seat belt with the roll bar in the raised position.

1. Raise the roll bar to the operating position and rotate the knobs until they move partially into the grooves (Figure 9).
2. Raise the roll bar to the full upright position while pushing on the upper roll bar so that the pins snap into position when the holes align with the pins (Figure 9).
3. Push on the roll bar and ensure that both pins are engaged.

Using the Safety-Interlock System

⚠ WARNING

If the safety-interlock switches are disconnected or damaged, the machine could operate unexpectedly, causing personal injury.

- Do not tamper with the interlock switches.
- Check the operation of the interlock switches daily and replace any damaged switches before operating the machine.

Understanding the Safety-Interlock System

The safety-interlock system is designed to prevent the engine from starting unless the following occurs:

- The parking brake is engaged.
- The blade-control switch (PTO) is disengaged.
- The motion-control levers are in the NEUTRAL-LOCK position.

The safety-interlock system also is designed to shut off the engine when the motion-control levers are moved from the NEUTRAL-LOCK position with the parking brake engaged or if you rise from the seat when the PTO is engaged.

The hour meter has indicators to notify the user when the interlock component is in the correct position. When the component is in the correct position, an indicator displays on the screen.

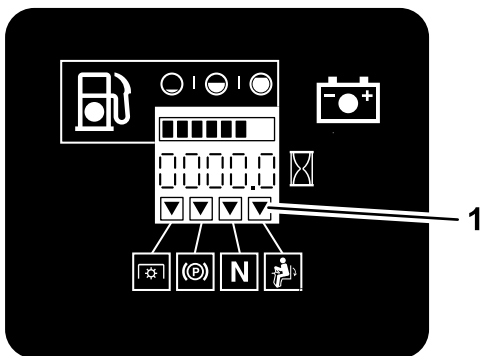

G009181

g009181

Figure 10

Standard hour meter shown

1. Indicators display when the interlock components are in the correct position.

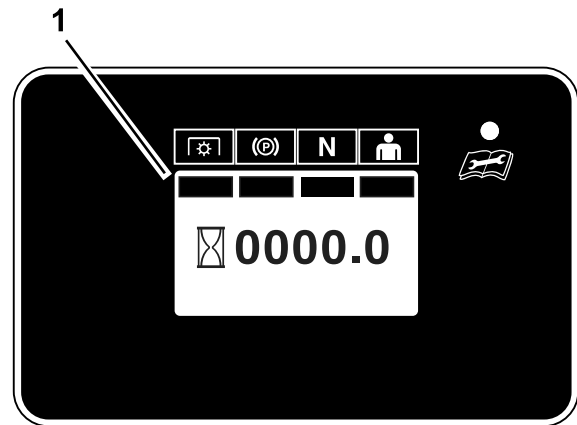

g231781

Figure 11

Smart hour meter shown

1. Indicators display when the interlock components are in the correct position.

Testing the Safety-Interlock System

Service Interval: Before each use or daily

Test the safety-interlock system before you use the machine each time. If the safety system does not operate as described below, have an Authorized Service Dealer repair the safety system immediately.

1. Sit on the seat, engage the parking brake, and move the blade-control switch (PTO) to the ON position. Try starting the engine; the engine should not start.
2. Sit on the seat, engage the parking brake, and move the blade-control switch (PTO) to the OFF position. Move either motion-control lever out of the NEUTRAL-LOCK position. Try starting the engine; the engine should not start. Repeat for the other control lever.
3. Sit on the seat, engage the parking brake, move the blade-control switch (PTO) to the OFF position, and move the motion-control levers to the NEUTRAL-LOCK position. Now start the engine. While the engine is running, disengage the parking brake, engage the blade-control switch (PTO), and rise slightly from the seat; the engine should shut off.
4. Sit on the seat, engage the parking brake, move the blade-control switch (PTO) to the OFF position, and move the motion-control levers to the NEUTRAL-LOCK position. Now start the engine. While the engine is running, center either motion control and move (forward or reverse); the engine should shut off. Repeat for other motion control.

- Sit on the seat, disengage the parking brake, move the blade-control switch (PTO) to the OFF position, and move the motion-control levers to the NEUTRAL-LOCK position. Try starting the engine; the engine should not start.

Positioning the Seat

The seat can move forward and backward. Position the seat where you have the best control of the machine and are most comfortable (Figure 12).

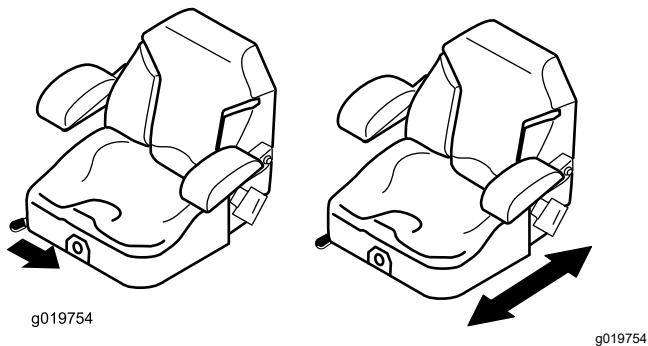

Figure 12

Unlatching the Seat

To unlatch the seat, push the seat latch forward (Figure 13).

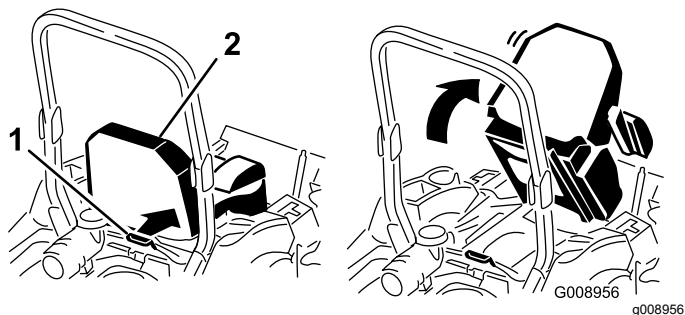

Figure 13

1. Seat latch

2. Seat

Changing the Seat Suspension

The seat is adjustable to provide a smooth and comfortable ride. Position the seat where you are most comfortable.

To adjust it, turn the knob in front either direction to provide the best comfort (Figure 14).

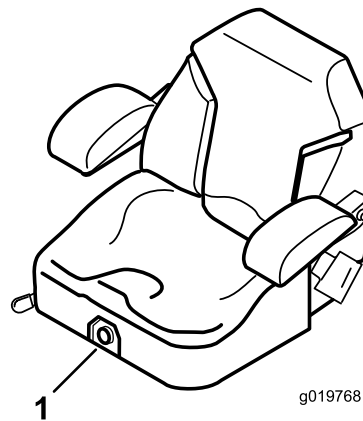

Figure 14

1. Seat-suspension knob

During Operation

During Operation Safety

General Safety

- The owner/operator can prevent and is responsible for accidents that may cause personal injury or property damage.
- Use your full attention while operating the machine. Do not engage in any activity that causes distractions; otherwise, injury or property damage may occur.
- Do not operate the machine while ill, tired, or under the influence of alcohol or drugs.
- Contacting the blade can result in serious personal injury. Shut off the engine, remove the key, and wait for all moving parts to stop before leaving the operating position. When you turn the key to the OFF position, the engine should shut off and the blade should stop. If not, stop using your machine immediately and contact an Authorized Service Dealer.
- Operate the machine only in good visibility and appropriate weather conditions. Do not operate the machine when there is the risk of lightning.
- Keep your hands and feet away from the cutting units. Keep clear of the discharge opening.

- Do not mow with the discharge deflector raised, removed, or altered unless there is a grass-collection system or mulch kit in place and working properly.
- Do not mow in reverse unless it is absolutely necessary. Always look down and behind you before moving the machine in reverse.
- Use extreme care when approaching blind corners, shrubs, trees, or other objects that may block your view.
- Stop the blades whenever you are not mowing.
- If the machine strikes an object or starts to vibrate, immediately shut off the engine, remove the key (if equipped), and wait for all moving parts to stop before examining the machine for damage. Make all necessary repairs before resuming operation.
- Slow down and use caution when making turns and crossing roads and sidewalks with the machine. Always yield the right-of-way.
- Before you leave the operating position, do the following:
 - Park the machine on a level surface.
 - Disengage the power takeoff and lower the attachments.
 - Engage the parking brake.
 - Shut off the engine and remove the key.
 - Wait for all moving parts to stop.
- Operate the engine only in well-ventilated areas. Exhaust gases contain carbon monoxide, which is lethal if inhaled.
- Never leave a running machine unattended.
- Attach towed equipment to the machine only at the hitch point.
- Do not operate the machine unless all guards and safety devices, such as the deflectors and the entire grass catcher, are in place and functioning properly. Replace worn or deteriorated parts when necessary.
- Use only accessories and attachments approved by Toro.
- This machine produces sound levels in excess of 85 dBA at the operator's ear and can cause hearing loss through extended periods of exposure.

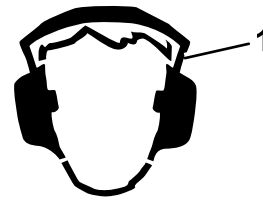

Figure 15

g229846

1. Wear hearing protection.

-
- Clean grass and debris from the cutting unit, drives, muffler, and engine to help prevent fires.
 - Start the engine with your feet well away from the blades.
 - Never raise the mower deck while the blades are moving.
 - Be aware of the mower discharge path and direct the discharge away from others. Avoid discharging material against a wall or obstruction because the material may ricochet back toward you.
 - Stop the blades, slow down the machine, and use caution when crossing surfaces other than grass or when transporting the machine to and from the operating area.
 - Do not change the engine governor speed or overspeed the engine.
 - Children are often attracted to the machine and the mowing activity. Never assume that children will remain where you last saw them.
 - Keep children out of the operating area and under the watchful care of a responsible adult other than the operator.
 - Be alert and shut off the machine if children enter the operating area.
 - Before backing up or turning the machine, look down and all around for small children.
 - Do not carry children on the machine, even when the blades are not moving. Children could fall off and be seriously injured or prevent you from safely operating the machine. Children who have been given rides in the past could appear in the operating area without warning and be run over or backed over by the machine.

Rollover Protection System (ROPS) Safety

- The ROPS is an integral safety device. Do not remove any of the ROPS components from the machine.
- Ensure that the seat belt is attached and that you can release it quickly in an emergency.
- Keep the roll bar in the fully raised and locked position and always wear your seat belt whenever the roll bar is up.

- Check carefully for overhead objects before you drive under them, and do not contact them.
- Replace damaged ROPS components. Do not repair or alter them.
- There is no rollover protection when the roll bar is down.
- Wheels dropping over edges, over steep banks, or into water can cause a rollover, which may result in serious injury or death.
- Do not wear the seat belt when the roll bar is down.
- Lower the roll bar only when absolutely necessary; raise it as soon as clearance permits.
- In the event of a rollover, take the machine to an Authorized Service Dealer to inspect the ROPS.
- Use only Toro approved accessories and attachments for the ROPS.

grass, across slopes, or downhill may cause the machine to lose traction. Loss of traction to the drive wheels may result in sliding and a loss of braking and steering. The machine can slide even if the drive wheels are stopped.

- Remove or mark obstacles such as ditches, holes, ruts, bumps, rocks, or other hidden hazards. Tall grass can hide obstacles. Uneven terrain could overturn the machine.
- Use extra care while operating with accessories or attachments, such as grass-collection systems. These can change the stability of the machine and cause a loss of control. Follow directions for counterweights.
- If possible, keep the deck lowered to the ground while operating on slopes. Raising the deck while operating on slopes can cause the machine to become unstable.

Slope Safety

- Slopes are a major factor related to loss of control and rollover accidents, which can result in severe injury or death. The operator is responsible for safe slope operation. Operating the machine on any slope requires extra caution. Before using the machine on a slope, do the following:
 - Review and understand the slope instructions in the manual and on the machine.
 - Use an angle indicator to determine the approximate slope angle of the area.
 - Never operate on slopes greater than 15°.
 - Evaluate the site conditions of the day to determine if the slope is safe for machine operation. Use common sense and good judgment when performing this evaluation. Changes in the terrain, such as moisture, can quickly affect the operation of the machine on a slope.
- Identify hazards at the base of the slope. Do not operate the machine near drop-offs, ditches, embankments, water, or other hazards. The machine could suddenly roll over if a wheel goes over the edge or the edge collapses. Keep a safe distance (twice the width of the machine) between the machine and any hazard. Use a walk-behind mower and/or a hand trimmer to mow the grass in these areas.
- Avoid starting, stopping, or turning the machine on slopes. Avoid making sudden changes in speed or direction; turn slowly and gradually.
- Do not operate a machine under any conditions where traction, steering, or stability is in question. Be aware that operating the machine on wet

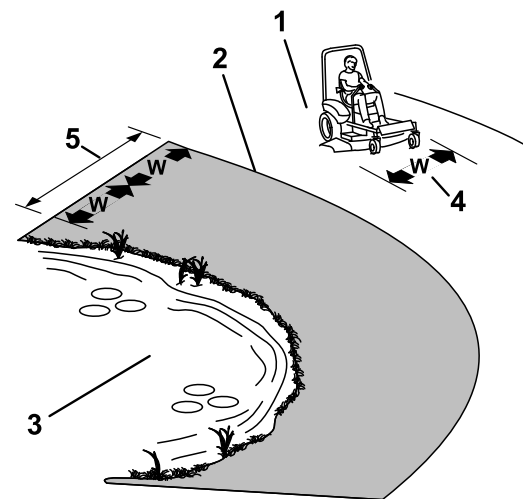

Figure 16

g221745

1. Safe Zone—use the machine here on slopes less than 15° or flat areas.
2. Danger Zone—use a walk-behind mower and/or a hand trimmer on slopes greater than 15° and near drop-offs or water.
3. Water
4. W = Width of the machine
5. Keep a safe distance (twice the width of the machine) between the machine and any hazard.

Operating the Parking Brake

Always engage the parking brake when you stop the machine or leave it unattended.

Engaging the Parking Brake

Park the machine on a level surface.

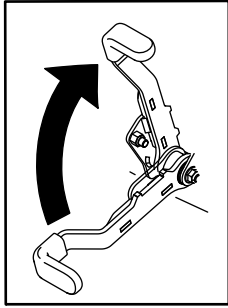

g027334

Figure 17

g027334

Operating the Mower Blade-Control Switch (PTO)

The blade-control switch (PTO) starts and stops the mower blades and any powered attachments.

Engaging the Blade-Control Switch (PTO)

Note: Engaging the blade-control switch (PTO) with the throttle position at half or less causes excessive wear to the drive belts.

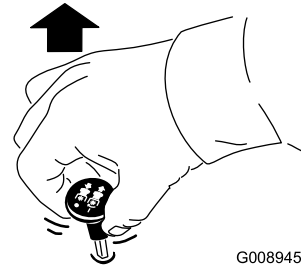

G008945

Figure 19

g008945

Disengaging the Parking Brake

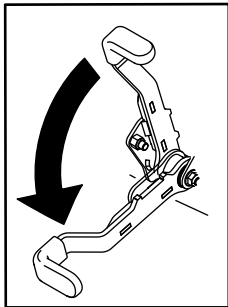

g027335

Figure 18

g027335

Disengaging the Blade-Control Switch (PTO)

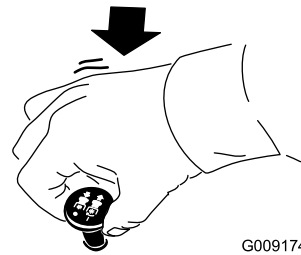

G009174

Figure 20

g009174

Operating the Throttle

You can move the throttle control between FAST and SLOW positions (Figure 21).

Always use the FAST position when engaging the PTO.

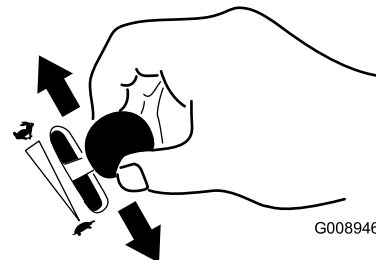

G008946

Figure 21

g008946

Starting the Engine

Important: Do not engage starter for more than 5 seconds at a time. If the engine fails to start, wait 15 seconds between attempts. Failure to follow these instructions can burn out the starter motor.

Note: You may need multiple attempts to start the engine the first time after adding fuel to an empty fuel system.

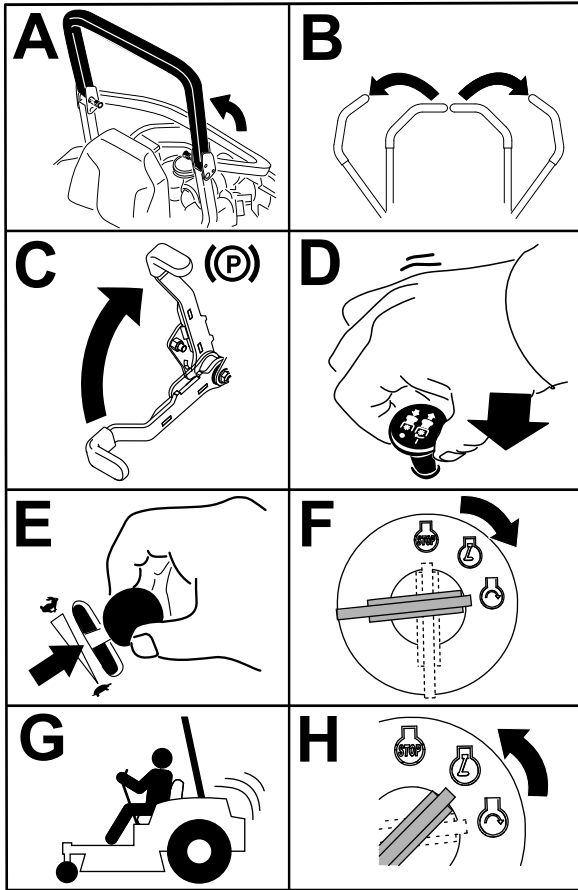

g032328
g032328

Figure 22

Shutting Off the Engine

⚠ CAUTION

Children or bystanders may be injured if they move or attempt to operate the machine while it is unattended.

Always remove the key and engage the parking brake when leaving the machine unattended.

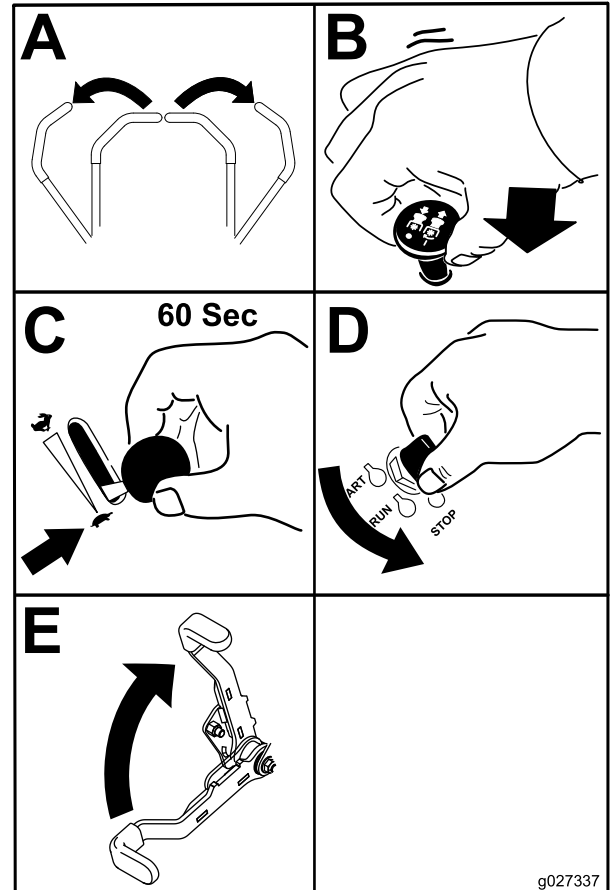

g027337

Figure 23

Important: Make sure that the fuel-shutoff valve is closed before transporting or storing the machine, as fuel leakage may occur. Engage the parking brake before transporting. Make sure that you remove the key as the fuel pump may run and cause the battery to lose charge.

Using the Motion-Control Levers

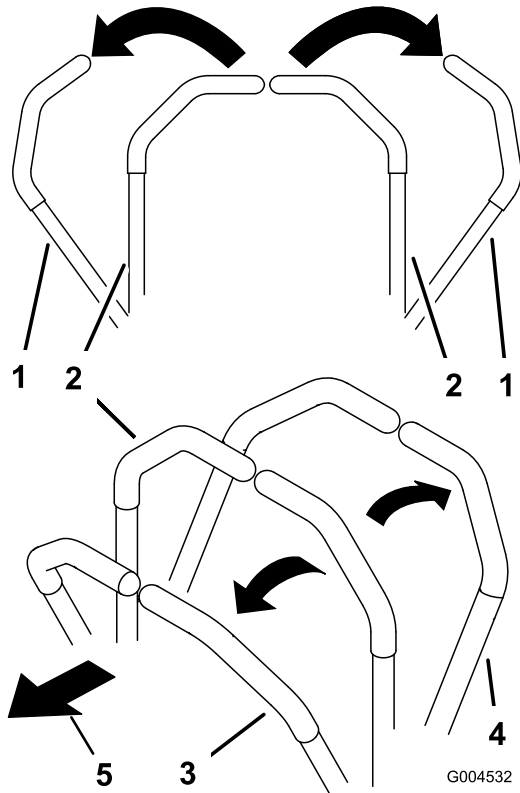

Figure 24

- | | |
|---|---------------------|
| 1. Motion-control lever—NEUTRAL-LOCK position | 4. Backward |
| 2. Center, unlocked position | 5. Front of machine |
| 3. Forward | |

Driving the Machine

The drive wheels turn independently, powered by hydraulic motors on each axle. You can turn 1 side in reverse while you turn the other forward, causing the machine to spin rather than turn. This greatly improves the machine maneuverability but may require some time for you to adapt to how it moves.

The throttle control regulates the engine speed as measured in rpm (revolutions per minute). Place the throttle control in the FAST position for best performance. Always operate in the full throttle position when mowing.

⚠ WARNING

The machine can spin very rapidly. You may lose control of the machine and cause personal injury or damage to the machine.

- Use caution when making turns.
- Slow the machine down before making sharp turns.

Driving Forward

Note: The engine shuts off when you move the traction-control with the parking brake engaged.

To stop the machine, pull the motion-control levers to the NEUTRAL position.

1. Disengage the parking brake; refer to [Disengaging the Parking Brake \(page 27\)](#).
2. Move the levers to the center, unlocked position.
3. To go forward, slowly push the motion-control levers forward (Figure 25).

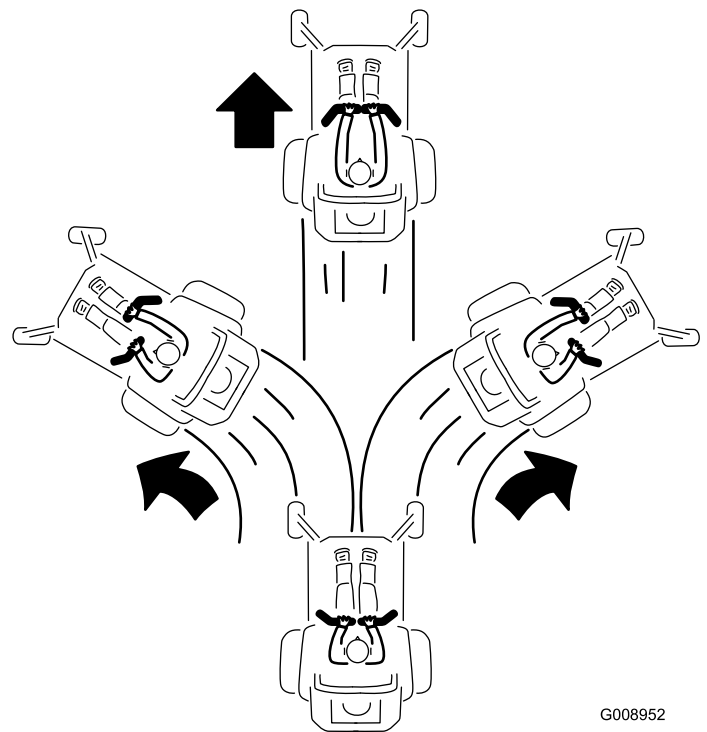
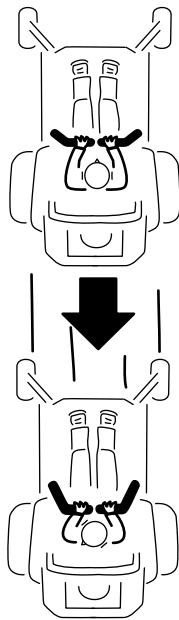

Figure 25

Driving Backward

1. Move the levers to the center, unlocked position.
2. To go backward, slowly pull the motion-control levers rearward (Figure 26).



G008953

g008953

Figure 26

Using the Side Discharge Machines with Side Discharge Only

The mower has a hinged grass deflector that disperses clippings to the side and down toward the turf.

⚠ DANGER

Without a grass deflector, discharge cover, or a complete grass-catcher assembly mounted in place, you and others are exposed to blade contact and thrown debris. Contact with rotating mower blade(s) and thrown debris will cause injury or death.

- **Never remove the grass deflector from the mower deck because the grass deflector routes material down toward the turf. If the grass deflector is ever damaged, replace it immediately.**
- **Never put your hands or feet under the mower deck.**
- **Never try to clear the discharge area or mower blades unless you move the blade-control switch (PTO) to the OFF position, rotate the key switch to the OFF position, and remove the key from the key switch.**
- **Make sure that the grass deflector is in the down position.**

Adjusting the Height of Cut

Using the Transport Lock

The transport lock has 2 positions, and is used with the deck-lift pedal. There is a LOCK position and an UNLOCK position for the transport position of the mower deck (Figure 27).

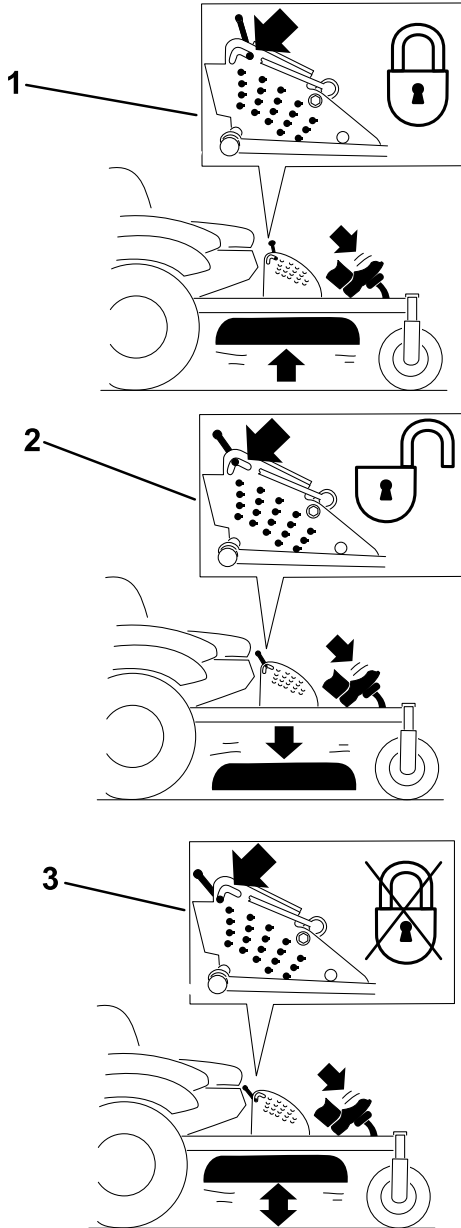

Figure 27

Transport-Lock Positions

1. Transport lock knob
2. LOCK position—The mower deck locks into the transport position.
3. UNLOCK position—The mower deck does not lock into the transport position.

Adjusting the Height-of-Cut Pin

The height-of-cut is adjusted from 25 to 140 mm (1 to 5-1/2 inches) in 6 mm (1/4 inch) increments by relocating the clevis pin into different hole locations.

1. Move the transport lock to the lock position.
2. Push on the deck-lift pedal with your foot, and raise the mower deck to the transport position (also the 140 mm (5-1/2 inch) cutting height position) as shown in Figure 28.
3. To adjust, rotate the pin 90 degrees and remove the pin from the height-of-cut bracket (Figure 28).
4. Select a hole in the height-of-cut bracket corresponding to the height-of-cut desired, and insert the pin (Figure 28).
5. Push on the deck lift, pull back on the transport lock, and slowly lower the mower deck.

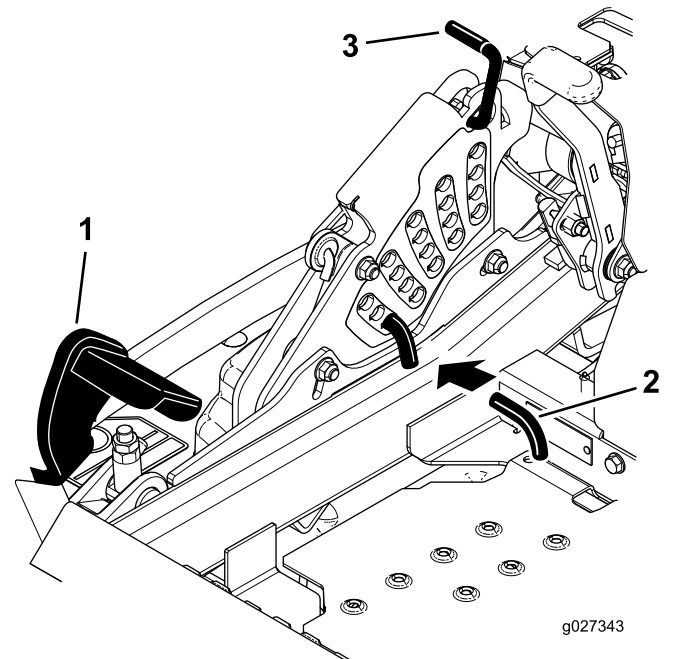

Figure 28

1. Deck-lift pedal
2. Cut-of-height pin
3. Transport lock

Adjusting the Anti-Scalp Rollers

Machines with Side Discharge

Whenever you change the height-of-cut, adjust the height of the anti-scalp rollers.

1. Park the machine on a level surface, disengage the blade-control switch, and engage the parking brake.
2. Shut off the engine, remove the key, and wait for all moving parts to stop before leaving the operating position.
3. Adjust the anti-scalp rollers as shown in [Figure 29](#), [Figure 30](#), and [Figure 31](#).

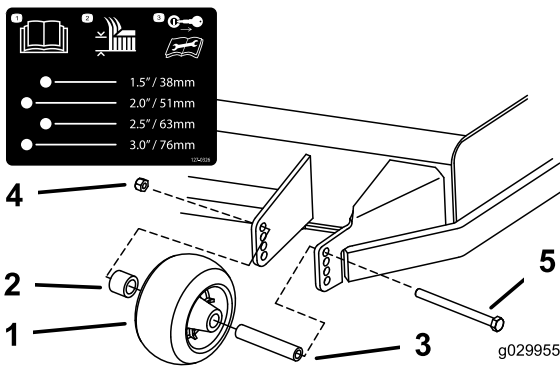

Figure 29

- | | |
|----------------------|---------------|
| 1. Anti-scalp roller | 4. Flange nut |
| 2. Spacer | 5. Bolt |
| 3. Bushing | |

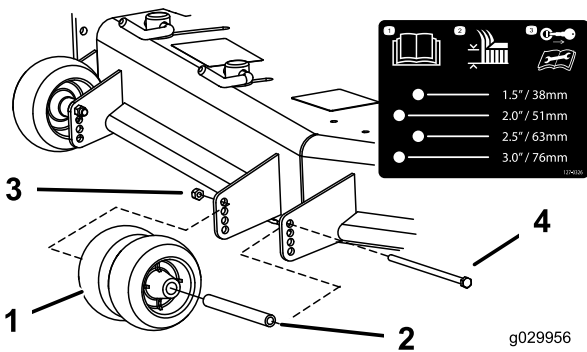

Figure 30

- | | |
|----------------------|---------------|
| 1. Anti-scalp roller | 3. Flange nut |
| 2. Bushing | 4. Bolt |

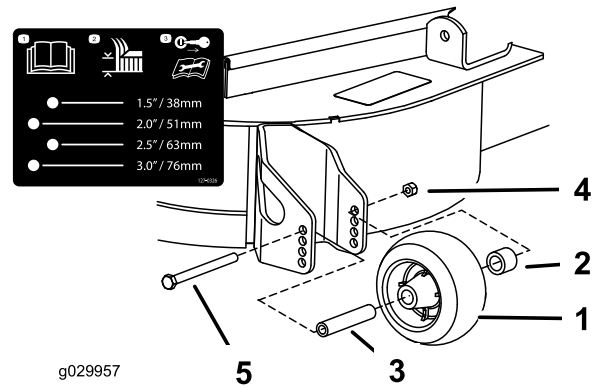

Figure 31

- | | |
|----------------------|---------------|
| 1. Anti-scalp roller | 4. Flange nut |
| 2. Spacer | 5. Bolt |
| 3. Bushing | |

Machines with Rear Discharge

Whenever you change the height of cut, it is recommended to adjust the height of the anti-scalp rollers.

1. Park the machine on a level surface, disengage the blade-control switch, and engage the parking brake.
2. Shut off the engine, remove the key, and wait for all moving parts to stop before leaving the operating position.
3. Adjust the anti-scalp rollers as shown in [Figure 32](#) and [Figure 33](#).

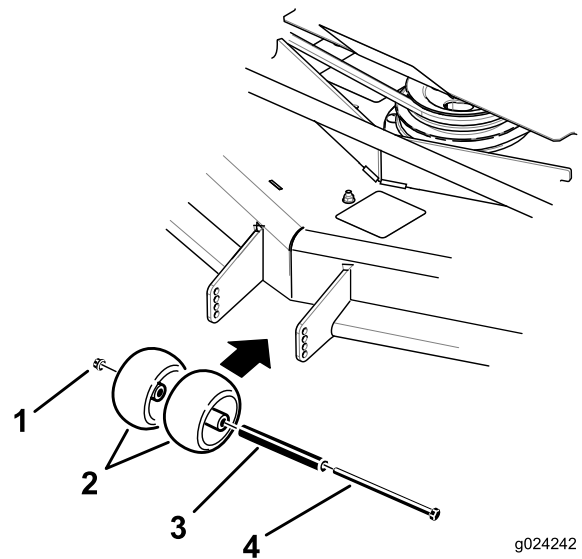

Figure 32

- | | |
|----------------------|------------|
| 1. Flange nut | 3. Bushing |
| 2. Anti-scalp roller | 4. Bolt |

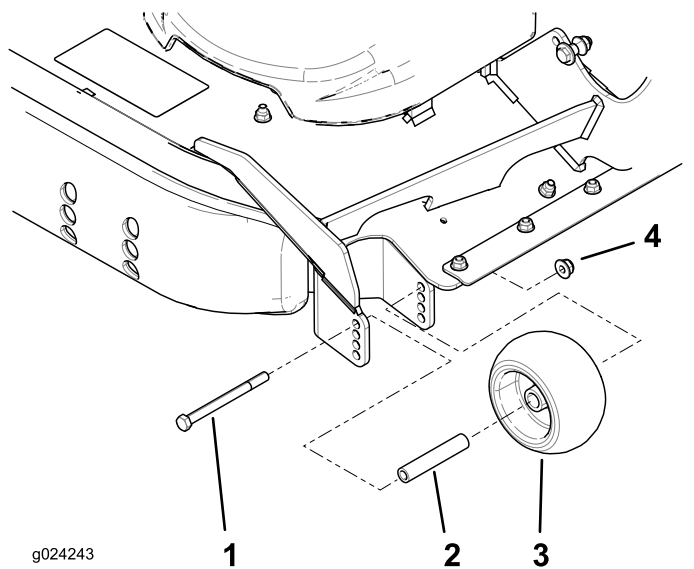

Figure 33

- | | |
|------------|----------------------|
| 1. Bolt | 3. Anti-scalp roller |
| 2. Bushing | 4. Flange nut |

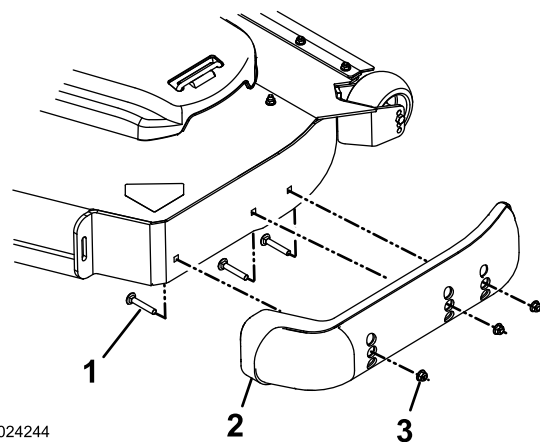

Figure 34

- | | |
|------------------|--------|
| 1. Carriage bolt | 3. Nut |
| 2. Skid | |

Adjusting the Skid(s) For Machines with Rear Discharge

Mount the skids in the lower position when operating in height of cuts higher than 64 mm (2-1/2 inches) and in the higher position when operating in height of cuts lower than 64 mm (2-1/2 inches).

Note: When the skids become worn, switch the skid to the opposite sides of the mower, flipping them over. This allows you to use the skids longer before replacing them.

1. Park the machine on a level surface, disengage the blade-control switch, and engage the parking brake.
2. Shut off the engine, remove the key, and wait for all moving parts to stop before leaving the operating position.
3. Remove the carriage bolts and nuts from each skid (Figure 34).

4. Move each skid to the desired position and secure them with the carriage bolts and nuts.

Note: Only use the top or center sets of holes to adjust the skids. The bottom holes are used when switching sides on the mower deck, at which time they become the top holes on the other side of the mower.

5. To prevent damaging the skid, torque the carriage bolts and nuts for each skid to 12.4 to 14.7 N·m (110 to 130 in-lb).

Adjusting the Flow Baffle Knob

For Machines with Side Discharge

This procedure applies only to machines with the flow baffle knob. Certain models have nuts and bolts instead of the flow baffle knob that you can adjust the same way.

You can adjust the mower discharge flow for different types of mowing conditions. Position the knob and baffle to give the best quality of cut.

1. Park the machine on a level surface, disengage the blade-control switch, and engage the parking brake.
2. Shut off the engine, remove the key, and wait for all moving parts to stop before leaving the operating position.
3. Loosen the knob.
4. Slide the knob to the desired position.
5. Tighten the knob.

Positioning the Flow Baffle For Machines with Side Discharge

The following figures are recommendations only. Adjustments vary by grass type, moisture content, and the height of the grass.

Note: If the engine power draws down and the mower ground speed is the same, open the baffle.

Position A

This is the fully-rear position. The suggested use for this position is as follows:

- Short, light grass mowing conditions
- Dry conditions
- Smaller grass clippings
- Propels grass clippings farther away from the mower

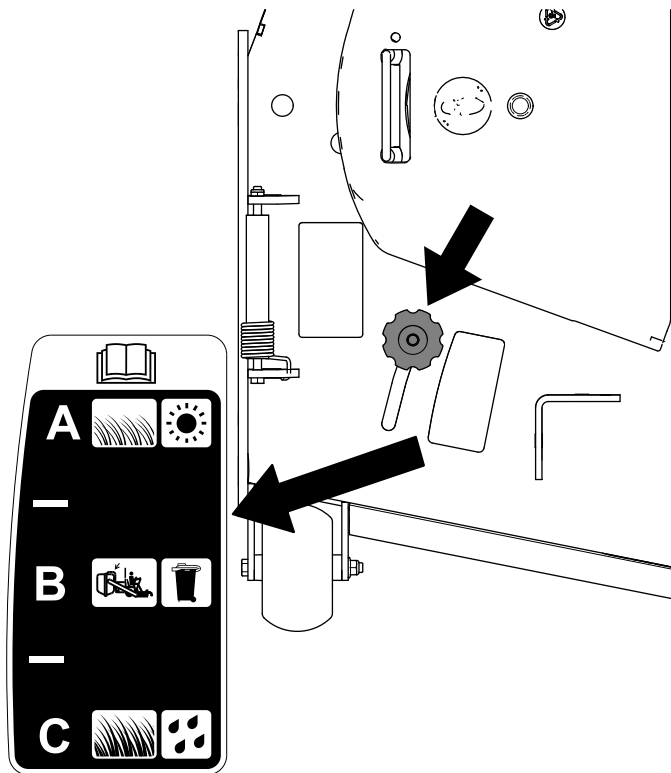

Figure 35

g295810

Position B

Use this position when bagging. Always align it with the blower opening.

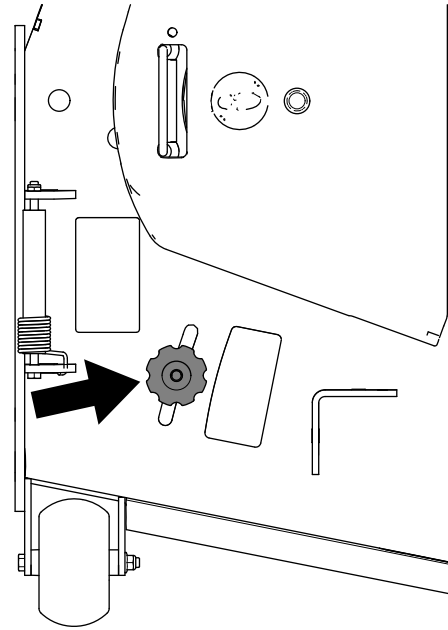

Figure 36

g295811

Position C

This is the fully-forward position. The suggested use for this position is as follows:

- Tall, dense grass mowing conditions
- Wet conditions
- Lowers the engine-power consumption
- Allows increased ground speed in heavy conditions

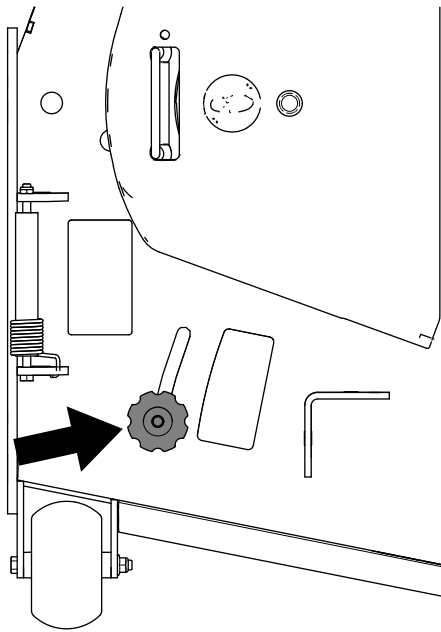

Figure 37

g295812

Mowing at Correct Intervals

Grass grows at different rates at different times of the year. To maintain the same cutting height, mow more often in early spring. As the grass growth rate slows in mid summer, mow less frequently. If you cannot mow for an extended period, first mow at a high cutting height, then mow again 2 days later at a lower height setting.

Using a Slower Cutting Speed

To improve cut quality, use a slower ground speed in certain conditions.

Avoiding Cutting Too Low

When mowing uneven turf, raise the cutting height to avoid scalping the turf.

Operating Tips

Using the Fast Throttle Setting

For best mowing and maximum air circulation, operate the engine at the FAST position. Air is required to thoroughly cut grass clippings, so do not set the height-of-cut so low as to totally surround the mower deck in uncut grass. Always try to have 1 side of the mower deck free from uncut grass, which allows air to be drawn into the mower deck.

Cutting a Lawn for the First Time

Cut grass slightly longer than normal to ensure that the cutting height of the mower deck does not scalp any uneven ground. However, the cutting height used in the past is generally the best one to use. When cutting grass longer than 15 cm (6 inches) tall, you may want to cut the lawn twice to ensure an acceptable quality of cut.

Cutting a Third of the Grass Blade

It is best to cut only about a third of the grass blade. Cutting more than that is not recommended unless grass is sparse, or it is late fall when grass grows more slowly.

Alternating the Mowing Direction

Alternate the mowing direction to keep the grass standing straight. This also helps disperse clippings, which enhances decomposition and fertilization.

Stopping the Machine

If you must stop the forward motion of the machine while mowing, a clump of grass clippings may drop onto your lawn. To avoid this, move onto a previously cut area with the blades engaged or you can disengage the mower deck while moving forward.

Keeping the Underside of the Mower Deck Clean

Clean clippings and dirt from the underside of the mower deck after each use. If grass and dirt build up inside the mower deck, cutting quality will eventually become unsatisfactory.

Maintaining the Blade(s)

Maintain a sharp blade throughout the cutting season because a sharp blade cuts cleanly without tearing or shredding the grass blades. Tearing and shredding turns grass brown at the edges, which slows growth and increases the chance of disease. Check the mower blades after each use for sharpness, and for any wear or damage. File down any nicks and sharpen the blades as necessary. If a blade is damaged or worn, replace it immediately with a genuine Toro replacement blade.

After Operation

After Operation Safety

General Safety

- Shut off the engine, remove the key, and wait for all moving parts to stop before leaving the operator's position. Allow the machine to cool before servicing, adjusting, fueling, cleaning, or storing it.
- Clean grass and debris from the cutting unit, muffler, drives, grass catcher, and engine compartment to help prevent fires. Clean up oil or fuel spills.
- Shut off the fuel and remove the key before storing or transporting the machine.

Using the Fuel-Shutoff Valve

The fuel-shutoff valve is located under the seat. Move the seat forward to access it.

Close the fuel-shutoff valve for transport, maintenance, and storage.

Ensure that the fuel-shutoff valve is open when starting the engine.

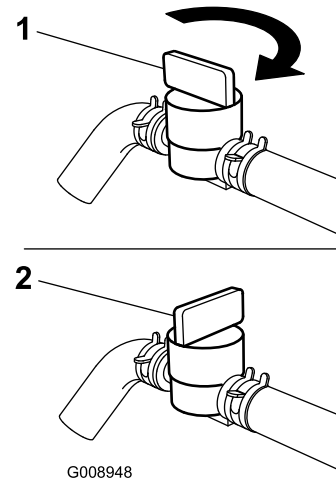

Figure 38

1. ON position

2. OFF position

Using the Drive-Wheel-Release Valves

⚠ WARNING

Hands may become entangled in the rotating drive components below the engine deck, which could result in serious injury.

Shut off the engine, remove the key, and allow all moving parts to stop before accessing the drive-wheel-release valves.

⚠ WARNING

The engine and hydraulic-drive units can become very hot. Touching a hot engine or hydraulic-drive units can cause severe burns.

Allow the engine and hydraulic-drive units to cool completely before accessing the drive-wheel-release valves.

The drive-wheel-release valves are located in the back of each hydraulic-drive unit, under the seat.

Note: Make sure that the release valves are in the fully horizontal position when operating the machine; otherwise, severe damage to the hydraulic system can occur.

1. Park the machine on a level surface, disengage the blade-control switch, and engage the parking brake.
2. Shut off the engine, remove the key, and wait for all moving parts to stop before leaving the operating position.
3. Rotate the release-valve levers vertically to push the machine (Figure 39).

Note: This allows hydraulic fluid to bypass the pump, enabling the wheels to turn.

4. Disengage the parking brake before pushing the machine.

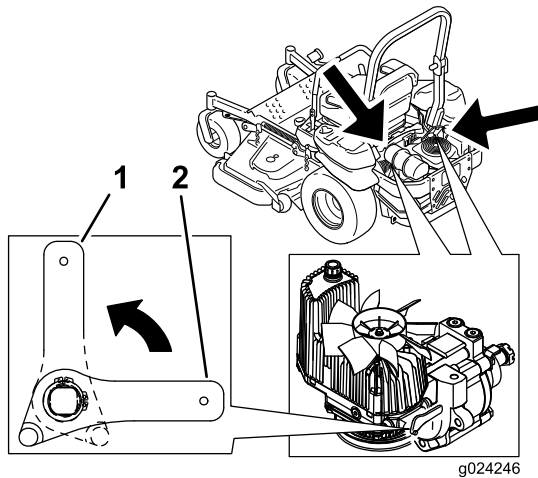

Figure 39

1. Vertical to push the machine
2. Horizontal to run the machine

5. Rotate the release valve levers horizontally to run the machine (Figure 39).

Transporting the Machine

Use a heavy-duty trailer or truck to transport the machine. Use a full-width ramp. Ensure that the trailer or truck has all the necessary brakes, lighting, and marking as required by law. Please carefully read all the safety instructions. Knowing this information could help you or bystanders avoid injury. Refer to your local ordinances for trailer and tie-down requirements.

⚠ WARNING

Driving on the street or roadway without turn signals, lights, reflective markings, or a slow-moving-vehicle emblem is dangerous and can lead to accidents, causing personal injury.

Do not drive the machine on a public street or roadway.

Selecting a Trailer

⚠ WARNING

Loading a machine onto a trailer or truck increases the possibility of tip-over and could cause serious injury or death (Figure 40).

- Use only a full-width ramp; do not use individual ramps for each side of the machine.
- Do not exceed a 15-degree angle between the ramp and the ground or between the ramp and the trailer or truck.
- Ensure that the length of the ramp is at least 4 times as long as the height of the trailer or truck bed to the ground. This ensures that the ramp angle does not exceed 15 degrees on flat ground.

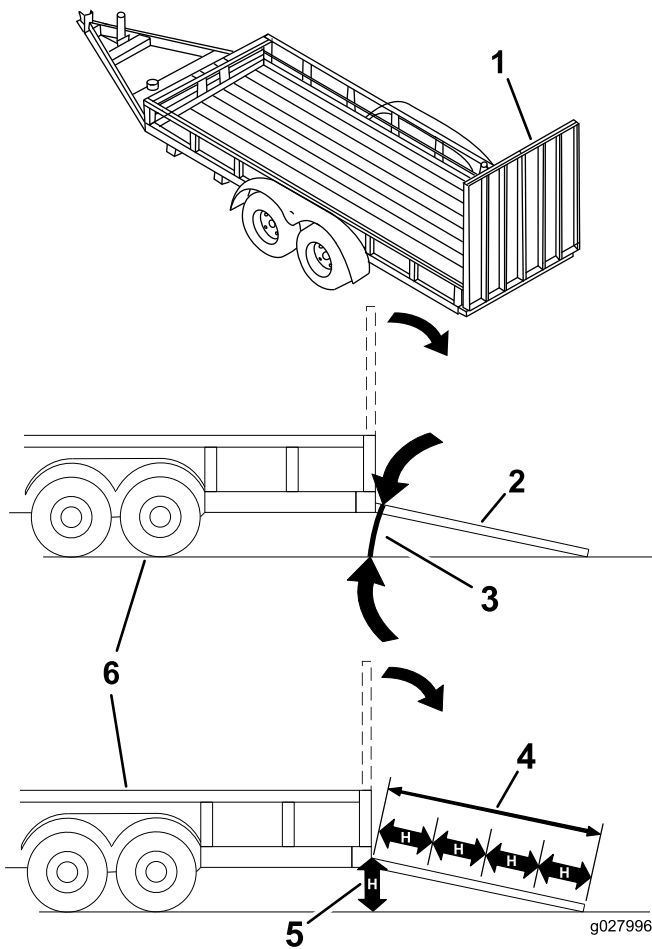

Figure 40

1. Full-width ramp in stowed position
2. Side view of full-width ramp in loading position
3. Not greater than 15 degrees
4. Ramp is at least 4 times as long as the height of the trailer or truck bed to the ground
5. H=height of the trailer or truck bed to the ground
6. Trailer

Loading the Machine

⚠ WARNING

Loading a machine onto a trailer or truck increases the possibility of tip-over and could cause serious injury or death.

- Use extreme caution when operating a machine on a ramp.
- Back the machine up the ramp and drive it forward down the ramp.
- Avoid sudden acceleration or deceleration while driving the machine on a ramp as this could cause a loss of control or a tip-over situation.

1. If using a trailer, connect it to the towing vehicle and connect the safety chains.
2. If applicable, connect the trailer brakes and lights.
3. Lower the ramp, ensuring that the angle between the ramp and the ground does not exceed 15 degrees (Figure 40).
4. Back the machine up the ramp (Figure 41).

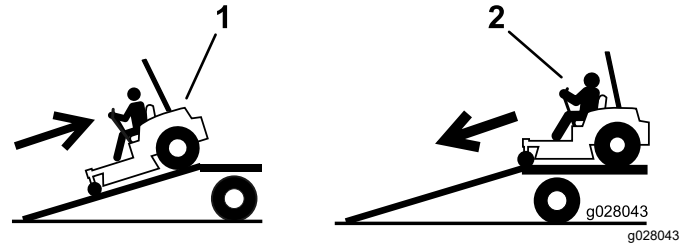

Figure 41

1. Back the machine up the ramp.
2. Drive the machine forward down the ramp.

5. Shut off the engine, remove the key, and engage the parking brake.
6. Tie down the machine near the front caster wheels and the rear bumper with straps, chains, cable, or ropes (Figure 42). Refer to local regulations for tie-down requirements.

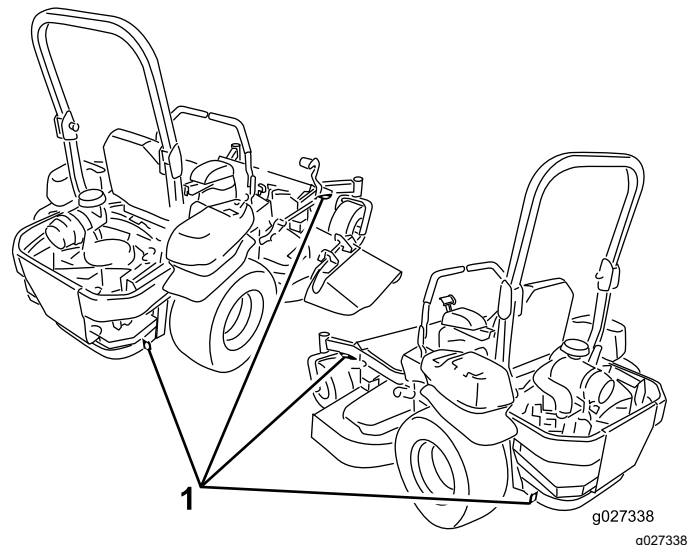

Figure 42

1. Tie-down loops

Unloading the Machine

1. Lower the ramp, ensuring that the angle between the ramp and the ground does not exceed 15 degrees (Figure 40).
2. Drive the machine forward down the ramp (Figure 41).

Maintenance

Maintenance Safety

- If you leave the key in the switch, someone could accidentally start the engine and seriously injure you or other bystanders. Remove the key from the switch before you perform any maintenance.
- Before you leave the operator’s position, do the following:
 - Park the machine on a level surface.
 - Disengage the drives.
 - Engage the parking brake.
 - Shut off the engine and remove the key.
 - Allow machine components to cool before performing maintenance.
- Do not allow untrained personnel to service the machine.
- Keep your hands and feet away from moving parts or hot surfaces. If possible, do not make adjustments with the engine running.
- Carefully release pressure from components with stored energy.
- Check the parking brake operation frequently. Adjust and service it as required.
- Never tamper with safety devices. Check their proper operation regularly.
- Clean grass and debris from the cutting unit, muffler, drives, grass catcher, and engine compartment to prevent fires.
- Clean up oil or fuel spills and remove fuel-soaked debris.
- Do not rely on hydraulic or mechanical jacks to support the machine; support the machine with jack stands whenever you raise the machine.
- Keep all parts in good working condition and all hardware tightened, especially the blade-attachment hardware. Replace all worn or damaged decals.
- Disconnect the battery before repairing the machine. Disconnect the negative terminal first and the positive last. Connect the positive terminal first and the negative last.
- To ensure optimum performance, use only genuine Toro replacement parts and accessories. Replacement parts and accessories made by other manufacturers could be dangerous, and such use could void the product warranty.

Recommended Maintenance Schedule(s)

Maintenance Service Interval	Maintenance Procedure
After the first 100 hours	<ul style="list-style-type: none"> • Check the wheel lug-nut torque. • Check the wheel-hub slotted-nut torque. • Adjust the parking brake.
After the first 250 hours	<ul style="list-style-type: none"> • Change the hydraulic filters and hydraulic fluid.
Before each use or daily	<ul style="list-style-type: none"> • Check the safety-interlock system. • For Kawasaki engines—check the engine-oil level. • For Kohler engines—check the air cleaner for dirty, loose or damaged parts. • For Kohler engines—check the engine-oil level. • Check the seat belt. • Check the roll bar knobs. • Clean the engine screen and the oil cooler. • Check and clean the hydraulic-unit shrouds. • Inspect the blades.
After each use	<ul style="list-style-type: none"> • Clean the mower deck.
Every 50 hours	<ul style="list-style-type: none"> • Check the spark arrester (if equipped). • Check the tire pressure. For machines with pneumatic tires only. • Inspect the belts for cracks and wear. • Check the hydraulic-fluid level.
Every 100 hours	<ul style="list-style-type: none"> • Lubricate the mower deck-lift pivots. • For Kawasaki engines—change the engine oil (more often in dirty or dusty conditions). • For Kawasaki engines—replace or clean and gap the spark plug. • For Kohler engines—change the engine oil (more often in dirty or dusty conditions). • Check and clean engine-cooling fins and shrouds.

Maintenance Service Interval	Maintenance Procedure
Every 200 hours	<ul style="list-style-type: none"> • For Kawasaki engines—change the engine-oil filter (more often in dirty or dusty conditions). • For Kohler engines—change the engine-oil filter (more often in dirty or dusty conditions). • For Kohler engines—change the engine-oil filter (more often in dirty or dusty conditions). • For Kohler engines—check the spark plug(s). • Replace the fuel filter (more often in dirty or dusty conditions).
Every 250 hours	<ul style="list-style-type: none"> • For Kawasaki engines—replace the primary air filter (more often in dirty or dusty conditions). • For Kawasaki engines—check the safety air filter (more often in dirty or dusty conditions). • For Kohler engines—service or replace the air-cleaner foam element (more often under dusty, dirty conditions). • After the initial change—change the hydraulic-system filters and fluid when using Mobil 1 15W50 fluid. (Change it more often under dirty or dusty conditions)
Every 300 hours	<ul style="list-style-type: none"> • For Kawasaki engines—Check and adjust the valve clearance. See an Authorized Service Dealer.
Every 400 hours	<ul style="list-style-type: none"> • Grease the caster pivots (more often in dirty or dusty conditions).
Every 500 hours	<ul style="list-style-type: none"> • For Kawasaki engines—replace the safety air filter (more often in dirty or dusty conditions). • For Kohler engines—replace the air-cleaner paper element (more often under dusty, dirty conditions). • For Kohler engines—replace the spark plug(s). • Check the wheel lug-nut torque. • Check the wheel-hub slotted-nut torque. • Adjust the caster-pivot bearing. • Adjust the parking brake. • After the initial change—change the hydraulic-system filters and fluid when using Toro® HYPR-OIL™ 500 fluid. (Change it more often under dirty or dusty conditions)
Monthly	<ul style="list-style-type: none"> • Check the battery charge.
Yearly	<ul style="list-style-type: none"> • Grease the pump-belt-idler arm. • Repack the caster-wheel bearings (more often in dirty or dusty conditions). • Greasing the caster-wheel hubs.
Yearly or before storage	<ul style="list-style-type: none"> • Paint chipped surfaces. • Check all maintenance procedures listed above before storage.

Important: Refer to your engine owner's manual for additional maintenance procedures.

▲ CAUTION

If you leave the key in the switch, someone could accidentally start the engine and seriously injure you or other bystanders.

Shut off the engine and remove the key from the switch before you perform any maintenance.

Lubrication

Greasing the Machine

Grease the machine more often in dirty or dusty conditions.

Grease Type: No. 2 lithium or molybdenum grease

1. Park the machine on a level surface, disengage the blade-control switch, and engage the parking brake.
2. Shut off the engine, remove the key, and wait for all moving parts to stop before leaving the operating position.

3. Clean the grease fittings with a rag.

Note: Scrape any paint off the front of the fitting(s).

4. Connect a grease gun to the fitting.
5. Pump grease into the fittings until grease begins to ooze out of the bearings.
6. Wipe up any excess grease.

Lubricating the Mower Deck-Lift Pivots

Service Interval: Every 100 hours

Use light oil or spray lubricant to lubricate the deck-lift pivots.

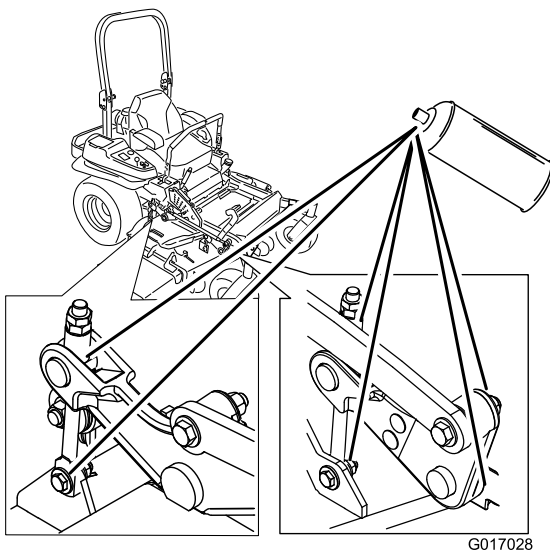

Figure 43

Machine with Side Discharge Shown

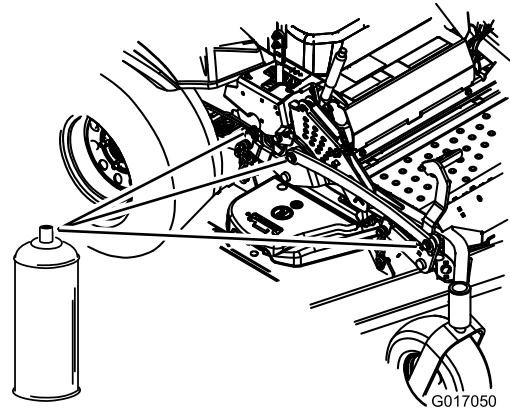

Figure 44

g017050

Greasing the Mower Deck

Service Interval: Yearly—Grease the pump-belt-idler arm.

1. Park the machine on a level surface, disengage the blade-control switch, and engage the parking brake.
2. Shut off the engine, remove the key, and wait for all moving parts to stop before leaving the operating position.
3. Grease the mower deck idler-pulley pivot until grease comes out the bottom ([Figure 45](#) or [Figure 46](#)).

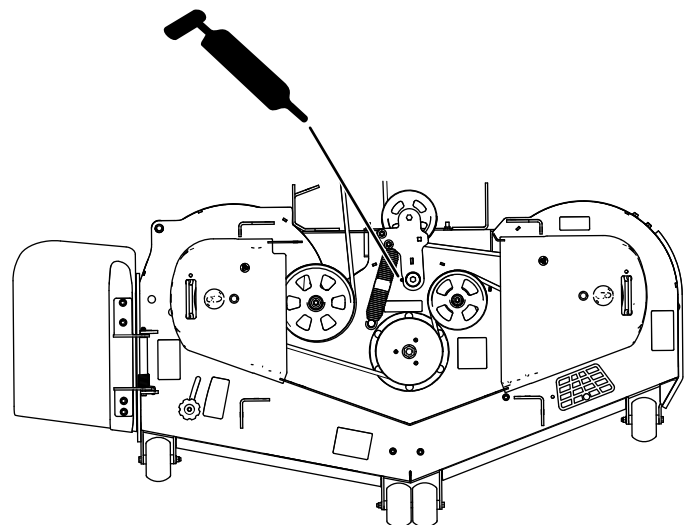

Figure 45

Machine with Side Discharge Shown

g295792

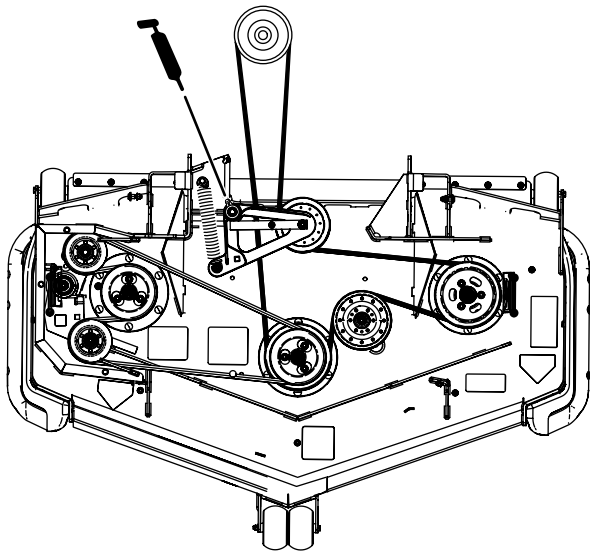

Figure 46

Machine with Rear Discharge Shown

g192516

4. Grease the drive-belt idler arms (Figure 47).

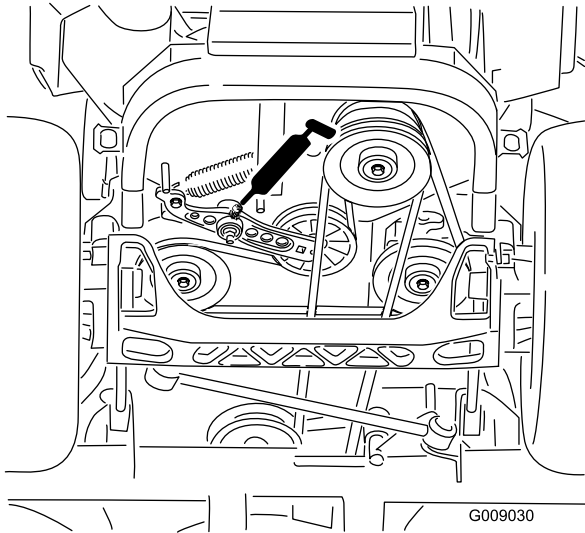

Figure 47

G009030

g009030

5. Grease the deck-belt idler arms (rear discharge machines only) as shown in Figure 48.

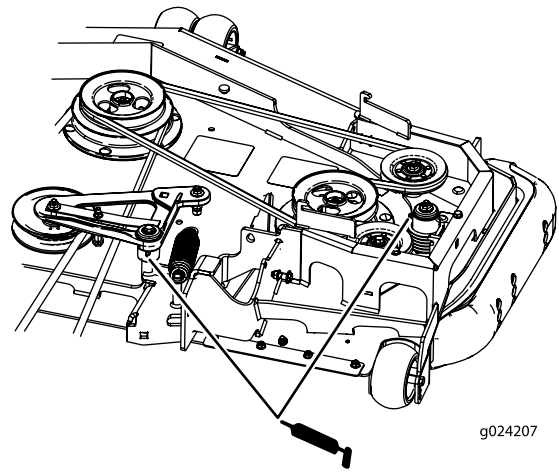

Figure 48

Machines with Rear Discharge Only

g024207

g024207

6. Remove the dust cap and adjust the caster pivots.

Note: Keep the dust cap off until greasing is done.

7. Remove the hex plug.
8. Thread a grease fitting into the hole.
9. Pump grease into the fitting until it oozes out around the top bearing.
10. Remove the grease fitting in the hole.
11. Install the hex plug and dust cap (Figure 49).

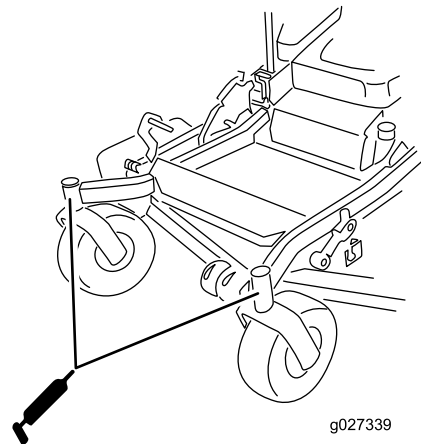

Figure 49

g027339

g027339

12. Grease the caster-wheel bearings (Figure 49).

Greasing the Caster Pivots

Service Interval: Every 400 hours/Yearly (whichever comes first) (more often in dirty or dusty conditions).

Yearly—Repack the caster-wheel bearings (more often in dirty or dusty conditions).

1. Park the machine on a level surface, disengage the blade-control switch, and engage the parking brake.
2. Shut off the engine, remove the key, and wait for all moving parts to stop before leaving the operating position.
3. Remove the dust cap and adjust the caster pivots and keep the dust cap off until greasing is done; refer to [Greasing the Mower Deck \(page 41\)](#).
4. Remove the hex plug.
5. Thread a grease fitting into the hole.
6. Pump grease into the fitting until it oozes out around the top bearing.
7. Remove the grease fitting from the hole. Install the hex plug and cap.

Greasing the Caster-Wheel Hubs

Service Interval: Yearly

1. Park the machine on a level surface, disengage the blade-control switch, and engage the parking brake.
2. Shut off the engine, remove the key, and wait for all moving parts to stop before leaving the operating position.
3. Raise the mower for access.
4. Remove the caster wheel from the caster forks.
5. Remove the seal guards from the wheel hub.

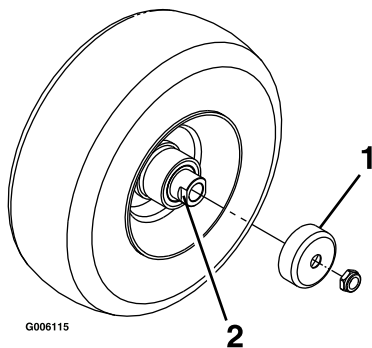

Figure 50

1. Seal guard
2. Spacer nut with wrench flats

6. Remove a spacer nut from the axle assembly in the caster wheel.

Note: Thread-locking compound has been applied to lock the spacer nuts to the axle.

7. Remove the axle (with the other spacer nut still assembled to it) from the wheel assembly.
8. Pry out seals and inspect bearings for wear or damage and replace if necessary.
9. Pack the bearings with a general-purpose grease.
10. Insert 1 bearing and 1 new seal into the wheel.
11. If the axle assembly is missing both spacer nuts, apply a thread-locking compound to 1 spacer nut and thread it onto the axle with the wrench flats facing outward.

Note: Do not thread the spacer nut all of the way onto the end of the axle. Leave approximately 3 mm (1/8 inch) from the outer surface of the spacer nut to the end of the axle inside the nut.

12. Insert the assembled nut and axle into the wheel on the side with the new seal and bearing.
13. With the open end of the wheel facing up, fill the area inside the wheel around the axle full of general-purpose grease.
14. Insert the second bearing and new seal into the wheel.
15. Apply a thread-locking compound to the second spacer nut, and thread it onto the axle with the wrench flats facing outward.
16. Torque the nut to 8 to 9 N·m (75 to 80 in-lb), loosen the nut, then torque it to 2 to 3 N·m (20 to 25 in-lb).

Note: Make sure that the axle does not extend beyond either nut.

17. Install the seal guards over the wheel hub, and insert the wheel into the caster fork.
18. Install the caster bolt and tighten the nut fully.

Important: To prevent seal and bearing damage, check the bearing adjustment often. Spin the caster tire. The tire should not spin freely (more than 1 or 2 revolutions) or have any side play. If the wheel spins freely, adjust the torque on the spacer nut until there is a slight amount of drag. Apply another layer of thread-locking compound.

Engine Maintenance

Engine Safety

- Keep your hands, feet, face, clothing, and other body parts away from the muffler and other hot

surfaces. Allow engine components to cool before performing maintenance.

- Do not change the engine governor speed or overspeed the engine.

Identifying the Engine

Use the following graphic to identify the engine you have and proceed to the section listed below for service ([Figure 51](#)).

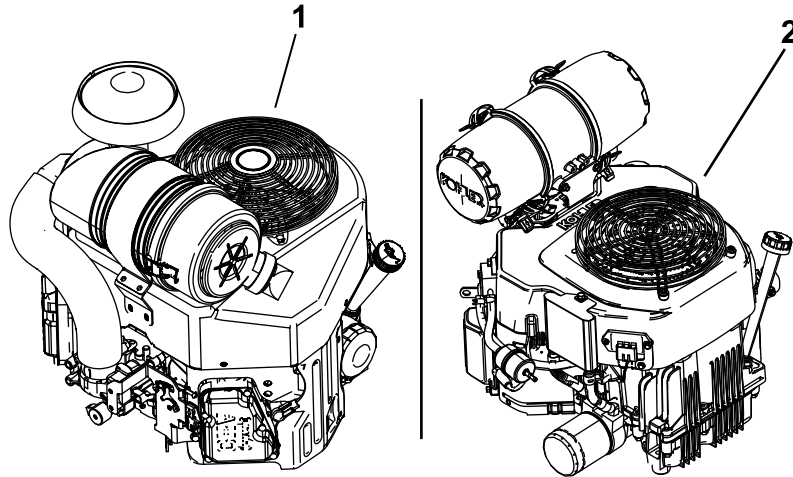

Figure 51

g230252

1. Kawasaki engine

2. Kohler engine

-
- For Kawasaki engine maintenance, refer to [Servicing a Kawasaki® Engine \(page 45\)](#).
 - For Kohler engine maintenance, refer to [Servicing a Kohler® Engine \(page 50\)](#).

Servicing a Kawasaki® Engine

This section is only for machines with Kawasaki engines. If your engine looks like the one shown in [Figure 52](#), you have a Kawasaki engine.

Important: Refer to your engine owner's manual for additional maintenance procedures.

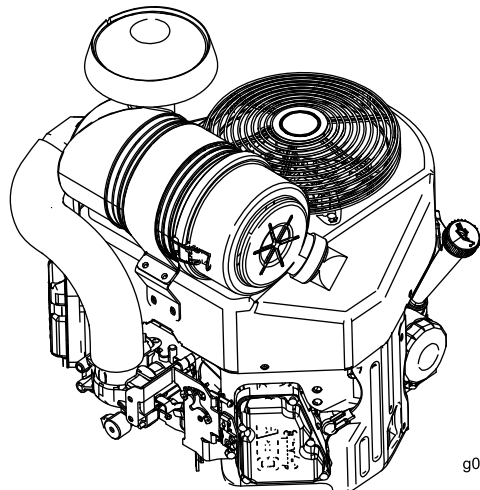

Figure 52

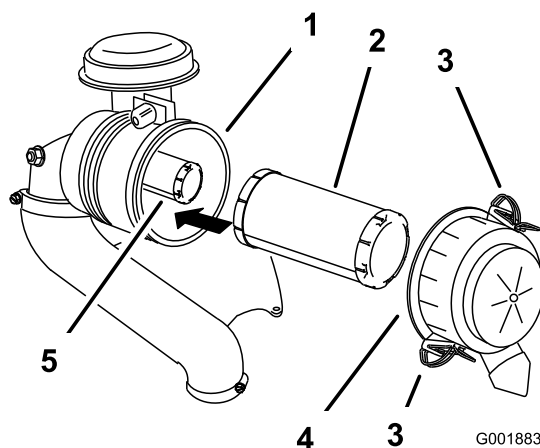

Figure 53

1. Air-cleaner body
2. Primary filter
3. Latch
4. Air-cleaner cover
5. Safety filter

4. Clean the inside of the air-cleaner cover with compressed air.
5. Gently slide the primary filter out of the air-cleaner body ([Figure 53](#)).

Note: Avoid knocking the filter into the side of the body.

6. Remove the safety filter only to replace it.

Servicing the Air Cleaner

Service Interval: Every 250 hours—For Kawasaki engines—replace the primary air filter (more often in dirty or dusty conditions).

Every 250 hours—For Kawasaki engines—check the safety air filter (more often in dirty or dusty conditions).

Every 500 hours—For Kawasaki engines—replace the safety air filter (more often in dirty or dusty conditions).

Note: Service the air cleaner more frequently if operating conditions are extremely dusty or sandy.

Removing the Filters

1. Park the machine on a level surface, disengage the blade-control switch (PTO), and engage the parking brake.
2. Shut off the engine, remove the key, and wait for all moving parts to stop before leaving the operating position.
3. Release the latches on the air cleaner and pull the air-cleaner cover off the air-cleaner body ([Figure 53](#)).

Inspecting the Filters

1. Inspect the safety filter. If it is dirty, replace both the safety and primary filters.

Important: Do not attempt to clean the safety filter. If the safety filter is dirty, then the primary filter is damaged.

2. Inspect the primary filter for damage by looking into the filter while shining a bright light on the outside of the filter. If the primary filter is dirty, bent, or damaged, replace it.

Note: Holes in the filter appear as bright spots. Do not clean the primary filter.

Installing the Filters

Important: To prevent engine damage, always operate the engine with both air filters and the cover installed.

1. If you are installing new filters, check each filter for shipping damage.

Note: Do not use a damaged filter.

2. If you are replacing the inner filter, carefully slide it into the filter body ([Figure 53](#)).

- Carefully slide the primary filter over the safety filter (Figure 53).

Note: Ensure that the primary filter is fully seated by pushing on the outer rim while installing it.

Important: Do not press on the soft, inside area of the filter.

- Install the air-cleaner cover and secure the latches (Figure 53).

Servicing the Engine Oil

Service Interval: Before each use or daily

Every 100 hours (more often in dirty or dusty conditions).

Every 200 hours—For Kawasaki engines—change the engine-oil filter (more often in dirty or dusty conditions).

Engine-Oil Specifications

Oil Type: Detergent oil (API service SF, SG, SH, SJ, or SL)

Crankcase Capacity:

- Models 72932, 72936, 72949, 72949HD, and 72950—2.3 L (78 fl oz) with a filter change; 2.1 L (71 fl oz) without a filter change
- Model 72952—2.1 L (71 fl oz) with a filter change; 1.8 L (61 fl oz) without a filter change

Viscosity: See the table below.

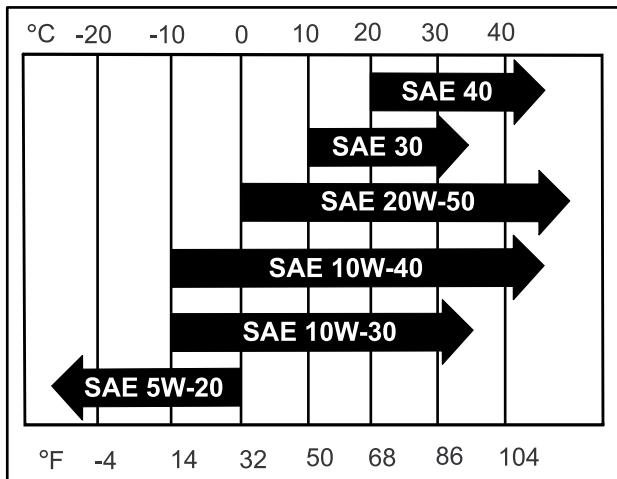

Figure 54

Note: Although 10W-40 engine oil is recommended for most conditions, you may need to change oil viscosity to accommodate atmospheric conditions. Using 20W-50 engine oil in higher ambient temperatures can reduce oil consumption.

Checking the Engine-Oil Level

Note: Check the oil when the engine is cold.

Important: If you overfill or underfill the engine crankcase with oil and run the engine, you may damage the engine.

- Park the machine on a level surface, disengage the blade-control switch (PTO), and engage the parking brake.
- Shut off the engine, remove the key, and wait for all moving parts to stop before leaving the operating position.

Note: Ensure that the engine is cool so that the oil has had time to drain into the sump.

- To keep dirt, grass clippings, etc., out of the engine, clean the area around the oil-fill cap and dipstick before removing it (Figure 55).

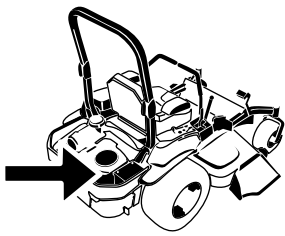

G008804
g008804

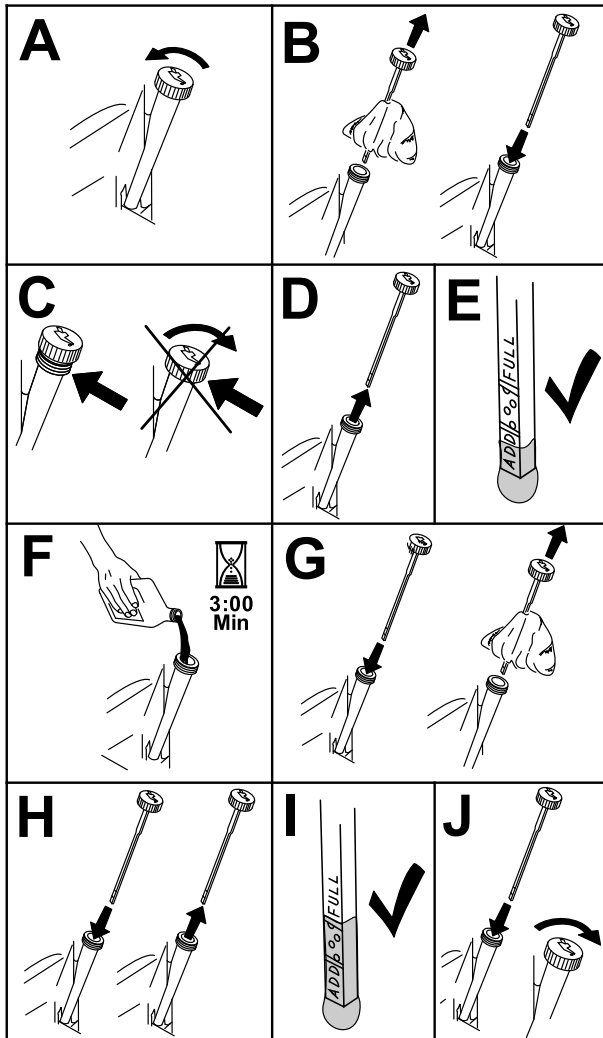
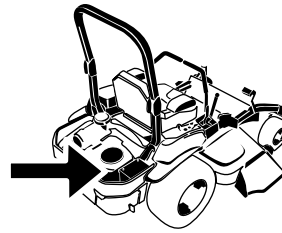

Figure 55

g194611

4. Shut off the engine, remove the key, and wait for all moving parts to stop before leaving the operating position.
5. Drain the oil from the engine (Figure 56).



G008804
g008804

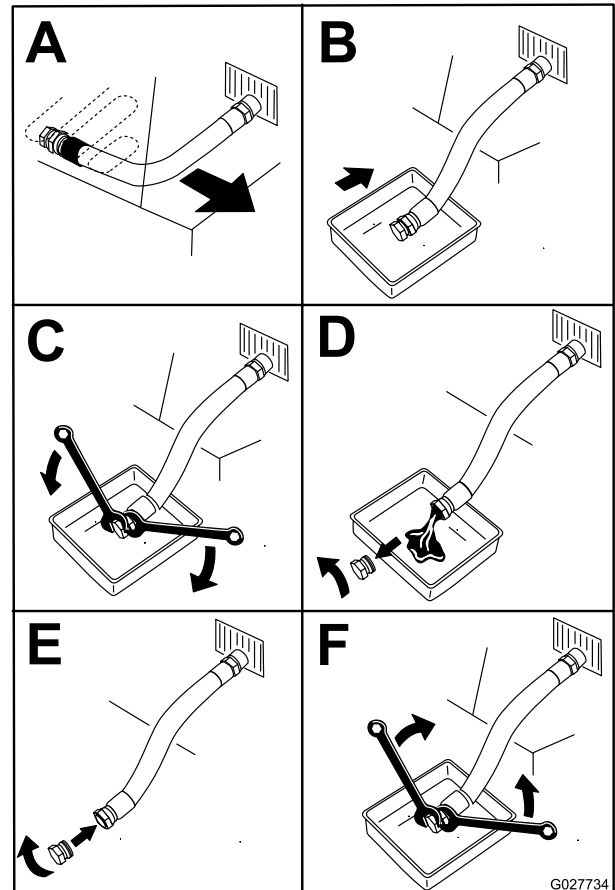

Figure 56

G027734

Changing the Engine Oil

Note: Dispose of the used oil at a recycling center.

1. Start the engine and let it run for 5 minutes.
 - Note:** This warms the oil so that it drains better.
2. Park the machine so that the drain side is slightly lower than the opposite side to ensure that the oil drains completely.
3. Disengage the blade-control switch (PTO) and engage the parking brake.

- Slowly pour approximately 80% of the specified oil into the filler tube and slowly add the additional oil to bring it to the Full mark (Figure 57).

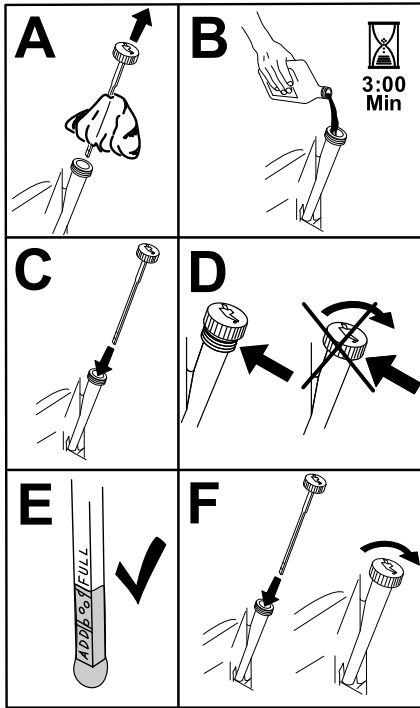

Figure 57

g194610

- Start the engine and drive to a flat area.
- Check the oil level again.

Changing the Engine-Oil Filter

- Drain the oil from the engine; refer to [Changing the Engine Oil \(page 47\)](#).
- Change the engine-oil filter (Figure 58).

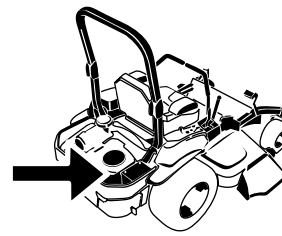

G008804
g008804

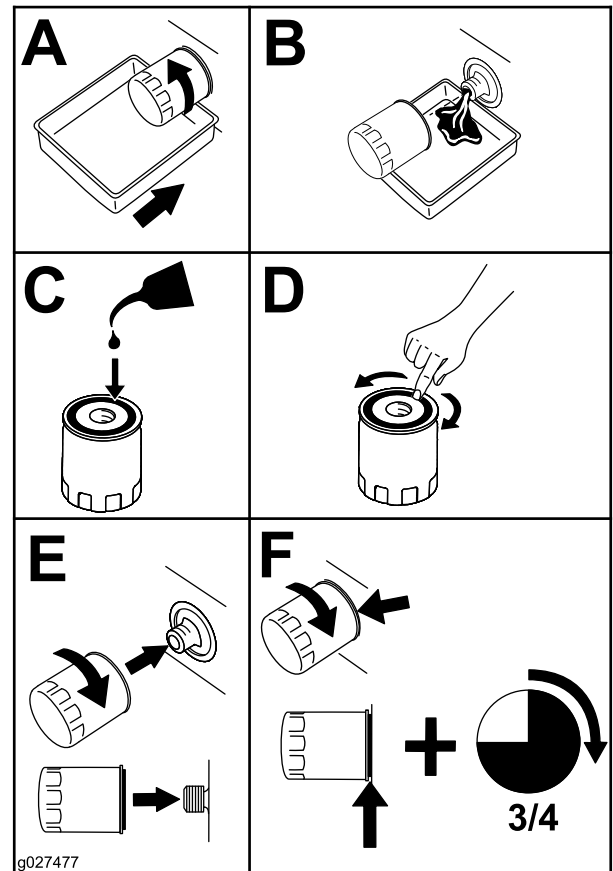

Figure 58

g027477

g027477

Note: Ensure that the oil-filter gasket touches the engine, and then turn the oil filter an extra 3/4 turn.

- Fill the crankcase with the proper type of new oil; refer to [Changing the Engine Oil \(page 47\)](#).

Servicing the Spark Plug(s)

Service Interval: Every 100 hours

Ensure that the air gap between the center and side electrodes is correct before installing the spark plug. Use a spark plug wrench for removing and installing the spark plug and a gapping tool or feeler gauge to check and adjust the air gap. Install a new spark plug if necessary.

Type of Spark Plug: NGK® BPR4ES or equivalent

Air Gap: 0.75 mm (0.03 inch)

Removing the Spark Plug(s)

1. Park the machine on a level surface, disengage the blade-control switch (PTO), and engage the parking brake.
2. Shut off the engine, remove the key, and wait for all moving parts to stop before leaving the operating position.
3. Clean the area around the base of the plug to keep dirt and debris out of the engine.
4. Locate and remove the spark plug(s) as shown in [Figure 59](#).

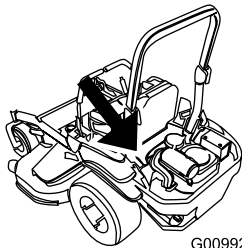

g009922

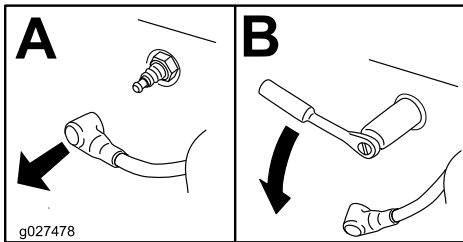

Figure 59

g027478

Checking the Spark Plug(s)

Important: Do not clean the spark plug(s). Always replace the spark plug(s) when it has a black coating, worn electrodes, an oily film, or cracks.

If you see light brown or gray on the insulator, the engine is operating properly. A black coating on the insulator usually means the air cleaner is dirty.

Set the gap to 0.75 mm (0.03 inch).

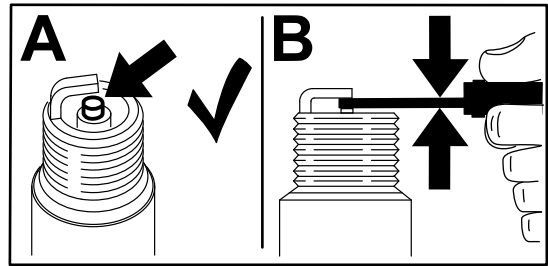

Figure 60

g206628

Installing the Spark Plug(s)

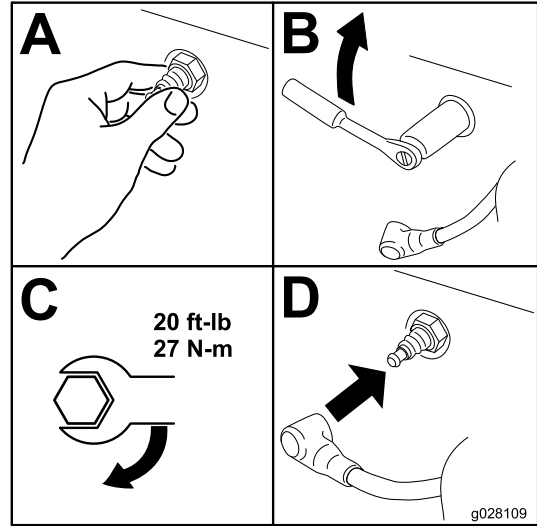

Figure 61

g028109

Servicing a Kohler® Engine

This section is only for machines with Kohler engines. If your engine looks like the one shown in [Figure 62](#), you have a Kohler engine.

Important: Refer to your engine owner's manual for additional maintenance procedures.

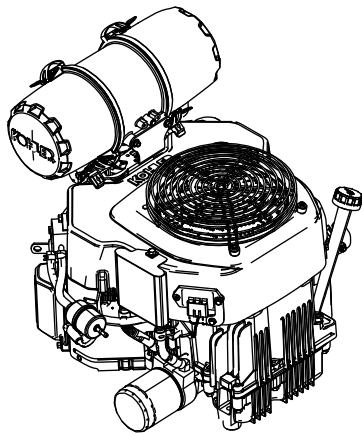
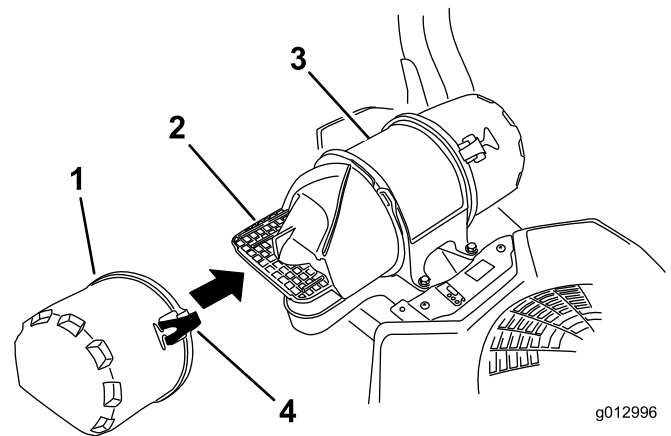

Figure 62

g230254



g012996

g012996

Figure 63

- | | |
|---------------------|---------------------|
| 1. Air-inlet cover | 3. Air-cleaner body |
| 2. Air-inlet screen | 4. Latch |

Servicing the Air Cleaner

Service Interval: Before each use or daily—For Kohler engines—check the air cleaner for dirty, loose or damaged parts.

Every 250 hours—For Kohler engines—service or replace the air-cleaner foam element (more often under dusty, dirty conditions).

Every 500 hours—For Kohler engines—replace the air-cleaner paper element (more often under dusty, dirty conditions).

Note: Service the air cleaner more frequently if operating conditions are extremely dusty or sandy.

Removing the Filters

1. Park the machine on a level surface, disengage the blade-control switch (PTO), and engage the parking brake.
2. Shut off the engine, remove the key, and wait for all moving parts to stop before leaving the operating position.
3. Release the latches on the air cleaner and pull the air-inlet cover off the air-cleaner body ([Figure 63](#)).
4. Clean the air-inlet screen and cover.
5. Install the air-inlet cover and secure it with the latches ([Figure 63](#)).

6. Release the latches on the air cleaner and pull the air-cleaner cover off the air-cleaner body ([Figure 64](#)).
7. Clean the inside of the air-cleaner cover with compressed air.
8. Gently slide the primary filter out of the air-cleaner body ([Figure 64](#)).

Note: Avoid knocking the filter into the side of the body.

9. Remove the inner filter only if you intend to replace it.

Important: Never attempt to clean the inner filter. If the safety filter is dirty, then the primary filter is damaged. Replace both filters.

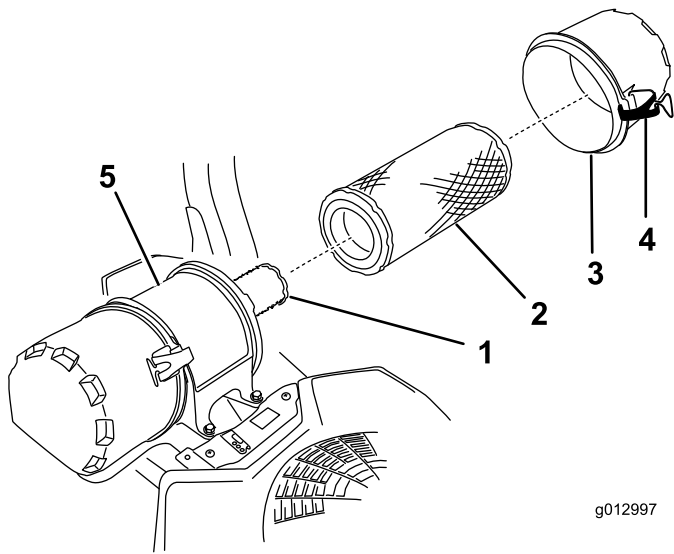

Figure 64

- | | |
|----------------------|---------------------|
| 1. Inner filter | 4. Latch |
| 2. Primary filter | 5. Air-cleaner body |
| 3. Air-cleaner cover | |

Installing the Filters

Important: To prevent engine damage, always operate the engine with both air filters and the cover installed.

- If you are installing new filters, check each filter for shipping damage.
- If you are replacing the inner filter, carefully slide it into the filter body (Figure 64).
- Carefully slide the primary filter over the safety filter (Figure 64).

Note: Ensure that the primary filter is fully seated by pushing on the outer rim while installing it.

Important: Do not press on the soft, inside area of the filter.

- Install the air-cleaner cover and secure the latches (Figure 64).

- Inspect the primary filter for damage by looking into the filter, while shining a bright light on the outside of the filter.

Note: Holes in the filter will appear as bright spots. If the filter is damaged, discard it.

Servicing the Foam Element

- Wash the foam element in liquid soap and warm water. When the element is clean, rinse it thoroughly.
- Dry the element by squeezing it in a clean cloth.

Important: Replace the foam element if it is torn or worn.

Servicing the Paper Element

- Gently tap the paper element to dislodge dirt.

Note: Do not wash the paper element or use pressurized air, as this will damage the element.

Note: Replace a dirty, bent, or damaged element. Handle the new element carefully; do not use if the sealing surfaces are bent or damaged.
- Clean the air-cleaner base as required, and check the condition.

Servicing the Engine Oil

Service Interval: Before each use or daily

Every 100 hours (more often in dirty or dusty conditions).

Every 200 hours—For Kohler engines—change the engine-oil filter (more often in dirty or dusty conditions).

Engine-Oil Specifications

Oil Type: Detergent oil (API service SJ or higher)

Oil Capacity: 1.8 L (61 fl oz) with a filter change; 1.6 L (54 fl oz) without a filter change

Viscosity: See the table below.

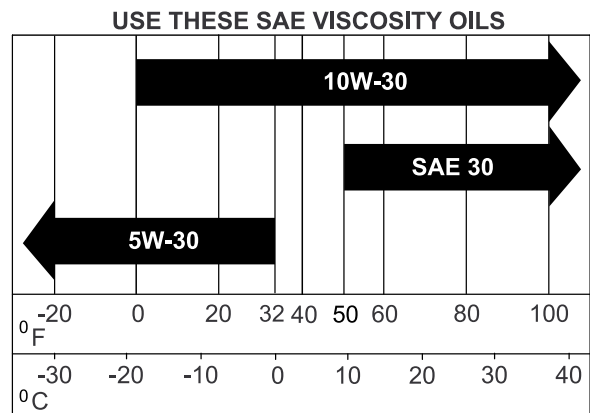

g017552

g017552

Figure 65

Checking the Engine-Oil Level

Note: Check the oil when the engine is cold.

Important: If you overfill or underfill the engine crankcase with oil and run the engine, you may damage the engine.

1. Park the machine on a level surface, disengage the blade-control switch (PTO), and engage the parking brake.
2. Shut off the engine, remove the key, and wait for all moving parts to stop before leaving the operating position.

Note: Ensure that the engine is cool so that the oil has had time to drain into the sump.

3. To keep dirt, grass clippings, etc., out of the engine, clean the area around the oil-fill cap and dipstick before removing it (Figure 55).

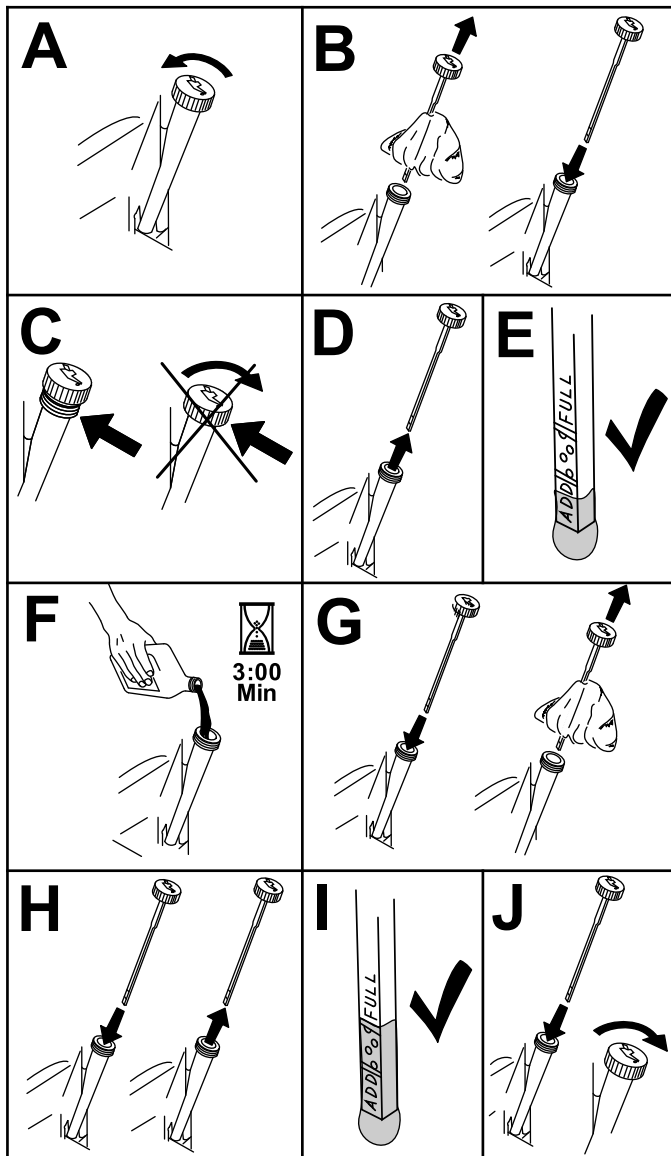

Figure 66

g194611

Changing the Engine Oil

Note: Dispose of the used oil at a recycling center.

1. Start the engine and let it run for 5 minutes.

Note: This warms the oil so that it drains better.
2. Park the machine so that the drain side is slightly lower than the opposite side to ensure that the oil drains completely.
3. Disengage the blade-control switch (PTO) and engage the parking brake.
4. Shut off the engine, remove the key, and wait for all moving parts to stop before leaving the operating position.
5. Drain the oil from the engine (Figure 67).

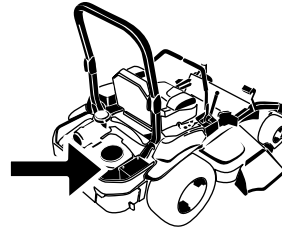

G008804
g008804

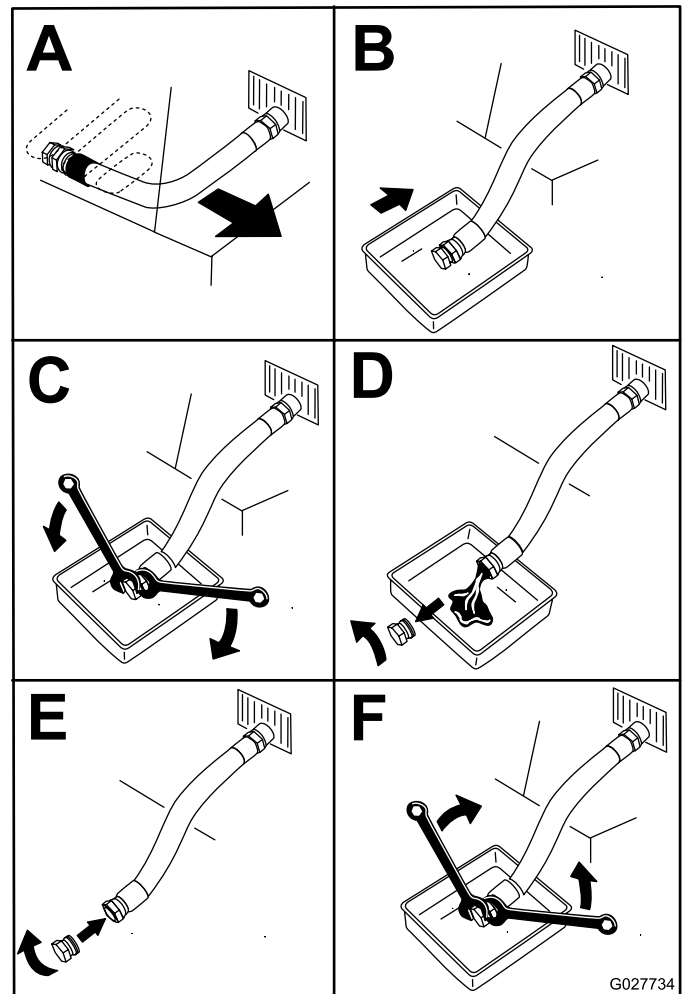

Figure 67

G027734
g027734

- Slowly pour approximately 80% of the specified oil into the filler tube and slowly add the additional oil to bring it to the Full mark (Figure 68).

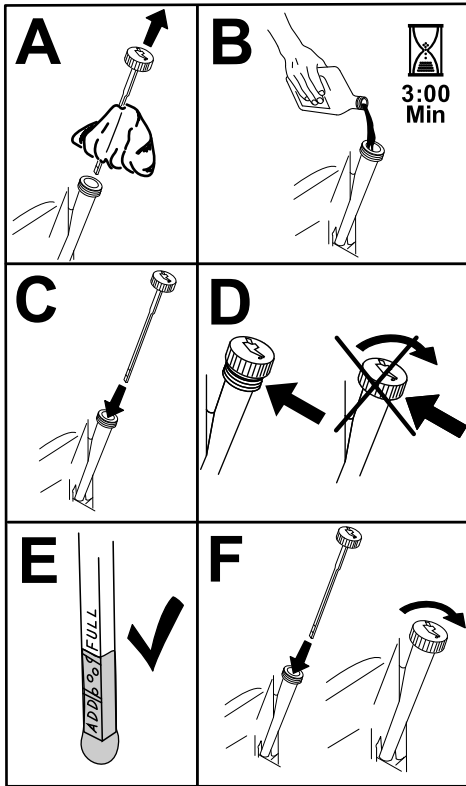

Figure 68

g194610

- Start the engine and drive to a flat area.
- Check the oil level again.

Changing the Engine-Oil Filter

Service Interval: Every 200 hours—For Kohler engines—change the engine-oil filter (more often in dirty or dusty conditions).

- Drain the oil from the engine; refer to [Changing the Engine Oil \(page 52\)](#).
- Change the engine-oil filter (Figure 69).

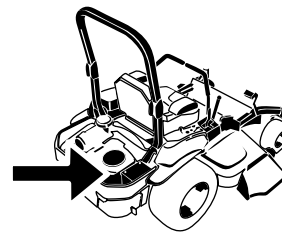

G008804
g008804

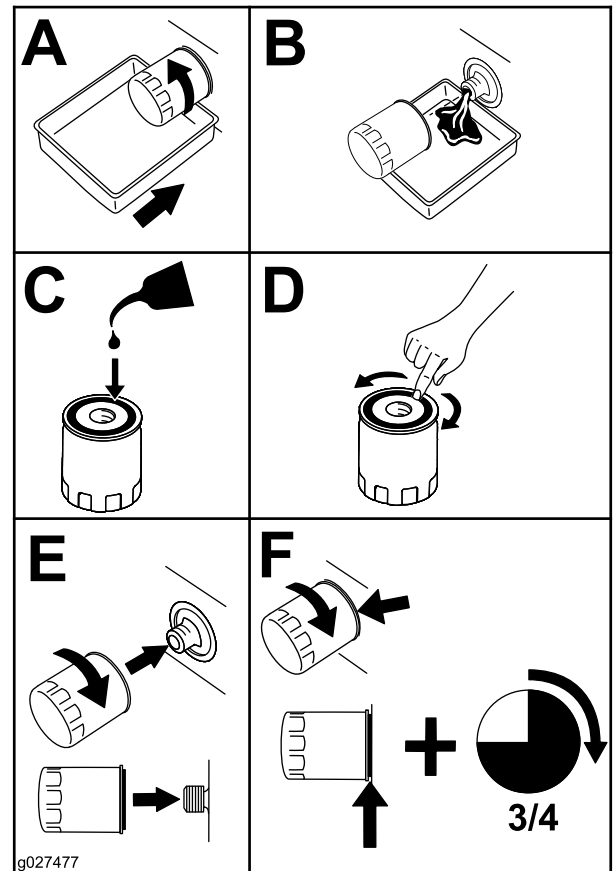

Figure 69

g027477

g027477

Note: Ensure that the oil-filter gasket touches the engine, and then turn the oil filter an extra 3/4 turn.

- Fill the crankcase with the proper type of new oil; refer to [Engine-Oil Specifications \(page 51\)](#).

Servicing the Spark Plug

Service Interval: Every 200 hours—For Kohler engines—check the spark plug(s).

Every 500 hours—For Kohler engines—replace the spark plug(s).

Type: Champion XC12YC

Air Gap: 0.76 mm (0.03 inch)

Removing the Spark Plug

1. Park the machine on a level surface, disengage the blade-control switch (PTO), and engage the parking brake.
2. Shut off the engine, remove the key, and wait for all moving parts to stop before leaving the operating position.
3. Clean the area around the base of the plug(s) to keep dirt and debris out of the engine.
4. Locate and remove the spark plug(s) as shown in Figure 70.

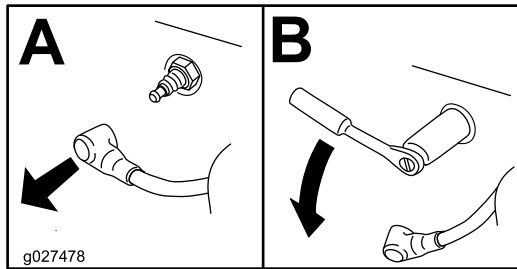
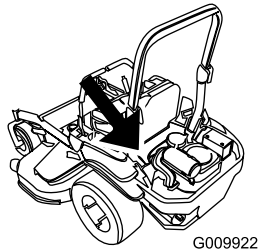

Figure 70

Installing the Spark Plug

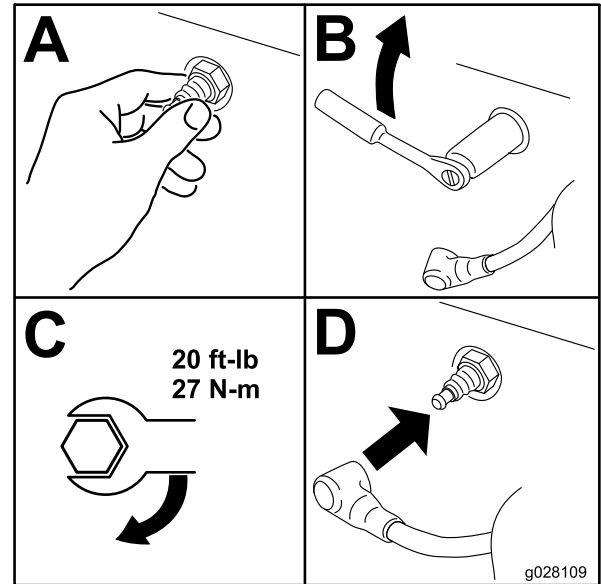

Figure 72

Checking the Spark Plug

Important: Do not clean the spark plug(s). Always replace the spark plug(s) when it has a black coating, worn electrodes, an oily film, or cracks.

If you see light brown or gray on the insulator, the engine is operating properly. A black coating on the insulator usually means the air cleaner is dirty.

Set the gap to 0.76 mm (0.03 inch).

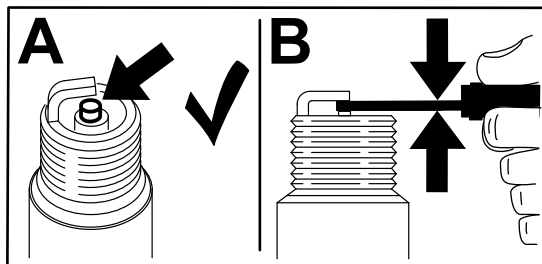

Figure 71

Checking the Spark Arrester

For Machines with a Spark Arrester

Service Interval: Every 50 hours

⚠ WARNING

Hot exhaust-system components may ignite fuel vapors even after you shut off the engine. Hot particles exhausted during engine operation may ignite flammable materials, resulting in personal injury or property damage.

Do not refuel or run the engine unless the spark arrester is installed.

1. Park the machine on a level surface, disengage the PTO, and engage the parking brake.
2. Shut off the engine, remove the key, and wait for all moving parts to stop before leaving the operating position.
3. Wait for the muffler to cool.
4. If you see any breaks in the screen or welds, replace the arrester.
5. If the screen is plugged, remove the arrester, shake loose particles out of the arrester, and clean the screen with a wire brush (soak the screen in solvent if necessary).
6. Install the arrester on the exhaust outlet.

Fuel System Maintenance

⚠ WARNING

Fuel-system components are under high pressure. The use of improper components can result in system failure, fuel leakage, and possible explosion.

Use only approved fuel lines and fuel filters.

Servicing the Electronic Fuel-Injection System

Machines with EFI Engines Only

This machine contains an electronic fuel-injection system. It controls the fuel flow under different operating conditions.

The electronic-control unit (ECU) continuously monitors the operation of the EFI system.

If a problem or fault within the system is detected, the LED status light illuminates. The MIL is the red light located on the right side of the hour meter.

Once the light illuminates, make initial troubleshooting checks; refer to the LED status light section under [Troubleshooting \(page 87\)](#).

If these checks do not correct the problem, further diagnosis and servicing by an Authorized Service Dealer is necessary.

Replacing the Low-Pressure Fuel Filter

Service Interval: Every 200 hours/Yearly (whichever comes first)

The fuel filter is located near the engine on the front or rear side of the engine.

1. Park the machine on a level surface, disengage the blade-control switch, and engage the parking brake.
2. Shut off the engine, remove the key, and wait for all moving parts to stop before leaving the operating position.
3. Wait for the machine to cool down.
4. Close the fuel-shutoff valve under the seat ([Figure 73](#)).

Electrical System Maintenance

Electrical System Safety

- Disconnect the battery before repairing the machine. Disconnect the negative terminal first and the positive last. Connect the positive terminal first and the negative last.
- Charge the battery in an open, well-ventilated area, away from sparks and flames. Unplug the charger before connecting or disconnecting the battery. Wear protective clothing and use insulated tools.

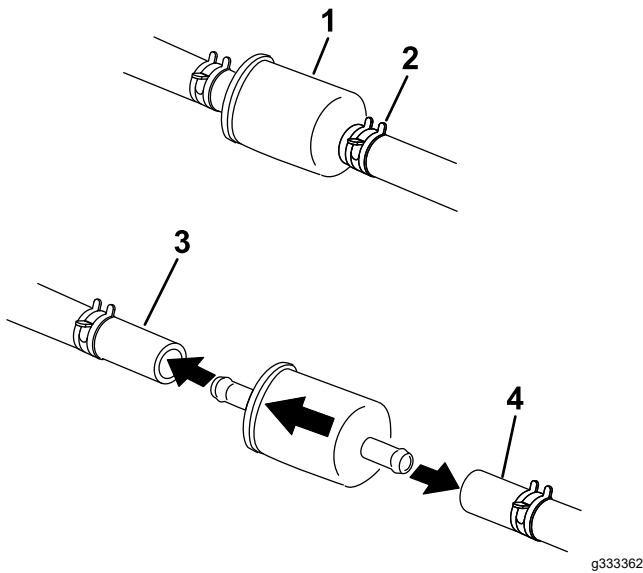

Figure 73

- | | |
|----------------|---------------------------------|
| 1. Fuel filter | 3. Fuel line to the engine |
| 2. Hose clamp | 4. Fuel line from the fuel tank |

5. Squeeze the ends of the hose clamps together and slide them away from the filter (Figure 73).
6. Remove the filter from the fuel lines.
7. Install a new filter and move the hose clamps close to the filter (Figure 73).
8. Open the fuel-shutoff valve.

Important: Install the fuel line hoses and secure with plastic ties the same as they were originally installed at the factory to keep the fuel line away from components that can cause fuel line damage.

Servicing the High-Pressure Fuel Filter

Do not attempt to service the high-pressure fuel filter. The high-pressure filter is integrated within the fuel-pump module. The fuel filter and other components inside the fuel-pump module are not serviceable.

Important: Do not attempt to open the fuel-pump module.

Ensure that an Authorized Service Dealer replaces the fuel-pump module with the high-pressure fuel filter.

Servicing the Fuel Tank

Do not attempt to drain the fuel tank. Ensure that an Authorized Service Dealer drains the fuel tank and services any components of the fuel system.

Servicing the Battery

Service Interval: Monthly

Removing the Battery

⚠ WARNING

Battery terminals or metal tools could short against metal machine components causing sparks. Sparks can cause the battery gasses to explode, resulting in personal injury.

- When removing or installing the battery, do not allow the battery terminals to touch any metal parts of the machine.
- Do not allow metal tools to short between the battery terminals and metal parts of the machine.

⚠ WARNING

Incorrectly removing the cables from battery could damage the machine and cables, causing sparks. Sparks can cause the battery gasses to explode, resulting in personal injury.

- Always disconnect the negative (black) battery cable before disconnecting the positive (red) cable.
- Always connect the positive (red) battery cable before connecting the negative (black) cable.

1. Park the machine on a level surface, disengage the blade-control switch (PTO), and engage the parking brake.

2. Shut off the engine, remove the key, and wait for all moving parts to stop before leaving the operating position.
3. Remove the battery as shown in [Figure 74](#).

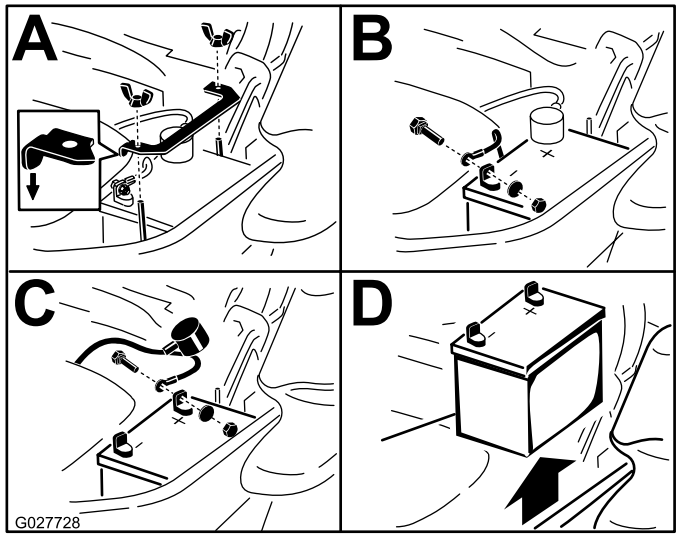

Figure 74

Charging the Battery

⚠ WARNING

Charging the battery produces gasses that can explode.

Never smoke near the battery and keep sparks and flames away from the battery.

Important: Always keep the battery fully charged (1.265 specific gravity). This is especially important to prevent battery damage when the temperature is below 0°C (32°F).

1. Remove the battery from the chassis; refer to [Removing the Battery \(page 56\)](#).
2. Charge the battery for 10 to 15 minutes at 25 to 30 A or for 30 minutes at 10 A.

Note: Do not overcharge the battery.

3. When the battery is fully charged, unplug the charger from the electrical outlet, then disconnect the charger leads from the battery posts ([Figure 75](#)).
4. Install the battery in the machine and connect the battery cables; refer to [Installing the Battery \(page 58\)](#).

Note: Do not run the machine with the battery disconnected; electrical damage may occur.

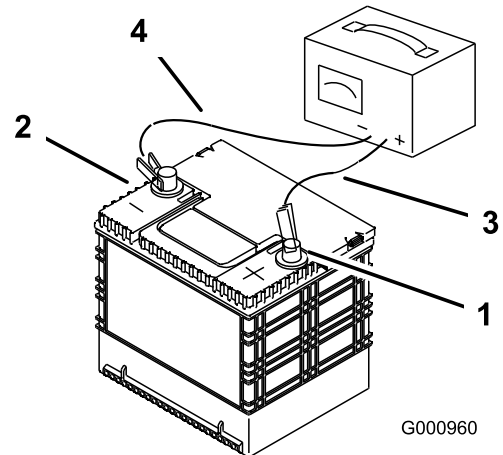

Figure 75

- | | |
|------------------------------|---------------------------|
| 1. Positive (+) battery post | 3. Red (+) charger lead |
| 2. Negative (-) battery post | 4. Black (-) charger lead |

Installing the Battery

Note: Position the battery in the tray with the terminal posts opposite from the hydraulic tank (Figure 76).

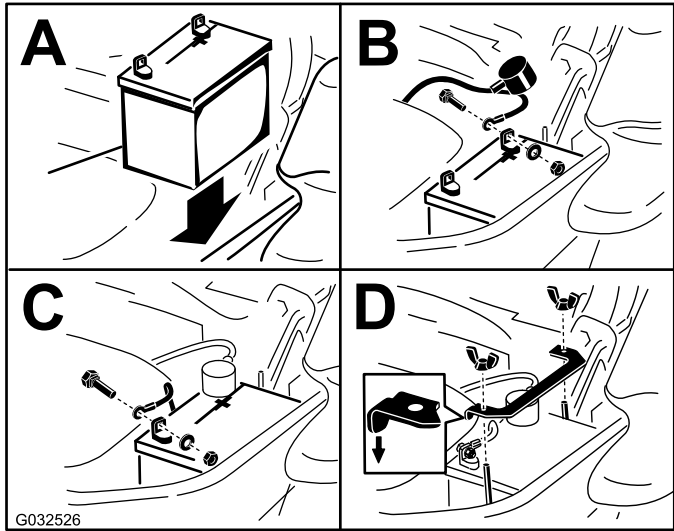

Figure 76

Servicing the Fuses

For Machines with a Standard Hour Meter

The electrical system is protected by fuses. It requires no maintenance, however, if a fuse blows check the component/circuit for a malfunction or short.

The fuses are located on the console to the right of the seat (Figure 77).

1. To replace the fuses, pull out on the fuse to remove it.
2. Install a new fuse (Figure 77).

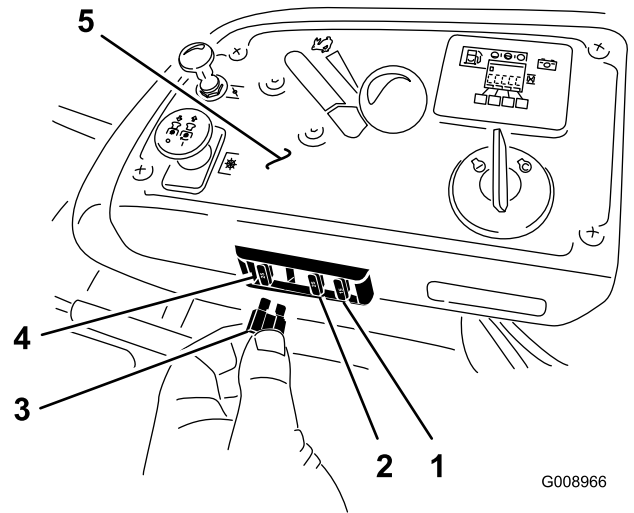

Figure 77

1. Optional accessory (15 A)
2. Charge (25 A)
3. PTO (10 A)
4. Main (25 A)
5. Console

Servicing the Fuses

For Machines with a Smart Hour Meter

The electrical system is protected by fuses. It requires no maintenance, however, if a fuse blows check the component/circuit for a malfunction or short. The fuses are located on the console to the right of the seat (Figure 78).

To replace the fuses, remove the cover, pull out on the fuse to remove it, and install a new fuse.

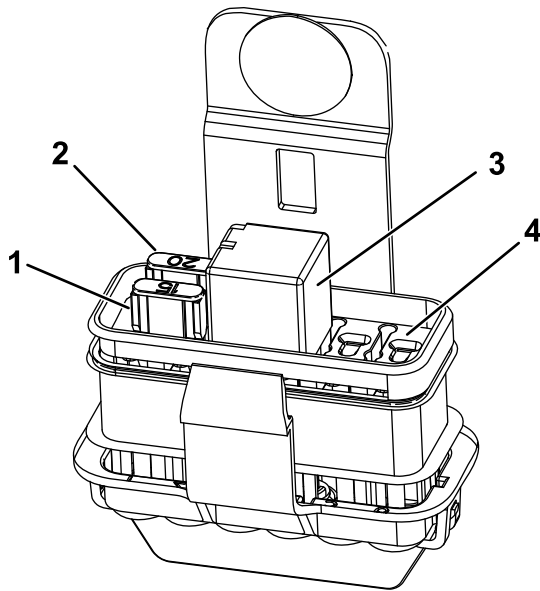

Figure 78

g231345

- | | |
|--------------------|----------------|
| 1. Auxiliary, 15 A | 3. Start relay |
| 2. Main, 20 A | 4. Open |

Jump-Starting the Machine

1. Check and clean corrosion from the battery terminals before jump-starting. Ensure that the connections are tight.

⚠ CAUTION

Corrosion or loose connections can cause unwanted electrical voltage spikes at any time during the jump-starting procedure.

Do not attempt to jump-start the machine with loose or corroded battery terminals, or damage to the engine or EFI may occur.

⚠ DANGER

Jump-starting a weak battery that is cracked or frozen or has a low electrolyte level or an open/shorted battery cell can cause an explosion, resulting in serious personal injury.

Do not jump-start a weak battery if these conditions exist.

2. Make sure that the booster battery is a good and fully charged lead-acid battery at 12.6 V or greater.

Note: Use properly sized jumper cables with short lengths to reduce voltage drop between systems. Make sure that the cables are color coded or labeled for the correct polarity.

⚠ CAUTION

Connecting the jumper cables incorrectly (wrong polarity) can immediately damage the EFI system.

Be certain of battery-terminal polarity and jumper-cable polarity when hooking up the batteries.

⚠ WARNING

Batteries contain acid and produce explosive gases.

- Shield your eyes and face from the batteries at all times.
- Do not lean over the batteries.

Note: Ensure that the vent caps are tight and level. Place a damp cloth, if available, over any vent caps on both batteries. Also ensure that the machines do not touch and that both electrical systems are off and at the same rated system voltage. These instructions are for negative ground systems only.

3. Connect the positive (+) cable to the positive (+) terminal of the discharged battery that is wired to the starter or solenoid as shown in Figure 79.

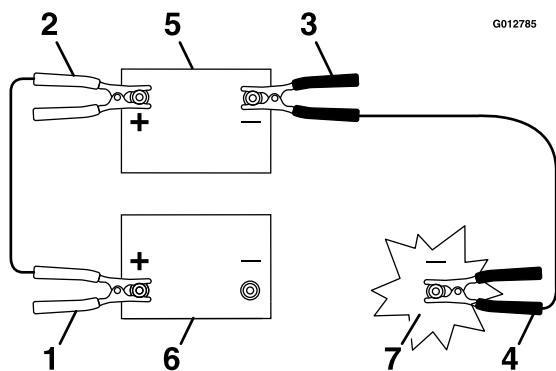
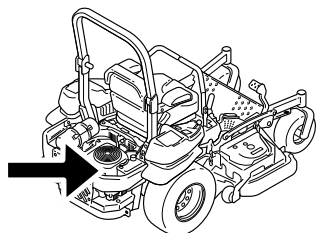

Figure 79

- | | |
|--|-----------------------|
| 1. Positive (+) cable on discharged battery | 5. Booster battery |
| 2. Positive (+) cable on booster battery | 6. Discharged battery |
| 3. Negative (-) cable on the booster battery | 7. Engine block |
| 4. Negative (-) cable on the engine block | |

- Connect the other end of the positive cable to the positive terminal of the booster battery.
- Connect the black negative (-) cable to the other terminal (negative) of the booster battery.
- Make the final connection on the engine block of the stalled machine (not to the negative battery post), away from the battery, and stand back (Figure 80).



g024213
g024213

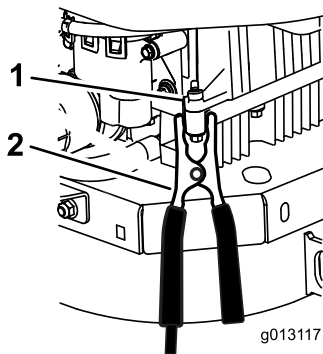

Figure 80

- | | |
|-----------------|-----------------------|
| 1. Engine block | 2. Negative (-) cable |
|-----------------|-----------------------|

- Start the machine and remove the cables in the reverse order of connection (disconnect the negative cable from the engine block first).

Drive System Maintenance

Checking the Seat Belt

Service Interval: Before each use or daily

Inspect the seat belt for wear, cuts, and proper operation of the retractor and buckle. Replace the seat belt if it is damaged.

Checking the Roll-Bar Knobs

Service Interval: Before each use or daily

⚠ WARNING

To avoid injury or death from rollover, keep the roll bar in the fully raised, locked position and use the seat belt.

Ensure that the seat is secured to the machine.

- Check that both the mounting hardware and the knobs are in good working condition.
- Make sure that the knobs are fully engaged with the roll bar in the raised position.

Note: The upper hoop of the roll bar may need to be pushed forward or pulled rearward to fully engage both knobs (Figure 81 and Figure 82).

Adjusting the Tracking

1. Disengage the blade-control switch (PTO).
2. Drive to an open flat area, move the motion-control levers to the NEUTRAL-LOCK position.
3. Move the throttle midway between the FAST and SLOW positions.
4. Move both motion-control levers all the way forward until they both hit the stops in the T-slot.
5. Check which way the machine tracks.
6. Engage the parking brake, shut off the engine, and remove the key.
7. Adjust the stop plates as needed.
 - If the machine tracks to the right, loosen the bolts and adjust the left stop plate rearward on the left T-slot until the machine tracks straight (Figure 83).
 - If the machine tracks to the left, loosen the bolts and adjust the right stop plate rearward on the right T-slot until the machine tracks straight (Figure 83).
8. Tighten the stop plate (Figure 83).

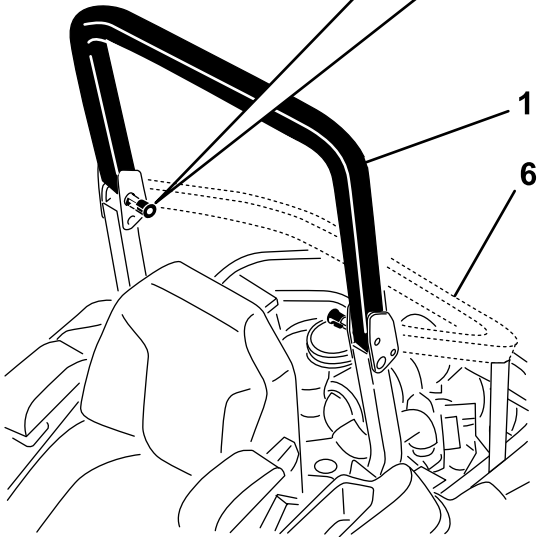
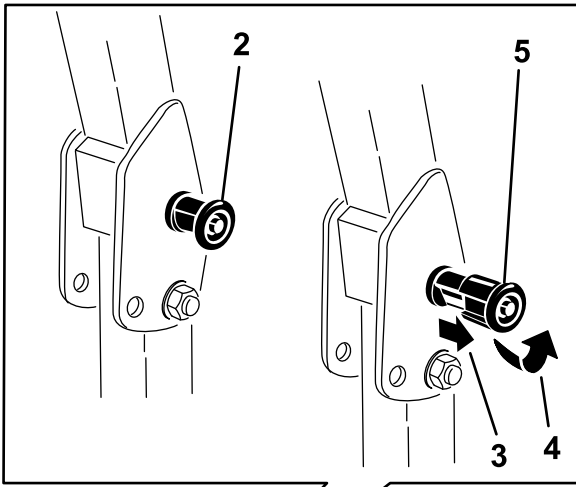

Figure 81

g228804

- | | |
|--|---|
| <ol style="list-style-type: none"> 1. Roll bar in the upright position 2. Roll-bar knob in the latched position 3. Pull the roll-bar knob out and rotate it 90 degrees. | <ol style="list-style-type: none"> 4. Rotate the roll-bar knob 90 degrees. 5. Roll-bar knob in the unlatched position 6. Roll bar in the folded position |
|--|---|

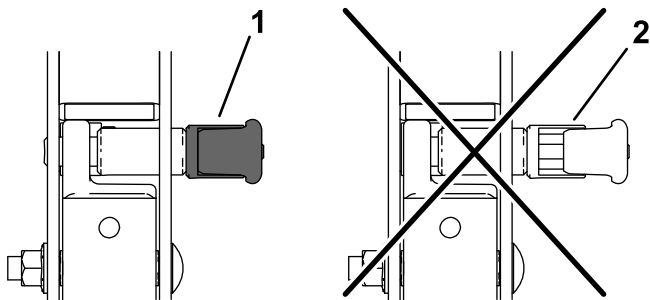

Figure 82

g228981

- | | |
|--|---|
| <ol style="list-style-type: none"> 1. Engaged | <ol style="list-style-type: none"> 2. Partially engaged—do not operate with the roll bar in this position. |
|--|---|

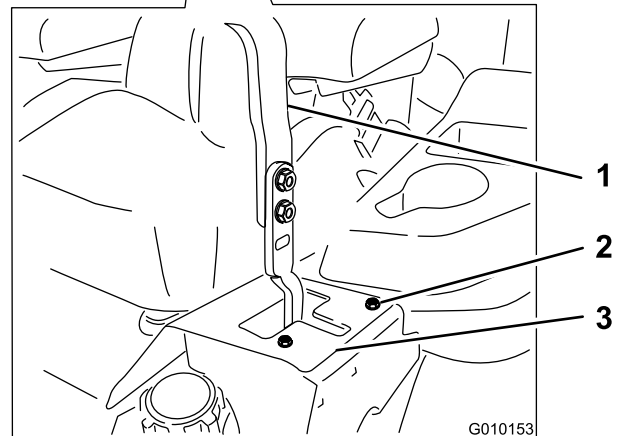
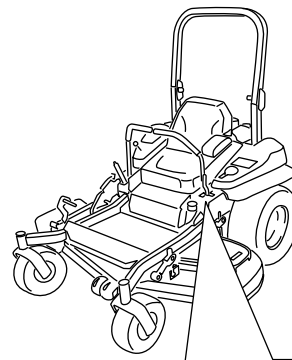

Figure 83
Left control lever shown

G010153

g010153

- | | |
|---|---|
| <ol style="list-style-type: none"> 1. Control lever 2. Bolt | <ol style="list-style-type: none"> 3. Stop plate |
|---|---|

Checking the Tire Pressure For Machines with Pneumatic Tires Only

Service Interval: Every 50 hours/Monthly (whichever comes first) For machines with pneumatic tires only.

Maintain the air pressure in the rear tires at 90 kPa (13 psi). Uneven tire pressure can cause uneven cut. Check the tires when they are cold to get the most accurate pressure reading.

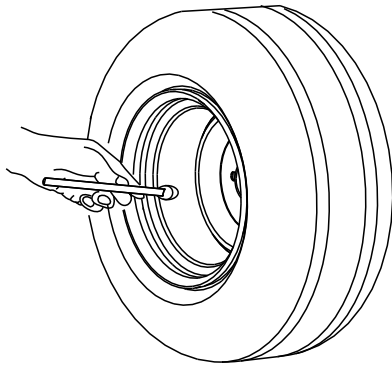

G001055

Figure 84

g001055

Checking the Wheel Lug Nuts

Check and torque the wheel lug nuts to 122 to 129 N·m (90 to 95 ft-lb).

Checking the Wheel-Hub Slotted Nut

Service Interval: After the first 100 hours

Every 500 hours

Check and ensure that the torque of the slotted nut is 286 to 352 N·m (211 to 260 ft-lb).

Note: Do not use anti-seize compound on wheel hub.

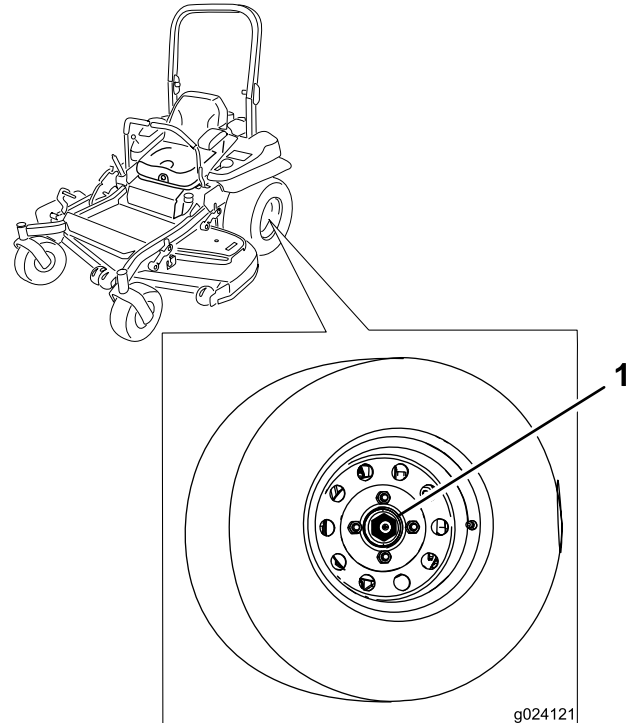

g024121

Figure 85

g024121

1. Slotted nut

Adjusting the Caster-Pivot Bearing

Service Interval: Every 500 hours/Yearly (whichever comes first)

1. Park the machine on a level surface, disengage the blade-control switch (PTO), and engage the parking brake.
2. Shut off the engine, remove the key, and wait for all moving parts to stop before leaving the operating position.
3. Remove the dust cap from caster and tighten the locknut (Figure 86).
4. Tighten the locknut until the spring washers are flat, and then back off a 1/4 turn to properly set the preload on the bearings (Figure 86).

Important: Make sure that the spring washers are installed correctly as shown in Figure 86.

5. Install the dust cap (Figure 86).

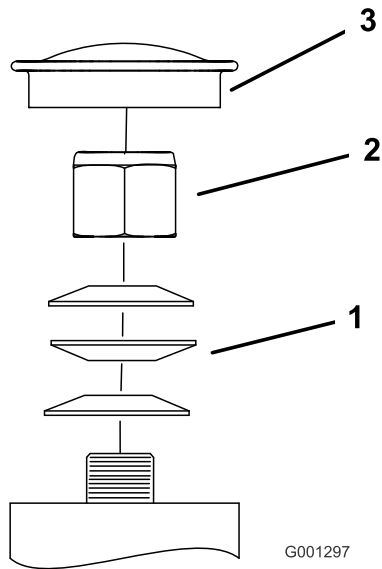

Figure 86

- | | |
|-------------------|-------------|
| 1. Spring washers | 3. Dust cap |
| 2. Locknut | |

Removing the Clutch Shim

Some later model year units have been built with clutches that contain a brake shim. When the clutch brake has worn to the point where the clutch no longer engages consistently, you can remove the shim to extend the clutch life.

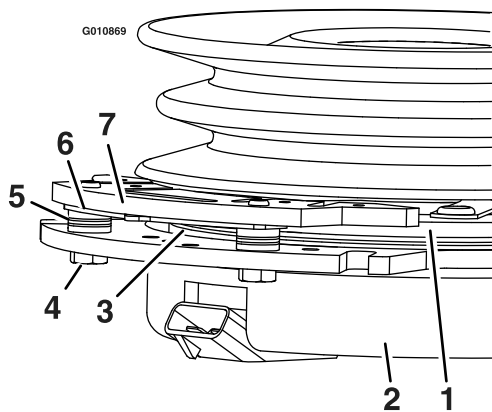

Figure 87

- | | |
|------------------------|-----------------|
| 1. Armature | 5. Brake spacer |
| 2. Field shell | 6. Re-gap shim |
| 3. Rotor | 7. Brake pole |
| 4. Brake-mounting bolt | |

1. Park the machine on a level surface, disengage the blade-control switch (PTO), and engage the parking brake.
2. Shut off the engine, remove the key, and wait for all moving parts to stop before leaving the operating position.
3. Using an air compressor, blow out any debris from under the brake pole and around the brake spacers (Figure 88).

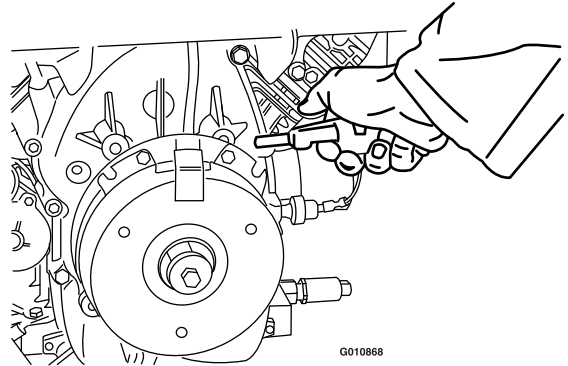

Figure 88

4. Check the condition of the wire-harness leads, connectors, and terminals.

Note: Clean or repair as necessary.

5. Verify that 12 V is present at the clutch connector when the blade-control switch (PTO) switch is engaged.
6. Measure the gap between the rotor and armature. If the gap is greater than 1 mm (0.04 inch), do the following steps:
 - A. Loosen both brake-mounting bolts 1/2 to 1 full turn as shown in Figure 89.

Note: Do not remove the brake pole from the field shell/armature. The brake pole has worn to match the armature and needs to continue to match after you remove the shim to ensure proper brake torque.

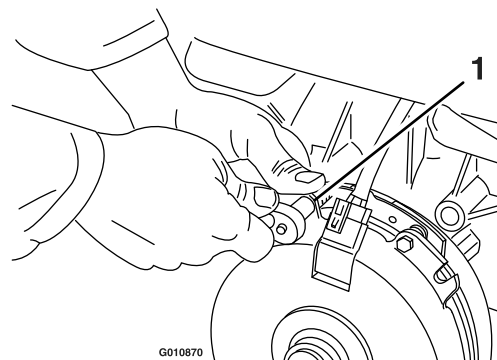

Figure 89

1. Brake-mounting bolt

- B. Using needle-nose pliers, or by hand, hold the tab and remove the shim (Figure 90).

Note: Do not discard the shim until the clutch is functioning properly.

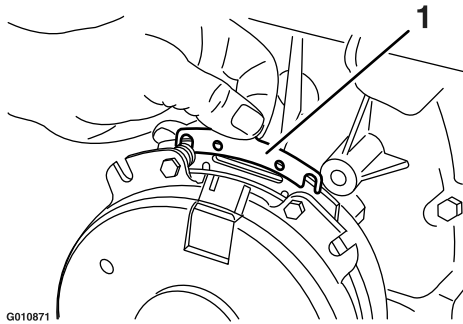

Figure 90

1. Shim

- C. Using a pneumatic line, blow out any debris from under the brake pole and around the brake spacers.
- D. Torque each bolt (M6 x 1) to 12.3 to 13.7 N·m (9.5 to 10.5 ft-lb).
- E. Using a 0.25 mm (0.01 inch) thick feeler gauge, verify that a gap is present between the rotor and the armature face on both sides of the brake pole as shown in Figure 91 and Figure 92.

Note: Due to the way the rotor and the armature faces wear (peaks and valleys) it is sometimes difficult to measure the gap accurately.

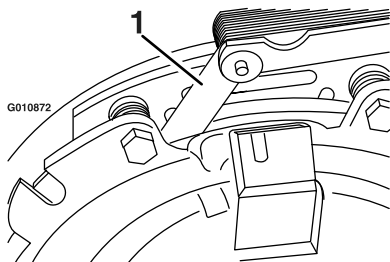

Figure 91

1. Feeler gauge

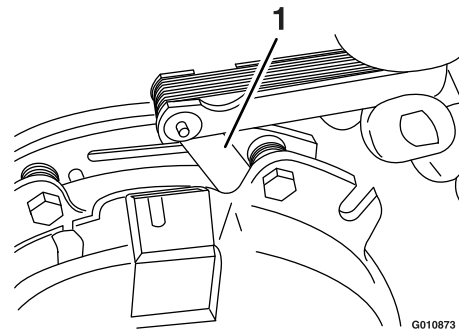

Figure 92

1. Feeler gauge

- If the gap is less than 0.25 mm (0.01 inch), then install the shim.
- If the gap is sufficient, proceed to the safety check in step F.

- F. Perform the following safety check:

- i. Sit on the seat and start the engine.
- ii. Make sure that the blades do not engage with the blade-control switch (PTO) in the OFF position, and that the clutch is disengaged.

If the clutch does not disengage, install the shim again.

- iii. Engage and disengage the blade-control switch (PTO) 10 consecutive times to ensure that the clutch is functioning properly.

Cooling System Maintenance

Cooling System Safety

- Swallowing engine coolant can cause poisoning; keep out of reach from children and pets.
- Discharge of hot, pressurized coolant or touching a hot radiator and surrounding parts can cause severe burns.
 - Always allow the engine to cool at least 15 minutes before removing the radiator cap.
 - Use a rag when opening the radiator cap, and open the cap slowly to allow steam to escape.

Cleaning the Engine Screen and Engine-Oil Cooler

Service Interval: Before each use or daily

Remove any buildup of grass, dirt, or other debris from the oil cooler and the engine screen (Figure 93).

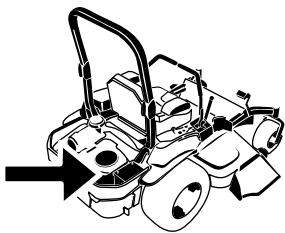

G008804
g008804

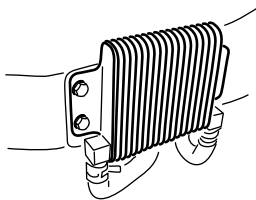

G009191

g009191

Figure 93

Remove any buildup of grass, dirt, or other debris from the engine screen. This helps ensure adequate cooling and correct engine speed and reduces the possibility of overheating and mechanical damage to the engine (Figure 90).

Cleaning the Engine-Cooling Fins and Shrouds

Service Interval: Every 100 hours/Yearly (whichever comes first)

1. Park the machine on a level surface, disengage the blade-control switch (PTO), and engage the parking brake.
2. Shut off the engine, remove the key, and wait for all moving parts to stop before leaving the operating position.
3. Remove the air-intake screen, the recoil starter, and the fan housing (Figure 94).
4. Clean the debris and grass from the engine parts.
5. Install the air-intake screen, the recoil starter, and the fan housing (Figure 94).

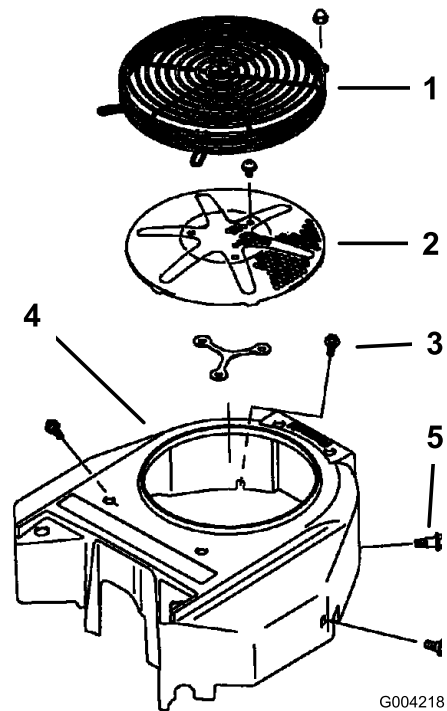

G004218

g004218

Figure 94

1. Engine guard
2. Engine air-intake screen
3. Bolt
4. Fan housing
5. Screw

Checking and Cleaning the Hydraulic-Unit Shrouds

Service Interval: Before each use or daily

1. Park the machine on a level surface, disengage the blade-control switch (PTO), and engage the parking brake.
2. Shut off the engine, remove the key, and wait for all moving parts to stop before leaving the operating position.
3. Move the seat forward.
4. Clean the debris and grass from the hydraulic-unit shrouds ([Figure 95](#)).
5. Position the seat.

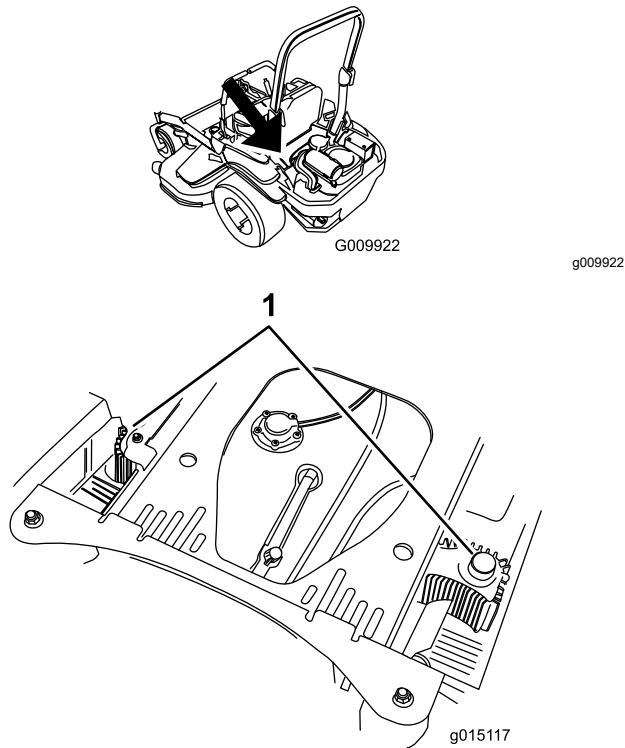

Figure 95

1. Hydraulic-unit shrouds

Brake Maintenance

Adjusting the Parking Brake

Service Interval: After the first 100 hours

Every 500 hours

Check to ensure that parking brake is adjusted properly. This procedure must be followed after the first 100 hours or when a brake component has been removed or replaced.

1. Park the machine on a level surface, disengage the blade-control switch, and engage the parking brake.
2. Shut off the engine, remove the key, and wait for all moving parts to stop before leaving the operating position.
3. Raise the rear of the machine up and support the machine with jack stands.
4. Remove the rear tires from the machine.
5. Remove any debris from the brake area.
6. Release the drive wheels; refer to [Using the Drive-Wheel-Release Valves](#) ([page 36](#)).
7. Disengage the parking brake.
8. Remove the spring clevis pin from the rear linkage and caliper ([Figure 96](#)).

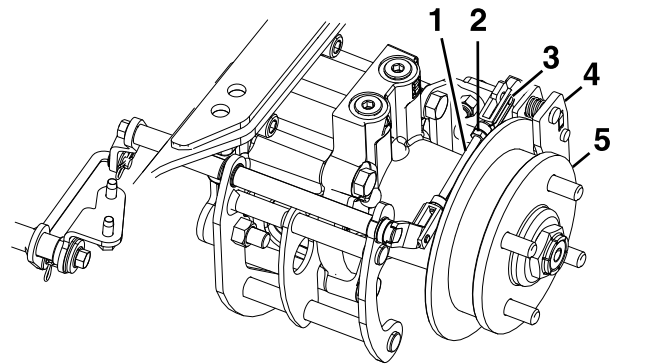

Figure 96

1. Rear linkage
2. Jam nut
3. Spring clevis pin
4. Caliper
5. Wheel hub

9. Loosen the jam nut on the rear linkage.
10. Push the caliper lever forward with finger pressure until the brake pad contacts the hub rotor.
11. Adjust the rear linkage until the spring clevis pin can be inserted in the hole in the caliper lever.

Note: To lengthen the linkage, rotate the clevis 1 turn outward.

12. Tighten the jam nut on the rear linkage ([Figure 96](#)).
13. Ensure that the wheel hub moves freely between the caliper brake pads.
14. Repeats steps 8 to 13 for the right side.
15. Rotate the drive wheel release handle to the operating position; refer to [Using the Drive-Wheel-Release Valves \(page 36\)](#).
16. Install the rear tires and torque the lug nuts to 129 N·m (95 ft-lb).
17. Remove the jack stands.

Belt Maintenance

Inspecting the Belts

Service Interval: Every 50 hours

Replace the belt if it is worn. The signs of a worn belt include squealing while the belt is rotating; the blades slipping while cutting grass; and frayed edges, burn marks, and cracks on the belt.

Replacing the Mower Belt for Side-Discharge Mower Decks

1. Park the machine on a level surface, disengage the blade-control switch (PTO), and engage the parking brake.
2. Shut off the engine, remove the key, and wait for all moving parts to stop before leaving the operating position.
3. Lower the mower to the 76 mm (3 inch) height of cut.
4. Remove the belt covers ([Figure 97](#)).

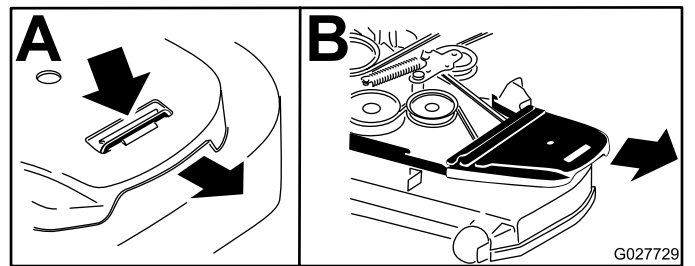

Figure 97

1. Push the tab down.
 2. Remove the belt cover.
-
5. Use a ratchet in the square hole in the idler arm to remove tension on the idler spring ([Figure 98](#)).
 6. Remove the belt from the mower-deck pulleys.
 7. Remove the belt guide on the spring-loaded idler arm ([Figure 98](#)).
 8. Remove the existing belt.
 9. Install the new belt around the mower pulleys and the clutch pulley under the engine ([Figure 98](#)).

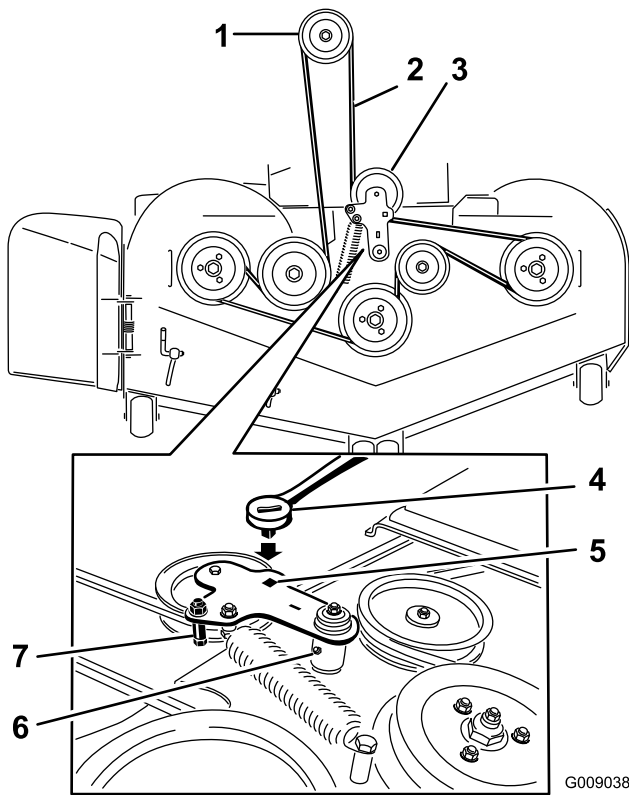

Figure 98

G009038
g009038

- | | |
|-------------------------------|---|
| 1. Clutch pulley | 5. Square hole in the idler arm for the ratchet |
| 2. Mower belt | 6. Idler-grease fitting |
| 3. Spring-loaded idler pulley | 7. Belt guide |
| 4. Ratchet | |

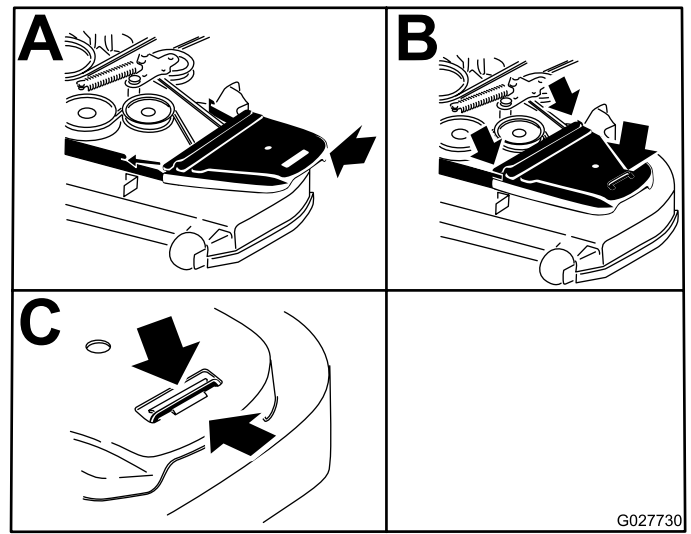

Figure 99

G027730
g027730

1. Position the belt cover.
2. Slide the belt cover under the side catches.
3. Ensure that the tab is under the metal catch.

Replacing the Mower Belt for Rear-Discharge Mower Decks

Replacing the Counter-Rotating Belt

10. Install the belt guide on the idler arm (Figure 98).
11. Using the ratchet in the square hole, install the idler spring (Figure 98).
Note: Make sure that the spring ends are seated in the anchor grooves.
12. Install the belt covers (Figure 99).

1. Park the machine on a level surface, disengage the blade-control switch (PTO), and engage the parking brake.
2. Shut off the engine, remove the key, and wait for all moving parts to stop before leaving the operating position.
3. Lower the mower to the 76 mm (3 inches) height of cut.
4. Lift the floor pan up to gain access to the center pulley.
5. Remove the plastic belt cover (Figure 101).
6. Remove the 3 bolts holding the metal belt cover in place and remove the metal belt cover.

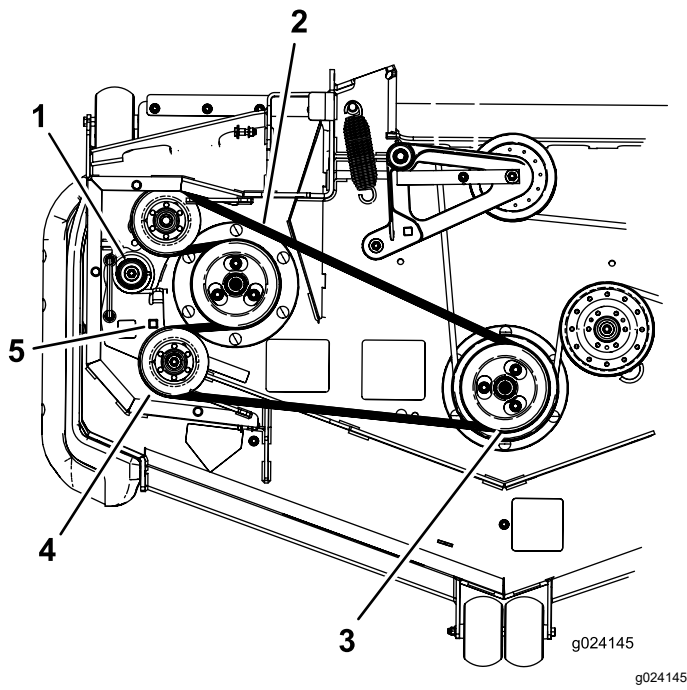

Figure 100

- | | |
|--------------------------|---|
| 1. Idler spring | 4. Idler pulley |
| 2. Counter-rotating belt | 5. Square hole in the idler arm for the ratchet |
| 3. Double pulley | |

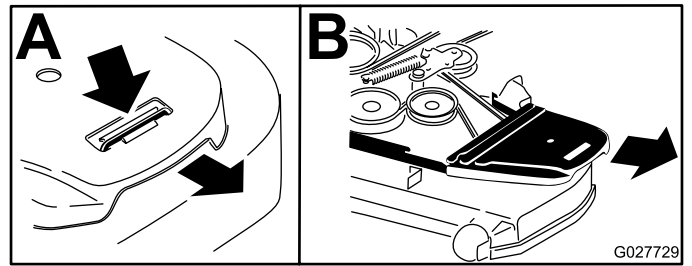

Figure 101

5. Remove the counter-rotating belt; refer to [Replacing the Counter-Rotating Belt \(page 68\)](#).
6. Use a ratchet in the square hole in the idler arm to remove tension on the idler spring ([Figure 102](#)).
7. Remove the belt from the mower-deck pulleys and the clutch pulley.
8. Install the new belt around the mower pulleys and the clutch pulley under the engine ([Figure 102](#)).

7. Use a ratchet in the square hole in the idler arm to remove tension on the idler spring ([Figure 100](#)).
8. Remove the belt from the mower deck pulley ([Figure 100](#)).
9. Remove the belt from the remaining pulleys ([Figure 100](#)).
10. Route the new belt around the mower pulleys.
11. Using the ratchet in the square hole, remove the tension on the spring, and guide the new belt around the idler pulley ([Figure 100](#)).

Replacing the Mower Belt

1. Park the machine on a level surface, disengage the blade-control switch (PTO), and engage the parking brake.
2. Shut off the engine, remove the key, and wait for all moving parts to stop before leaving the operating position.
3. Lower the mower to the 76 mm (3 inches) height of cut.
4. Remove the belt covers ([Figure 101](#)).

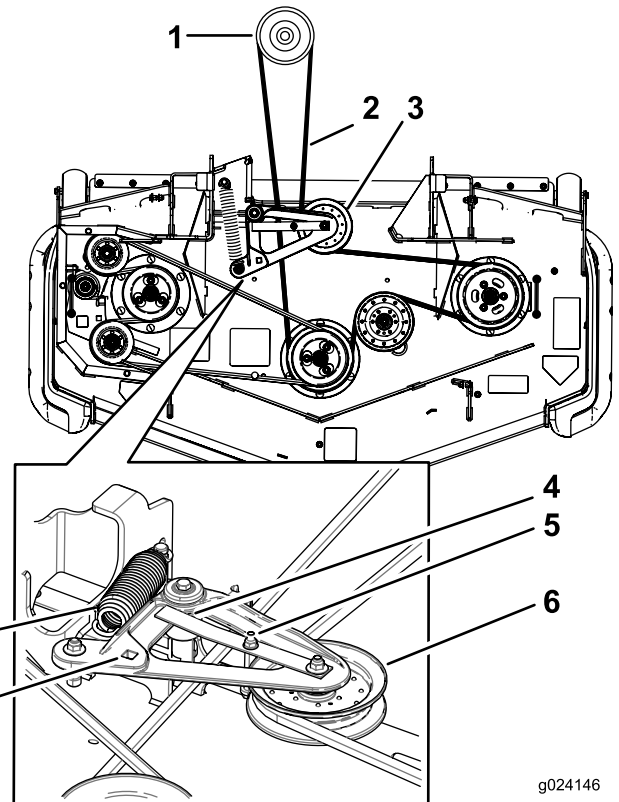

Figure 102

- | | |
|---|---|
| 1. Clutch pulley | 5. Belt guide |
| 2. Mower belt | 6. Spring-loaded idler pulley |
| 3. Spring-loaded idler pulley | 7. Square hole in the idler arm for the ratchet |
| 4. Ensure that the belt-guide tab hits against the pivot hub. | 8. Spring |

9. Rotate and ensure the belt-guide tab hits against the pivot hub (Figure 102).
10. Using the ratchet in the square hole, install the belt around the spring-loaded idler pulley (Figure 102). Seat the spring ends in the anchor grooves.
11. Install the belt covers (Figure 103).

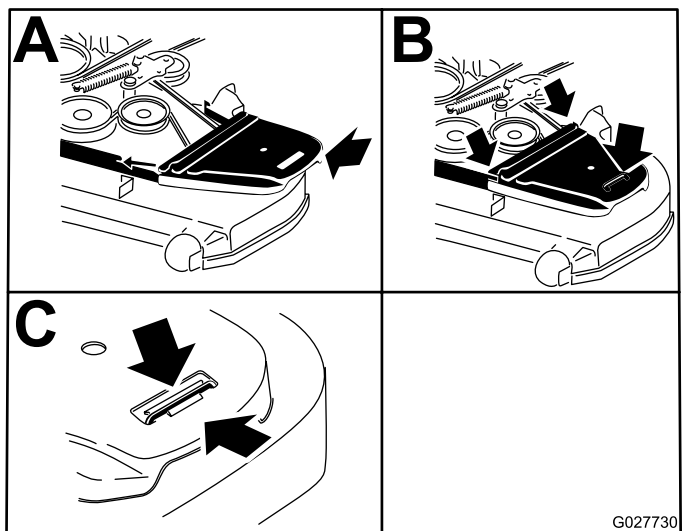

Figure 103

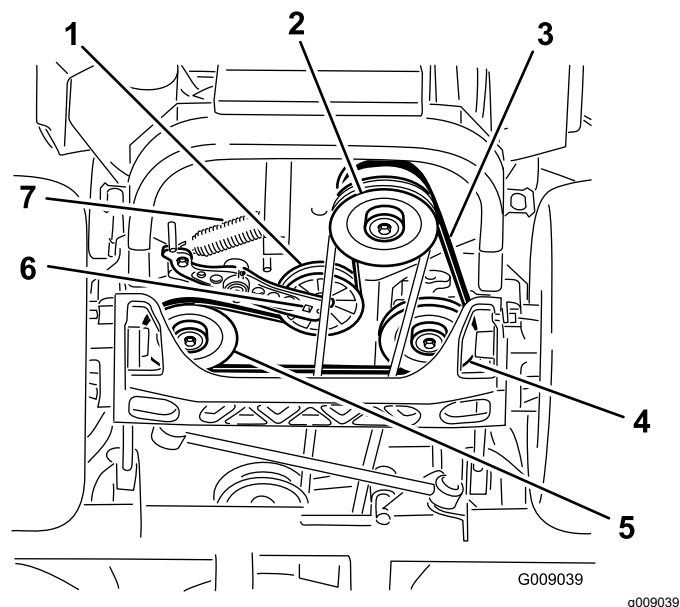

Figure 104

- | | |
|--------------------------------|---------------------------------|
| 1. Idler pulley | 5. Left hydraulic-pump pulley |
| 2. Clutch pulley | 6. Square hole in the idler arm |
| 3. Pump-drive belt | 7. Idler spring |
| 4. Right hydraulic-pump pulley | |

Replacing the Hydraulic Pump-Drive Belt

1. Park the machine on a level surface, disengage the blade-control switch (PTO), and engage the parking brake.
2. Shut off the engine, remove the key, and wait for all moving parts to stop before leaving the operating position.
3. Remove the mower belt; refer to [Replacing the Mower Belt for Side-Discharge Mower Decks \(page 67\)](#) or [Replacing the Mower Belt for Rear-Discharge Mower Decks \(page 68\)](#).
4. Raise the machine and support it with jack stands (Figure 104).

5. Use a ratchet in the square hole in the idler arm to remove the idler spring (Figure 104).
6. Unhook the idler spring from the frame (Figure 104).
7. Remove the belt from the hydraulic-unit-drive pulleys and the engine pulley.
8. Install the new belt around engine pulley and the 2 drive pulleys.
9. Using a ratchet in the square hole in the idler arm, install the idler spring to the frame (Figure 104).
10. Install the mower belt; refer to [Replacing the Mower Belt for Side-Discharge Mower Decks \(page 67\)](#) or [Replacing the Mower Belt for Rear-Discharge Mower Decks \(page 68\)](#).

Controls System Maintenance

Adjusting the Control-Handle Position

There are 2 height positions for the control levers—high and low. Remove the bolts to adjust the height for the operator.

1. Park the machine on a level surface, disengage the blade-control switch (PTO), and engage the parking brake.
2. Shut off the engine, remove the key, and wait for all moving parts to stop before leaving the operating position.
3. Loosen the bolts and flange nuts installed in the levers ([Figure 105](#)).
4. Align the levers in the front-to-rear position by bringing the levers together to the NEUTRAL position, and slide them until they are aligned, then tighten the bolts ([Figure 106](#)).

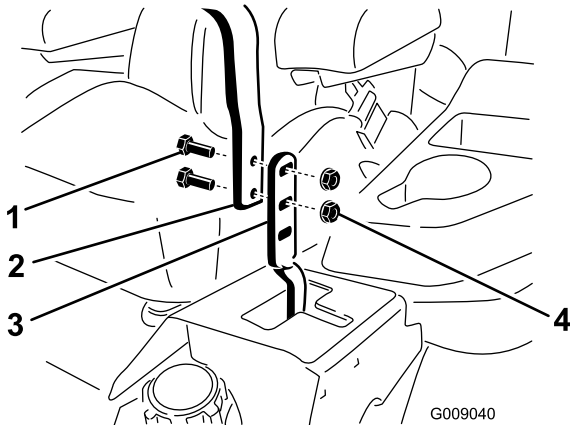

Figure 105

- | | |
|-------------|------------------|
| 1. Bolt (2) | 3. Control lever |
| 2. Handle | 4. Nut (2) |

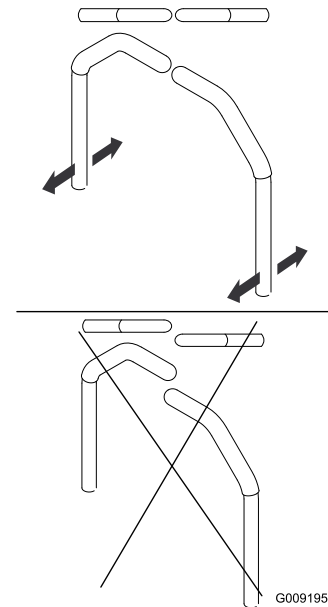

Figure 106

5. If the ends of the levers hit against each other, refer to [Adjusting the Motion-Control Neutral-Lock Pivot](#) ([page 73](#)).
6. Repeat to adjust the control levers.

Adjusting the Motion-Control Linkage

Located on either side of the machine, below the seat, are the pump-control linkages. Rotating the end nut with a 1/2-inch deep socket wrench allows fine tuning adjustments so that the machine does not move in neutral. Any adjustments should be made for neutral positioning only.

⚠ WARNING

The engine must be running and the drive wheels turning so that you can perform the adjustments. Contact with moving parts or hot surfaces may cause personal injury.

Keep your fingers, hands, and clothing clear of rotating components and hot surfaces.

1. Park the machine on a level surface, disengage the blade-control switch (PTO), move the motion-control levers to the NEUTRAL-LOCK position, and engage the parking brake.
2. Shut off the engine, remove the key, and wait for all moving parts to stop before leaving the operating position.
3. Push the deck-lift pedal, remove the height-of-cut pin, and lower the mower deck to the ground

4. Raise the rear of the machine up and support it with jack stands (or equivalent support) just high enough to allow the drive wheels to turn freely.

5. Remove the electrical connection from the seat safety switch, located under the bottom cushion of the seat.

Note: The switch is a part of the seat assembly.

6. **Temporarily** install a jumper wire across the terminals in the connector of the main wire harness.

7. Start the engine, run it at full throttle, and disengage the parking brake.

Note: Before starting the engine, ensure that the parking brake is engaged and that the motion-control levers are out. You do not have to be in the seat.

8. Run the machine at least 5 minutes with the drive levers at full forward speed to bring the hydraulic fluid up to the operating temperature.

Note: The motion-control levers must be in neutral while you are making any adjustments.

9. Bring the motion-control levers into the NEUTRAL position.

10. Adjust the pump-control-rod lengths by rotating the double nuts on the rod in the appropriate direction until the wheels slightly creep in reverse (Figure 107).

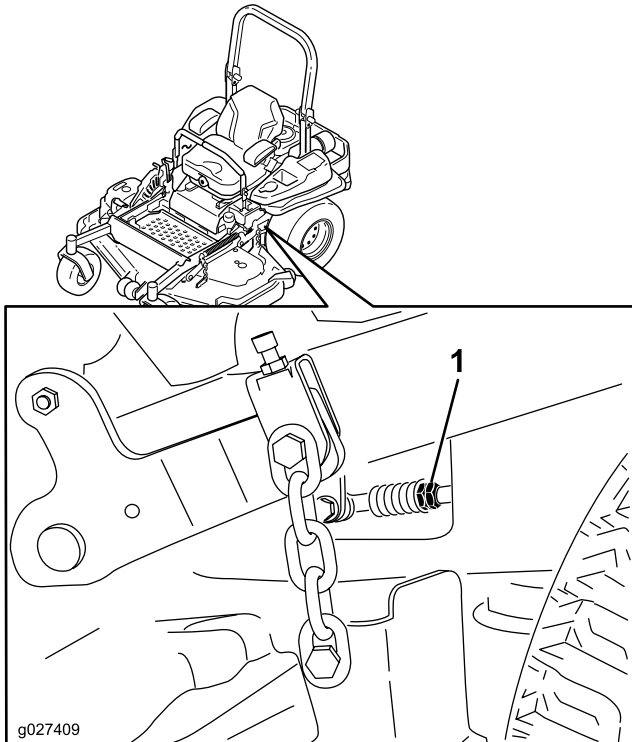

Figure 107

1. Double nuts

11. Move the motion-control levers to the REVERSE position and while applying slight pressure to the lever, allow the reverse-indicator springs to bring the levers back to neutral.

Note: The wheels should stop turning or slightly creep in reverse.

12. Shut off the machine.

13. Remove the jumper wire from the wire harness and plug the connector into the seat switch.

14. Remove the jack stands.

15. Raise the mower deck and install the height-of-cut pin.

16. Check and ensure that the machine does not creep in neutral with the parking brake disengaged.

Adjusting the Motion-Control Damper

You can adjust the top damper-mounting bolt to obtain the desired motion-control lever resistance. Refer to Figure 108 for mounting options.

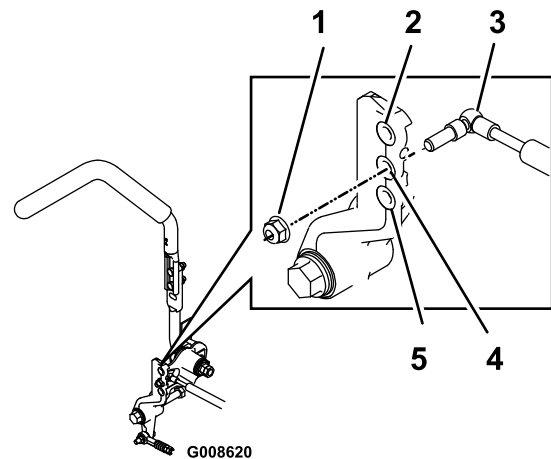

Figure 108

Right Motion Control Shown

1. Torque the locknut to 23 N·m (17 ft-lb). The bolt must protrude past the end of the locknut after torquing.
2. Most resistance (firmest feel)
3. Damper
4. Medium resistance (medium feel)
5. Least resistance (softest feel)

Adjusting the Motion-Control Neutral-Lock Pivot

You can adjust the flanged nut to obtain the desired motion-control lever resistance when moving it to the NEUTRAL-LOCK position. See [Figure 109](#) for adjustment options.

1. Loosen the jam nut.
2. Tighten or loosen the flanged nut to the desired feel.
 - For more resistance, tighten the flanged nut.
 - For less resistance, loosen the flanged nut
3. Tighten the jam nut.

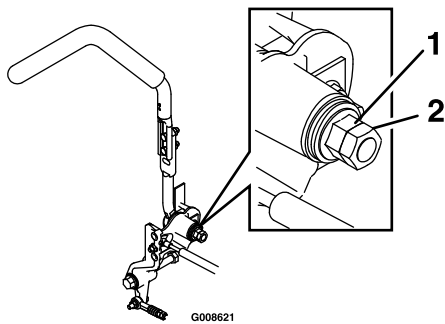

Figure 109

1. Flanged nut

2. Jam nut

Hydraulic System Maintenance

Hydraulic System Safety

- Seek immediate medical attention if fluid is injected into skin. Injected fluid must be surgically removed within a few hours by a doctor.
- Ensure that all hydraulic-fluid hoses and lines are in good condition and all hydraulic connections and fittings are tight before applying pressure to the hydraulic system.
- Keep your body and hands away from pinhole leaks or nozzles that eject high-pressure hydraulic fluid.
- Use cardboard or paper to find hydraulic leaks.
- Safely relieve all pressure in the hydraulic system before performing any work on the hydraulic system.

Hydraulic-Fluid Specifications

Hydraulic-Fluid Type: Toro® HYPR-OIL™ 500 hydraulic fluid or Mobil® 1 15W-50.

Important: Use the specified fluid. Other fluids could damage the hydraulic system.

Each Hydraulic-System Fluid Capacity: 1.5 L (52 fl oz) per side with filter change

Checking the Hydraulic Fluid

Service Interval: Every 50 hours—Check the hydraulic-fluid level.

1. Park the machine on a level surface, disengage the blade-control switch (PTO), and engage the parking brake.
2. Shut off the engine, remove the key, and wait for all moving parts to stop before leaving the operating position.
3. Allow the engine and the hydraulic system to cool for 10 minutes.

Note: The oil level on the dipstick is incorrect when the oil is checked and the machine is hot.

4. Move the seat forward.
5. Clean the area around the dipsticks of hydraulic-system reservoirs ([Figure 110](#)).
6. Remove 1 dipstick from the hydraulic reservoir ([Figure 110](#)).

7. Wipe the dipstick off and thread the dipstick into the reservoir.

8. Remove the dipstick and look at the end ([Figure 110](#)).

Important: Do not overfill the hydraulic units with fluid, as damage may occur. Do not run the machine with fluid below the add mark.

9. If the fluid level is at the add mark, slowly pour only enough fluid into the hydraulic reservoir to raise the level to the full or H line.

10. Install the dipstick.

11. Repeat the procedure for the opposite dipstick.

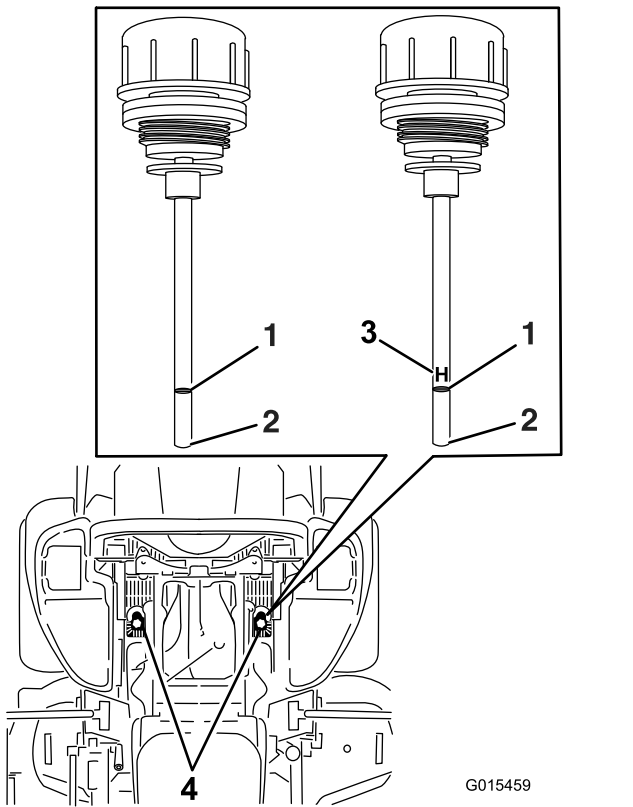

Figure 110

Either dipstick is used in the machine

- | | |
|---------|----------------------------------|
| 1. Full | 3. H —means high level |
| 2. Add | 4. Dipstick locations under seat |

Changing the Hydraulic Fluid and Filters

Service Interval: After the first 250 hours—Change the hydraulic filters and hydraulic fluid.

Every 250 hours—After the initial change—change the hydraulic-system filters and fluid when using Mobil 1 15W50 fluid. (Change it more often under dirty or dusty conditions)

Every 500 hours—After the initial change—change the hydraulic-system filters and fluid when using Toro® HYPR-OIL™ 500 fluid. (Change it more often under dirty or dusty conditions)

To replace the hydraulic fluid, the filters need to be removed. Replace both at the same time; refer to [Hydraulic-Fluid Specifications \(page 73\)](#) for fluid specifications.

1. Park the machine on a level surface, disengage the blade-control switch, and engage the parking brake.
2. Shut off the engine, remove the key, and wait for all moving parts to stop before leaving the operating position.
3. Raise the machine and support it with jack stands ([Figure 111](#)).

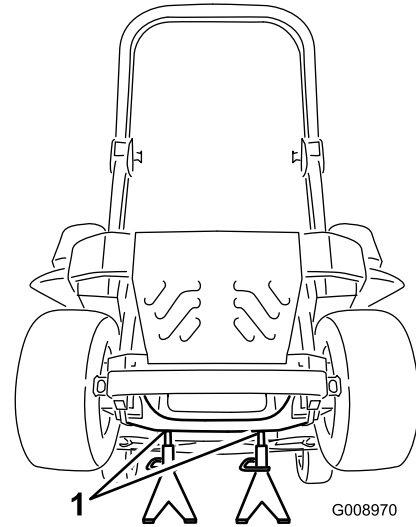

Figure 111

1. Jack stands

4. Remove both the mower belt and the pump-drive belt; refer to [Replacing the Mower Belt \(page 69\)](#) and [Replacing the Hydraulic Pump-Drive Belt \(page 70\)](#).

Note: This prevents fluid from getting on the belts.

5. Place a drain pan under the filter, remove the old filter, and wipe the surface clean (Figure 112).

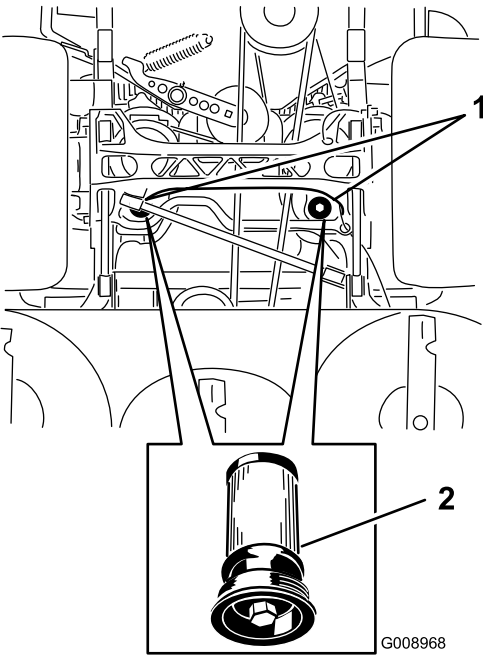

g008968

Figure 112
Bottom view of the machine

1. Filter locations
2. Hydraulic filter

-
6. Apply a thin coat of hydraulic fluid to the rubber gasket on the replacement filter (Figure 112).
 7. Install the replacement hydraulic filter.
 8. Install the pump-drive belt and the mower belt.
 9. Remove the jack stands and lower the machine (Figure 111).
 10. Add fluid to the hydraulic reservoir and check for any leaks.
 11. Clean up any spilled fluid.
 12. Start the engine and let it run for about 2 minutes to purge air from the system.
 13. Shut off the engine and check for leaks.
 14. Check the fluid level while the fluid is cold.
 15. If required, add fluid to the hydraulic reservoir.

Note: Do not overfill.

Mower Deck Maintenance

Blade Safety

- Inspect the blades periodically for wear or damage.
- Use care when checking the blades. Wrap the blades or wear gloves, and use caution when servicing the blades. Only replace or sharpen the blades; never straighten or weld them.
- On multi-bladed machines, take care as rotating one blade can cause other blades to rotate.
- Replace worn or damaged blades and bolts in sets to preserve balance.

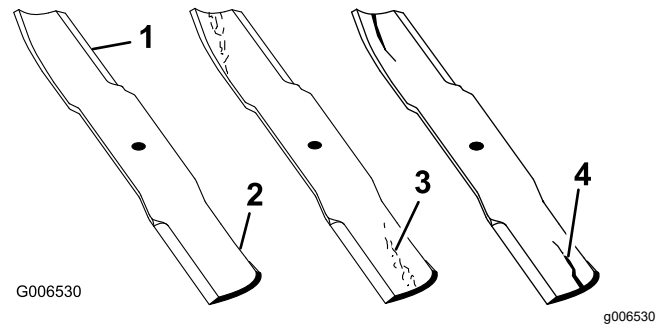

Figure 113

1. Cutting edge
2. Curved area
3. Wear/slot forming
4. Crack

Servicing the Cutting Blades

To ensure a superior quality of cut, keep the blades sharp. For convenient sharpening and replacement, you may want to keep extra blades on hand.

Before Inspecting or Servicing the Blades

1. Park the machine on a level surface, disengage the blade-control switch (PTO), and engage the parking brake.
2. Shut off the engine, remove the key, and disconnect the spark-plug wires from the spark plugs.

Inspecting the Blades

Service Interval: Before each use or daily

1. Inspect the cutting edges ([Figure 113](#)).
2. If the edges are not sharp or have nicks, remove and sharpen the blade; refer to [Sharpening the Blades \(page 78\)](#).
3. Inspect the blades, especially in the curved area.
4. If you notice any cracks, wear, or a slot forming in this area, immediately install a new blade ([Figure 113](#)).

Checking for Bent Blades

Note: The machine must be on a level surface for the following procedure.

1. Raise the mower deck to the highest height-of-cut position.
2. While wearing thickly padded gloves, or other adequate hand protection, slowly rotate the blade into a position that allows you to measure the distance between the cutting edge and the level surface the machine is on (Figure 114).

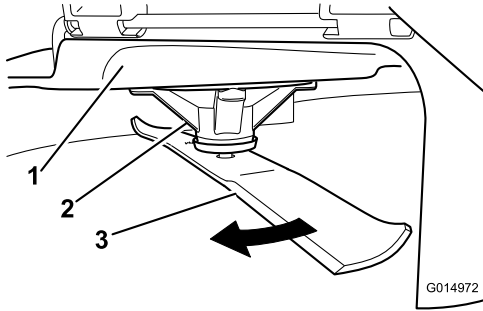

Figure 114

1. Deck
2. Spindle housing
3. Blade

3. Measure from the tip of the blade to the flat surface (Figure 115).

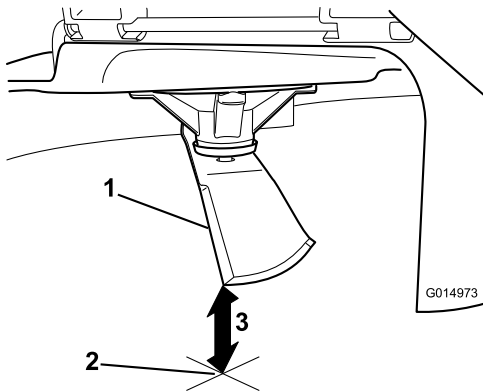

Figure 115

1. Blade (in position for measuring)
2. Level surface
3. Measured distance between blade and the surface (A)

4. Rotate the same blade 180 degrees so that the opposing cutting edge is now in the same position (Figure 116).

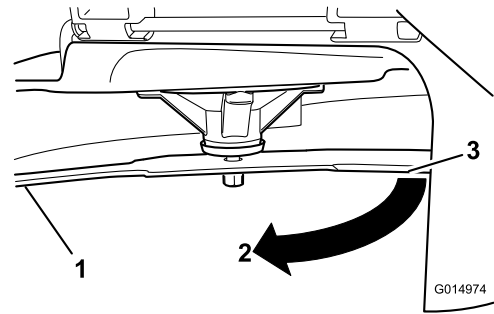

Figure 116

1. Blade (side previously measured)
2. Measurement (position used previously)
3. Opposing side of blade being moved into measurement position

5. Measure from the tip of the blade to the flat surface (Figure 117).

Note: The variance should be no more than 3 mm (1/8 inch).

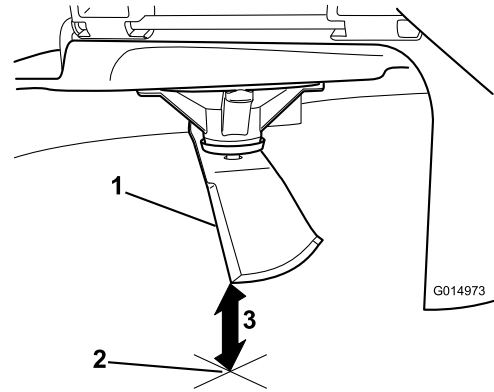

Figure 117

1. Opposite blade edge (in position for measuring)
2. Level surface
3. Second measured distance between blade and surface (B)

- A. If the difference between A and B is greater than 3 mm (1/8 inch), replace the blade with a new blade; refer to [Removing the Blades \(page 78\)](#) and [Installing the Blades \(page 78\)](#).

Note: If a bent blade is replaced with a new blade, and the dimension obtained continues to exceed 3 mm (1/8 inch), the blade spindle could be bent. Contact an Authorized Service Dealer for service.

- B. If the variance is within constraints, move to the next blade.

6. Repeat this procedure on each blade.

Removing the Blades

Replace the blades if they hit a solid object, or if the blade is out of balance or bent.

1. Place a wrench on the flat of the spindle shaft or hold the blade end using a rag or thickly padded glove.
2. Remove the blade bolt, bushing, and blade from the spindle shaft (Figure 118).

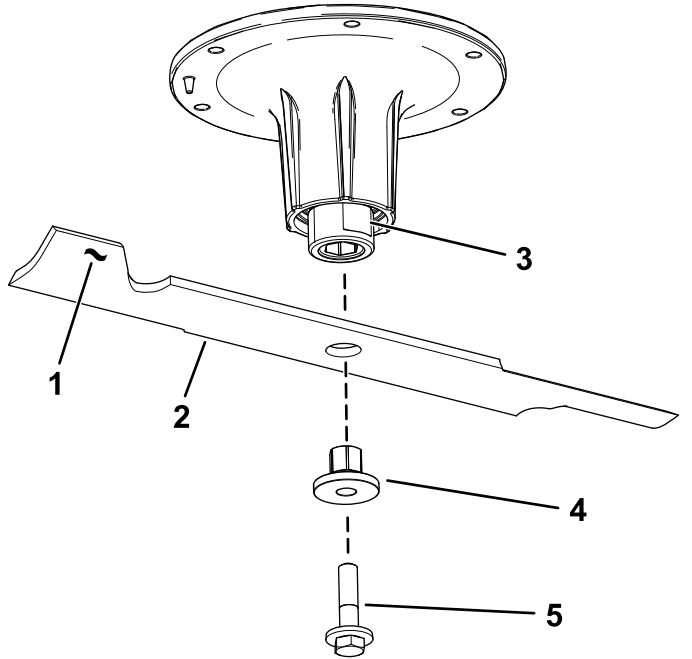

Figure 118

g295816

- | | |
|------------------------------|---------------|
| 1. Sail area of the blade | 4. Bushing |
| 2. Blade | 5. Blade bolt |
| 3. Flat of the spindle shaft | |

Sharpening the Blades

1. Use a file to sharpen the cutting edge at both ends of the blade (Figure 119).

Note: Maintain the original angle.

Note: The blade retains its balance if the same amount of material is removed from both cutting edges.

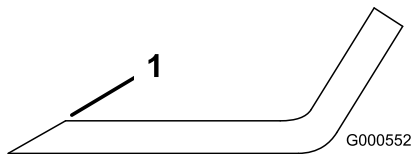

Figure 119

G000552

g000552

1. Sharpen at original angle.
2. Check the balance of the blade by putting it on a blade balancer (Figure 120).

Note: If the blade stays in a horizontal position, the blade is balanced and can be used.

Note: If the blade is not balanced, file some metal off the end of the sail area only (Figure 119).

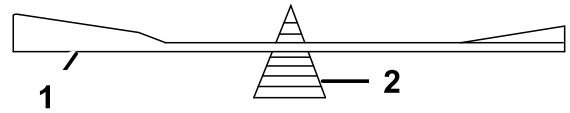

G000553

g000553

Figure 120

- | | |
|----------|-------------|
| 1. Blade | 2. Balancer |
|----------|-------------|

3. Repeat this procedure until the blade is balanced.

Installing the Blades

1. Install the bushing through the blade with the bushing flange on the bottom (grass) side of the blade (Figure 121).

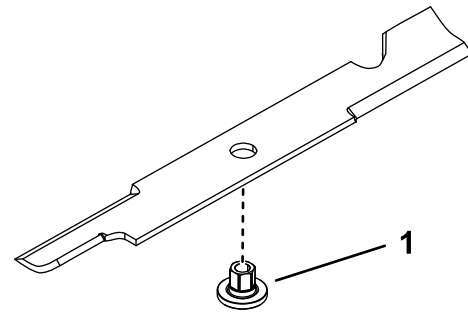

Figure 121

g255205

1. Bushing
2. Install the bushing/blade assembly into the spindle shaft (Figure 122).

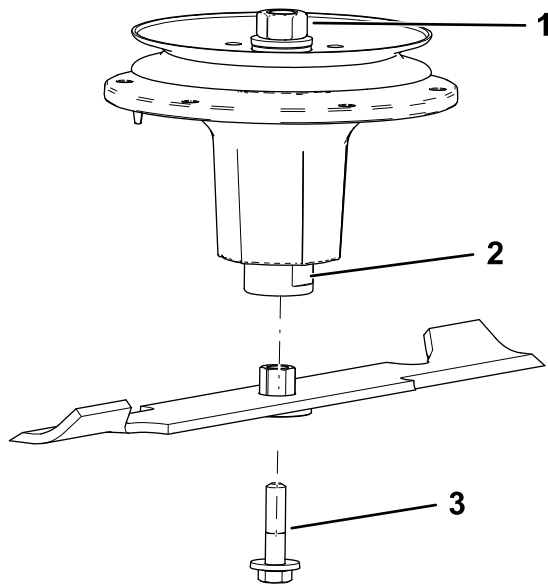

Figure 122

g298850

1. Top spindle nut
2. Flat of the spindle shaft
3. Blade bolt

3. Apply copper-based lubricant or grease to the threads of the blade bolt as needed to prevent seizing. Install the blade bolt finger-tight.
4. Place a wrench on the flat of the spindle shaft and torque the blade bolt to 75 to 81 N·m (55 to 60 ft-lb).

Leveling the Mower Deck

1. Park the machine on a level surface, disengage the blade-control switch (PTO), and engage the parking brake.
2. Shut off the engine, remove the key, and wait for all moving parts to stop before leaving the operating position.
3. Check the tire pressure in the drive tires; refer to [Checking the Tire Pressure \(page 62\)](#).
4. Position the transport lock in the latching position.
5. Push the deck-lift pedal all the way forward and the deck latches at the 14 cm (5-1/2 inch) transport position ([Figure 123](#)).

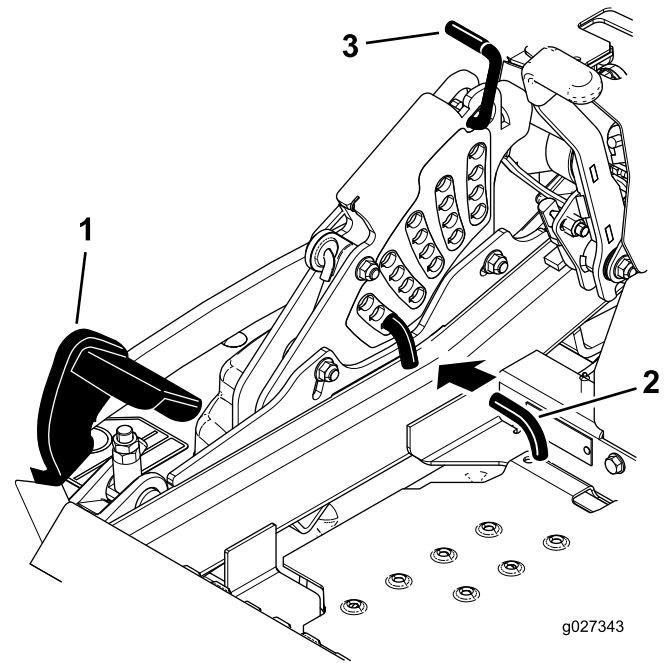

Figure 123

g027343

g027343

1. Deck-lift pedal
2. Height-of-cut pin
3. Transport lock

6. Insert the height-adjustment pin into the 7.6 cm (3 inches) cutting-height location.
7. Release the transport lock and allow the deck to lower to the cutting height.
8. For side-discharge machines, raise the discharge chute.
9. On both sides of the deck, measure from the level surface to the front tip of the blade (Position A) as shown in [Figure 124](#).

Note: The measurement should read 7.6 mm (3 inches)

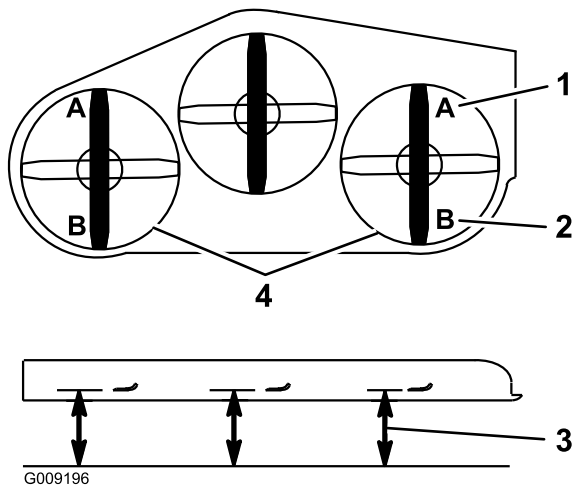

Figure 124

- | | |
|---|--|
| 1. 7.6 cm (3 inch) at position A is correct | 3. Measure here from the blade tip to the hard surface |
| 2. 8.3 cm (3-1/4 inch) at position B is correct | 4. Measure at position A and B on both sides |

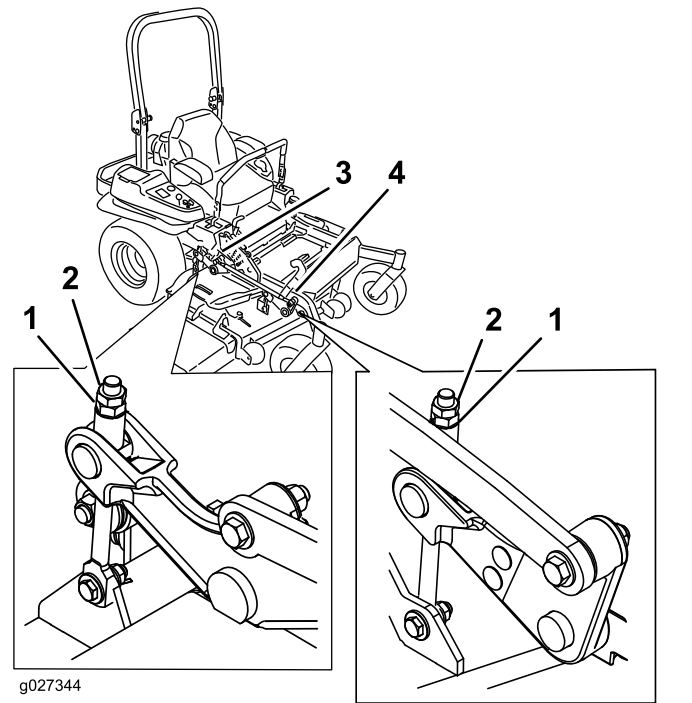

Figure 126

6000 Series Machines

- | | |
|-------------------|--------------------------|
| 1. Adjustment nut | 3. Rear deck adjustment |
| 2. Jam nut | 4. Front deck adjustment |

10. Fine-tune the adjustment nut on the front deck-lift assembly by turning it (Figure 125 or Figure 126).

Note: To increase the height, turn the adjustment nut clockwise; to decrease the height, turn the nut counterclockwise.

Note: If the front deck links do not have enough adjustment to achieve accurate cut height, you can use the single-point adjustment to gain more adjustment.

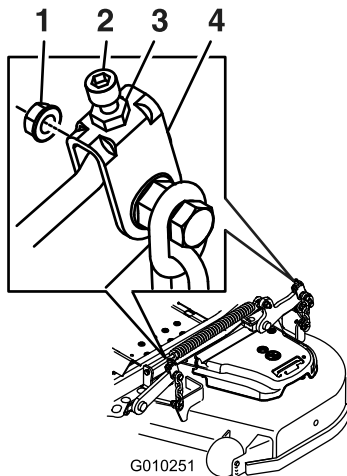

Figure 125

5000 Series Machines

- | | |
|-------------------|--------------------------|
| 1. Adjustment nut | 3. Rear deck adjustment |
| 2. Jam nut | 4. Front deck adjustment |

11. To adjust the single-point system, loosen the 2 bolts at the bottom of the height-of-cut plate (Figure 127).

Note: For rear-discharge machines, the mower deck is attached in the back holes at the factory. Refer to Figure 128. If needed, use the front holes for further adjustment when leveling the mower deck.

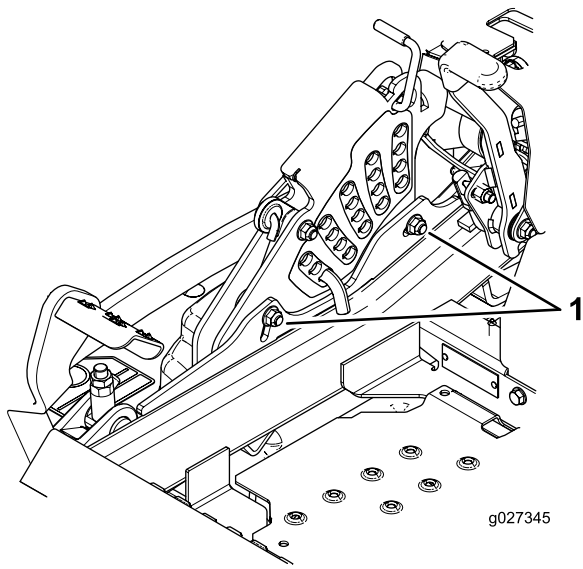

Figure 127

1. Bolts at the bottom of the height-of-cut plate

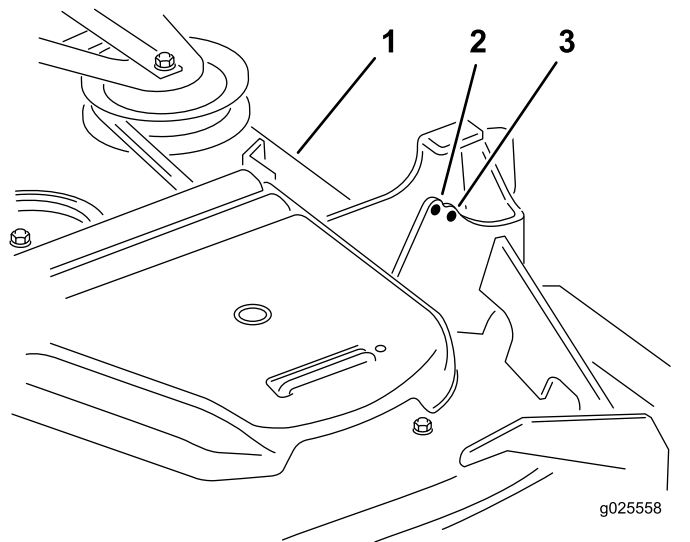

Figure 128

Rear-Discharge Machines Only

1. Mower deck
2. Front hole
3. Back hole

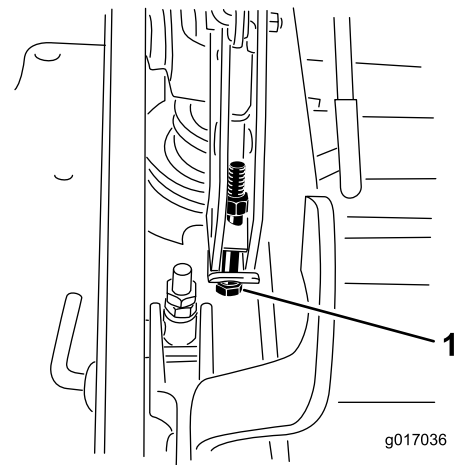

Figure 129

1. Single-point adjustment bolt

13. Tighten the 2 bolts at the bottom of the height-of-cut plate (Figure 127).

Note: In most conditions, the back blade tip should be adjusted 6.4 mm (1/4 inch) higher than the front.

14. Torque the 2 bolts to 37 to 45 N·m (27 to 33 ft-lb).
15. On both sides of the deck, measure from the level surface to the back tip of the blade (position B) as shown in Figure 124.

Note: The measurement should read 8.3 cm (3-1/4 inches)

16. Fine tune the screw adjuster by turning it to get 8.3 mm (3-1/4 inches) height (Figure 126).

To increase the height, turn the adjustment nut clockwise; to decrease, turn counterclockwise.

17. Measure until all 4 sides are the correct height.
18. Tighten all of the nuts on the deck-lift-arm assemblies.
19. For side-discharge machines, lower the discharge chute.

12. If the deck is too low, tighten the single-point-adjustment bolt by rotating it clockwise. If the deck is too high, loosen the single-point-adjustment bolt by rotating it counterclockwise (Figure 129).

Note: Loosen or tighten the single-point adjustment bolt enough to move the height-of-cut plate mounting bolts at least 1/3 the length of the available travel in their slots. This regains some up and down adjustment on each of the 4 deck links.

Removing the Mower Deck

Lock out the spring-loaded deck arms before servicing or removing the mower deck.

⚠ WARNING

Deck-lift arm assemblies have stored energy. Removing the deck with out releasing the stored energy can cause serious injury or death.

Do not attempt to disassemble the deck from the front frame without locking out the stored energy.

1. Park the machine on a level surface, disengage the blade-control switch (PTO), and engage the parking brake.
2. Shut off the engine, remove the key, and wait for all moving parts to stop before leaving the operating position.
3. Place the height adjustment pin in the 7.6 cm (3 inch) cutting-height location.

Note: This locks the deck-lift arms in the lowest position when the deck is removed and the stored energy in the deck spring is released.

4. Remove the belt covers.
5. Lift up the floor pan and insert a ratchet into the square hole in the deck idler (Figure 130 or Figure 131).
6. Rotate the deck idler clockwise, lift up on the belt-guide tab (rear-discharge machines only), and remove the mower belt (Figure 130 or Figure 131).

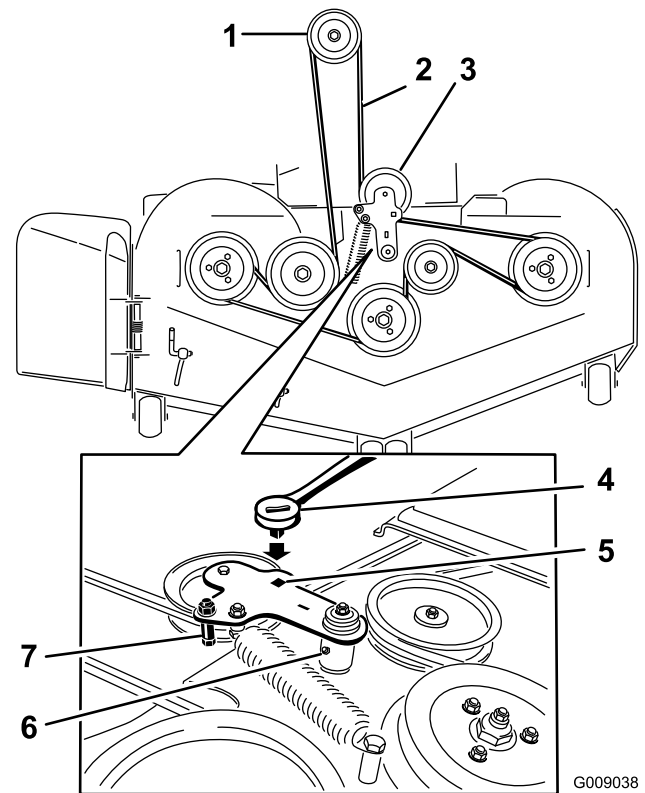

G009038
g009038

Figure 130
Side-Discharge Machines

- | | |
|-------------------------------|---|
| 1. Clutch pulley | 5. Square hole in the idler arm for the ratchet |
| 2. Mower belt | 6. Idler grease fitting |
| 3. Spring-loaded idler pulley | 7. Belt guide |
| 4. Ratchet | |

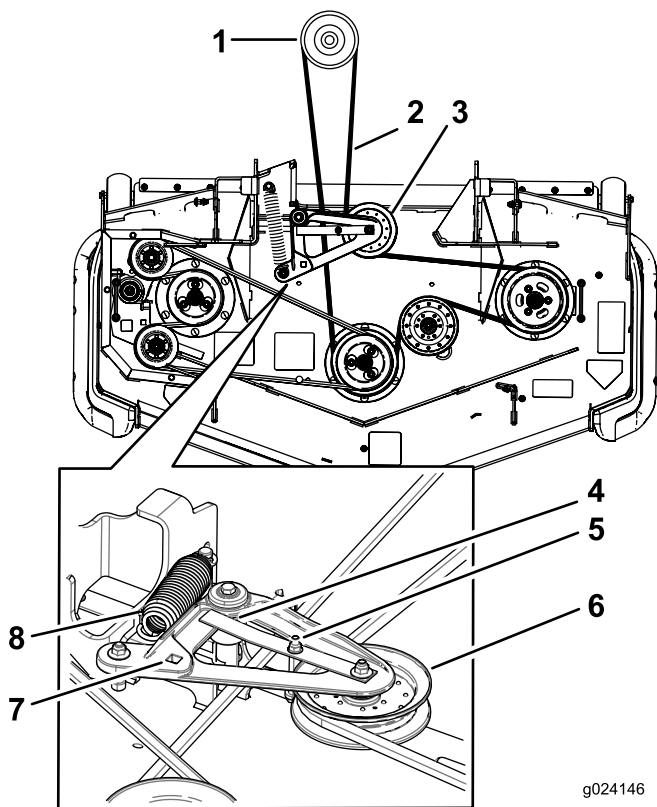

Figure 131
Rear-Discharge Machines

- | | |
|---|---|
| 1. Clutch pulley | 5. Belt guide |
| 2. Mower belt | 6. Spring-loaded idler pulley |
| 3. Spring-loaded idler pulley | 7. Square hole in the idler arm for the ratchet |
| 4. Ensure that the belt-guide tab hits against the pivot hub. | 8. Spring |

-
7. Remove and retain the hardware on both sides of the deck as shown in [Figure 132](#).

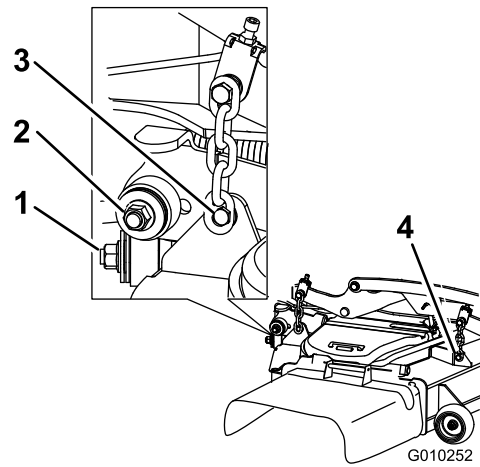

Figure 132

1. Right stabilizer
2. Deck strut (right side shown)
3. Remove the shoulder bolt and nut.
4. Remove the shoulder bolt and nut.

-
8. Raise the deck struts and secure them in the raised position.
 9. Slide the deck out to the right side of the machine.

Replacing the Grass Deflector

Side-Discharge Machines Only

position and ensure that it rotates into the full down position.

⚠ WARNING

An uncovered discharge opening could allow the machine to throw objects toward you or bystanders, resulting in serious injury. Also, contact with the blade could occur.

Never operate the machine unless you install a mulch plate, discharge deflector, or grass collection system.

1. Remove the locknut, bolt, spring, and spacer holding the deflector to the pivot brackets (Figure 133).
2. Remove the damaged or worn grass deflector (Figure 133).

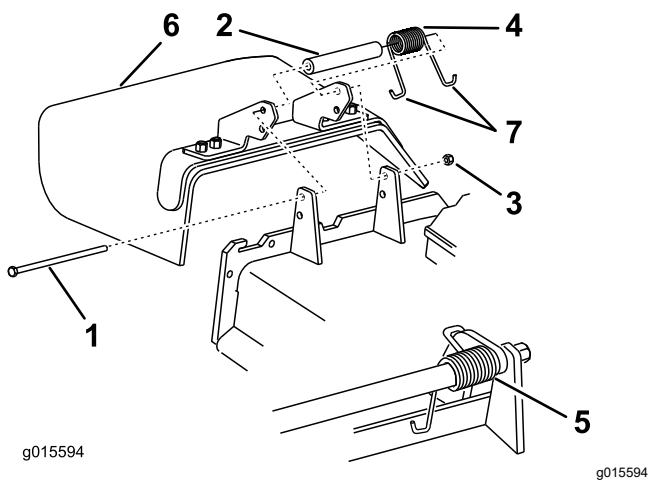

Figure 133

- | | |
|------------|-------------------------|
| 1. Bolt | 5. Spring installed |
| 2. Spacer | 6. Grass deflector |
| 3. Locknut | 7. J-hook end of spring |
| 4. Spring | |

3. Place the spacer and the spring onto grass deflector.
4. Place 1 J-hook end of the spring behind the deck edge.

Note: Make sure that 1 J-hook end of the spring is installed behind the deck edge before installing the bolt as shown in Figure 133.

5. Install the bolt and the nut.
6. Place 1 J-hook end of the spring around the grass deflector (Figure 133).

Important: The grass deflector must be able to rotate. Lift the deflector up to the full open

Cleaning

Cleaning under the Mower Deck

Service Interval: After each use

1. Park the machine on a level surface, disengage the blade-control switch (PTO), and engage the parking brake.
2. Shut off the engine, remove the key, and wait for all moving parts to stop before leaving the operating position.
3. Raise the mower deck to the TRANSPORT position.

Disposing of Waste

Engine oil, batteries, hydraulic fluid, and engine coolant are pollutants to the environment. Dispose of these according to your state and local regulations.

Storage

Storage Safety

- Shut off the engine, remove the key, and wait for all moving parts to stop before you leave the operator's position. Allow the machine to cool before adjusting, servicing, cleaning, or storing it.
- Do not store the machine or fuel near flames or drain the fuel indoors or inside an enclosed trailer.
- Do not store the machine or fuel container where there is an open flame, spark, or pilot light, such as on a water heater or on other appliances.

Cleaning and Storage

1. Disengage the blade-control switch (PTO), and engage the parking brake.
2. Shut off the engine, remove the key, and wait for all moving parts to stop before leaving the operating position.
3. Remove grass clippings, dirt, and grime from the external parts of the entire machine, especially the engine and hydraulic system. Clean dirt and chaff from the outside of the engine cylinder head fins and blower housing.

Important: You can wash the machine with mild detergent and water. Do not pressure wash the machine. Avoid excessive use of water, especially near the control panel, engine, hydraulic pumps, and motors.

4. Check the parking brake operation; refer to [Adjusting the Parking Brake \(page 66\)](#).
5. Service the air cleaner; refer to [Servicing the Air Cleaner \(page 50\)](#).
6. Grease the machine; refer to [Lubrication \(page 41\)](#).
7. Change the crankcase oil; refer to [Servicing the Engine Oil \(page 51\)](#).
8. Check the tire pressure; refer to [Checking the Tire Pressure \(page 62\)](#).
9. Change the hydraulic filters; refer to [Changing the Hydraulic Fluid and Filters \(page 74\)](#).
10. Charge the battery; refer to [Charging the Battery \(page 57\)](#).
11. Scrape any heavy buildup of grass and dirt from the underside of the mower, then wash the mower with a garden hose.

Note: Run the machine with the blade-control switch (PTO) engaged and the engine at high idle for 2 to 5 minutes after washing.

12. Check the condition of the blades; refer to [Servicing the Cutting Blades \(page 76\)](#).
 13. Prepare the machine for storage when non-use occurs over 30 days. Prepare the machine for storage as follows:
 - A. Add a petroleum-based stabilizer/conditioner to fuel in the tank. Follow mixing instructions from the stabilizer manufacturer. Do not use an alcohol-based stabilizer (ethanol or methanol).
- Note:** A fuel stabilizer/conditioner is most effective when mixed with fresh fuel and used at all times.
- B. Run the engine to distribute conditioned fuel through the fuel system for 5 minutes.
 - C. Shut off the engine, allow it to cool, and drain the fuel tank.
 - D. Start the engine and run it until it stops.
 - E. Dispose of fuel properly. Recycle the fuel according to local codes.

Important: Do not store fuel containing stabilizer/conditioner longer than the duration recommended by the fuel-stabilizer manufacturer.

14. Remove and check the condition of the spark plug(s); refer to [Servicing the Spark Plug \(page 53\)](#). With the spark plug(s) removed from the engine, pour 30 ml (2 tablespoons) of engine oil into the spark plug hole. Use the starter to crank the engine and distribute the oil inside the cylinder. Install the spark plug(s). Do not install the wire on the spark plug(s).
15. Check and tighten all bolts, nuts, and screws. Repair or replace any part that is damaged.
16. Paint all scratched or bare metal surfaces. Paint is available from your Authorized Service Dealer.
17. Store the machine in a clean, dry garage or storage area. Remove the key from the switch and keep it out of reach of children or other unauthorized users. Cover the machine to protect it and keep it clean.

Troubleshooting

Problem	Possible Cause	Corrective Action
The malfunction-indicator light (MIL) comes on.	<ol style="list-style-type: none"> 1. The engine is too hot. 2. There is old fuel in the fuel tank. 3. The fuel-shutoff valve is not open completely. 4. The air cleaner is dirty. 5. The battery is not charged. 6. Incorrect fuel filters are being used or the fuel filters are dirty. 7. The connections to the sensors electronic-control unit (ECU) and fuel injectors are not secured properly. 8. There is low voltage from the battery. 9. A fuse is blown. 	<ol style="list-style-type: none"> 1. Shut off the engine and let it cool. 2. Use new fuel. 3. Open the fuel-shutoff valve. 4. Make sure that the air cleaner and precleaner are clean. Replace if necessary. 5. Charge or replace the battery. 6. Contact an Authorized Service Dealer. 7. Contact an Authorized Service Dealer. 8. Ensure that you are using a good 12 V battery and that it is fully charged. 9. Check and replace any blown fuses.
The starter does not crank.	<ol style="list-style-type: none"> 1. The blade-control switch is engaged. 2. The parking brake is disengaged. 3. The motion-control levers are not in the NEUTRAL-LOCK position. 4. You are not sitting in the operator's seat. 5. The battery is dead. 6. The electrical connections are corroded or loose. 7. A fuse is blown. 8. A relay or switch is damaged. 	<ol style="list-style-type: none"> 1. Disengage the blade-control switch. 2. Engage the parking brake. 3. Move the motion-control levers outward to the NEUTRAL-LOCK position. 4. Sit on the operator's seat. 5. Charge the battery. 6. Check the electrical connections for good contact. 7. Replace the fuse. 8. Contact an Authorized Service Dealer.
The engine does not start, starts hard, or fails to keep running.	<ol style="list-style-type: none"> 1. The fuel tank is empty. 2. The fuel-shutoff valve is closed. 3. The oil level in the crankcase is low. 4. The throttle is not in the correct position. 5. There is dirt in the fuel filter. 6. There is dirt, water, or stale fuel in the fuel system. 7. The air cleaner is dirty. 8. The seat switch is not functioning properly. 9. The electrical connections are corroded, loose, or damaged. 10. The relay or switch is worn or damaged. 11. The spark plug is fouled or improperly gapped. 12. The spark-plug wire is not connected. 	<ol style="list-style-type: none"> 1. Fill the fuel tank. 2. Open the fuel-shutoff valve. 3. Add oil to the crankcase. 4. Be sure that the throttle control is midway between the SLOW and FAST positions. 5. Replace the fuel filter. 6. Contact an Authorized Service Dealer. 7. Clean or replace the air-cleaner element. 8. Check the seat-switch indicator. Replace the seat if necessary. 9. Check the electrical connections for good contact. Clean the connector terminals thoroughly with electrical-contact cleaner, apply dielectric grease, and make the appropriate connections. 10. Contact an Authorized Service Dealer. 11. Adjust or replace the spark plug. 12. Check the spark-plug wire connection.

Problem	Possible Cause	Corrective Action
The engine loses power.	<ol style="list-style-type: none"> 1. The engine load is excessive. 2. The air cleaner is dirty. 3. The oil level in the crankcase is low. 4. The cooling fins and the air passages above the engine are plugged. 5. The vent hole in the fuel cap is plugged. 6. There is dirt in the fuel filter. 7. There is dirt, water, or stale fuel in the fuel system. 	<ol style="list-style-type: none"> 1. Reduce the ground speed. 2. Clean the air-cleaner element. 3. Add oil to the crankcase. 4. Remove the obstruction from the cooling fins and the air passages. 5. Clean or replace the fuel cap. 6. Replace the fuel filter. 7. Contact an Authorized Service Dealer.
The engine overheats.	<ol style="list-style-type: none"> 1. The engine load is excessive. 2. The oil level in the crankcase is low. 3. The cooling fins and air passages under the engine-blower housing are plugged. 4. The air cleaner is dirty. 5. Dirt, water, or stale fuel is in the fuel system. 	<ol style="list-style-type: none"> 1. Reduce the ground speed. 2. Add oil to the crankcase. 3. Remove the obstruction from the cooling fins and air passages. 4. Clean or replace the air-cleaner element. 5. Contact an Authorized Service Dealer
The machine pulls to the left or right (with the motion-control levers fully forward).	<ol style="list-style-type: none"> 1. The tracking needs adjustment 2. The tire pressure in the drive tires is not correct. 	<ol style="list-style-type: none"> 1. Adjust the tracking. 2. Adjust the tire pressure in the drive tires.
The machine does not drive.	<ol style="list-style-type: none"> 1. The bypass valves are not closed tight. 2. The pump belt is worn, loose, or broken. 3. The pump belt is off a pulley. 4. The idler spring is broken or missing. 5. The hydraulic fluid level is low or too hot. 	<ol style="list-style-type: none"> 1. Tighten the bypass valves. 2. Change the belt. 3. Change the belt. 4. Replace the spring. 5. Add hydraulic fluid to the reservoirs or let it cool down.
The machine vibrates abnormally.	<ol style="list-style-type: none"> 1. The cutting blade(s) is/are bent or unbalanced. 2. The blade mounting bolt is loose. 3. The engine mounting bolts are loose. 4. The engine pulley, idler pulley, or blade pulley is loose. 5. The engine pulley is damaged. 6. The blade spindle is bent. 7. The motor mount is loose or worn. 	<ol style="list-style-type: none"> 1. Install new cutting blade(s). 2. Tighten the blade mounting bolt. 3. Tighten the engine mounting bolts. 4. Tighten the appropriate pulley. 5. Contact an Authorized Service Dealer. 6. Contact an Authorized Service Dealer. 7. Contact an Authorized Service Dealer.
The cutting height is uneven.	<ol style="list-style-type: none"> 1. The blade(s) is not sharp. 2. A cutting blade(s) is/are bent. 3. The mower is not level. 4. An anti-scalp roller (if applicable) is not set correctly. 5. The underside of the mower deck is dirty. 6. The tire pressure is incorrect. 7. A blade spindle is bent. 	<ol style="list-style-type: none"> 1. Sharpen the blade(s). 2. Install a new cutting blade(s). 3. Level the mower from side-to-side and front-to-rear. 4. Adjust the anti-scalp wheel height. 5. Clean the underside of the mower deck. 6. Adjust the tire pressure. 7. Contact an Authorized Service Dealer.

Problem	Possible Cause	Corrective Action
The blades do not rotate.	<ol style="list-style-type: none"> 1. The mower deck belt is damaged, worn, loose, or broken. 2. The mower deck belt is off the pulley. 3. The pump drive belt is worn, loose, or broken. 4. The idler spring is broken or missing. 	<ol style="list-style-type: none"> 1. Install a new deck belt. 2. Install the mower belt on the deck pulley and check the idler pulley, idler arm, and spring for correct position and function. 3. Check the belt tension or install a new belt. 4. Replace the spring.
The clutch does not engage.	<ol style="list-style-type: none"> 1. The fuse is blown. 2. There is low voltage supply at the clutch. 3. The coil is damaged. 4. There is inadequate current supply. 5. The rotor/armature air gap is too large. 	<ol style="list-style-type: none"> 1. Replace the fuse. Check the coil resistance, battery charge, charging system, and wiring connections, and replace components if necessary. 2. Check the coil resistance, battery charge, charging system, and wiring connections and replace parts if necessary. 3. Replace the clutch. 4. Repair or replace the clutch lead wire or electrical system. Clean the connector contacts. 5. Remove the shim or replace the clutch.

Schematics

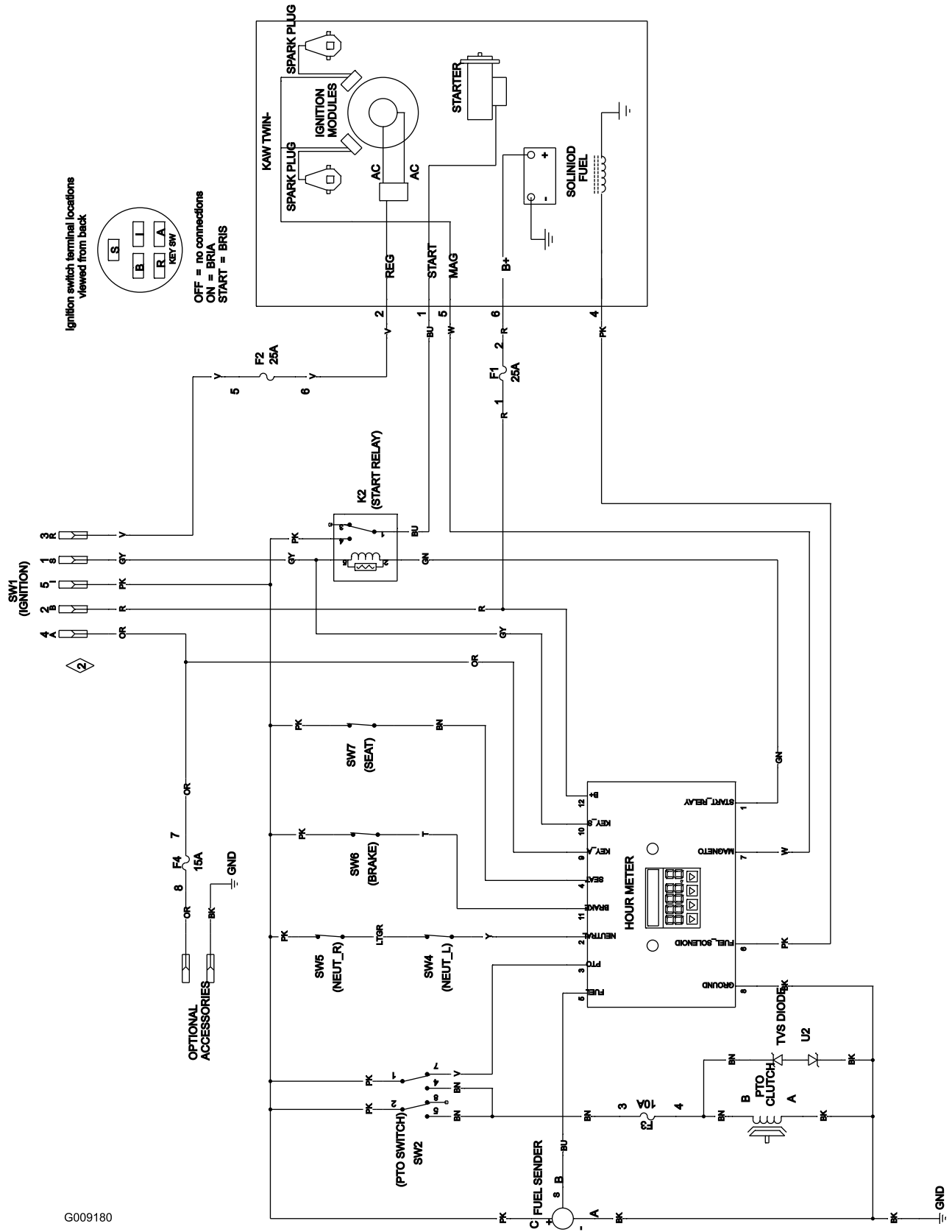

G009180

g009180

Electrical Schematic—Kawasaki Engines (Rev. A)

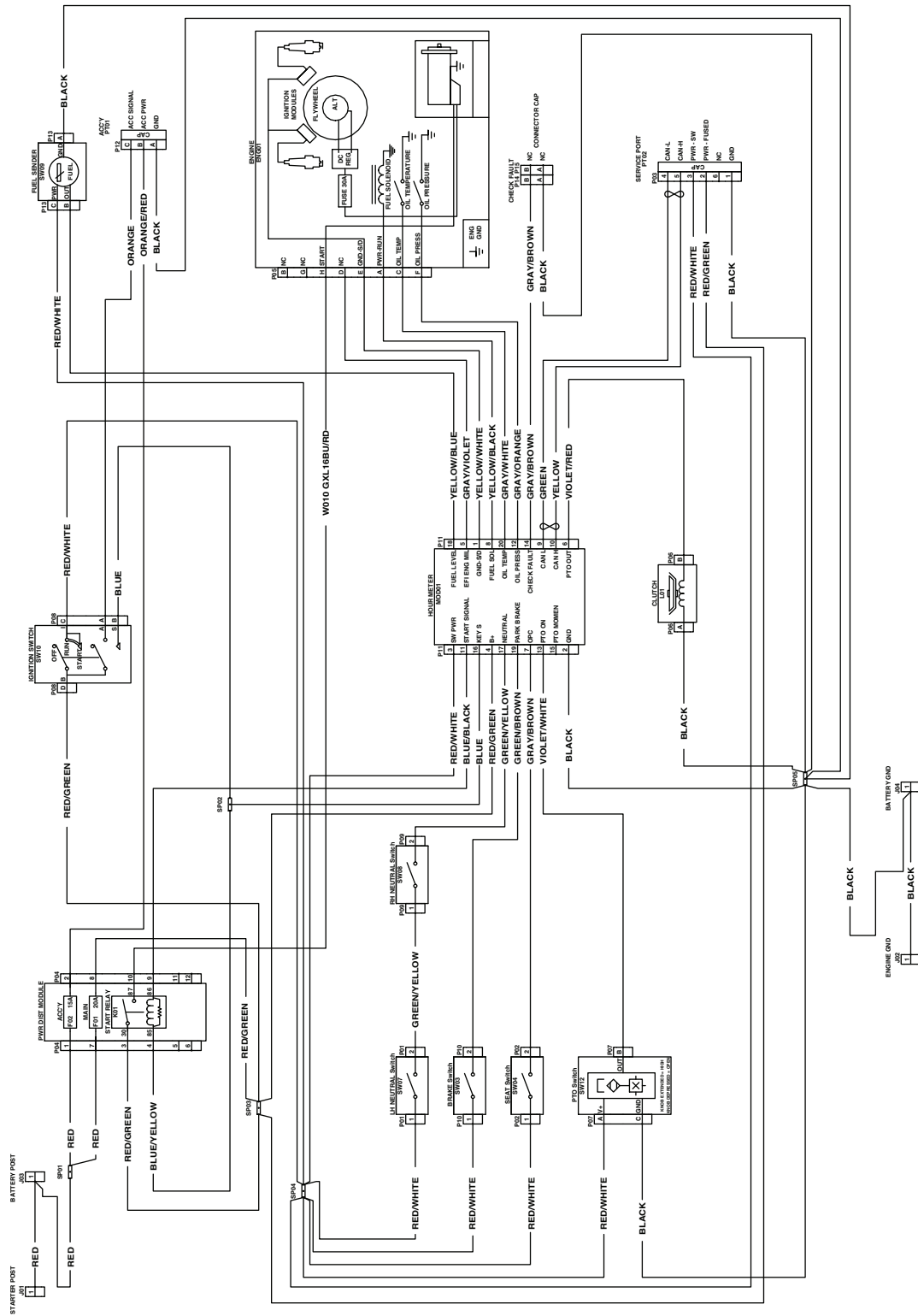

Electrical Schematic—Kohler Engines (Rev. A)

g224051

California Proposition 65 Warning Information

What is this warning?

You may see a product for sale that has a warning label like the following:



WARNING: Cancer and Reproductive Harm—www.p65Warnings.ca.gov.

What is Prop 65?

Prop 65 applies to any company operating in California, selling products in California, or manufacturing products that may be sold in or brought into California. It mandates that the Governor of California maintain and publish a list of chemicals known to cause cancer, birth defects, and/or other reproductive harm. The list, which is updated annually, includes hundreds of chemicals found in many everyday items. The purpose of Prop 65 is to inform the public about exposure to these chemicals.

Prop 65 does not ban the sale of products containing these chemicals but instead requires warnings on any product, product packaging, or literature with the product. Moreover, a Prop 65 warning does not mean that a product is in violation of any product safety standards or requirements. In fact, the California government has clarified that a Prop 65 warning "is not the same as a regulatory decision that a product is 'safe' or 'unsafe.'" Many of these chemicals have been used in everyday products for years without documented harm. For more information, go to <https://oag.ca.gov/prop65/faqs-view-all>.

A Prop 65 warning means that a company has either (1) evaluated the exposure and has concluded that it exceeds the "no significant risk level"; or (2) has chosen to provide a warning based on its understanding about the presence of a listed chemical without attempting to evaluate the exposure.

Does this law apply everywhere?

Prop 65 warnings are required under California law only. These warnings are seen throughout California in a wide range of settings, including but not limited to restaurants, grocery stores, hotels, schools, and hospitals, and on a wide variety of products. Additionally, some online and mail order retailers provide Prop 65 warnings on their websites or in catalogs.

How do the California warnings compare to federal limits?

Prop 65 standards are often more stringent than federal and international standards. There are various substances that require a Prop 65 warning at levels that are far lower than federal action limits. For example, the Prop 65 standard for warnings for lead is 0.5 µg/day, which is well below the federal and international standards.

Why don't all similar products carry the warning?

- Products sold in California require Prop 65 labelling while similar products sold elsewhere do not.
- A company involved in a Prop 65 lawsuit reaching a settlement may be required to use Prop 65 warnings for its products, but other companies making similar products may have no such requirement.
- The enforcement of Prop 65 is inconsistent.
- Companies may elect not to provide warnings because they conclude that they are not required to do so under Prop 65; a lack of warnings for a product does not mean that the product is free of listed chemicals at similar levels.

Why does Toro include this warning?

Toro has chosen to provide consumers with as much information as possible so that they can make informed decisions about the products they buy and use. Toro provides warnings in certain cases based on its knowledge of the presence of one or more listed chemicals without evaluating the level of exposure, as not all the listed chemicals provide exposure limit requirements. While the exposure from Toro products may be negligible or well within the "no significant risk" range, out of an abundance of caution, Toro has elected to provide the Prop 65 warnings. Moreover, if Toro does not provide these warnings, it could be sued by the State of California or by private parties seeking to enforce Prop 65 and subject to substantial penalties.