

Parts Catalog

50in and 54in Bagger Zero-Turn-Radius Riding Mower

Model No. 79392—Serial No. 416800000 and Up



Ordering Replacement Parts

To order replacement parts, please supply the part number, the quantity, and the description of each part desired.

Understanding Reference Numbers

Each identified part in an illustration has a reference number. The reference number for a part also appears in the parts list, along with other information about the part.

This catalog uses two special reference number formats, one to indicate parts in a service assembly and another to indicate the quantity of a given part in an illustration.

Service Assembly Reference Numbers

Parts in service assemblies have reference numbers in the form a:b. The a represents the reference number of the entire service assembly and the b represents a sequential number unique to each part within the service assembly.

For example, a wheel assembly might be identified by reference number 6, the tire by 6:1, the valve by 6:2, and the wheel by 6:3. When you order the assembly identified by reference number 6, you receive all parts identified by reference numbers 6:1, 6:2, and 6:3. However, you may also order any part individually. Reference numbers of this type appear in illustration and in parts lists.

Reference Numbers Indicating Quantity

In an illustration, if a reference number indicates more than one part, the reference number has the form nX y. The n represents the quantity of the part, the X is the multiplication symbol, and the y represents the reference number.

For example, in an illustration, the reference number 2X 37 means that two of the parts identified by reference number 37 are indicated.

Contents

Frame and Bag Assembly.....	4
Bagger Top Assembly No. 131-8654	6
50 Inch Chute Mounting Assembly	8
50 Inch Chute Assembly No. 119-8864	10

Frame and Bag Assembly

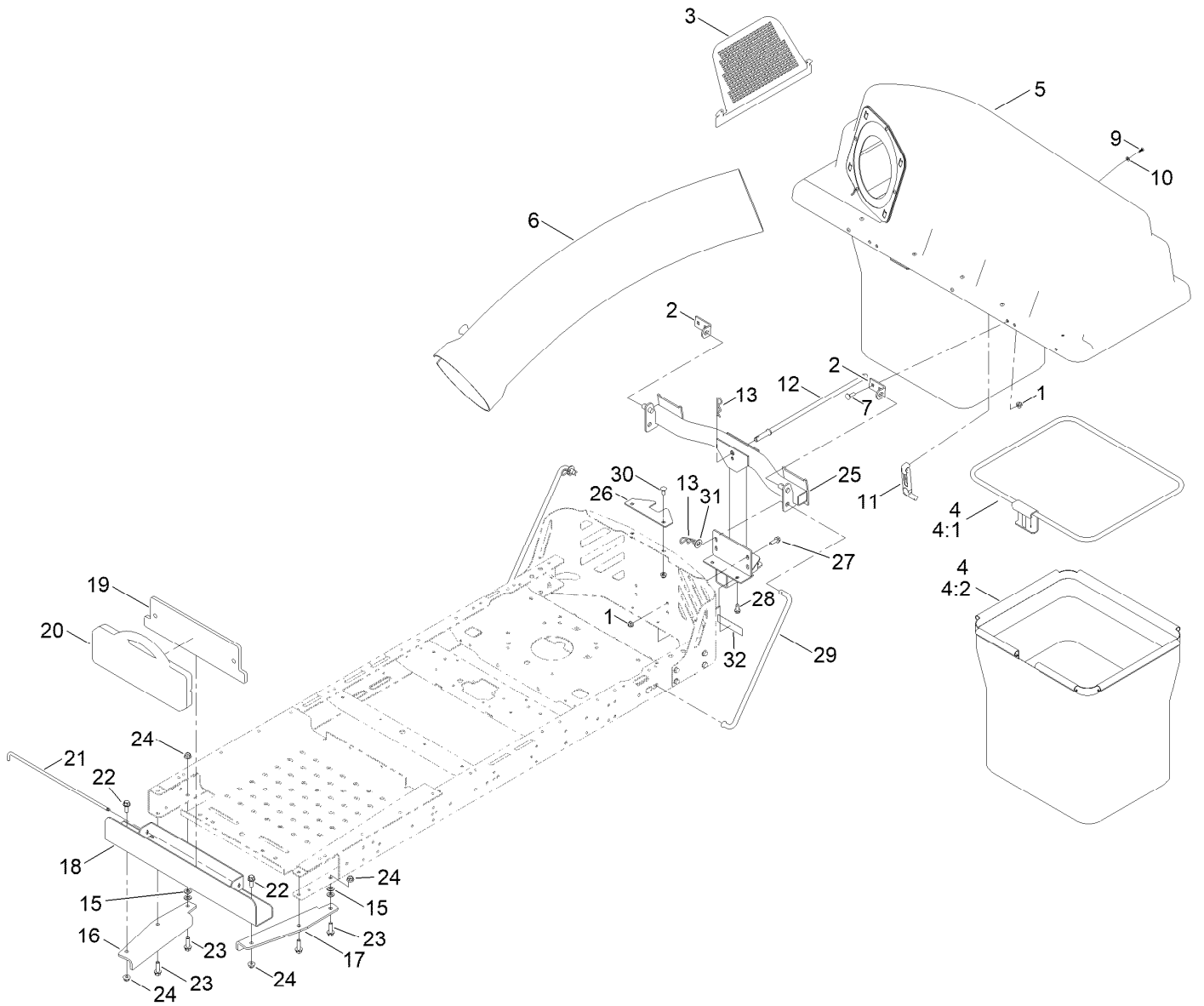

Frame and Bag Assembly (continued)

<i>Ref.</i>	<i>Part Number</i>	<i>Qty.</i>	<i>Description</i>	<i>Ref.</i>	<i>Part Number</i>	<i>Qty.</i>	<i>Description</i>
1	104-8300	8	Nut-HF, NI	17	120-5497-03	1	Bracket-Bagger Weight, LH
2	112-3987	2	Bracket-Pivot, Hopper	18	120-5491-03	1	Channel-Weight, Bagger
3	112-3993	1	Screen-Bagger	19	120-5495-03	1	Plate
4	147-2888	2	Bag ASM	20	109-9742-05	1	Weight-35 Pound
4:1	140-5179-03	1	Frame, Bag [black]	21	109-9759	1	Pin-Weight
4:2	140-5192	1	Bag ASM 20In Depth	22	3234-42	2	Screw-HHF
5	131-8654	1	Bagger Top ASM	23	119-4061	4	Screw-HHF
6	112-3995	1	Tube-Bagger	24	104-8301	4	Nut-HF, NI
7	3230-2	4	Bolt-CARR	25	144-1829-03	1	Frame ASM, Pivot [black]
9	132-6919	2	Screw-Plastic, PTH	26	131-3967-03	1	Bracket-Stabilizer
10	3256-77	2	Washer-Flat	27	3234-29	2	Screw-HHF
11	116-4992	1	Latch-Rubber	28	32144-70	2	Screw-HWHTF
12	131-4189	1	Rod-Hood, Down	29	119-8853	2	Rod-Support
13	3290-355	3	Pin-Hair	30	3230-1	2	Bolt-CARR
15	3256-24	4	Washer-Plain	31	3256-26	2	Washer-Flat
16	120-5502-03	1	Bracket-Bagger Weight, RH	32	131-4036	1	Decal

Bagger Top Assembly No. 131-8654

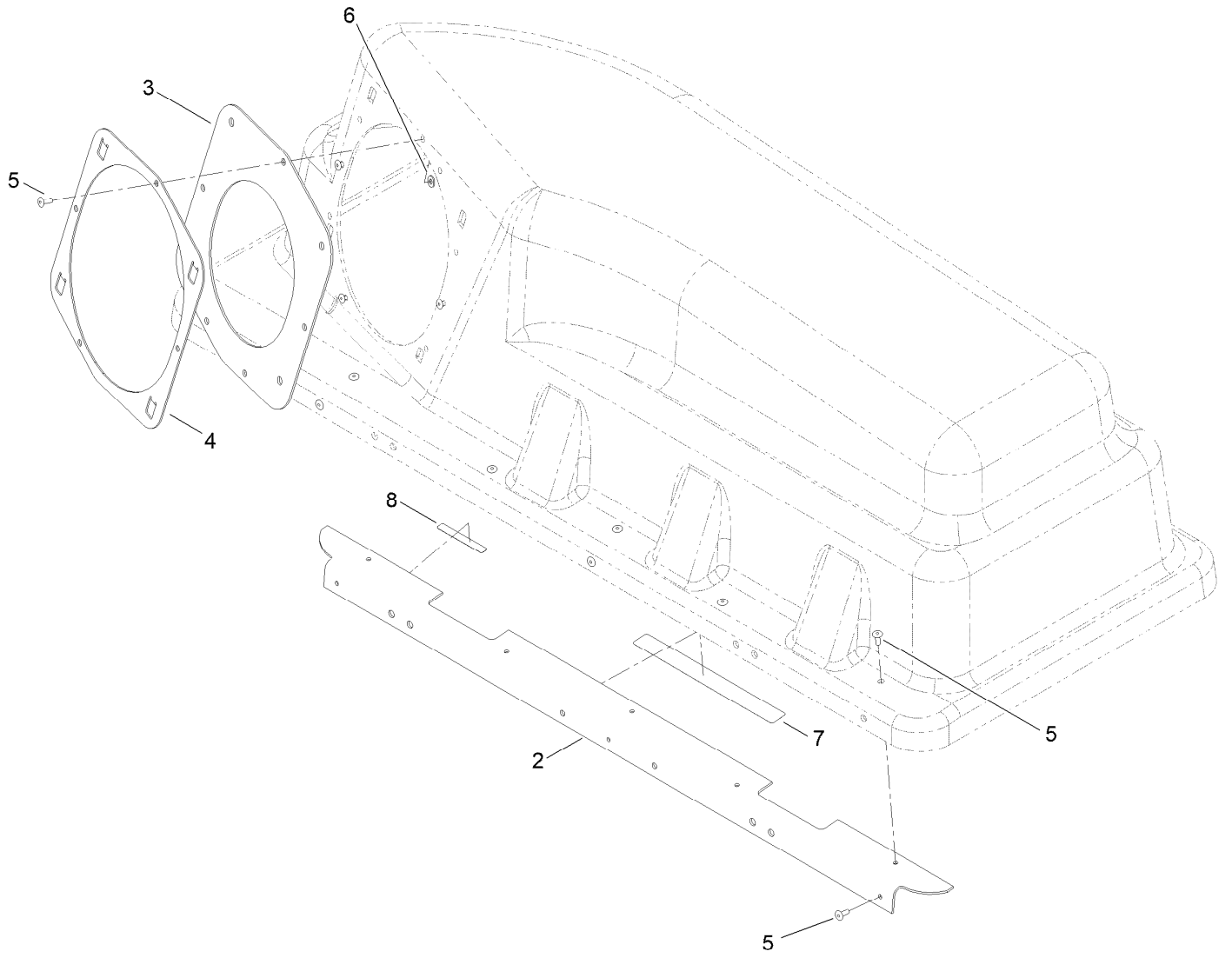

Bagger Top Assembly No. 131-8654 (continued)

<i>Ref.</i>	<i>Part Number</i>	<i>Qty.</i>	<i>Description</i>	<i>Ref.</i>	<i>Part Number</i>	<i>Qty.</i>	<i>Description</i>
2	116-1242-03	1	Stiffener-Bagger Top	6	137-3073	4	Washer-Plain
3	112-4001	1	Gasket	7	109-6809	1	Decal-Caution, Bagger
4	112-4000-03	1	Ring-Retainer	8	133-8061	1	Decal-Warning
5	114439	12	Rivet-Blind				

50 Inch Chute Mounting Assembly

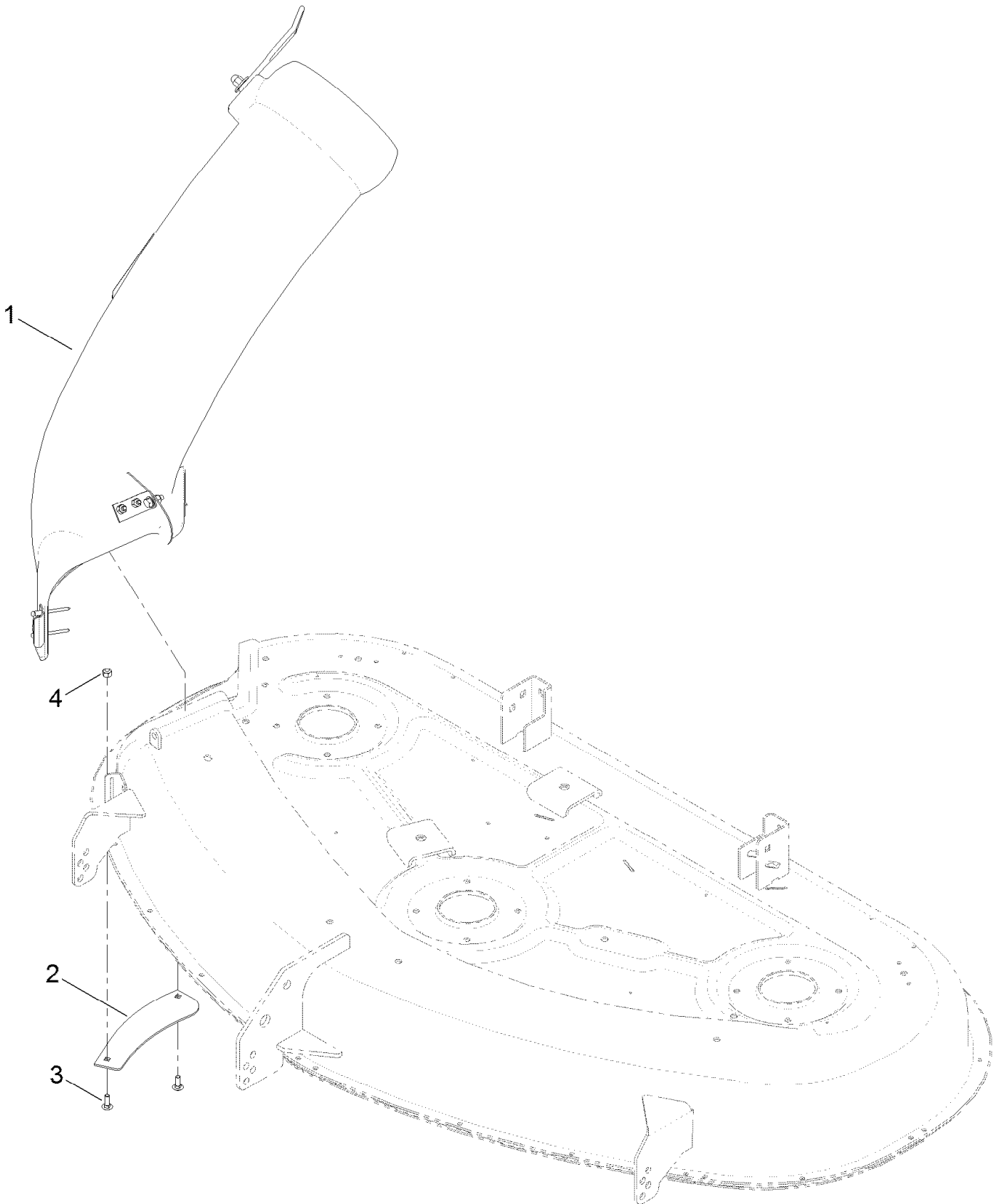

50 Inch Chute Mounting Assembly (continued)

<i>Ref.</i>	<i>Part Number</i>	<i>Qty.</i>	<i>Description</i>	<i>Ref.</i>	<i>Part Number</i>	<i>Qty.</i>	<i>Description</i>
1	119-8864	1	50 Inch Chute ASM	3	3229-1	2	Screw-CARR
2	131-8672-03	1	Baffle-Blowout	4	3296-42	2	Nut-Lock, NI

50 Inch Chute Assembly No. 119-8864

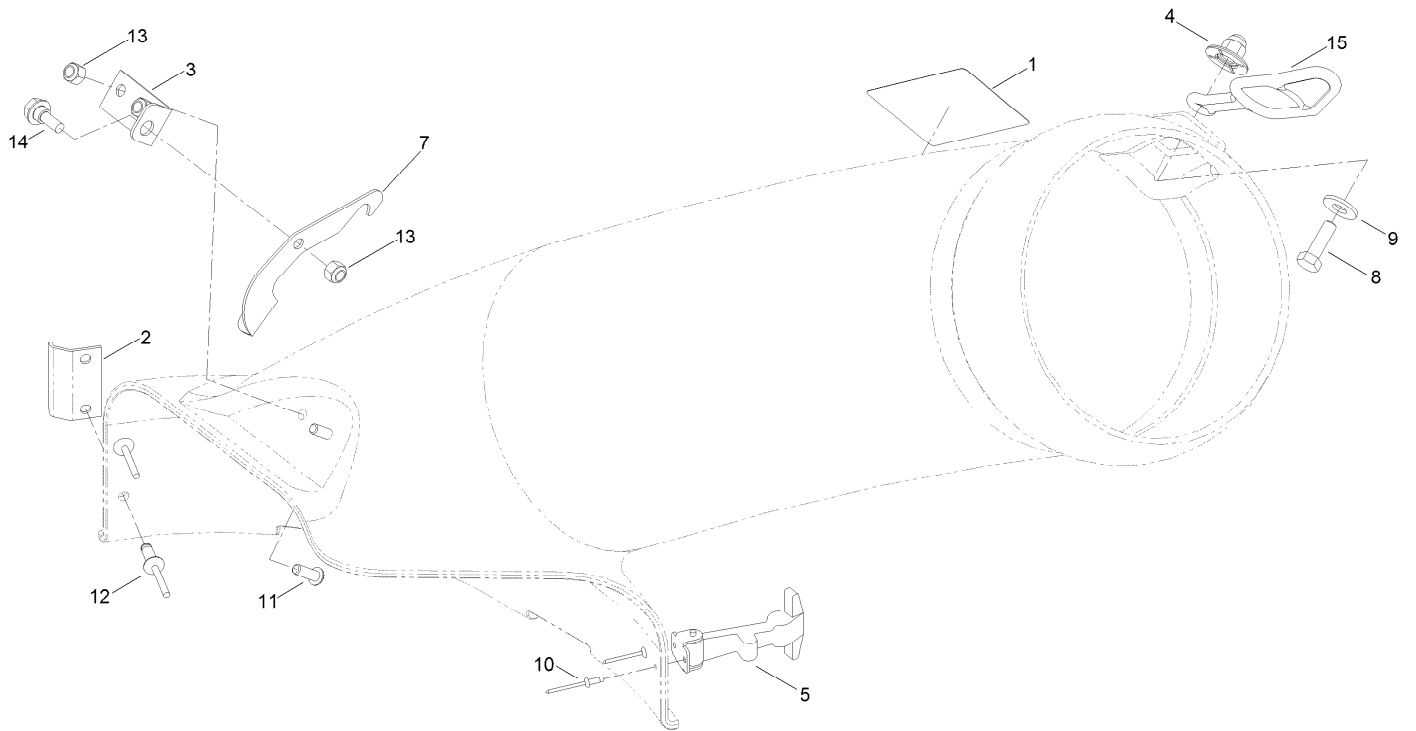

50 Inch Chute Assembly No. 119-8864 (continued)

<i>Ref.</i>	<i>Part Number</i>	<i>Qty.</i>	<i>Description</i>	<i>Ref.</i>	<i>Part Number</i>	<i>Qty.</i>	<i>Description</i>
1	110-6691	1	Decal-Danger	9	3256-3	1	Washer-Flat
2	112-3981	1	Bracket-Elbow	10	3269-31	2	Rivet-Pop
3	112-4038	1	Plate-Pivot	11	3274-69	2	Screw-HSBH
4	114-9015	1	Nut-Impeller	12	3290-412	2	Rivet-Blind
5	117344	1	Handle ASM	13	3296-42	3	Nut-Lock, NI
7	120-2216	1	Latch	14	120-7024	1	Screw-Shoulder, HWH
8	322-5	1	Screw-HH	15	82-5690	1	Retainer-Duct

