



EU Road Light Kit

Groundsmaster® e3200 Series Traction Unit

Model No. 32308

Installation Instructions

Installation

1

Preparing the Machine

No Parts Required

Procedure

1. Park the machine on a level surface.
2. Ensure that the parking brake is engaged; refer to your *Operator's Manual*.
3. Lower the cutting unit (if equipped).
4. Shut off the machine and remove the key.
5. Turn the battery-disconnect switch to the OFF position.



2

Installing the Clips and Speed Nuts

Parts needed for this procedure:

1	Switch mount
6	Clip (1/4 inch)
2	Speed nut
1	Fuse mount plate
2	U-type speed nut

Procedure

1. Install the 6 clips and 2 speed nuts to the switch mount (Figure 1).

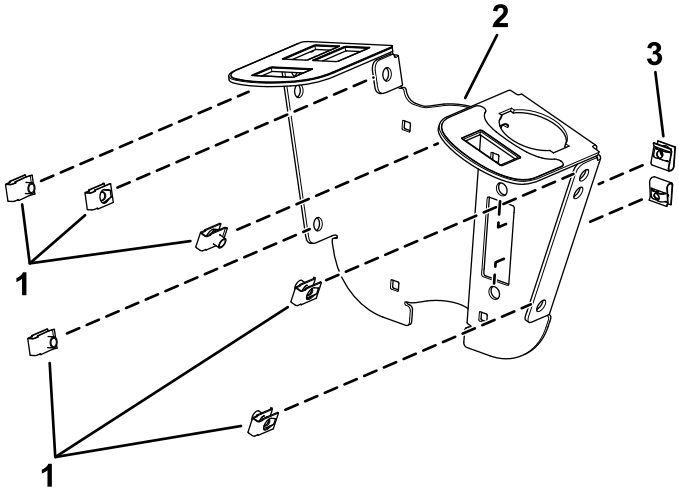

Figure 1

g319851

1. Clip
2. Switch mount
3. Speed nut

2. Install the U-type speed nuts to the fuse-mount plate (Figure 2).

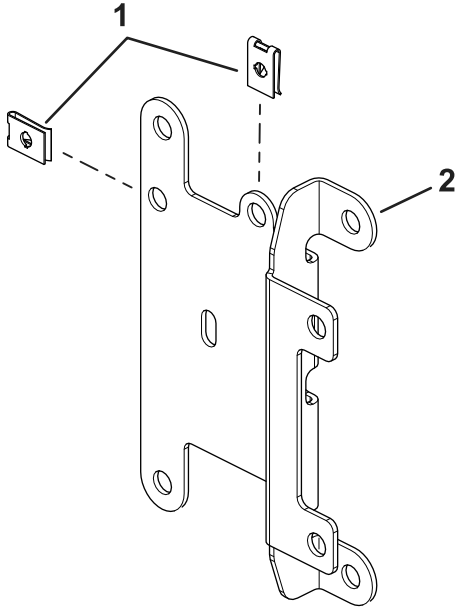

Figure 2

g460351

1. U-type speed nuts
2. Fuse-mount plate

3

Installing the Switch Mount

Parts needed for this procedure:

2	Mount bracket
4	Carriage bolt (1/4 x 2 inches)
2	Locknut (1/4 inch)
2	Hex-head screw (1/4 x 3/4 inch)
2	Flange nut (1/4 inch)
1	Flasher
1	Wire harness
2	Cable tie
1	Fuse cover
2	Thumb screw
2	Push nut
2	Screw (#10 x 3/8 inch)
1	Multi-function switch
3	Hole plug
1	Rocker switch
1	Control cover
6	Hex-head screw (1/4 x 3/4 inch)
2	Switch clip
2	Push rivet

Procedure

- Loosely install the switch mount around the steering column using 4 carriage bolts (1/4 x 2 inches), 2 mounting brackets, fuse-mount plate, and 4 locknuts (1/4 inch) as shown in [Figure 3](#).

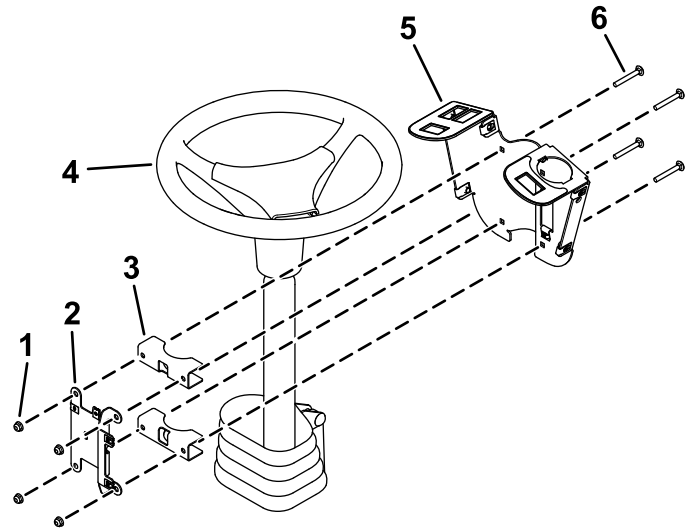

Figure 3

g319856

- | | |
|------------------------|-----------------------------------|
| 1. Locknuts (1/4 inch) | 4. Steering column |
| 2. Fuse-mount plate | 5. Switch mount |
| 3. Mounting brackets | 6. Carriage bolt (1/4 x 2 inches) |

2. Install the multi-function switch to the switch mount and secure it using the switch clips under the hole for the switch ([Figure 4](#)).

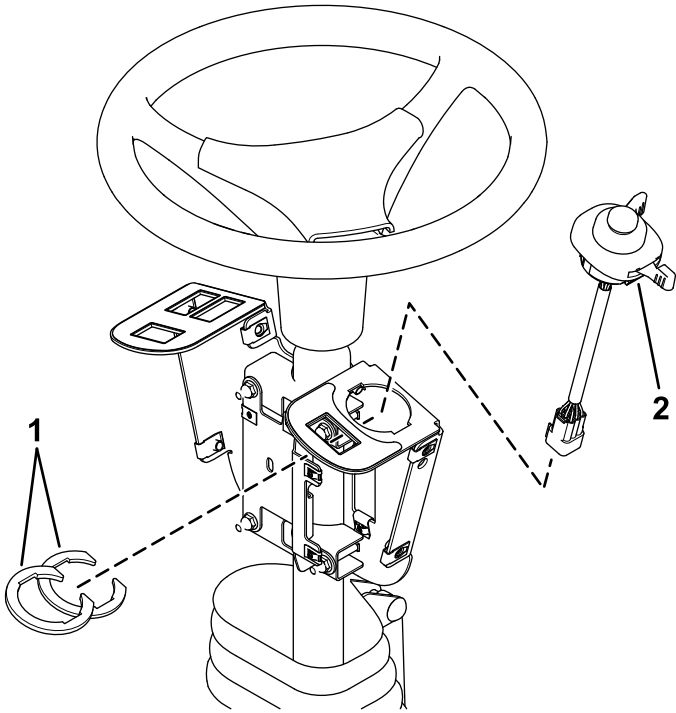

Figure 4

1. Switch clips
2. Multi-function switch

g319854

3. Install the rocker switch and hole plugs into the switch mount ([Figure 5](#)).

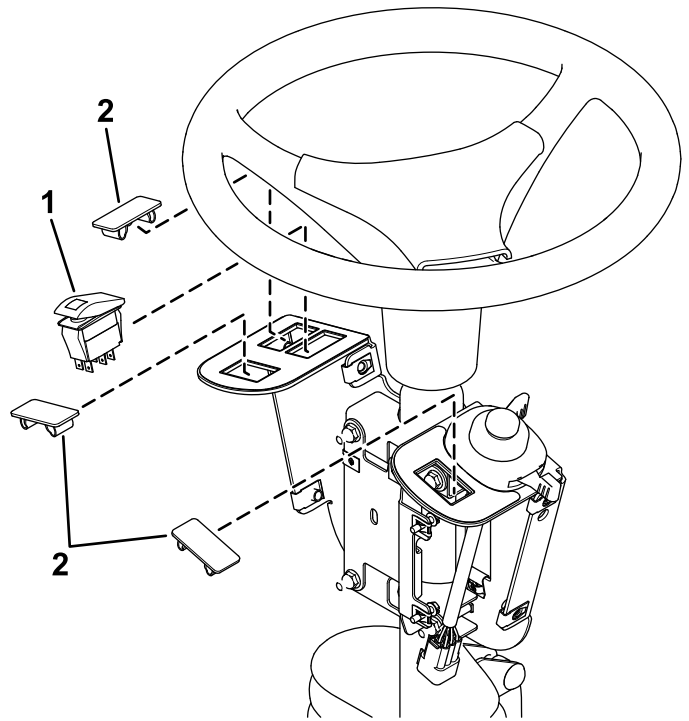

Figure 5

1. Rocker switch
2. Hole plug

g319855

4. Install the flasher to the fuse-mount plate using a screw (#10 x 3/8 inch) as shown in [Figure 6](#).

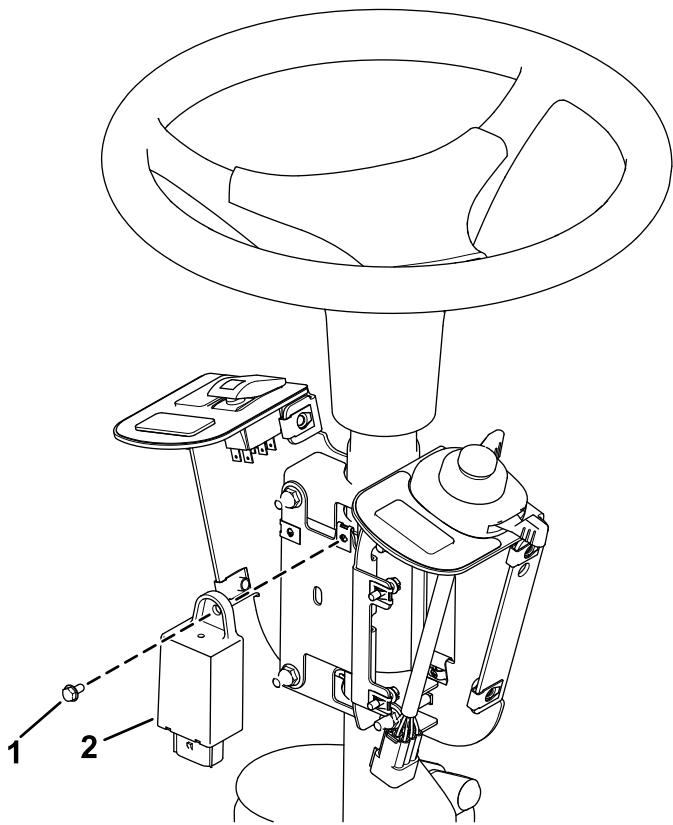

Figure 6

1. Screw (#10 x 3/8 inch) 2. Flasher

g460352

5. Secure the flasher using a cable tie ([Figure 7](#)).
6. Plug the harness into the rocker switch and multi-function switch ([Figure 7](#)).

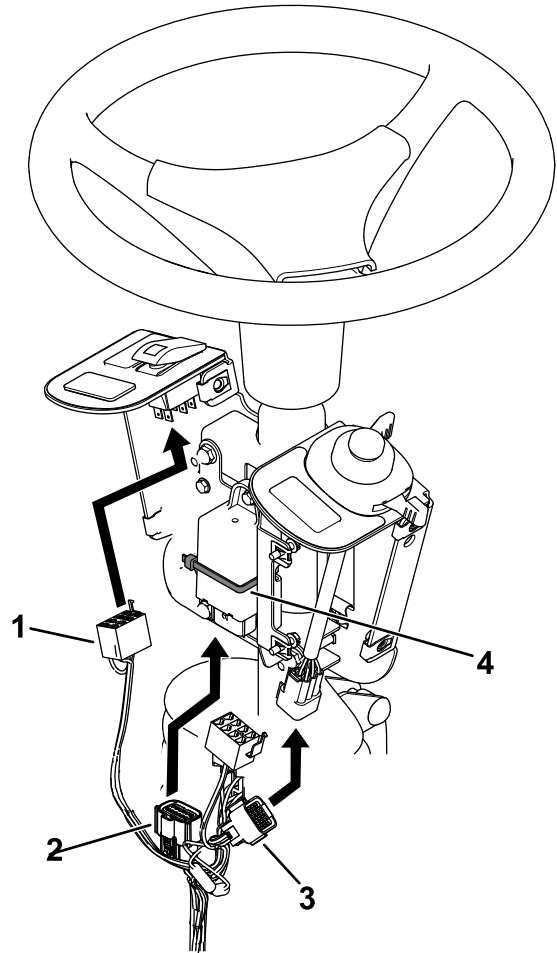

Figure 7

- | | |
|----------------------------|---------------------|
| 1. Rocker switch connector | 3. Switch connector |
| 2. Flasher connector | 4. Cable tie |

g460353

7. Plug the wire harness into the flasher ([Figure 7](#)).
8. Loosen the bolts around the steering-column base ([Figure 8](#)).
9. Raise the base up and drill a 22 mm (7/8 inch) hole as shown in [Figure 8](#).

⚠ WARNING

Using a drill without proper eye protection may allow debris to enter the eye, causing injury.

When drilling, always wear eye protection.

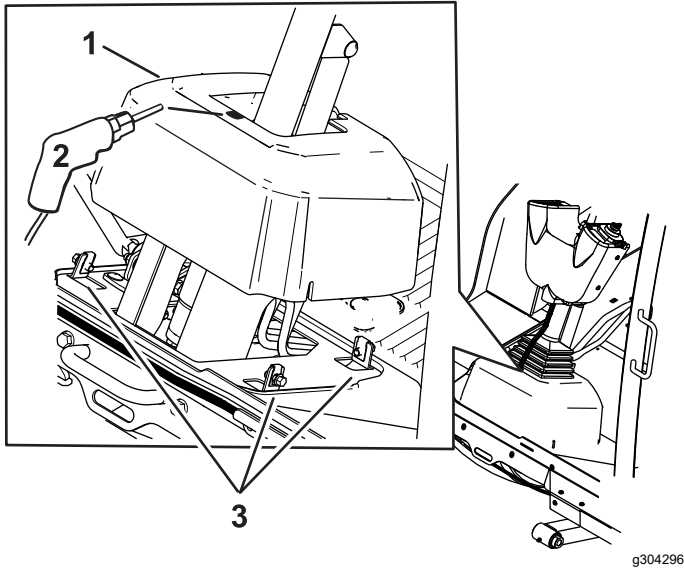

Figure 8

- 1. Steering-column base
- 2. 22 mm (7/8 inch) hole
- 3. Bolts

- 11. Install the fuse cover to the switch mount using 2 thumb screws and 2 push nuts (Figure 9).

Note: Ensure that the push nuts are installed on the inside of the fuse cover (Figure 9).

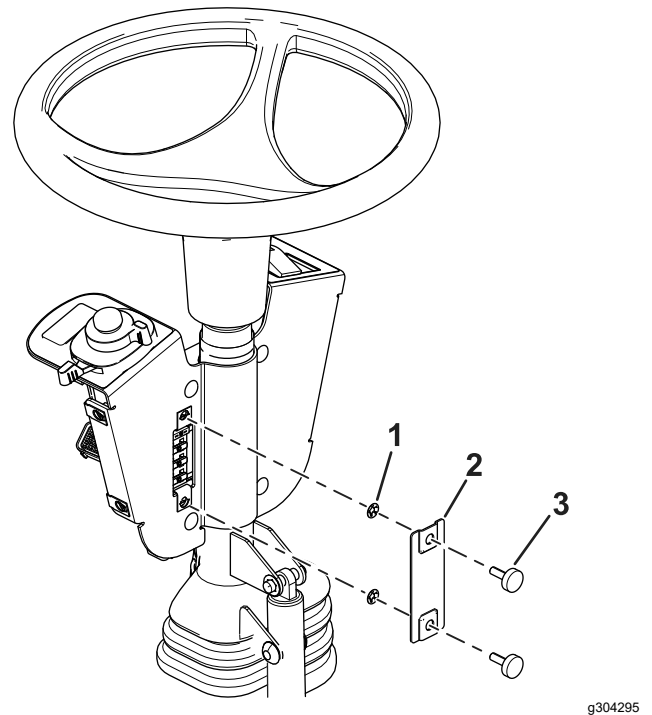

Figure 9

- 1. Push nut
- 2. Fuse cover
- 3. Thumb screw

- 10. Route the harness through the hole you drilled in the base.

- 12. Adjust the control assembly so that the switches are accessible.
- 13. Tighten all the fasteners.
- 14. Install the control cover to the switch mount using 2 push rivets and 6 hex-head screws (1/4 x 3/4 inch) as shown in Figure 10.

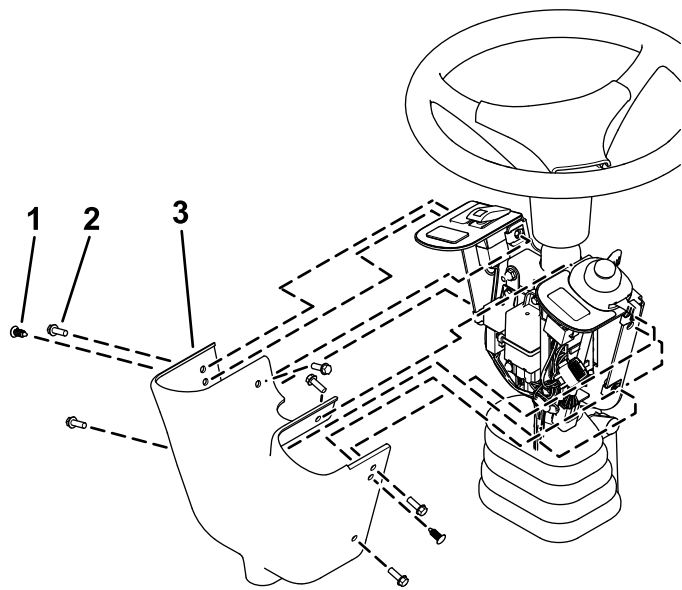

Figure 10

g319852

- 1. Push rivet
- 2. Hex-head screw
- 3. Control cover

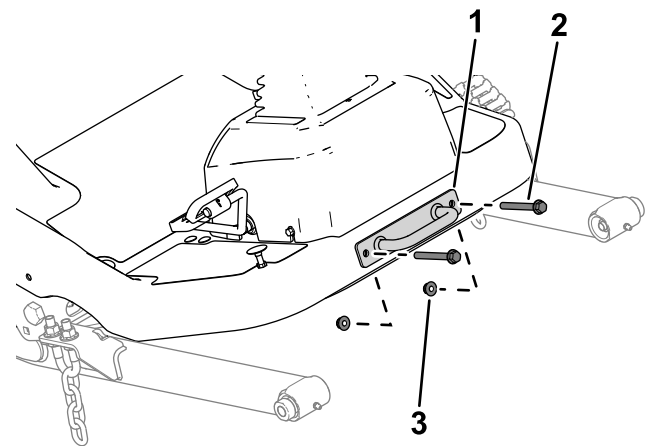

Figure 11

g299562

- 1. Tie-down bracket
- 2. Bolt
- 3. Nut

- 2. Secure the light cross mount to the platform using the previously removed bolts, nuts, and tie-down bracket (Figure 12).

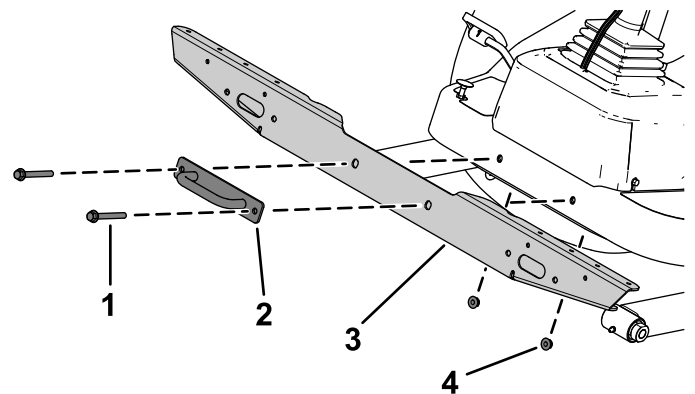

Figure 12

g305380

- 1. Bolt
- 2. Tie-down bracket
- 3. Light cross mount
- 4. Nut

- 3. Secure the left light mount and right light mount to the light cross mount using 3 button-head bolts (1/4 x 5/8 inch) through the speed nuts on each side (Figure 13).

4

Installing the Front Components

Parts needed for this procedure:

1	Left light mount
1	Right light mount
1	Left light assembly
1	Right light assembly
6	Button-head bolt (1/4 x 5/8 inch)
4	Locknut (3/8 inch)
1	Light cross mount

Procedure

- 1. Remove the tie-down bracket from the platform (Figure 11).
Retain the parts.

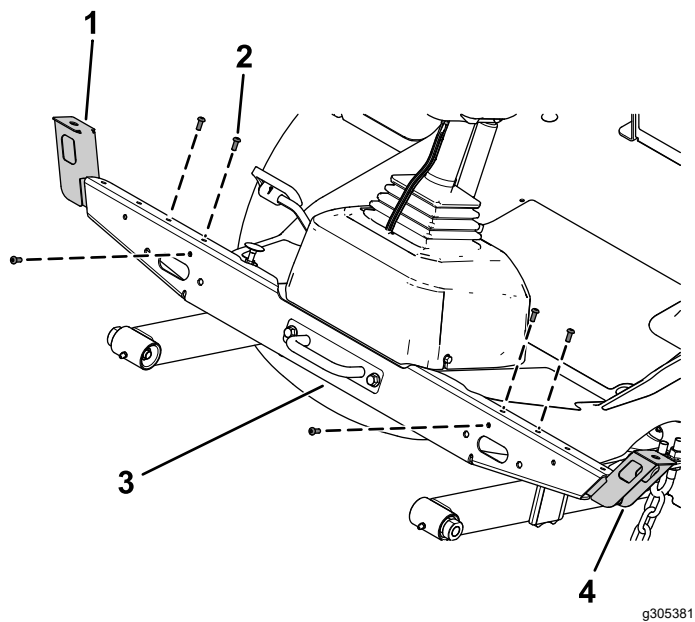

Figure 13

- | | |
|--------------------------------------|----------------------|
| 1. Right light mount | 3. Light cross mount |
| 2. Button-head bolt (1/4 x 5/8 inch) | 4. Left light mount |

- Secure the left light assembly and right light assembly to the left light mount and right light mount using the lock washer and hex nut on the light assemblies (Figure 14).

Note: Install the lights with the low beam toward the outer edge of the machine.

Look at the bottom of the lights for high beam and low beam orientation.

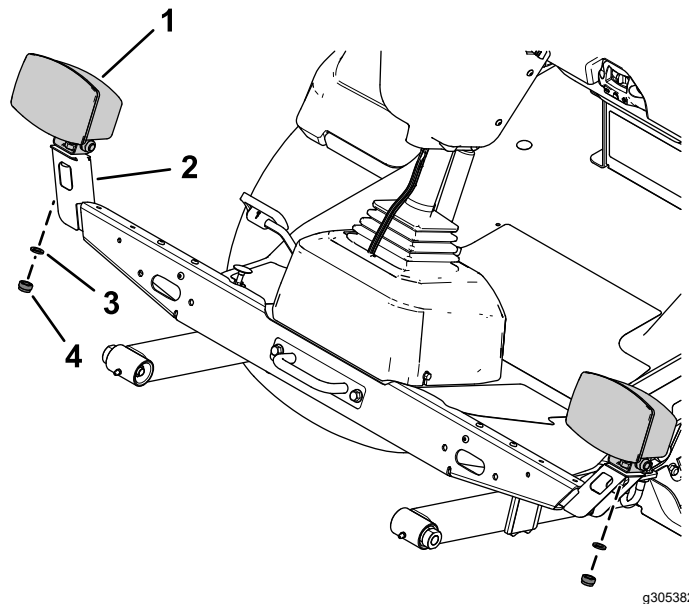

Figure 14

- | | |
|-------------------|----------------|
| 1. Light assembly | 3. Lock washer |
| 2. Light mount | 4. Hex nut |

5

Installing the Rear Components

Parts needed for this procedure:

1	Left mount
1	Right mount
1	Left short mount
1	Right short mount
1	Right long mount
4	Carriage bolt (5/16 x 3/4 inch)
4	Flange nut (5/16 inch)
4	Carriage bolt (1/4 x 5/8 inch)
9	Locknut (1/4 inch)
2	Inner mount assembly
2	Taillight
4	Pan-head screw (#10 x 1-1/4 inches)
4	Flange nut (#10)
4	Hex-head bolt (3/8 x 3-1/4 inches)
4	Locknut (3/8 inch)
1	Marker mount
1	Speed-plate mount
5	Carriage bolt (1/4 x 1/2 inch)
1	Horn mount bracket
1	Horn
3	Speed decal
1	Left light housing
1	Right light housing

Procedure

1. Remove the flange-head bolt (3/8 x 3 inches) and flange nut (3/8 inch) securing the bumper to the rear tube frame on each side of the bumper (Figure 15).

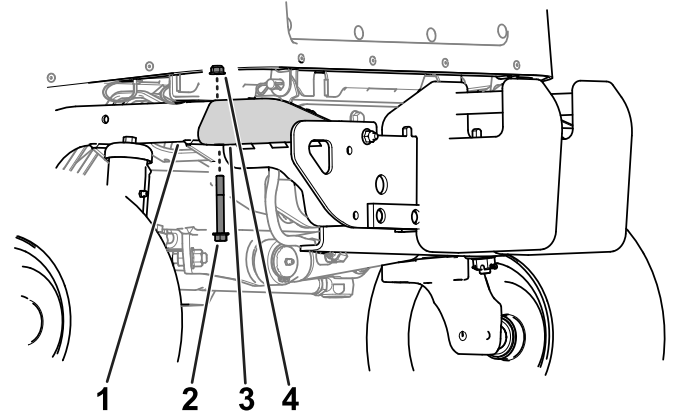

Figure 15

1. Rear tube frame
2. Flange-head bolt (3/8 x 3 inches)
3. Bumper
4. Flange nut (3/8 inch)

2. Slightly raise the battery tray and insert the left mount and right mount between the battery tray and the tube frame (Figure 16).

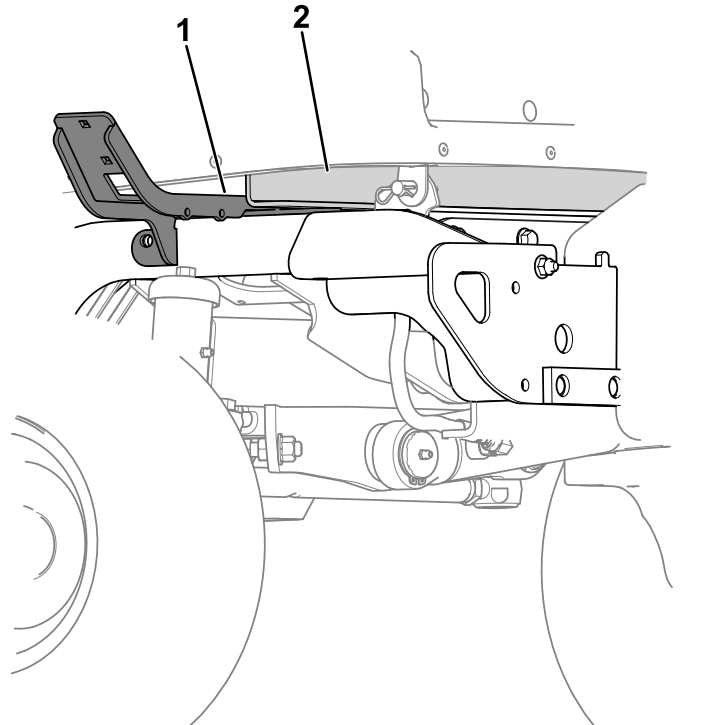

Figure 16

1. Left mount
2. Battery tray

3. Secure the left mount and right mount to rear frame tubes using 4 hex-head bolts (3/8 x 3-1/4 inches)

inches) and 4 locknuts (3/8 inch) on each side (Figure 17).

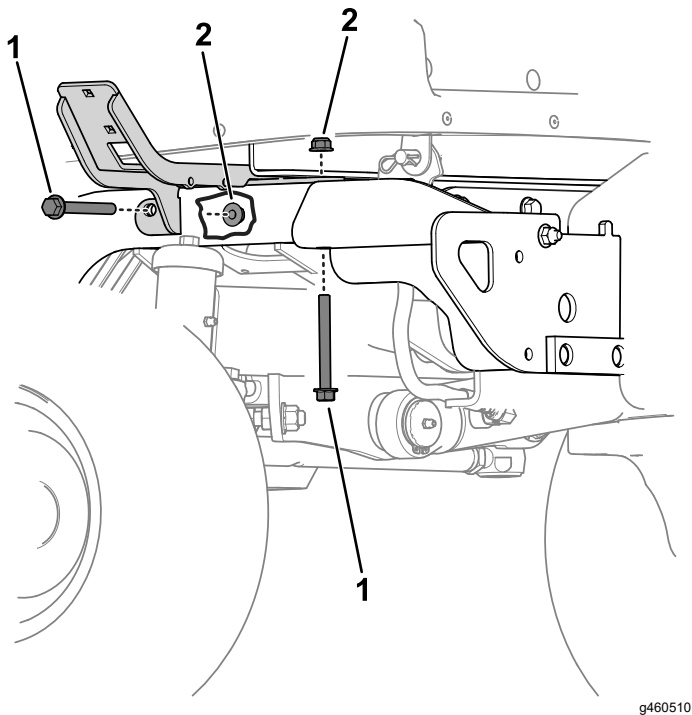

Figure 17

- | | |
|-----------------------|---------------------------------------|
| 1. Locknut (3/8 inch) | 2. Hex-head bolt (3/8 x 3-1/4 inches) |
|-----------------------|---------------------------------------|

4. Secure the left short mount the left mount using 2 carriage bolts (5/16 x 3/4 inch) and 2 flange nuts (5/16 inch) as shown in Figure 18.

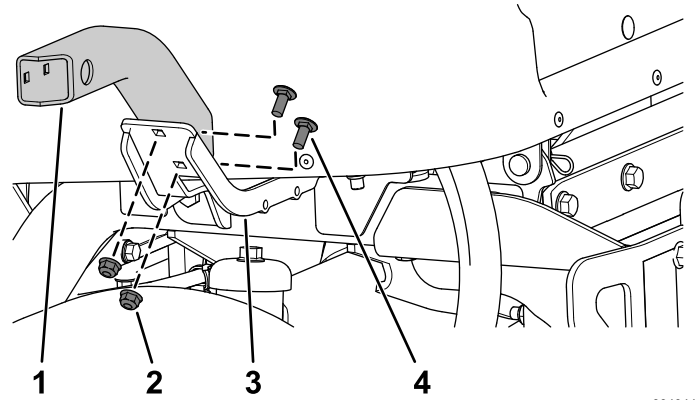

Figure 18

- | | |
|---------------------------|------------------------------------|
| 1. Left short mount | 3. Left mount |
| 2. Flange nut (5/16 inch) | 4. Carriage bolt (5/16 x 3/4 inch) |

5. Perform the following step for the cutting unit that is equipped on your machine:

- **Model 31980 equipped:** Secure the right long mount (Figure 19) to the right mount using 2 carriage bolts (5/16 x 3/4 inch) and 2 flange nuts (5/16 inch).
- **Model 31981 equipped:** Secure the right short mount (Figure 19) to the right mount using 2 carriage bolts (5/16 x 3/4 inch) and 2 flange nuts (5/16 inch).

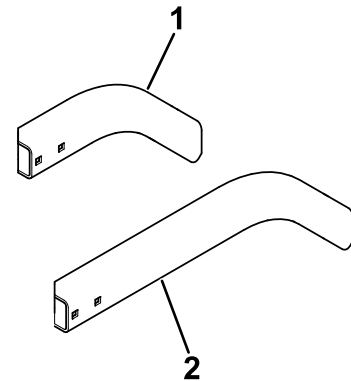

Figure 19

- | | |
|----------------------|---------------------|
| 1. Right short mount | 2. Right long mount |
|----------------------|---------------------|

6. Secure the left light housing and right light housing to the left short mount and right short

mount using 4 carriage bolts (1/4 x 5/8 inch) and 4 locknuts (1/4 inch) as shown in [Figure 20](#).

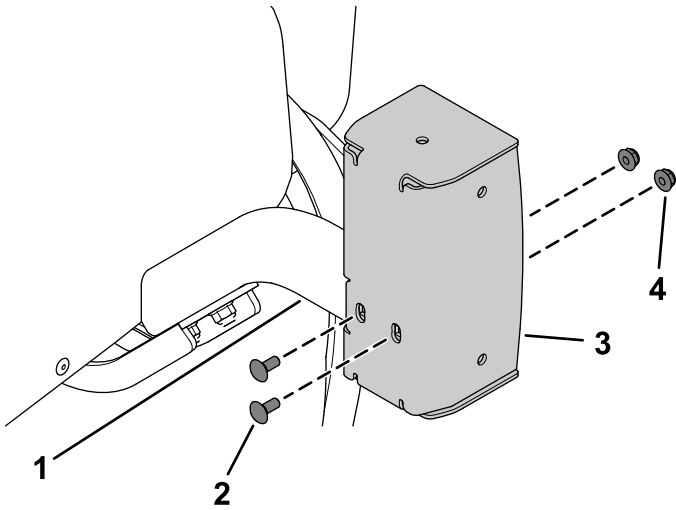

Figure 20

g319940

- | | |
|-----------------------------------|-----------------------|
| 1. Left short mount | 3. Left light housing |
| 2. Carriage bolt (1/4 x 5/8 inch) | 4. Locknut (1/4 inch) |

7. Apply a speed decal to the speed-plate mount ([Figure 21](#)).

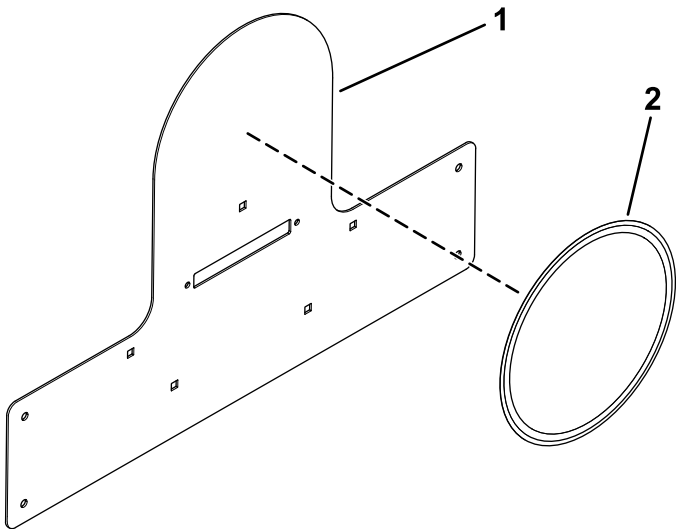

Figure 21

g304252

- | | |
|----------------------|----------------|
| 1. Speed-plate mount | 2. Speed decal |
|----------------------|----------------|

8. Secure the speed-plate mount to the marker mount using 5 carriage bolts (1/4 x 1/2 inch) and 5 locknuts (1/4 inch) as shown in [Figure 22](#).

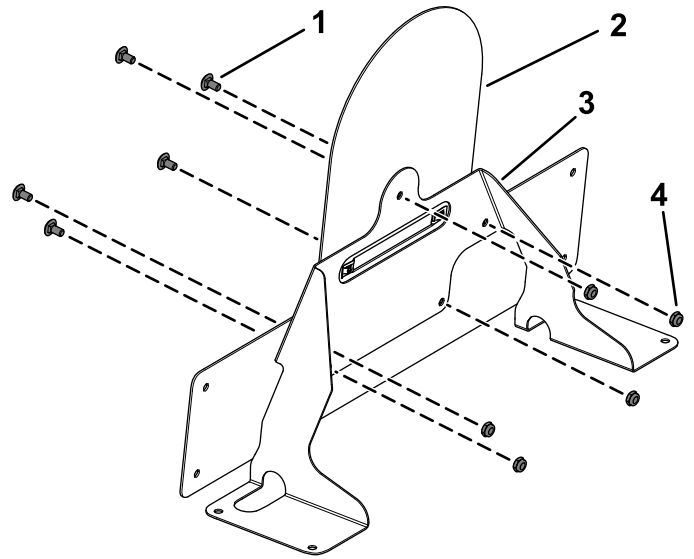

Figure 22

g304257

- | | |
|-----------------------------------|-----------------------|
| 1. Carriage bolt (1/4 x 1/2 inch) | 3. Marker mount |
| 2. Speed-plate mount | 4. Locknut (1/4 inch) |

9. Remove the 12 plastic plugs shown in [Figure 23](#) from the hood.

- Retain the 5 plugs shown in [Figure 23](#)
- Discard the 7 plugs shown in [Figure 23](#)

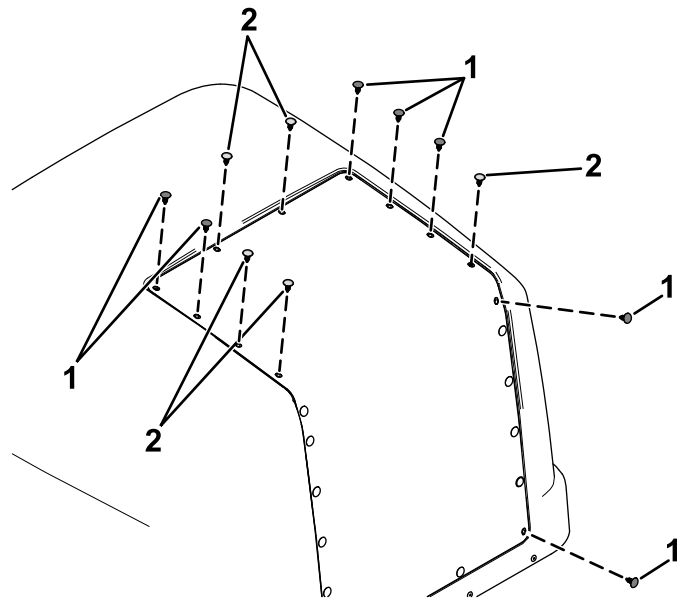

Figure 23

g460522

- | | |
|-------------------------|------------------------|
| 1. Plastic plug—discard | 2. Plastic plug—retain |
|-------------------------|------------------------|

10. Remove the plate under the hood cover ([Figure 24](#)).

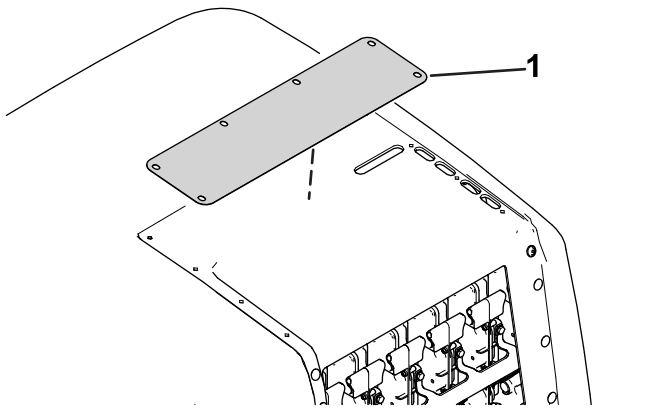

Figure 24

g460991

1. Plate

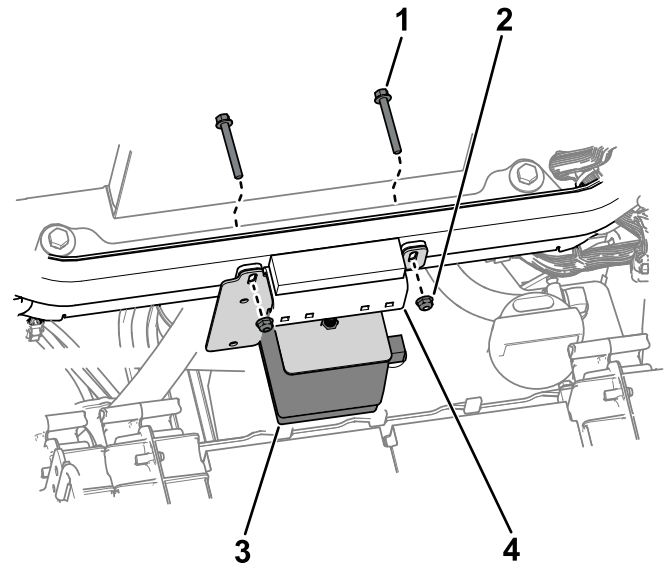

Figure 26

g455977

- | | |
|---------|--------------------------|
| 1. Bolt | 3. Horn on mount bracket |
| 2. Nut | 4. Hood support bracket |

11. Install the 5 plugs to the hood cover that you retained in step 9.
12. Raise the hood; refer to the traction unit *Operator's Manual*.
13. Use the existing nut on the horn to secure the horn to the horn mount bracket (Figure 25).

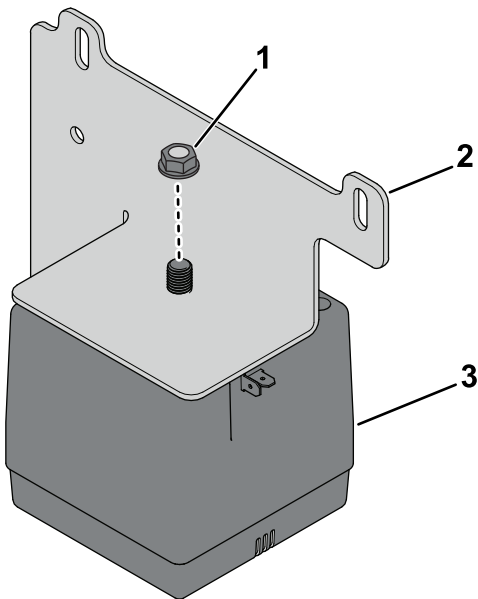

Figure 25

g455976

- | | |
|------------------|---------|
| 1. Nut | 3. Horn |
| 2. Mount bracket | |

14. Use the existing bolts and nuts from the hood support bracket to secure the horn mount bracket to the traction-unit frame.

15. Apply the speed decals to each side of the hood (Figure 27).

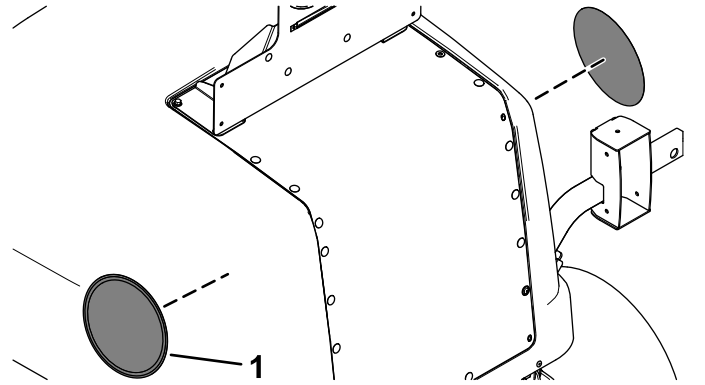

Figure 27

g304251

1. Speed decal

6

Routing the Light Wire Harness

Parts needed for this procedure:

1	Light wire harness
3	Flat washer
3	Hex-socket screw (1/4 x 1 inch)
3	Clamp
3	Flange nut (1/4 inch)
2	Inner mount assembly
2	Taillight
4	Pan-head screw (#10 x 1-1/4 inches)
4	Flange nut (#10)
8	Button-head bolt (1/4 x 3/4 inch)
1	Plate light
2	Screw (#6 x 1 inch)
2	Locknut (#6)
2	Back mount
4	Flange-head bolt (1/4 x 3/4 inch)
4	Locknut (1/4 inch)
9	Cable tie

Procedure

Refer to the following figures and instructions for routing the light wire harness.

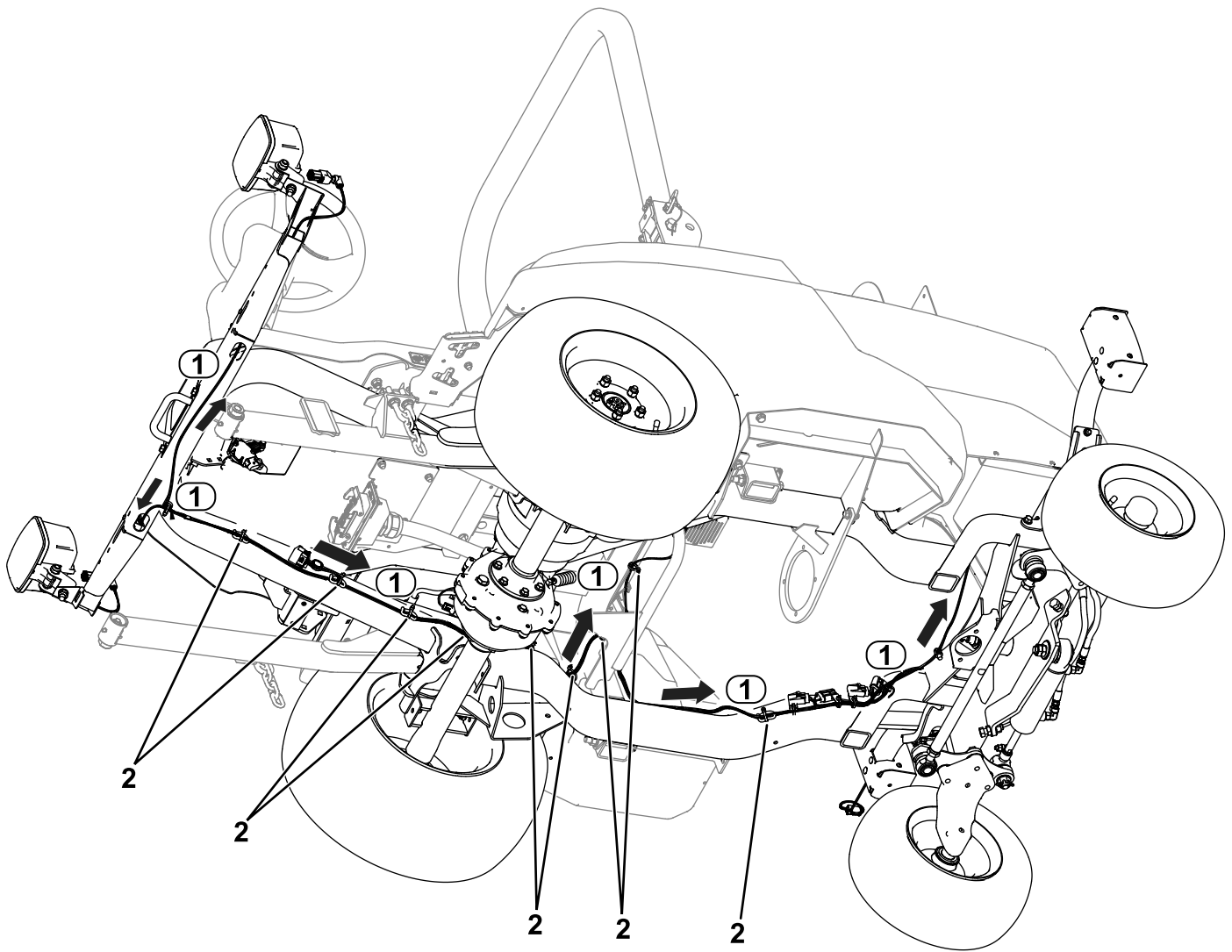

Figure 28

g456019

- 1. Wire-harness routing
- 2. Cable ties

1. Route the wire-harness connector labeled LH HEADLIGHT (P04) to the left side of the unit (Figure 28). Connect the harness to the light.
2. Route the wire-harness connector labeled RH HEADLIGHT (P05) to the right side of the unit (Figure 28). Connect the harness to the light.
3. Route the wire-harness connector labeled LH REAR LIGHT (P01) to the rear left side of the unit (Figure 28).
4. Route the wire-harness connector labeled RH REAR LIGHT (P02) to the rear right side of the unit (Figure 28).
5. Route the wire-harness connector labeled HORN (P13) to the horn. Connect the harness to the horn (Figure 29).

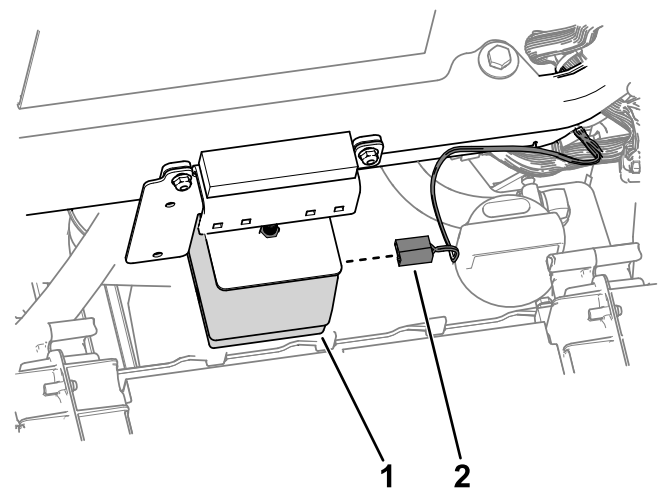

Figure 29

g456021

- 1. Horn
- 2. Wire-harness connector—HORN (P13)

- Secure the taillights to the inner mount assemblies using 4 pan-head screws (#10 x 1-1/4 inches) and 4 flange nuts (#10) as shown in [Figure 30](#).

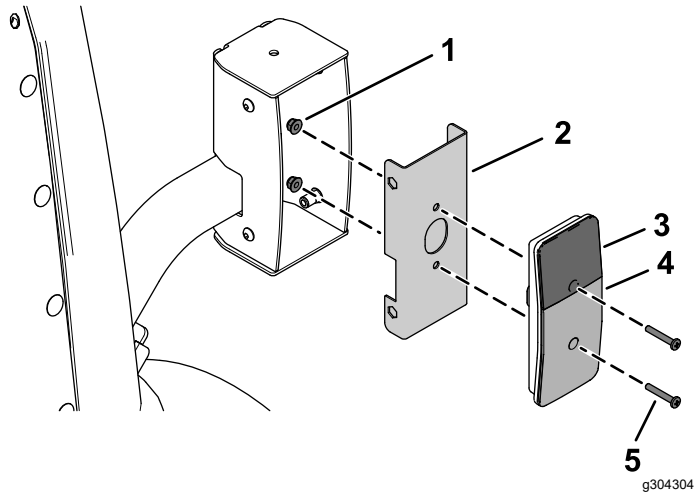

Figure 30

- | | |
|-------------------------|--|
| 1. Flange nut (#10) | 4. Red lens |
| 2. Inner mount assembly | 5. Pan-head screw (#10 x 1-1/4 inches) |
| 3. Amber lens | |

- Connect the wire-harness connector labeled LH REAR LIGHT (P01) to the rear light ([Figure 28](#)).
- Connect the wire-harness connector labeled RH REAR LIGHT (P02) to the rear light ([Figure 28](#)).

- Secure the assembled taillights to the taillight housings using 8 button-head bolts (1/4 x 3/4 inch) as shown in [Figure 31](#).

Ensure that you install the taillights with the yellow lens on top ([Figure 30](#) and [Figure 31](#)).

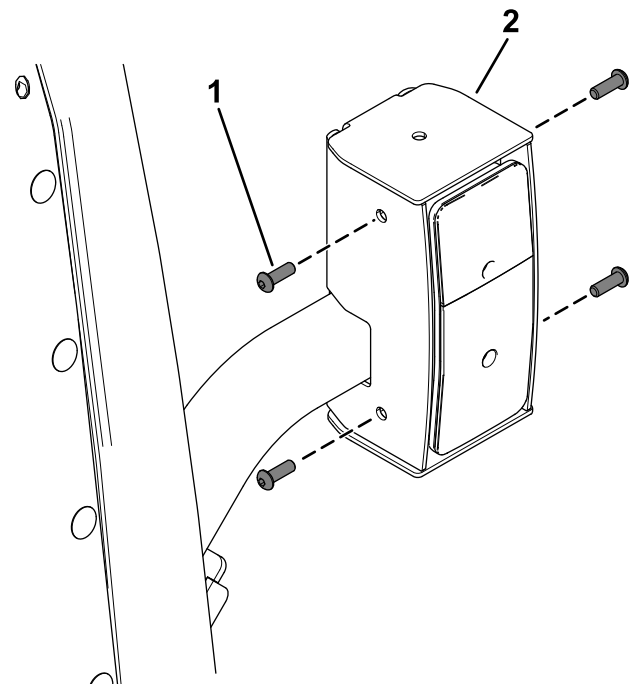

Figure 31

- | | |
|--------------------------------------|-----------------------|
| 1. Button-head bolt (1/4 x 3/4 inch) | 2. Taillight assembly |
|--------------------------------------|-----------------------|

- Route the wire-harness connector labeled LICENSE PLATE LIGHT (P14) through the hood and connect it to the license light (Figure 32).

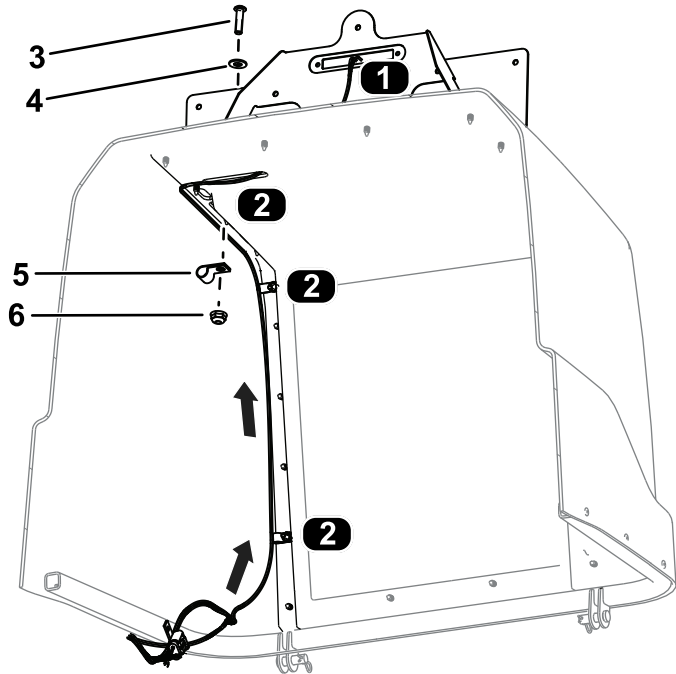

Figure 32

View from the bottom of the hood

- | | |
|--|--------------------------|
| 1. Wire-harness connection—license plate | 4. Flat washer |
| 2. Clamp locations | 5. Clamp |
| 3. Hex-socket screw (1/4 x 1 inch) | 6. Flange nut (1/4 inch) |

- Secure the wire harness to the hood using 3 hex-socket screws (1/4 x 1 inch), 3 flat washers, 3 clamps, and 3 flange nuts (1/4 inch) as shown in Figure 32.
- Secure the assembled speed-plate mount to the hood using 4 flange-head bolts (1/4 x 3/4 inch), 2 back mounts, and 4 locknuts (1/4 inch) as shown in Figure 33.

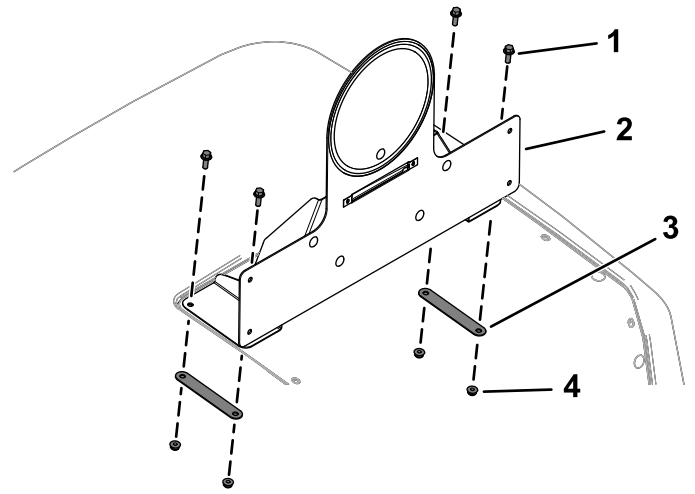

Figure 33

- | | |
|--------------------------------------|-----------------------|
| 1. Flange-head bolt (1/4 x 3/4 inch) | 3. Back mount |
| 2. Assembled speed-plate mount | 4. Locknut (1/4 inch) |

- Secure the plate light to the assembled speed-plate mount using 2 locknuts (#6) and 2 screws (#6 x 1 inch) as shown in Figure 34.

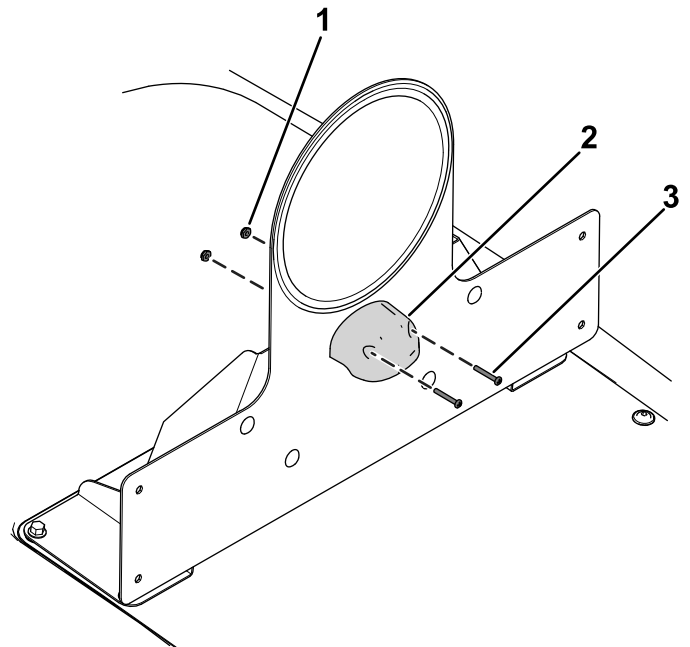

Figure 34

- | | |
|-----------------|------------------------|
| 1. Locknut (#6) | 3. Screw (#6 x 1 inch) |
| 2. Plate light | |

- Connect the wire harness to the plate light (Figure 34).
- Install cable ties to the wire harness as shown in Figure 28.

7

Routing the Control Wire Harness

Parts needed for this procedure:

1	Control wire harness
2	Cable tie

Procedure

1. Route the control wire harness through the platform opening (Figure 35).

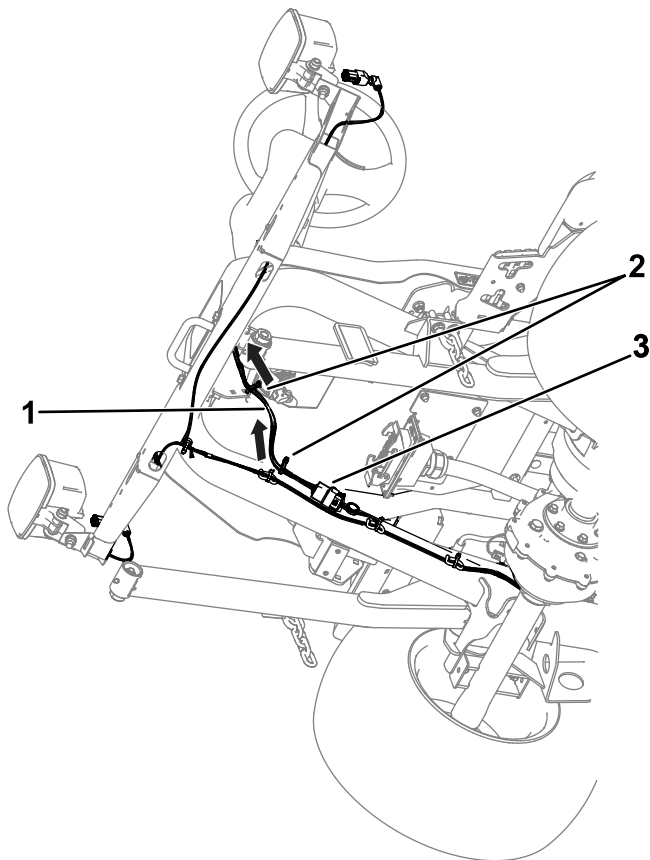

g456274

Figure 35

1. Control wire harness
2. Cable ties
3. Connection—control wire harness and light wire harness

2. Connect the control wire-harness connector labeled PLATFORM HARNESS (P71) to light wire-harness connector labeled To POD HARNESS (P03) (Figure 35).

8

Installing the Serial Plate

For Germany Only

Parts needed for this procedure:

1	Serial plate
1	Serial plate tape

Procedure

1. Stamp the serial number into the frame.
The text size must be 7 mm (1/4 inch) or larger.
2. Stamp the appropriate information into the serial plate.
3. Wipe down the bottom of the frame and serial plate with an alcohol-based wipe (Figure 36).

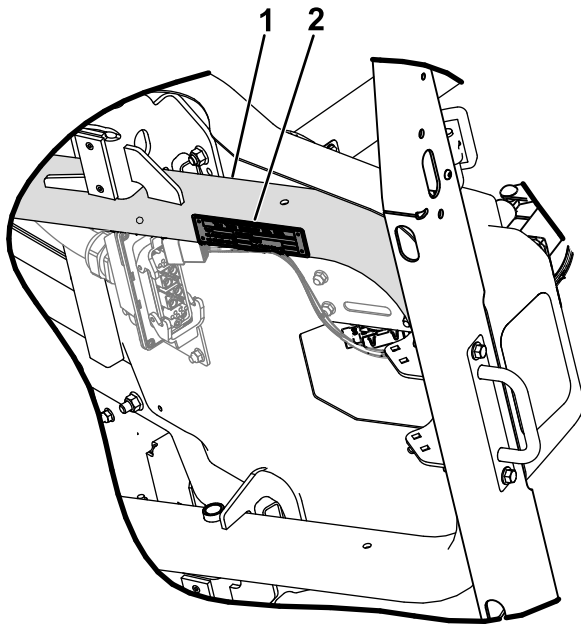

Figure 36

g460703

1. Clean the bottom of the frame.
2. Serial plate

4. Apply the tape to the serial plate.
5. Install the plate to the frame (Figure 37).
Use the dimensions shown in Figure 38.

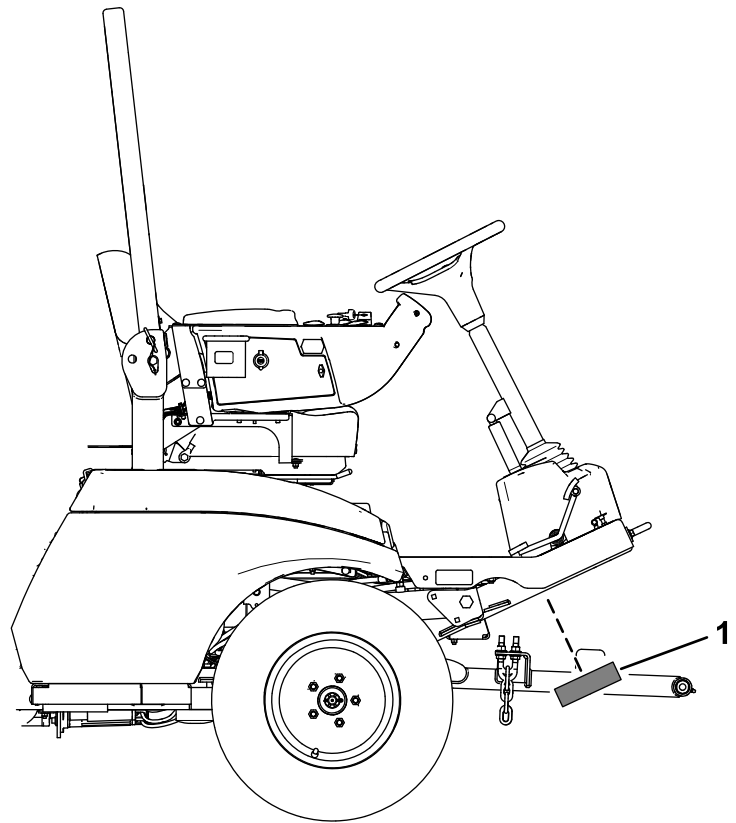

Figure 37

g460537

1. Serial plate

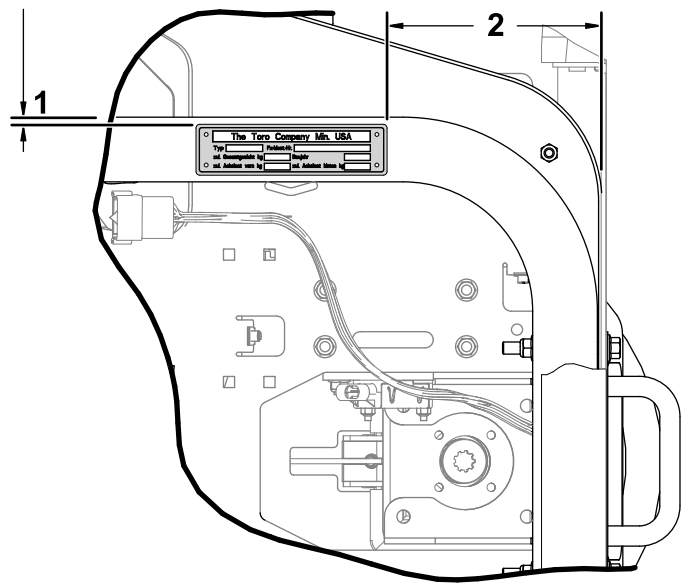

Figure 38

g460538

1. 2.5 to 8.1 mm (1/8 to 5/16 inch)
2. 162 to 168 mm (6-3/8 to 6-5/8 inches)

9

Installing the High-Voltage Decals

Parts needed for this procedure:

10	High-voltage decal
----	--------------------

Procedure

Apply the high-voltage decals to the following areas on traction unit and cutting unit:

- Cutting-unit motors (Figure 40)
- Cutting-unit controller cover (Figure 40)
- Hood (Figure 39 and Figure 41)
- Charger port/power-disconnect switch (Figure 41)
- Channel supports in the battery compartment (Figure 39)

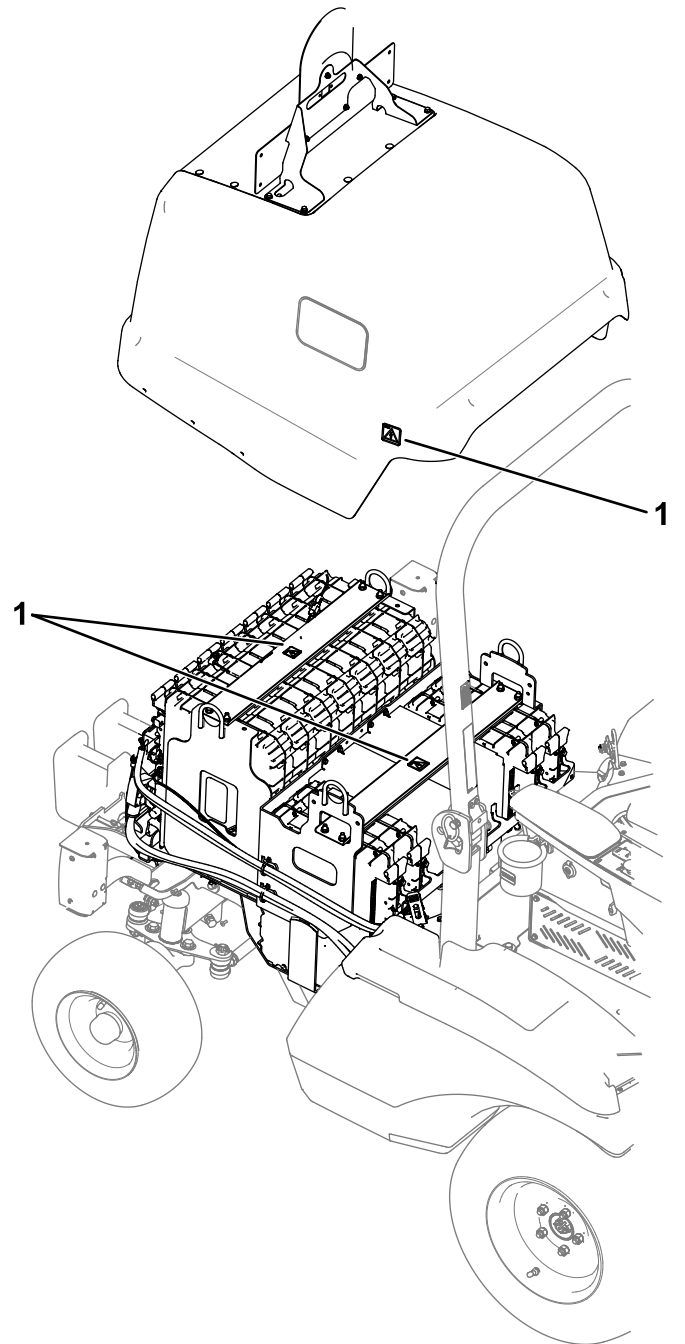

Figure 39

g459506

1. High voltage decal

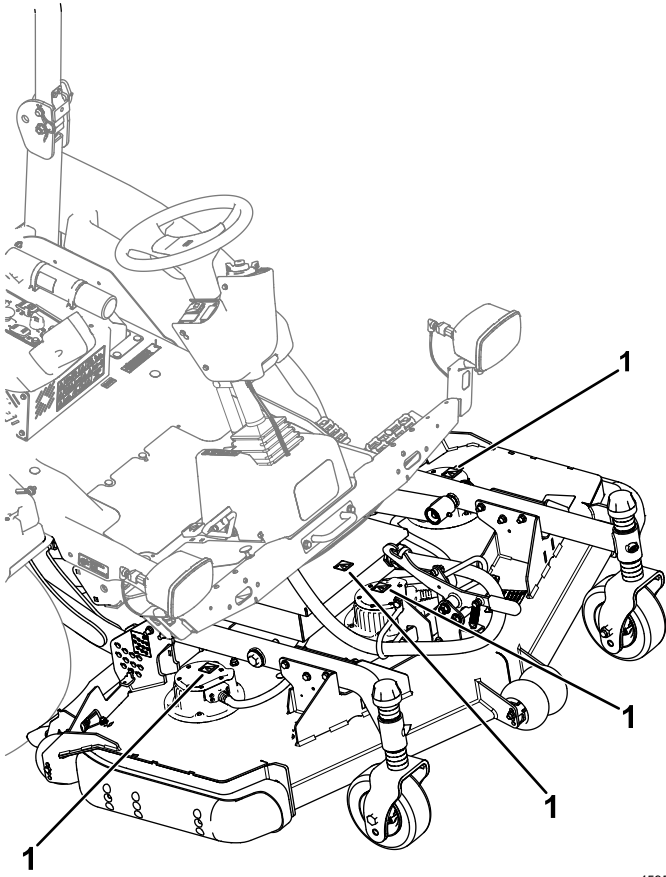

Figure 40

g459507

-
- 1. High voltage decal

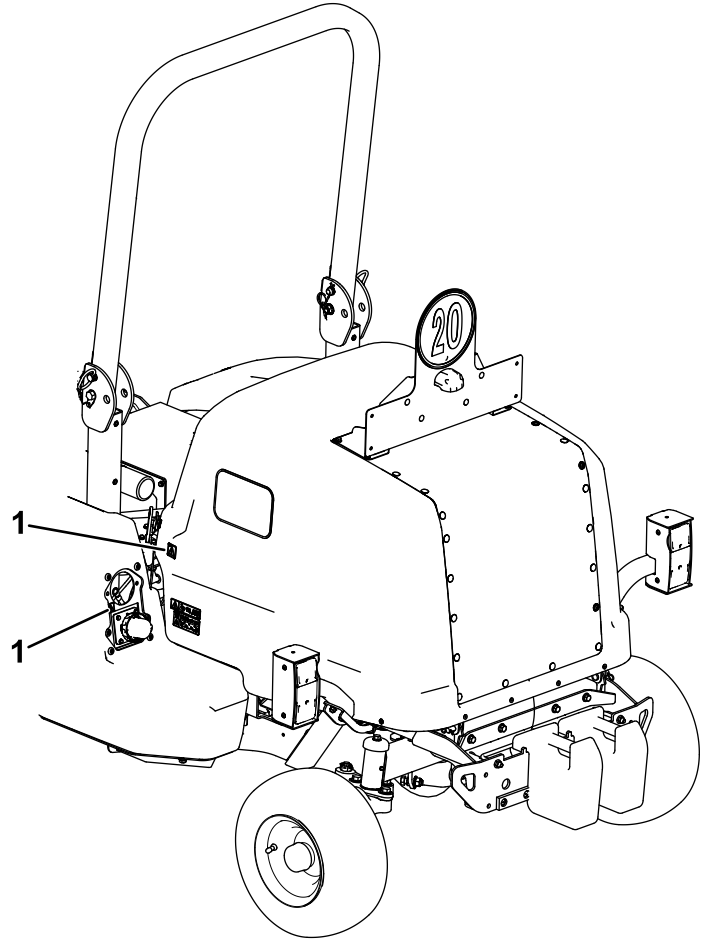

Figure 41

g459508

-
- 1. High voltage decal

10

Installing the Tube Wraps

Parts needed for this procedure:

1	Tube wrap (147 cm or 58 inches)
3	Tube wrap (51 cm or 20 inches)

Procedure

- Install a tube wrap (147 cm or 58 inches) to the cutting-unit connector cable.
- Install tube wraps (51 cm or 20 inches) to the 3 cutting-unit motor cables.

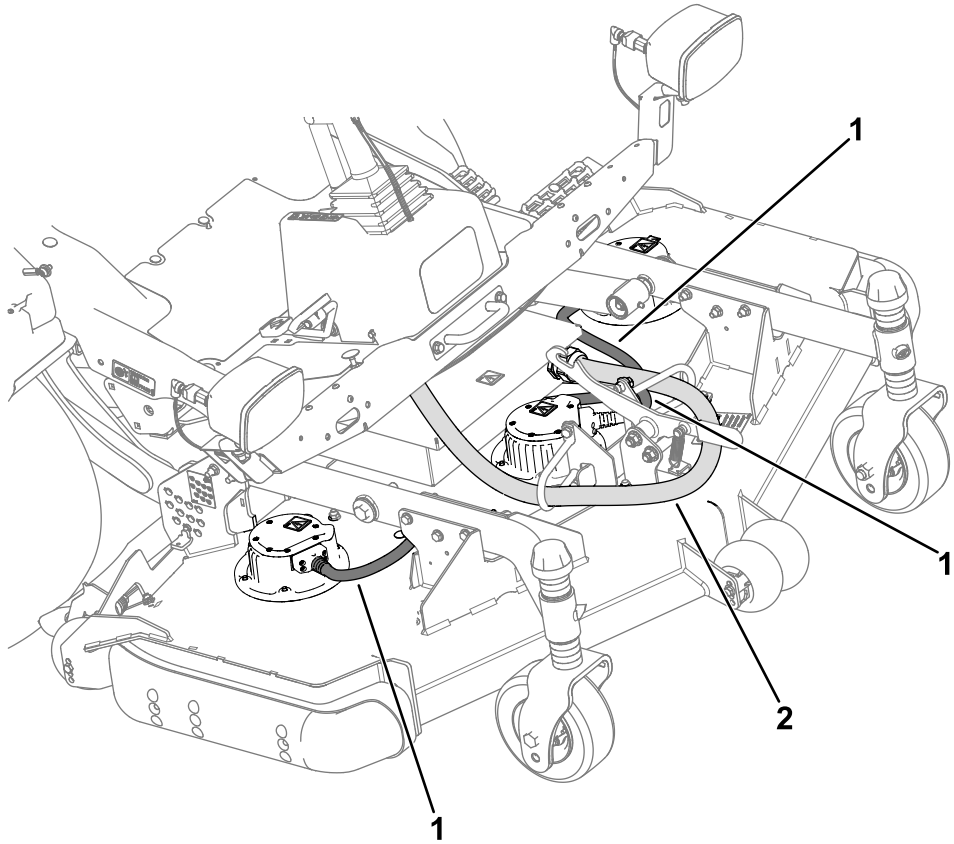

Figure 42

g461336

1. Tube wraps (51 cm or 20 inches)

2. Tube wrap (147 cm or 58 inches)

11

Completing the Installation

No Parts Required

Procedure

Turn the battery-disconnect switch to the ON position.

Notes:



Count on it.