



# **Groundsmaster 328-D**

## **2 & 4 Wheel Drive Traction Units**

Model No. 30626—230000001 and Up

Model No. 30627—230000001 and Up

Model No. 30630—230000001 and Up

Model No. 30631—230000001 and Up

**Operator's Manual**





## Warning



**The engine exhaust from this product contains chemicals known to the State of California to cause cancer, birth defects, or other reproductive harm.**

**Important** The engine in this product is not equipped with a spark arrester muffler. It is a violation of California Public Resource Code Section 4442 to use or operate this engine on any forest-covered, brush-covered, or grass-covered land as defined in CPRC 4126. Other states or federal areas may have similar laws.

# Contents

	Page
Contents .....	2
Introduction .....	3
Safety .....	4
Safety and Instruction Decals .....	8
Specifications .....	14
Setup .....	17
Loose Parts .....	17
Installing the Steering Cylinder .....	18
Installing the Tie Rod .....	18
Installing the Rear Bumper .....	18
Installing the Front and Rear Wheels .....	18
Installing the Steering Wheel .....	19
Removing the Battery from the Chassis .....	19
Installing the Seat .....	19
Installing the Seat Belt .....	21
Installing the Roll Bar .....	21
Pushing the Traction Unit Off of the Pallet .....	21
Activating and Charging the Battery .....	22
Installing the Battery in the Chassis .....	22
Installing the Ball Joint and Connecting the Lift Cylinder .....	22
Checking the Tire Pressure .....	23
Checking the Torque of the Front Wheel Nuts .....	23
Greasing the Traction Unit .....	23
Install Rear Weight .....	24
Before Operating .....	25
Hood Prop .....	25
Check Engine Oil .....	25
Filling the Fuel Tank .....	26
Check Cooling System .....	26
Checking the Hydraulic System Fluid .....	26
Checking the Rear Axle .....	27
Check Bidirectional Clutch Lubricant .....	27

	Page
Operation .....	28
Controls .....	28
Starting/Stopping Engine .....	30
Bleeding Fuel System .....	30
Checking the Interlock Switches .....	31
Pushing or Towing the Traction Unit .....	31
Operating Characteristics .....	32
Maintenance .....	33
Recommended Maintenance Schedule .....	33
Daily Maintenance Checklist .....	34
Lubricating the Machine .....	35
General Air Cleaner Maintenance .....	36
Servicing Air Cleaner .....	36
Cleaning the Radiator and Screen .....	37
Changing Engine Oil And Filter .....	37
Servicing Fuel System .....	38
Bleeding Air From Injectors .....	39
Cleaning Radiator And Screen .....	39
Changing Coolant In Cooling System .....	40
Servicing the Engine Belts .....	40
Adjusting Throttle .....	41
Adjusting Traction Control Rod .....	42
Adjusting Traction Pedal Friction Wheel .....	42
Adjusting the Traction Drive for Neutral .....	42
Adjusting the Traction Interlock Switch .....	43
Replacing the PTO Switch .....	43
Adjusting PTO Drive Belt Tension .....	44
Adjusting the Parking Brake Interlock Switch .....	44
Adjusting the Tilt Steering Control .....	44
Adjusting Rear Wheel Toe-in .....	45
Adjusting the Rear Wheel Bearings .....	45
Adjusting the Brakes .....	46
Replacing the Hydraulic Fluid Filter .....	47
Changing the Hydraulic System Fluid .....	47
Changing Rear Axle Lubricant .....	48
Changing Bidirectional Clutch Lubricant .....	49
Fuses .....	49
Servicing the Battery .....	49
Hydraulic Schematics .....	50
Electrical Schematics .....	52
Seasonal Storage .....	54
Traction Unit .....	54
Engine .....	54
The Toro General Commercial Products Warranty .....	56

# Introduction

Read this manual carefully to learn how to operate and maintain your product properly. The information in this manual can help you and others avoid injury and product damage. Although Toro designs and produces safe products, you are responsible for operating the product properly and safely.

Whenever you need service, genuine Toro parts, or additional information, contact an Authorized Service Dealer or Toro Customer Service and have the model and serial numbers of your product ready. Figure 1 illustrates the location of the model and serial numbers on the product.

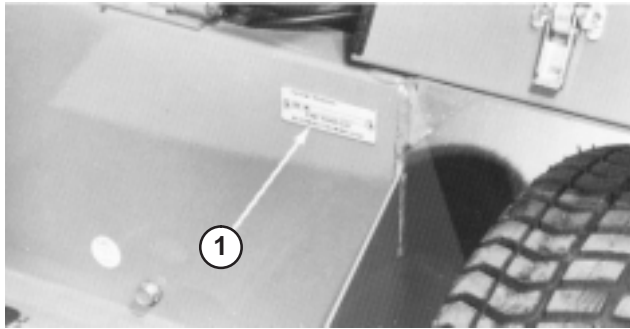

**Figure 1**

1. Location of the model and serial numbers

---

Write the product model and serial numbers in the space below:

<b>Model No.</b> _____
<b>Serial No.</b> _____

This manual identifies potential hazards and has special safety messages that help you and others avoid personal injury and even death. **Danger**, **Warning**, and **Caution** are signal words used to identify the level of hazard. However, regardless of the hazard, be extremely careful.

**Danger** signals an extreme hazard that *will* cause serious injury or death if you do not follow the recommended precautions.

**Warning** signals a hazard that *may* cause serious injury or death if you do not follow the recommended precautions.

**Caution** signals a hazard that may cause minor or moderate injury if you do not follow the recommended precautions.

This manual uses two other words to highlight information.

**Important** calls attention to special mechanical information and **Note**: emphasizes general information worthy of special attention.

# Safety

**Models 30630 and 30631 meet or exceed CEN standard EN 836:1997, ISO standard 5395:1990, and ANSI B71.4-1999 specifications in effect at the time of production, when weights are installed according to chart on page 24.**

**Models 30626 and 30627 meet or exceed the B71.4 1999 specifications of the American National Standards Institute, in effect at time of production, when weights are installed according to chart on page 24.**

**Note:** The addition of attachments made by other manufacturers that do not meet American National Standards Institute certification will cause noncompliance of this machine.

**Improper use or maintenance by the operator or owner can result in injury. To reduce the potential for injury, comply with these safety instructions and always pay attention to the safety alert  symbol, which means CAUTION, WARNING, or DANGER—“personal safety instruction.” Failure to comply with the instruction may result in personal injury or death.**

## Safe Operating Practices

The following instructions are from the CEN standard EN 836:1997, ISO standard 5395:1990, and ANSI B71.4-1999.

### Training

- Read the operator’s manual and other training material carefully. Be familiar with the controls, safety signs, and the proper use of the equipment.
- If the operator or mechanic can not read the language of is the owner’s responsibility to explain this material to them.
- Never allow children or people unfamiliar with these instructions to use or service the mower. Local regulations may restrict the age of the operator.
- Never mow while people, especially children, or pets are nearby.
- Keep in mind that the operator or user is responsible for accidents or hazards occurring to other people or their property.
- Do not carry passengers.
- All drivers and mechanics should seek and obtain professional and practical instruction. The owner is responsible for training the users. Such instruction should emphasize:

- the need for care and concentration when working with ride-on machines;
- control of a ride-on machine sliding on a slope will not be regained by the application of the brake. The main reasons for loss of control are:
  - insufficient wheel grip;
  - being driven too fast;
  - inadequate braking;
  - the type of machine is unsuitable for its task;
  - lack of awareness of the effect of ground conditions, especially slopes;
  - incorrect hitching and load distribution.
- The owner/user can prevent and is responsible for accidents or injuries occurring to himself or herself, other people, or property.

### Preparation

- While mowing, always wear substantial footwear, long trousers, hard hat, safety glasses, and ear protection. Long hair, loose clothing, or jewelry may get tangled in moving parts. Do not operate the equipment when barefoot or wearing open sandals.
- Thoroughly inspect the area where the equipment is to be used and remove all objects which may be thrown by the machine.
- **Warning**—Fuel is highly flammable. Take the following precautions:
  - Store fuel in containers specifically designed for this purpose.
  - Refuel outdoors only and do not smoke while refueling.
  - Add fuel before starting the engine. Never remove the cap of the fuel tank or add fuel while the engine is running or when the engine is hot.
  - If fuel is spilled, do not attempt to start the engine but move the machine away from the area of spillage and avoid creating any source of ignition until fuel vapors have dissipated.
  - Replace all fuel tanks and container caps securely.
- Replace faulty silencers/mufflers.
- Evaluate the terrain to determine what accessories and attachments are needed to properly and safely perform the job. Only use accessories and attachments approved by the manufacturer.

- Check that operator's presence controls, safety switches and shields are attached and functioning properly. Do not operate unless they are functioning properly.

## Operation

- Do not operate the engine in a confined space where dangerous carbon monoxide fumes can collect.
- Mow only in daylight or in good artificial light.
- Before attempting to start the engine, disengage all blade attachment clutches, shift into neutral, and engage the parking brake.
- Do not put hands or feet near or under rotating parts. Keep clear of the discharge opening at all times.
- Do not use on slopes of more than
  - 20° when mowing across a slope
  - 30° when mowing up or down a slope
- The maximum value of 50% of the limit of stability for EN836 is
  - 10° when mowing across a slope
  - 15° when mowing up or down a slope
- Remember there is no such thing as a safe slope. Travel on grass slopes requires particular care. To guard against overturning:
  - do not stop or start suddenly when going up or downhill;
  - engage clutch slowly, always keep machine in gear, especially when travelling downhill;
  - machine speeds should be kept low on slopes and during tight turns;
  - stay alert for humps and hollows and other hidden hazards;
  - never mow across the face of the slope, unless the mower is designed for this purpose.
- Stay alert for holes in the terrain and other hidden hazards.
- Use care when pulling loads or using heavy equipment.
  - Use only approved drawbar hitch points.
  - Limit loads to those you can safely control.
  - Do not turn sharply. Use care when reversing.
  - Use counterweight(s) or wheel weights when suggested in the operator's manual.
- Watch out for traffic when crossing or near roadways.
- Stop the blades rotating before crossing surfaces other than grass.
- When using any attachments, never direct discharge of material toward bystanders nor allow anyone near the machine while in operation.
- Never operate the machine with damaged guards, shields, or without safety protective devices in place. Be sure all interlocks are attached, adjusted properly, and functioning properly.
- Do not change the engine governor settings or overspeed the engine. Operating the engine at excessive speed may increase the hazard of personal injury.
- Before leaving the operator's position:
  - stop on level ground;
  - disengage the power take-off and lower the attachments;
  - change into neutral and set the parking brake;
  - stop the engine and remove the key.
- Disengage drive to attachments when transporting or not in use.
- Stop the engine and disengage drive to attachment
  - before refuelling;
  - before removing the grass catcher/catchers;
  - before making height adjustment unless adjustment can be made from the operator's position.
  - before clearing blockages;
  - before checking, cleaning or working on the mower;
  - after striking a foreign object or if an abnormal vibration occurs. Inspect the mower for damage and make repairs before restarting and operating the equipment.
- Reduce the throttle setting during engine run-out and, if the engine is provided with a shut-off valve, turn the fuel off at the conclusion of mowing.
- Keep hands and feet away from the cutting units.
- Look behind and down before backing up to be sure of a clear path.
- Slow down and use caution when making turns and crossing roads and sidewalks. Stop cylinders/reels if not mowing.
- Be aware of the mower discharge direction and do not point it at anyone.
- Do not operate the mower under the influence of alcohol or drugs
- Use care when loading or unloading the machine into a trailer or truck
- Use care when approaching blind corners, shrubs, trees, or other objects that may obscure vision.

## Maintenance and Storage



- Keep all nuts, bolts and screws tight to be sure the equipment is in safe working condition.
- Never store the equipment with fuel in the tank inside a building where fumes may reach an open flame or spark.
- Allow the engine to cool before storing in any enclosure.
- To reduce the fire hazard, keep the engine, silencer/muffler, battery compartment and fuel storage area free of grass, leaves, or excessive grease.
- Check the grass catcher frequently for wear or deterioration.
- Keep all parts in good working condition and all hardware and hydraulic fittings tightened. Replace all worn or damaged parts and decals.
- If the fuel tank has to be drained, do this outdoors.
- Be careful during adjustment of the machine to prevent entrapment of the fingers between moving blades and fixed parts of the machine.
- On multi-spindle mowers, take care as rotating one blade can cause other blades to rotate.
- Disengage drives, lower the cutting units, set parking brake, stop engine and remove key and disconnect spark plug wire. Wait for all movement to stop before adjusting, cleaning or repairing.
- Clean grass and debris from cutting units, drives, silencers/mufflers, and engine to help prevent fires. Clean up oil or fuel spillage.
- Use jack stands to support components when required.
- Carefully release pressure from components with stored energy.
- Disconnect battery and remove spark plug wire before making any repairs. Disconnect the negative terminal first and the positive last. Reconnect positive first and negative last.
- Use care when checking the cylinders/reels. Wear gloves and use caution when servicing them.
- Keep hands and feet away from moving parts. If possible, do not make adjustments with the engine running.
- Charge batteries in an open well ventilated area, away from spark and flames. Unplug charger before connecting or disconnecting from battery. Wear protective clothing and use insulated tools.

## Toro Riding Mower Safety

The following list contains safety information specific to Toro products or other safety information that you must know that is not included in the CEN, ISO, or ANSI standard.

This product is capable of amputating hands and feet and throwing objects. Always follow all safety instructions to avoid serious injury or death.

Use of this product for purposes other than its intended use could prove dangerous to user and bystanders.

 <b>Warning</b> 
<b>Engine exhaust contains carbon monoxide, which is an odorless, deadly poison that can kill you.</b>
<b>Do not run engine indoors or in an enclosed area.</b>

- Know how to stop the engine quickly.
- Do not operate the machine while wearing tennis shoes or sneakers.
- Wearing safety shoes and long pants is advisable and required by some local ordinances and insurance regulations.
- Handle fuel carefully. Wipe up any spills.
- Check the safety interlock switches daily for proper operation. If a switch should fail, replace the switch before operating the machine. After every two years, replace all interlock switches in the safety system, whether they are working properly or not.
- Before starting the engine, sit on the seat.
- Using the machine demands attention. To prevent loss of control:
  - Do not drive close to sand traps, ditches, creeks, or other hazards.
  - Reduce speed when making sharp turns. Avoid sudden stops and starts.
  - When near or crossing roads, always yield the right-of-way.
  - Apply the service brakes when going downhill to keep forward speed slow and to maintain control of the machine.
- Raise the cutting units when driving from one work area to another.
- Do not touch the engine, silencer/muffler, or exhaust pipe while the engine is running or soon after it has stopped because these areas could be hot enough to cause burns.

- If the engine stalls or loses headway and cannot make it to the top of a slope, do not turn the machine around. Always back slowly, straight down the slope.
- When a person or pet appears unexpectedly in or near the mowing area, **stop mowing**. Careless operation, combined with terrain angles, ricochets, or improperly positioned guards can lead to thrown object injuries. Do not resume mowing until the area is cleared.

## Maintenance and Storage

- Make sure all hydraulic line connectors are tight and all hydraulic hoses and lines are in good condition before applying pressure to the system.
- Keep your body and hands away from pin hole leaks or nozzles that eject hydraulic fluid under high pressure. Use paper or cardboard, not your hands, to search for leaks. Hydraulic fluid escaping under pressure can have sufficient force to penetrate the skin and cause serious injury. Seek immediate medical attention if fluid is injected into skin.
- Before disconnecting or performing any work on the hydraulic system, all pressure in the system must be relieved by stopping the engine and lowering the cutting units and attachments to the ground.
- Check all fuel lines for tightness and wear on a regular basis. Tighten or repair them as needed.
- If the engine must be running to perform a maintenance adjustment, keep hands, feet, clothing, and any parts of the body away from the cutting units, attachments, and any moving parts, especially the screen at the side of the engine. Keep everyone away.
- To ensure safety and accuracy, have an Authorized Toro Distributor check the maximum engine speed with a tachometer. Maximum governed engine speed should be 2900 RPM.
- If major repairs are ever needed or if assistance is desired, contact an Authorized Toro Distributor.
- Use only Toro-approved attachments and replacement parts. The warranty may be voided if used with unapproved attachments.

## Sound Power Level

This unit has a guaranteed sound power level of 105 dBA, based on measurements of identical machines per Directive 2000/14/EC and amendments.

## Sound Pressure Level

This unit has an equivalent continuous A-weighted sound pressure level at the operator ear of 89 dBA based on measurements of identical machines per Directive 98/37/EC and amendments

## Vibration Level

This unit does not exceed a vibration level of 2.5 m/s<sup>2</sup> at the hands based on measurements of identical machines per ISO 5349 procedures.

This unit does not exceed a vibration level of 0.5 m/s<sup>2</sup> at the posterior based on measurements of identical machines per ISO 2631 procedures.



# Safety and Instruction Decals



Safety decals and instructions are easily visible to the operator and are located near any area of potential danger. Replace any decal that is damaged or lost.

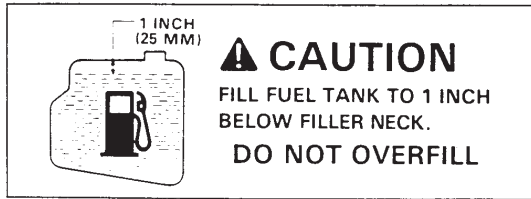

**27-7310**  
**(Models 30626 & 30627)**



**93-7275**  
**(Models 30630 & 30631)**

1. Read the operator's manual for further instructions.
2. Do not use starting fluid.

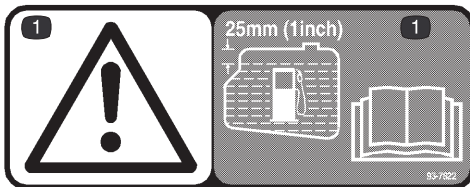

**93-7822**  
**(Models 30630 & 30631)**

1. Caution—fill fuel tank to 1 in. (25 mm) below filler neck. Read the operator's manual for further instructions.



**52-1321**  
**(Models 30626 & 30627)**



**93-6680**  
**(Models 30630 & 30631)**

1. Diesel fuel



**83-9150**  
**(Models 30626 & 30627)**



**93-6686**

1. Hydraulic oil
2. Read the *Operator's Manual*.



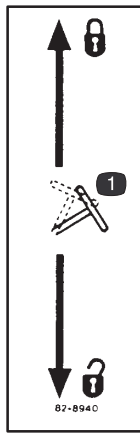

82-8940

1. Locks and unlocks the steering column

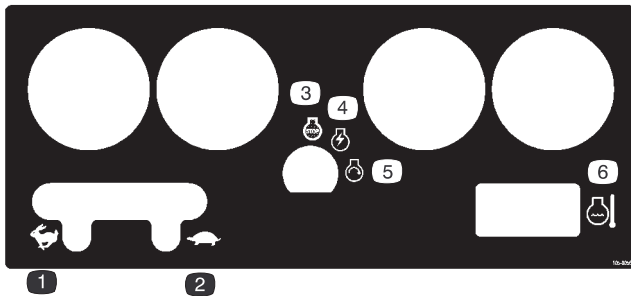

105-0056

- |                |                 |
|----------------|-----------------|
| 1. Fast        | 4. Engine run   |
| 2. Slow        | 5. Engine start |
| 3. Engine stop | 6. Temperature  |



27-7320  
(Models 30626 & 30627)

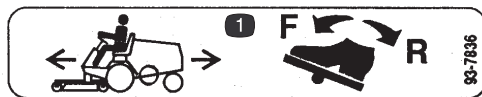

93-7836

1. To move the traction unit forward or backward, depress the traction pedal.



55-4300  
(Models 30626 & 30627)



93-6696  
(Models 30630 & 30631)

1. Warning—spring loaded mechanism. Read the operator's manual for further instructions.



77-3100  
(Models 30626 & 30627)

1. Fan blades can cause injury—stay away from moving parts.

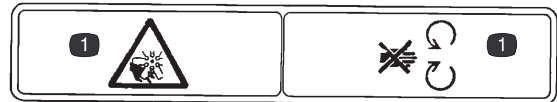

93-7272  
(Model 30630 & 30631)

1. Fan blades can cause injury—stay away from moving parts.



67-1720  
(Models 30626 & 30627)



**93-7830**  
**(Models 30630 & 30631)**

1. Caution—read the operator's manual for further instructions.
2. Wheel torque specifications

**STARTING INSTRUCTIONS**  
 (SEE OPERATOR'S MANUAL)

1. DISENGAGE POWER TAKE-OFF.
2. PLACE TRACTION DRIVE IN NEUTRAL POSITION.
3. DEPRESS BRAKE PEDAL.
4. SET THROTTLE CONTROL - HALF OPEN.
5. TURN KEY TO RUN POSITION AND WAIT UNTIL GLOW LIGHT TURNS OFF.
6. TURN KEY TO START POSITION. TO STOP, TURN KEY TO OFF POSITION AND REMOVE KEY.

**IMPORTANT:**  
 ENGINE WILL SHUT OFF AUTOMATICALLY DUE TO HIGH ENGINE TEMPERATURE. WHEN THIS HAPPENS:

1. ALLOW ENGINE TO COOL.
2. CLEAN DEBRIS FROM FRONT OF RADIATOR.
3. CHECK COOLANT LEVEL.

**CAUTION**  
 COOLANT UNDER PRESSURE. USE CAUTION WHEN REMOVING RADIATOR CAP TO PREVENT BURNS.

4. DEPRESS HIGH TEMPERATURE RESET ON DASH.
5. RESTART ACCORDING TO STARTING INSTRUCTIONS.

READ AND UNDERSTAND OPERATOR'S MANUAL BEFORE OPERATING THIS MACHINE. REPLACEMENT MANUAL AVAILABLE BY SENDING COMPLETE MODEL NUMBER TO: THE TORO CO., 8111 LYNDALE AVE. S., BLOOMINGTON, MN 55420-1196. 105-2531

**105-2531**  
**(Models 30626 & 30627)**

**105-2532**

**105-2532**  
**(Models 30630 & 30631)**

1. To start the engine, disengage the Power Take Off, place the traction drive in neutral, depress the brake pedal, set the throttle control half open, turn the ignition key to the run position. When the glow light turns off, turn the key to the start position. Read the operator's manual for further instructions.
2. Warning—when engine temperature is too high, engine will shut off. Depress high temperature reset before restarting engine.
3. Warning—coolant is under pressure and could cause burns. Keep a safe distance away.



**82-8930**  
**(Model 30626 & 30627)**

1. Read the operator's manual for further instructions.



**93-7831**

1. Parking brake—read the operator's manual for further instructions.

**WARNING**

**TO REDUCE THE POSSIBILITY OF ACCIDENTS, INJURY OR DEATH: CHECK PERFORMANCE OF ALL INTERLOCK SWITCHES DAILY. SEE OPERATOR'S MANUAL FOR INSTRUCTIONS. DO NOT DEFEAT INTERLOCK SYSTEM. IT IS FOR YOUR PROTECTION.**

67-1710

**67-1710**  
**(Model s 30626 & 30627)**

**82-8970**  
**(Models 30626 & 30627)**

1. Fill coolant to within 1 in. (25 mm) of the top of the tank.
2. Read the operator's manual for further instructions.

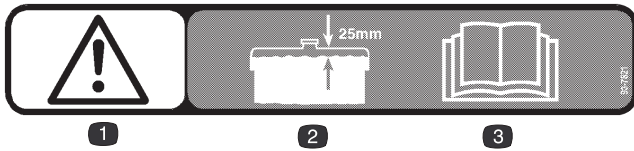

93-7821

(Models 30630 & 30631)

1. Caution
2. Fill coolant to within 1 in. (25 mm) of the top of the tank.
3. Read the operator's manual for further instructions.

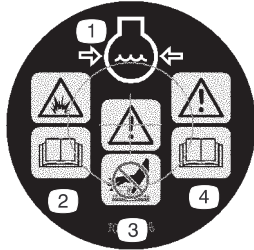

106-5976

- |   |  |
|---|--|
| 1. Engine coolant under pressure                        | 3. Warning—do not touch the hot surface.       |
| 2. Explosion hazard—read the <i>Operator's Manual</i> . | 4. Warning—read the <i>Operator's Manual</i> . |



27-7290

(Models 30626 & 30627)

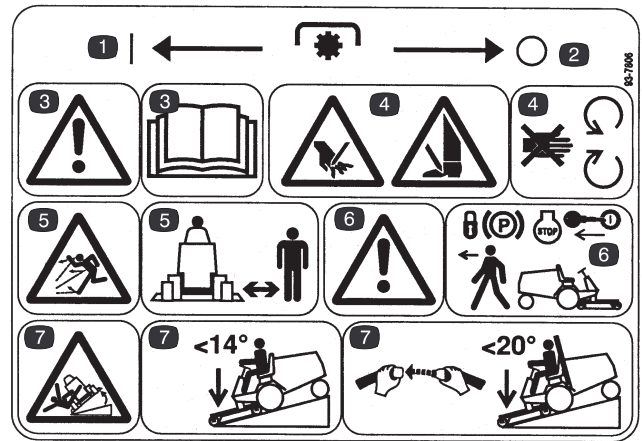

93-7806

(Models 30630 & 30631)

1. PTO on
2. PTO off
3. Warning—read the operator's manual.
4. Cutting hazard to hands or feet—stay away from rotating blades and moving parts.
5. Throw object hazard—keep bystanders away.
6. Warning—set the parking brake, stop the engine, and remove the key before leaving the operator's position.
7. Tipping hazard—when driving down slopes less than 14 degrees, lower the cutting unit to the ground. When driving down slopes less than 20 degrees, use the ROPS, fasten the seat belt, and lower the cutting unit to the ground.

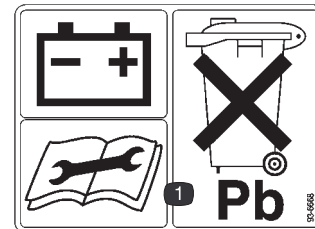

93-6668

(Models 30630 & 30631)

1. The battery contains lead. Do not throw it in the garbage.

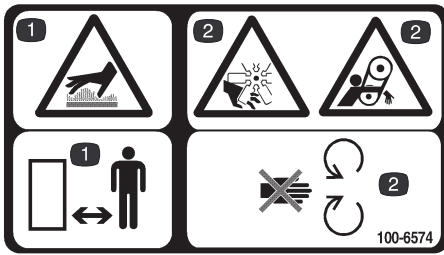

**100-6574**  
**(Models 30630 & 30631)**

1. Hot surface hazard—stay away.
2. Cutting/dismemberment hazard—stay away from moving parts.



**72-3700**  
**(Model 30627)**

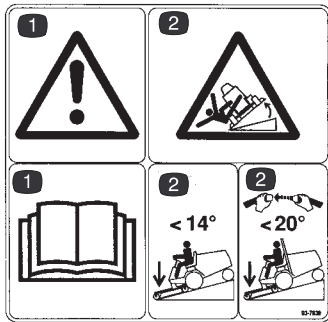

**93-7839**  
**(Model 30631)**

1. Danger—read the operator's manual.
2. Tipping hazard—when driving down slopes less than 14 degrees, lower the cutting unit to the ground. When driving down slopes less than 20 degrees, use the ROPS, fasten the seat belt, and lower the cutting unit to the ground.



**70-2560**  
**(Model 30627)**

1. Change the rear axle lubricant initially after first 50 operating hours, thereafter every 500 hours



**93-6697**  
**(Model 30631)**

1. Read operator manual
2. Change the rear axle lubricant initially after first 50 operating hours, thereafter every 500 hours



**67-5360**  
**(Models 30626 & 30627)**

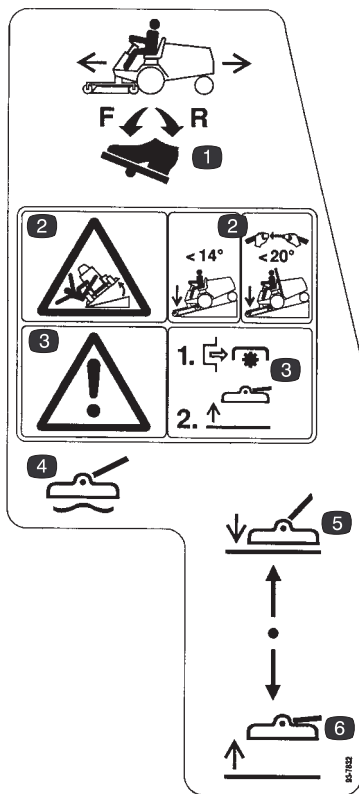

**93-7832  
(Models 30630 & 30631)**

1. To move the traction unit forward or backward, depress the traction pedal.
2. Tipping hazard—when driving down slopes less than 14 degrees, lower the cutting unit to the ground. When driving down slopes less than 20 degrees, use the ROPS, fasten the seat belt, and lower the cutting unit to the ground.
3. Warning—disengage the Power Take Off before raising the cutting unit.
4. Float cutting unit
5. Lower cutting unit
6. Raise cutting unit

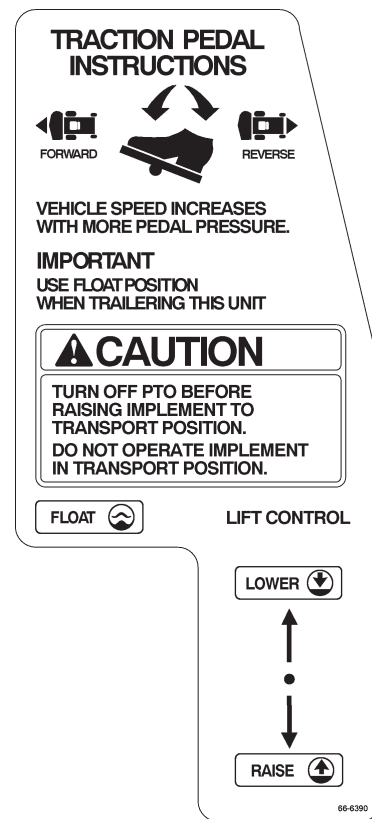

**66-6390  
(Models 30626 & 30627)**

# Specifications

**Note:** Specifications and design subject to change without notice.

## General Specifications

Engine	Kubota, three cylinder, 4 cycle liquid cooled diesel engine. 26 hp @ 3000. Engine governed to 3200–3250 rpm high idle, no load.
Air Cleaner	Heavy duty, remote mounted
Muffler	Volume equal to approximately five times engine displacement for excellent silencing.
Cooling System	Radiator has tube and fin construction with hydraulic oil cooler in lower tank. Capacity of cooling system is approximately 6 quarts (5.7 l) of a 50% mixture of permanent, ethylene glycol anti-freeze and water.
Electrical	12 volt battery has 630 amp., cold cranking performance at 0° F (–18° C). Fuse block located under the control panel. Starter relay interlock circuit for maximum current hold-in of starter solenoid in low voltage conditions
Fuel System	Fuel tank capacity is approximately 6-1/2 gal. (25 l). 12 volt, electric fuel pump . Fuel filter/water separator with replaceable cartridge is mounted on frame.
Front Axle	The heavy duty Dana GT 20 axle has reduction of 20:9:1. Axle has automotive type differential, bevel gear pinion and ring gear with spur gear reduction from transmission. All axle components are mounted in tapered roller bearings.
Rear Axle (Models 30627 & 30631)	The rear axle is mechanically driven from the front axle by a universal shaft. Axle has a bidirectional – overrunning clutch in rear driveshaft. When lubricating rear axle, use SAE 80W-90 gear lube, API GL-5. Lubricant capacity is approximately 2.2 qt. (2.1 L).
Transmission	The in-line hydrostatic transmission is mounted directly to the front axle and is driven by flexible drive couplings. Operating pressure is 500 to 3000 psi (3447 to 20685 kPa) and normal charge pressure is 70 to 150 psi (453 to 1034 kPa). Implement relief valve setting is 700 to 900 psi (4826 to 6205 kPa). Displacement is 0.913 cubic inch (15 cm <sup>3</sup> ) per revolution, and transmission is controlled by foot-actuated pedal. Front axle is the hydraulic fluid reservoir, and its capacity is 5 quarts (4.7 l). The 25 micron hydraulic filter is a screw on replaceable type. For replacement filters, order Toro Part No. 23-9740.
Ground Speed	Speed is infinitely variable from 0 to 9.5 MPH (0 to 15 km/h) forward or reverse.
Tires	Two rear tires are 18 x 6.50-8, 4-ply, extra traction tread, on demountable, drop center wheels. The two front tires are 23 x 8.50-12, extra traction tread, 4-ply rating, on demountable, drop center wheels. Recommended air pressure for both the front and rear tires is 21 psi (145 kPa).
Brakes	Brakes controlled by 3 pedals. Two are for steering assist. Are individually controlled by left foot. Third pedal operates both brakes; is controlled by either foot. Parking brake latch provided for third pedal. Pedals are connected to brakes by multi-stranded cable and conduit.
Steering	The 13 inch (33 cm) steering wheel is mounted on a steering valve consisting of a control valve and metering section which regulates pressure and meters flow to the steering cylinder. Minimum turning radius is 18 in. from center of turn to closest side of drive wheel; however, zero turning radius results when individual wheel brakes are used. Steering wheel adjustable fore and aft for operator comfort.
Main Frame	Frame is welded, formed 11 ga. steel, reinforced with square and rectangular tubing.

## General Specifications (continued)

Interlock Switches	PTO switch—shuts engine off when PTO is engaged with no operator in seat. Traction switch—shuts engine off when traction pedal is engaged with no operator in seat. Seat switch—shuts engine off if operator leaves seat without disengaging PTO and/or traction pedal. Engine will not start if PTO or traction pedal is engaged. Brake switch—shuts engine off when PTO or traction pedal is engaged with parking brake set.
Instrument Panel and Control	Hour meter, fuel gauge, ignition switch, oil pressure warning light, charge indicator, engine coolant temperature warning light, temperature gauge, temperature override switch, glow plug indicator light and throttle control are on instrument panel. Hand operated PTO lever is located to right of the seat. Traction pedal for traction operation at right of steering column.
PTO Drive	Shaft is driven by a tight-slack double “A” section, torque team V-belt directly from output shaft of engine. Shaft is clutched by pivoting the shaft support with a spring loaded, over center, hand operated lever. PTO speed 1810 RPM @ 3200 RPM engine speed. Connection to implement is with high quality, needle bearing universal joint with slip joint.
Implement Lift	Cutting unit or implement is lifted by hydraulic cylinder that has 2-1/2 in. (64 mm) bore and 3-1/4 in. (82 mm) stroke.

## Dimensions and Weights (approx.)

Width (measured from outside of front tires)	46 in. (117 cm)
Length	91 in. (231 cm)
Height	50 in. (127 cm)
Height w/ROPS	78.5 in. (199 cm)
Dry Weight – 2 Wheel Drive w cutter deck	1650 lb. (743 kg)
Dry Weight – 4 Wheel Drive	2065 lb. (929 kg)
Wheel Base	49 in. (124 cm)



## Optional Equipment

72" Side Discharge Cutting Unit	Model No. 30722 Model No. 30722TE	Quick Attach (for Guardian 72" Recycler Cutting Unit, Model No. 30716)	Model No. 30729
72" Rear Discharge Cutting Unit	Model No. 30710 Model No. 30710TE	Quick Attach (for 72" Side Discharge Cutting Unit, Model No. 30722, 72" Rear Discharge Cutting Unit, Model No. 30710 and Rotary Broom, Model No. 30743)	Model No. 30719
72" Flex Deck Cutting Unit	Model No. 30799	Tire Chains (front) (set of 2)	Part No. 11-0390
Guardian 72" Recycler Cutting Unit	Model No. 30716	Tire Chains (rear) (set of 2) (Models 30627 & 30631 only)	Part No. 76-1840
Cushion Seat	Model No. 30623	Wheel Weight Kit (set of 2)	Part No. 11-0440
Deluxe Suspension Seat Kit (requires Model No. 30628)	Model No. 30625	Rear Weight Kit (set of 2)	Part No. 24-5780
Seat Adapter Kit	Model No. 30628	Rear Weight Kit (set of 1)	Part No. 24-5790
Armrest Kit (for seat models 30623 & 30625)	Model No. 30707	4-Ply Wide Tire w/Rim, 23 x 10.5 x 12 (2 required; will not fit with 72" Rear Discharge Cutting Unit, Model No. 30710)	Part No. 62-7020
Speed Control Kit	Model No. 30677	6-Ply Wide Tire w/ Rim 23 x 10.5 x 12 (2 required; will not fit with 72" Rear Discharge Cutting Unit, Model No. 30710)	Part No. 69-9870
48 in. V-Plow (requires Model No. 30757)	Model No. 30750		
V-Plow Mounting Kit (w/o tire chains)	Model No. 30757		
Debris Blower	Model No. 30855	Jack Pad Kit	Part No. 106-4386
Spark Arrestor Screen	Part No. 75-6880		
Rotary Broom	Model No. 30743		
Quick Attach Receiver Kit (for traction unit)	Model No. 30711		

# Setup

**Note:** Determine the left and right sides of the machine from the normal operating position.

## Loose Parts

**Note:** Use the chart below to verify that all parts have been shipped.

Description	Qty.	Use
Screw, M10 x 30 mm	4	Mounting steering cylinder to rear axle. (Models 30627 & 30631 only)
Washer	4	
Tie rod	1	Mount to steering arms. (Models 30627 & 30631 only)
Bumper	1	Mount to axle support. (Models 30627 & 30631 only)
Flange head screw, 5/16 x 1 in.	1	Secure steering hoses to bumper. (Models 30627 & 30631 only)
Locknut 5/16 in.	1	
Rear wheel	2	Mounting rear steering wheels (Metric nuts)
Front wheel	2	Mounting front wheels (English nuts)
Steering wheel	1	Installing the steering wheel
Foam seal	1	
Nut	1	
Screw	1	
Cap	1	
Manual tube (shipped in tool box)	1	Holding the operator's manual. Install on right underside of seat.
R-clamp	2	
Seat belt	1	Installing the seat belts (Models 30627 & 30631 only)
Bolt, 7/16 x 1 in.	2	
Lock washer, 7/16 in.	2	
Roll Bar (ROPS)	1	Installing the roll bar (Models 30627 & 30631 only)
Bolt, 3/4 x 3-1/2 in.	4	
Lock washer, 3/4 in.	4	
Nut, 3/4 in.	4	
Right-hand ball joint (shipped in tool box)	1	Install ball joint (implement installation) and connect lift cylinder
Hydraulic oil filter	1	Change after 10 hours
Parts catalog	1	
Operator's Manual (traction unit) Model 30627	2	Read before operating the machine.
Operator's Manual (traction unit) Model 30631	1	Read before operating the machine.
Operator Video	1	Watch before operating the machine.
Registration card	1	Fill out and return to Toro.

**Note:** Some models may have already been set-up at factory.

## Installing the Steering Cylinder (Models 30627 & 30631 only)

1. Remove screw and R-clamp securing steering cylinder to packaging. Retain R-clamp for future installation.
2. Mount cylinder support bracket to rear of axle with 4 screws (M10 x 30) screws and washers (Fig. 2). Apply Loctite 242, or equivalent, and torque screws to 34-42 ft.-lb. (46-56 N·m).

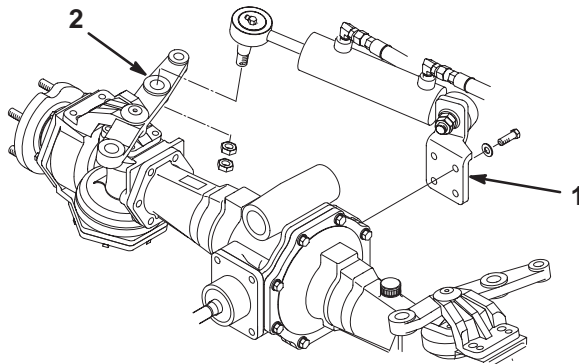

**Figure 2**

1. Cylinder support bracket
2. Steering arm

3. Remove jam nuts from ball joint end of steering cylinder. Insert ball joint end into center hole of axle steering arm. Insert the ball joint from the top of the steering arm.
4. Secure ball joint end to steering arm with a jam nut (Fig. 2) and torque it to 70-90 ft.-lb. (94-122 N·m). Install a second jam nut and torque it to 70-90 ft.-lb. (94-122 N·m).

## Installing the Tie Rod (Models 30627 & 30631 only)

1. Remove jam nuts from ball joint ends of tie rod. Insert ball joint ends into rear hole of each axle steering arm. Insert ball joints from bottom of each steering arm (Fig. 3).
2. Secure ball joint ends to steering arms with a jam nut and torque it to 40-60 ft.-lb. (54-81 N·m). Install a second jam nut and torque it to 40-60 ft.-lb. (54-81 N·m).

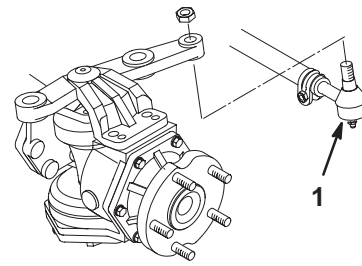
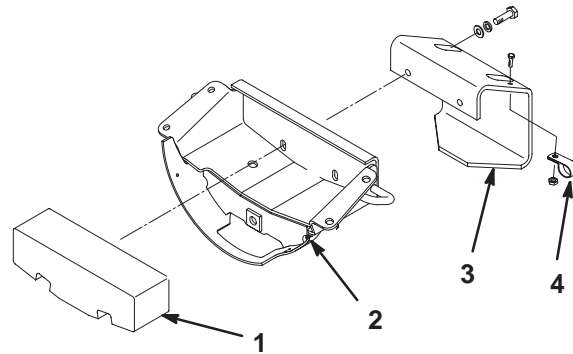

**Figure 3**

1. Tie rod

## Installing the Rear Bumper (Models 30627 & 30631 only)

1. Remove 2 capscrews (1/2 x 3/4 in.), lock washers, and flat washers securing rear weight to axle support (Fig. 4).



**Figure 4**

1. Rear weight
2. Axle support
3. Bumper
4. R-clamp

2. Using capscrews, lock washers and flat washers previously removed, mount bumper and rear weight to axle support.
3. Using R-clamp removed in step 1, secure steering hoses to top of bumper with a flange head screw (5/16 x 1 in.) and locknut supplied, in loose parts.

## Installing the Front and Rear Wheels

1. Remove and discard fasteners securing wheels to packaging.
2. Remove wheel nuts from studs on axles.

**Note:** Front wheel nuts are English and rear wheel nuts are metric.

3. Mount wheels and torque mounting nuts to 45-55 ft.-lb. (61-75 N·m).

## Installing the Steering Wheel

1. Move rear wheels so they point straight ahead.
2. Remove jam nut from steering shaft. Slide foam seal and steering wheel onto steering shaft (Fig. 5).

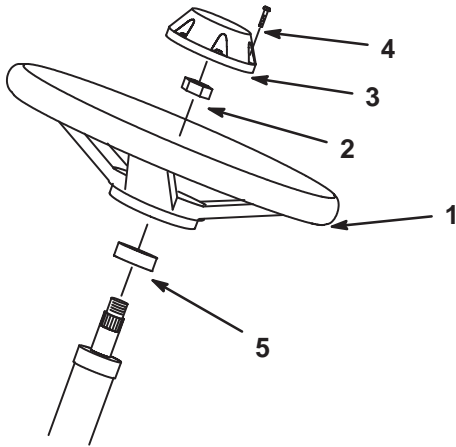

**Figure 5**

- |                   |              |
|-------------------|--------------|
| 1. Steering wheel | 4. Screw     |
| 2. Jam nut        | 5. Foam seal |
| 3. Cap            |              |

3. Secure steering wheel to shaft with jam nut and tighten it to 10–15 ft.-lb.
4. Install cap to steering wheel with screw (Fig. 5).

## Removing the Battery from the Chassis

1. Release the two latches holding instrument cover in place. Carefully remove instrument cover to expose the battery.
2. Remove two wing nuts and hold down strap that secures battery (Fig. 6). Lift battery out of chassis. Keep wing nuts and hold down strap in safe place for later use.

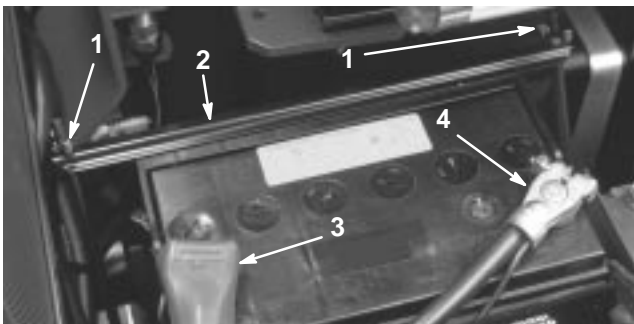

**Figure 6**

- |                    |                      |
|--------------------|----------------------|
| 1. Wing nuts       | 3. Positive terminal |
| 2. Hold down strap | 4. Negative terminal |

## Installing the Seat

The machine is shipped without the seat assembly. Either optional Seat Kit, Model No. 30623 or 30625 must be installed.

### Seat Kit, Model No. 30623, Standard Seat

1. Loosely secure (2) R-clamps to right side of seat bottom with 2 capscrews and flat washers supplied in kit (Fig. 7). Install manual tube into R-clamps and tighten capscrews (Fig. 7).

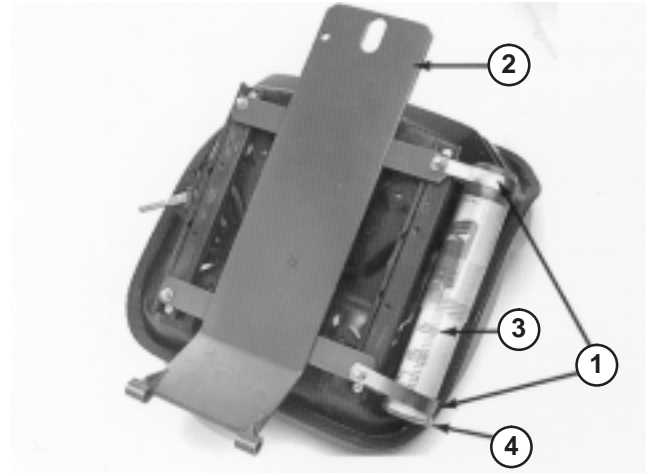

**Figure 7**

- |                 |                |
|-----------------|----------------|
| 1. R-clamps     | 3. Manual tube |
| 2. Seat support | 4. Cap         |

2. Mount seat pivot bracket to frame with 2 flange screws supplied in kit (Fig. 8)

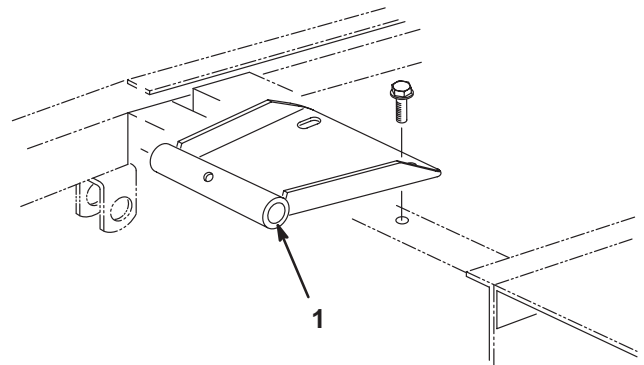

**Figure 8**

1. Seat pivot bracket

3. Mount seat and seat support to seat pivot bracket with pivot shaft and roll pin (Fig. 9).

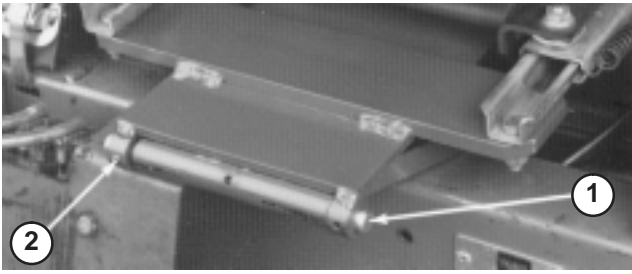

**Figure 9**

- 1. Pivot shaft
- 2. Roll pin

- 4. Hold seat up with seat support rod (Fig. 10).
- 5. Plug wire harness connector into seat switch connector on bottom of seat.

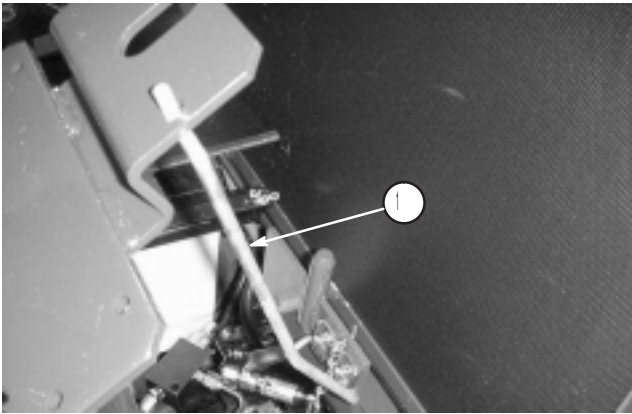

**Figure 10**

- 1. Seat support rod

- 6. Disengage seat support rod and pivot downward. Pivot seat down and push lynch pin through seat latch stud. Flip wire end of pin over latch stud (Fig. 11).

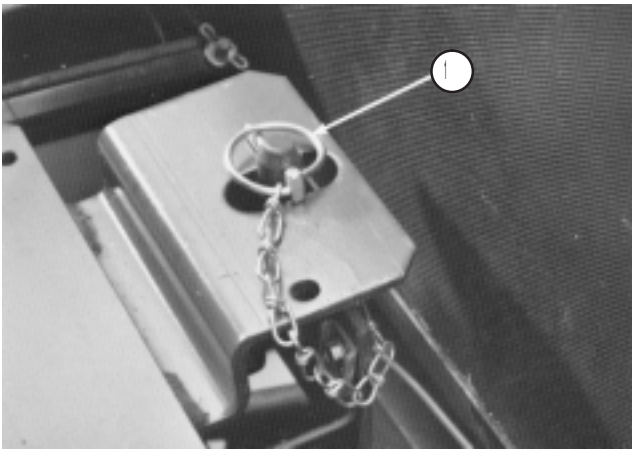

**Figure 11**

- 1. Lynch pin

- 7. Slide seat completely forward and backward to ensure proper operation and that seat switch wires and connectors are not pinched or do no contact any moving parts.

**Seat Kit, Model No. 30625, Deluxe Seat with Model No. 30628 Seat Adapter Kit**

- 1. Mount seat suspension assembly to 4 capscrews on seat bottom and secure with 4 lock washers, flat washers, and nuts (Fig. 12).

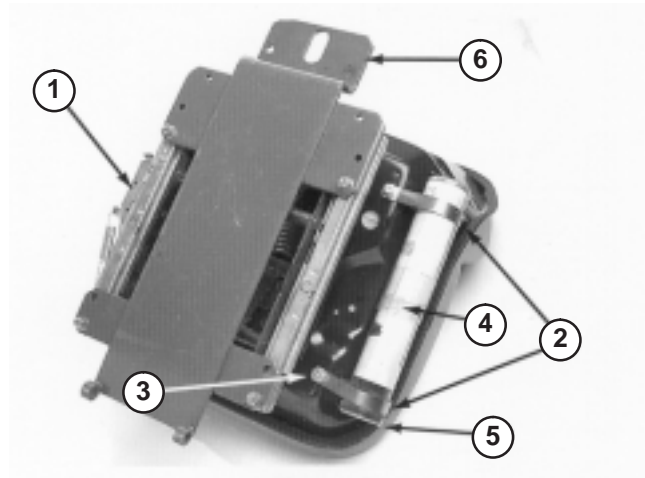

**Figure 12**

- 1. Seat suspension assembly
- 2. R-clamps
- 3. Lock washer, flat washer, and nut
- 4. Manual tube
- 5. Cap
- 6. Seat support

- 2. Loosely secure 2 R-clamps to right side of seat bottom with 2 capscrews and flat washers supplied in kit (Fig. 12). Install manual tube into R-clamps and tighten capscrews (Fig. 12).
- 3. Mount seat support over four threaded studs at the bottom of seat suspension assembly and secure in place with flangenuts (Fig. 12).
- 4. Mount seat pivot bracket to frame with (2) flange screws supplied in kit (Fig. 8)
- 5. Mount seat and seat support to seat pivot bracket with pivot shaft and roll pin (Fig. 9).
- 6. Hold seat up with seat support rod (Fig. 10).
- 7. Route seat switch harness through holes in seat support and seat suspension (Fig. 13). Plug wire harness connector into seat switch connector on bottom of seat.

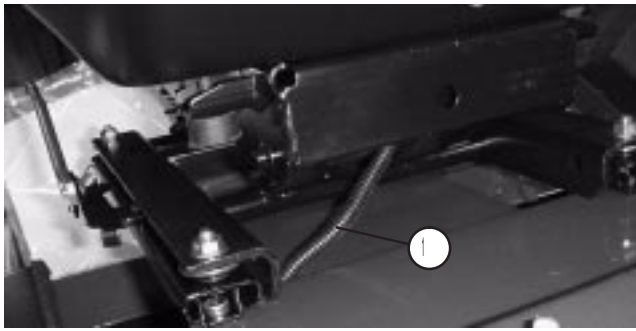

**Figure 13**

1. Seat switch wire harness

8. Disengage seat support rod and pivot downward. Pivot seat down and push lynch pin through seat latch stud. Flip wire end of pin over latch stud (Fig. 11).
9. Slide seat completely forward and backward to ensure proper operation and that seat switch wires and connectors are not pinched or do no contact any moving parts.

## Installing the Seat Belt (Models 30627 & 30631 only)

Install seat belt to holes in back of seat with 2 bolts (7/16 x 1 in.) and lock washers (Fig. 14). Tighten securely.

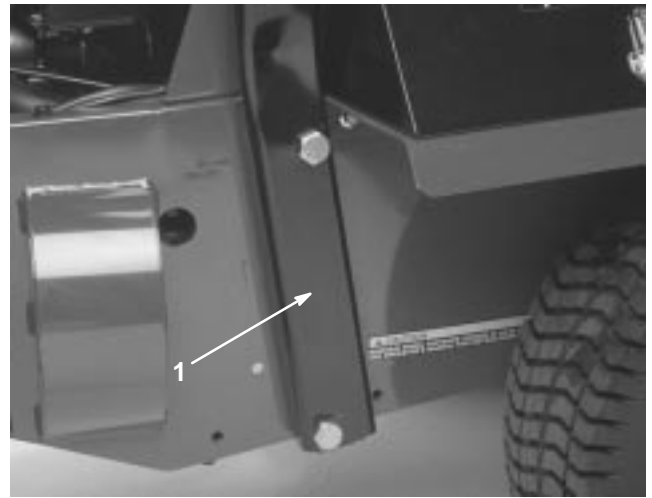

**Figure 14**

1. Seat belt
2. Bolt and lock washer

## Installing the Roll Bar (Models 30627 & 30631 only)

1. Lower roll bar onto frame, aligning mounting holes as shown in Figure 15.
2. Secure roll bar to frame with 4 bolts (3/4 x 3-1/2 in.), lock washers, and nuts (Fig. 15). Tighten securely.

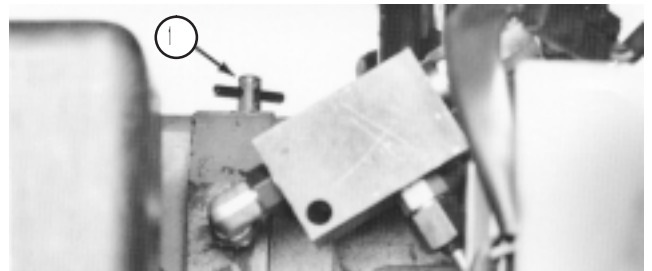

**Figure 15**

1. Roll bar

## Pushing the Traction Unit Off of the Pallet

1. Reach in and rotate bypass valve on transmission (Fig. 16) counterclockwise 1/2 to 1 turn. Opening the valve opens an internal passage in the pump, thereby bypassing transmission oil. Because fluid is bypassed, the machine can be pushed without damaging the transmission.



**Figure 16**

1. Bypass valve
2. Lift machine over shipping braces and push machine off pallet.
3. Close bypass valve by rotating it clockwise until it is securely seated. Do not exceed 5 to 8 ft.-lb. (7 to 11 N-m). Do not start engine when valve is open.



## Activating and Charging the Battery

1. If battery is not filled with electrolyte or charged, bulk electrolyte with 1.280 specific gravity @ 77° F (25° C) must be purchased from a local battery supply outlet.

**Danger**

Battery electrolyte contains sulfuric acid which is a deadly poison and causes severe burns.

- Do not drink electrolyte and avoid contact with skin, eyes or clothing. Wear safety glasses to shield your eyes and rubber gloves to protect your hands.
- Fill the battery where clean water is always available for flushing the skin.

2. Remove filler caps from battery and slowly fill each cell until electrolyte is just above the plates. Install filler caps.
3. Connect a 3 to 4 amp. battery charger to the battery posts. Charge the battery at a rate of 3 to 4 amperes for 4 to 8 hours.
4. When battery is fully charged, disconnect charger from electrical outlet and battery posts.
5. Remove filler caps and slowly add electrolyte to each cell until level is up to fill ring. Install fill caps.

## Installing the Battery in the Chassis

**Warning**

Battery terminals or metal tools could short against metal machine components causing sparks. Sparks can cause the battery gasses to explode, resulting in personal injury.

- When removing or installing the battery, do not allow the battery terminals to touch any metal parts of the machine.
- Do not allow metal tools to short between the battery terminals and metal parts of the machine.

1. Install battery and secure with hold down strap and wing nuts (Fig. 6). Remove tape over ends of each cable.

2. Slide the red, positive battery cable (Fig. 6) onto positive battery post and tighten nut securely.

**Warning**

Incorrect battery cable routing could damage the machine and cables causing sparks. Sparks can cause the battery gasses to explode, resulting in personal injury.

- Always *disconnect* the negative (black) battery cable before disconnecting the positive (red) cable.
- Always *connect* the positive (red) battery cable before connecting the negative (black) cable.

3. Slide the black, negative battery cable (Fig. 6) onto negative battery post and tighten nut securely.
4. Coat both battery connections with either Grafo 112X (skin-over) grease, Toro Part No. 505-47, petroleum jelly or light grease to prevent corrosion and **slide rubber boot over positive terminal** (Fig. 6).
5. Install the instrument cover and lock the two latches.

## Installing the Ball Joint and Connecting the Lift Cylinder

**Note:** Ball joints are not required for all implements; refer to implement operator's manual for requirements.

1. Thread jam nut fully onto right-hand ball joint.
2. Screw ball joint into right hand push arm until center of ball joint is 2-3/8 in. (60 mm) away from front of push arm (Fig. 17). Do not tighten jam nut.

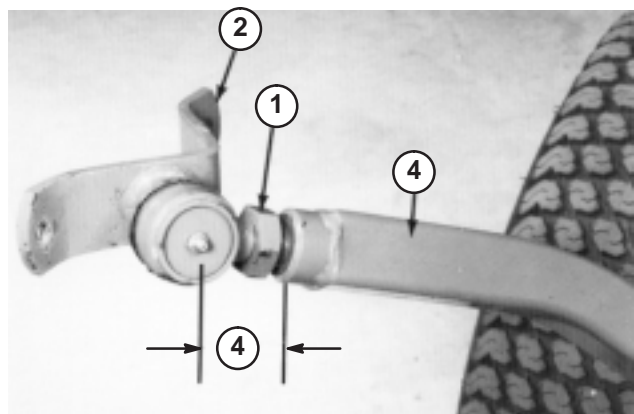

Figure 17

1. Jam nut
2. Ball joint mount
3. 2-3/8 in. (60 mm)
4. Right-hand push arm



**Warning**

**Sudden release of the spring-loaded push arms could cause injury.**

**Acquire the help of another person to help push the arms down during installation of the ball joints or other implements.**

3. Have a helper push down on the left push arm. Then insert a 2 x 4 in. (51 x 102 mm) block of wood between the frame and top of the push arm (Fig. 18). Screw ball joint into left hand push arm until center of ball joint is 2-3/8 in. (60 mm) away from front of push arm (Fig. 18). Do not tighten jam nut.

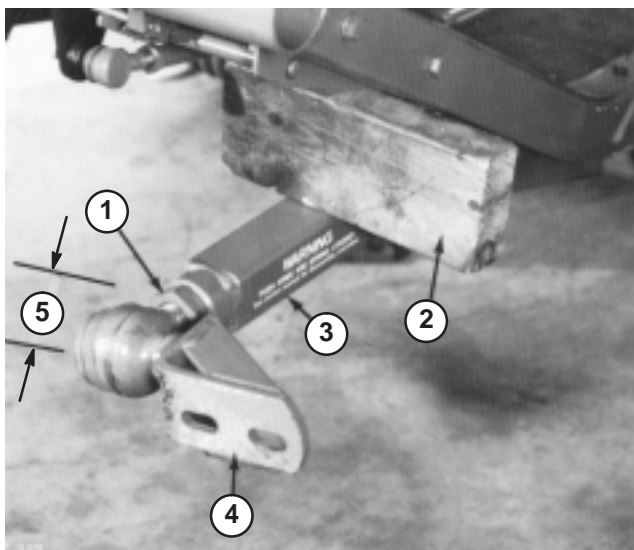

**Figure 18**

- |                                  |                       |
|----------------------------------|-----------------------|
| 1. Jam nut                       | 3. Left-hand push arm |
| 2. 2 x 4 in. (51 x 102 mm) block | 4. Ball joint mount   |
|                                  | 5. 2-3/8 in. (60 mm)  |

4. Carefully remove 2 x 4 in. (51 x 102 mm) block of wood from between frame and push arm.

5. Remove spring pin from cylinder pin and slide cylinder pin out of cylinder.
6. Raise front of lift arm until hole in movable end of cylinder lines up with holes in lift arm brackets. Use caution as lift arm is spring-loaded. Hold parts together with cylinder pin, spring pin, and cotter pin. Cotter pin must be to the outside.
7. Install implement; refer to implement Operator's Manual for proper installation procedures.

## Checking the Tire Pressure

The tires are over-inflated for shipping. Therefore, release some of the air to reduce the pressure. Correct air pressure in the front and rear tires is 21 psi (145 kPa).

## Checking the Torque of the Front Wheel Nuts

**Warning**

**Failure to maintain proper torque of the front wheel nuts could result in failure, loss of wheel, or personal injury.**

**Torque the front wheel nuts to 45–55 ft.-lb. (61–75 N·m) after 1–4 hours of operation and again after 10 hours of operation. Torque every 250 hours thereafter.**

## Greasing the Traction Unit

Before the machine is operated, it must be greased to assure proper operating characteristics; refer to Lubrication Maintenance. Failure to grease the machine will result in premature failure of critical parts.

**Note:** After setup has been completed, remove protective edging (used for shipping) from fenders.

## Install Rear Weight

To comply with CEN standard EN 836:1997, ISO standard 5395:1990 and ANSI/OPEI B71.4–1999 Standard, rear weight must be added to rear of traction unit. Use chart below to determine weight requirements. Order parts from your local Authorized Toro Distributor.

**Note:** A rear weight kit, part no. 24–5780 is supplied with Model No. 30630.

### Two Wheel Drive

Cutting Unit Description	Rear Weight Required	Weight Part Number	Weight Description	Qty.
72" Side Discharge (Model No. 30722)	70 lb.	24–5780	Rear Weight Kit (two 35 lb. weights and mounting hardware)	1
72" Rear Discharge (Model No. 30710)	70 lb.	24–5780	Rear Weight Kit (two 35 lb. weights and mounting hardware)	1
Guardian 72" Recycler (Model No. 30716)	70 lb.	24–5780	Rear Weight Kit (two 35 lb. weights and mounting hardware)	1
72" Flex Deck (Model 30799)	210 lb.	24–5780	Rear Weight Kit (two 35 lb. weights and mounting hardware)	3

### Four Wheel Drive

Cutting Unit Description	Rear Weight Required	Weight Part Number	Weight Description	Qty.
72" Flex Deck (Model 30799)	70 lb.	24–5780	Rear Weight Kit (two 35 lb. weights and mounting hardware)	1

# Before Operating

## Hood Prop

(Models 30626 & 30627 only)

1. Position the machine on a level surface.
2. Disengage hood latch and open the hood.
3. Slide bottom of hood prop (Fig. 19) out of retaining bracket. Lower hood prop, pivot upward, then downward to prop up hood.

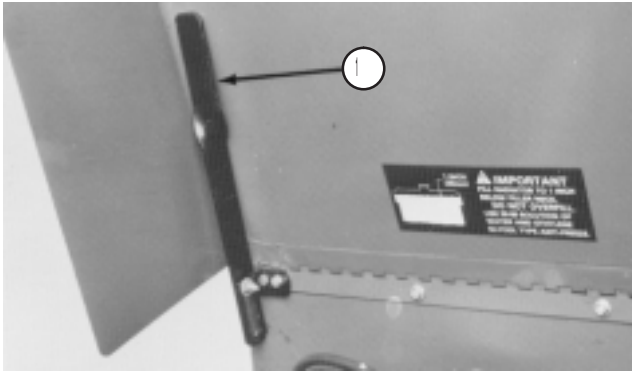

**Figure 19**

1. Hood prop

## Check Engine Oil

The engine is shipped with 3.25 qt (3.1 l) of oil in the crankcase; however, level of oil must be checked before and after the engine is first started.

1. Park machine on a level surface, stop engine and remove key from ignition switch. Open hood and install hood prop.
2. Remove dipstick (Fig. 20), wipe clean and reinstall dipstick. Remove dipstick and check oil level. Oil level should be up to FULL mark on dipstick

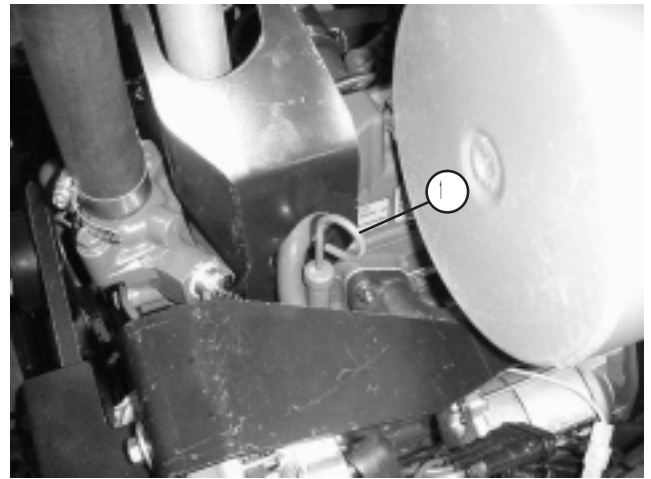

**Figure 20**

1. Dipstick

3. If oil is below FULL mark, remove fill cap and add SAE 10W-30 CD, CE, CF, CF-4 or CG-4 classification oil until level reaches FULL mark on dipstick. DO NOT OVERFILL.

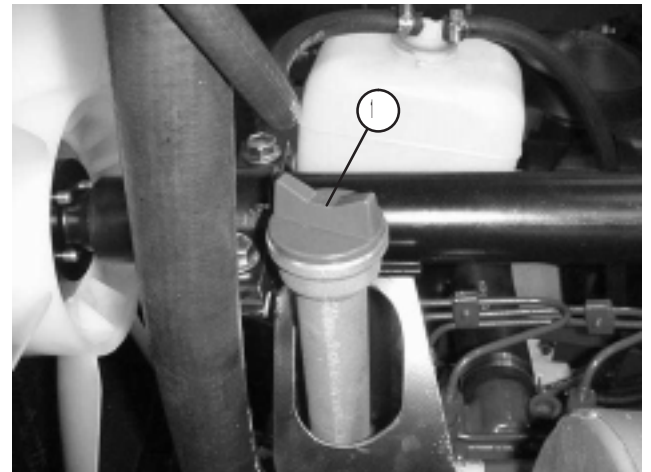

**Figure 21**

1. Oil fill

4. Install oil fill cap and close hood.

## Filling the Fuel Tank

**Danger**

Under certain conditions, diesel fuel and fuel vapors are highly flammable and explosive. A fire or explosion from fuel can burn you and others and can cause property damage.

- Use a funnel and fill the fuel tank outdoors, in an open area, when the engine is off and is cold. Wipe up any fuel that spills.
- Do not fill the fuel tank completely full. Add fuel to the fuel tank until the level is 1 in. (25 mm) below the bottom of the filler neck. This empty space in the tank allows the fuel to expand.
- Never smoke when handling fuel, and stay away from an open flame or where fuel fumes may be ignited by a spark.
- Store fuel in a clean, safety-approved container and keep the cap in place.

1. Tip seat forward and prop it with the support rod so it cannot fall accidentally. Using a clean rag, clean area around fuel tank cap (Fig. 22).
2. Remove cap from the fuel tank and fill the 6-1/2 gallon (25 l) tank to within 1 in. (25 mm) from the top with diesel fuel. Install fuel tank cap tightly after filling tank.

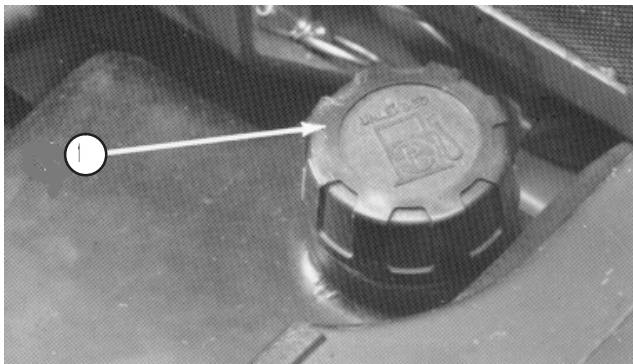

**Figure 22**

1. Fuel tank cap

## Check Cooling System

Clean debris off screen and radiator/oil cooler daily, more often if conditions are extremely dusty and dirty.

The cooling system is filled with a 50 / 50 solution of water and permanent ethylene glycol anti-freeze. Check level of coolant in expansion tank at beginning of each day before starting the engine. Capacity of cooling system is 6 quarts (5.6 l).

**Caution**

- If engine has been running, pressurized hot coolant can escape when radiator cap is removed and cause burns.

1. Check level of coolant in expansion tank. Coolant level should be between the marks on side of tank.

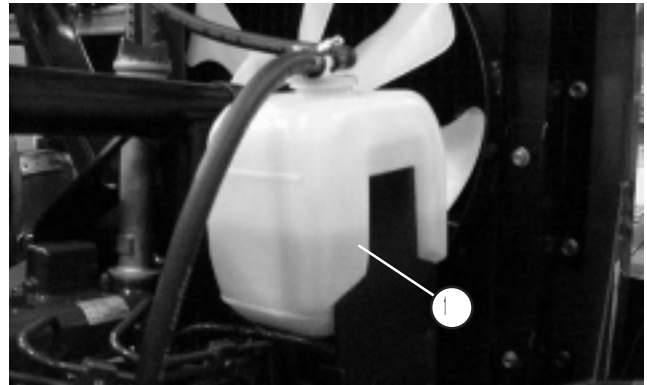

**Figure 23**

1. Expansion tank

---

2. If coolant level is low, remove expansion tank cap and replenish the system. DO NOT OVERFILL.
3. Install expansion tank cap.

## Checking the Hydraulic System Fluid

The front axle housing acts as the reservoir for the system. The transmission and axle housing are shipped from the factory with approximately 5 quarts (4.7 l) of high quality hydraulic fluid. However, check fluid level before engine is first started and daily thereafter.

**Note:** Fluid to operate the power steering is supplied by the hydraulic system transmission charge pump. Cold weather start-up may result in “stiff” operation of the steering until the hydraulic system has warmed up.

The following list is not assumed to be all-inclusive. Hydraulic fluids produced by other manufacturers may be used if they can cross reference to find an equivalent to the products listed. Toro will not assume responsibility for

damage caused by improper substitutions, so use only products from reputable manufacturers who will stand behind their recommendation.

### Universal Tractor Hydraulic Fluid

Mobil	Mobil Fluid 424
Amoco	1000 Fluid
Chevron	Tractor Hydraulic Fluid
Conoco	Power-Tran 3
Exxon	Torque Fluid
Pennzoil	Hydra-Tranz
Shell	Donax TD
Texaco	TDH

**Note:** Many hydraulic fluids are almost colorless, making it difficult to spot leaks. A red dye additive for the hydraulic system oil is available in 2/3 oz. (20 ml) bottles. One bottle is sufficient for 4–6 gal (15–22 l) of hydraulic oil. Order part no.44–2500 from your authorized Toro distributor.

1. Position machine on a level surface, raise the implement, and stop the engine.
2. Unscrew dipstick cap (Fig. 24) from the filler neck and wipe it with a clean rag. Screw dipstick cap finger tight onto filler neck. Unscrew the dipstick and check level of fluid. If level is not within 1/2 in. (13 mm) from the groove in the dipstick (Fig. 24), add enough fluid to raise level to groove mark. **Do not overfill** by more than 1/2 in. (13 mm) above groove.

**Important** When adding oil to the hydraulic system, use a funnel with a fine wire screen—200 mesh—and ensure funnel and oil are immaculately clean. This procedure prevents accidental contamination of the hydraulic system.

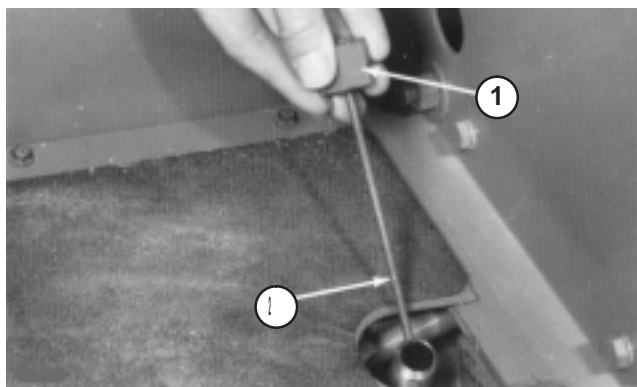

**Figure 24**

1. Dipstick cap
2. Groove

3. Screw dipstick filler cap finger-tight onto filler neck. It is not necessary to tighten cap with a wrench.
4. Lower the implement.

## Checking the Rear Axle

The rear axle has three separate reservoirs which use SAE 80W-90 wt. gear lube. Although the axle is shipped with lubricant from the factory, check the level before operating the machine.

1. Position the machine on a level surface.
2. Remove check plugs from axle and make sure lubricant is up to bottom of each hole. If level is low, remove fill plugs and add enough lubricant to bring the level up to the bottom of the check plug holes (Fig. 25).

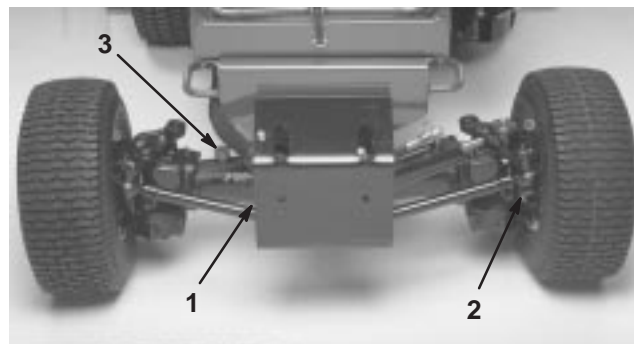

**Figure 25**

1. Check plug
2. Fill/check plug (one on each end of axle)
3. Fill plug

## Check Bidirectional Clutch Lubricant

(Models 30627 & 30631 only)

1. Position the machine on a level surface.
2. Rotate clutch (Fig. 26) so check plug (shown in 12 o'clock position) is positioned at 4 o'clock.

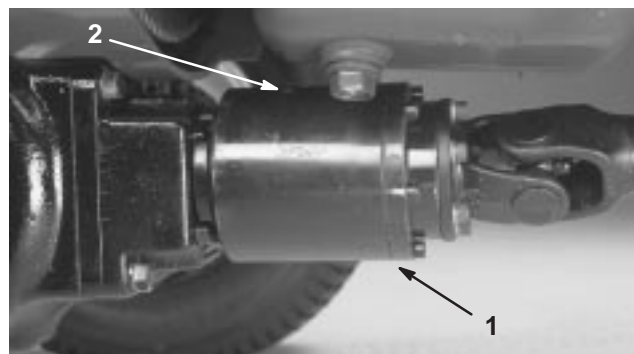

**Figure 26**

1. Bidirectional clutch
2. Check plug



3. Remove check plug. Fluid level should be up to hole in clutch. If fluid level is low, add Mobil Fluid 424. Clutch should be approximately 1/3 full.
4. Install check plug.

**Note:** Do not use engine oil (i.e. 10W30) in bidirectional clutch. Anti-wear and extreme pressure additives will cause undesirable clutch performance.

## Operation

**Note:** Determine the left and right sides of the machine from the normal operating position.

## Controls

### Traction Pedal

The traction pedal (Fig. 27) has two functions; one is to make the machine move forward, the other is to make it move backward. Using the heel and toe of the right foot, depress top of pedal to move forward and bottom of pedal to move backward. Ground speed is proportionate to how far pedal is depressed. For maximum ground speed with no load, traction pedal must be fully depressed while throttle is in FAST position. Maximum speed forward is approximately 9.5 mph (15 km/h). To get maximum power under heavy load or when ascending a hill, have throttle in FAST position while depressing traction pedal slightly to keep engine rpm high. When engine rpm begins to decrease, release traction pedal slightly to allow engine rpm to increase.

**Caution**

**When foot is removed from the traction pedal, machine should stop; it must not creep in either direction. If machine does creep, do not operate until neutral assembly has been repaired and adjusted; refer to Adjusting Traction Drive for Neutral.**

### Turn Pedals

The left and right turn pedals (Fig. 27) are connected to the left and right front wheel brakes since both brakes work independently of each other. The brakes can be used to turn sharply or to increase traction if one wheel tends to slip while operating on a hillside. However, wet grass or soft turf could be damaged when brakes are used to turn.

## Tilt Steering Control

The tilt steering control is a lever on right side of steering column (Fig. 27). Pull lever rearward to adjust steering wheel to desired fore or aft operating position and push lever forward to lock adjustment.

**Caution**

**Do not leave lever in unlocked position.**

### Brake Pedal

Whenever the engine is shut off, the parking brake (Fig. 27) must be engaged to prevent accidental movement of the machine.

The hydrostatic transmission will not, at any time, act as a parking brake for the machine. To engage parking brake, push down fully on brake pedal and pull parking brake knob out; then release the pedal. To release parking brake, depress brake pedal until parking brake knob retracts. To stop quickly, remove right foot from traction pedal and depress the brake pedal. To permit straight stops, brake cables must be evenly adjusted.

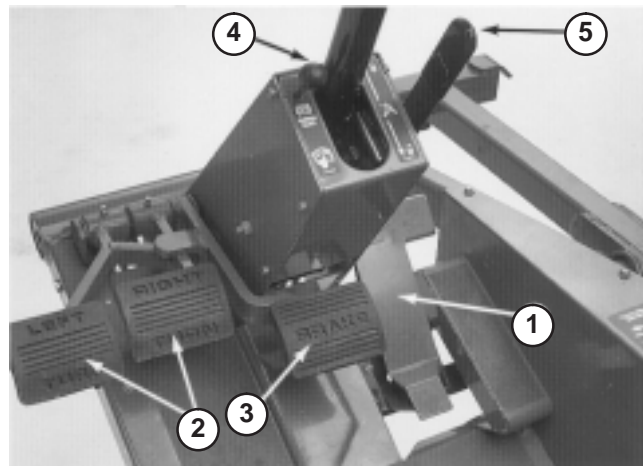

**Figure 27**

- |                   |                          |
|-------------------|--------------------------|
| 1. Traction pedal | 4. Parking brake knob    |
| 2. Turn pedals    | 5. Tilt steering control |
| 3. Brake pedal    |                          |

### Lift Lever

The hydraulic lift lever (Fig. 28) has three positions: FLOAT, TRANSPORT, and RAISE. To lower implement to the ground, move lift lever forward into detent, which is the FLOAT position. The FLOAT position is used for operation and also when machine is not in operation. To raise implement, pull lift lever backward to the RAISE position. After implement is raised, allow lift lever to move to the

TRANSPORT position. Normally, implement should be raised when driving from one work area to another, except when descending steep slopes.

⚠
Caution
⚠

**The exposed, rotating blades of the cutting unit or other implements are hazardous.**

**Never raise a cutting unit or implement while the blades or other components are rotating.**

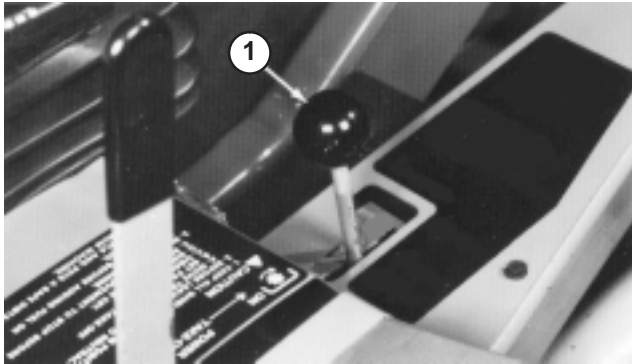

**Figure 28**

1. Lift lever

### PTO Lever

The PTO lever (Fig. 29) has two positions: ON (engage) and OFF (disengage). Slowly push PTO lever fully forward to ON position to start the implement or cutting unit blades. Slowly, pull lever backward to OFF position to stop implement operation. The only time PTO lever should be in the ON position is when implement or cutting unit is down in operating position.

### Fuel Gauge

The fuel gauge (Fig. 29) indicates quantity of fuel remaining in fuel tank.

### Hour Meter

The hour meter (Fig. 29) registers accumulated hours of engine operation.

### Oil Pressure Warning Light

The oil pressure warning light (Fig. 29) glows when oil pressure in engine drops below a safe level. If low oil pressure ever occurs, stop engine and determine the cause. Repair the damage before starting the engine again.

### Charge Indicator

Illuminates when system charging circuit malfunctions (Fig. 29).

### Engine Coolant Temperature Warning Light

The light illuminates and engine shuts down when coolant reaches a excessively high temperature (Fig. 29).

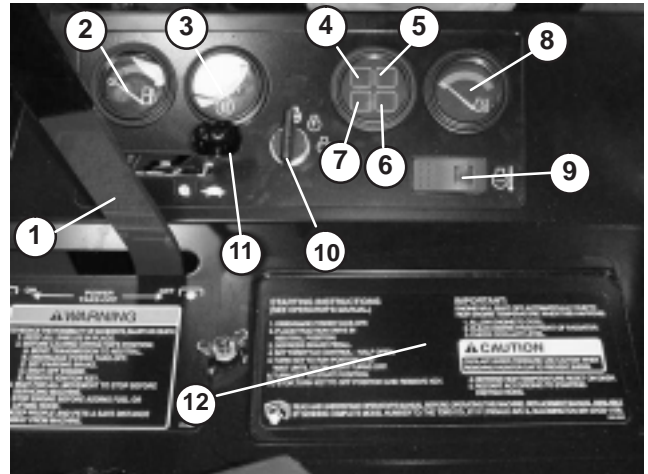

**Figure 29**

- |                           |                                |
|---------------------------|--------------------------------|
| 1. PTO lever              | 8. Temperature gauge           |
| 2. Fuel gauge             | 9. Temperature override switch |
| 3. Hour meter             | 10. Key switch                 |
| 4. Oil pressure indicator | 11. Throttle control           |
| 5. Engine temperature     | 12. Battery cover              |
| 6. Glow plug indicator    |                                |
| 7. Charge indicator       |                                |

### Temperature Gauge

The temperature gauge (Fig. 29) registers the temperature of the coolant in the cooling system. If temperature of coolant gets too high the engine will shut off automatically.

### Temperature Override Switch

Press and hold override switch to start engine after high temperature shut down. Use only for emergency operation.

### Glow Plug Indicator

When lit, indicates glow plugs are on (Fig. 29).

### Key Switch

Three positions: OFF, ON / Preheat and START (Fig. 29).



## Throttle Control

The throttle (Fig. 29) is used to operate engine at various speeds. Moving throttle forward increases engine speed—FAST; backward decreases engine speed—SLOW. The throttle regulates the speed of the cutter blades or other implement components and, in conjunction with traction pedal, controls ground speed of the traction unit.

## Seat Adjusting Lever

To adjust standard seat, push lever (Fig. 30) backward and slide seat to the desired position. Release lever to lock seat in place. The suspension seat may be adjusted forward or rearward by pulling out the lever at the left side of the seat, sliding the seat to the desired position, and releasing the lever. The weight adjustment knob may be adjusted for any operator's comfort.

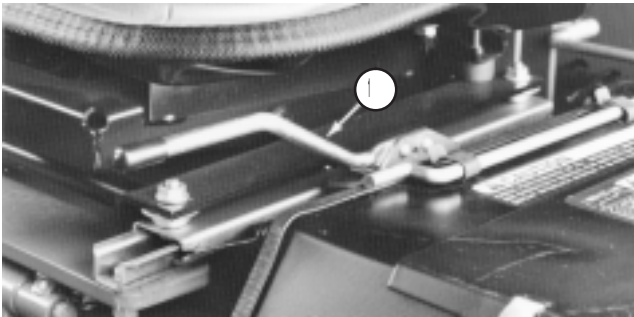

Figure 30

1. Seat adjusting lever

## Starting/Stopping Engine

**Important** The fuel system must be bled if any of the following situation have occurred.

- A. Initial start up of a new machine.
- B. Engine has ceased running due to lack of fuel.
- C. Maintenance has been performed upon fuel system components; i.e., filter replaced, separator serviced, etc.

Refer to Bleeding The Fuel System.

1. Ensure parking brake is set, PTO switch is in OFF position and lift lever is in TRANSPORT or FLOAT position. Remove foot from traction pedal and insure it is in neutral.
2. Move throttle control to 1/2 throttle position.
3. Turn ignition switch to ON / Preheat position. An automatic timer will control preheat for 10 seconds. After preheat, turn key to START position. CRANK ENGINE FOR NO LONGER THAN 15 SECONDS.

Release key when engine starts. If additional preheat is required, turn key to OFF position then to ON / preheat position. Repeat process as required.

4. Run engine at idle speed or partial throttle until engine warms up.

**Note:** Move throttle to 1/2 throttle position when restarting a warm engine.

5. When engine is started for the first time, or after engine oil change, or overhaul of engine, transmission or axle, operate the machine in forward and reverse for one to two minutes. Also operate the lift lever and PTO lever to assure proper operation of all parts. Turn power steering wheel to the left and right to check steering response. Then shut engine off and check fluid levels, check for oil leaks, loose parts and any other noticeable malfunctions.



### Caution



- Shut engine off and wait for all moving parts to stop before checking for oil leaks, loose parts or other malfunctions.

6. To stop engine, move throttle control backward to SLOW position, move PTO switch to OFF position and rotate ignition key to OFF. Remove key from switch to prevent accidental starting.

## Bleeding Fuel System

1. Park the machine on a level surface. Make sure fuel tank is at least half full.
2. Unlatch and raise hood.



### Danger



Under certain conditions, diesel fuel and fuel vapors are highly flammable and explosive. A fire or explosion from fuel can burn you and others and can cause property damage.

- Use a funnel and fill the fuel tank outdoors, in an open area, when the engine is off and is cold. Wipe up any fuel that spills.
- Do not fill the fuel tank completely full. Add fuel to the fuel tank until the level is 1 in. (25 mm) below the bottom of the filler neck. This empty space in the tank allows the fuel to expand.
- Never smoke when handling fuel, and stay away from an open flame or where fuel fumes may be ignited by a spark.
- Store fuel in a clean, safety-approved container and keep the cap in place.

3. Open the air bleed screw on the fuel injection pump (Fig. 31).

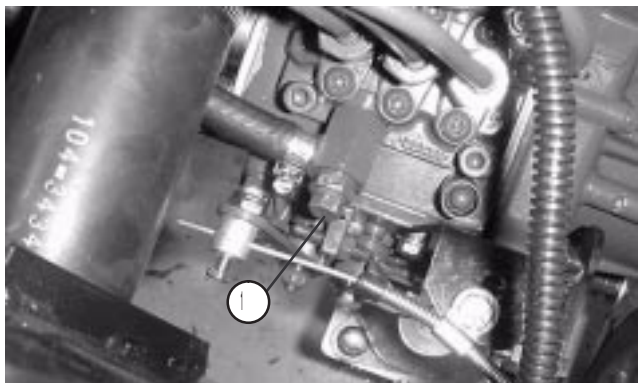

**Figure 31**

1. Fuel injection pump bleed screw

4. Turn key in ignition switch to the ON position. Electric fuel pump will begin operation, thereby forcing air out around air bleed screw. Leave key in ON position until solid stream of fuel flows out around screw. Tighten screw and turn key to OFF.

**Note:** Normally, engine should start after above bleeding procedures are followed. However, if engine does not start, air may be trapped between injection pump and injectors; refer to Bleeding Air From Injectors.

## Checking the Interlock Switches



### Caution



If safety interlock switches are disconnected or damaged the machine could operate unexpectedly causing personal injury.

- Do not tamper with the interlock switches.
- Check the operation of the interlock switches daily and replace any damaged switches before operating the machine.
- Replace switches every two years or 1000 hours, whichever occurs first, regardless of whether they are operating properly or not.

The machine has interlock switches in the electrical system. These switches are designed to stop the engine when operator gets off the seat while either the PTO lever is engaged or traction pedal is depressed. However, operator may get off the seat while engine is running. Although engine will continue to run if PTO lever is disengaged and traction pedal is released, it is strongly recommended that the engine be stopped before dismounting from the seat.

To check operation of interlock switches:

1. Drive the machine slowly to a large, relatively open area. Lower cutting unit, stop the engine and apply parking brake.
2. Sit on seat. Move PTO lever to ON position. With the traction pedal in neutral position, try to start the engine. The engine should not crank. If the engine cranks, there is a malfunction in the interlock system that should be corrected before beginning operation.
3. Sit on seat. Move PTO lever to OFF and depress the traction pedal. Try to start the engine. The engine should not crank. If the engine cranks, there is a malfunction in the interlock system that should be corrected before beginning operation.



### Warning



**Do not operate the machine without an implement unless the PTO driveshaft is also removed.**

4. Sit on seat and start the engine. Disengage the parking brake. Raise off the seat and move the PTO lever to ON. The engine should stop within 2–3 seconds. If the engine does not stop, there is a malfunction in the interlock system that should be corrected before beginning operation.
5. Engage the parking brake. Depress the traction pedal while engine is running and the PTO lever is disengaged. The engine should stop within 2 seconds. If engine stops, the switch is operating correctly; thus, continue operation. If engine does not stop, there is a malfunction in the interlock system that should be corrected before beginning operation.

## Pushing or Towing the Traction Unit

In an emergency, the traction unit can be pushed or towed for a very short distance. However, Toro does not recommend this as standard procedure.

**Important** Do not push or tow the traction unit faster than 2 to 3 MPH (3 to 4.8 km/h) because transmission may be damaged. If traction unit must be moved a considerable distance, transport it on a truck or trailer. Whenever traction unit is pushed or towed, bypass valve must be open.

1. Reach under traction unit and rotate bypass valve (Fig. 32) 1/2 to 1 turn counterclockwise. Opening the valve opens an internal passage in the transmission, thereby bypassing transmission oil. Because fluid is bypassed, traction unit can be moved without damaging the transmission.

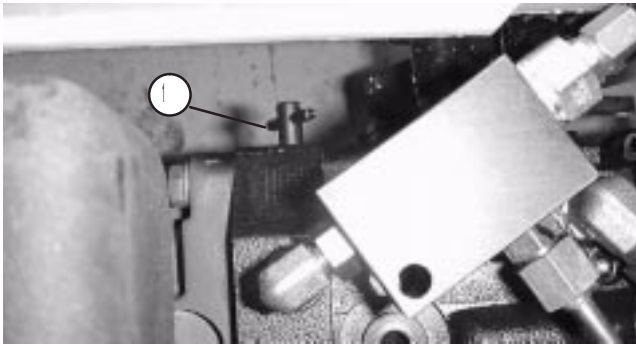

**Figure 32**

1. Bypass valve
2. Before starting engine, close bypass valve by rotating it clockwise until it is securely seated. Do not exceed 5 to 8 ft.-lb. (7 to 11 N-m). Do not start engine when valve is open.

**Important** Running the machine with bypass valve open will cause the transmission to overheat.

## Operating Characteristics

Practice driving the machine because it has a hydrostatic transmission and its characteristics are different than many turf maintenance machines. Some points to consider when operating the traction unit, cutting unit, or other implement are the transmission, engine speed, load on the cutting blades or other implement components, and the importance of the brakes.

To maintain enough power for the traction unit and implement while operating, regulate traction pedal to keep engine rpm high and somewhat constant. A good rule to follow is: decrease ground speed as the load on the implement increases, and increase ground speed as the load decreases.

Therefore, allow traction pedal to move backward as engine rpm decrease, and depress pedal slowly as rpm increase. By comparison, when driving from one work area to another—with no load and cutting unit raised—have throttle in FAST position and depress traction pedal slowly but fully to attain maximum ground speed.

Another characteristic to consider is the operation of the turning pedals that are connected to the brakes. The brakes can be used to assist in turning the machine. However, use them carefully, especially on soft or wet grass because the turf may be torn accidentally. Another benefit of the turning brakes is to maintain traction. For example: in some slope conditions, the uphill wheel slips and loses traction. If this situation occurs, depress uphill turn pedal gradually and intermittently until the uphill wheel stops slipping, thus, increasing traction on the downhill wheel.

Use extra care when operating machine on slopes. Always have seat pivot retaining pin installed. Drive slowly and avoid sharp turns on slopes to prevent roll overs. The cutting deck must be lowered when going downhill for steering control.

The grass deflector must always be installed and in lowest position on the side discharge cutting unit.



### Warning



**Careless operation, combined with terrain angle, ricochets, or improperly positioned safety guards can lead to thrown object injuries.**

**A person or pet may suddenly appear in or near the mowing area.**

**Stop mowing and do not resume mowing until the area is cleared.**

Before stopping the engine, disengage all controls and move throttle to SLOW. Moving throttle to SLOW reduces high engine rpm, noise, and vibration. Turn key to OFF to stop engine.

# Maintenance

**Note:** Determine the left and right sides of the machine from the normal operating position.

## Recommended Maintenance Schedule

Maintenance Service Interval	Maintenance Procedure
After first 10 hours	<ul style="list-style-type: none"> <li>• Check the PTO belt tension.</li> <li>• Check the fan and alternator belt tension.</li> <li>• Change the transmission filter.</li> <li>• Torque the wheel lug nuts.</li> </ul>
After first 50 hours	<ul style="list-style-type: none"> <li>• Change the engine oil and filter.</li> <li>• Check engine RPM.</li> <li>• Check the PTO belt tension.</li> <li>• Torque head, adjust valves and check engine RPM</li> </ul>
Every 50 hours	<ul style="list-style-type: none"> <li>• Check the battery electrolyte level.</li> <li>• Check the battery cable connections.</li> <li>• Lubricate all grease fittings.</li> <li>• Lubricate the brake cables.</li> <li>• Check the cutting unit gear box oil level.</li> <li>• Clean under the cutting unit belt covers.</li> <li>• Check the cutting unit drive belt adjustment.</li> <li>• Inspect the air filter.</li> </ul>
Every 100 hours	<ul style="list-style-type: none"> <li>• Change the engine oil and filter.</li> <li>• Check the PTO belt tension.</li> <li>• Check the fan and alternator belt tension.</li> <li>• Inspect the cooling system hoses.</li> </ul>
Every 200 hours	<ul style="list-style-type: none"> <li>• Service the air filter.</li> <li>• Check rear wheel toe-in and steering linkage.</li> <li>• Change the transmission filter.</li> <li>• Torque the wheel lug nuts.</li> </ul>
Every 400 hours	<ul style="list-style-type: none"> <li>• Replace the cutting unit gear box oil.</li> <li>• Change fuel filter.</li> <li>• Change the fuel/water separator filter.</li> <li>• Change rear axle lubricant (4 wheel drive only).</li> <li>• Change bidirectional clutch lubricant (4 wheel drive only).</li> <li>• Pack the rear wheel bearings (2 wheel drive only).</li> <li>• Torque head, adjust valves and check engine RPM</li> </ul>
Every 1000 hours or 2 years, whichever occurs first	<ul style="list-style-type: none"> <li>• Replace moving hoses.</li> <li>• Replace safety switches.</li> <li>• Flush and replace the coolant system fluid.</li> <li>• Replace the hydraulic fluid.</li> <li>• Drain and clean the fuel tank.</li> </ul>

**Important** Refer to your engine operator's manual for additional maintenance procedures.

# Daily Maintenance Checklist

Duplicate this page for routine use.

Maintenance Check Item	For the week of:						
	Mon.	Tues.	Wed.	Thurs.	Fri.	Sat.	Sun.
Check safety interlock operation.							
Check that the grass deflector is in the down position.							
Check brake operation.							
Check the engine oil level.							
Check the cooling system fluid level.							
Drain the water/fuel separator.							
Check the air cleaner.							
Check the radiator and screen for debris.							
Check unusual engine noises. <sup>1</sup>							
Check the transmission oil level.							
Check the hydraulic hoses for damage.							
Check for fluid leaks.							
Check the tire pressure.							
Check instrument operation.							
Check the condition of the blades.							
Lubricate all grease fittings. <sup>2</sup>							
Touch up damaged paint.							

<sup>1</sup>Check the glow plug and injector nozzles if hard starting, excess smoke, or rough running is noted.

<sup>2</sup>Immediately **after every** washing, regardless of the interval listed.

## Notation for Areas of Concern

Inspection performed by:		
Item	Date	Information
1		
2		
3		
4		
5		
6		
7		
8		
9		
10		



# Lubricating the Machine

The traction unit must be lubricated regularly. If machine is operated under normal conditions, lubricate all bearings and bushings after every 50 hours of operation.

The traction unit bearings and bushings that must be lubricated are:

## All Models

PTO shaft and yokes (3) (Fig. 33)

Lift arm pivots (Fig. 33)

Right and left push arm ball joints (Fig. 33)

Push arm pivot bushings (Fig. 34)

PTO pivot housing blocks (Fig. 35)

Brake pivot bushings (Fig. 36);

Engine output shaft bearing (Fig. 37)

## Four Wheel Drive Models

Axle tie rod (2) (Fig. 38)

Axle pivot pin (Fig. 38)

Axle steering pivots (2) (Fig. 38)

Cylinder rod ends (4) (Fig. 38)

Drive shaft (3) (Fig. 39)

Clutch housing (Fig. 39)

## Two Wheel Drive Models

Rear wheel spindle bushings (Fig. 40)

Steering plate bushings (Fig. 40)

Axle pin bushing (Fig. 40)

**Note:** Apply grease to both brake cables at the drive wheel and brake pedal ends.

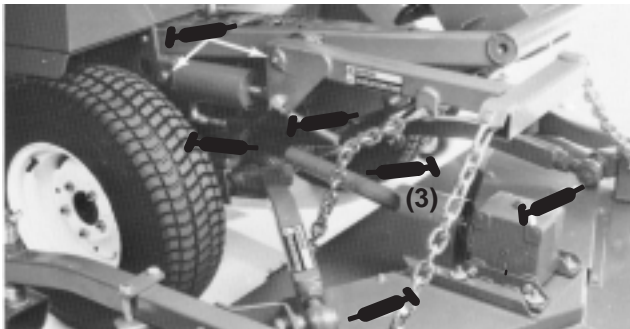

Figure 33

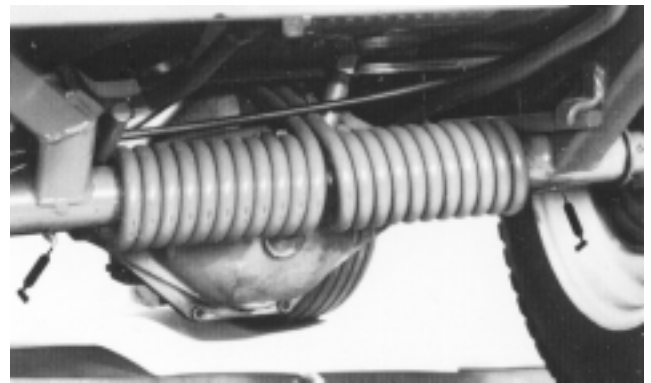

Figure 34



Figure 35

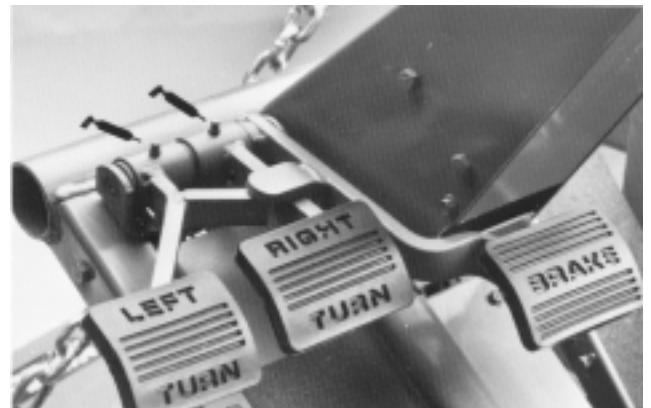

Figure 36

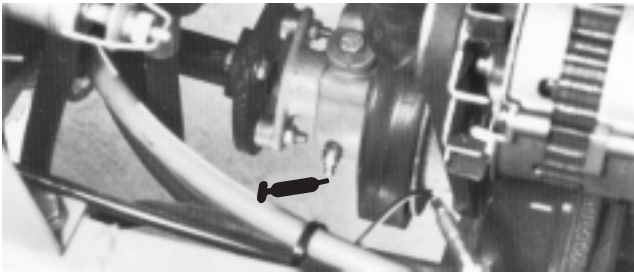

Figure 37

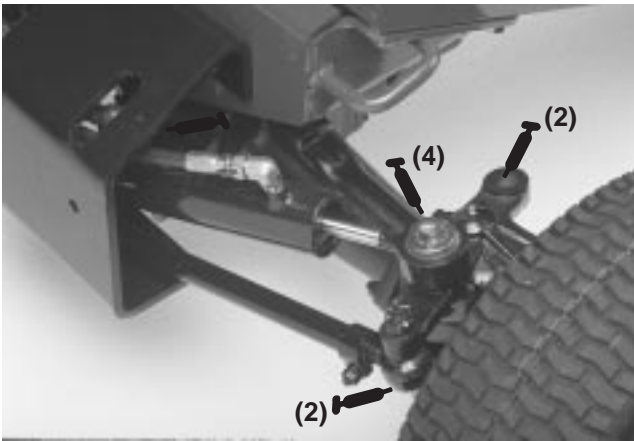

Figure 38

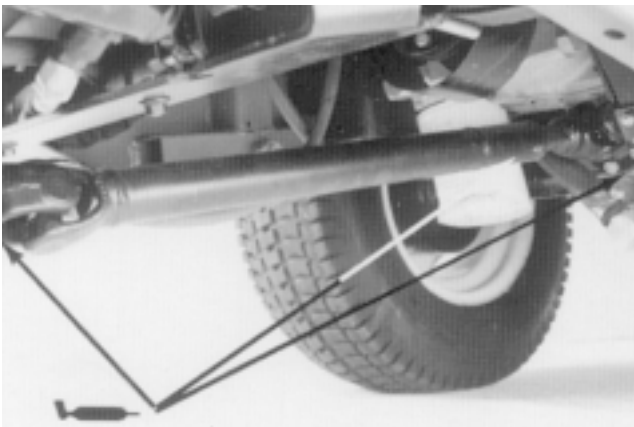

Figure 39

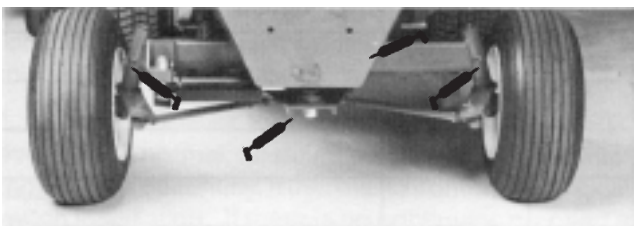

Figure 40

## General Air Cleaner Maintenance

- Check air cleaner body for damage which could possibly cause an air leak. Replace a damaged air cleaner body.
- Service the air cleaner filters when air cleaner indicator (Fig. 41) shows red or every 400 hours (more frequently in extreme dusty or dirty conditions). Do not over service air filter.

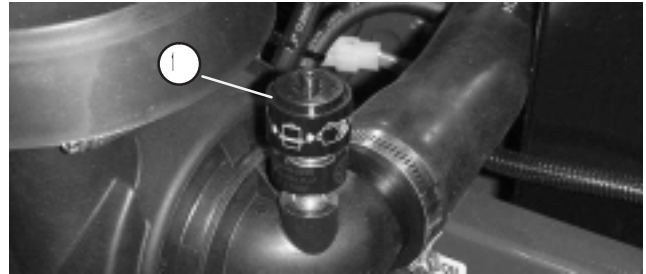

Figure 41

1. Air cleaner indicator

- Be sure cover is sealing around air cleaner body.

## Servicing Air Cleaner

1. Pull latch outward and rotate air cleaner cover counter-clockwise. Remove cover from body (Fig. 42). Clean inside of air cleaner cover.

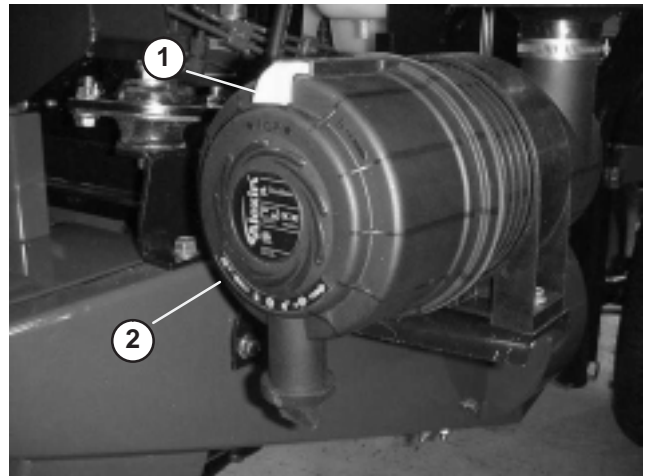
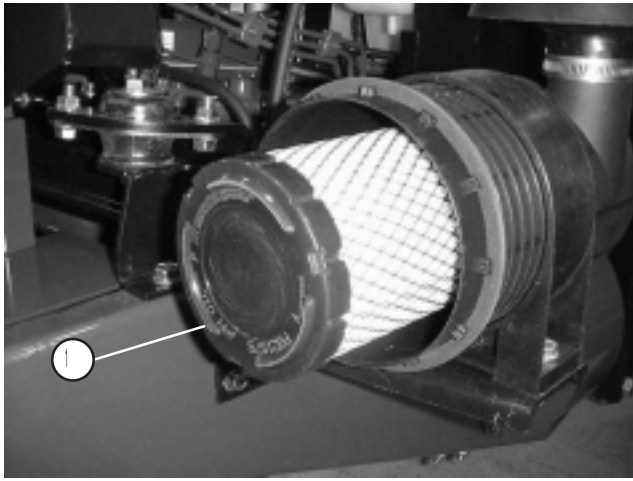

Figure 42

2. Air cleaner latch
3. Air cleaner cover

2. Gently slide primary filter (Fig. 43) out of air cleaner body to reduce the amount of dust dislodged. Avoid knocking filter against air cleaner body.





**Figure 43**

1. Primary filter

3. Inspect primary filter and discard if damaged. Do not wash or reuse a damaged filter.

### Cleaning Air Filter

- A. Blow compressed air from inside to the outside of dry filter element. Do not exceed 100 psi to prevent damage to the element.
- B. Keep air hose nozzle at least 2" from filter and move nozzle up and down while rotating the filter element. Inspect for holes and tears by looking through the filter toward a bright light.
4. Inspect new filter for shipping damage. Check sealing end of filter. Do not install a damaged filter.
5. Insert new filter properly into air cleaner body. Make sure filter is sealed properly by applying pressure to outer rim of filter when installing. Do not press on flexible center of filter.
6. Reinstall cover and secure latch. Make sure cover is positioned with TOP side up.
7. Reset indicator (Fig. 41) if showing red.

### Cleaning the Radiator and Screen

The screen and front of the radiator must be kept clean to prevent the engine from overheating. Normally, check the screen and front of radiator daily and, if necessary, clean any debris off these parts. However, it will be necessary to check and to clean the screen each quarter hour and radiator checked every hour in extremely dusty and dirty conditions.

**Note:** This situation may be particularly prevalent if the rear discharge cutting unit is being used. The front of the radiator can be cleaned thoroughly by blowing with compressed air from the fan side of the radiator. Make sure to clean out any debris that settles to the bottom of the screen. The screen in front of radiator can be removed—by loosening wing nuts at top of screen—to make cleaning easier.

### Changing Engine Oil And Filter

Check oil level after each day's operation or each time machine is used. Change oil and filter initially after first 50 hours of operation; change oil and filter after every 100 hours of operation thereafter. If possible, run engine just before changing oil because warm oil flows better and carries more contaminants than cold oil.

1. Position machine on a level surface.
2. Open the hood. Set drain pan under the oil pan and in line with drain plug (Fig. 44).

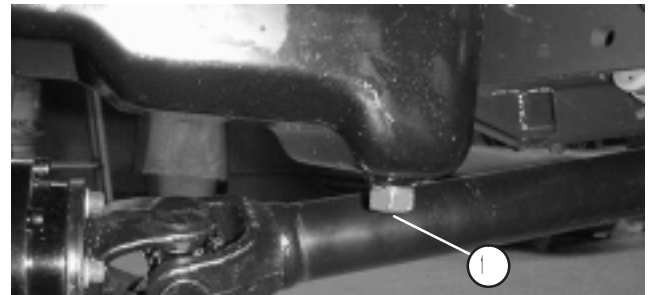

**Figure 44**

1. Drain plug
3. Clean area around drain plug.
4. Remove oil drain plug and allow oil to flow into drain pan.
5. Remove and replace oil filter (Fig. 45).



**Figure 45**

1. Oil filter
6. After oil is drained, reinstall drain plug and wipe up any oil that is spilled.
7. Fill crankcase with oil; refer to Check Crankcase Oil.

# Servicing Fuel System

**Note:** Refer to Fill Fuel Tank With Diesel Fuel for proper fuel recommendations.



## Danger



Under certain conditions, diesel fuel and fuel vapors are highly flammable and explosive. A fire or explosion from fuel can burn you and others and can cause property damage.

- Use a funnel and fill the fuel tank outdoors, in an open area, when the engine is off and is cold. Wipe up any fuel that spills.
- Do not fill the fuel tank completely full. Add fuel to the fuel tank until the level is 1 in. (25 mm) below the bottom of the filler neck. This empty space in the tank allows the fuel to expand.
- Never smoke when handling fuel, and stay away from an open flame or where fuel fumes may be ignited by a spark.
- Store fuel in a clean, safety-approved container and keep the cap in place.

## Fuel Tank

Drain and clean fuel tank every 1000 hours operation or every 2 years, whichever comes first. Also, drain and clean tank if fuel system becomes contaminated or if machine is to be stored for an extended period. Use clean diesel fuel to flush out the tank.

## Fuel Lines and Connections

Check lines and connections every 400 hours or yearly, whichever comes first. Inspect for deterioration, damage or loose connections.

## Water Separator

Drain water or other contaminants from water separator (Fig. 46) daily.

1. Place a clean container under water separator. Water separator is mounted to inside of frame, next to left side of engine.
2. Loosen drain plug on bottom of filter canister. Tighten plug after draining.

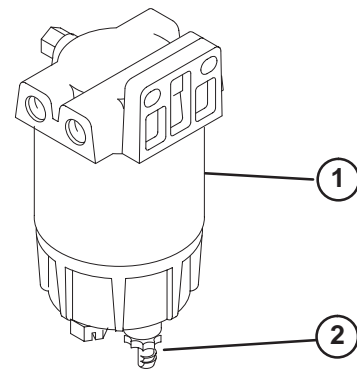

**Figure 46**

1. Water separator
2. Drain plug

Replace filter canister after every 400 hours of operation.

1. Clean area where filter canister mounts.
2. Remove filter canister and clean mounting surface.
3. Lubricate gasket on filter canister with clean oil.
4. Install filter canister by hand until gasket contacts mounting surface, then rotate an additional 1/2 turn.

## Replacing Fuel Pre Filter

Replace the fuel pre filter (Fig. 47), located between fuel tank and fuel pump after every 400 operating hours or yearly, whichever occurs first.

1. Clamp both fuel lines that connect to the fuel filter so fuel cannot drain when lines are removed.
2. Loosen the hose clamps at both ends of the filter and pull fuel lines off filter.

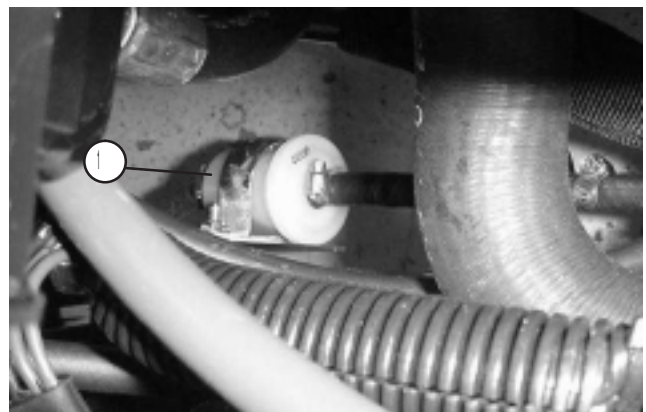

**Figure 47**

1. Fuel pre filter

3. Slide hose clamps onto ends of fuel lines. Push fuel lines onto fuel filter and secure them with hose clamps. Be sure arrow on side of filter points toward the injection pump.

## Bleeding Air From Injectors

**Note:** This procedure should be used only if fuel system has been purged of air through normal priming procedures and engine will not start; refer to Bleeding Fuel System.

1. Loosen the pipe connection to the No. 1 injector nozzle and holder assembly at injection pump (Fig. 48).

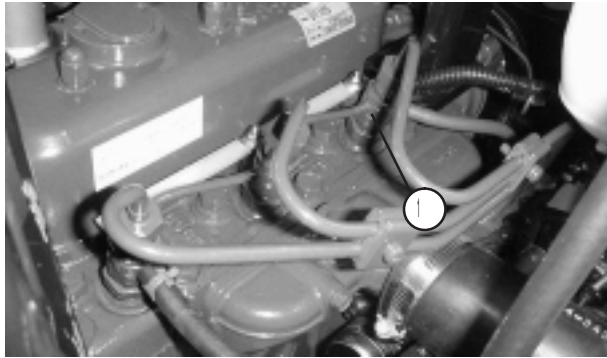

**Figure 48**

1. No. 1 injector nozzle

2. Move throttle to FAST position.
3. Turn key in key switch to START position and watch fuel flow around connector. Turn key to OFF position when solid flow is observed.
4. Tighten pipe connector securely.
5. Repeat steps on remaining nozzles.

## Cleaning Radiator And Screen

To prevent the engine from overheating, the screen and radiator must be kept clean. Normally, check the screen and radiator daily and, if necessary, clean any debris off these parts. However, it will be necessary to check and clean the screen and radiator frequently in extremely dusty and dirty conditions.

**Note:** If engine shuts off due to overheating, first check the radiator and screen for excessive buildup of debris.

To thoroughly clean the radiator:

1. Remove the screen.
2. Working from the fan side of the radiator, either spray the radiator with a water hose or blow with compressed air.

3. After the radiator is thoroughly cleaned, clean out debris that may have collected in the channel at the radiator base.
4. Clean and install the screen.

## Changing Coolant In Cooling System

Capacity of cooling system is approximately 6 quarts (5.7 L). The cooling system must be filled with a 50/50 solution of water and permanent ethylene glycol anti-freeze. Every two years, drain the coolant from the radiator by opening the drain cock (Fig. 49). After coolant is drained, flush the entire system and refill it with a 50/50 solution of water and anti-freeze.

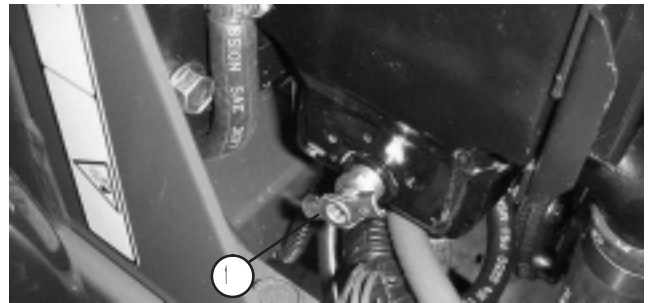

**Figure 49**

1. Drain cock

When filling the radiator, level of coolant must be above the core and 1 inch (25 mm) below bottom of filler neck. **DO NOT OVERFILL.** Always install radiator cap (Fig. 50) securely.

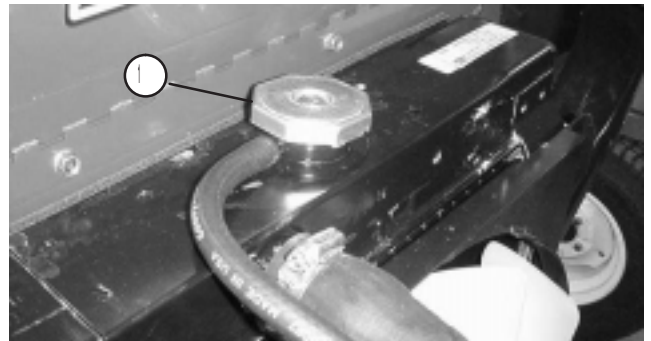

**Figure 50**

1. Radiator cap

Level of coolant in expansion tank (Fig. 51) should be between the marks on side of tank.

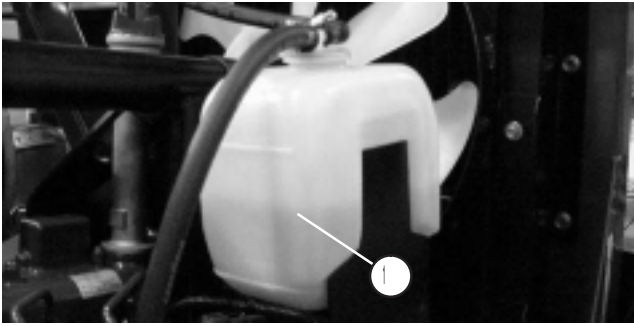

**Figure 51**

1. Expansion tank

## Servicing the Engine Belts

Check tension of all belts initially after the first day of operation and every 100 hours thereafter.

### Alternator Belt

1. Unlatch and open hood.
2. Proper tension will allow 3/8 in. (10 mm) deflection when a force of 10 lbs. is applied on the belt (Fig. 52) midway between the pulleys.
3. If deflection is not 3/8 in. (10 mm), loosen alternator mounting bolts. Increase or decrease alternator belt tension and tighten bolts. Check deflection of belt again to assure tension is correct.

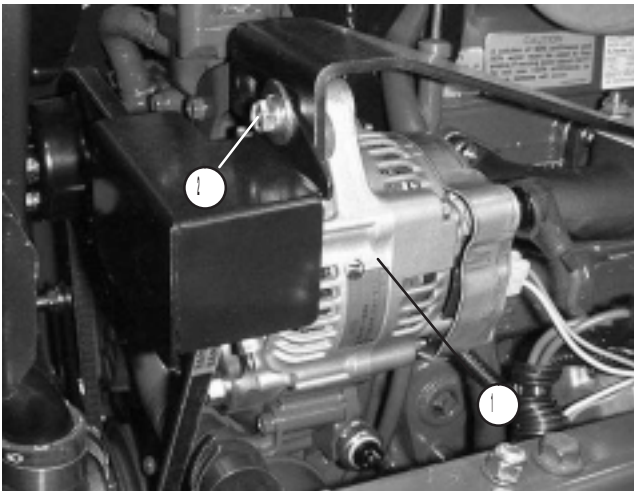
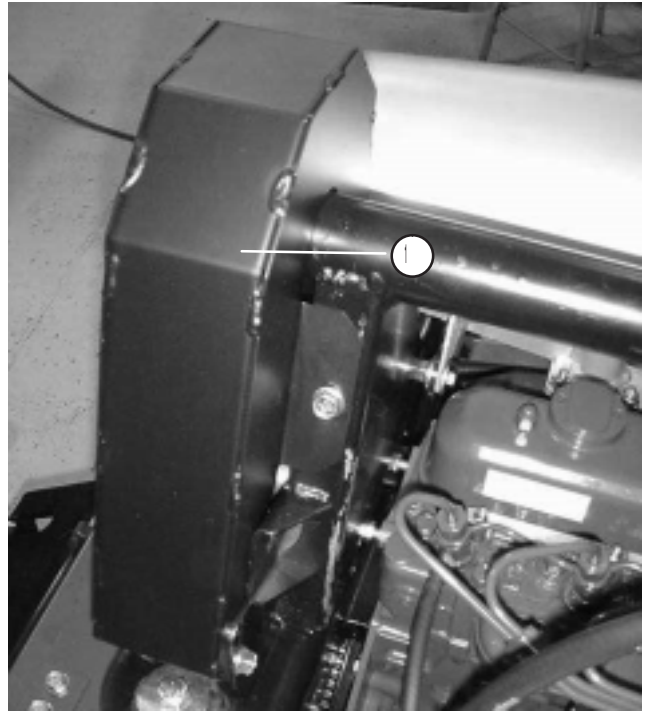

**Figure 52**

1. Alternator
2. Mounting bolt

### Cooling Fan Belt

1. Unlatch and open hood.
2. Remove capscrews (5) securing fan belt guard and remove guard (Fig. 53).



**Figure 53**

1. Fan belt guard

3. Belt should deflect 1/4 in. (6 mm) midway between the pulleys with 5 lb. force (22 n) (Fig. 54). If deflection is incorrect, proceed to step 4. If correct, proceed to step 5.

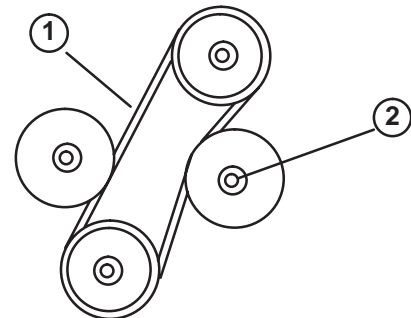

**Figure 54**

1. 1/4 in. (6 mm) deflection here
2. Adjustable Idler pulley locknut

4. Loosen locknut securing adjustable idler pulley (Fig. 54). Push idler pulley against belt until proper deflection is achieved and tighten idler pulley locknut (Fig. 54).



5. Install fan belt guard and secure with capscrews (Fig. 53). Close and latch hood.

**To replace belt:**

1. Follow procedures in step 1 and 2 above.
2. Loosen locknut securing adjustable idler pulley, slide pulley away from belt, and remove belt from pulleys (Fig. 54).
3. Install new belt and adjust for proper tension. Push idler pulley against belt until belt deflects 1/4 inch (6 mm) with 5 lb. force (22 N·m) midway between top pulley and stationary idle pulley. Tighten idler pulley locknut to secure adjustments (Fig. 54).
4. Install fan belt guard and secure with capscrews (Fig. 53). Close and latch hood.

**Note:** Check fan belt tension after first day's operation. Readjust tension, if necessary. Follow regular maintenance check procedure thereafter.

## Adjusting Throttle

1. Adjust throttle cable (Fig. 55) so governor lever on engine contacts low and high speed set bolts before throttle lever contacts slot in control panel.

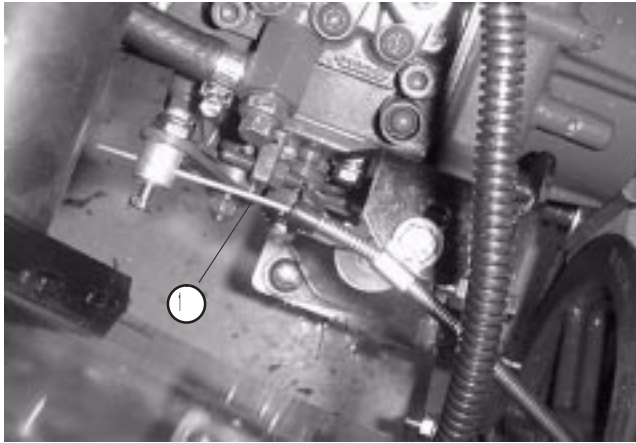
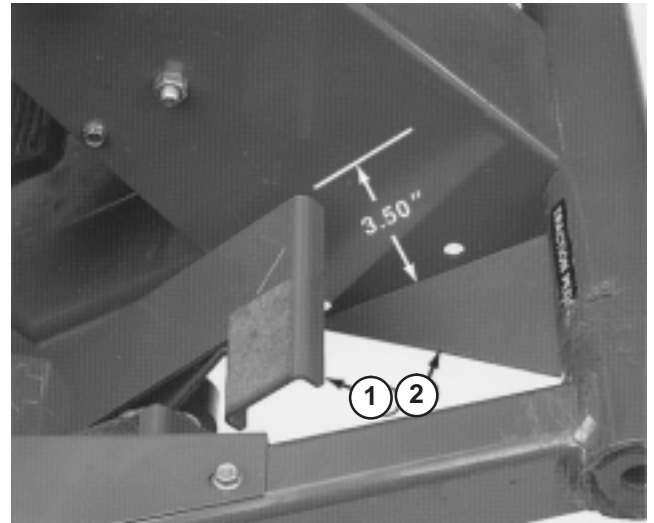

**Figure 55**

1. Throttle cable

## Adjusting Traction Control Rod

1. Check traction drive neutral position to assure front wheels do not creep; refer to Adjusting Traction Drive for Neutral.
2. Press down on front of traction pedal and check travel. There should be approximately 3.50" clearance between end of pedal and floor plate when pedal in fully depressed (Fig. 56). Adjust pump control rod (Fig. 57) to attain dimension.



**Figure 56**

1. End of pedal
2. Floor plate

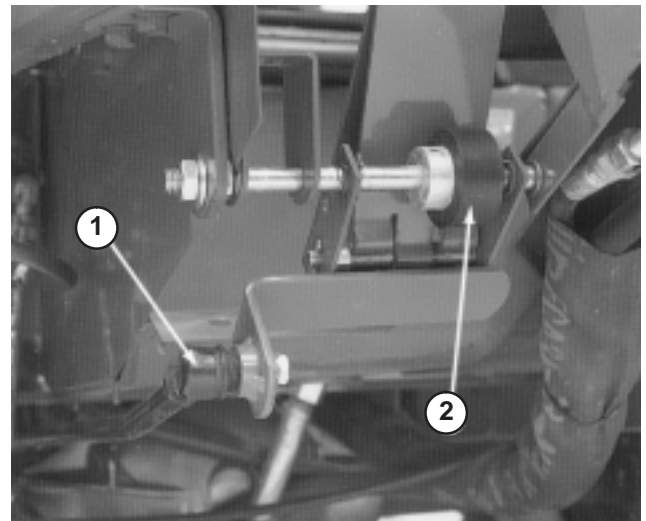

**Figure 57**

1. Control rod
2. Friction wheel

## Adjusting Traction Pedal Friction Wheel

1. Loosen two nuts securing traction pedal shaft on right side of pedal (Fig. 57).
2. Rotate shaft to relocate worn surface of friction wheel away from underside of traction pedal.
3. Tighten nuts to secure shaft and wheel in position.

## Adjusting the Traction Drive for Neutral

1. Park vehicle on a level surface and turn engine off. Apply the parking brake, tip seat forward, and actuate pump lever (Fig. 58) to ensure assembly is properly seated and operating freely. Correct any discrepancy.

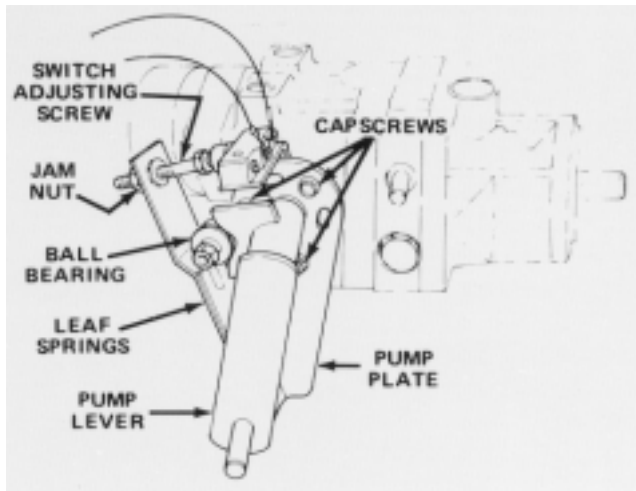

Figure 58

2. Block right front tire and both rear tires so vehicle cannot roll forward or backward.
3. Jack up frame so left front wheel is off the shop floor. Use a jack stand to support the frame.
4. Start engine and allow it to idle for 5 minutes to heat oil in transmission to operating temperature.
5. Release parking brake; then check left front wheel that is off shop floor. Wheel must not be rotating. If wheel is rotating, proceed to step 11 for an adjustment. If wheel is not rotating, proceed to step 13. Verify the adjustment with throttle in SLOW and FAST position.
6. Because the wheel is rotating, the pump plate must be adjusted. But before adjusting the pump plate, move throttle to SLOW. If wheel is rotating forward, loosen cap screws, and lightly tap bottom of pump plate counterclockwise (Fig. 58). By contrast, tap pump plate clockwise if wheel is rotating backward (Fig. 58). When

wheel stops rotating, tighten cap screws holding pump plate against side of transmission. Verify the adjustment with throttle in SLOW and FAST position.

7. Block right front tire and both rear tires so vehicle cannot roll forward or backward.
8. Jack up frame so left front wheel is off the shop floor. Use a jack stand to support the frame.
9. Start engine and allow it to idle for 5 minutes to heat oil in transmission to operating temperature.
10. Release parking brake; then check left front wheel that is off shop floor. Wheel must not be rotating. If wheel is rotating, proceed to step 11 for an adjustment. If wheel is not rotating, proceed to step 13. Verify the adjustment with throttle in SLOW and FAST position.
11. Because the wheel is rotating, the pump plate must be adjusted. But before adjusting the pump plate, move throttle to SLOW. If wheel is rotating forward, loosen cap screws, and lightly tap bottom of pump plate counterclockwise (Fig. 58). By contrast, tap pump plate clockwise if wheel is rotating backward (Fig. 58). When wheel stops rotating, tighten cap screws holding pump plate against side of transmission. Verify the adjustment with throttle in SLOW and FAST position.
12. Should front wheel continue to rotate, check for the following:
  - Ball bearing is loose or worn out (Fig. 58).
  - Plunger on interlock switch is sticking.
  - Loose or missing fasteners
  - Worn roll pin securing pump lever to transmission
  - Pump lever loose on control shaft. (Correct by applying Loc-tite 271 or 601 to shaft.)
  - Weak or damaged leaf springs (Fig. 58). Replace.
  - Internal transmission component malfunction. Contact your local Toro distributor for assistance.

13. Shut engine off.

14. Adjust traction control rod; refer to Adjusting the Traction Control Rod, page 37.

## Adjusting the Traction Interlock Switch

1. Adjust transmission for neutral; refer to Adjusting the Traction Drive for Neutral, page 42.
2. Actuate the pump lever (Fig. 58) to ensure all parts are operating freely and seated properly.
3. Loosen jam nut. Rotate switch adjusting screw (Fig. 58) until there is a gap between head of screw and switch button.



4. Rotate adjusting screw until it contacts the switch button. Continue to rotate the screw until the circuit is completed (switch “clicks”). After the switch clicks, rotate the adjusting screw an additional 1/2 turn. Tighten jam nut.

## Replacing the PTO Switch

1. Remove instrument cover and disconnect negative battery cable from battery.
2. Move PTO lever forward to ON position.
3. Remove boot from button end of PTO switch (Fig. 59). Retain boot for reinstallation. Separate switch wire connectors.



Figure 59

1. PTO switch

4. Remove front jam nut securing switch to mounting bracket and remove switch.
5. Install new PTO switch to mounting bracket. Adjust switch so it is depressed 1/2 in. (13 mm) when PTO lever is moved to OFF position. Tighten jam nuts to 75 in.-lb. Install boot to switch.

**Important** Switch threads will be damaged if jam nuts are over tightened.

6. Connect a continuity tester or ohm meter to switch connector. With PTO lever in the ON position the switch circuit **should not have** any continuity. If there is continuity, recheck switch installation. If there is no continuity, proceed to next step.
7. Move PTO lever to the OFF position. When PTO lever is in its normal, released position, the PTO switch **should have** continuity. If there is no continuity, recheck switch installation. If there is no continuity, proceed to next step.
8. Push switch connectors together.
9. Connect battery cable and install instrument cover.

## Adjusting PTO Drive Belt Tension

**Important** Check PTO belt tension initially after first 10 hours and 50 hours of operation and after every 100 hours of operation thereafter.

If belt begins to slip because it has stretched or because of worn linkage adjust as follows:

1. Unlatch and remove instrument cover.
2. Move PTO control lever to ON position.
3. Measure length of PTO spring between flat-washers (Fig. 60). There should be a spring length of 3-3/16 in. (81 mm).
4. To adjust, hold head of adjusting screw with wrench (under PTO actuating arm) and turn locknut (Fig. 60).
5. Move PTO lever to OFF position and install instrument cover.

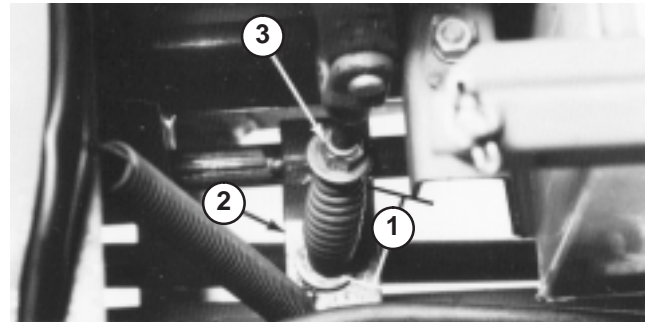
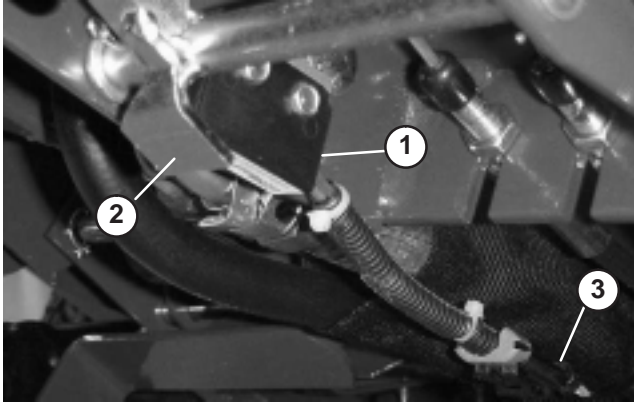

Figure 60

1. 3-3/16 in. (81 mm)
2. PTO actuating arm
3. Locknut

## Adjusting the Parking Brake Interlock Switch

1. Gap between parking brake shaft pivot paddle and bottom of interlock switch (Fig. 61) should be approximately 1/16" (Paddle must not contact switch).



**Figure 61**

1. Parking brake interlock switch
2. Parking brake shaft pivot paddle
3. Wire harness connector

2. To adjust gap, loosen switch mounting screws, adjust gap and tighten screws.
3. Disconnect switch pigtail connector from wire harness.
4. Pull up on parking brake lever and depress brake pedal to lock pedal into first click on latch.
5. Connect a continuity tester or ohm meter to switch harness connector. With parking brake engaged, the switch circuit **should not have** continuity. If there is continuity, recheck switch or switch installation.

## Adjusting the Tilt Steering Control

If steering wheel tilt control lever must be adjusted, proceed as follows:

1. Remove knob from parking brake and self tapping screws from steering column cover. Slide cover up steering shaft to expose pivot bracket (Fig. 62).

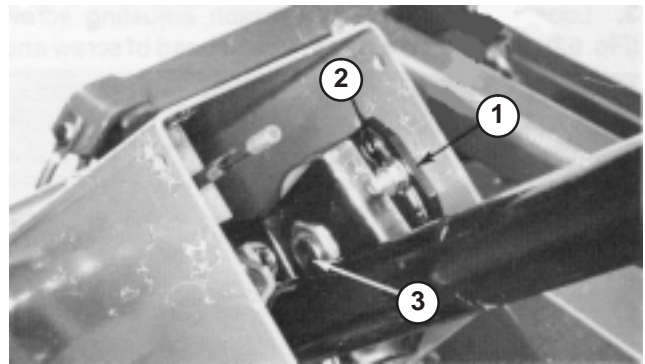

**Figure 62**

1. Pivot plate
2. Small nut
3. Large nut

2. Loosen small nut, rotate pivot bracket until it tightens large nut below (Fig. 62). Retighten small nut.
3. Reinstall steering column cover and parking brake knob.

## Adjusting Rear Wheel Toe-in (Models 30627 & 30631 only)

The rear wheels should not toe-in or toe-out when they are adjusted correctly. To check the rear wheel toe-in, measure the center-to-center distance at wheel hub height, in front and in back of the rear tires. If the wheels toe-in or toe-out, an adjustment is required.

1. Rotate the steering wheel so rear wheels are straight ahead.
2. Remove cotter pin and nut securing one tie rod ball joint to mounting bracket on axle and disconnect ball joint from axle (Fig. 63).

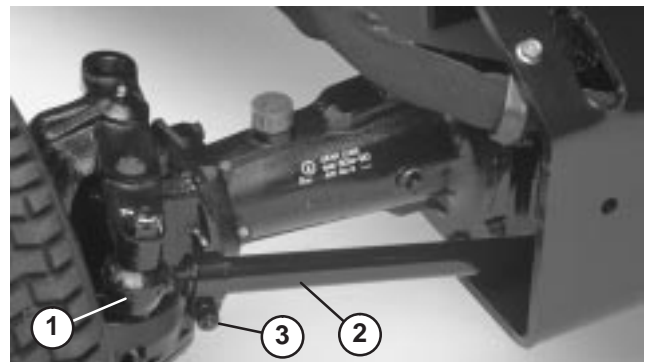

**Figure 63**

1. Ball joint
2. Tie rod
3. Tie rod clamp

- Loosen screw on tie rod clamp (Fig. 63). Rotate ball joint in or out to adjust length of tie rod.
- Reinstall ball joint to mounting bracket and check wheel toe-in.
- After attaining desired adjustment, tighten screw on tie rod clamp and re-secure ball joint to mounting bracket.

## Adjusting Rear Wheel Toe-in (Models 30626 & 30630 only)

The rear wheels should not toe-in or toe-out when they are adjusted correctly. To check the rear wheel toe-in, measure the center-to-center distance at wheel hub height, in front and in back of the rear tires. If the wheels toe-in or toe-out, an adjustment is required.

- Rotate the steering wheel so rear wheels are straight ahead.
- Loosen the jam nuts on both tie rods. Adjust both tie rods until center-to-center distance at front and back of rear wheels is the same (Fig. 64).
- When rear wheels are adjusted correctly, tighten jam nuts against tie rods.

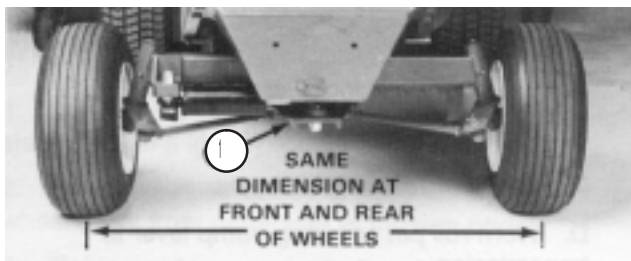

Figure 64

- Steering plate

## Adjusting the Rear Wheel Bearings (Models 30626 & 30630 only)

- Jack up rear of machine until wheel is off shop floor. Use jack stands or block the machine to prevent it from accidentally falling.
- Remove dust cap from end of wheel spindle. Also remove cotter pin securing retainer (Fig. 65).

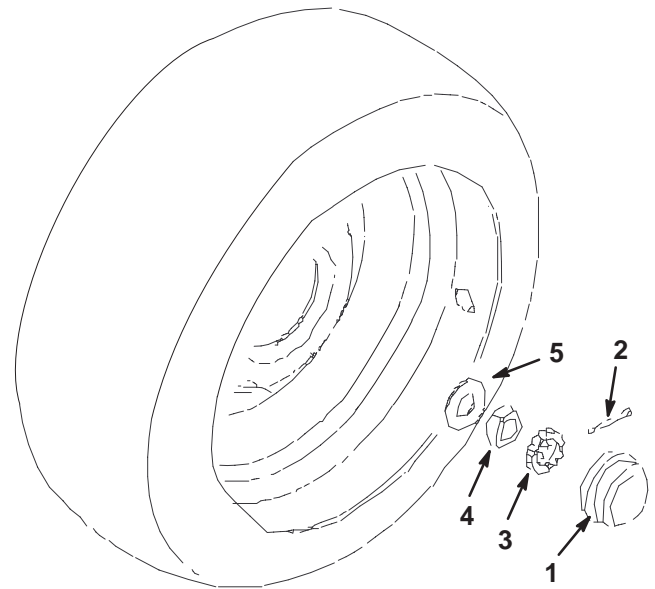

Figure 65

- Dust cup
  - Cotter pin
  - Nut retainer
  - Jam nut
  - Flatwasher
- Tighten the jam nut (Fig. 65) to approximately 75–100 in-lbs using a hand wrench.
  - Turn the wheel hub to seat the bearings.
  - Loosen the jam nut until it is away from the flatwasher and the wheel hub has end play.
  - Tighten the jam nut to 15–20 in-lbs while rotating the the wheel hub.
  - Place the nut retainer over the jam nut. If the cotter pin hole is not aligned with the retainer slot, remove the retainer nut and reorientate until alignment occurs.
  - Insert cotter pin. The wheel hub must not have any free play.
  - Install dust cap on end of wheel spindle.
  - Remove jack stands and lower machine to shop floor.

## Adjusting the Brakes

Adjust the service brakes when there is more than 1 in. (25 mm) of “free travel” of the turn pedals, or when the brakes do not work effectively. Free travel is the distance the brake pedal moves before braking resistance is felt.

The brakes should only need adjusting after considerable use. These periodic adjustments can be performed where the brake cables connect to the brake pedal mount. When the cables are no longer adjustable, the star nut on the inside of the brake drum must be adjusted to move the brake shoes outward. However, the brake cables must be adjusted again to compensate for this adjustment.

1. To reduce free travel of turn pedals—tighten the brakes—loosen front nut on threaded end of brake cable (Fig. 66). Then tighten rear nut to move cable backward until turn pedals have 1/2 to 1 in. (13 to 25 mm) of free travel. Tighten front nut after brakes are adjusted correctly.

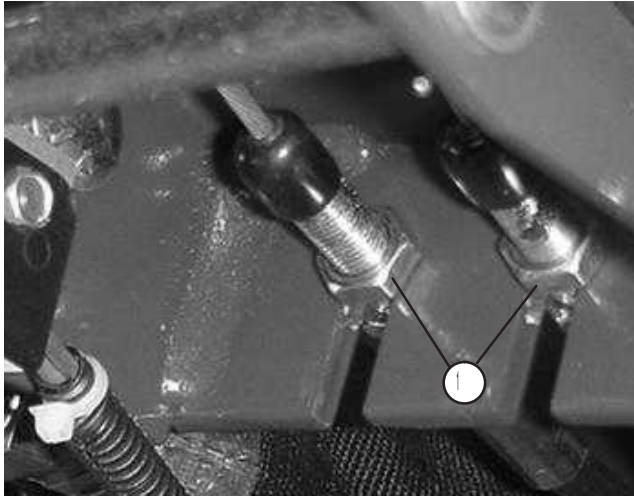

**Figure 66**

1. Jam nuts

2. When adjustment of brake cable cannot get free travel within 1/2 to 1 in. (13 to 25 mm), the star nut inside the brake drum must be adjusted. However, before adjusting the star nut, loosen brake cable nuts to prevent unnecessary strain on the cables.
3. Loosen five wheel nuts holding wheel and tire assembly on wheel studs.
4. Jack up machine until front wheel is off the shop floor. Use jack stands or block the machine to prevent it from falling accidentally.
5. Remove wheel nuts and slide wheel and tire assembly off studs. Rotate brake drum until adjusting slot is at bottom and centered over star nut that adjusts brake shoes (Fig. 67).

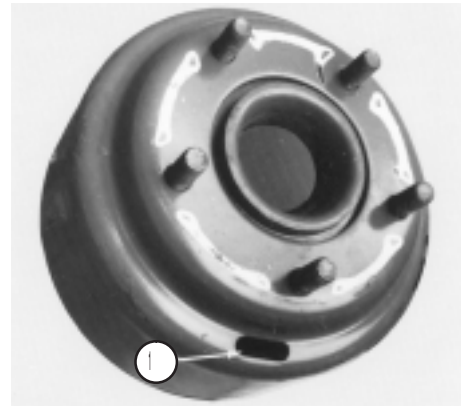

**Figure 67**

1. Slot

6. Using a brake adjusting tool or screwdriver, rotate star nut (Fig. 67) down until brake drum (Fig. 68) locks because of outward pressure of brake shoes (Fig. 68).

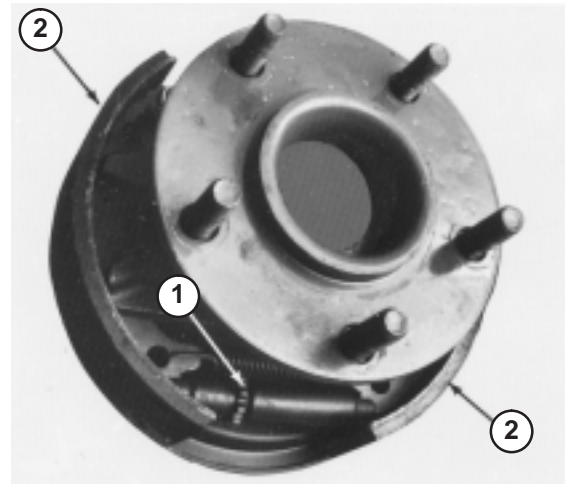

**Figure 68**

1. Star nut
2. Brake shoes

7. Loosen star nut about 12 to 15 notches or until brake drum rotates freely.
8. Install wheel and tire assembly on studs with five wheel nuts. Tighten nuts to 45-55 ft-lb (61-75 N·m).
9. Remove jack stands or blocking and lower machine to the shop floor.
10. Adjust the brake cables using step 1.



## Replacing the Hydraulic Fluid Filter

The hydraulic fluid filter keeps the hydraulic system relatively free of contaminants and must be serviced at regular intervals. **Initially, change filter after first ten hours of engine operation, and thereafter, after every 200 hours of operation or yearly, whichever comes first.** Use Toro oil filter, Part No. 23-9740, as a replacement.

1. Clean area where hydraulic fluid filter mounts. Remove filter from base (Fig. 69) and clean filter mounting surface.



Figure 69

1. Hydraulic oil filter
- 
2. Lubricate filter gasket with proper type of hydraulic fluid. Then fill filter using the same hydraulic fluid.
  3. Install filter by hand until gasket contacts mounting head. Then rotate an additional 1/2 turn.
  4. Start engine and check for hydraulic fluid leaks. Allow engine to run for about two minutes so any air in the system is purged (removed).
  5. Shut engine off and check level of hydraulic system; refer to Checking the Hydraulic System Oil, page 26.

## Changing the Hydraulic System Fluid

The hydraulic system fluid must be changed after every 1000 hours of normal operation or every two years, whichever comes first.

The following list is not assumed to be all-inclusive. Hydraulic fluids produced by other manufacturers may be used if they can cross reference to find an equivalent to the products listed. Toro will not assume responsibility for damage caused by improper substitutions, so use only products from reputable manufacturers who will stand behind their recommendation.

### Universal Tractor Hydraulic Fluid

Mobil	Mobil Fluid 424
Amoco	1000 Fluid
Chevron	Tractor Hydraulic Fluid
Conoco	Power-Tran 3
Exxon	Torque Fluid
Pennzoil	Hydra-Tranz
Shell	Donax TD
Texaco	TDH

**Note:** Many hydraulic fluids are almost colorless, making it difficult to spot leaks. A red dye additive for the hydraulic system oil is available in 2/3 oz. (20 ml) bottles. One bottle is sufficient for 4–6 gal (15–22 l) of hydraulic oil. Order part no.44–2500 from your authorized Toro distributor.

1. Start engine, park machine on a level surface, lower implement to the shop floor, set the parking brake, and shut engine off. Block the two rear wheels.
2. Jack up both sides of front axle and support it with jack stands.
3. Clean area around hydraulic fluid filter and remove filter.
4. Remove drain plug from fitting between axle housing and oil filter and allow fluid to flow into drain pan (Fig. 70).

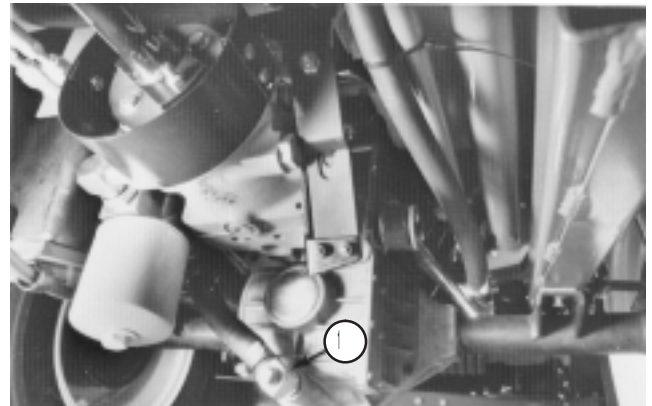
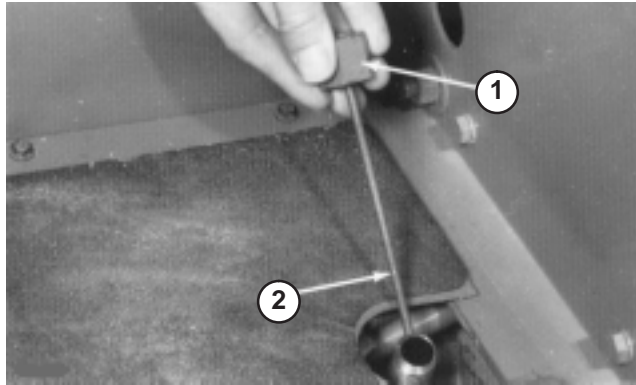

Figure 70

1. Drain plug
- 
5. Install new filter; refer to steps 1–2 in Replacing Hydraulic Oil Filter, for proper procedures.
  6. Install drain plug in fitting between axle housing and filter (Fig. 70).
  7. Remove dipstick from axle filler tube (Fig. 71) and fill axle to proper level with correct type of hydraulic fluid; refer to table above.

8. Start and run the engine at idle speed for about two minutes and turn the steering wheel lock to lock to purge air trapped in the system. Shut the engine off.
9. Leave machine set for two additional minutes, then remove dipstick and check fluid level in axle (Fig. 71). If level is low, add fluid until level matches groove in dipstick (Fig. 71). If level is too high, remove drain plug (Fig. 70) and drain fluid until level matches groove in dipstick.



**Figure 71**

1. Dipstick
2. Groove

## Changing Rear Axle Lubricant

After every 400 hours of operation, the oil in the rear axle must be changed.

1. Position machine on a level surface.
2. Clean area around the drain plugs (Fig. 72).
3. Remove plug allowing oil to drain into drain pans.
4. **After oil is drained, apply thread locking compound on drain plug threads and reinstall in axle.**
5. Fill axle with lubricant; refer to Check Rear Axle.

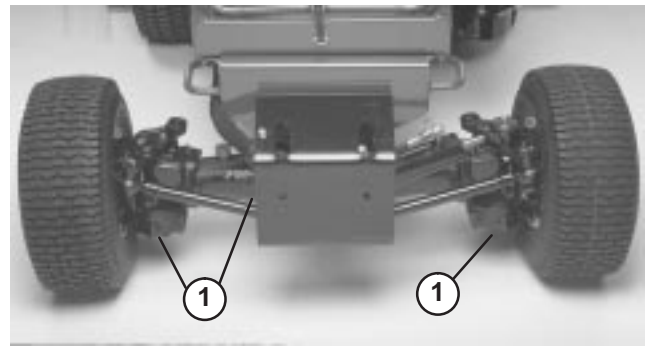

**Figure 72**

1. Drain plugs

## Changing Bidirectional Clutch Lubricant

(Models 30627 & 30631 only)

After every 400 hours of operation, the oil in the bidirectional clutch must be changed.

1. Position the machine on a level surface.
2. Clean area around check plug on bidirectional clutch.
3. Rotate clutch so check plug is positioned downward (Fig. 73).

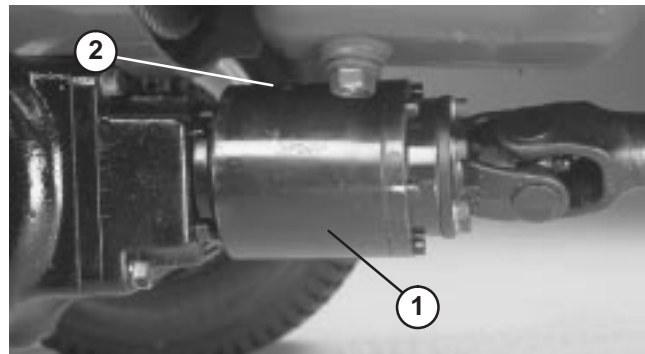

**Figure 73**

1. Bidirectional clutch
2. Check plug

4. Remove check plug allowing all lubricant to flow into drain pan.
5. Rotate clutch so check plug is positioned at 4 O'clock.



6. Add Mobil Fluid 424 until lubricant level is up to hole in clutch. Clutch should be approximately 1/3 full.
7. Install check plug.

**Note:** Do not use engine oil (i.e. 10W30) in bidirectional clutch. Anti-wear and extreme pressure additives will cause undesirable clutch performance.

## Fuses

The fuse block is located below control panel.

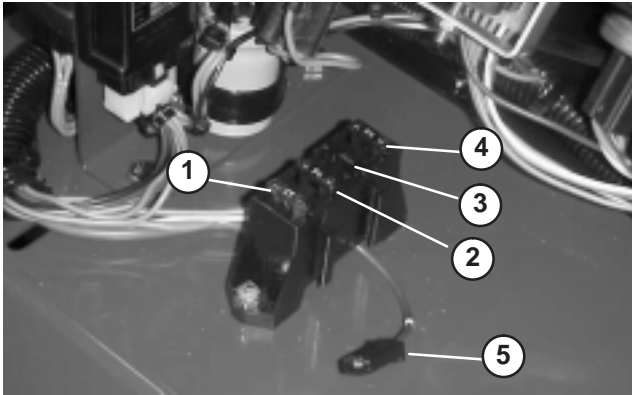

**Figure 74**

- |                       |                        |
|-----------------------|------------------------|
| 1. 15 Amp. Fuse       | 4. 7.5 Amp. Fuse       |
| 2. 7.5 Amp. Fuse      | 5. Accessory connector |
| 3. Open (Accessories) |                        |

## Servicing the Battery



### Warning



**Battery posts, terminals, and related accessories contain lead and lead compounds, chemicals known to the State of California to cause cancer and reproductive harm. Wash hands after handling.**

**Important** Before welding on the machine, disconnect ground cable from the battery to prevent damage to the electrical system.

**Note:** Check battery condition weekly or after every 50 hours of operation. Keep terminals and entire battery case clean because a dirty battery will discharge slowly. To clean the battery, wash the entire case with solution of baking soda and water. Rinse with clear water. Coat the battery posts and cable connectors with Grafo 112X (skin-over) grease (Toro Part No. 505-47) or petroleum jelly to prevent corrosion.

# Hydraulic Schematic

(Models 30627 & 30631 only)

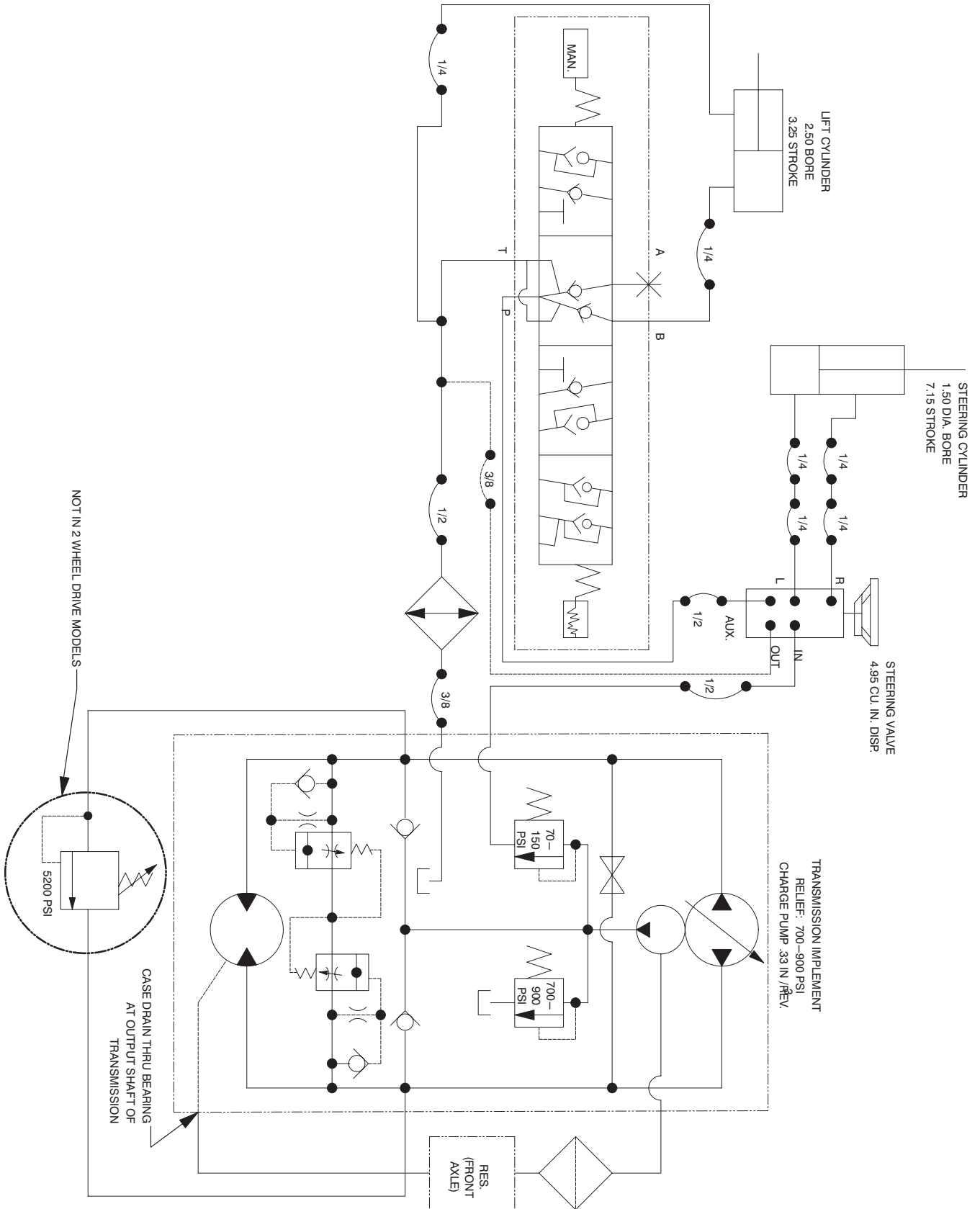

# Hydraulic Schematic

(Models 30626 & 30630 only)

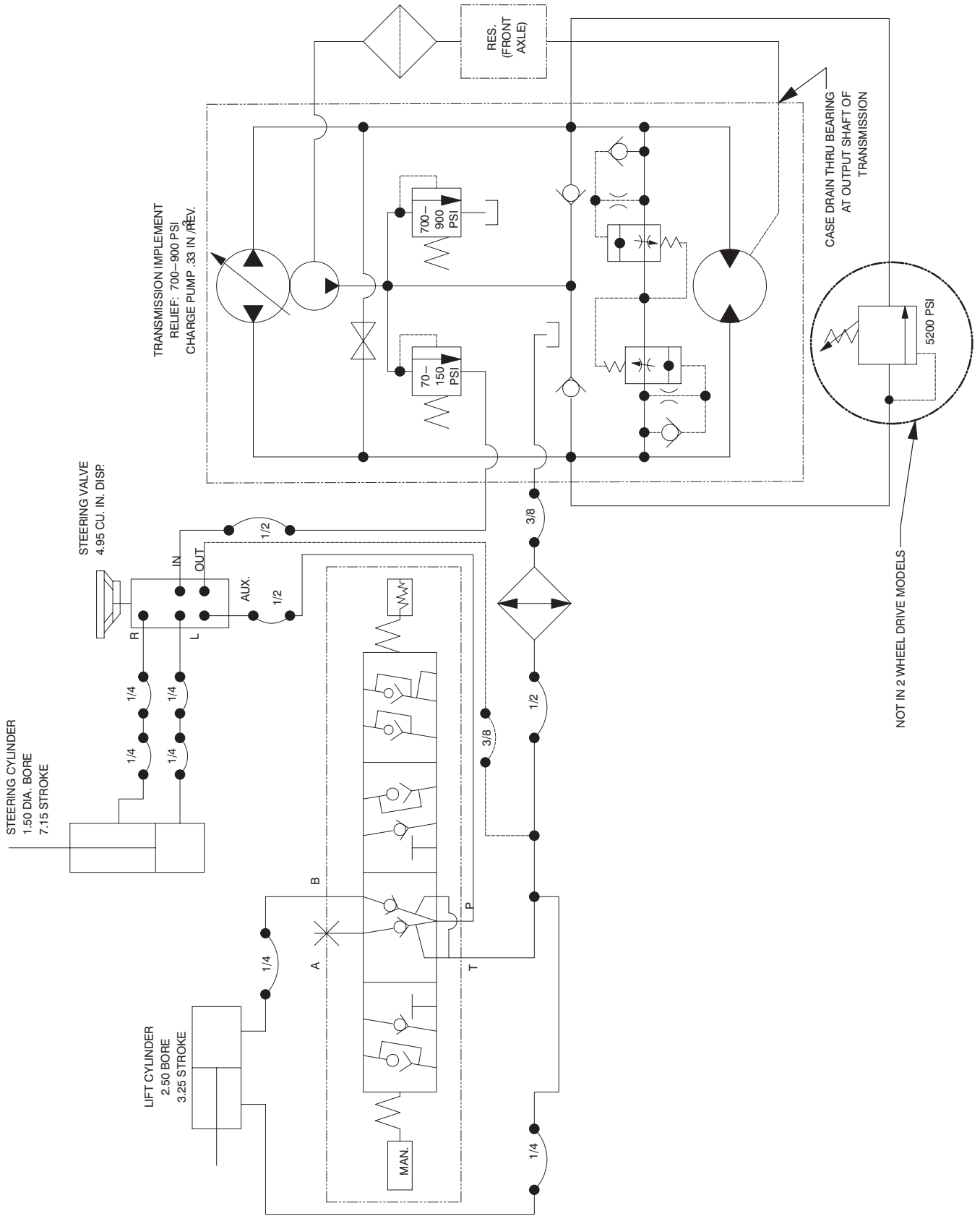

# Electrical Schematic

(Models 30627 & 30631 only)

KEY TO WIRE COLORS

BK = BLACK    GN = GREEN  
 BR = BROWN   GY = GRAY  
 BU = BLUE  
 R = RED  
 Y = YELLOW  
 W = WHITE  
 T = TAN

OR = ORANGE  
 PK = PINK  
 VO = VIOLET

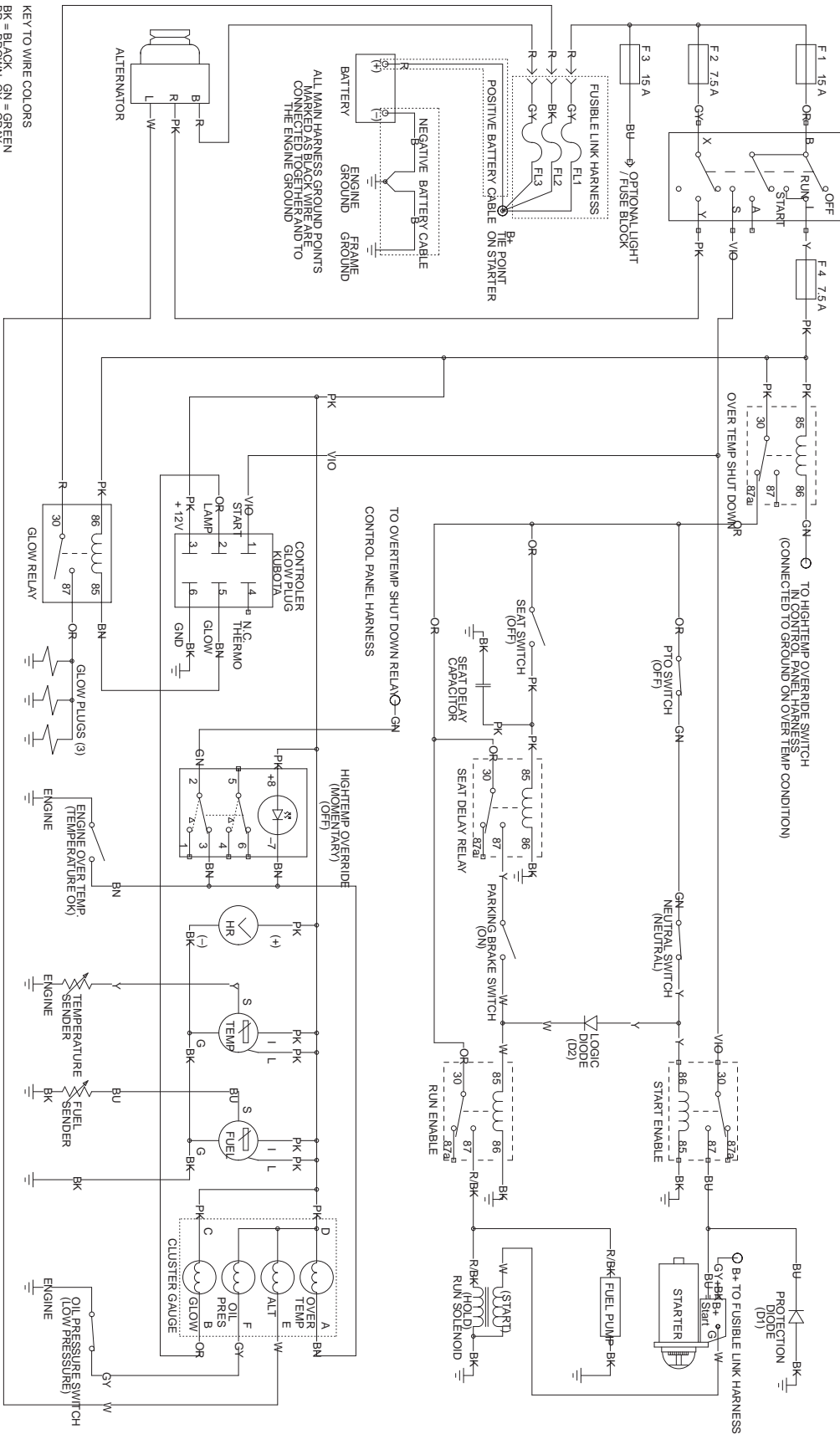

# Electrical Schematic

(Models 30626 & 30630 only)

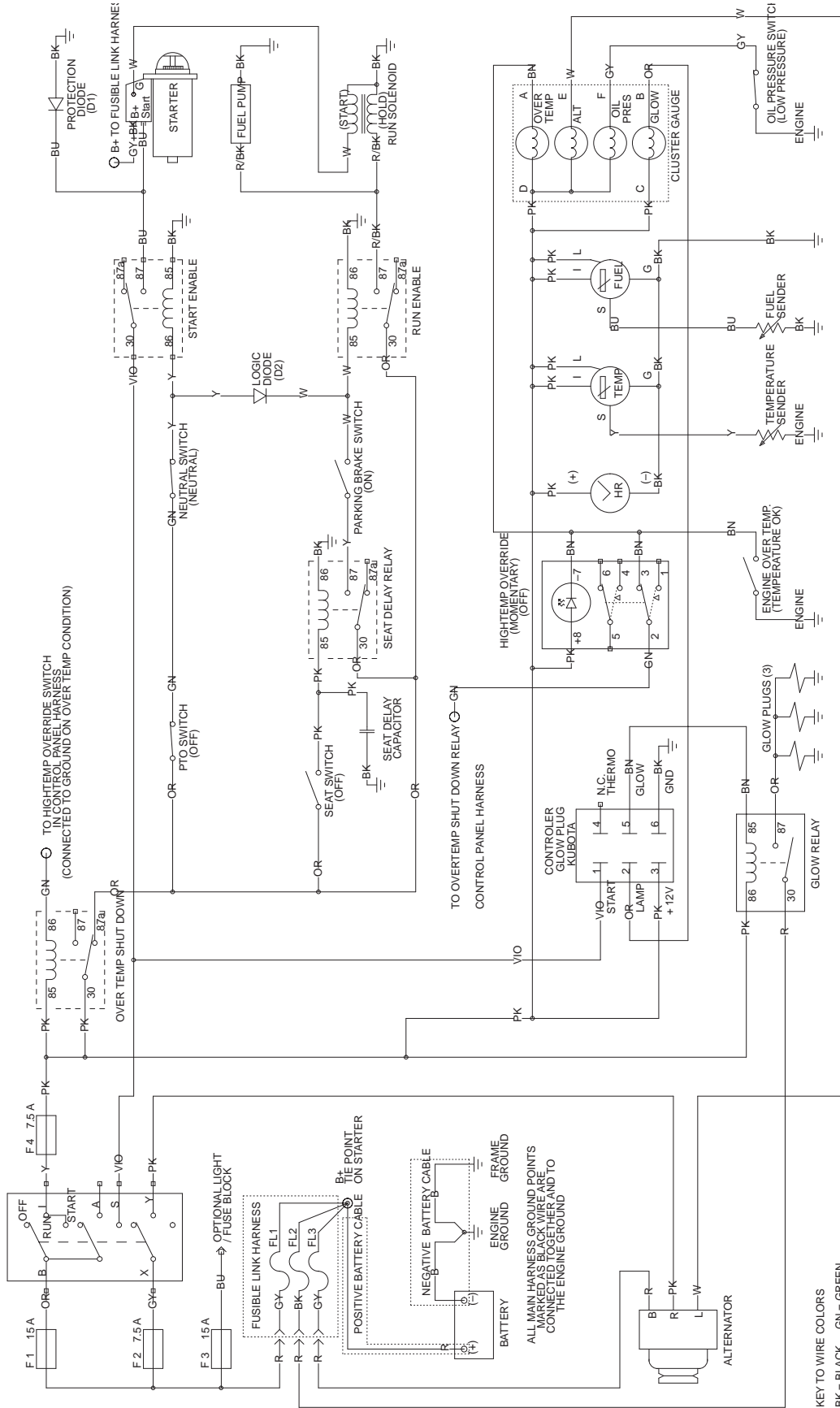

# Seasonal Storage

## Traction Unit

1. Thoroughly clean the traction unit, cutting unit and the engine, paying special attention to these areas:
  - radiator screen
  - underneath the cutting unit
  - under the cutting unit belt covers
  - counterbalance springs
  - P.T.O. Shaft Assembly
  - all grease fittings and pivot points
2. Check the tire pressure. Inflate all traction unit tires to 21 psi (145 kPa).
3. Remove, sharpen, and balance the cutting unit's blades. Reinstall the blades and torque the blade fasteners to specifications.
4. Check all fasteners for looseness; tighten as necessary.
5. Grease or oil all grease fittings and pivot points. Wipe up any excess lubricant.
6. Ensure that the P.T.O. belt remains in the disengaged position so that the P.T.O. belt does not take a "set."
7. Lightly sand and use touch-up paint on painted areas that are scratched, chipped, or rusted. Repair any dents in the metal body.
8. Service the battery and cables as follows:
  - A. Remove the battery terminals from the battery posts.
  - B. Clean the battery, terminals, and posts with a wire brush and baking soda solution.
  - C. Coat the cable terminals and battery posts with Grafo 112X skin-over grease (Toro Part No. 505-47) or petroleum jelly to prevent corrosion.
  - D. Slowly recharge the battery every 60 days for 24 hours to prevent lead sulfation of the battery.

## Engine

1. Drain the engine oil from the oil pan and replace the drain plug.
2. Remove and discard the oil filter. Install a new oil filter.
3. Remove fill cap and add 4 quarts (3.8 l) of SAE 10W-30 CD, CE, CF, CF-4 or CG-4 classification oil until level reaches FULL mark on dipstick. DO NOT OVERFILL.
4. Start the engine and run at idle speed for approximately two minutes.
5. Stop the engine.
6. Thoroughly drain all fuel from the fuel tank, lines, fuel pump filter, and the fuel filter/water separator assembly.
7. Flush the fuel tank with fresh, clean diesel fuel.
8. Secure all fuel system fittings.
9. Thoroughly clean and service the air cleaner assembly.
10. Seal the air cleaner inlet and the exhaust outlet with weatherproof tape.
11. Check anti-freeze protection and add as needed for expected minimum temperature in your area.







# The Toro General Commercial Products Warranty

## A Two-Year Limited Warranty

### Conditions and Products Covered

The Toro Company and its affiliate, Toro Warranty Company, pursuant to an agreement between them, jointly warrant your 1996 or newer Toro Commercial Product ("Product") purchased after January 1, 1997, to be free from defects in materials or workmanship for two years or 1500 operational hours\*, whichever occurs first. Where a warrantable condition exists, we will repair the Product at no cost to you including diagnosis, labor, parts, and transportation. This warranty begins on the date the Product is delivered to the original retail purchaser.

\* Product equipped with hour meter

### Instructions for Obtaining Warranty Service

You are responsible for notifying the Commercial Products Distributor or Authorized Commercial Products Dealer from whom you purchased the Product as soon as you believe a warrantable condition exists.

If you need help locating a Commercial Products Distributor or Authorized Dealer, or if you have questions regarding your warranty rights or responsibilities, you may contact us at:

Toro Commercial Products Service Department  
Toro Warranty Company  
8111 Lyndale Avenue South  
Bloomington, MN 55420-1196  
952-888-8801 or 800-982-2740  
E-mail: commercial.service@toro.com

### Owner Responsibilities

As the Product owner, you are responsible for required maintenance and adjustments stated in your operator's manual. Failure to perform required maintenance and adjustments can be grounds for disallowing a warranty claim.

### Items and Conditions Not Covered

Not all product failures or malfunctions that occur during the warranty period are defects in materials or workmanship. This express warranty does not cover the following:

- Product failures which result from the use of non-Toro replacement parts, or from installation and use of add-on, modified, or unapproved accessories
- Product failures which result from failure to perform required maintenance and/or adjustments
- Product failures which result from operating the Product in an abusive, negligent or reckless manner
- Parts subject to consumption through use unless found to be defective. Examples of parts which are consumed, or used up, during normal Product operation include, but are not limited to, blades, reels, bedknives, tines, spark plugs, castor wheels, tires, filters, belts, etc.

### Countries Other than the United States or Canada

Customers who have purchased Toro products exported from the United States or Canada should contact their Toro Distributor (Dealer) to obtain guarantee policies for your country, province, or state. If for any reason you are dissatisfied with your Distributor's service or have difficulty obtaining guarantee information, contact the Toro importer. If all other remedies fail, you may contact us at Toro Warranty Company.

- Failures caused by outside influence. Items considered to be outside influence include, but are not limited to, weather, storage practices, contamination, use of unapproved coolants, lubricants, additives, or chemicals, etc.
- Normal "wear and tear" items. Normal "wear and tear" includes, but is not limited to, damage to seats due to wear or abrasion, worn painted surfaces, scratched decals or windows, etc.

### Parts

Parts scheduled for replacement as required maintenance are warranted for the period of time up to the scheduled replacement time for that part.

Parts replaced under this warranty become the property of Toro. Toro will make the final decision whether to repair any existing part or assembly or replace it. Toro may use factory remanufactured parts rather than new parts for some warranty repairs.

### General Conditions

Repair by an Authorized Toro Distributor or Dealer is your sole remedy under this warranty.

**Neither The Toro Company nor Toro Warranty Company is liable for indirect, incidental or consequential damages in connection with the use of the Toro Products covered by this warranty, including any cost or expense of providing substitute equipment or service during reasonable periods of malfunction or non-use pending completion of repairs under this warranty. Except for the Emissions warranty referenced below, if applicable, there is no other express warranty. All implied warranties of merchantability and fitness for use are limited to the duration of this express warranty.**

Some states do not allow exclusions of incidental or consequential damages, or limitations on how long an implied warranty lasts, so the above exclusions and limitations may not apply to you.

This warranty gives you specific legal rights, and you may also have other rights which vary from state to state.

**Note regarding engine warranty:** The Emissions Control System on your Product may be covered by a separate warranty meeting requirements established by the U.S. Environmental Protection Agency (EPA) and/or the California Air Resources Board (CARB). The hour limitations set forth above do not apply to the Emissions Control System Warranty. Refer to the Engine Emission Control Warranty Statement printed in your operator's manual or contained in the engine manufacturer's documentation for details.