



Count on it.

Parts Catalog

ProCore® 864

Aerator

Model No. 09715—Serial No. 412000000 and Up



Ordering Replacement Parts

To order replacement parts, please supply the part number, the quantity, and the description of each part desired.

Understanding Reference Numbers

Each identified part in an illustration has a reference number. The reference number for a part also appears in the parts list, along with other information about the part.

This catalog uses two special reference number formats, one to indicate parts in a service assembly and another to indicate the quantity of a given part in an illustration.

Service Assembly Reference Numbers

Parts in service assemblies have reference numbers in the form a:b. The a represents the reference number of the entire service assembly and the b represents a sequential number unique to each part within the service assembly.

For example, a wheel assembly might be identified by reference number 6, the tire by 6:1, the valve by 6:2, and the wheel by 6:3. When you order the assembly identified by reference number 6, you receive all parts identified by reference numbers 6:1, 6:2, and 6:3. However, you may also order any part individually. Reference numbers of this type appear in illustration and in parts lists.

Reference Numbers Indicating Quantity

In an illustration, if a reference number indicates more than one part, the reference number has the form nX y. The n represents the quantity of the part, the X is the multiplication symbol, and the y represents the reference number.

For example, in an illustration, the reference number 2X 37 means that two of the parts identified by reference number 37 are indicated.

Contents

Frame Assembly.....	4
Gearbox and Driveline Assembly.....	5
Shielded Drive Shaft Assembly No. 110-4283.....	6
Gearbox Assembly No. 110-4565.....	7
Drive Shaft Assembly No. 110-4585.....	8
Roller and Scraper Assembly.....	9
Right Hand Belt Drive Assembly.....	10
H-Frame Assembly.....	11
Depth Control Assembly No. 115-2844.....	12
No. 1 and No. 2 Crankarm Assembly.....	13
No. 3 and No. 4 Crankarm Assembly.....	14
No. 5 and No. 6 Crankarm Assembly.....	15
No. 7 and No. 8 Crankarm Assembly.....	16
Roto-Link Damper Assembly.....	17
Turf Guard Assembly.....	18
Front Cover Assembly.....	19
Rear Cover Assembly.....	20
Storage Stand Assembly.....	21
Cover Latch Assembly.....	22
Attachments and Accessories.....	23

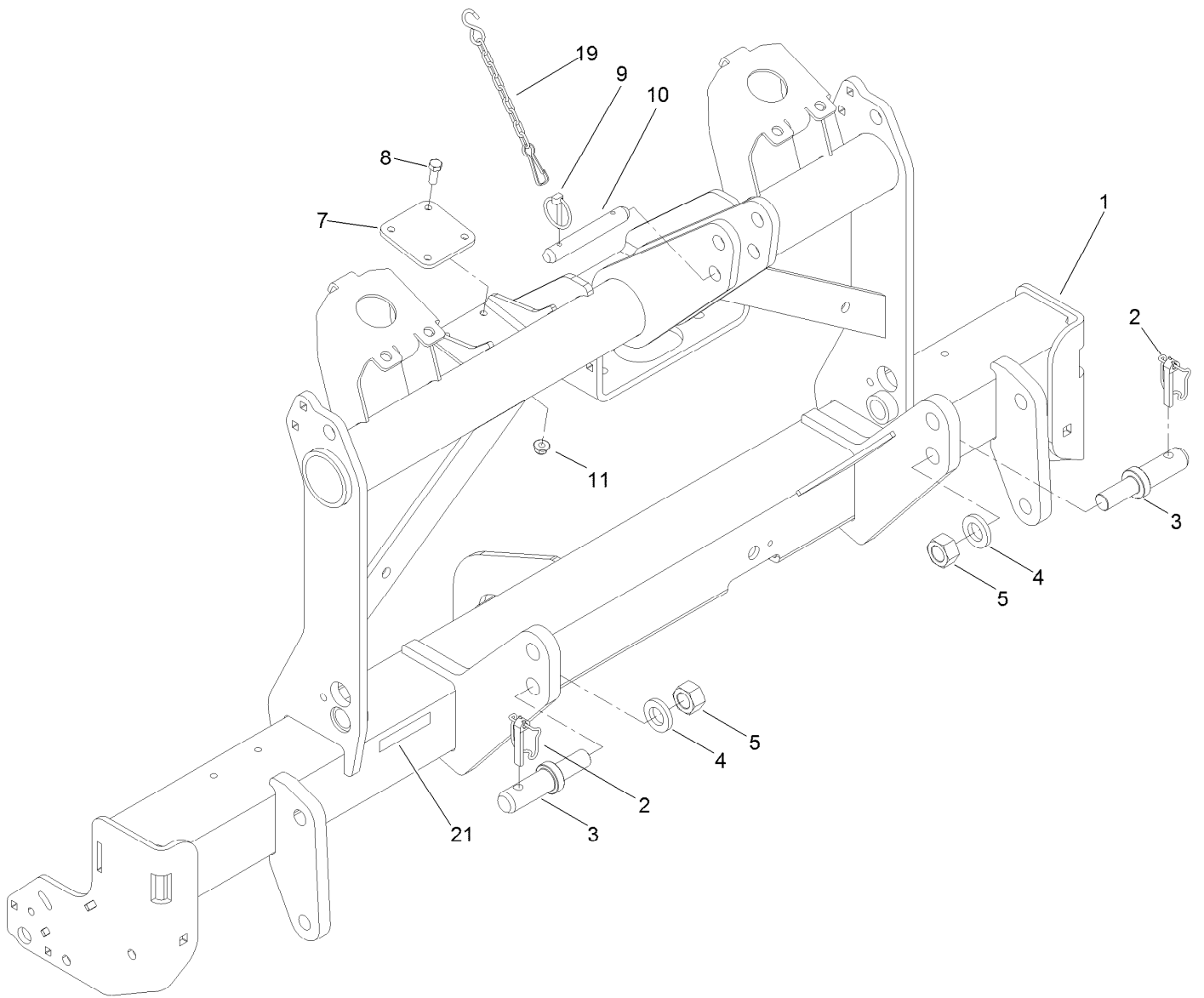

Frame Assembly

Ref.	Part Number	Qty.	Description
1	110-4221-01	1	Frame-Hitch, 3-Pt
2	3290-384	2	Pin-Lynch
3	110-4314	2	Pin-Link, Cat 2
3	110-4315	2	Pin-Link, Cat 1
4	120-5576	2	Washer-Hardened
5	3219-18	2	Nut-Hex
7	110-4440	1	Pad
8	3234-17	4	Screw-HHF
9	92-1298	2	Pin-Lynch
10	92-1233	1	Pin-Clevis
11	104-8300	4	Nut-HF, NI
19	110-4679	1	Chain-Storage, Driveline
21	133-8061	1	Decal-Warning

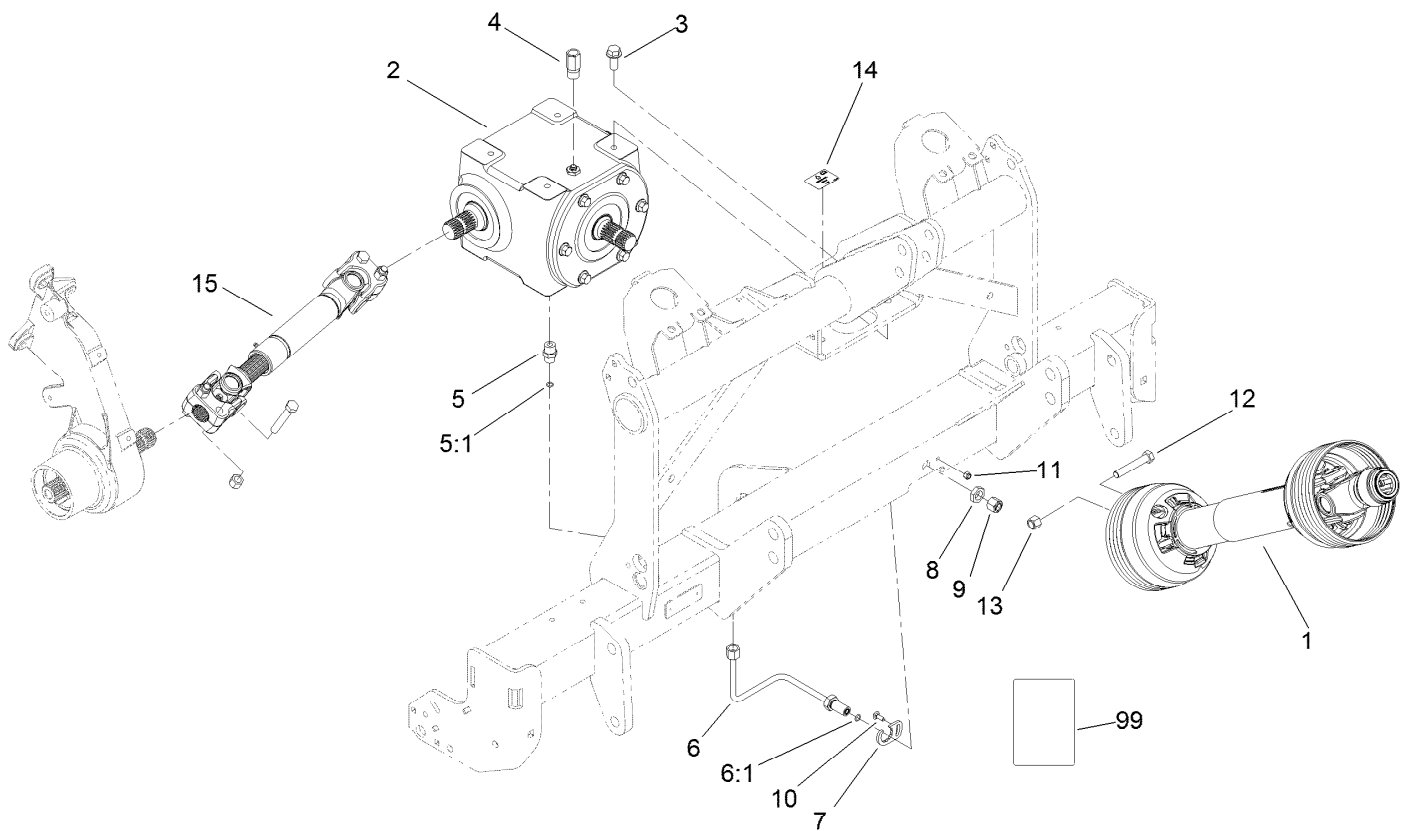

Gearbox and Driveline Assembly

<i>Ref.</i>	<i>Part Number</i>	<i>Qty.</i>	<i>Description</i>	<i>Ref.</i>	<i>Part Number</i>	<i>Qty.</i>	<i>Description</i>
1	110-4283	1	Shielded Driveshaft ASM	9	340-117	1	Cap
2	110-4565	1	Gearbox-T	10	3229-1	1	Screw-CARR
3	3234-38	4	Screw-HHF	11	3296-42	1	Nut-Lock, NI
4	110-4590	1	Fitting-Reducer	12	325-12	5	Screw-HH
5	340-124	1	Adapter	13	3296-23	5	Nut-Lock, NI
5:1	237-22	1	O-Ring	14	110-4665	1	Decal-Service, Oil
6	110-4335	1	Tube ASM	15	110-4585	1	Drive Shaft ASM
6:1	237-22	1	O-Ring	99	138-9038	1	Decal-Danger, Entanglement
7	110-4553	1	Keeper-Hardline				
8	340-70	1	Nut-Lock				

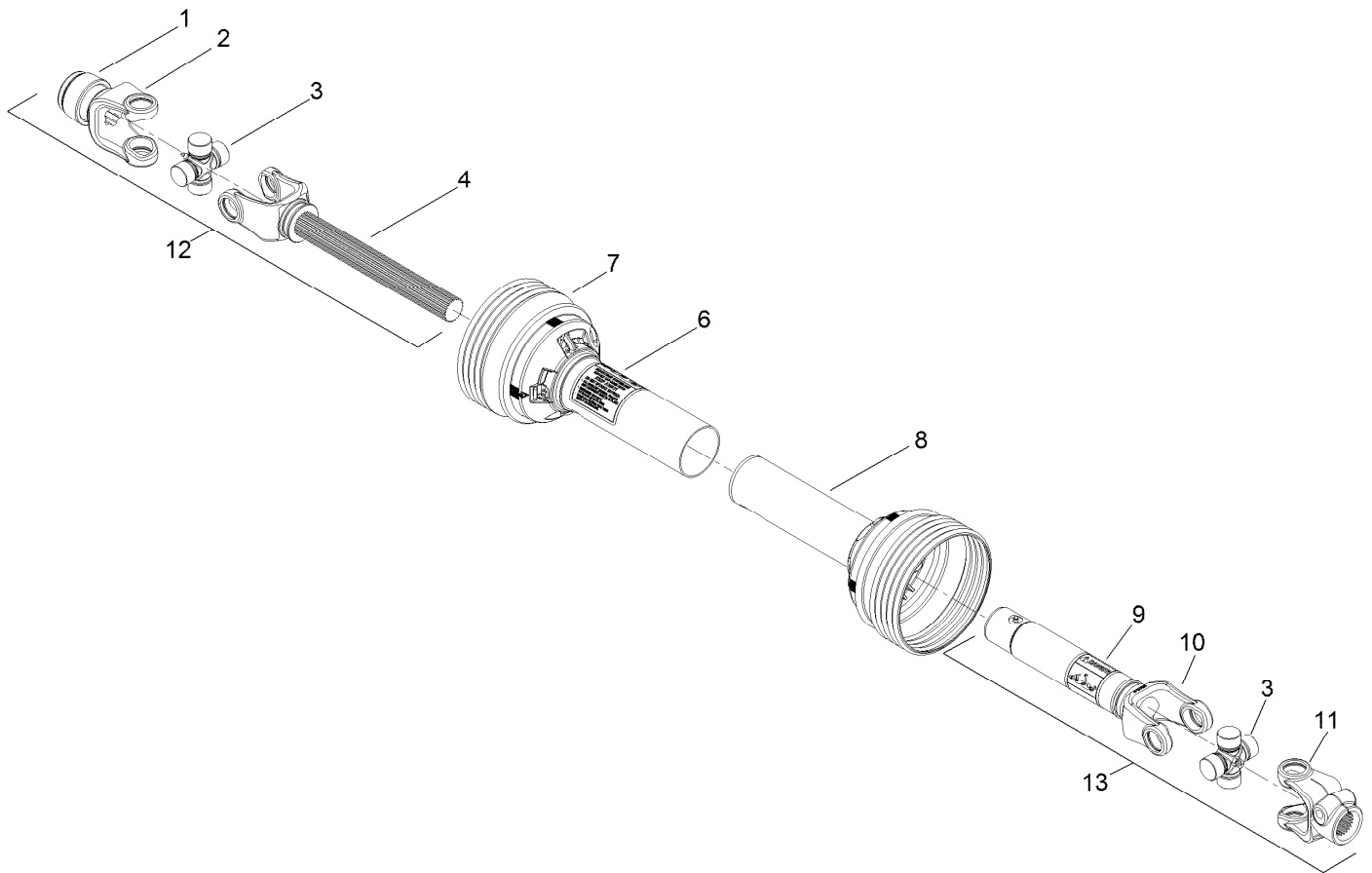

Shielded Drive Shaft Assembly No. 110-4283

<i>Ref.</i>	<i>Part Number</i>	<i>Qty.</i>	<i>Description</i>
1	93-4636	1	Auto-Lok Repair Kit
2		1	Safety Slide Lock Yoke ASM ■
3	110-4635	2	Cross And Bearing Kit
4		1	Yoke And Shaft ASM ■
5	110-4636	2	Guard Repair Kit ●
6	92-1581	1	Decal-Safety
7	110-4637	1	Guard-Outer
8	110-4638	1	Guard-Inner
9	92-1582	1	Decal-Safety
10		1	Yoke And Tube ASM ■
11		1	Yoke ■
12	110-4633	1	Joint And Shaft Half ASM
13	110-4634	1	Joint And Tube Half ASM

● Not illustrated

■ Not serviced separately

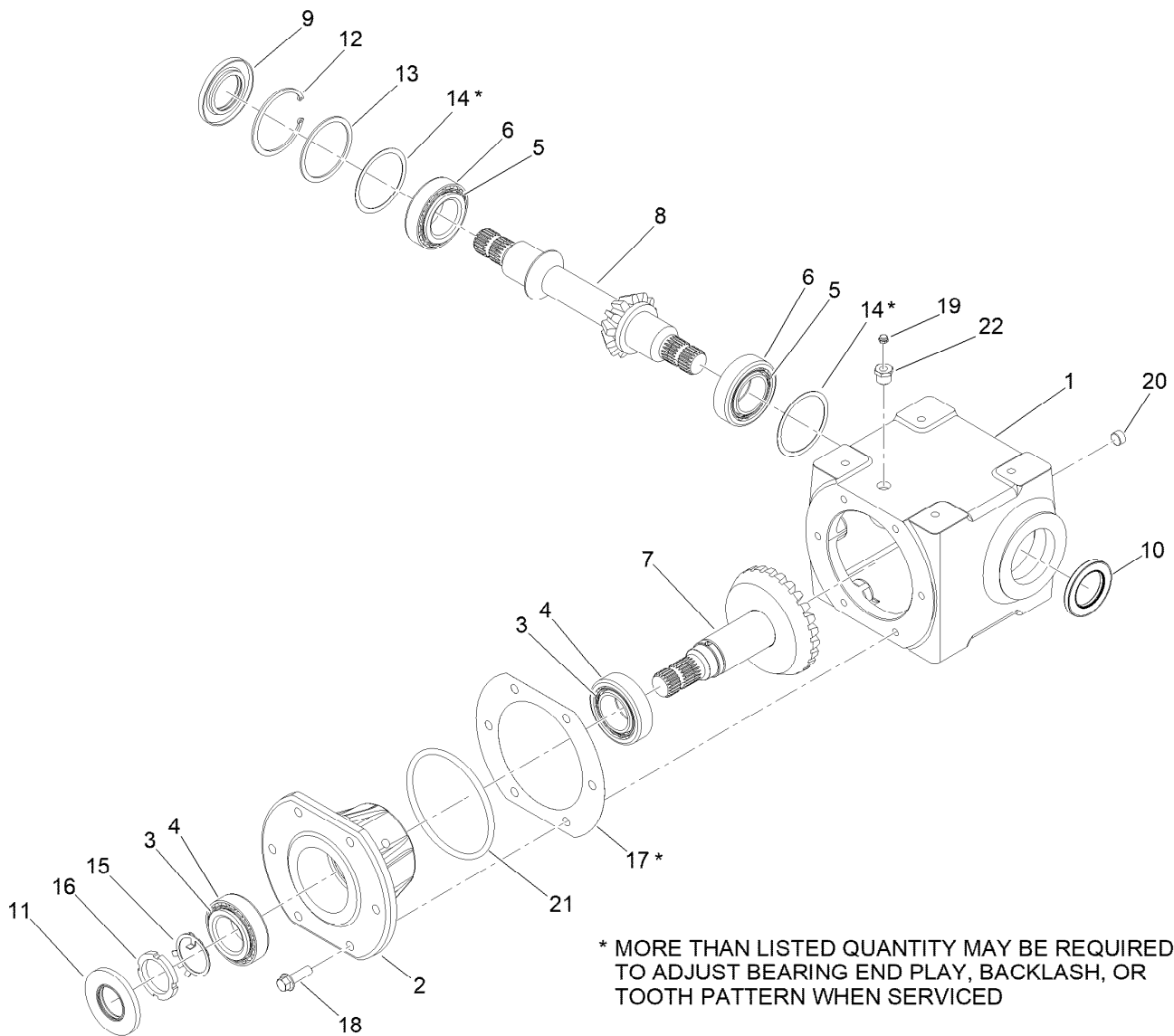

Gearbox Assembly No. 110-4565

<i>Ref.</i>	<i>Part Number</i>	<i>Qty.</i>	<i>Description</i>	<i>Ref.</i>	<i>Part Number</i>	<i>Qty.</i>	<i>Description</i>
1	110-4644	1	Housing	12	110-4655	1	Ring-Retaining
2	110-4645	1	Quill	13	110-4656	1	Shim-Hard
3	110-4646	2	Cone-Bearing	14	110-4657	2	Shim-Soft
4	110-4647	2	Cup-Bearing	15	110-4658	1	Shim-Retaining
5	110-4648	2	Cone-Bearing	16	110-4659	1	Nut-Lock
6	110-4649	2	Cup-Bearing	17	110-4660	1	Gasket
7	110-4650	1	Gear And Shaft ASM	18	33106-045	6	Screw-HHF
8	110-4651	1	Shaft-Cross	19	110-4661	1	Vent-Relief
9	110-4652	1	Seal-Viton	20	281-3	1	Plug-Pipe, SQH
10	110-4653	1	Seal-Viton	21	110-4662	1	O-Ring
11	110-4654	1	Seal-Viton	22	140-2251	1	Adapter

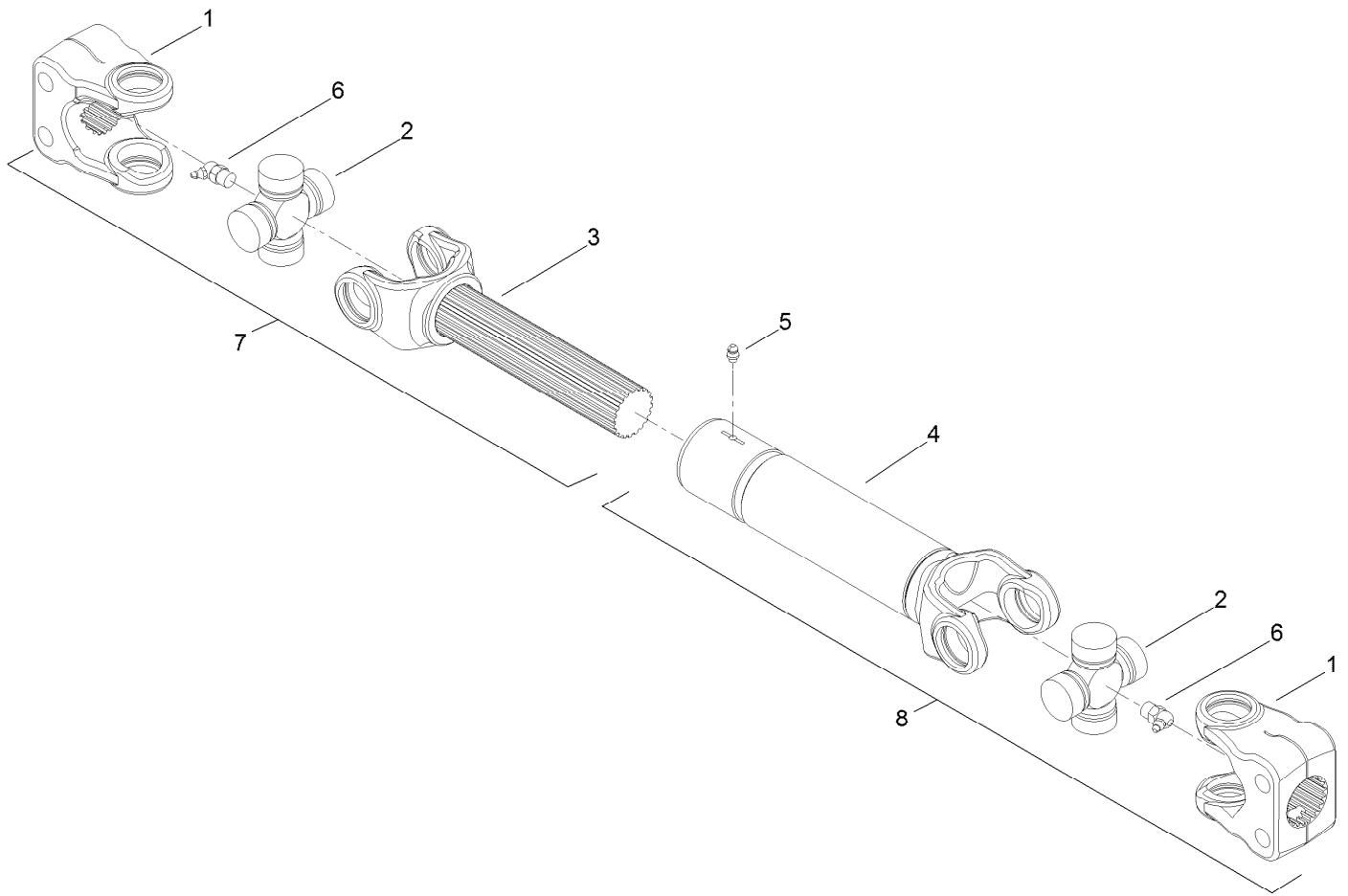

Drive Shaft Assembly No. 110-4585

Ref.	Part Number	Qty.	Description
1		1	Yoke ●
2	110-4641	2	Cross And Bearing Kit
3		1	Yoke And Shaft ASM ●
4		1	Yoke And Tube ASM ●
5		1	Zerk-Grease ●
6		2	Zerk-Grease ●
7	110-4639	1	Joint And Shaft Half ASM
8	110-4640	1	Joint And Tube Half ASM

● Not serviced separately

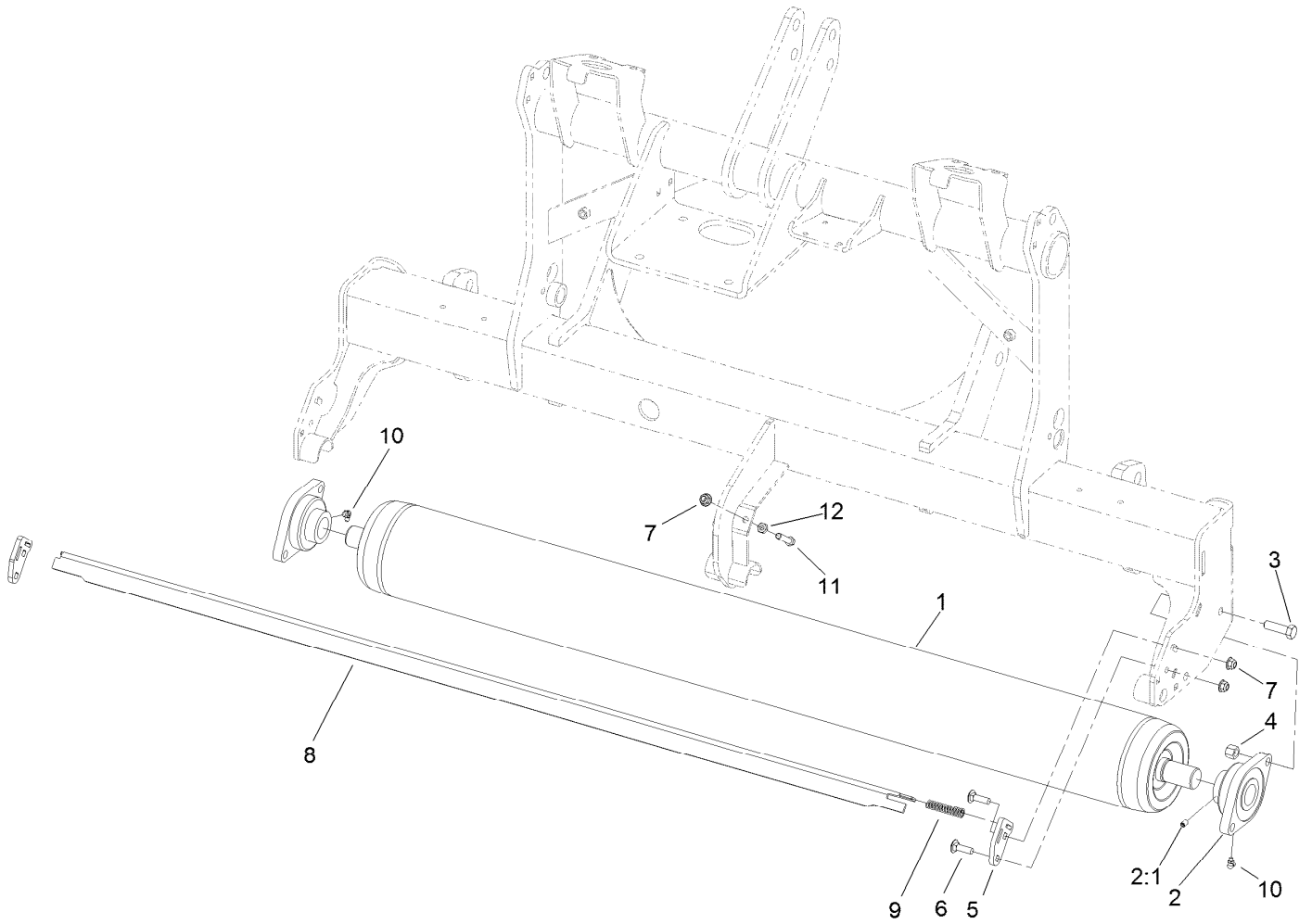

Roller and Scraper Assembly

<i>Ref.</i>	<i>Part Number</i>	<i>Qty.</i>	<i>Description</i>
1	110-4252-03	1	Roller
2	105-0962	2	Bearing-Mount, Flange
2:1	3246-17	1	Setscrew-HSH
3	325-7	4	Screw-HH
4	3296-23	4	Nut-Lock, NI
5	110-4290	2	Arm-Scraper
6	3231-25	4	Bolt-CARR
7	104-8301	5	Nut-HF, NI
8	110-4288-03	1	Scraper-Roller
9	108-4469	1	Spring-Compression
10	302-40	2	Fitting-Grease, 90 DEG
11	323-53	1	Screw-HH
12	3217-7	1	Nut-Hex

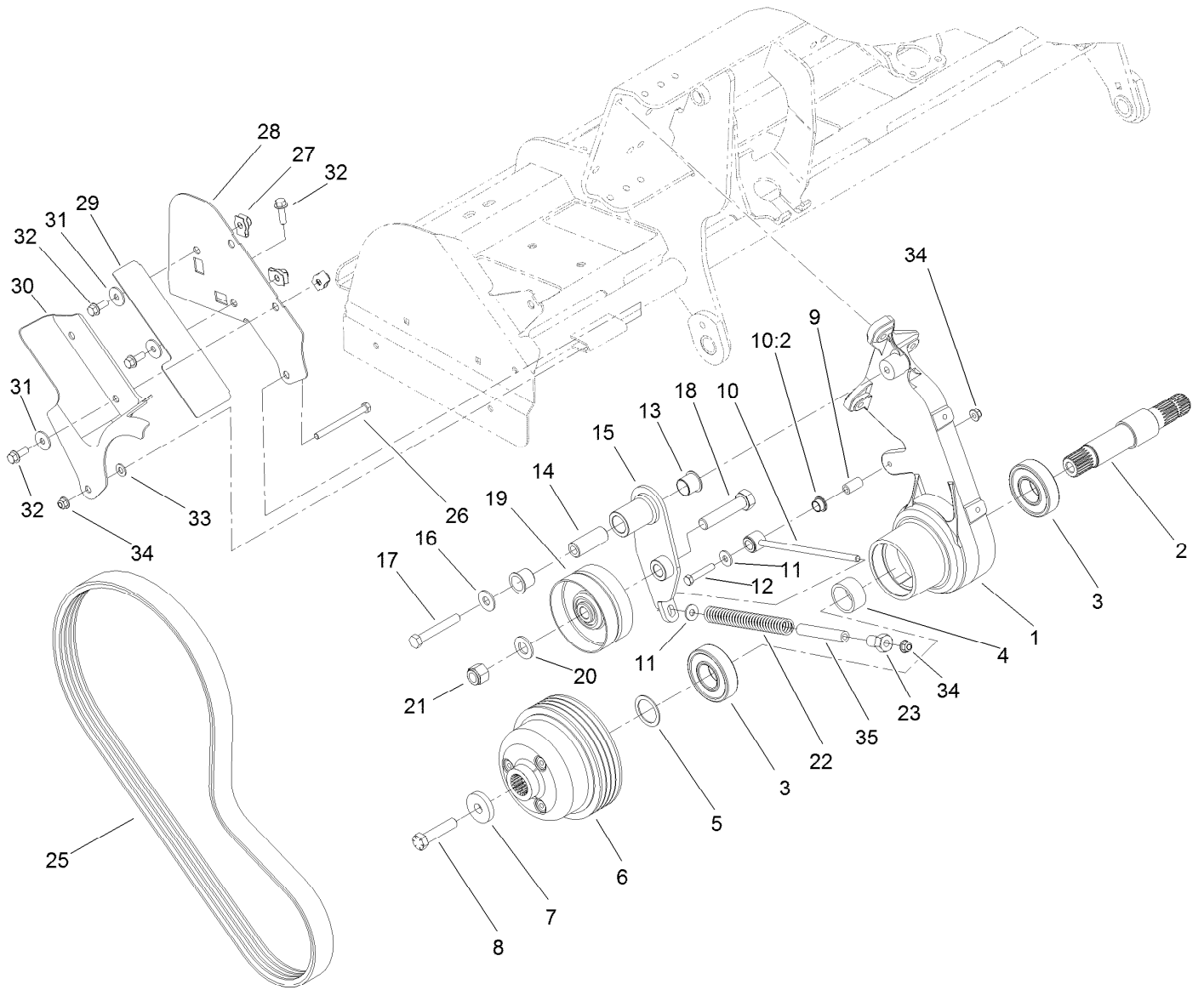

Right Hand Belt Drive Assembly

Ref.	Part Number	Qty.	Description	Ref.	Part Number	Qty.	Description
1	110-4445	1	Support-Pulley, RH	18	328-5	1	Screw-HH
2	110-4527	1	Shaft-Pulley, Splined	19	100-7631	1	Pulley-Idler
3	106-8871	2	Bearing-Ball	20	3256-28	1	Washer-Flat
4	110-4460	1	Spacer-Bearing	21	3296-51	1	Nut-Lock, NI
5	110-4498	1	Washer-Shim	22	110-4632	1	Spring-Compression
6	110-4419	1	Pulley	23	110-4676	1	Nut-Idler
7	105-1016	1	Washer-Hardened	25	110-4327	1	Belt-Banded, 4 Groove
8	110-4614	1	Screw-HH	26	323-17	1	Screw-HH
9	110-4631	1	Tube-Spacer	27	105-4886	4	Nut-Tinnerman
10	115-2815	1	Idler Arm ASM	28	110-4476-03	1	Support-Guard, Belt
10:2	80-1290	2	Bushing	29	114-1463-03	1	Shield-Dirt, RH
11	80-6990	2	Washer-Hardened	30	110-4474	1	Guard-Belt, RH
12	323-11	1	Screw-HH	31	93-8806	4	Washer-Hardened
13	126-1963	2	Bushing-Pivot	32	3234-24	6	Screw-HHF
14	105-0945	1	Sleeve-Pivot	33	3256-24	1	Washer-Flat
15	110-4624-03	1	Arm-Idler, RH	34	104-8301	3	Nut-HF, NI
16	3256-6	1	Washer-Flat	35	115-2800	1	Hose
17	325-14	1	Screw-HH				

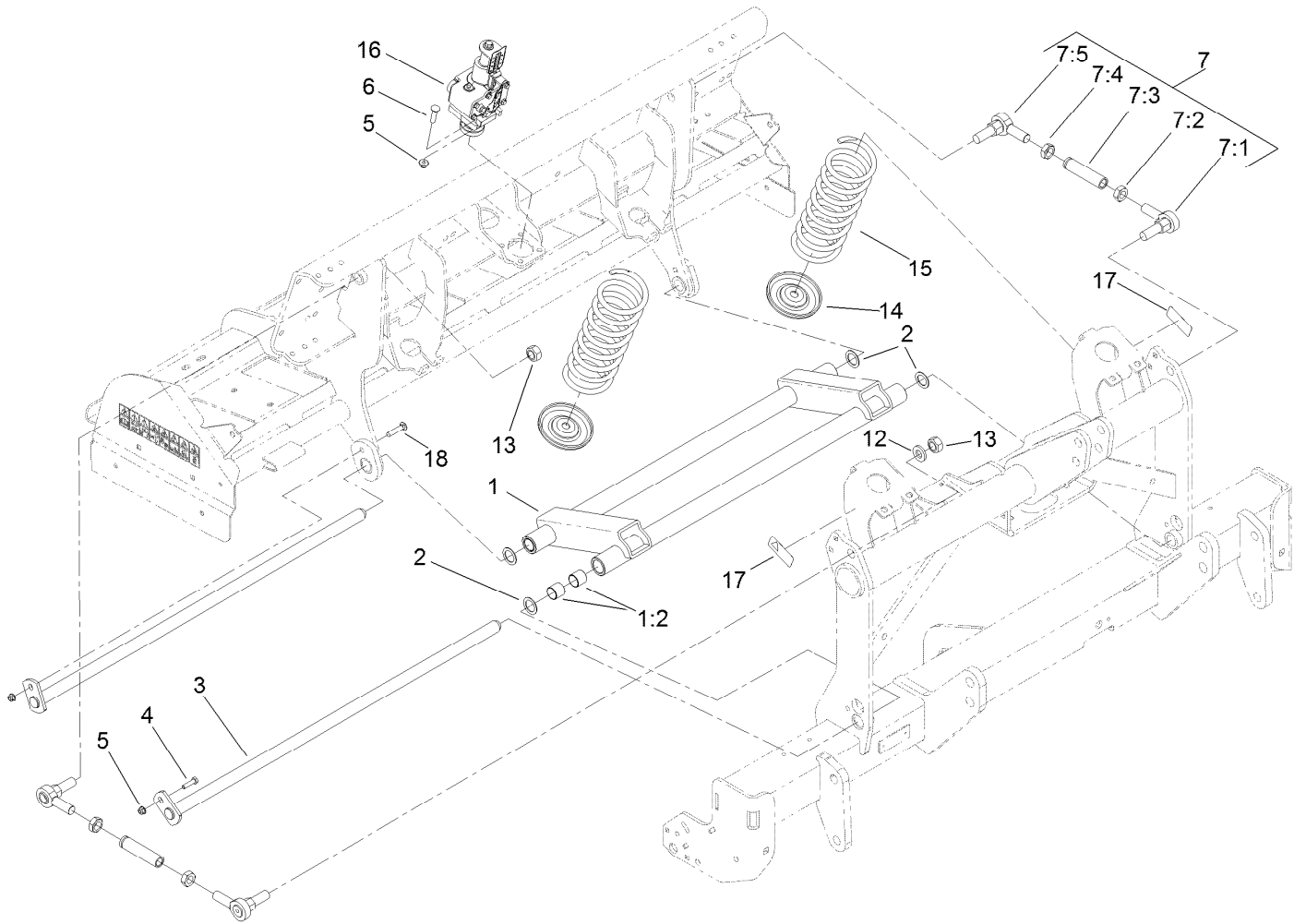

H-Frame Assembly

Ref.	Part Number	Qty.	Description	Ref.	Part Number	Qty.	Description
1	110-4617	1	H-Frame ASM	7:3	110-4251	1	Link-Upper
1:2	110-4612	8	Bushing-Straight	7:4	3220-7	1	Nut-Jam
2	10-8110	4	Washer-Thrust	7:5	2411-40	1	End-Rod
3	110-4249	2	Shaft	12	92-5836	2	Washer
4	323-7	1	Screw-HH	13	3296-50	4	Nut-Lock, NI
5	104-8301	6	Nut-HF, NI	14	110-4287-03	4	Cup-Spring
6	3231-4	4	Screw-CARR	15	140-2566	2	Spring-Compression
7	115-2821	2	Link ASM	16	115-2844	1	Depth Control ASM
7:1	105-1025	1	End-Rod	17	93-6696	2	Decal-Warning
7:2	3220-17	1	Nut-Jam, LH	18	3231-5	1	Screw-CARR

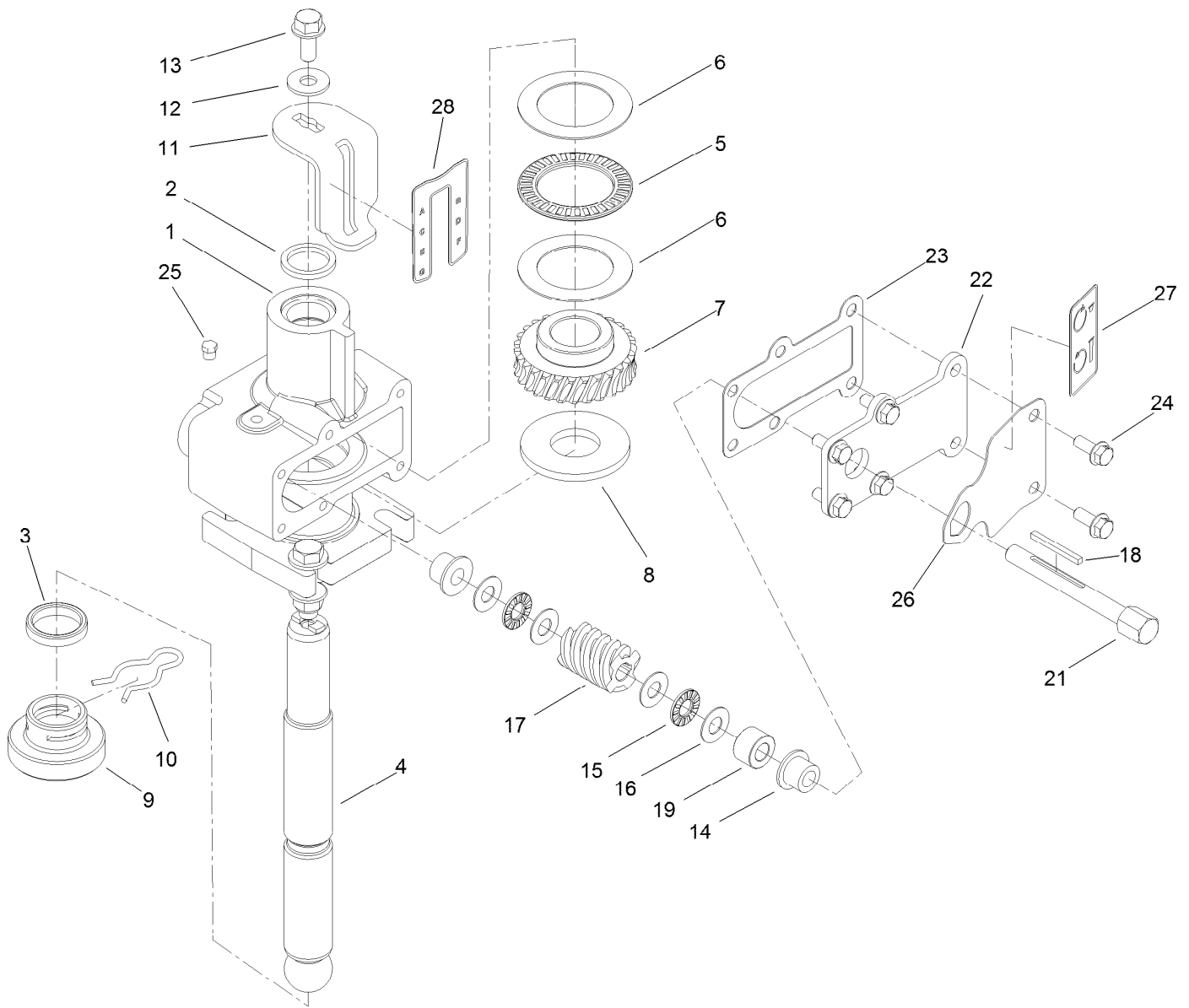

Depth Control Assembly No. 115-2844

Ref.	Part Number	Qty.	Description	Ref.	Part Number	Qty.	Description
1	110-4531	1	Hub-Control, Depth	15	110-4599	2	Bearing-Thrust
2	253-59	1	Seal-Oil	16	73-0041	4	Washer-Thrust
3	7-0045	1	Seal-Oil	17	110-4581	1	Worm-Control, Depth
4	110-4534	1	Shaft-Control, Depth	18	110-4536	1	Key-Gear, Worm
5	110-4600	1	Bearing-Thrust	19	110-4537	1	Spacer-Gear, Worm
6	110-4602	2	Washer-Bearing	21	110-4580	1	Shaft-Gear, Worm
7	110-4582	1	Gear-Worm, Depth Control	22	110-4532-03	1	Cover-Control, Depth
8	112-4953	1	Washer-Plain	23	110-4578	1	Gasket-Control, Depth
9	110-4438	1	Shoe-Control, Depth	24	3234-33	6	Screw-HHF
10	110-4439	1	Clip-Hairpin	25	302-59	1	Plug-EXT Hex Spl
11	110-4533	1	Gage-Control, Depth	26	110-4604	1	Plate-Lock, Depth
12	3256-71	1	Washer-Flat	27	110-4677	1	Decal-Rotation, Depth
13	3234-5	1	Screw-HHF	28	110-4678	1	Decal-Designation, Depth
14	110-4674	2	Bushing-Flange				

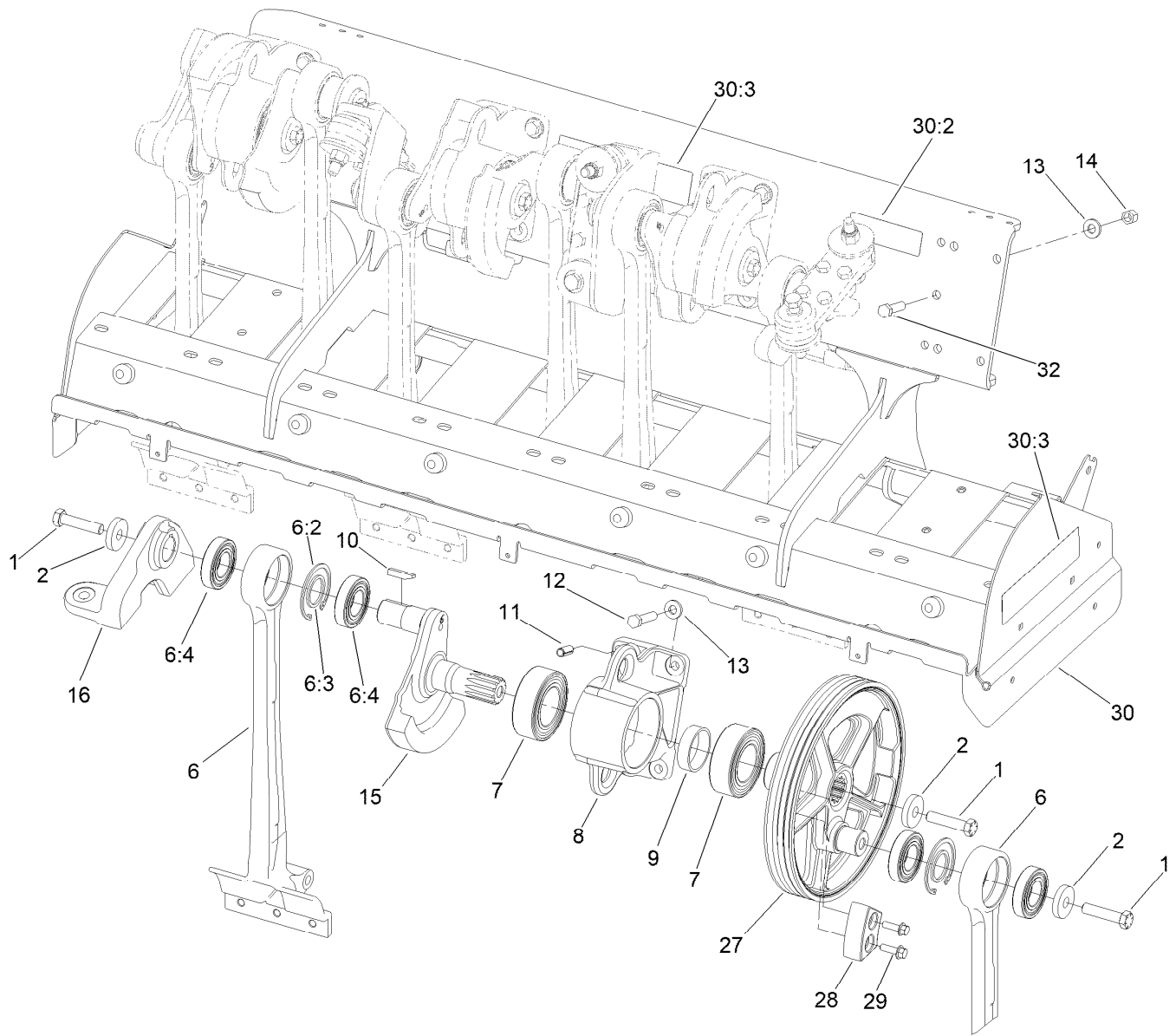

No. 1 and No. 2 Crankarm Assembly

<i>Ref.</i>	<i>Part Number</i>	<i>Qty.</i>	<i>Description</i>	<i>Ref.</i>	<i>Part Number</i>	<i>Qty.</i>	<i>Description</i>
1	110-4614	3	Screw-HH	13	107-3395	7	Washer-Hardened
2	105-1016	3	Washer-Hardened	14	3296-23	2	Nut-Lock, NI
6	140-8809	2	Stomper Arm ASM	15	110-4571	1	Crankarm-No. 2, 4, 6
6:2	32151-76	1	Ring-Retaining, Internal	16	110-4567	1	Coupling-No. 2
6:3	110-4557	1	Spacer-Bearing	27	114-1458	1	Pulley-Crankshaft
6:4	140-8808	2	Bearing	28	114-1456-03	1	Weight-Counter, Pulley
7	110-4555	2	Bearing-Ball, 2 Row	29	3234-24	2	Screw-HHF
8	110-4566	1	Housing-Bearing	30	110-4684	1	Coring Head Frame ASM
9	110-4584	1	Spacer-Bearing	30:2	140-2269	1	Decal-Service, CE
10	110-4546	1	Key-Square	30:3	110-4670	3	Decal-Warning, CE
11	105-1041	2	Pin-Spring	32	325-8	1	Screw-HH
12	325-9	4	Screw-HH				

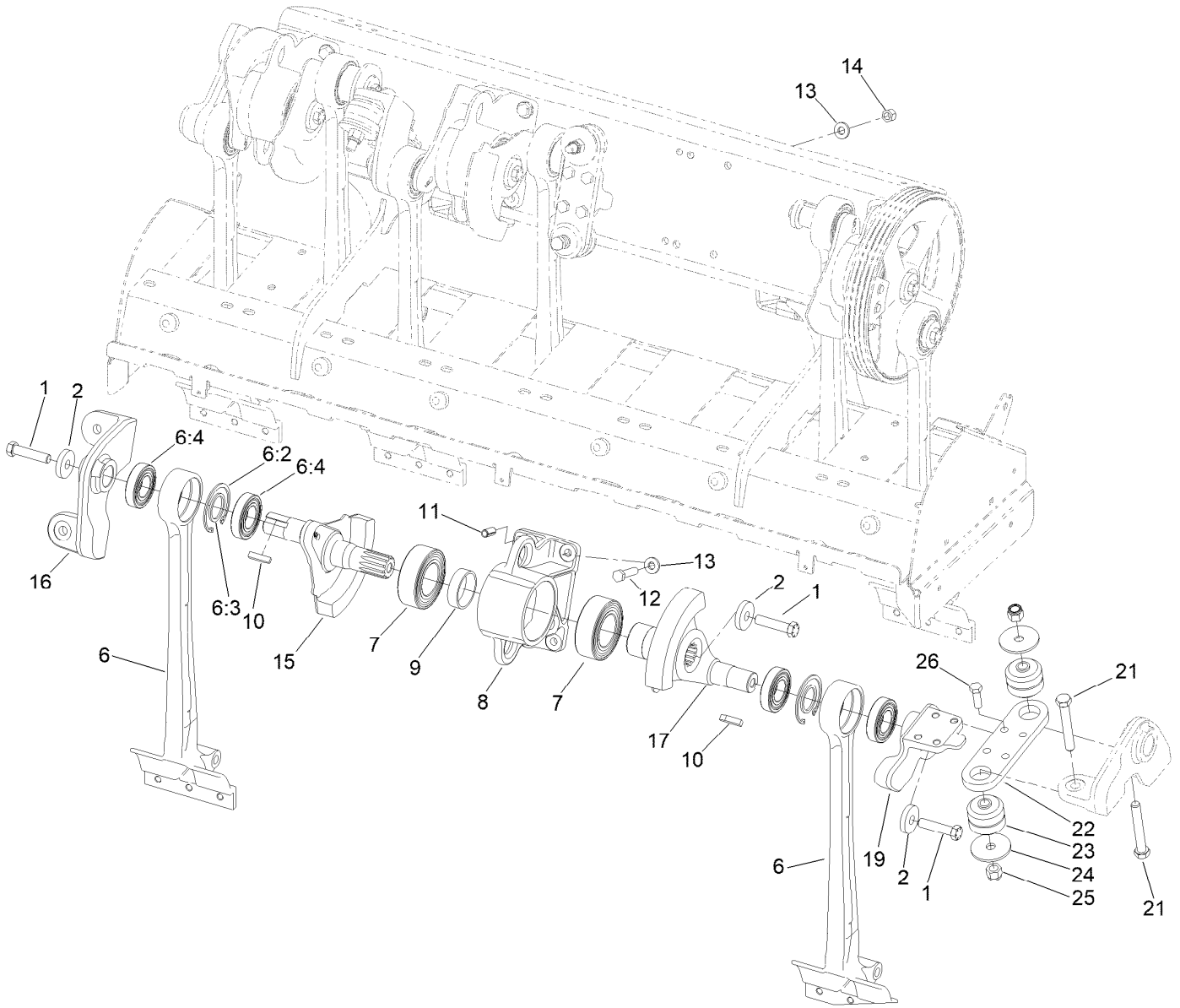

No. 3 and No. 4 Crankarm Assembly

Ref.	Part Number	Qty.	Description
1	110-4614	3	Screw-HH
2	105-1016	3	Washer-Hardened
6	140-8809	2	Stomper Arm ASM
6:2	32151-76	1	Ring-Retaining, Internal
6:3	110-4557	1	Spacer-Bearing
6:4	140-8808	2	Bearing
7	110-4555	2	Bearing-Ball, 2 Row
8	110-4566	1	Housing-Bearing
9	110-4584	1	Spacer-Bearing
10	110-4546	2	Key-Square
11	105-1041	2	Pin-Spring
12	325-9	4	Screw-HH

Ref.	Part Number	Qty.	Description
13	107-3395	8	Washer-Hardened
14	3296-23	4	Nut-Lock, NI
15	110-4571	1	Crankarm-No. 2, 4, 6
16	110-4567	1	Coupling-No. 2
17	110-4572	1	Crankarm-No. 3, 5, 7
19	110-4568	1	Coupling-No. 3
21	327-29	2	Screw-HH
22	105-0974-03	1	Plate-Coupling
23	105-0963	2	Mount-ISO, Crank
24	110-4549	2	Washer-Snubbing
25	3296-53	2	Nut-Lock, NI
26	325-6	4	Screw-HH

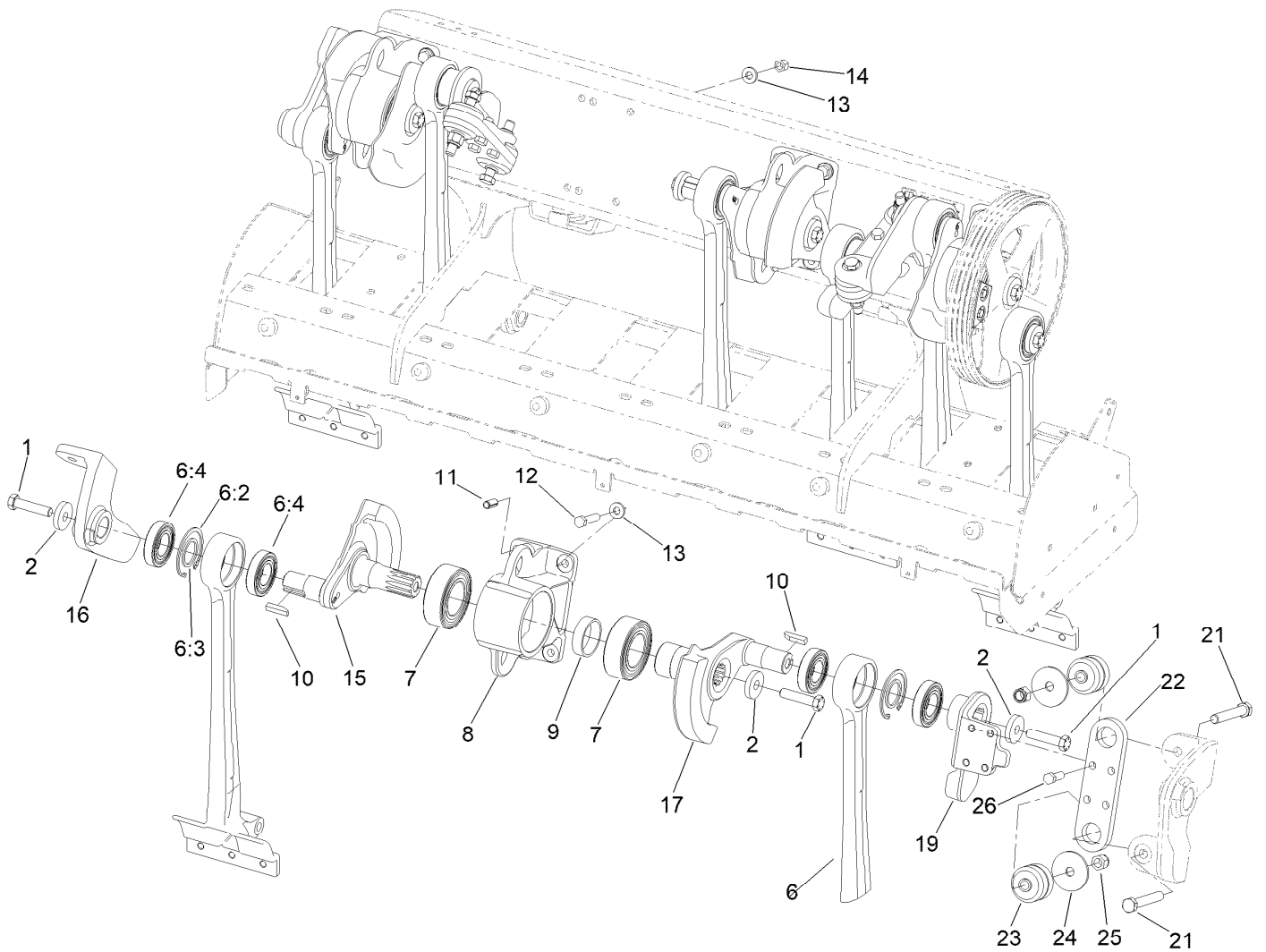

No. 5 and No. 6 Crankarm Assembly

Ref.	Part Number	Qty.	Description
1	110-4614	3	Screw-HH
2	105-1016	3	Washer-Hardened
6	140-8809	2	Stomper Arm ASM
6:2	32151-76	1	Ring-Retaining, Internal
6:3	110-4557	1	Spacer-Bearing
6:4	140-8808	2	Bearing
7	110-4555	2	Bearing-Ball, 2 Row
8	110-4566	1	Housing-Bearing
9	110-4584	1	Spacer-Bearing
10	110-4546	2	Key-Square
11	105-1041	2	Pin-Spring
12	325-9	4	Screw-HH

Ref.	Part Number	Qty.	Description
13	107-3395	8	Washer-Hardened
14	3296-23	4	Nut-Lock, NI
15	110-4571	1	Crankarm-No. 2, 4, 6
16	110-4567	1	Coupling-No. 2
17	110-4572	1	Crankarm-No. 3, 5, 7
19	110-4568	1	Coupling-No. 3
21	327-29	2	Screw-HH
22	105-0974-03	1	Plate-Coupling
23	105-0963	2	Mount-ISO, Crank
24	110-4549	2	Washer-Snubbing
25	3296-53	2	Nut-Lock, NI
26	325-6	4	Screw-HH

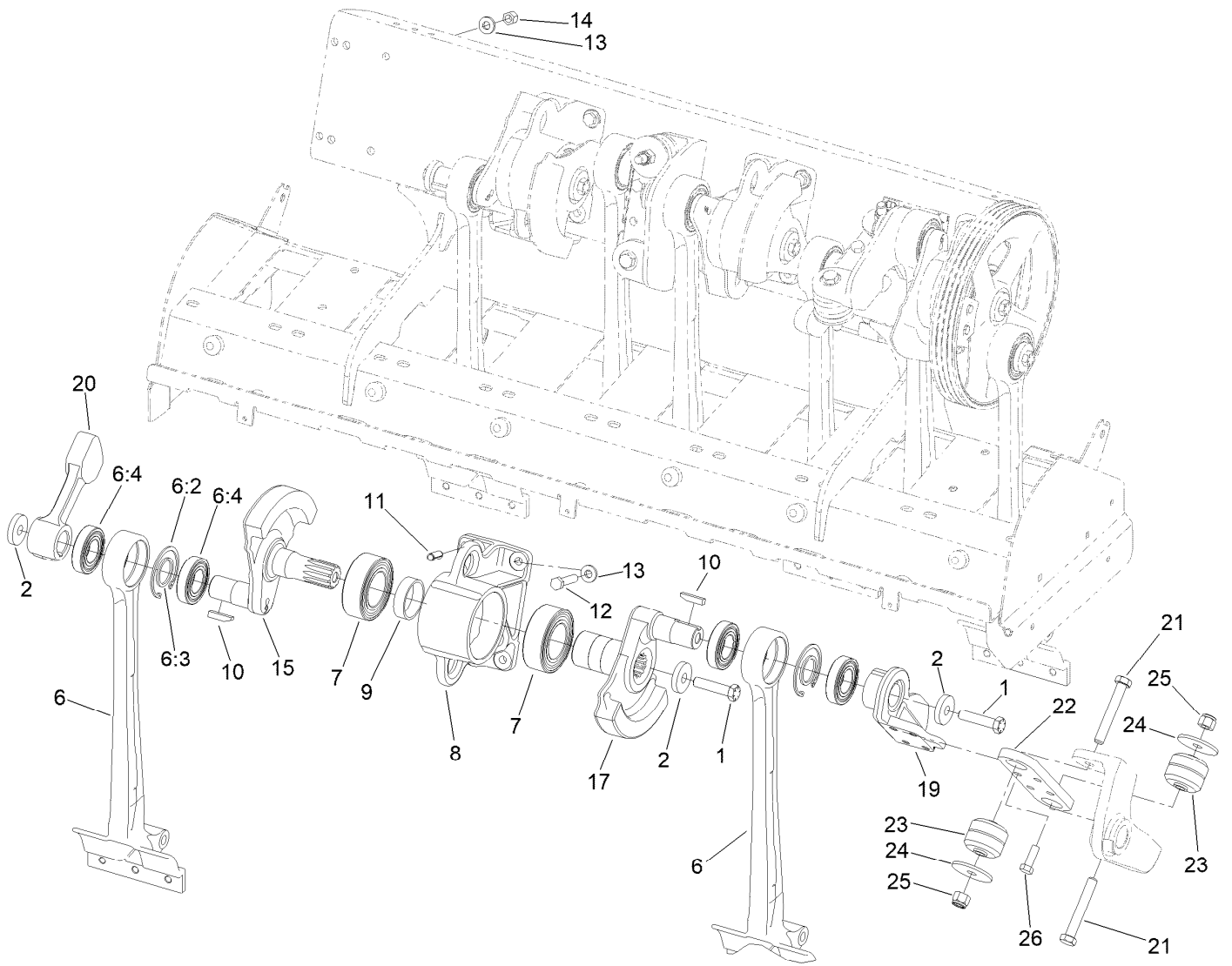

No. 7 and No. 8 Crankarm Assembly

Ref.	Part Number	Qty.	Description	Ref.	Part Number	Qty.	Description
1	110-4614	3	Screw-HH	13	107-3395	8	Washer-Hardened
2	105-1016	3	Washer-Hardened	14	3296-23	4	Nut-Lock, NI
6	140-8809	2	Stomper Arm ASM	15	110-4571	1	Crankarm-No. 2, 4, 6
6:2	32151-76	1	Ring-Retaining, Internal	17	110-4572	1	Crankarm-No. 3, 5, 7
6:3	110-4557	1	Spacer-Bearing	19	110-4568	1	Coupling-No. 3
6:4	140-8808	2	Bearing	20	114-1460	1	Weight-Counter, No. 8
7	110-4555	2	Bearing-Ball, 2 Row	21	327-29	2	Screw-HH
8	110-4566	1	Housing-Bearing	22	105-0974-03	1	Plate-Coupling
9	110-4584	1	Spacer-Bearing	23	105-0963	2	Mount-ISO, Crank
10	110-4546	2	Key-Square	24	110-4549	2	Washer-Snubbing
11	105-1041	2	Pin-Spring	25	3296-53	2	Nut-Lock, NI
12	325-9	4	Screw-HH	26	325-6	4	Screw-HH

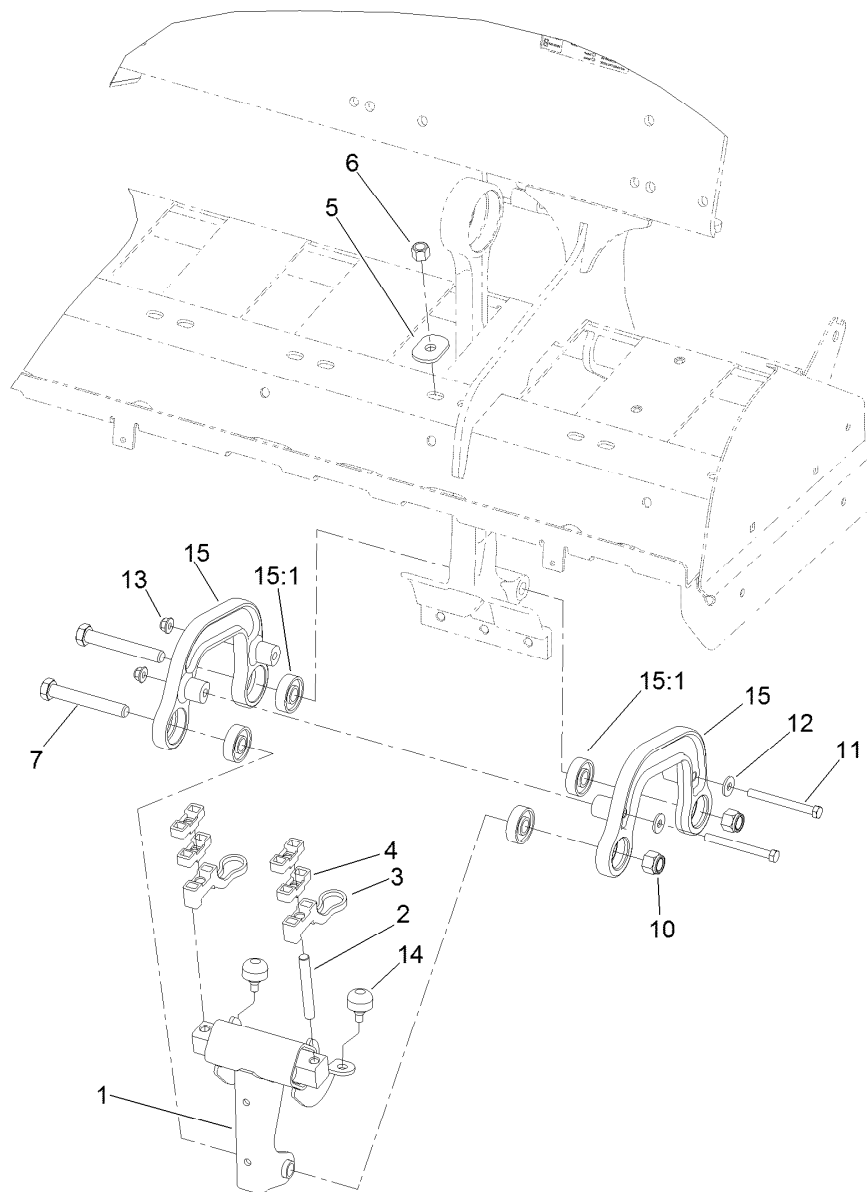

Roto-Link Damper Assembly

Ref.	Part Number	Qty.	Description
1	106-8922	8	Damper
2	110-4504	16	Stud
3	110-4506	16	Bumper-Rotolink
4	110-4507	32	Standoff-Rotolink
5	107-7543	16	Washer-Hardened
6	32128-23	16	Nut-HF
7	327-29	16	Screw-HH
10	3296-53	16	Nut-Lock, NI
11	323-42	16	Screw-HH
12	80-6990	16	Washer-Hardened
13	104-8301	16	Nut-HF, NI
14	87-2440	16	Bumper-Rubber
15	140-6194	16	Link ASM-Damper
15:1	251-311	2	Bearing-Ball

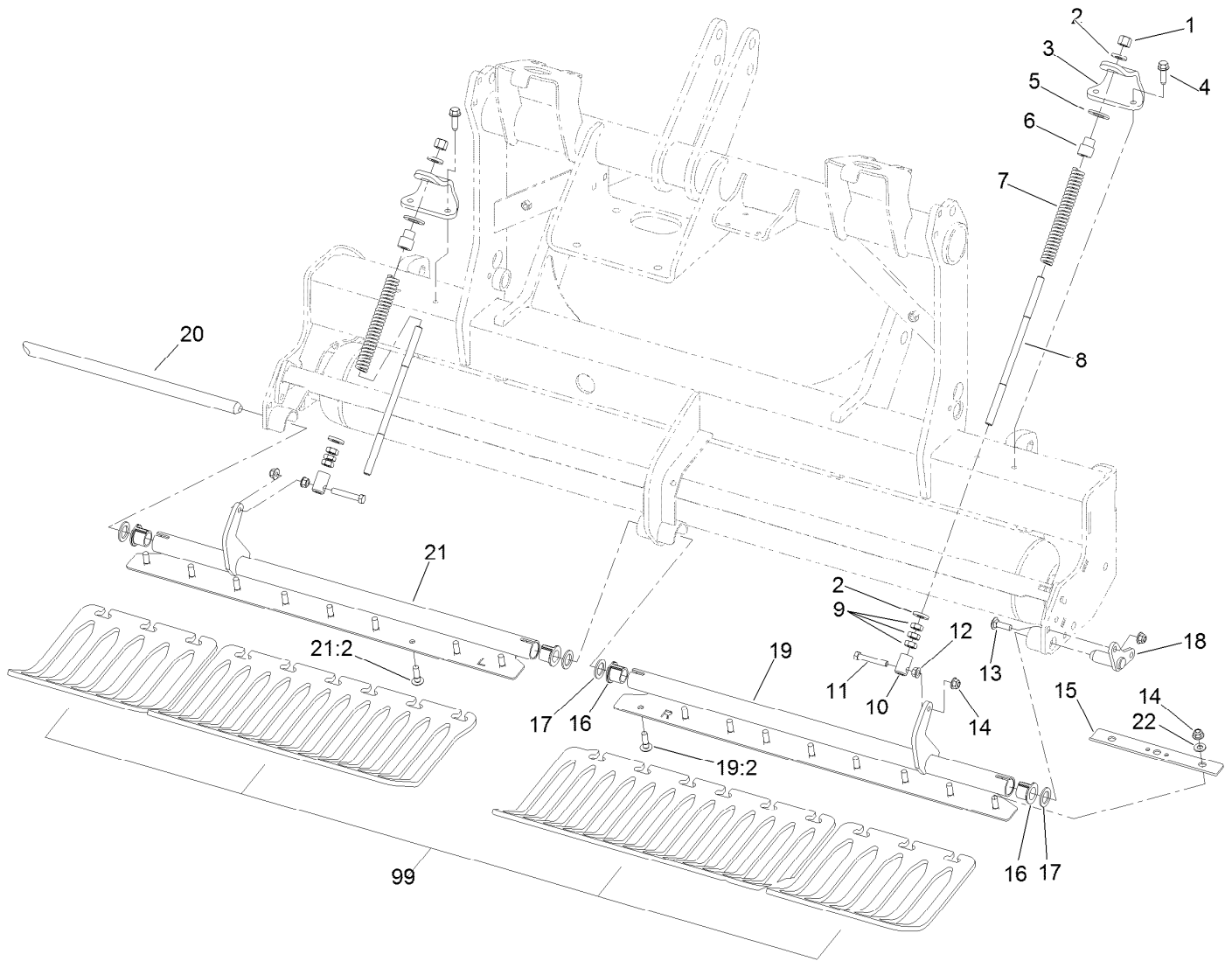

Turf Guard Assembly

Ref.	Part Number	Qty.	Description	Ref.	Part Number	Qty.	Description
1	3296-23	2	Nut-Lock, NI	19	140-6462	1	Bracket ASM-Turf Guard, RH
2	107-3395	4	Washer-Hardened	19:2	125-3318	9	Screw-Neck, Rib
3	110-4267-03	2	Bracket-Spring	20	110-4297	1	Shaft
4	32144-109	4	Screw-Thd	21	140-6463	1	Bracket ASM-Turf Guard, LH
5	3256-28	2	Washer-Flat	21:2	125-3318	9	Screw-Neck, Rib
6	110-4416	2	Sleeve-Rod, Spring	22	3256-24	18	Washer-Flat
7	110-4417	2	Spring-Compression	99	120-1044	2	Guard-Turf, 3-Tine (Short) ●■
8	110-4421	2	Rod-Spring	99	120-1045	2	Guard-Turf, 4-Tine (Short) ●■
9	3218-5	6	Nut-Jam	99	120-1057	1	Guard-Turf, 3-Tine (RH) ■
10	99-8662	2	Tube-Spring	99	120-1058	1	Guard-Turf, 3-Tine (LH) ■
11	323-45	2	Screw-HH	99	120-1059	1	Guard-Turf, 4-Tine (RH) ●■
12	32128-40	4	Nut-Flange	99	120-1060	1	Guard-Turf, 4-Tine (LH) ●■
13	3231-25	4	Bolt-CARR	99	120-1061	1	Guard-Turf, 5 Tine (RH) ●■
14	104-8301	22	Nut-HF, NI	99	120-1062	1	Guard-Turf, 5 Tine (LH) ●■
15	110-4274-03	6	Clamp-Guard, Turf				
16	107-7581	4	Bushing-Flange, Keyed				
17	3-7898	4	Washer-Thrust				
18	110-4296	1	Shaft-Stub				

● Not illustrated

■ Optional Equipment

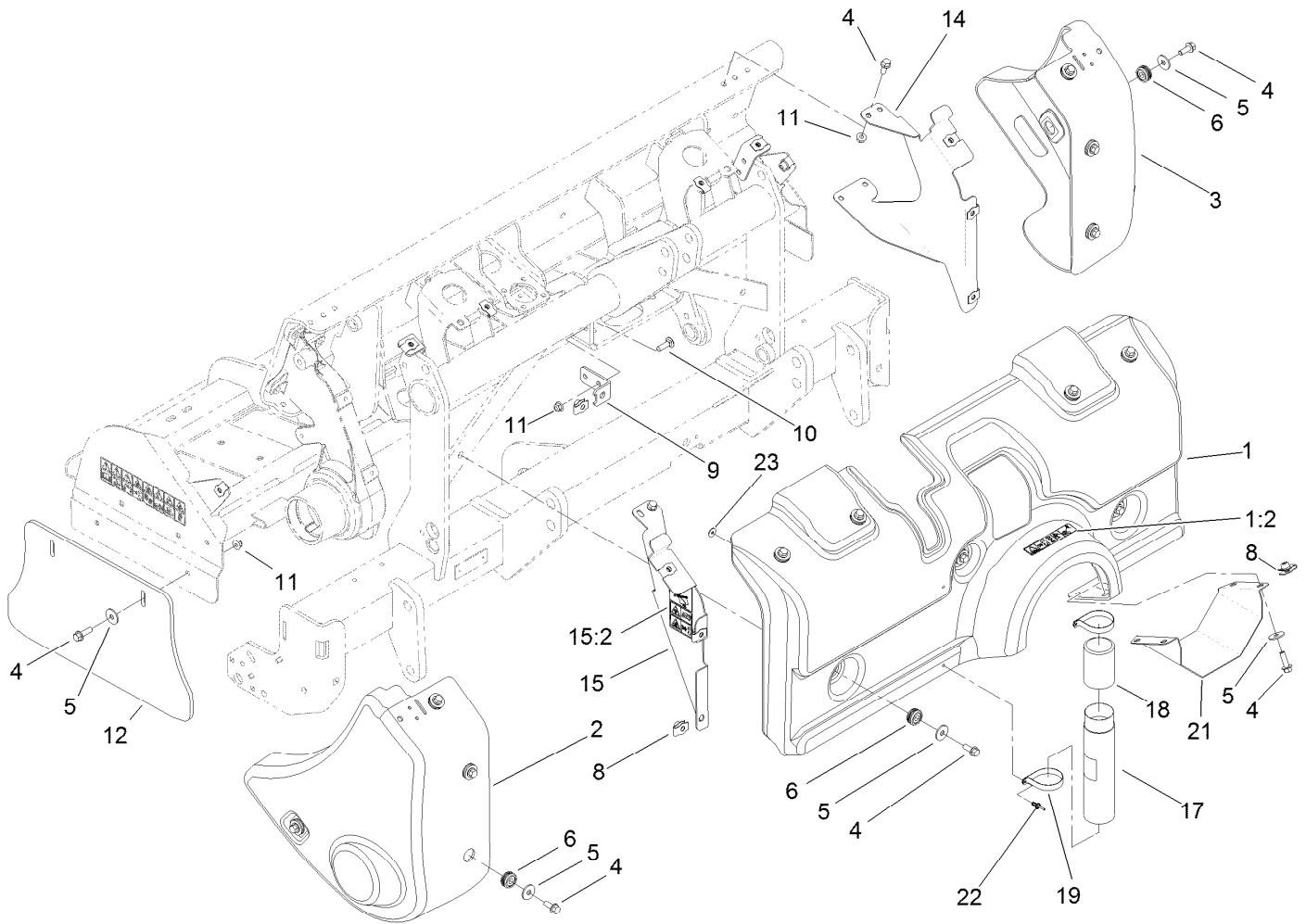

Front Cover Assembly

<i>Ref.</i>	<i>Part Number</i>	<i>Qty.</i>	<i>Description</i>	<i>Ref.</i>	<i>Part Number</i>	<i>Qty.</i>	<i>Description</i>
1	110-4682	1	Front Cover ASM	12	105-1069	2	Shield-Side
1:2	110-4668	1	Decal-Warning, PTO	14	110-4503-03	1	Support-Shield, LH
2	110-4466	1	Shield-Pulley, RH	15	110-4680	1	RH Shield Support ASM
3	110-4467	1	Shield-Pulley, LH	15:2	110-4667	1	Decal-Warning, Spring
4	3234-24	31	Screw-HHF	17	104-7050	1	Tube-Manual
5	93-8806	23	Washer-Hardened	18	104-7048	1	Cap-Housing
6	110-4697	15	Mount-Isolated	19	2412-120	2	Clamp-R
8	105-4886	17	Nut-Tinnerman	21	110-4422-03	1	Shield-PTO
9	110-4478	3	Support-Cover, Front	22	114439	2	Rivet-Blind
10	3231-25	6	Bolt-CARR	23	3256-61	2	Washer-Flat
11	104-8301	16	Nut-HF, NI				

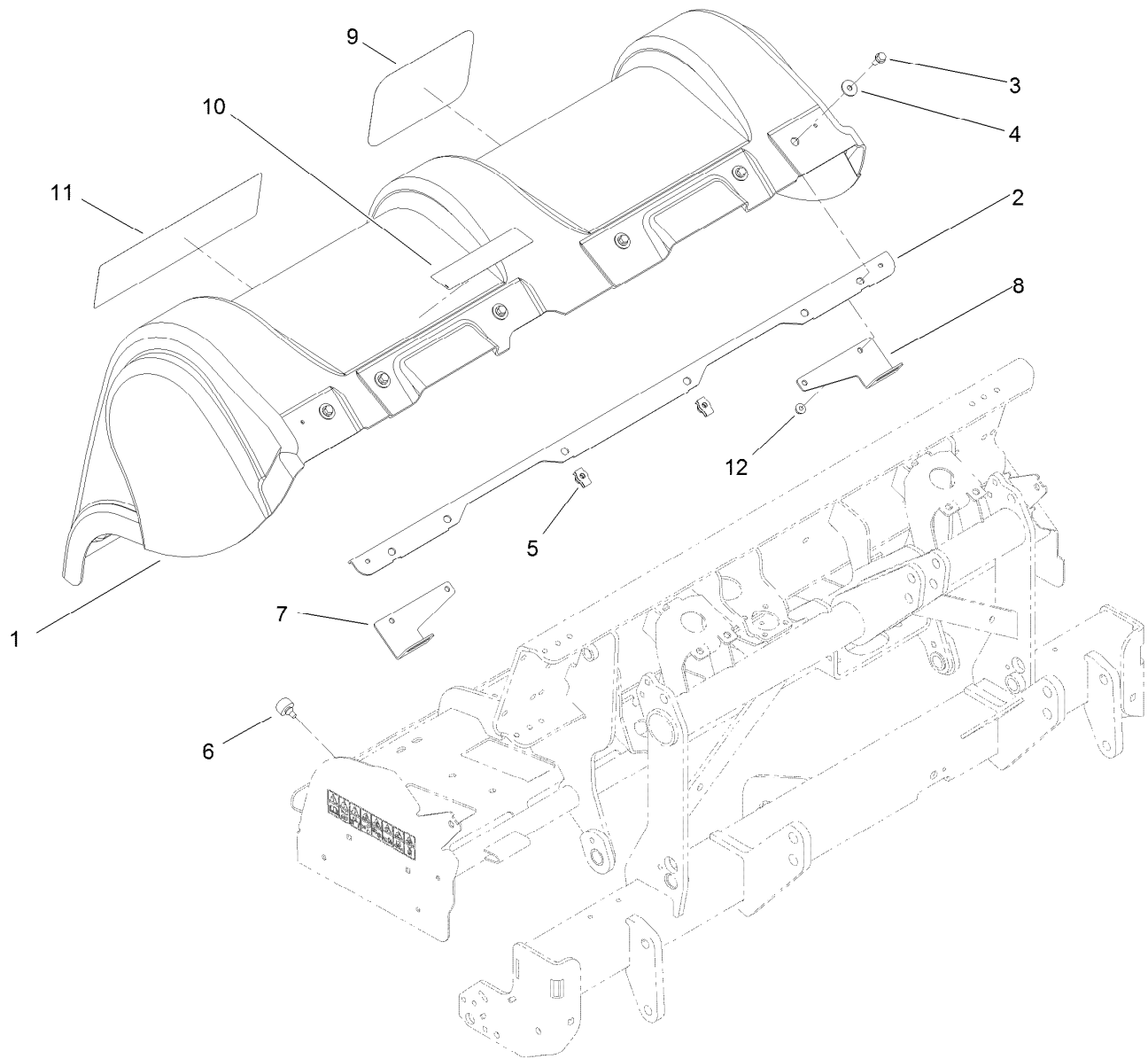

Rear Cover Assembly

<i>Ref.</i>	<i>Part Number</i>	<i>Qty.</i>	<i>Description</i>
1	110-4465	1	Hood-Rear
2	110-4482-03	1	Stiffener-Hood
3	3234-24	6	Screw-HHF
4	93-8806	6	Washer-Hardened
5	105-4886	2	Nut-Tinnerman
6	87-2440	6	Bumper-Rubber
7	110-4550-03	1	Stirrup-Hood, RH
8	110-4551-03	1	Stirrup-Hood, LH
9	67-7310	1	Decal
10	106-8856	1	Decal - Tine Depth, CE
11	110-4426	1	Decal-Procure
12	104-8301	4	Nut-HF, NI

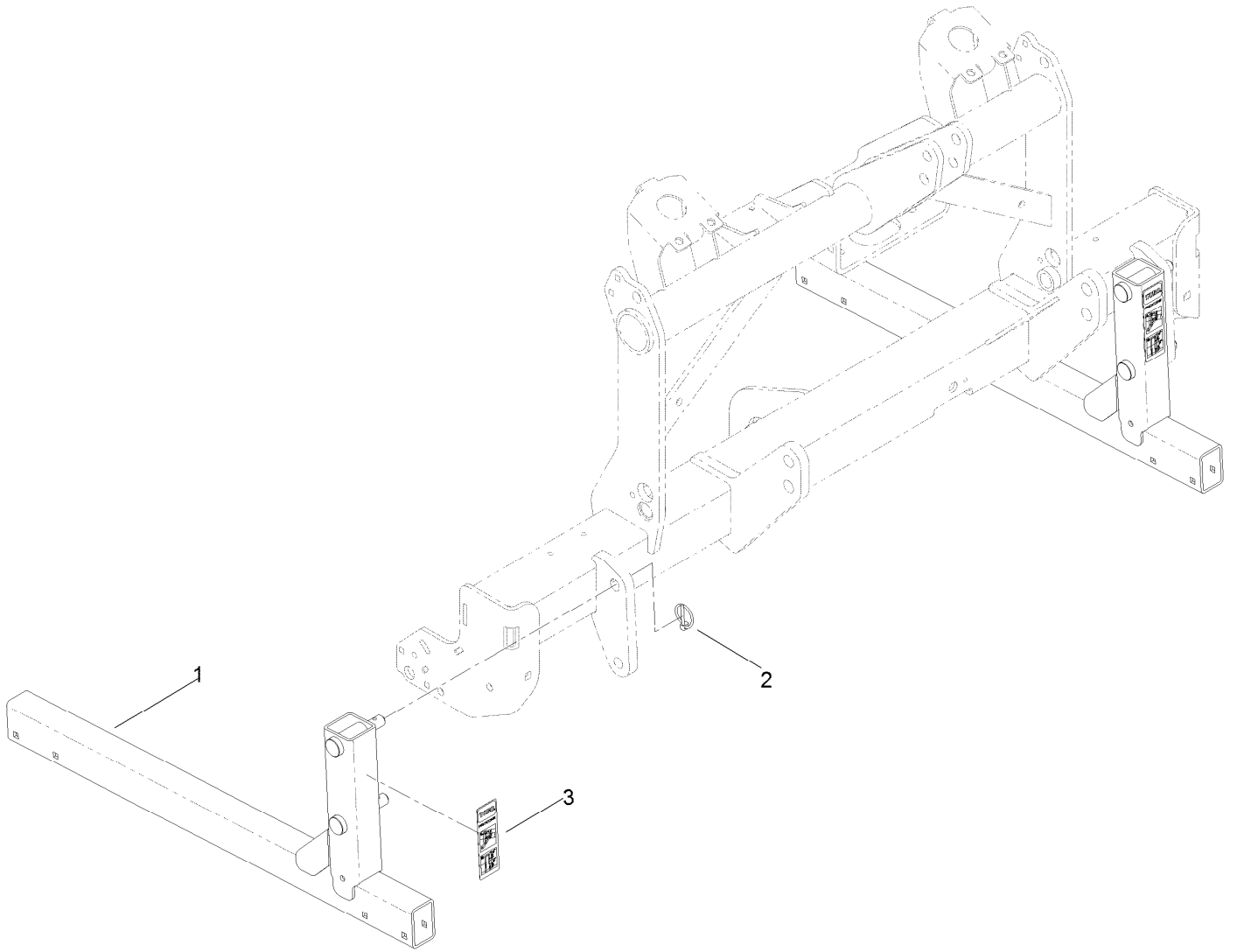

Storage Stand Assembly

<i>Ref.</i>	<i>Part Number</i>	<i>Qty.</i>	<i>Description</i>
1	110-4292-03	2	Stand
2	92-1298	4	Pin-Lynch
3	110-4666	2	Decal-Service, Storage

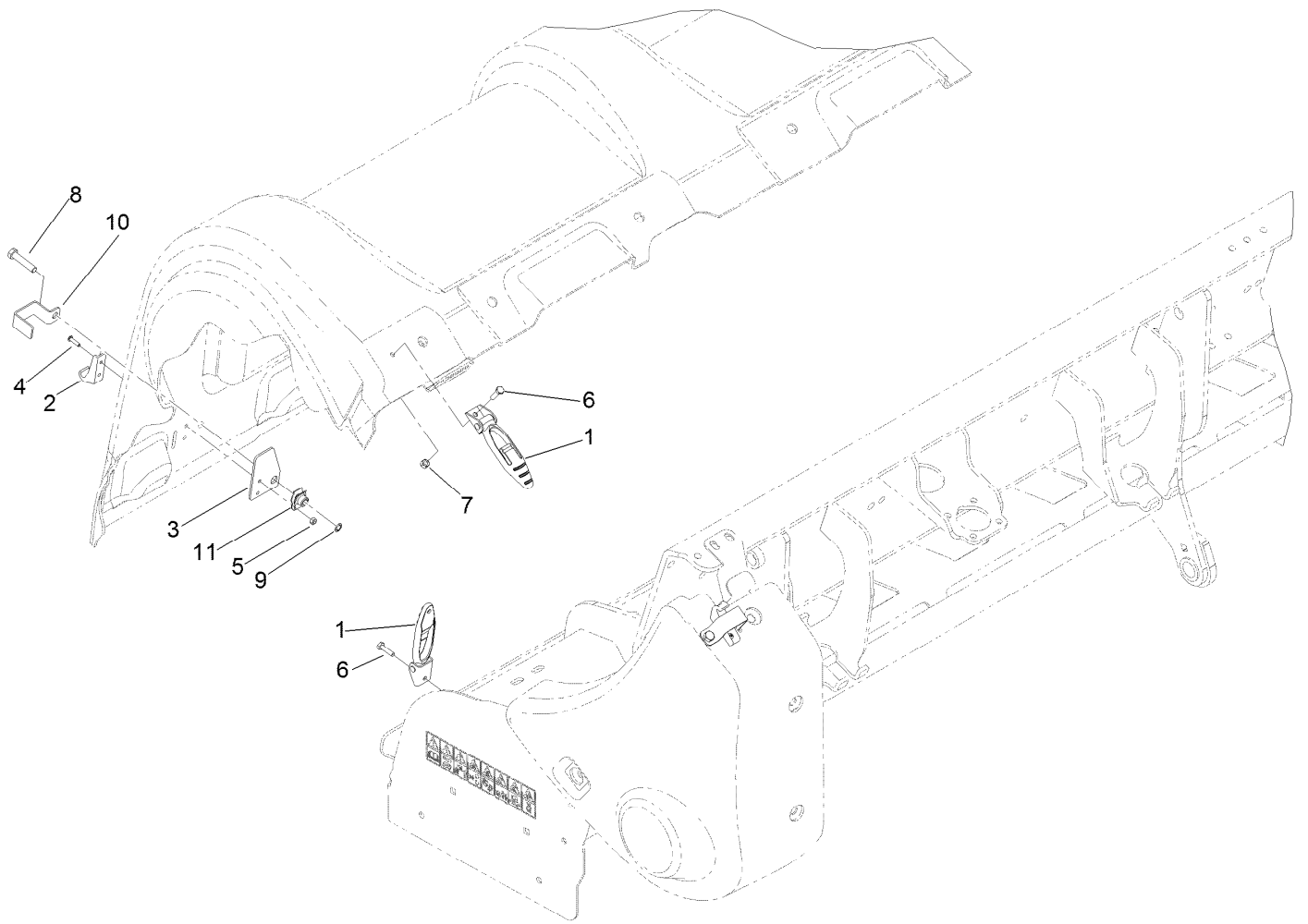

Cover Latch Assembly

<i>Ref.</i>	<i>Part Number</i>	<i>Qty.</i>	<i>Description</i>
1	103-2898	5	Latch-Rubber
2	103-2897	5	Latch-Catch
3	110-4672	5	Plate-Reinforcement
4	104-2408	10	Screw-HSBH
5	3296-2	10	Nut-Lock, NI
6	321-6	5	Screw-HH
7	3296-42	5	Nut-Lock, NI
8	323-53	4	Screw-HH
9	32151-72	4	Ring-Retaining
10	110-4673	4	Lock-Latch, CE
11	105-4886	4	Nut-Tinnerman

Attachments and Accessories

For 09715 ProCore 864 Aerator

Product Name	Model/Part
Windrower Kit	09220
Four-Tine Head Quick Lock	09719
2 x 5 Mini Tine Head	09736
1 x 6 Mini Tine Head	09737
Needle Tine Head	09739
3/4in Three-Tine Head	09794
3/4in Four-Tine Head	09796
7/8in Three-Tine Head	09797
Premium All Season Gear Lube (5 Gallon Pail)	108-1187
Premium All Purpose Grease (Tube)	108-1190
Premium All Season Gear Lube (Quart)	108-1590
Procore Ce Completion Kit	110-4693
Sleeve Tool ASM	114-0590-01
Guarded Driveshaft	115-2839
Turf Guard 3 Tine (Short)	120-1044
Turf Guard 4 Tine (Short)	120-1045
Turf Guard 5 Tine (Short)	120-1047
Turf Guard 6 Tine (Short)	120-1050
Turf Guard 3 Tine (RH)	120-1057
Turf Guard 3 Tine (LH)	120-1058
Turf Guard 4 Tine (RH)	120-1059
Turf Guard 4 Tine (LH)	120-1060
Turf Guard 5 Tine (RH)	120-1061
Turf Guard 5 Tine (LH)	120-1062
Turf Guard 6 Tine (RH)	120-1063
Turf Guard 6 Tine (LH)	120-1064



Count on it.