



Count on it.

Parts Catalog

Ultra Buggy® e2500

Model No. 68037—Serial No. 413000000 and Up



Ordering Replacement Parts

To order replacement parts, please supply the part number, the quantity, and the description of each part desired.

Understanding Reference Numbers

Each identified part in an illustration has a reference number. The reference number for a part also appears in the parts list, along with other information about the part.

This catalog uses two special reference number formats, one to indicate parts in a service assembly and another to indicate the quantity of a given part in an illustration.

Service Assembly Reference Numbers

Parts in service assemblies have reference numbers in the form a:b. The a represents the reference number of the entire service assembly and the b represents a sequential number unique to each part within the service assembly.

For example, a wheel assembly might be identified by reference number 6, the tire by 6:1, the valve by 6:2, and the wheel by 6:3. When you order the assembly identified by reference number 6, you receive all parts identified by reference numbers 6:1, 6:2, and 6:3. However, you may also order any part individually. Reference numbers of this type appear in illustration and in parts lists.

Reference Numbers Indicating Quantity

In an illustration, if a reference number indicates more than one part, the reference number has the form nX y. The n represents the quantity of the part, the X is the multiplication symbol, and the y represents the reference number.

For example, in an illustration, the reference number 2X 37 means that two of the parts identified by reference number 37 are indicated.

Contents

Frame Assembly.....	4
Drivetrain and Wheel Assembly.....	5
Platform Assembly.....	6
Handle Assembly.....	7
Steering Assembly.....	8
Tower and Hood Assembly.....	9
Tub Assembly.....	10
Battery Assembly.....	11
Harness Assembly.....	12
Battery Cable Assembly.....	13
Attachments and Accessories.....	14

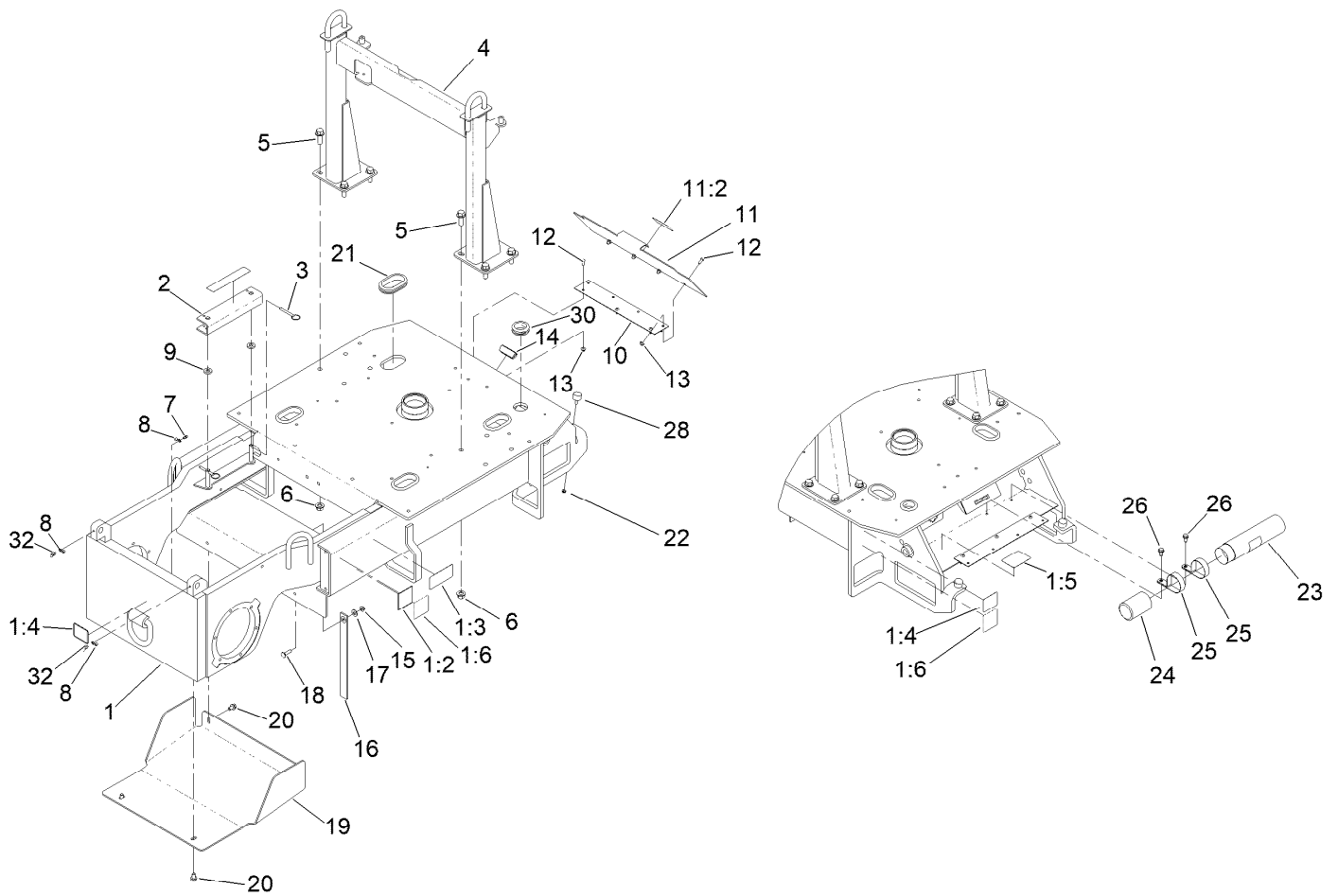

Frame Assembly

Ref.	Part Number	Qty.	Description	Ref.	Part Number	Qty.	Description
1	147-3218	1	Frame ASM	13	104-7201	7	Nut-HF, NI
1:2	125-4967	2	Decal-Lift Here	14	99-3497	1	Magnet
1:3	125-4959	2	Decal-Warning, Crushing	15	104-8300	1	Nut-HF, NI
1:4	125-6694	3	Decal-Tie Down	16	139-7731	1	Strap, Static
1:5	145-1170	1	Decal-Warning, Charger	17	3256-3	1	Washer-Flat
1:6	145-1181	4	Decal-Forklift Pocket	18	3230-3	1	Screw-CARR
2	144-1704	1	Cylinder Locking ASM	19	144-1788-03	1	Plate-Skid
3	108-0094	2	Pin-Cotterless	20	32144-69	4	Screw-HWHTF
4	144-1677-03	1	Frame Lift ASM-Welded	21	145-4923	4	Grommet
5	100-6116	8	Screw-HHF	22	3296-56	2	Nut-Lock, NI
6	99-5107	8	Nut-Lock	23	104-7050	1	Tube-Manual
7	302-5	2	Fitting-Grease	24	104-7048	1	Cap-Housing
8	ST47001	4	Cap-Plug	25	2412-133	2	Clamp-R
9	83-1470	2	Washer-Neoprene	26	32144-70	2	Screw-HWHTF
10	132-9021	1	Hinge-Hood	28	1-523420	2	Bumper
11	147-3224	1	Cover-Cable	30	137-1812	1	Grommet
11:2	145-1174	1	Decal-Battery Charger	32	302-11	2	Fitting-Lube, 45 DEG
12	3274-31	7	Screw-HSBH				

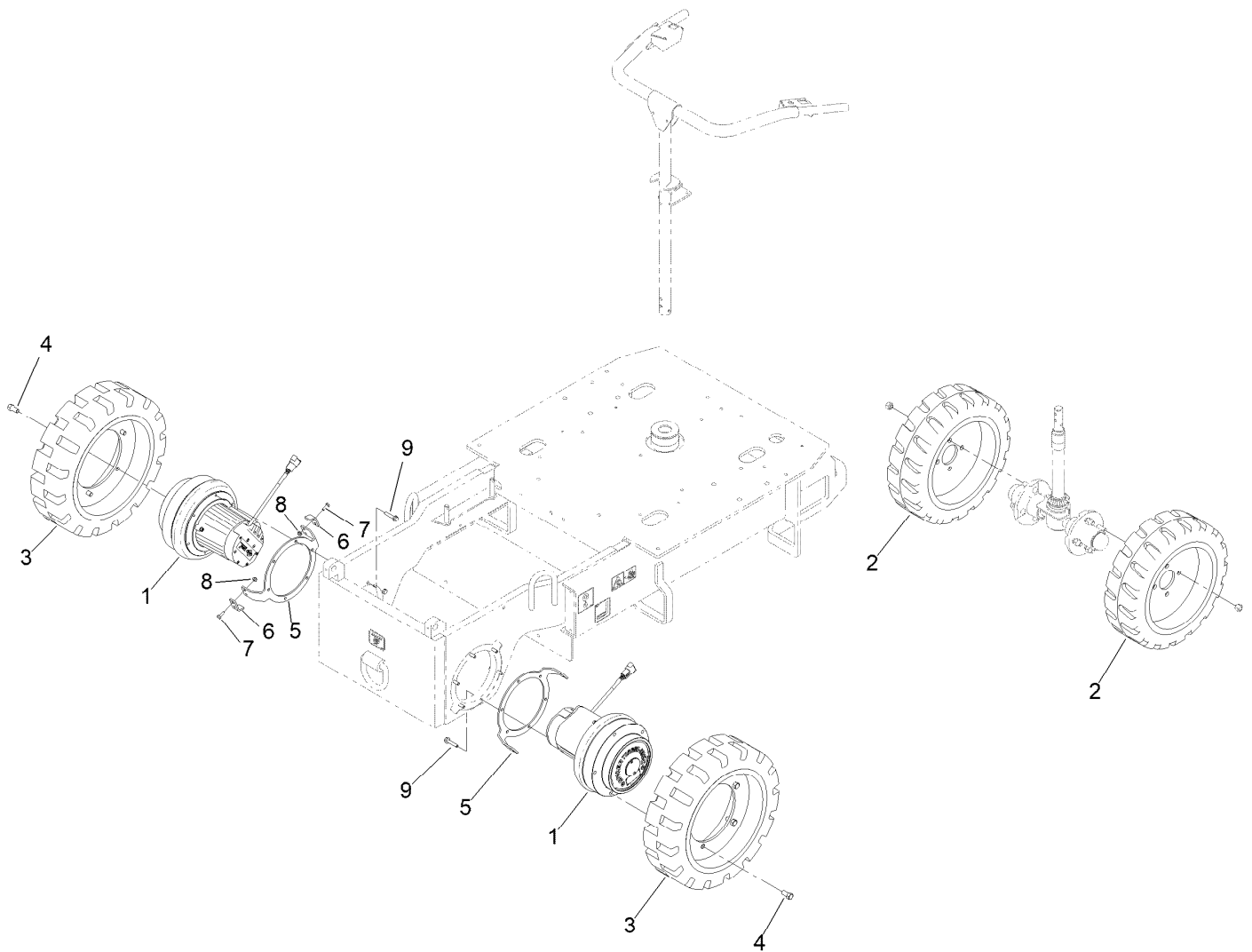

Drivetrain and Wheel Assembly

Ref.	Part Number	Qty.	Description
1	138-8975	2	Motor/Gen Torque-Hub ASM-3Kw 31:1 Rdctn
2	145-4938	2	Tire-Solid
3	145-2376	2	Tire-Solid
4	144-1739	10	Screw-HH, Lug M12 X 1.50
5	145-4984-03	2	Spacer-Wheel
6	145-4990	4	Plate-Wiper
7	321-4	8	Screw-HH
8	104-7201	8	Nut-HF, NI
9	33104-040	12	Screw-HHF

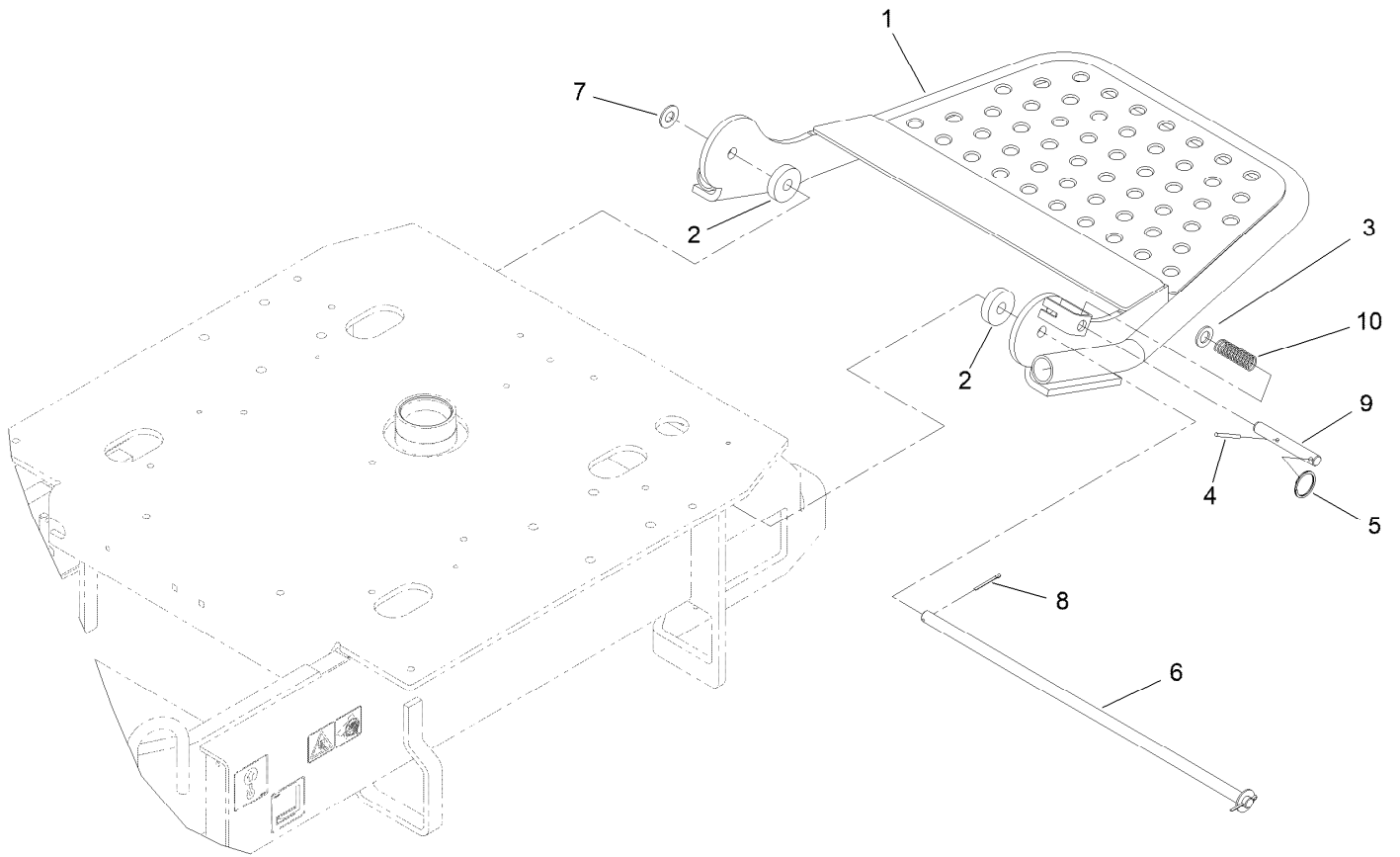

Platform Assembly

<i>Ref.</i>	<i>Part Number</i>	<i>Qty.</i>	<i>Description</i>
1	144-1722-03	1	Step-Platform-Welded
2	144-1725	2	Spacer
3	33098-00	1	Washer-Flat
4	ST81122	1	Pin
5	ST81124	1	Ring-Split
6	ST45113	1	Shaft-Pivot, Step
7	3256-27	2	Washer-Flat
8	3272-13	2	Pin-Cotter
9	144-1721	1	Pin-Lockout, Step
10	ST45055	1	Spring-Compression

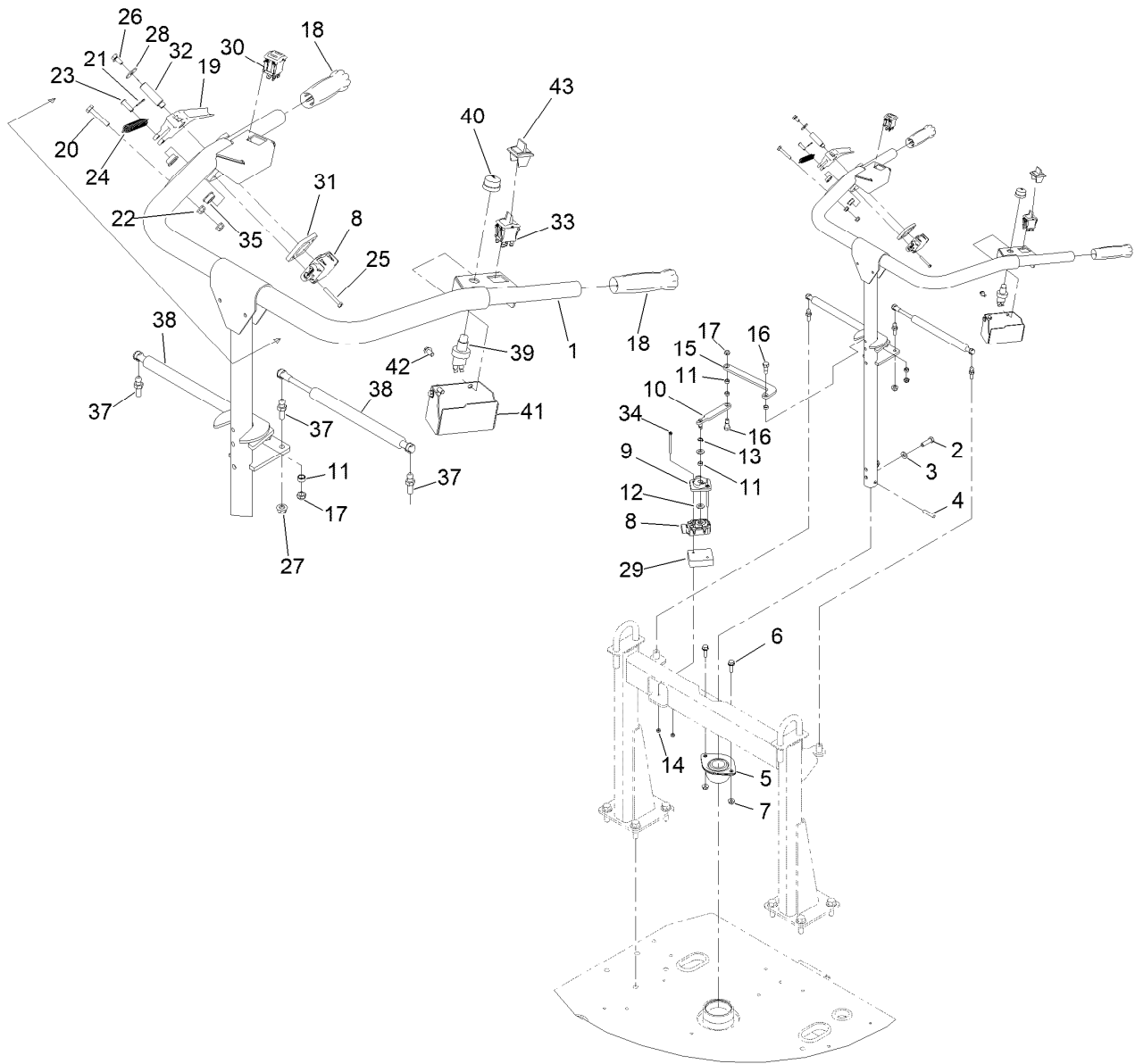

Handle Assembly

Ref.	Part Number	Qty.	Description	Ref.	Part Number	Qty.	Description
1	145-3199-03	1	Handle ASM [black]	22	119-4040	2	Nut-HF, NI
2	323-7	2	Screw-HH	23	1-808265	1	Pin-Clevis
3	100-4852	2	Washer-Hardened	24	137-2591	1	Spring-Extension
4	ST80309	1	Pin	25	32105-1	2	Screw-SHH
5	ST45930	1	Spherical Bearing ASM	26	119-1065	1	Screw-HWH
6	3234-29	2	Screw-HHF	27	104-8300	2	Nut-HF, NI
7	32128-26	2	Nut-HF	28	137-3106	1	Washer-Plain
8	122-0917	2	Sensor-Position	29	144-7124-0P	1	Spacer, Steering-Sensor
9	144-1731	1	Mount-Linkage	30	145-1152	1	Switch-Directional
10	144-1728	1	Linkage ASM	31	144-1729-0P	1	Plate-Mount, Linkage
11	120-9708	5	Bushing	32	145-1153	1	Shaft-Sensor
12	132-4593	2	Washer	33	MSC13973	1	Switch,(On)Off(On),Pinned,CB
13	105-2410	1	Ring-Retaining	34	32105-30	2	Screw-SHH
14	120-9659	2	Nut-Lock, NI	35	145-1154	2	Bushing
15	144-1734	1	Linkage-Steering	37	145-4951	4	Stud-Ball
16	59-5400	2	Bolt-Shoulder	38	145-4921	2	Damper-Gas
17	3296-47	2	Nut-Lock,NI	39	112-3324	1	Switch-Horn
18	T62021010	2	Grip-Vinyl, Black	40	112-3313	1	Nut-Weatherproof
19	144-7153	1	Handle	41	147-3282-03	1	Cover-Switch
20	321-43	1	Capscrew	42	32144-4	3	Screw-HWH
21	3272-1	1	Pin-Cotter	43	MSC13972	1	Boot,K2 Paddle Switch

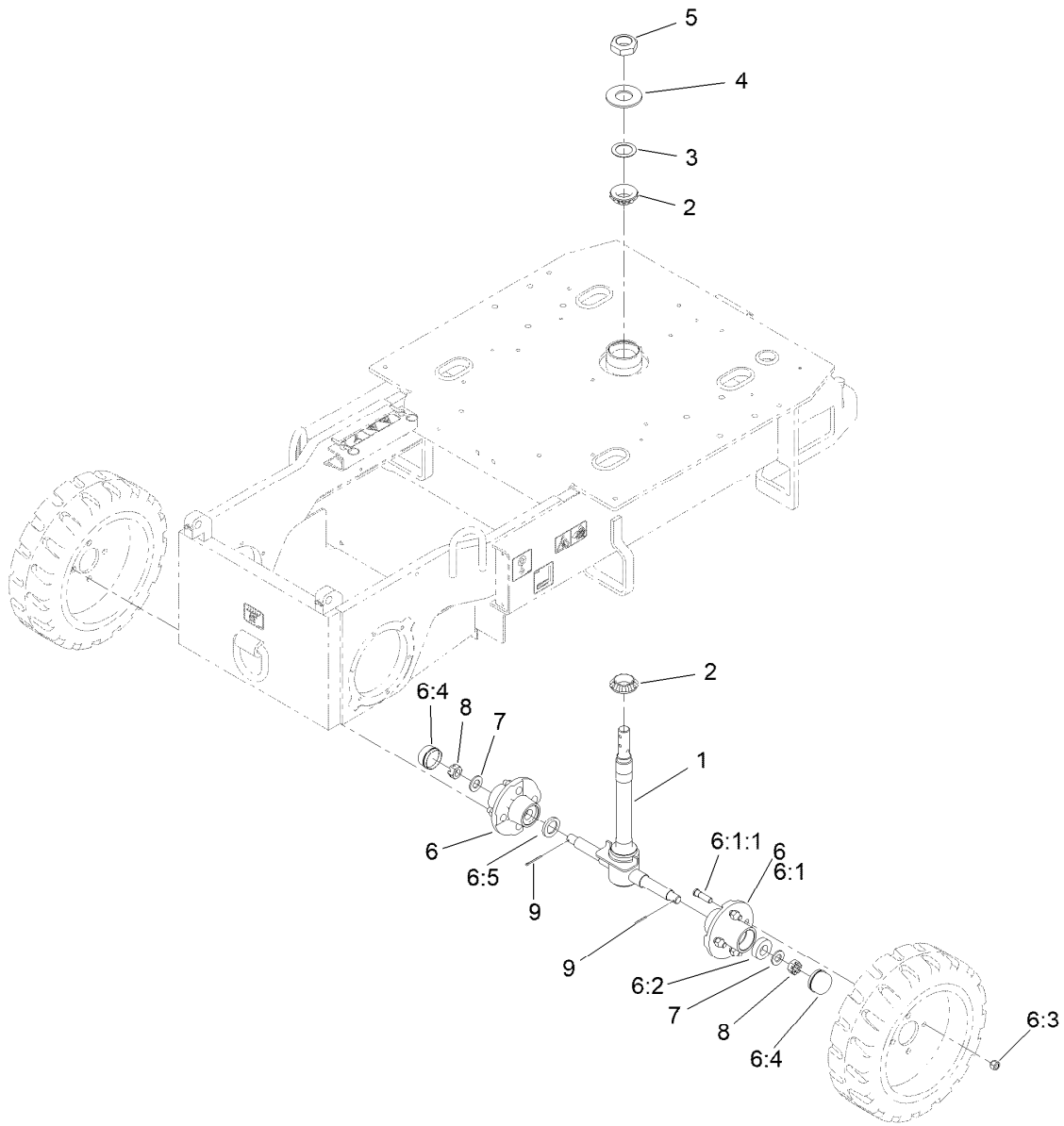

Steering Assembly

Ref.	Part Number	Qty.	Description
1	145-4992-0P	1	Axle-Steering [primed]
2	ST32161	2	Bearing-Roller
3	ST81109	1	Washer-Thrust
4	ST36934	1	Plate-Cover, Bearing
5	ST81108	1	Nut
6	139-1328	2	Hub ASM
6:1	139-1327	1	Hub-4In
6:1:1	ST39190	4	Stud-Wheel
6:2	ST32233	2	Bearing-Roller
6:3	ST80045	4	Nut-Lug
6:4	ST34573	1	Cap-Dust
6:5	ST32052	1	Seal-Hub, Wheel
7	3256-28	2	Washer-Flat
8	ST80054	2	Nut
9	3272-13	2	Pin-Cotter

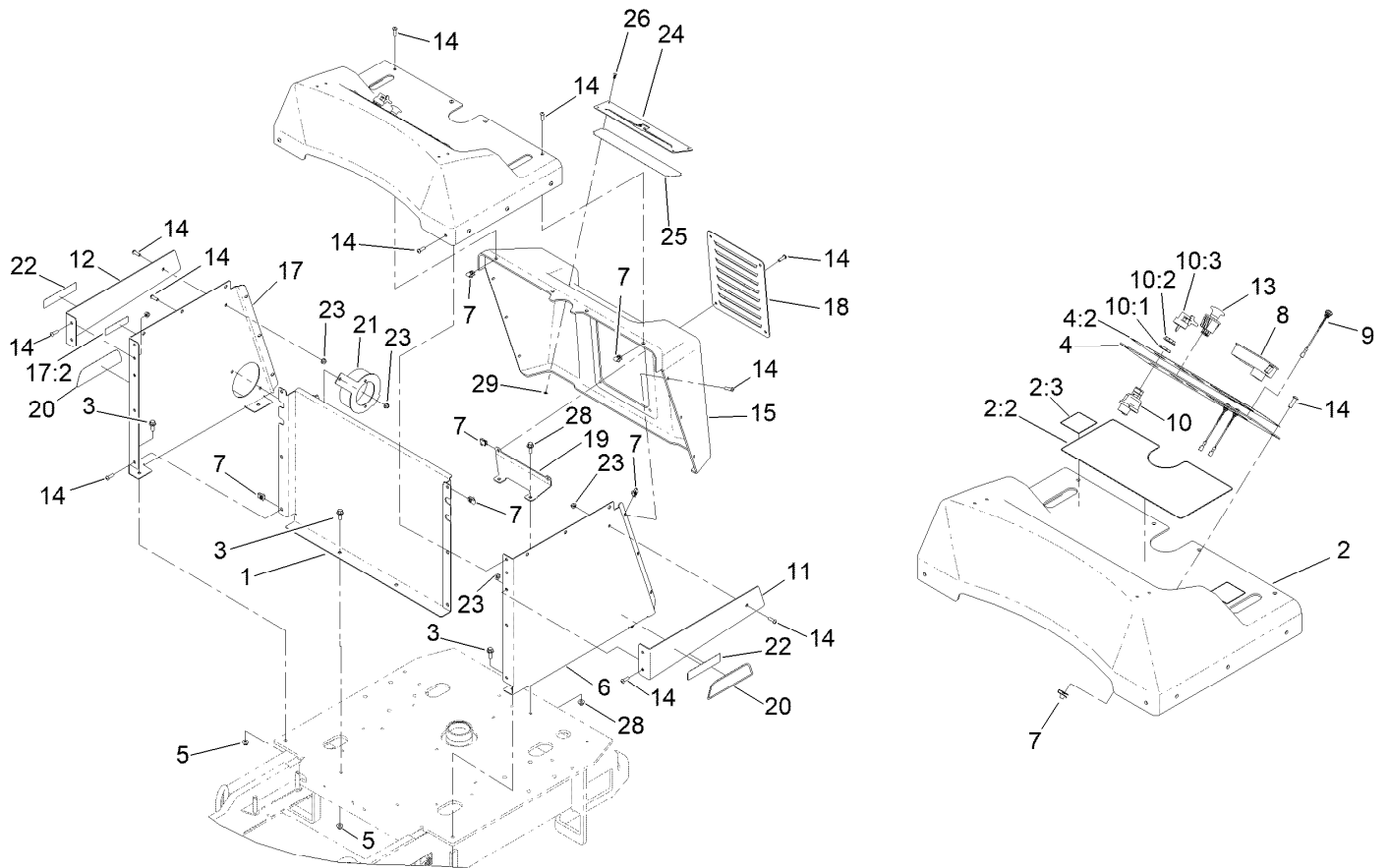

Tower and Hood Assembly

Ref.	Part Number	Qty.	Description	Ref.	Part Number	Qty.	Description
1	144-1652-03	1	Panel-Tower,Front	12	145-4986-03	1	Plate-Decal [black]
2	147-3219	1	Dash Panel ASM	13	136-6888	1	Switch, E-Stop
2:2	145-1168	1	Decal-Control Panel	14	109-4872	38	Screw-HSH
2:3	125-4967	2	Decal-Lift Here	15	144-1773	1	Hood
3	3234-42	6	Screw-HHF	17	147-3221	1	Access Panel ASM, RH
4	147-3220	1	Display Cover ASM	17:2	145-1175	1	Decal-Service, Shut-Off
4:2	145-1169	1	Decal-Control Panel	18	144-1735-03	1	Cover-Access, Bms
5	119-4042	6	Nut-HF, NI	19	144-1774-03	1	Bracket-Hood
6	144-1662-01	1	Panel-Access, LH	20	145-1172	2	Decal-Hypercell
7	94-2413	30	Nut-U	21	147-3208-03	1	Bracket-Disconnect [black]
8	122-2152	1	Controller, Tdm-1601	22	145-1171	2	Decal-E2500
9	136-9678	3	Switch-Pushbutton	23	104-8300	8	Nut-HF, NI
10	122-2513	1	Switch-Ignition, Suns	24	147-3203-03	1	Plate-Logo
10:1	121-5160	1	Nut-Hex ●	25	145-1184	1	Decal-Backer, Red
10:2	122-2704	1	Nut-Face, M22 (Plastic)	26	3269-28	4	Rivet-Pop
10:3	121-5162	1	Set-Key, Ignition	28	110-9380	2	Screw-HWH
11	145-4985-03	1	Plate-Decal [black]	29	3269-26	4	Washer-Plain

● Not illustrated

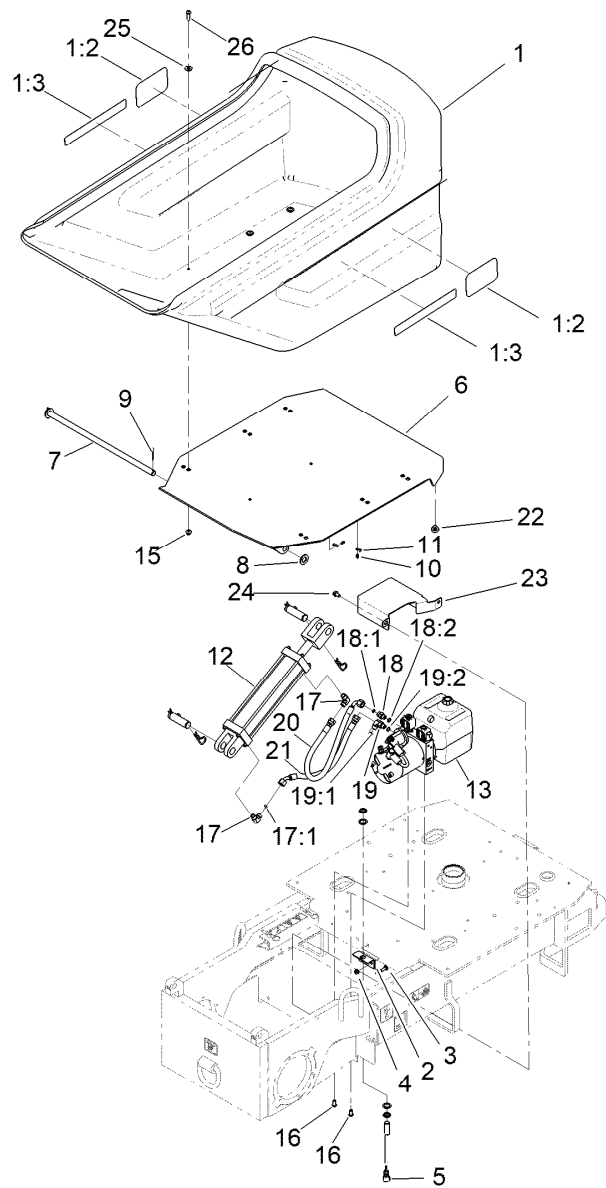

Tub Assembly

Ref.	Part Number	Qty.	Description	Ref.	Part Number	Qty.	Description
1	144-1762	1	Mortar Hopper ASM	16	3274-80	2	Screw-HH
1:2	105-1217	2	Decal	17	340-112	2	Fitting-Elbow, 90
1:3	139-7237	2	Decal - E-Mud Buggy	17:1	237-22	1	O-Ring
2	144-1706	1	Bracket-Switch	18	340-2	1	Fitting-Straight
3	3230-2	2	Bolt-CARR	18:1	237-22	1	O-Ring
4	104-8300	2	Nut-HF, NI	18:2	237-42	1	O-Ring
5	139-7238	1	Sensor-Proximity, N.O.	19	340-77	1	Fitting-Elbow, 90 DEG
6	144-1698-03	1	Dump Bin Frame ASM-Welded	19:1	237-22	1	O-Ring
7	144-1709	1	Shaft-Dump Pivot	19:2	237-42	1	O-Ring
8	3256-28	2	Washer-Flat	20	144-1736	1	Hose ASM-HYD
9	3272-13	2	Pin-Cotter	21	144-1737	1	Hose ASM-HYD
10	302-5	3	Fitting-Grease	22	140-3460	2	Bumper-Rubber
11	ST47001	3	Cap-Plug	23	147-3217-03	1	Cover-Contact
12	ST50501	1	HYD Cylinder ASM	24	32144-69	2	Screw-HWHTF
13	144-1716	1	Pump Unit-48 Vdc	25	3256-4	6	Washer-Flat
15	104-8301	6	Nut-HF, NI	26	3274-63	6	Screw-HSBH

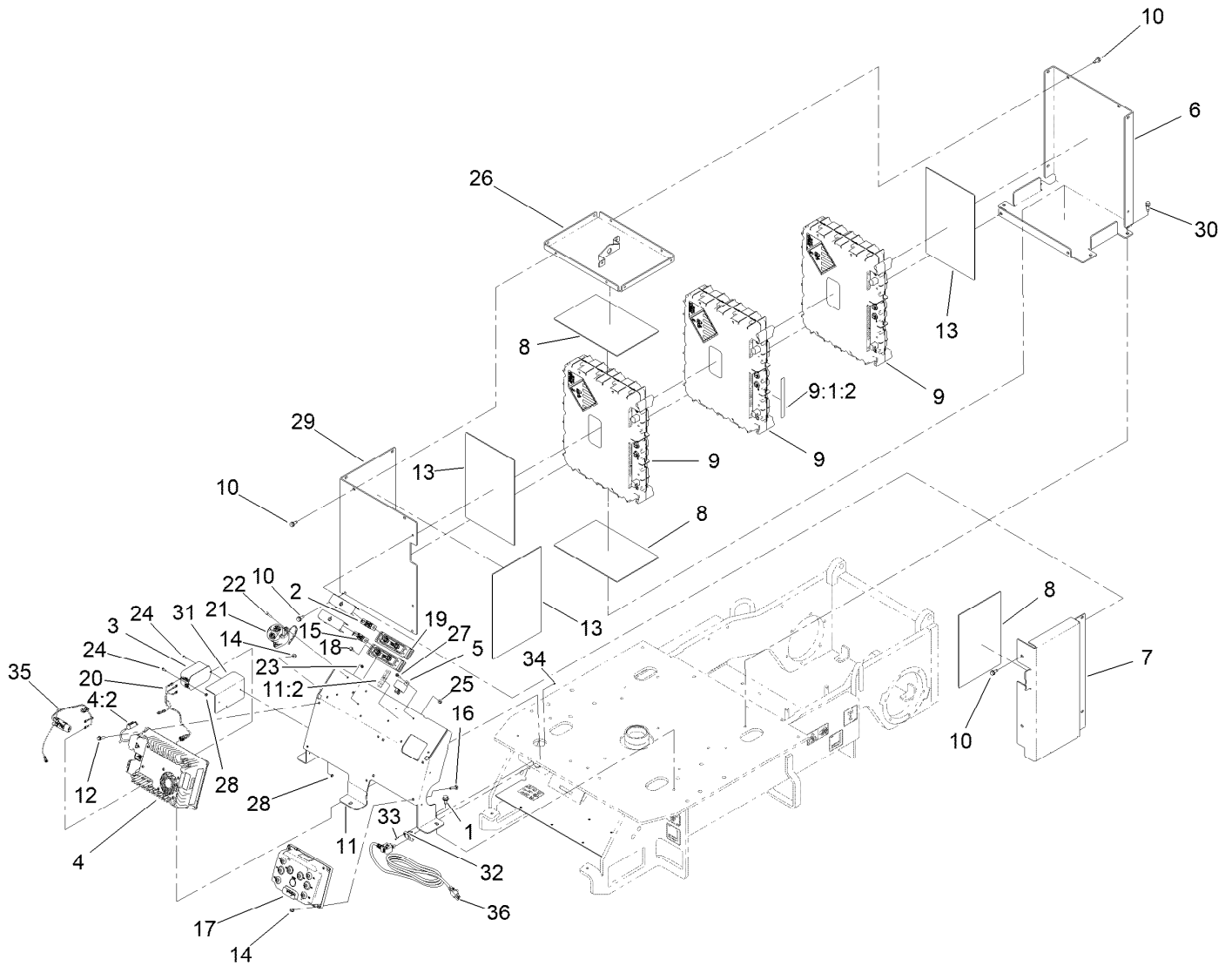

Battery Assembly

Ref.	Part Number	Qty.	Description	Ref.	Part Number	Qty.	Description
1	110-9380	3	Screw-HWH	18	32144-4	4	Screw-HWH
2	122-2561	1	Fuse-200A	19	145-4958	2	Holder-Fuse
3	147-3225	1	Filter	20	122-2745	1	Harness-Wire, AC Charger
4	145-1177	1	Charger-Onboard	21	122-2594	1	Contactora-48V
4:2	147-3234	1	Kit-Service, DC Harness	22	87-5150	2	Screw-HH
5	122-2401	1	Relay, 48V Coil, 50A At 48V	23	87-5140	2	Nut-Lock
6	145-4919-0P	1	Mount-Battery, Base	24	3250-26	3	Screw-PPH
7	145-4995-0P	1	Cover-Battery, Side	25	120-4578	1	Nut-HF
8	145-4925	3	Pad-Foam	26	147-3202-0P	1	Cover-Battery [primed]
9	145-5320	3	Battery ASM	27	32105-13	1	Screw-HWH
9:1:2	145-5338	1	Decal-Warning, Battery	28	3296-54	3	Nut-Lock
10	32144-11	13	Screw-HWH	29	145-4993-0P	1	Cover-Battery, Side
11	147-3223	1	Bracket-Electrical	30	121-5844	4	Screw-Thd Form, HWH
11:2	145-1173	1	Decal-Fuse	31	147-3216-0P	1	Bracket-Filter
12	119-1066	4	Screw-HF	32	147-3230	1	Connector-lec
13	145-4926	3	Pad-Foam	33	360-0224	2	Screw
14	119-4040	8	Nut-HF, NI	34	3296-52	2	Nut-Lock, NI
15	122-2627	1	Fuse-70A	35	122-2744	1	Harness-Wire, AC Charger
16	3229-3	4	Screw-CARR	36	137-7983	1	Cord-AC, 120V
17	138-8984	1	Inv/Ctrlr-48V,Dual 94Arms				

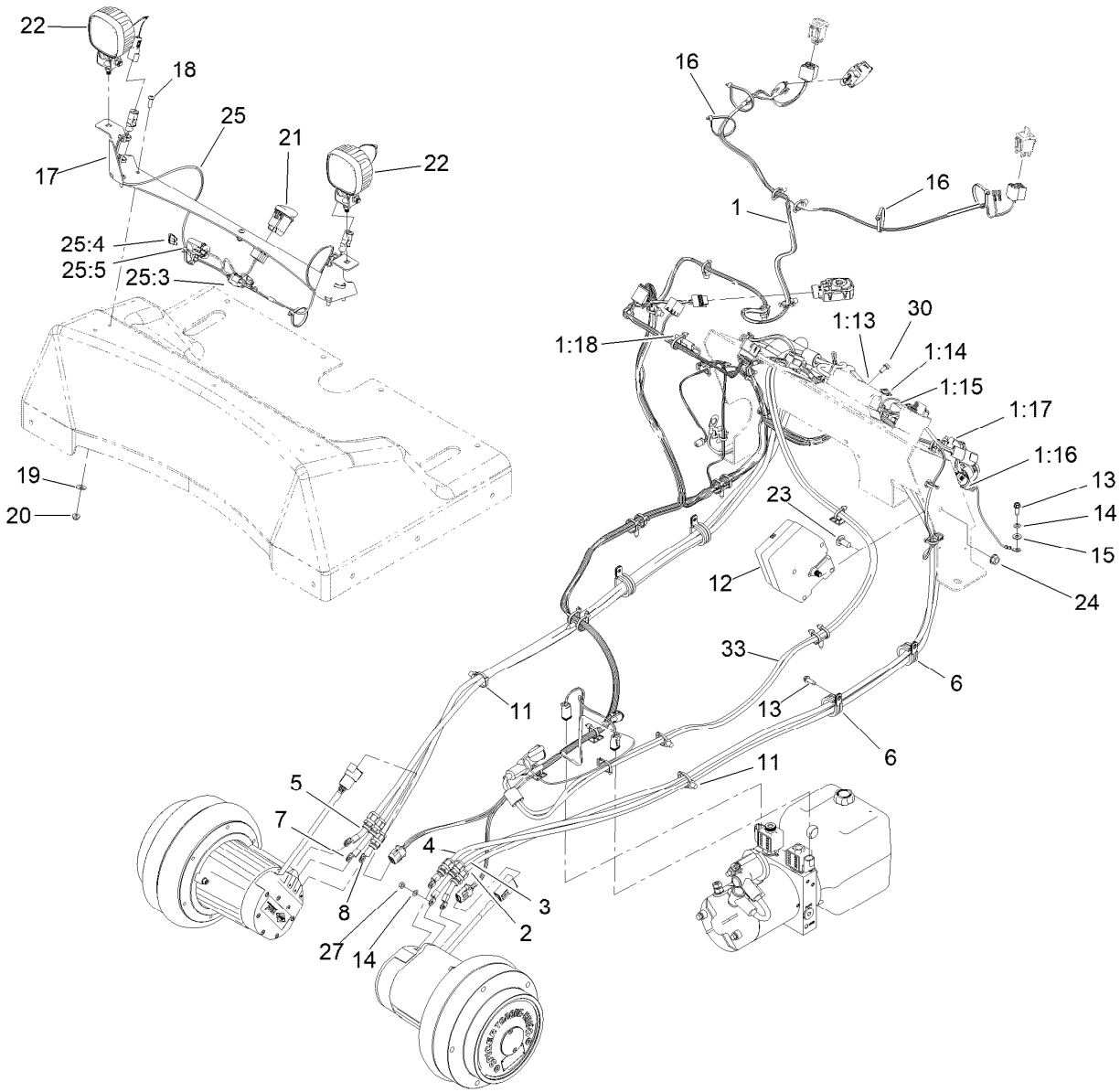

Harness Assembly

Ref.	Part Number	Qty.	Description	Ref.	Part Number	Qty.	Description
1	122-2507	1	Harness-Wire, Main	15	120-9679	1	Washer-Flat
1:13	117-4722	1	Fuse-Blade, 5A	16	3290-378	10	Tie-Cable
1:14	117-4724	1	Fuse-Blade, 10A	17	144-7138-03	1	Bracket-Mount,Light [black]
1:15	32180-567	2	Cover-Aptiv, Modified	18	3274-69	5	Screw-HSBH
1:16	32180-282	1	Resistor-120 Ohm	19	3256-2	5	Washer-Flat
1:17	32180-089	1	Cap-Plug, 3 Way	20	104-7201	5	Nut-HF, NI
1:18	116-0053	1	Cap-Plug	21	112-9421	1	Switch
2	122-2602	1	Cable-Battery, Rd ASM	22	147-3261	2	Light-Work
3	122-2603	1	Cable-Battery, Rd ASM	23	3231-27	1	Screw-CARR
4	122-2604	1	Cable-Battery, Rd ASM	24	3290-357	1	Nut-HSF
5	122-2605	1	Cable-Battery, Rd ASM	25		1	Harness-Wire, Light Kit ●
6	120-2037	4	R-Clamp	25:3	32180-091	1	Cap-Dust, 2 Way
7	122-2606	1	Cable-Battery, Rd ASM	25:4	117-4720	1	Fuse-Blade, 3A
8	122-2607	1	Cable-Battery, Rd ASM	25:5	32180-567	1	Cover-Aptiv, Modified
11	32180-030	3	Clip-Tie	27	HDW21408	6	Nut-Hex
12	145-4982	1	Horn	30	145-5782	6	Screw-Sems
13	49-2040	5	Screw-HWHTF	33	122-2791	1	Cable-Battery, Rd And Bk ASM
14	1-303435	7	Washer-Spring				

● Not serviced separately

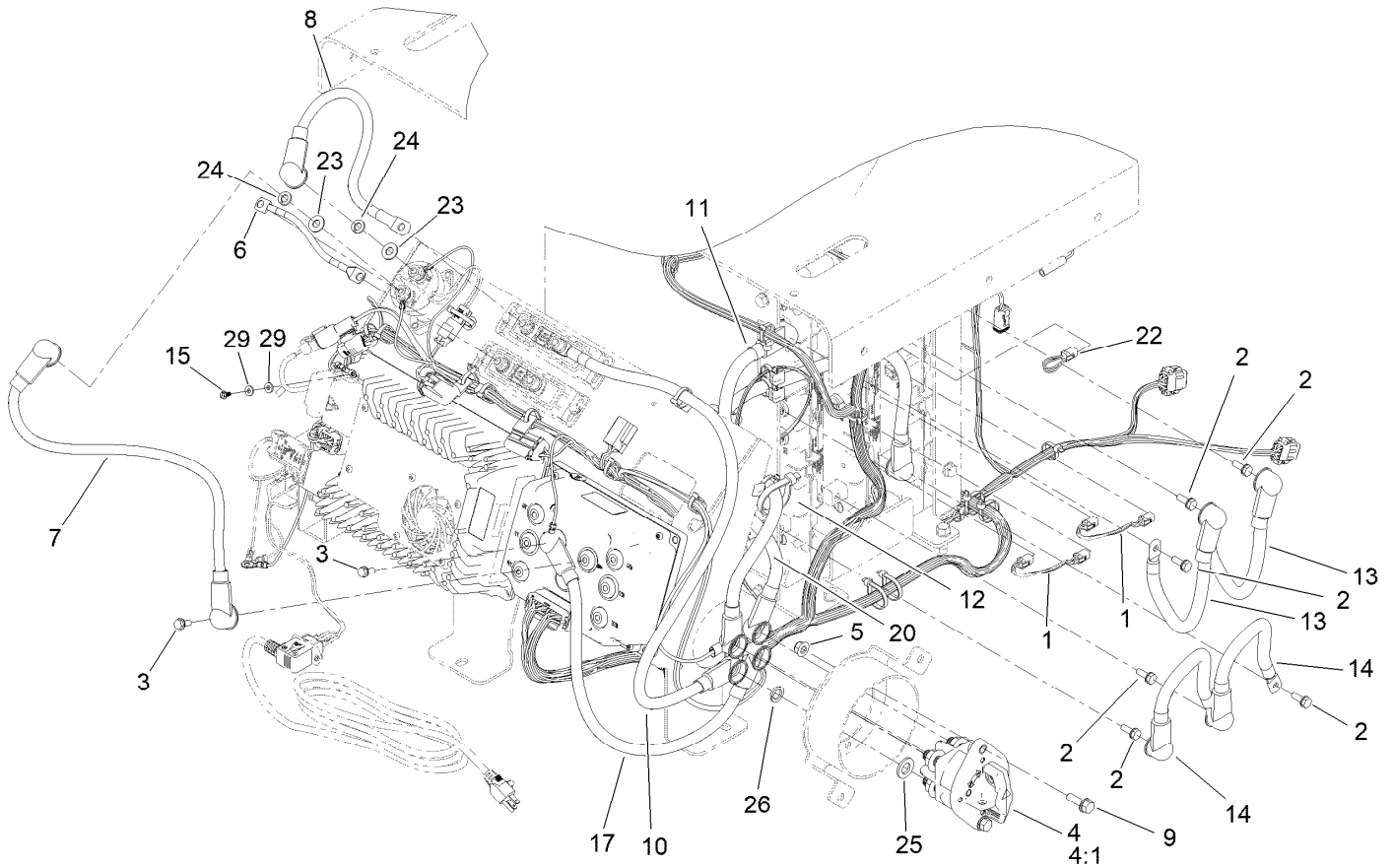

Battery Cable Assembly

Ref.	Part Number	Qty.	Description	Ref.	Part Number	Qty.	Description
1	140-9565	2	Harness-Wire, Data Interface	13	145-7182	2	Cable-Battery,Rd ASM
2	145-5783	6	Screw-Sems	14	145-7183	2	Cable-Battery,Bk ASM
3	145-5782	2	Screw-Sems	15	147-3228	1	Screw-Ground
4	122-0603	1	Switch-Disconnect	17	122-2707	1	Cable-Battery, Bk ASM
4:1	33006-00	1	Nut-HF	20	122-2706	1	Cable-Battery, Bk ASM
5	104-8300	2	Nut-HF, NI	22	122-2323	1	Harness-Wire, Can Terminator
6	122-2610	1	Cable-Battery, Rd ASM	23	107-0279	2	Washer
7	122-2611	1	Cable-Battery,Rd ASM	24	107-0280	2	Washer-Lock
8	122-2612	1	Cable-Battery,Rd ASM	25	147-3238	4	Washer-Flat
9	3234-29	2	Screw-HHF	26	HDW14457	4	Split Lock Washer,1/2,ST/ST,18-8
10	122-2717	1	Cable-Battery, Rd ASM	29	3256-21	2	Washer-Flat
11	122-2718	1	Cable-Battery, Rd ASM	99	3290-379	1	Tie-Cable ●
12	3334-945	1	Tie-Cable				

● Not illustrated

Attachments and Accessories

For 68037 Ultra Buggy e2500

Product Name	Model/Part
Toro Red 12oz Aerosol Can	361-10
New Red Paint - Gallon	361-11
Semi-Gloss Black Spray Paint	361-9
Dual Wheel Kit, Elec Wheeled Ultra Buggy	68022
Steel Tub Accessory For Material Buggies	68101

Notes:



Count on it.