



# Tru Trak™ Sulky

## ProLine Mid Size Mower Attachment

Model No. 30110—220000001 and Up

## Parts Catalog

### Ordering Replacement Parts

To order replacement parts, please supply: the part number, the quantity, and the description of each part desired.

### Understanding Reference Numbers

Each identified part in an illustration has a reference number. The reference number for a part also appears in the parts list, along with other information about the part.

This catalog uses two special reference number formats, one to indicate parts in a service assembly and another to indicate the quantity of a given part in an illustration.

### Service Assembly Reference Numbers

Parts in service assemblies have reference numbers in the form **a:b**. The **a** represents the reference number of the entire service assembly and the **b** represents a sequential number unique to each part within the service assembly.

For example, a wheel assembly might be identified by reference number **6**, the tire by **6:1**, the valve by **6:2**, and the wheel by **6:3**. When you order the assembly identified by reference number **6**, you receive all parts identified by reference numbers **6:1**, **6:2**, and **6:3**. However, you may also order any part individually.

Reference numbers of this type appear in illustrations and in part lists.

### Reference Numbers Indicating Quantity

In an illustration, if a reference number indicates more than one part, the reference number has the form **nX y**. The **n** represents the quantity of the part, the **X** is the multiplication symbol, and the **y** represents the reference number.

For example, in an illustration, the reference number **2X 37** means that two of the parts identified by reference number **37** are indicated.

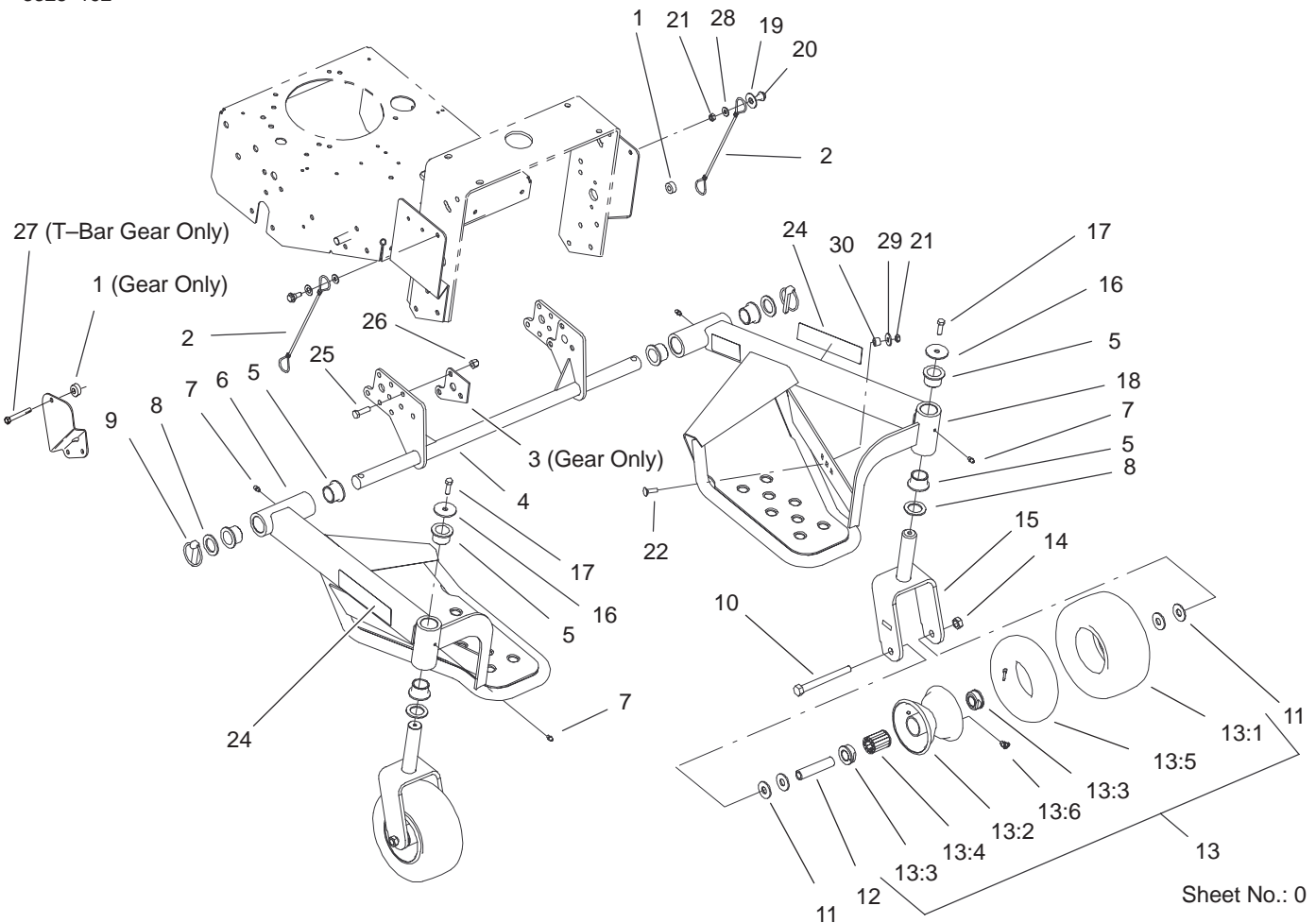

Sheet No.: 0

## Sulky Assembly

Ref. No.	Part No.	Qty.	Description
1	104-8426	2	Spacer
2	93-9595	2	Lanyard
3	104-8425-01	2	Plate-Spacer
4	104-8405-01	1	Axle ASM
5	94-1291	8	Bushing-Special
6	104-8407-01	1	LH Floor Plate ASM
7	302-5	4	Fitting-Grease
8	3-6781	4	Washer-Thrust
9	283-71	2	Pin-Lynch
10	325-19	2	Screw-HH
11	3256-6	8	Washer-Flat
12	68-8980	2	Spanner-Tire
13	99-1268	2	Castor Wheel ASM
13:1	93-9939	1	Tire
13:2	100-2348	1	Rim ASM
13:3	62-5580	2	Bearing-Outside
13:4	62-5570	1	Bearing-Roller
13:5	100-5832	1	Tube W/ Valve
13:6	302-11	1	Fitting-Lube, 45°
14	32153-5	2	Nut-Lock
15	104-8402-01	2	Castor ASM
16	63-7400	2	Washer-Rebound
17	322-16	2	Screw-HH
18	104-2743-01	1	RH Floor Plate ASM
19	3256-5	2	Washer-Flat
20	94-7817	2	Bolt-Shoulder

Ref. No.	Part No.	Qty.	Description
21	3296-47	4	Nut-Lock, NI
22	3230-2	2	Screw-CARR
24	104-8477	2	Decal
25	323-29	6	Screw-HH
26	3296-39	6	Nut-Lock, NI
27	323-23	2	Screw-HH
28	3256-3	2	Washer-Flat
29	1-603716	2	Washer-Friction
30	98-4695	2	Spacer