



Count on it.

Parts Catalog

**Workman® MDX
Lithium Utility Vehicle**

Model No. 08303—Serial No. 40000000 and Up



Ordering Replacement Parts

To order replacement parts, please supply the part number, the quantity, and the description of each part desired.

Understanding Reference Numbers

Each identified part in an illustration has a reference number. The reference number for a part also appears in the parts list, along with other information about the part.

This catalog uses two special reference number formats, one to indicate parts in a service assembly and another to indicate the quantity of a given part in an illustration.

Service Assembly Reference Numbers

Parts in service assemblies have reference numbers in the form a:b. The a represents the reference number of the entire service assembly and the b represents a sequential number unique to each part within the service assembly.

For example, a wheel assembly might be identified by reference number 6, the tire by 6:1, the valve by 6:2, and the wheel by 6:3. When you order the assembly identified by reference number 6, you receive all parts identified by reference numbers 6:1, 6:2, and 6:3. However, you may also order any part individually. Reference numbers of this type appear in illustration and in parts lists.

Reference Numbers Indicating Quantity

In an illustration, if a reference number indicates more than one part, the reference number has the form nX y. The n represents the quantity of the part, the X is the multiplication symbol, and the y represents the reference number.

For example, in an illustration, the reference number 2X 37 means that two of the parts identified by reference number 37 are indicated.

Contents

Front Frame and Suspension Assembly	4
Rear Frame and Suspension Assembly	6
Front Brake Assembly	8
Master Cylinder Assembly No. 104-6782	10
Brake Caliper Assembly No. 161-1890	11
Rear Brake Assembly	12
Steering Assembly	14
Accelerator and Brake Pedal Assembly	16
Hood and Fenders Assembly	18
Dash Assembly	20
Seatbase Assembly	22
Cargo Bed Assembly	24
Cargo Bed Service Assembly No. 147-4026	26
Battery and Transaxle Assembly	28
Transaxle Assembly No. 147-3858	30
Electric Motor Assembly No. 137-6936	32
Electrical Assembly	34
Wire Harness Assembly No. 122-2478	36
Attachments and Accessories	38

Front Frame and Suspension Assembly

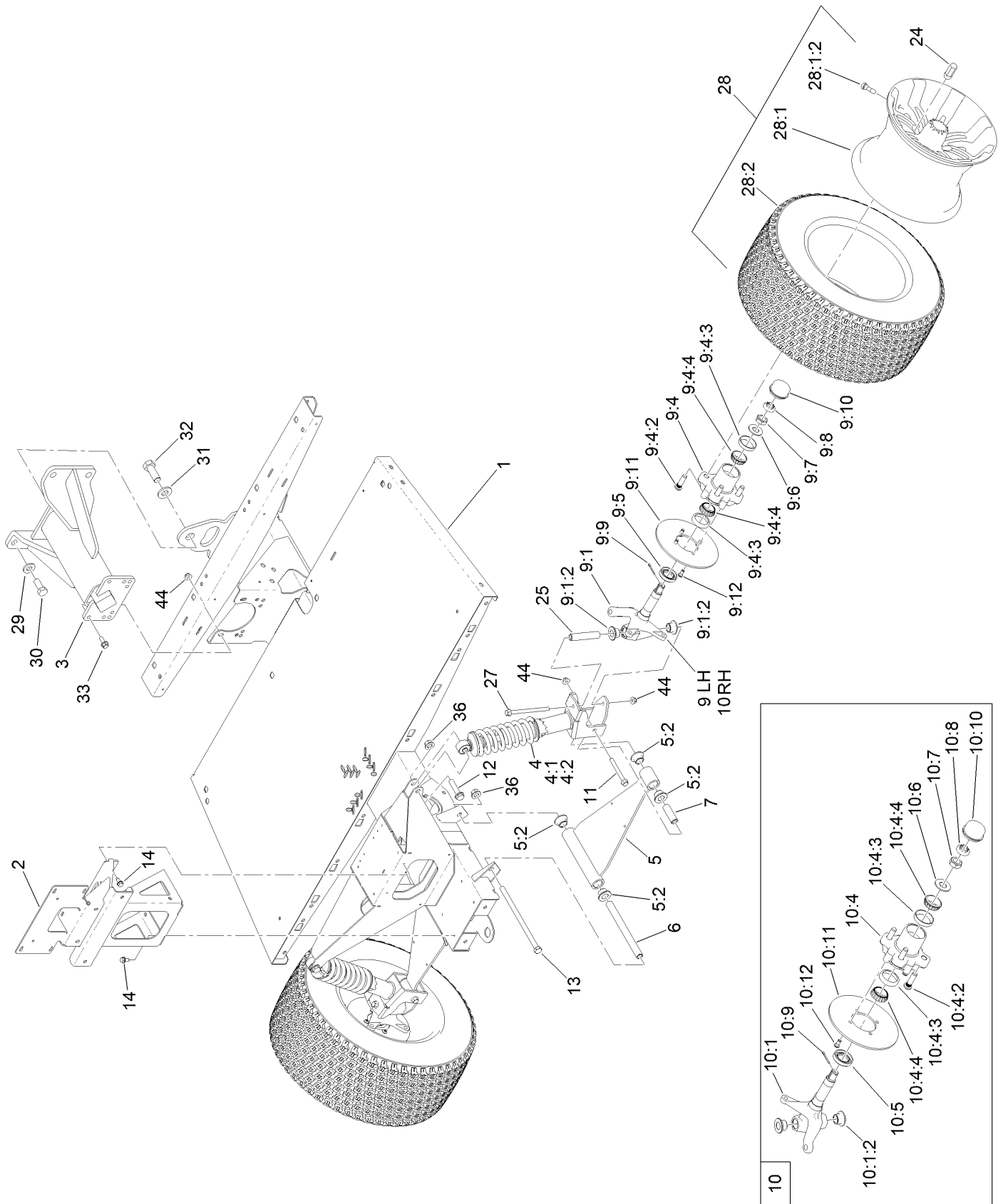

Front Frame and Suspension Assembly (continued)

<i>Ref.</i>	<i>Part Number</i>	<i>Qty.</i>	<i>Description</i>	<i>Ref.</i>	<i>Part Number</i>	<i>Qty.</i>	<i>Description</i>
1	161-1945-03	1	Front Frame ASM [black]	10:4:2	10-6830	4	Stud-Type, Drive
2	132-6736-03	1	Support-Bumper	10:4:3	254-72	2	Bearing-Cup, Tapered
3	99-7700	1	Yoke-Pivot	10:4:4	254-94	2	Bearing-Cone, Tapered
4	132-6791	2	Strut ASM	10:5	112-1690	1	Seal-Oil
4:1	133-0556	1	Spring-Coil	10:6	93-0309	1	Washer-Tab
4:2	131-8574	1	Isolator-Shock	10:7	3220-7	1	Nut-Jam
5	144-2160	2	Control Arm ASM	10:8	93-0307	1	Nut-Lock, Retainer
5:2	140-4615	4	Bushing-Flange	10:9	3272-12	1	Pin-Cotter
6	133-0595	2	Sleeve-Control Arm, Inner	10:10	241-119	1	Cap-Dust
7	131-8583	2	Sleeve-Control Arm, Outer	10:11	139-4474	1	Rotor-Brake
9	140-9835	1	LH Spindle ASM	10:12	121-9671	4	Screw-HSBH
9:1	144-5468	1	Spindle ASM LH	11	139-3370	2	Screw-HF
9:1:2	140-4615	2	Bushing-Flange	12	3234-46	2	Screw-HHF
9:4	144-5470	1	Front Hub ASM	13	325-39	2	Screw-HH
9:4:2	10-6830	4	Stud-Type, Drive	14	32144-70	6	Screw-HWHTF
9:4:3	254-72	2	Bearing-Cup, Tapered	24	139-3603	8	Nut-Lug
9:4:4	254-94	2	Bearing-Cone, Tapered	25	131-8582	2	Sleeve-Kingpin
9:5	112-1690	1	Seal-Oil	27	139-3350	2	Screw-HF
9:6	93-0309	1	Washer-Tab	28	147-3969	2	Wheel And Tire ASM
9:7	3220-7	1	Nut-Jam	28:1	147-3967	1	Wheel-Aluminum
9:8	93-0307	1	Nut-Lock, Retainer	28:1:2	232-27	1	Stem-Valve
9:9	3272-12	1	Pin-Cotter	28:2	120-3271	1	Tire
9:10	241-119	1	Cap-Dust	29	99-7667	4	Washer-Flat
9:11	139-4474	1	Rotor-Brake	30	327-4	4	Screw-HH
9:12	121-9671	4	Screw-HSBH	31	87-3060	1	Washer-Hardened
10	140-9836	1	RH Spindle ASM	32	328-24	1	Screw-HH
10:1	144-5469	1	Spindle ASM RH	33	131-2220	4	Screw-HHF
10:1:2	140-4615	2	Bushing-Flange	36	99-5107	4	Nut-Lock
10:4	144-5470	1	Front Hub ASM	44	139-3380	8	Nut-HF

Rear Frame and Suspension Assembly

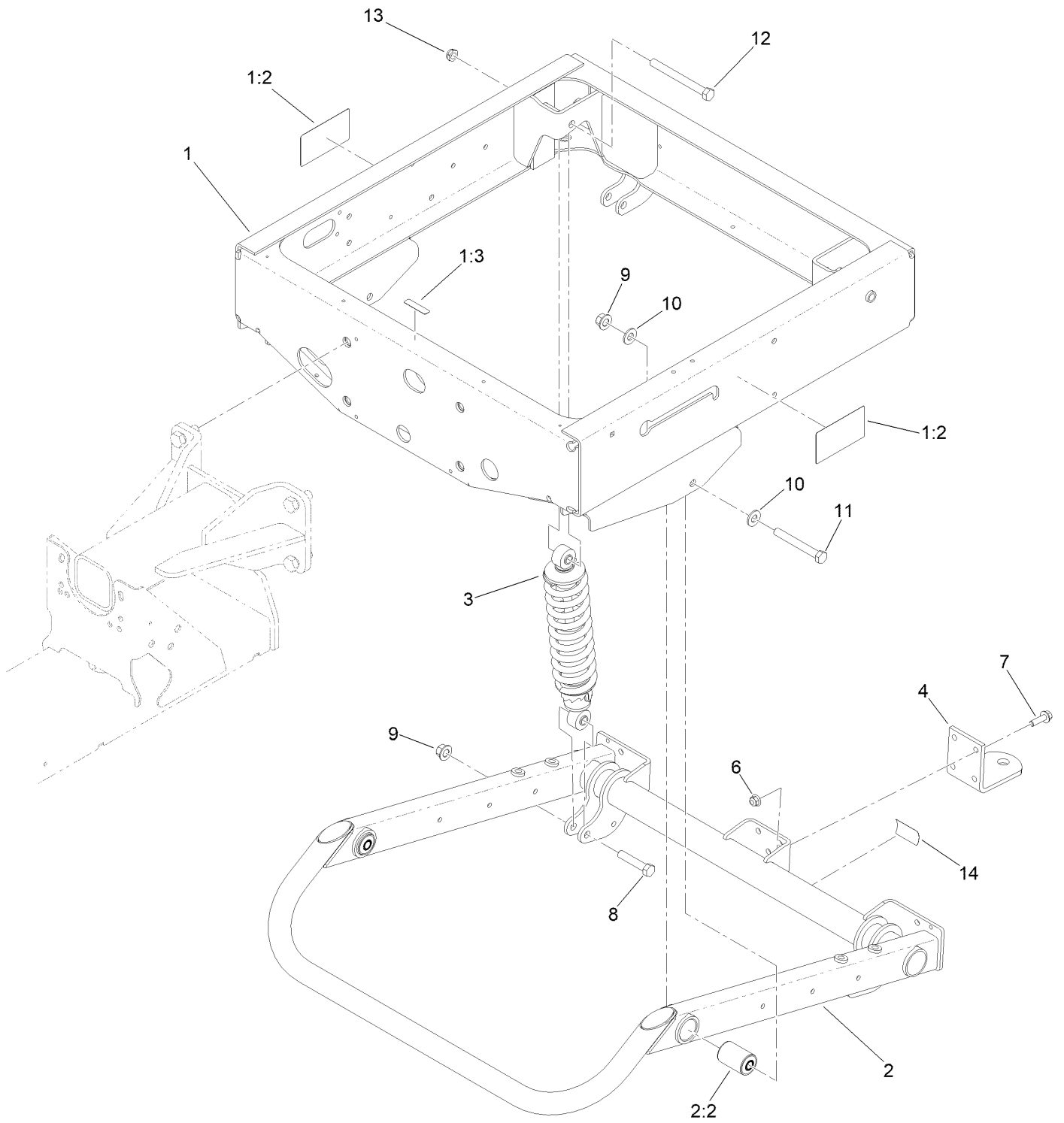

Rear Frame and Suspension Assembly (continued)

<i>Ref.</i>	<i>Part Number</i>	<i>Qty.</i>	<i>Description</i>	<i>Ref.</i>	<i>Part Number</i>	<i>Qty.</i>	<i>Description</i>
1	147-3869	1	Rear Frame ASM	7	3234-24	4	Screw-HHF
1:2	147-4081	2	Decal-Safety MDX-Lithium, Rear	8	325-10	2	Screw-HH
1:3	120-9570	1	Decal-Warning	9	99-5107	4	Nut-Lock
2	147-3866	1	Swing Arm ASM	10	87-7270	4	Washer-Thrust
2:2	112-3377	2	Bushing-Arm, Control	11	325-17	2	Screw-HH
3	133-0553	2	Shock And Spring ASM	12	325-19	2	Screw-HH
4	99-7654-03	1	Hitch-Duty, Light	13	3296-45	2	Nut-Hex
6	104-8301	4	Nut-HF, NI	14	136-1164	1	Decal-Load, Towing

Front Brake Assembly

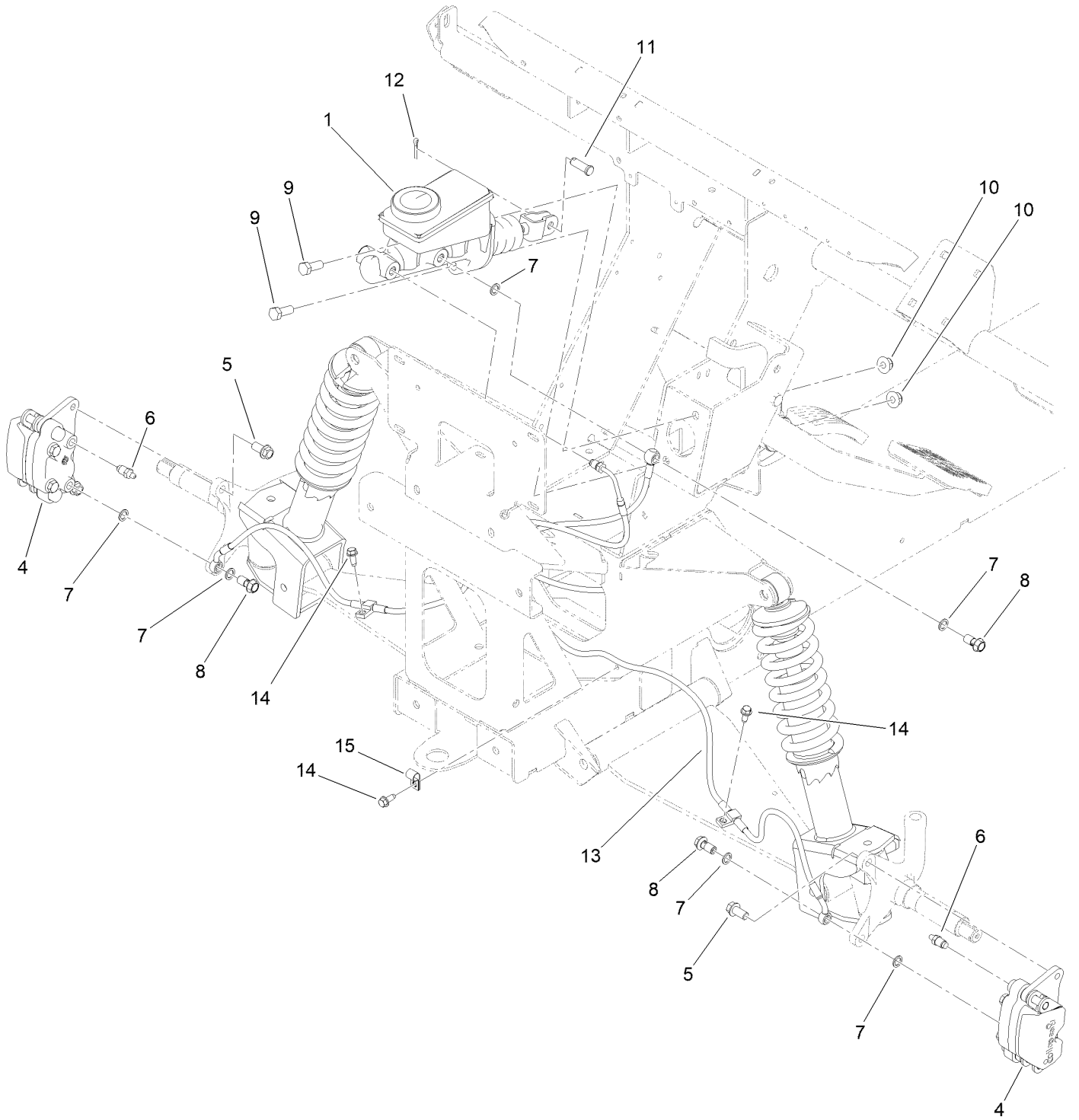

Front Brake Assembly (continued)

<i>Ref.</i>	<i>Part Number</i>	<i>Qty.</i>	<i>Description</i>	<i>Ref.</i>	<i>Part Number</i>	<i>Qty.</i>	<i>Description</i>
1	104-6782	1	Master Cylinder ASM	10	104-8301	2	Nut-HF, NI
4	161-1890	2	Brake Caliper ASM	11	283-2	1	Pin-Clevis
5	144-5550	4	Screw-Spl	12	3272-10	1	Pin-Cotter
6	119-9509	2	Screw-Bleed	13	132-6793	1	Line-Brake, Front
7	115-2341	6	Washer-Banjo	14	32144-10	4	Screw-HWH
8	120-4875	3	Bolt-Flange, Banjo	15	2412-89	1	Clamp-R
9	323-6	2	Screw-HH				

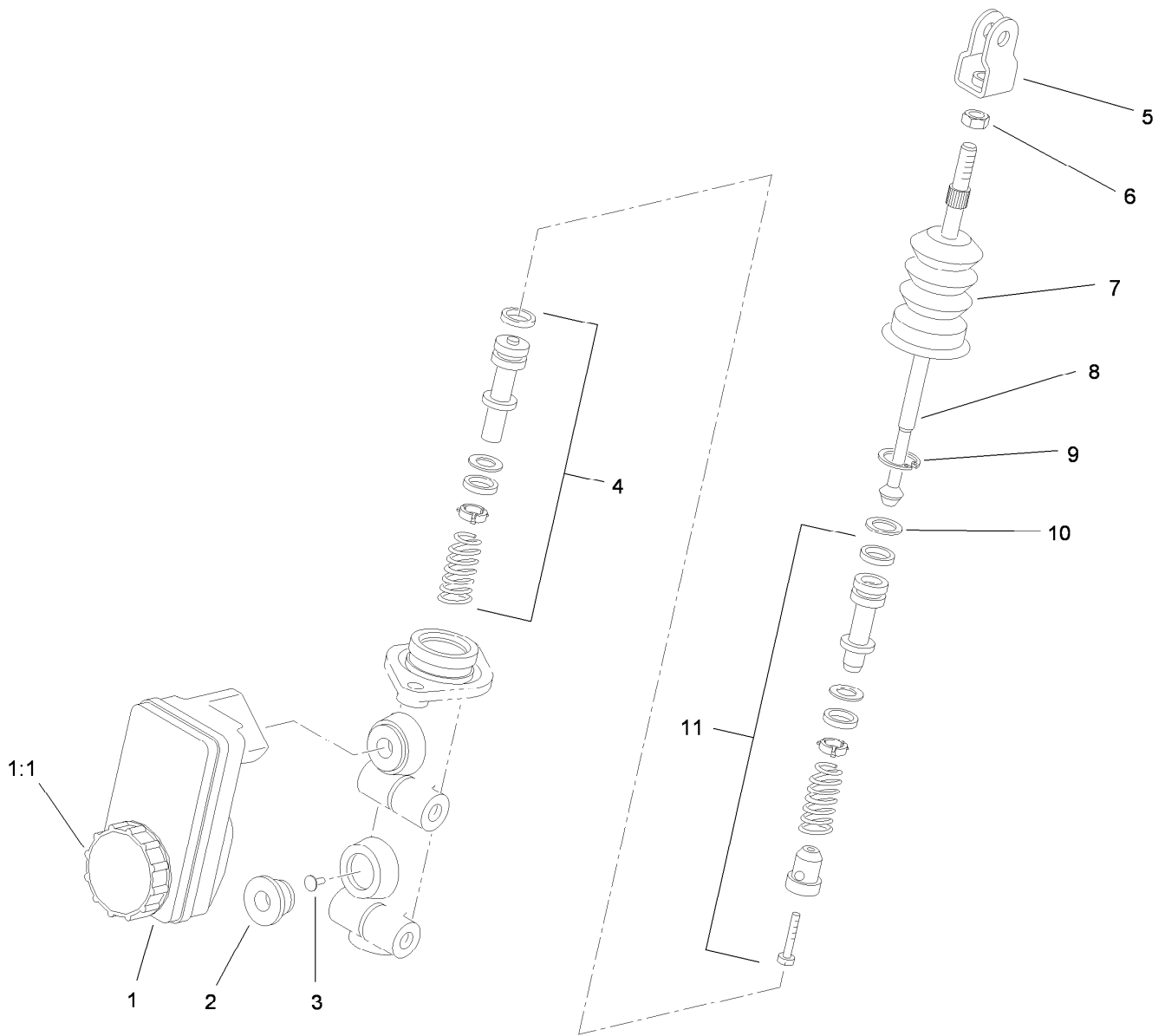

Master Cylinder Assembly No. 104-6782

Ref.	Part Number	Qty.	Description
1	104-6845	1	Reservoir ASM
1:1	92-4112	1	Cap ASM
2	93-8971	2	Seal-Port, Flange
3	92-4103	1	Pin-Stop
4	92-4102	1	Secondary Piston ASM
5	92-4110	1	Clevis
6	21-0360	1	Nut-Hex
7	94-5209	1	Cover-Dust
8	94-5210	1	Rod-Push
9	92-4109	1	Ring-Snap
10	92-4108	1	Retainer-Washer
11	92-4101	1	Primary Piston ASM

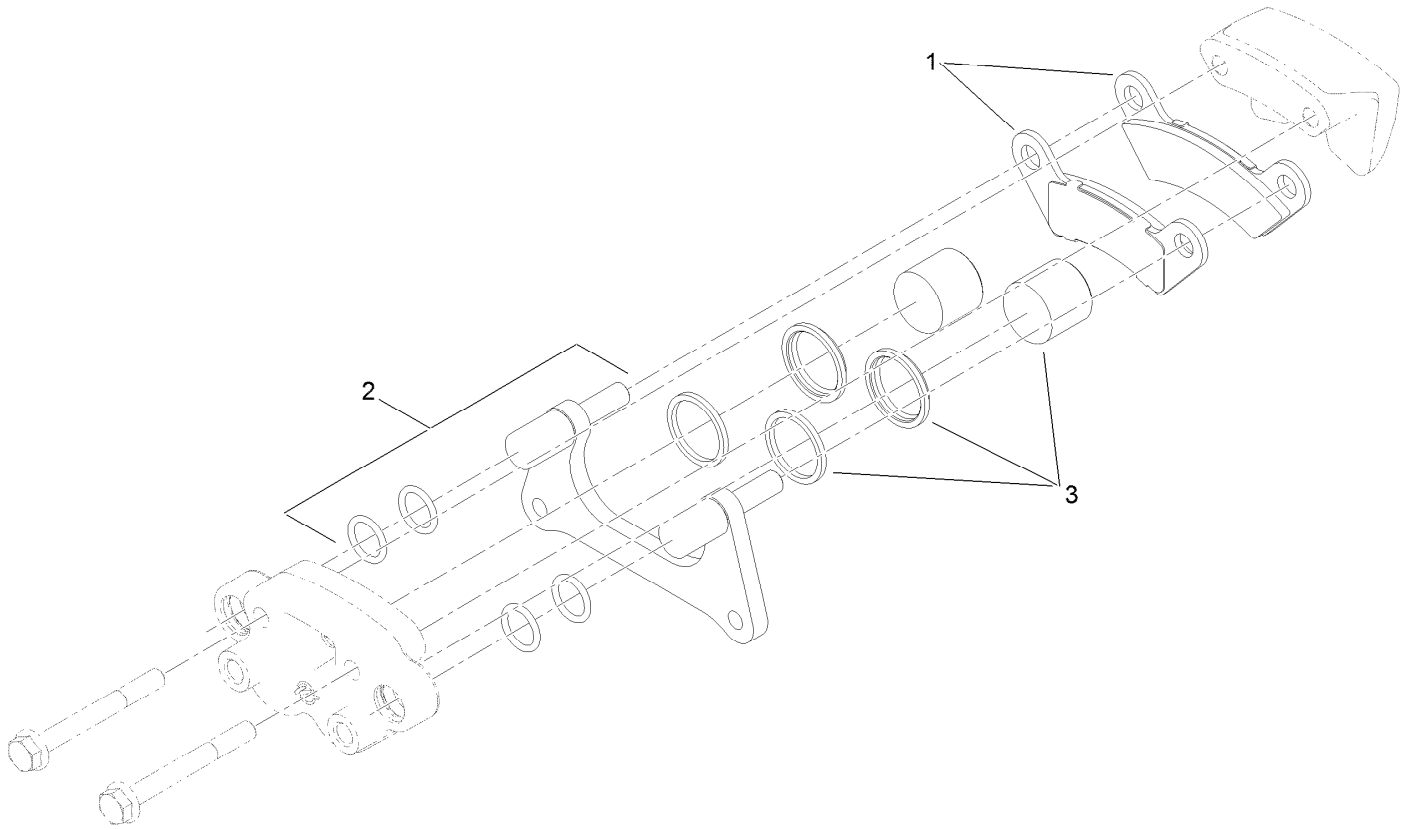

Brake Caliper Assembly No. 161-1890

<i>Ref.</i>	<i>Part Number</i>	<i>Qty.</i>	<i>Description</i>
1	140-2580	1	Brake Pad Service Kit (Front, Qty 4)
2	119-9511	1	Bracket Kit
3	133-0614	1	Piston Kit

Rear Brake Assembly

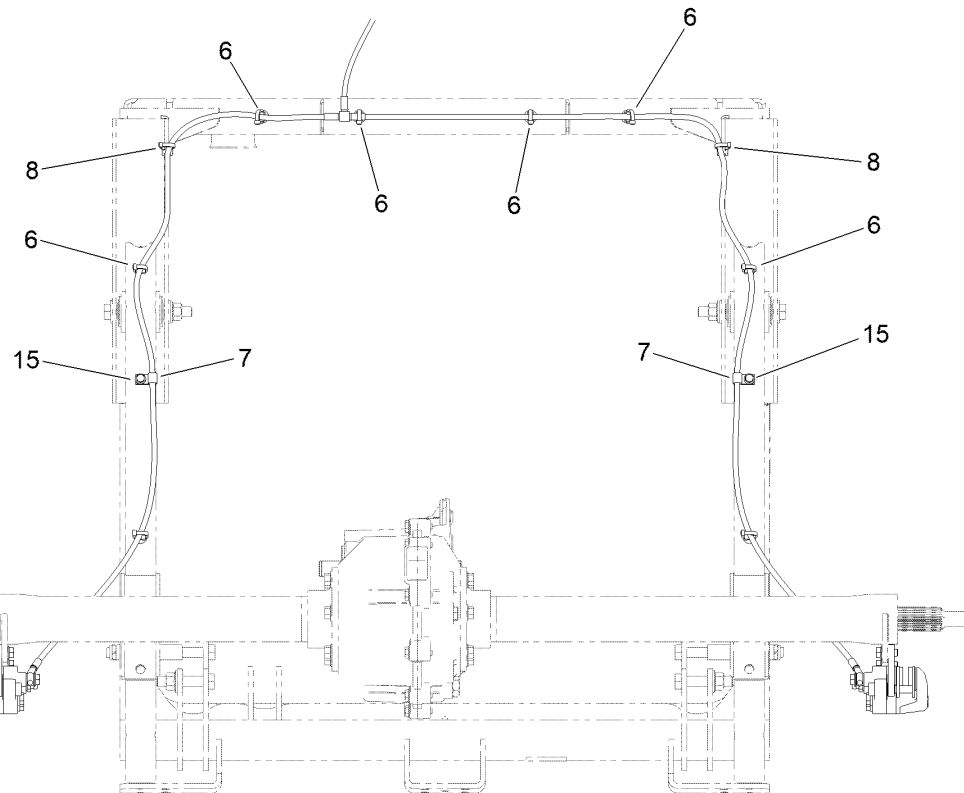
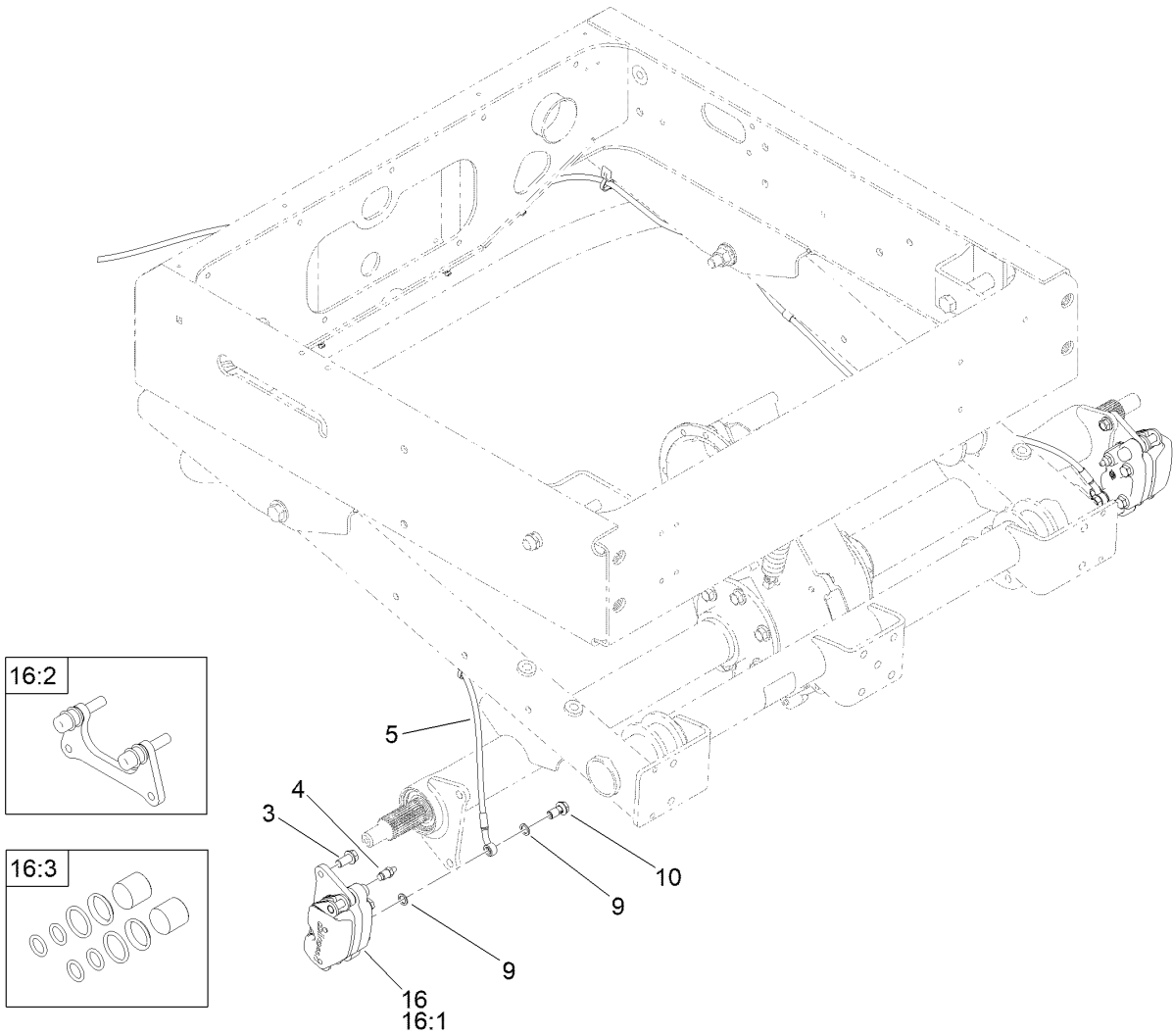

Rear Brake Assembly (continued)

<i>Ref.</i>	<i>Part Number</i>	<i>Qty.</i>	<i>Description</i>	<i>Ref.</i>	<i>Part Number</i>	<i>Qty.</i>	<i>Description</i>
3	144-5550	4	Screw-Spl	10	120-4875	2	Bolt-Flange, Banjo
4	119-9509	2	Screw-Bleed	15	32144-10	2	Screw-HWH
5	147-3897	1	Brake Line ASM, Rear	16	161-1890	2	Brake Caliper ASM
6	32180-030	8	Clip-Tie	16:1	140-2580	1	Brake Pad Service Kit (Front, Qty 4)
7	2412-89	2	Clamp-R	16:2	119-9511	1	Bracket Kit
8	32180-082	2	Clip-Edge W/Tie, Perpendicular	16:3	133-0614	1	Piston Kit
9	115-2341	4	Washer-Banjo				

Steering Assembly

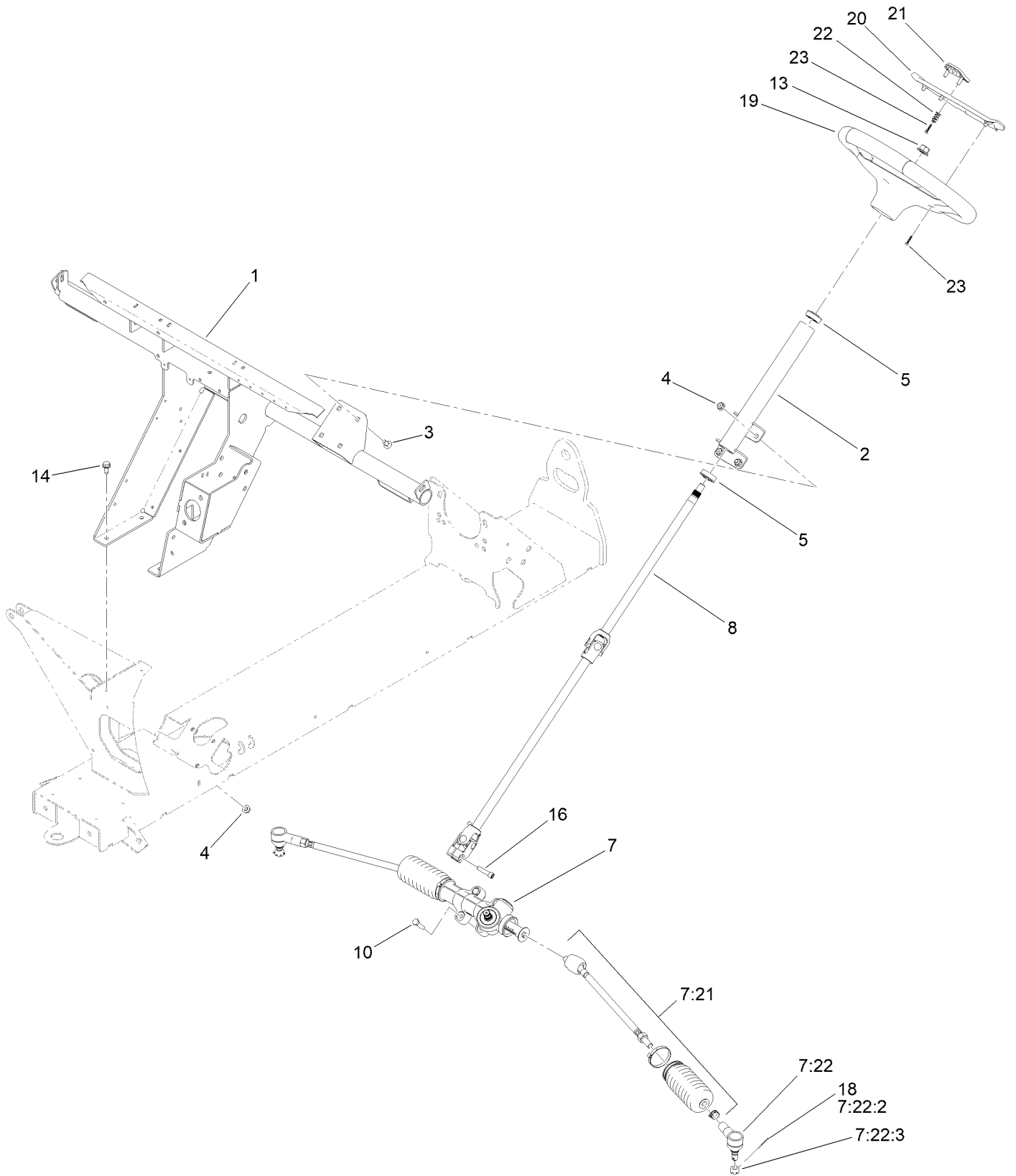

Steering Assembly (continued)

<i>Ref.</i>	<i>Part Number</i>	<i>Qty.</i>	<i>Description</i>	<i>Ref.</i>	<i>Part Number</i>	<i>Qty.</i>	<i>Description</i>
1	147-3840-03	1	Dash Support ASM [black]	10	322-6	4	Screw-HH
2	145-2065	1	Steering Column ASM, MDX	13	99-5107	1	Nut-Lock
3	3230-1	4	Bolt-CARR	14	32144-70	4	Screw-HWHTF
4	104-8300	8	Nut-HF, NI	16	145-7145	1	Screw-HSH,Lock
5	112-3262	2	Bearing	18	3272-42	2	Pin-Cotter
7	140-4560	1	Steering Rack ASM	19	144-5570	1	Steering Wheel ASM
7:21	140-4594	1	Kit-Tie Rod ASM, MDX	20	144-5567	1	Cover-Wheel, Steering
7:22	140-4592	1	Kit-Rod End ASM	21	144-5566	1	Clip-Wheel, Steering
7:22:2	3272-42	1	Pin-Cotter	22	144-5537	2	Spring-Compression
7:22:3	140-2493	1	Nut-Hex, Slotted	23	94-4496	5	Screw-PPH
8	145-2051	1	Steering Shaft ASM				

Accelerator and Brake Pedal Assembly

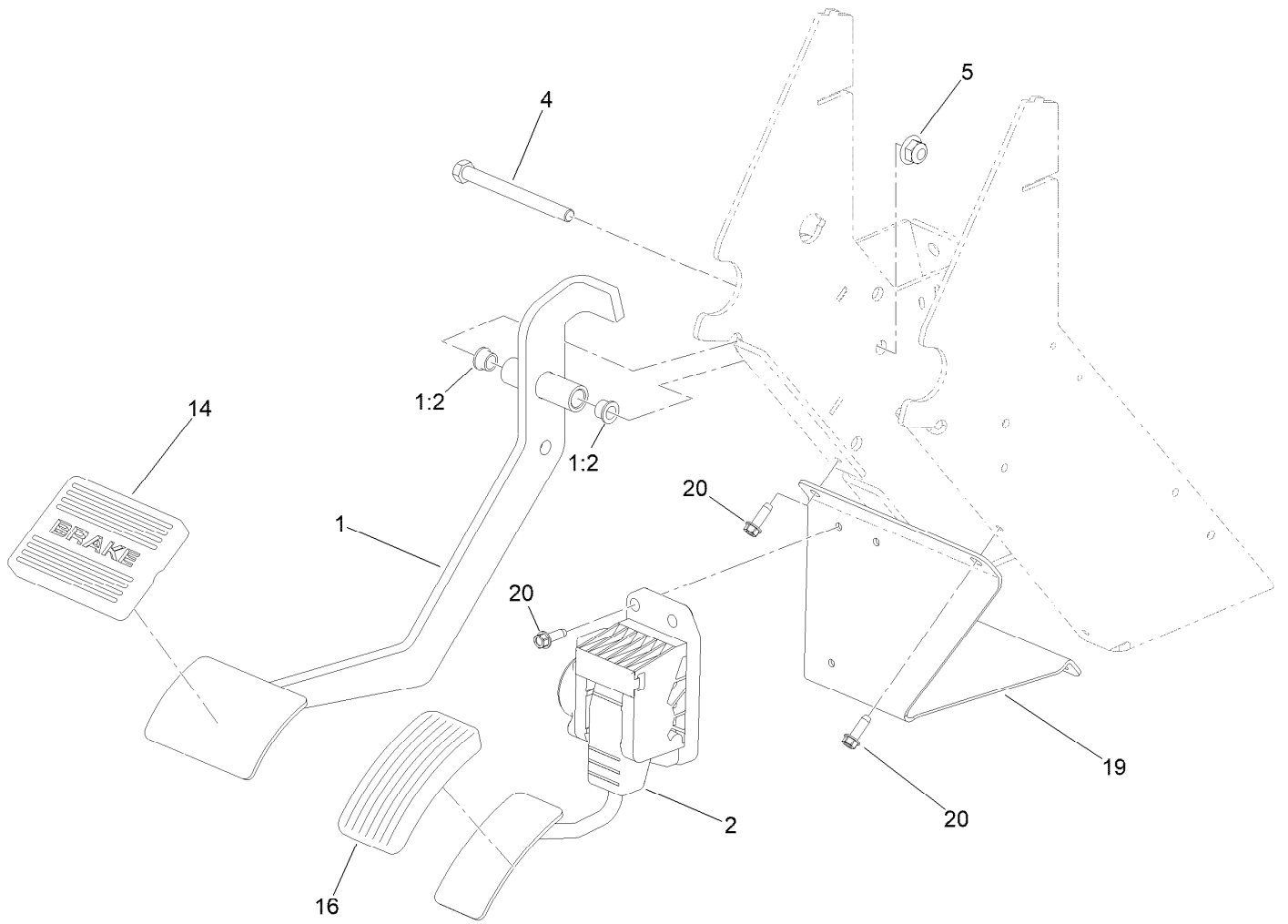

Accelerator and Brake Pedal Assembly (continued)

<i>Ref.</i>	<i>Part Number</i>	<i>Qty.</i>	<i>Description</i>	<i>Ref.</i>	<i>Part Number</i>	<i>Qty.</i>	<i>Description</i>
1	147-4078	1	Brake Pedal ASM	14	7-3900	1	Pad-Brake
1:2	256-116	2	Bushing-Flange	16	140-4572	1	Pedal Pad-Throttle
2	144-2740	1	Pedal ASM-Accelerator	19	147-3830-03	1	Bracket-Pedal, Accelerator
4	323-16	1	Screw-HH	20	49-2040	7	Screw-HWHTF
5	104-8301	1	Nut-HF, NI				

Hood and Fenders Assembly

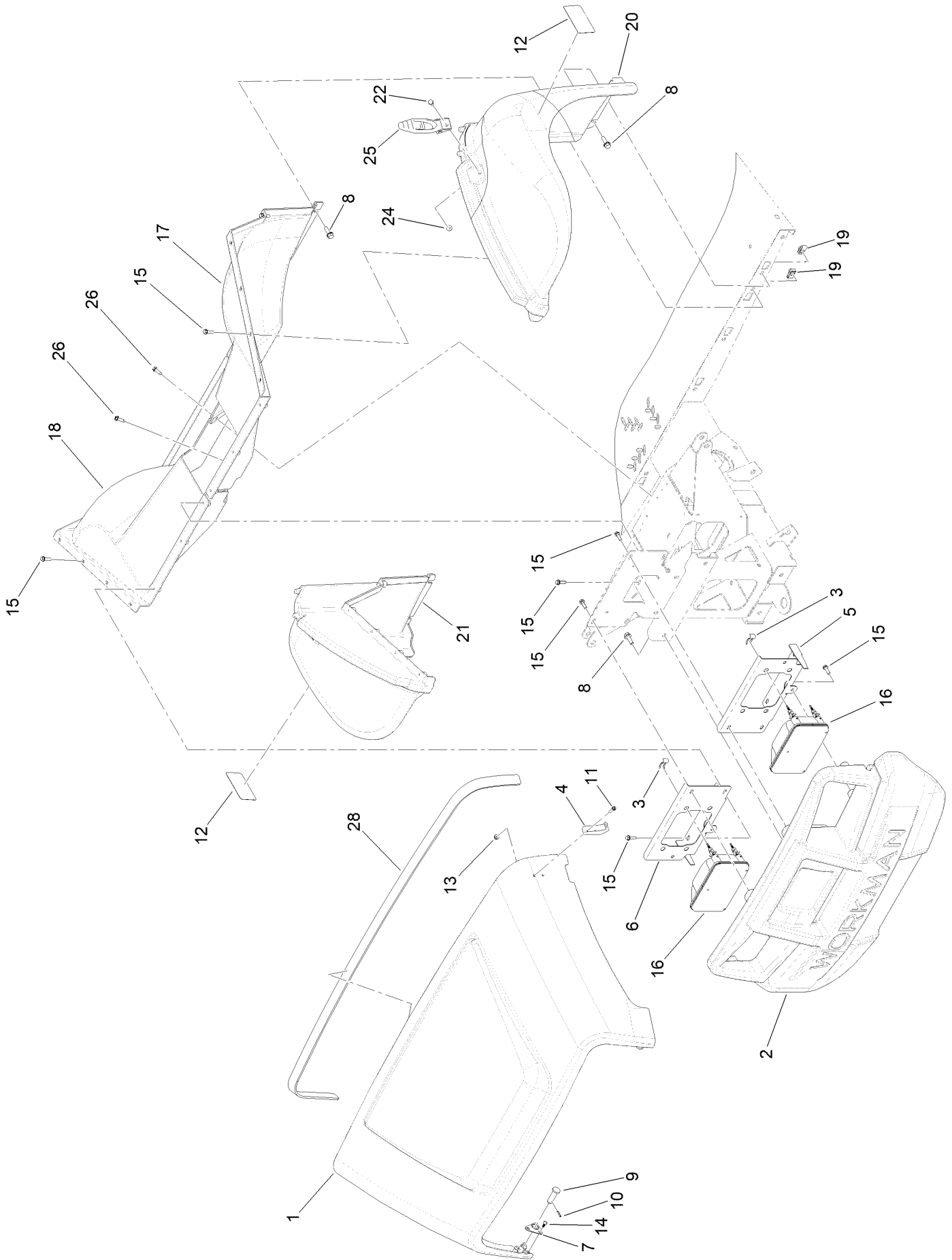

Hood and Fenders Assembly (continued)

<i>Ref.</i>	<i>Part Number</i>	<i>Qty.</i>	<i>Description</i>	<i>Ref.</i>	<i>Part Number</i>	<i>Qty.</i>	<i>Description</i>
1	136-6281	1	Hood	14	121-9605	6	Screw-HWH
2	132-8530	1	Bumper	15	46-8091	24	Screw-HWH
3	115-2408	6	Clip-Speed	16	138-9260	2	Headlight ASM
4	103-2897	2	Latch-Catch	17	132-6775	1	Fender-Inner, LH
5	140-4780-0P	1	Bracket-Headlight, LH	18	132-6776	1	Fender-Inner, RH
6	140-4781-0P	1	Bracket-Headlight, RH	19	112-3306	10	Nut
7	112-3308	2	Retainer-Pin	20	147-3947	1	Fender-Front, LH (MDX)
8	3234-29	12	Screw-HHF	21	147-3946	1	Fender-Front, RH (MDX)
9	117-5094	2	Pin-Clevis	22	321-39	2	Screw-HH
10	32121-50	2	Pin-Spring	24	104-7201	2	Nut-HF, NI
11	32105-13	4	Screw-HWH	25	115-2416	2	Latch-Rubber
12	147-3924	2	Decal-Fender, MDX, Lithium	26	49-2040	4	Screw-HWHTF
13	120-4578	4	Nut-HF	28	115-7635	1	Seal-Foam

Dash Assembly

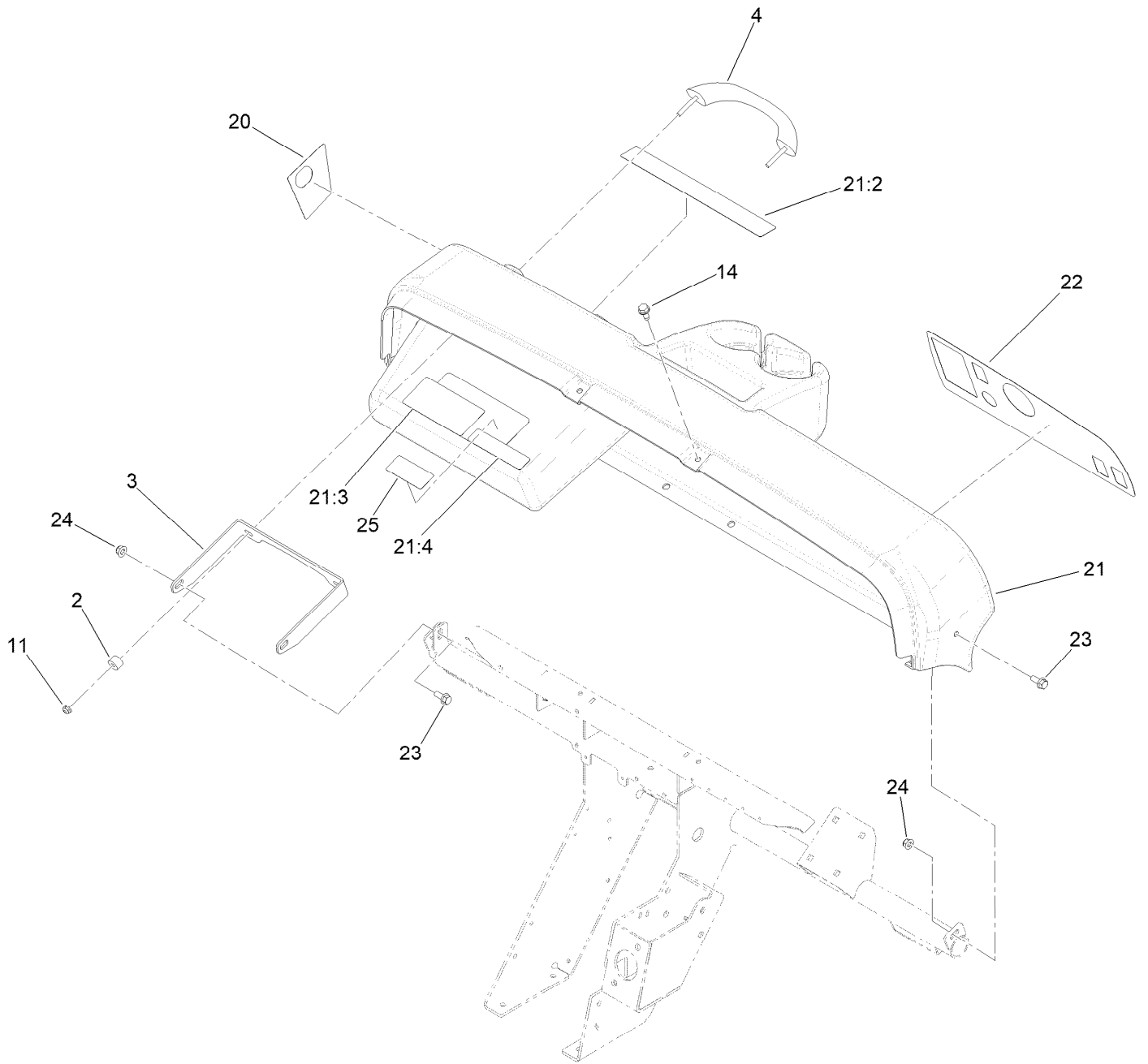

Dash Assembly (continued)

<i>Ref.</i>	<i>Part Number</i>	<i>Qty.</i>	<i>Description</i>	<i>Ref.</i>	<i>Part Number</i>	<i>Qty.</i>	<i>Description</i>
2	114-8301	2	Spacer	21:3	115-2412	1	Decal-No Storage
3	112-3391-0P	1	Bracket-Grip Handle	21:4	147-4085	1	Decal-Safety Voltage/Fuse Block
4	112-3320	1	Handle-Grip				
11	104-7201	2	Nut-HF, NI	22	147-3846	1	Decal-Control Panel, MDX-Li
14	32144-70	6	Screw-HWHTF				
20	147-8185	1	Decal-USB	23	110-5053	3	Screw-HHF
21	147-3811	1	Dash-MDX Lithium, Service	24	104-8300	3	Nut-HF, NI
21:2	147-4080	1	Decal-Safety MDX-Lithium	25	147-4084	1	Decal-Service, MDX Li+

Seatbase Assembly

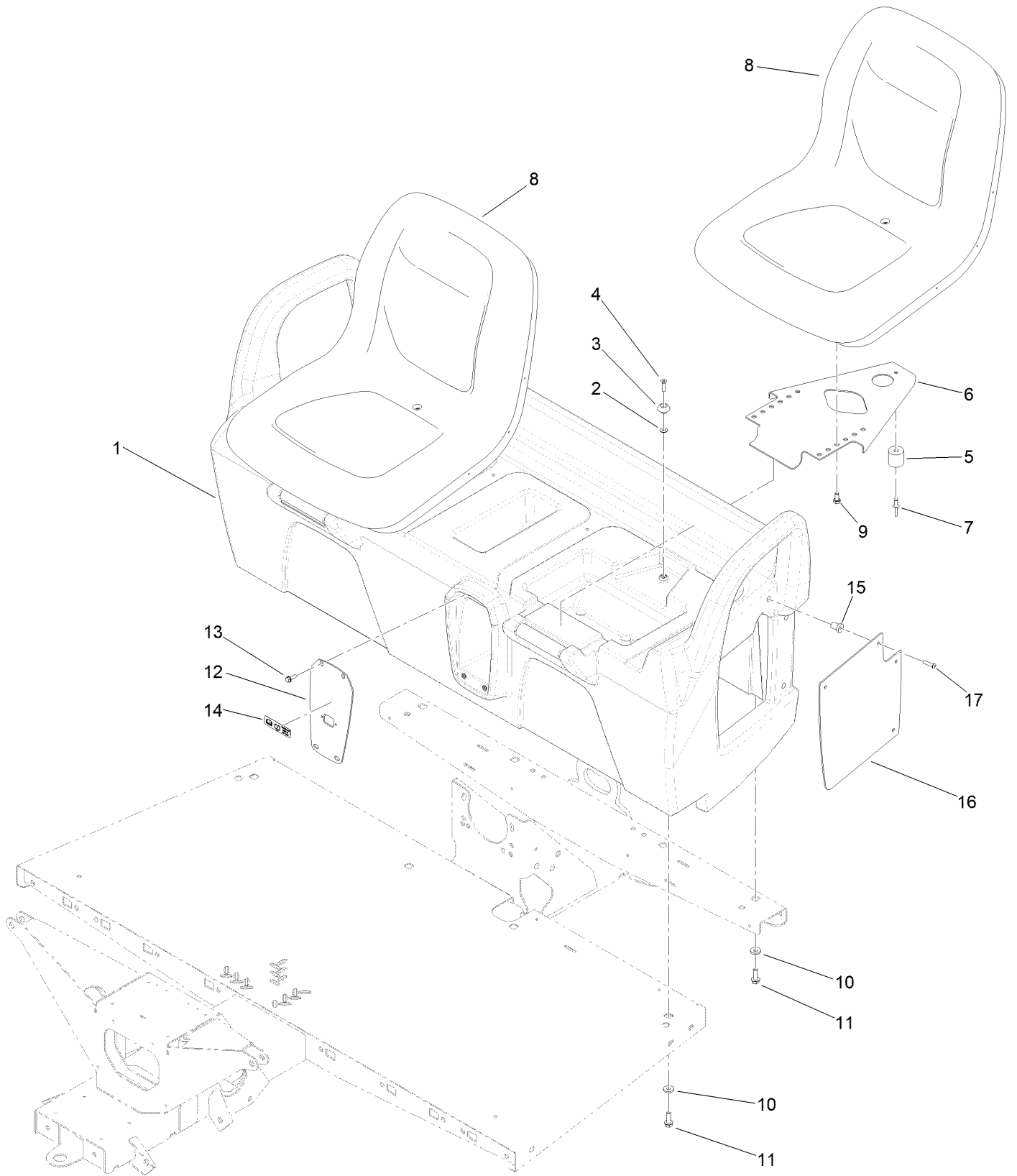

Seatbase Assembly (continued)

<i>Ref.</i>	<i>Part Number</i>	<i>Qty.</i>	<i>Description</i>	<i>Ref.</i>	<i>Part Number</i>	<i>Qty.</i>	<i>Description</i>
1	147-3831	1	Seat Base ASM	10	88-7200	8	Washer-Flat
2	3256-1	2	Washer-Flat	11	3234-17	8	Screw-HHF
3	99-7833	2	Post-Holding	12	145-7126-05	1	Plate-Receptacle
4	32108-5	2	Screw-FH	13	32105-15	4	Screw-HWH
5	99-7830	2	Receptical-Rubber	14	140-4590	1	Decal-Charger Input Lithium
6	99-7829	2	Bracket-Seat	15	32117-1	4	Nut-Insert
7	3290-412	2	Rivet-Blind	16	145-7127-05	1	Panel-Side
8	133-0577	2	Seat ASM	17	3274-65	4	Screw-HSBH
9	33114-016	8	Screw-HH				

Cargo Bed Assembly

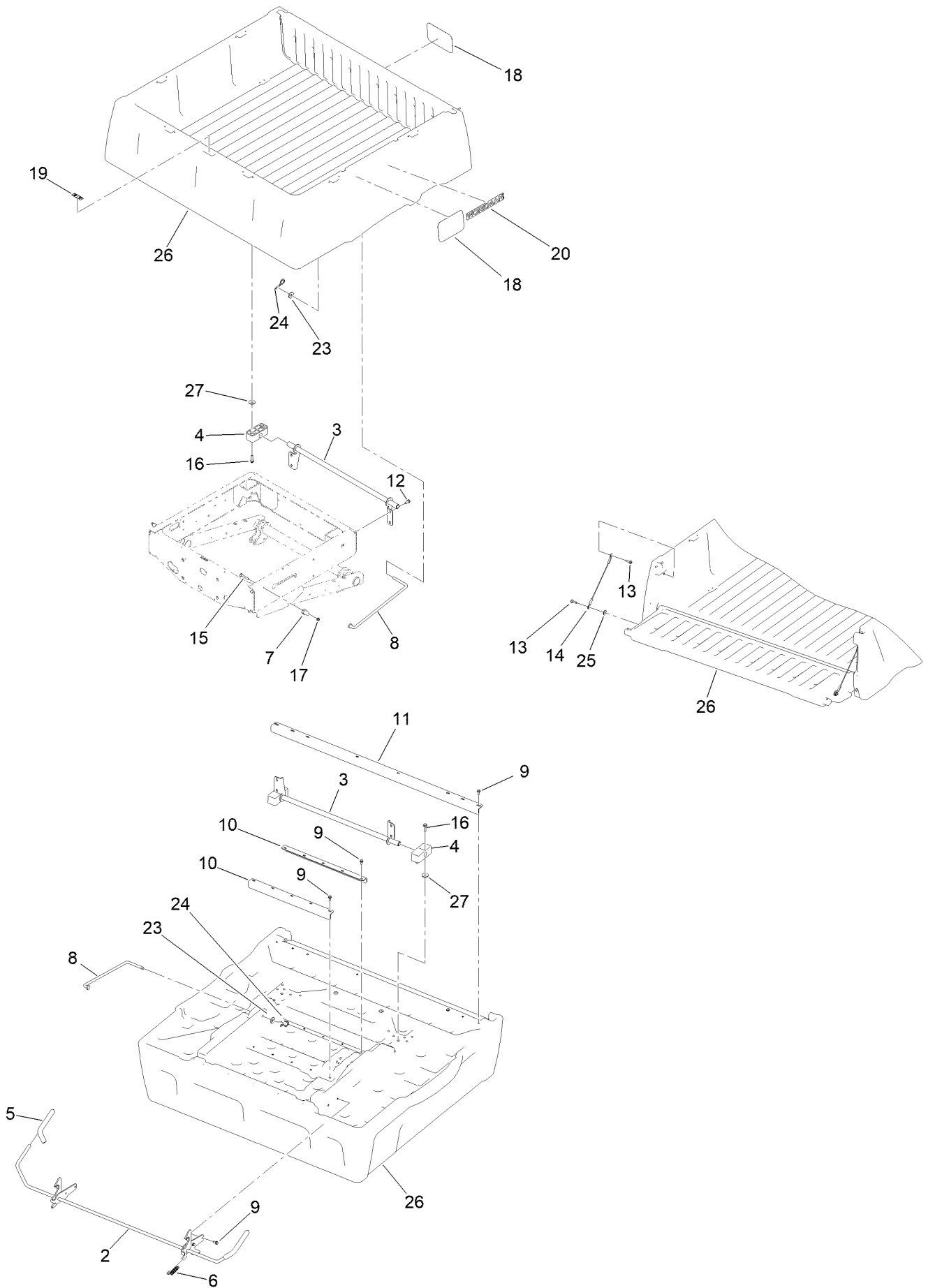

Cargo Bed Assembly (continued)

<i>Ref.</i>	<i>Part Number</i>	<i>Qty.</i>	<i>Description</i>	<i>Ref.</i>	<i>Part Number</i>	<i>Qty.</i>	<i>Description</i>
2	121-6344	1	Latch	15	3230-7	2	Bolt-CARR
3	133-0625-03	1	Bracket-Pivot	16	3234-18	4	Screw-HHF
4	121-6342	2	Bushing-Pivot	17	104-8300	2	Nut-HF, NI
5	119-9627	2	Grip-Handle	18	104-7213	3	Decal
6	5-7290	2	Spring-Tension	19	115-7739	1	Decal-No Riders
7	144-2191	2	Pin-Latch	20	140-4835	2	Decal-Workman, Gray
8	121-6316	1	Rod-Prop	23	110-6147	1	Washer-Flat
9	3234-5	20	Screw-HHF	24	107-3155	1	Hairpin
10	121-6314-0P	2	Brace-Middle, Bed	25	115-7109	2	Washer-Flat
11	121-6315-0P	1	Brace-Rear, Bed	26	147-4026	1	Cargo Bed/Tailgate ASM [svc]
12	126-1696	4	Screw-HWHTF	27	87-5330	4	Washer
13	119-2267	4	Screw-Shoulder, BHTF				
14	121-6343	2	Lanyard-Tailgate				

Cargo Bed Service Assembly No. 147-4026

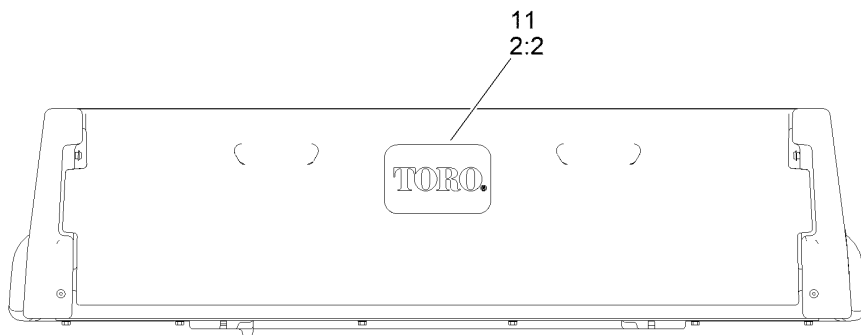
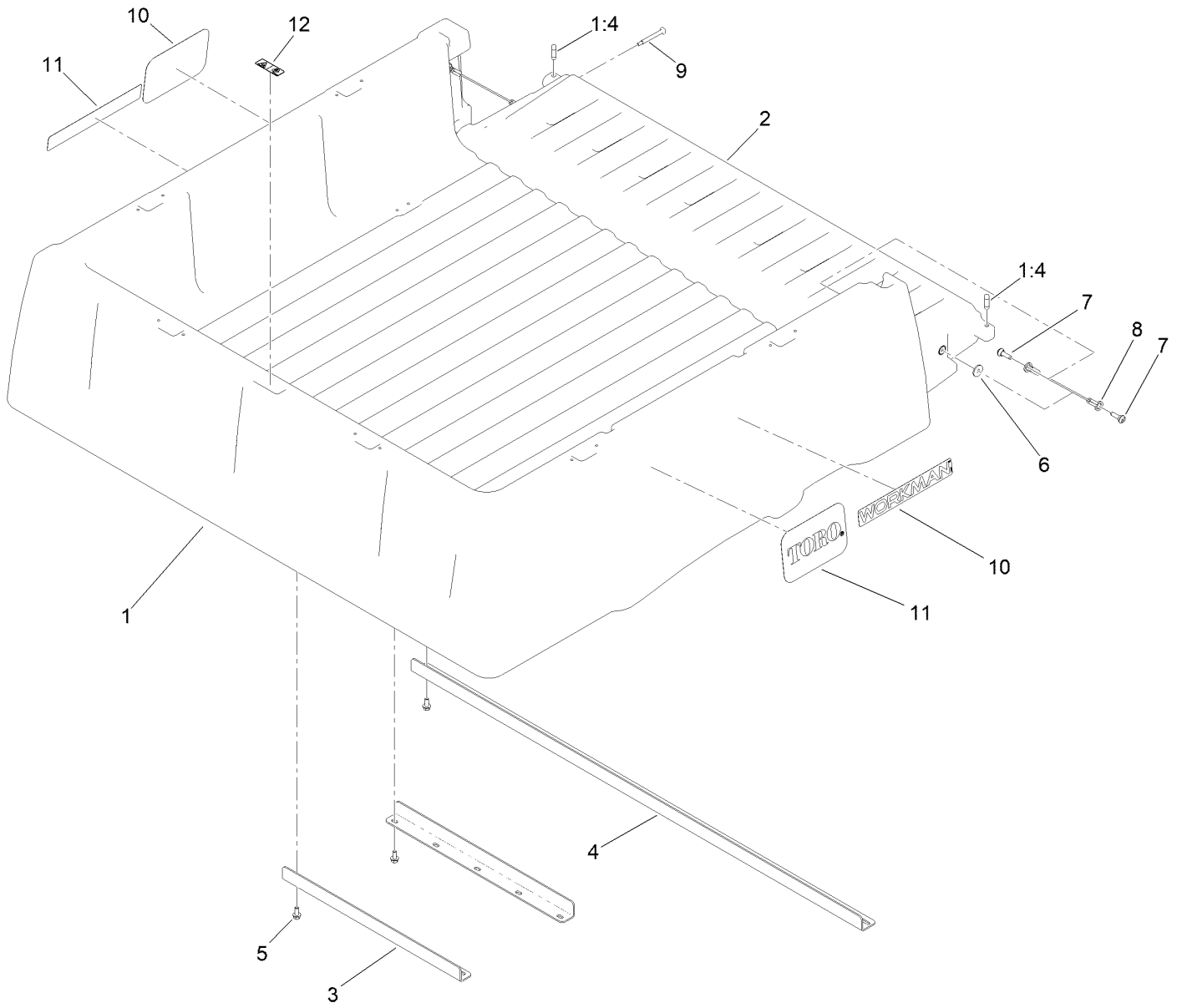

Cargo Bed Service Assembly No. 147-4026 (continued)

<i>Ref.</i>	<i>Part Number</i>	<i>Qty.</i>	<i>Description</i>	<i>Ref.</i>	<i>Part Number</i>	<i>Qty.</i>	<i>Description</i>
1		1	Cargo Bed And Tailgate ASM ●	6	115-7109	2	Washer-Flat
1:4	133-7146	2	Plug-Tailgate, Anti-Rattle	7	119-2267	4	Screw-Shoulder, BHTF
2	133-0561	1	Tailgate ASM W/Decals	8	121-6343	2	Lanyard-Tailgate
2:2	104-7213	1	Decal	9	127-7383	2	Screw-Shoulder, Bh (Torx)
3	121-6314-0P	2	Brace-Middle, Bed	10	140-4835	2	Decal-Workman, Gray
4	121-6315-0P	1	Brace-Rear, Bed	11	104-7213	3	Decal
5	3234-5	16	Screw-HHF	12	115-7739	1	Decal-No Riders

● Not serviced separately

Battery and Transaxle Assembly

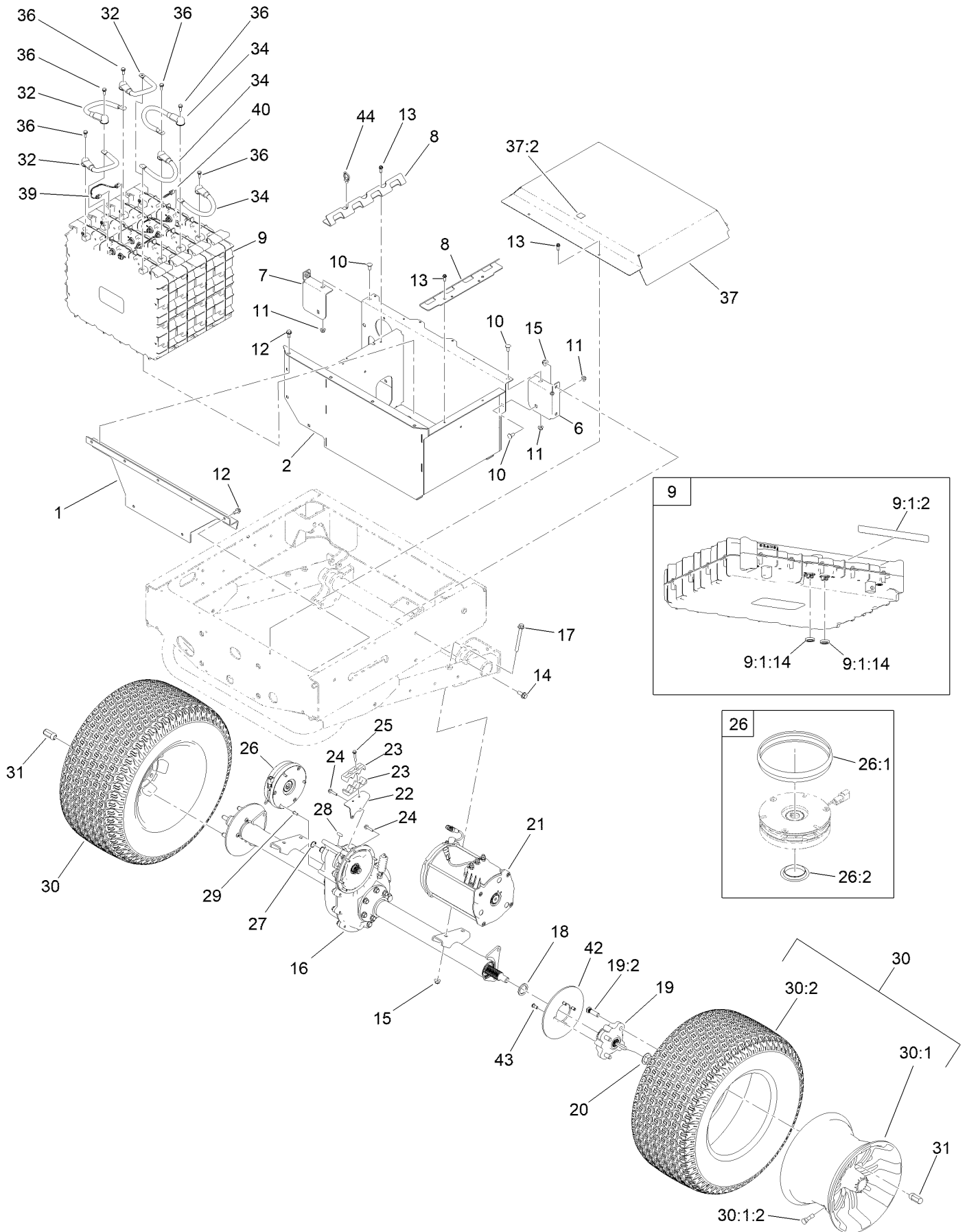

Battery and Transaxle Assembly (continued)

<i>Ref.</i>	<i>Part Number</i>	<i>Qty.</i>	<i>Description</i>	<i>Ref.</i>	<i>Part Number</i>	<i>Qty.</i>	<i>Description</i>
1	147-3853-0P	1	Bracket-Support, Front	25	94-2691	2	Screw-HWH Taptite
2	147-3979-0P	1	Box-Battery [primed]	26	145-7061	1	Brake-Electric
6	147-3852-0P	1	Bracket-Support, Left	26:1	145-7184	1	Dust Cover
7	147-3854-0P	1	Bracket-Support, Right	26:2	145-7186	1	End Cap
8	147-3806-0P	2	Hold Down, Battery	27	32120-15	1	Ring-Snap, EXT
9	145-5320	4	Battery ASM	28	145-7163	1	Key-Square
9:1:2	145-5338	1	Decal-Warning, Battery	29	145-7164	3	Screw-HSBH
9:1:14	32180-466	2	Nut-Mounting, Jwvf Panel Lock	30	147-3970	2	Wheel And Tire ASM
10	3230-23	3	Bolt-CARR	30:1	147-3967	1	Wheel-Aluminum
11	104-8300	3	Nut-HF, NI	30:1:2	232-27	1	Stem-Valve
12	32144-70	11	Screw-HWHTF	30:2	116-8296	1	Tire-Drive
13	49-2040	8	Screw-HWHTF	31	139-3603	8	Nut-Lug
14	3234-42	4	Screw-HHF	32	145-7182	3	Cable-Battery,Rd ASM
15	104-8301	8	Nut-HF, NI	34	145-7183	3	Cable-Battery,Bk ASM
16	147-3858	1	Transaxle ASM	36	145-5783	6	Screw-Sems
17	116-4701	4	Screw-HHF	37	147-4079	1	Battery Cover ASM
18	144-2444	2	Spacer-Hardened	37:2	145-7345	1	Decal-Voltage, High
19	145-7151	2	Rear Hub ASM	39	140-9565	3	Harness-Wire, Data Interface
19:2	10-6830	4	Stud-Type, Drive	40	122-2323	1	Harness-Wire, Can Terminator
20	32128-53	2	Nut-HF	42	139-4474	2	Rotor-Brake
21	137-6936	1	Motor-AC	43	121-9671	8	Screw-HSBH
22	147-3859-0P	1	Bracket-Clamp, Cable	44	32180-030	2	Clip-Tie
23	145-7166	2	Clamp-Cable				
24	33103-030	6	Screw-HHF				

Transaxle Assembly No. 147-3858

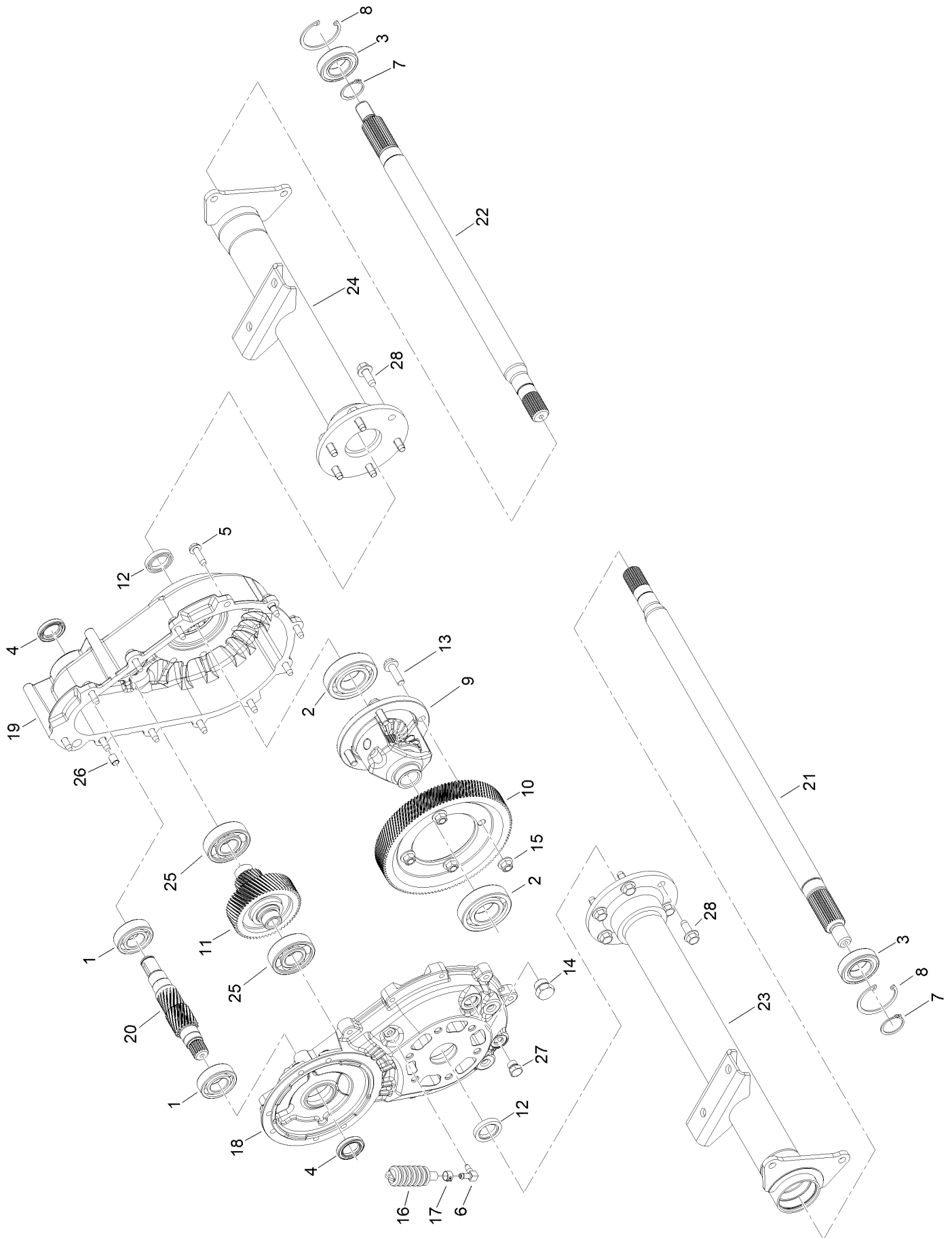

Transaxle Assembly No. 147-3858 (continued)

<i>Ref.</i>	<i>Part Number</i>	<i>Qty.</i>	<i>Description</i>	<i>Ref.</i>	<i>Part Number</i>	<i>Qty.</i>	<i>Description</i>
1	145-7286	2	Bearing, Ball, Single Row, 6205	13	133-2462	4	Bolt-HHF
2	145-7287	2	Bearing, Ball, Single Row, 6207	14	145-7319	1	Plug, Hex Head, 3/4-16 Strt Thr, O-Ring
3	147-4094	2	Bearing, Ball, Single Row, 6006-2Rs, Sealed	15	133-2463	4	Nut-Lock
4	145-7289	2	Seal, Oil, .945 Shaft, 1.499 Bore	16	145-7294	1	Vent, Bellows
5	147-4095	12	Screw, Hex Head, 5/16-18, Thread Forming	17	145-7295	1	Clamp, Hose
6	147-4096	1	Tube, Vent	18	161-1800	1	Housing, Motor Side
7	147-4097	2	Ring, Retaining, External, 30MM Shaft	19	161-1801	1	Housing, Cover, E-Brake
8	147-4098	2	Ring, Retaining, Internal, 55MM Bore	20	145-7298	1	Shaft, Input, 18T
9	147-4099	1	Assembly, Differential Case, Heavy Duty	21	161-1802	1	Shaft, Axle
10	145-7291	1	Gear, Helical, Output, Finish, 116T	22	161-1803	1	Shaft, Axle
11	145-7292	1	Assembly, Shaft And Gear, Intermediate	23	161-1804	1	Tube Assembly, LH
12	145-7293	2	Seal, Oil, 25 MM Shaft, 1.499 Bore	24	161-1805	1	Tube Assembly, RH
				25	145-7299	2	Bearing, Ball, Single Row, 6305
				26	145-7301	2	Bushing, Dowel, .313 X .500
				27	145-7302	1	Drain Plug, Magnetic, O-Ring, 1/2-20
				28	161-1806	12	Screw, Flange Head, 3/8-16 X 1.00

Electric Motor Assembly No. 137-6936

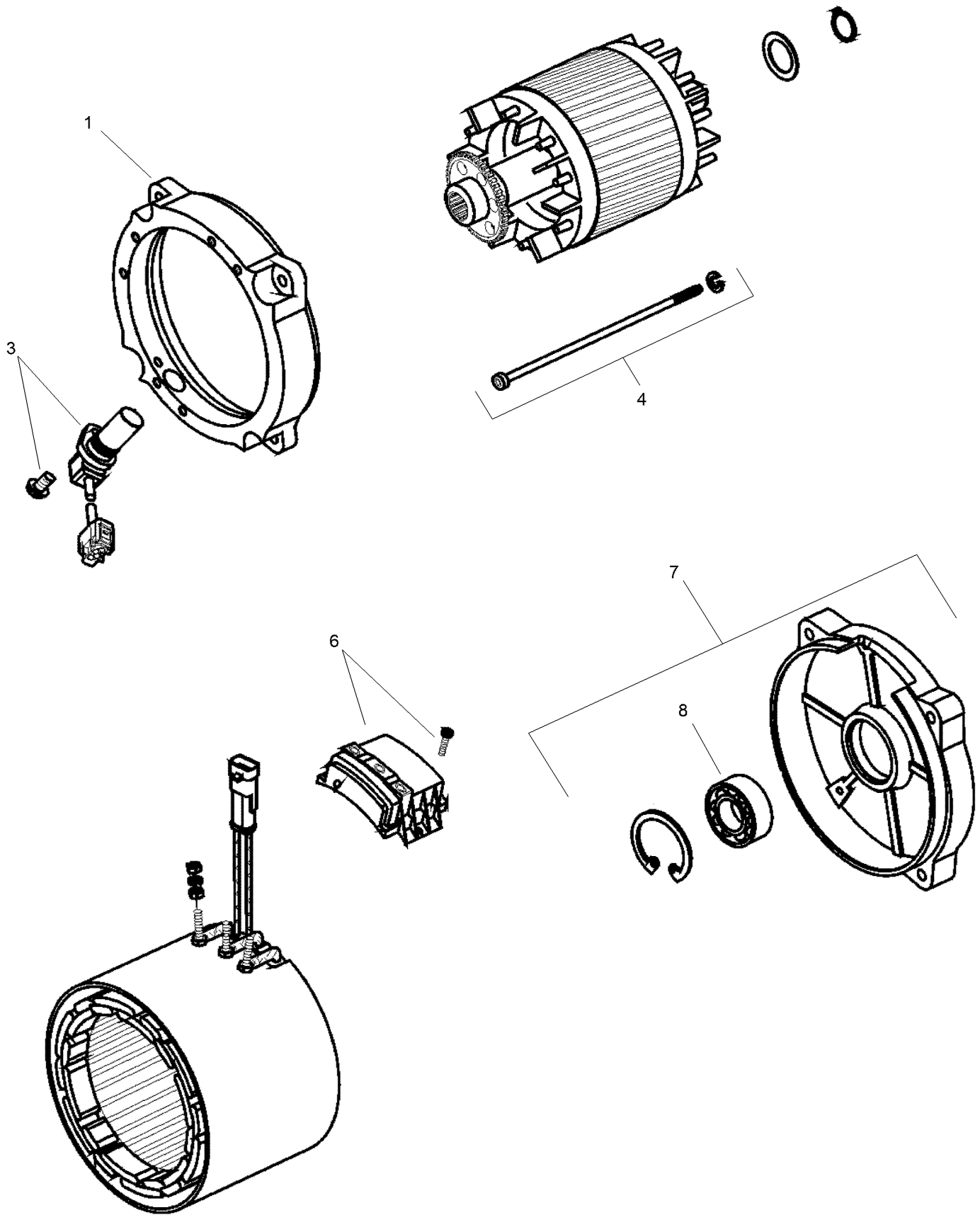

Electric Motor Assembly No. 137-6936 (continued)

<i>Ref.</i>	<i>Part Number</i>	<i>Qty.</i>	<i>Description</i>
1	132-4924	1	Bracket-End, Drive
3	132-4925	1	Sensor
4	132-4926	1	Screw

<i>Ref.</i>	<i>Part Number</i>	<i>Qty.</i>	<i>Description</i>
6	132-4927	1	Plate-Connection
7	132-4928	1	Bracket-End, Rear
8	132-4929	1	Bearing

Electrical Assembly

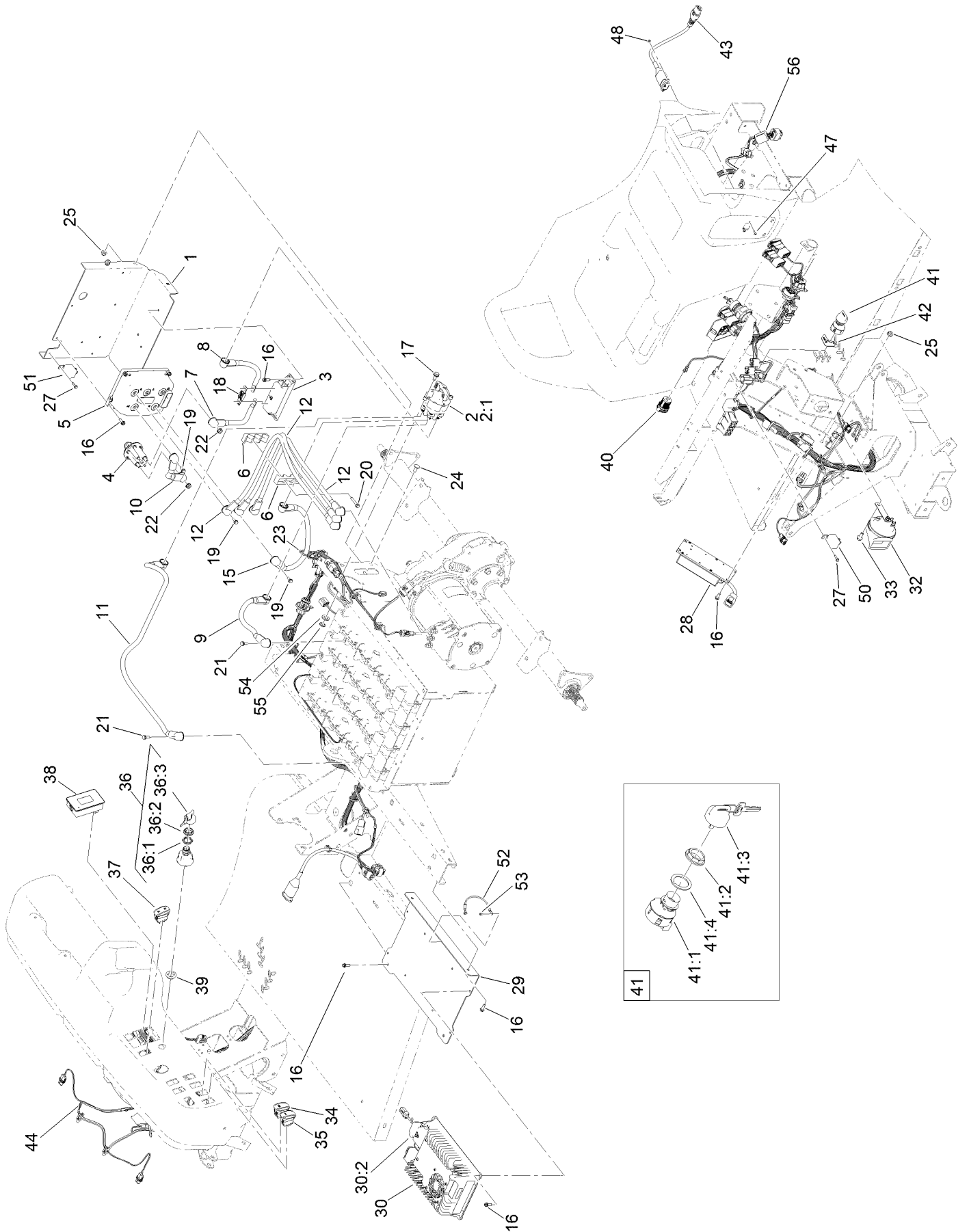

Electrical Assembly (continued)

<i>Ref.</i>	<i>Part Number</i>	<i>Qty.</i>	<i>Description</i>	<i>Ref.</i>	<i>Part Number</i>	<i>Qty.</i>	<i>Description</i>
1	147-3861-0P	1	Panel-Electrical, Box	35	144-2415	1	Switch-Rocker, (On)-None-Off
2	122-0603	1	Switch-Disconnect	36	122-2513	1	Switch-Ignition, Suns
2:1	33006-00	1	Nut-HF	36:1	121-5160	1	Nut-Hex ●
3	145-4958	1	Holder-Fuse	36:2	122-2704	1	Nut-Face, M22 (Plastic)
4	122-2616	1	Contactora-Powerseal	36:3	121-5162	1	Set-Key, Ignition
5	145-5050	1	Inv/Ctrlr-48V,185Arms	37	122-2654	1	Switch-Rocker, On-None-On
6	145-7166	2	Clamp-Cable	38	122-2152	1	Controller, Tdm-1601
7	147-3873	1	Cable-Battery, Rd ASM	39	145-7110	1	Adapter-Switch, Key
8	147-3874	1	Cable-Battery, Rd ASM	40	131-8388	1	Socket-USB
9	145-7277	1	Cable-Battery,Rd ASM	41	110-2580	1	Switch-Key, Supervisor
10	145-7173	1	Cable-Battery,Rd ASM	41:1		1	Switch-Key ■
11	147-3982	1	Cable-Battery,Bk ASM	41:2	108-8660	1	Nut-Mounting
12	145-7279	3	Cable-Battery,Rd ASM	41:3	110-5221	1	Set-Key, Supervisor
15	145-7179	1	Cable-Battery,Bk ASM	41:4	108-8659	1	Washer-Backup
16	49-2040	18	Screw-HWHTF	42	140-0924	1	Decal-Mode
17	32144-70	2	Screw-HWHTF	43	145-7147	1	Cordset W/Filter
18	122-2630	1	Fuse-250A	44	122-2478	1	Harness-Wire, MDX-Li
19	145-5782	5	Screw-Sems	47	3249-3	2	Screw-PRH
20	94-2691	2	Screw-HWH Taptite	48	3296-9	2	Nut-Hex
21	145-5783	2	Screw-Sems	50	122-2400	1	Relay, 12V Coil, 50A At 48V
22	107-0380	2	Nut-HF	51	122-2401	1	Relay, 48V Coil, 50A At 48V
23	32180-030	2	Clip-Tie	52	122-2792	1	Harness-Wire, Charger Bonding
24	3230-23	6	Bolt-CARR	53	125-0519	2	Screw-Self Tapping
25	104-8300	7	Nut-HF, NI	54	147-3238	4	Washer-Flat
27	100-4351	4	Screw-HWH	55	HDW14457	4	Split Lock Washer,1/2,ST/ST,18-8
28	144-6975	1	Converter DC-DC	56	147-8183	2	Ferrite, Snap-On
29	147-3815-03	1	Bracket-Charger				
30	145-1177	1	Charger-Onboard				
30:2	147-3234	1	Kit-Service, DC Harness				
32	107-0358	1	Horn				
33	110-5053	1	Screw-HHF				
34	144-2405	1	Switch-Rocker, On-None-On				

● Not illustrated

■ Not serviced separately

Wire Harness Assembly No. 122-2478

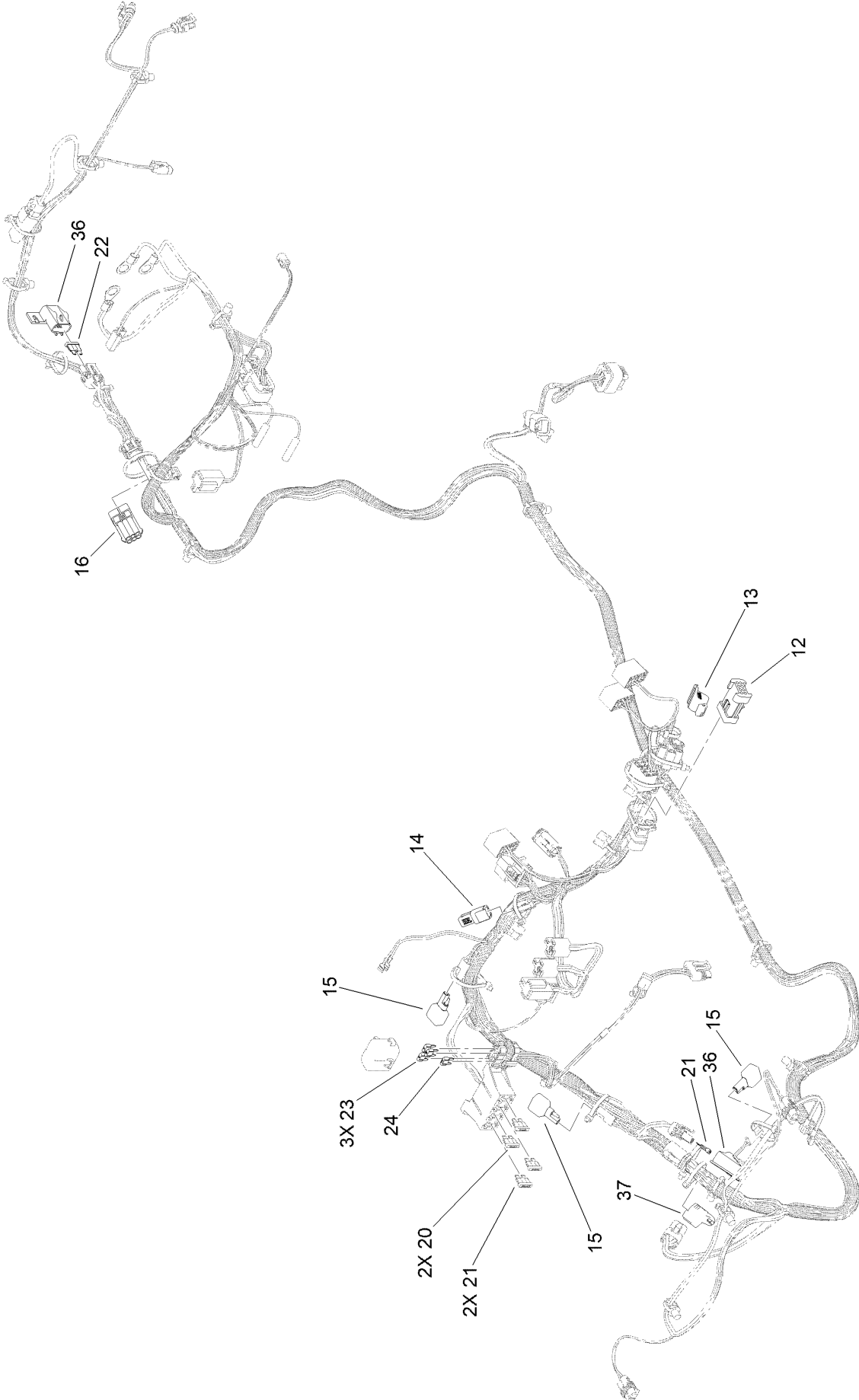

Wire Harness Assembly No. 122-2478 (continued)

<i>Ref.</i>	<i>Part Number</i>	<i>Qty.</i>	<i>Description</i>	<i>Ref.</i>	<i>Part Number</i>	<i>Qty.</i>	<i>Description</i>
12	32160-036	1	Connector-Mp150, 8M	21	117-4726	3	Fuse-Blade, 20A
13	32180-089	1	Cap-Plug, 3 Way	22	117-4728	1	Fuse-Blade, 30A
14	32180-282	1	Resistor-120 Ohm	23	121-8864	3	Fuse-Mini Blade, 5 Amp
15	100-4918	3	Diode	24	121-8865	1	Fuse-Mini Blade, 7.5 Amp
16	32160-035	1	Connector	36	32180-567	2	Cover-Aptiv, Modified
20	117-4724	2	Fuse-Blade, 10A	37	32180-156	1	Cap-Plug, 6 Way

Attachments and Accessories

For 08303 Workman MDX Lithium Utility Vehicle

Product Name	Model/Part
Canopy Kit	07324
Folding Windshield Kit	07326
Roll-Over Protection System	07276
Side Mirrors Kit	145-7140
Side Mirror Kit	119-9546
Electric Lift Kit, MDX LI	08389
Receiver Hitch Kit	07278
Hitch ASM	131-3462
Stake Pocket Adapter Kit, 2011 and After Workman MD Series Utility Vehicle	119-9604
Tie-Down Kit, 2011 and After Workman MD Series Utility Vehicle	119-9605
Front Spring Kit, 2016 and After MDX or MDX-D Series Utility Vehicle	133-0630
Brush Guard Kit	07145
Front Hitch Kit, Workman GTX Series Utility Vehicles with Brush Guard	07146
Trash Can Mounting Kit	07028
Brake and Signal LED Light Kit, Workman MD Series Utility Vehicle	145-2082
Reverse Alarm Kit	131-8549
Universal Wireless Hourmeter Kit	144-2436
Wireless Hour Meter Finish Kit	138-5698
External Antenna Kit, Wireless Hourmeter System	115-9524
Base Station Kit, Wireless Hourmeter System	115-9542
Repeater Kit, Wireless Hourmeter System	115-9543
Spanner Wrench	132-5069
Service Hood ASM	133-7209
Small Seat Cover	131-6690
Power Point Kit	131-8550

Notes:



Count on it.