



Count on it.

Parts Catalog

**STX-26
Stump Grinder**

Model No. 23208—Serial No. 414500000 and Up



Ordering Replacement Parts

To order replacement parts, please supply the part number, the quantity, and the description of each part desired.

Understanding Reference Numbers

Each identified part in an illustration has a reference number. The reference number for a part also appears in the parts list, along with other information about the part.

This catalog uses two special reference number formats, one to indicate parts in a service assembly and another to indicate the quantity of a given part in an illustration.

Service Assembly Reference Numbers

Parts in service assemblies have reference numbers in the form a:b. The a represents the reference number of the entire service assembly and the b represents a sequential number unique to each part within the service assembly.

For example, a wheel assembly might be identified by reference number 6, the tire by 6:1, the valve by 6:2, and the wheel by 6:3. When you order the assembly identified by reference number 6, you receive all parts identified by reference numbers 6:1, 6:2, and 6:3. However, you may also order any part individually. Reference numbers of this type appear in illustration and in parts lists.

Reference Numbers Indicating Quantity

In an illustration, if a reference number indicates more than one part, the reference number has the form nX y. The n represents the quantity of the part, the X is the multiplication symbol, and the y represents the reference number.

For example, in an illustration, the reference number 2X 37 means that two of the parts identified by reference number 37 are indicated.

Contents

Frame Assembly.....	4
Track and Drive Assembly.....	6
Hydraulic Pump Assembly No. 117-6409.....	8
Hydraulic Pump Assembly No. 117-6410.....	9
Hydraulic Motor Assembly No. 119-4557.....	10
Engine Assembly.....	12
Hydraulic Gear Pump Assembly No. 117-6444.....	14
Control Assembly.....	16
Frame and Cutter Wheel Assembly.....	18
Hydraulic Cylinder Assembly No. 117-6441.....	20
Hydraulic Motor Assembly No. 127-9603.....	21
Hydraulic Cylinder Assembly No. 121-1955.....	22
Tower and Fuel Tank Assembly.....	24
Control Valve Assembly.....	26
Control Valve Assembly No. 119-4585.....	27
Cutter Wheel Valve Assembly No. 119-4586.....	28
Two-Button Handle Grip Assembly No. 119-4587.....	29
Oil Cooler Assembly.....	30
Hydraulic Hose Routing Assembly.....	32
Battery and Electrical Assembly.....	34
Attachments and Accessories.....	36

Frame Assembly

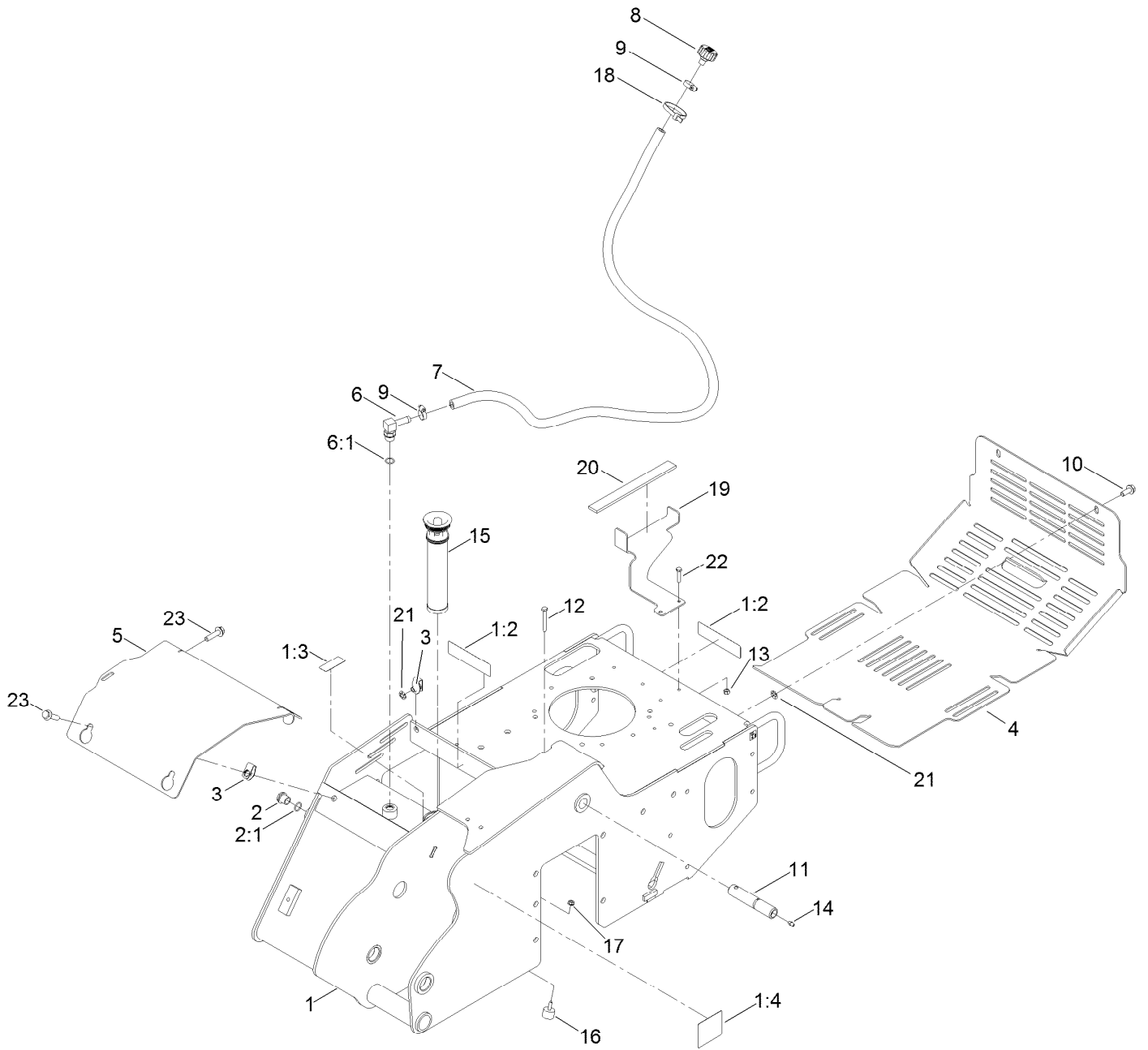

Frame Assembly (continued)

<i>Ref.</i>	<i>Part Number</i>	<i>Qty.</i>	<i>Description</i>	<i>Ref.</i>	<i>Part Number</i>	<i>Qty.</i>	<i>Description</i>
1	127-9602	1	Main Frame ASM	10	108-1531	2	Screw-HHF
1:2	100-4650	1	Decal-Warning	11	120-7352	1	Pin-Pivot
1:3	93-7814	2	Decal-Danger	12	321-18	1	Screw-HH
1:4	93-6686	1	Decal-Oil, HYD	13	3296-42	3	Nut-Lock, NI
2	114-3075	1	Sight Glass ASM	14	302-5	1	Fitting-Grease
2:1	237-79	1	O-Ring	15	114-3039	1	Filter-Tank, In
3	140-1146	5	Nut-Clip, U	16	1-523420	1	Bumper
4	119-5106-01	1	Cover-Rear	17	32128-33	1	Nut-HF
5	119-4566-03	1	Plate-Cover, Front	18	3334-945	1	Tie-Cable
6	354-120	1	Fitting-Elbow, 90	19	119-5091-01	1	Bracket-Tank
6:1	237-79	1	O-Ring	20	117-6417	1	Pad-Foam
7	114-3042	1	Hose-Breather	21	140-1144	5	Nut-Push
8	68-6150	1	Breather	22	321-8	2	Screw-HH
9	2412-36	2	Clamp-Hose	23	33105-040	3	Screw-HHF

Track and Drive Assembly

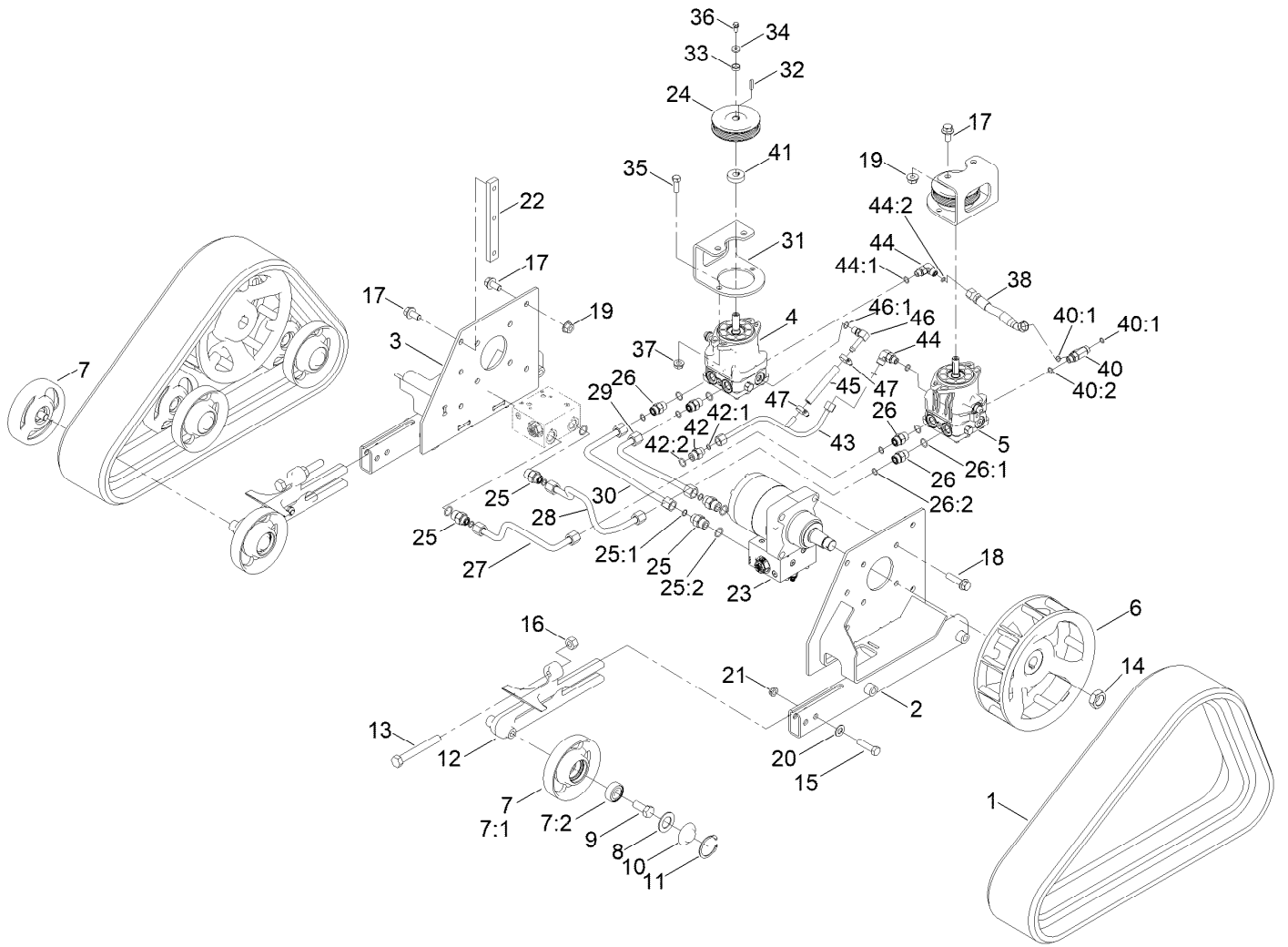

Track and Drive Assembly (continued)

<i>Ref.</i>	<i>Part Number</i>	<i>Qty.</i>	<i>Description</i>	<i>Ref.</i>	<i>Part Number</i>	<i>Qty.</i>	<i>Description</i>
1	112-4816	2	Track-Rubber	26:1	237-30	1	O-Ring
2	114-2992-03	1	Frame-Track, LH	26:2	237-79	1	O-Ring
3	114-2993-03	1	Frame-Track, RH	27	119-4581	1	Tube-HYD
4	117-6409	1	RH HYD Pump ASM	28	119-4582	1	Tube-HYD
5	117-6410	1	LH HYD Pump ASM	29	119-4583	1	Tube-HYD
6	117-6426-03	2	Wheel-Drive	30	119-4584	1	Tube-HYD
7	138-3139	12	Tensioner Wheel ASM	31	115-1289-03	2	Bracket-Mount, Pump
7:1	138-7118	1	Wheel-Track	32	80-6090	2	Key-Pump
7:2	120-5378	1	Bearing-Ball	33	108-4211	2	Bushing
8	106-7585	12	Gasket-Bogie	34	73-3580	2	Washer
9	327-4	12	Screw-HH	35	324-5	4	Screw-HH
10	106-7557	12	Cap-Wheel, Bearing	36	33103-016	2	Screw-HHF
11	106-7595	12	Ring-Snap, Internal	37	32128-42	4	Nut-HF
12	114-3077-03	2	Tensioner-Track	38	115-1297	1	Hose-HYD
13	112-4874	2	Screw-HH, TAP	40	340-86	1	Fitting-Tee
14	106-8159	2	Nut-Lock	40:1	237-22	2	O-Ring
15	325-8	4	Screw-HH	40:2	237-42	1	O-Ring
16	3217-11	2	Nut-Hex	41	115-4002	2	Spacer
17	3234-6	14	Screw-HHF	42	340-3	1	Fitting-Straight
18	3234-27	8	Screw-HHF	42:1	237-22	1	O-Ring
19	32128-49	8	Nut-HHF	42:2	237-79	1	O-Ring
20	3256-26	4	Washer-Flat	43	117-1305	1	Tube-HYD
21	3296-45	4	Nut-Hex	44	340-77	2	Fitting-Elbow, 90 DEG
22	114-3091	2	Bar-Thread	44:1	237-22	1	O-Ring
23	119-4557	2	HYD Motor ASM	44:2	237-42	1	O-Ring
24	115-1298	2	Sheave	45	115-4083	1	Hose
25	340-6	4	Fitting-Straight	46	100-4887	1	Fitting-Elbow, 90
25:1	237-30	1	O-Ring	46:1	237-42	1	O-Ring
25:2	237-80	1	O-Ring	47	2412-36	2	Clamp-Hose
26	340-4	4	Fitting-Straight				

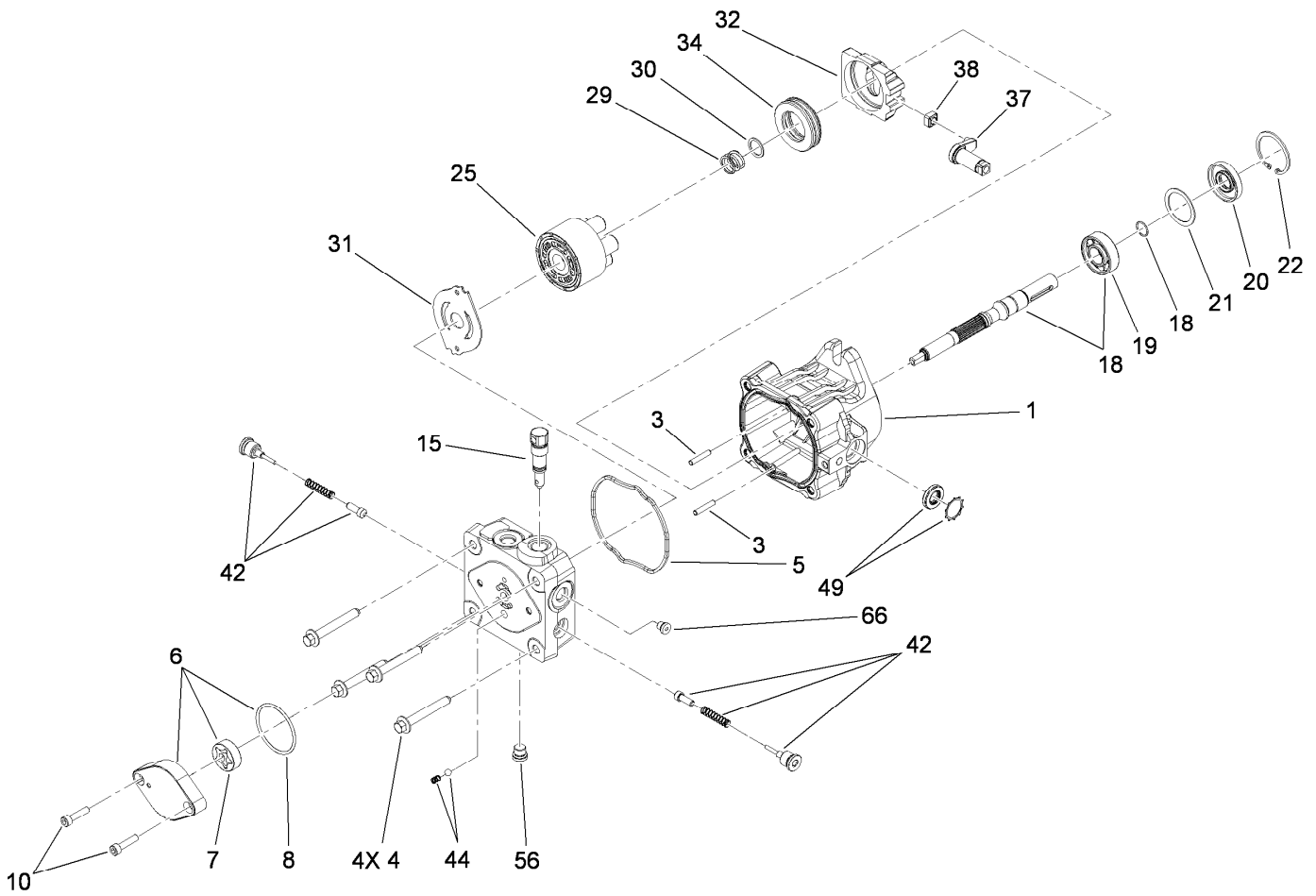

Hydraulic Pump Assembly No. 117-6409

Ref.	Part Number	Qty.	Description	Ref.	Part Number	Qty.	Description
1	115-4464	1	Housing Kit	29	94-1936	1	Spring-Block
3	106-8753	2	Pin-Headless, Straight	30	94-1937	1	Washer-Thrust
4	106-8754	4	Bolt-HF	31	105-6185	1	Plate-Valve
5	106-8755	1	O-Ring	32	94-1907	1	Swashplate-Variable
6	106-8756	1	Charge Pump Kit	34	94-6922	1	Bearing-Thrust
7	104-2122	1	Gerotor ASM	37	115-4458	1	Arm-Trunnion, Tapered Square
8	106-8757	1	O-Ring	38	94-1910	1	Guide-Slot
10	104-2111	2	Capscrew	42	98-3252	2	Valve-Check (W/Poppet)
15	106-8759	1	Bypass Valve Kit	44	106-8760	1	Charge Relief Valve Kit
18	103-2664	1	Input Shaft Kit	49	114-8155	1	Trunnion Seal Kit
19	104-5311	1	Bearing-Ball	56	106-8762	1	Plug-HSH
20	104-5310	1	Seal-Lip	66	106-8763	1	Plug-HSH
21	104-5308	1	Spacer	99	105-6184	1	Seal Overhaul Kit ●
22	104-5309	1	Ring-Retaining				
25	103-2666	1	Cylinder Block Kit				

● Not illustrated

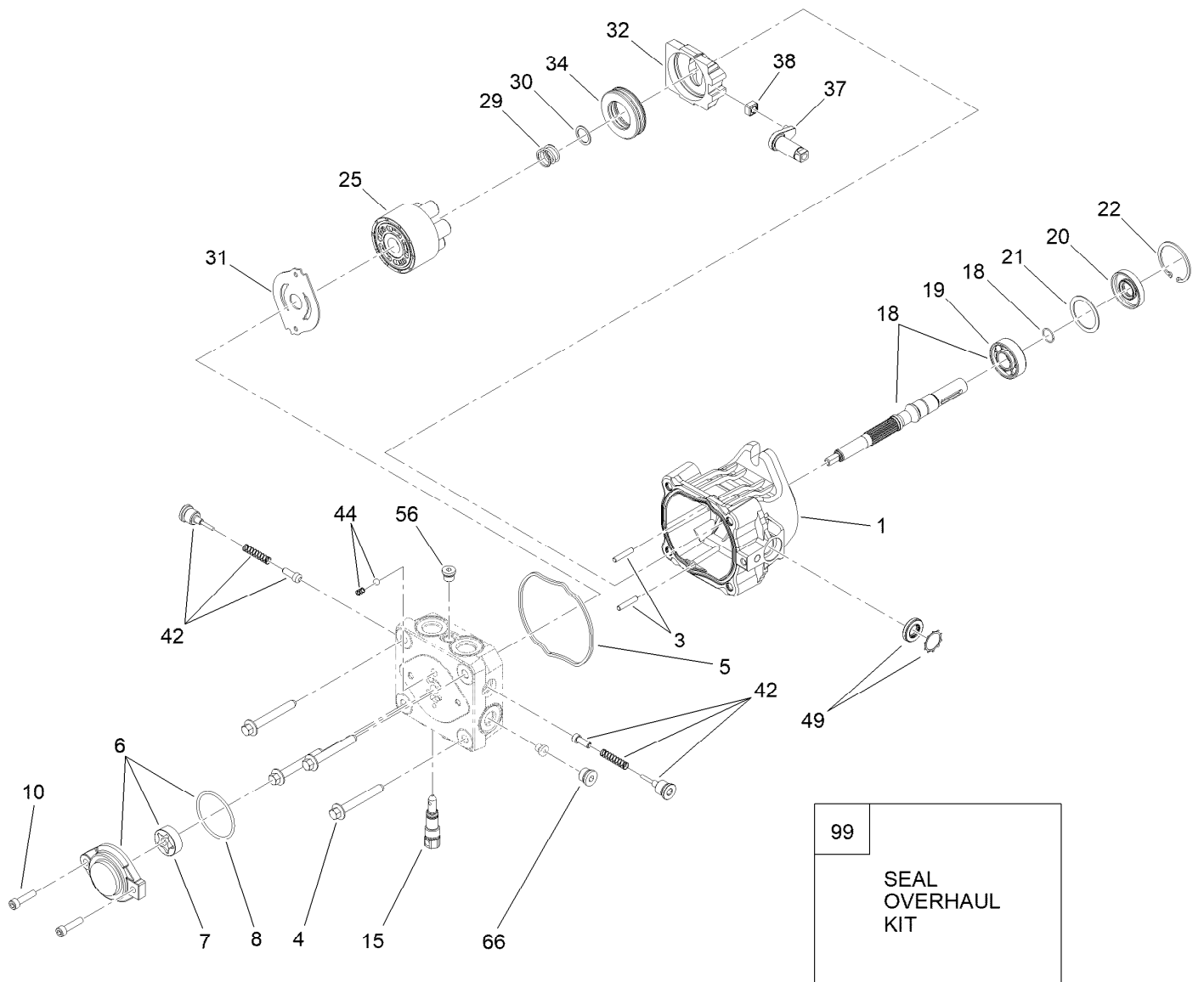

Hydraulic Pump Assembly No. 117-6410

Ref.	Part Number	Qty.	Description	Ref.	Part Number	Qty.	Description
1	115-4464	1	Housing Kit	29	94-1936	1	Spring-Block
3	106-8753	2	Pin-Headless, Straight	30	94-1937	1	Washer-Thrust
4	106-8754	4	Bolt-HF	31	105-6185	1	Plate-Valve
5	106-8755	1	O-Ring	32	94-1907	1	Swashplate-Variable
6	106-8756	1	Charge Pump Kit	34	94-6922	1	Bearing-Thrust
7	104-2122	1	Gerotor ASM	37	115-4458	1	Arm-Trunnion, Tapered Square
8	106-8757	1	O-Ring	38	94-1910	1	Guide-Slot
10	104-2111	2	Capscrew	42	98-3252	2	Valve-Check (W/Poppet)
15	106-8759	1	Bypass Valve Kit	44	106-8760	1	Charge Relief Valve Kit
18	103-2664	1	Input Shaft Kit	49	114-8155	1	Trunnion Seal Kit
19	104-5311	1	Bearing-Ball	56	106-8762	1	Plug-HSH
20	104-5310	1	Seal-Lip	66	106-8763	1	Plug-HSH
21	104-5308	1	Spacer	99	105-6184	1	Seal Overhaul Kit ●
22	104-5309	1	Ring-Retaining				
25	103-2666	1	Cylinder Block Kit				

● Not illustrated

Hydraulic Motor Assembly No. 119-4557 (continued)

<i>Ref.</i>	<i>Part Number</i>	<i>Qty.</i>	<i>Description</i>	<i>Ref.</i>	<i>Part Number</i>	<i>Qty.</i>	<i>Description</i>
1	119-4599	1	Counterbalance Valve ASM	7	100-6131	1	Seal Kit ●
1:1	119-4608	2	Valve-Cartridge	7:1		1	Ring-Back Up ■
2	119-4611	4	Bolt-HSH	7:2		1	Washer-Back Up ■
3	3257-42	1	Key-Woodruff	7:3		1	Seal-Shaft ■
4	120-0691	2	O-Ring	7:4		5	Seal-Ring ■
5	76-0860	1	Shaft-Coupling	7:5		1	Seal-Commutator ■
6	120-5394	1	Motor Housing ASM	7:6		1	Seal-Dirt And Water ■

● Not illustrated

■ Not serviced separately

Engine Assembly

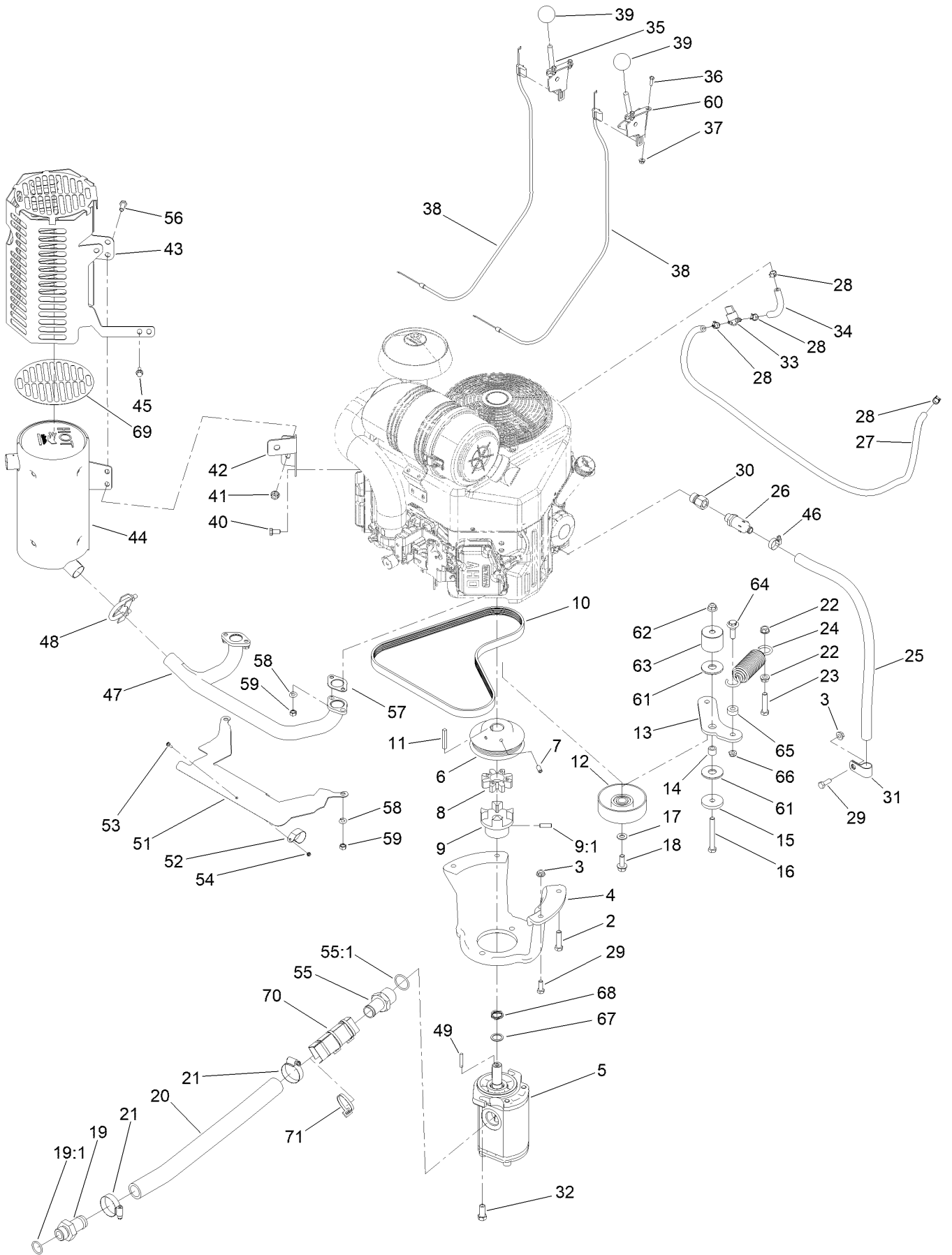

Engine Assembly (continued)

<i>Ref.</i>	<i>Part Number</i>	<i>Qty.</i>	<i>Description</i>	<i>Ref.</i>	<i>Part Number</i>	<i>Qty.</i>	<i>Description</i>
2	323-8	4	Screw-HH	36	3290-134	4	Screw
3	32128-20	3	Nut-HF	37	32128-17	4	Nut-Lock, Flange
4	115-1480-03	1	Mount-Pump	38	115-1211	2	Cable-Control
5	117-6444	1	Gear Pump ASM	39	233-42	2	Knob
6	114-8559-03	1	Pulley-Engine	40	33114-016	2	Screw-HH
7	3246-6	2	Screw-Set, HSH	41	112-2844	3	Nut-HF
8	93-8827	1	Coupler-Spider	42	115-9233-03	1	Bracket-Mount, Muffler
9	114-2933	1	Coupler-Flex	43	137-4879-03	1	Guard-Muffler
9:1	105-4068	1	Screw-Set, HSH	44	120-7536	1	Muffler
10	114-2991	1	Belt-V	45	33103-016	1	Screw-HHF
11	608006	1	Key-Square	46	2412-36	1	Clamp-Hose
12	95-8802	1	Pulley-Idler	47	120-7535	1	Manifold, Muffler
13	125-0252	1	Arm-Idler	48	2112-11	1	Clamp-Muffler
14	1-413088	1	Bushing-Lever, Lift	49	27-8590	1	Key-Square
15	110-9981	1	Washer-Plain	51	115-9227	1	Plate-Shield, Heat
16	323-14	1	Screw-HH	52	115-6488	1	Clamp
17	3256-24	1	Washer-Flat	53	115-6494	1	Screw-Pan
18	3234-11	1	Screw-HHF	54	115-6495	1	Nut-Hex
19	99-3017	1	Fitting	55	354-78	1	Fitting-STR
19:1	237-81	1	O-Ring	55:1	237-146	1	O-Ring
20	114-2917	1	Hose-Suction	56	33114-020	3	Screw-HH
21	2412-111	2	Clamp-Hose, W/Liner	57	1-653313	2	Gasket-Exhaust
22	3290-357	2	Nut-HSF	58	115-6496	4	Washer-Spring
23	323-9	1	Screw-HH	59	115-6611	4	Nut-Hex
24	121-4523	1	Spring-Extension	60	110-5547	1	Lever-Control
25	99-1356	1	Hose-Vent	61	114-0463	2	Washer-Friction, Composite
26	92-6877	1	Valve-Drain, Oil	62	104-8301	1	Nut-HF, NI
27	110-3372	1	Hose-Fuel	63	125-0251	1	Spacer-Idler
28	2412-98	4	Clamp-Hose	64	614672	1	Screw-Shoulder, HWH
29	322-4	3	Screw-HH	65	104-8426	1	Spacer
30	103-1966	1	Adapter-STR	66	3296-59	1	Nut-Lock, NI
31	2412-81	1	Clamp-R	67	115-7210	1	Washer-Thrust
32	324-4	2	Screw-HH	68	121-4517	1	Washer-Wave
33	1-603770	1	Valve-Fuel	69	131-0604	1	Guard-Foil
34	109-0295	1	Hose-Fuel	70	AU112950	2	Protector-Hose
35	108-9730	1	Lever-Control	71	3290-378	3	Tie-Cable

Hydraulic Gear Pump Assembly No. 117-6444

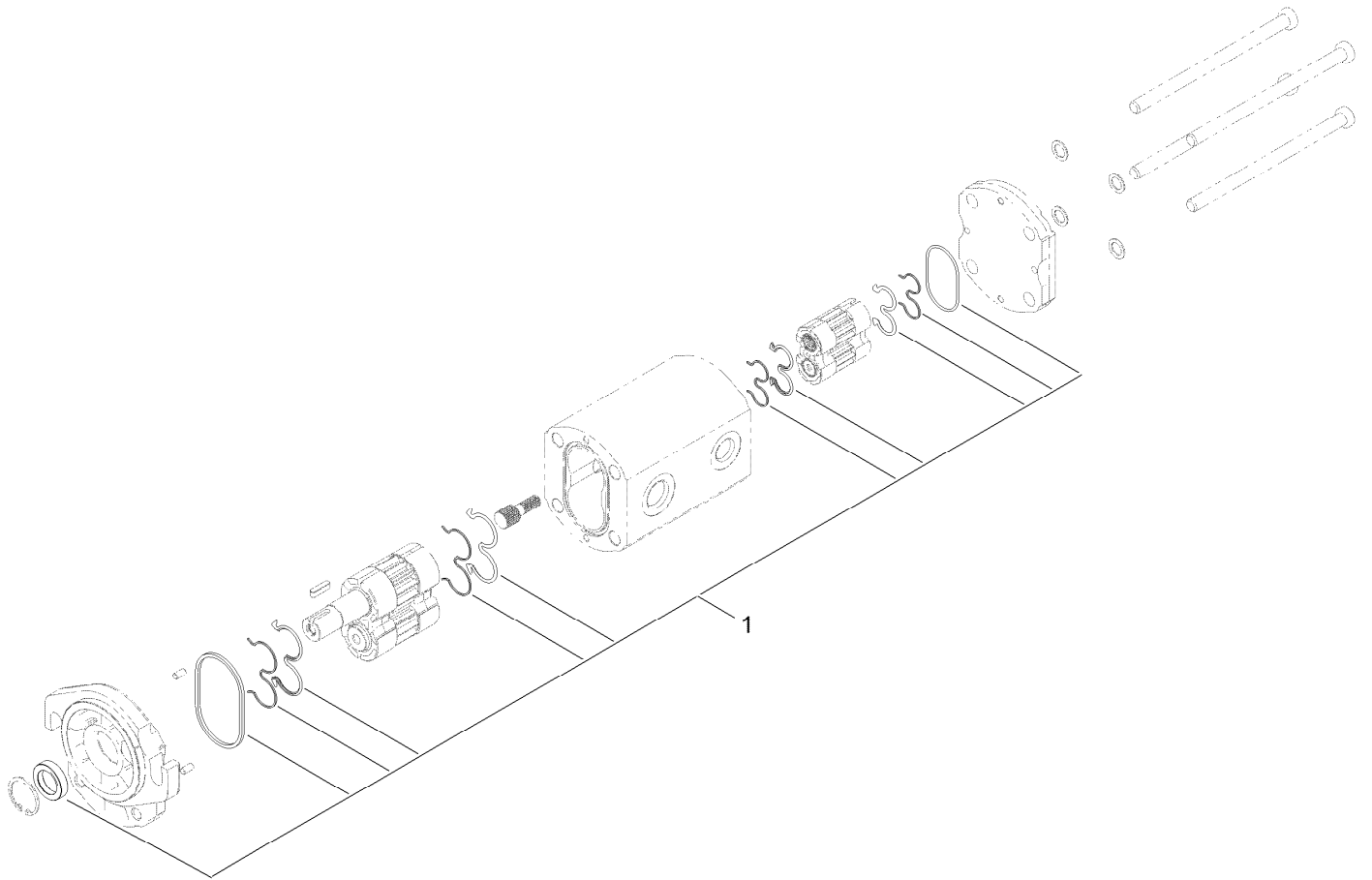

Hydraulic Gear Pump Assembly No. 117-6444 (continued)

<i>Ref.</i>	<i>Part Number</i>	<i>Qty.</i>	<i>Description</i>
1	138-5210	1	Kit-Seal, Pump

Control Assembly

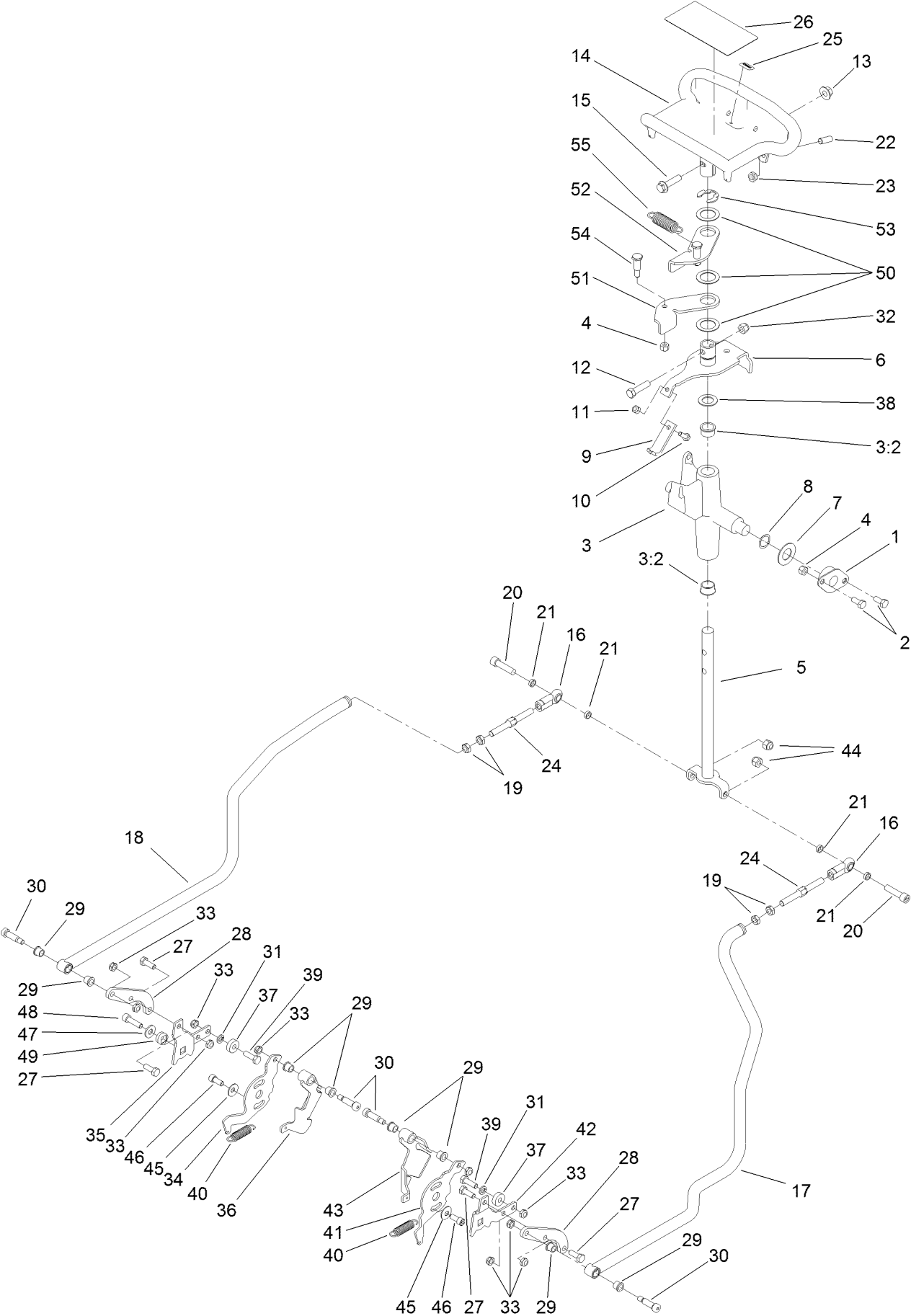

Control Assembly (continued)

<i>Ref.</i>	<i>Part Number</i>	<i>Qty.</i>	<i>Description</i>	<i>Ref.</i>	<i>Part Number</i>	<i>Qty.</i>	<i>Description</i>
1	27-2320	2	Bearing	28	115-1290	2	Plate-Adapter, Control, RH
2	322-3	4	Screw-HH	29	256-116	8	Bushing-Flange
3	106-5737	1	Control Support ASM	30	114-8629	4	Bolt-Shoulder
3:2	256-252	2	Bearing-Flange	31	3253-4	2	Washer-Lock
4	3296-29	6	Nut-Lock, NI	32	3296-39	1	Nut-Lock, NI
5	117-6335	1	Rod-Drive	33	3296-47	10	Nut-Lock,NI
6	112-2783	1	Lever-Pivot	34	115-6535	1	Plate-Base, RH
7	3256-39	2	Washer-Flat	35	115-6536	1	Plate-Arm, Return
8	95-3703	2	Washer-Spring, Wave	36	115-6636	1	Pivot-RH
9	115-1204	1	Plate-Neutral	37	251-259	2	Bearing-Ball
10	321-4	1	Screw-HH	38	257-8	1	Washer-Thrust
11	3296-42	1	Nut-Lock, NI	39	322-5	2	Screw-HH
12	323-8	1	Screw-HH	40	121-4409	2	Spring-Extension
13	32128-43	1	Nut-Flange	41	115-6549	1	Plate-Base, LH
14	120-5380-03	1	Handle-Control	42	115-6628	1	Plate-Arm, Return, LH
15	3234-18	1	Screw-HHF	43	115-6637	1	Pivot-LH
16	103-1167	2	Joint-Ball End, LH	44	3296-39	2	Nut-Lock, NI
17	121-4511	1	Rod-Control, LH	45	3290-456	2	Washer-Belleville
18	121-4512	1	Rod-Control, RH	46	3273-14	2	Screw-HSH
19	3220-3	4	Nut-HJ	47	3256-3	2	Washer-Flat
20	3274-2	2	Screw-HSH	48	94-3559	2	Screw-HSH
21	108-0634	4	Spacer-Plate, Retaining	49	117-6429	2	Lock-Trunion
22	3247-6	2	Screw-Set	50	108-9743	3	Washer-Plain
23	3218-3	2	Nut-Jam	51	98-8407	1	Lever-Return, RH
24	121-4506	2	Link-Control, Adjustment	52	98-8408	1	Lever-Return, LH
25	98-1459	1	Decal	53	32151-91	1	Ring-Retaining
26	115-4020	1	Decal-Traction	54	63-2650	2	Screw-Shoulder
27	322-4	4	Screw-HH	55	108-4724	1	Spring-Extension

Frame and Cutter Wheel Assembly

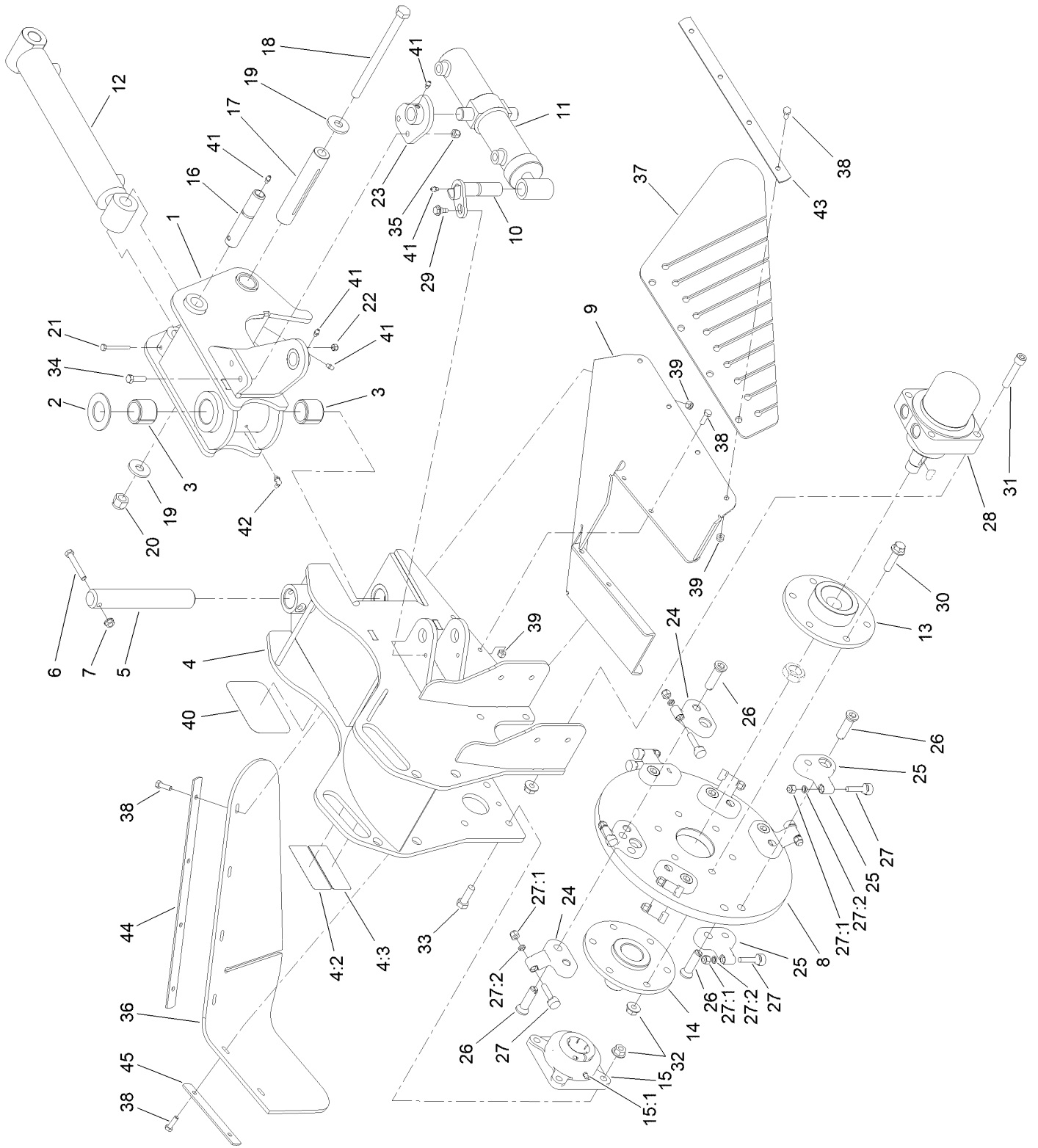

Frame and Cutter Wheel Assembly (continued)

<i>Ref.</i>	<i>Part Number</i>	<i>Qty.</i>	<i>Description</i>	<i>Ref.</i>	<i>Part Number</i>	<i>Qty.</i>	<i>Description</i>
1	117-6390-01	1	Pivot	23	115-9392-01	1	Mount-Cylinder
2	99-2707	1	Washer	24	115-9384	8	Pocket-Angled
3	99-2713	2	Bushing-Tension	25	115-9388	4	Pocket-Straight
4	119-4612	1	Frame ASM	26	115-9386	12	Bolt-HSH, RH
4:2	107-9366	1	Decal-Warning	27	115-9385	12	Grinder Tooth ASM
4:3	93-7321	1	Decal-Danger	27:1	3296-39	1	Nut-Lock, NI
5	117-6445	1	Pin-Pivot	27:2	121-4365	1	Spacer-Tooth
6	323-47	1	Screw-HH	28	127-9603	1	HYD Motor ASM
7	3290-357	1	Nut-HSF	29	99-5105	1	Screw-Shoulder
8	119-5050-03	1	Wheel-Cutter	30	3234-27	6	Screw-HHF
9	119-5064-03	1	Guard-Chip	31	3274-71	4	Screw-HSH
10	94-9797	1	Pin-Pivot	32	32128-49	14	Nut-HHF
11	117-6441	1	HYD Cylinder ASM	33	325-6	4	Screw-HH
12	121-1955	1	HYD Cylinder ASM	34	323-7	2	Screw-HH
13	119-4570-03	1	Hub-Drive	35	3296-39	2	Nut-Lock, NI
14	115-9395-03	1	Shaft-Stub	36	119-5060	1	Shield-Rubber, RH
15	104-2026	1	Bearing	37	119-5061	1	Shield-Rubber, LH
15:1	302-2	1	Fitting-Grease	38	322-5	14	Screw-HH
16	120-7352	1	Pin-Pivot	39	3296-29	14	Nut-Lock, NI
17	121-4571	1	Spacer-Pivot	40	104-3989	1	Decal
18	117-6327	1	Bolt-HH	41	302-5	5	Fitting-Grease
19	104-9216	2	Washer-Hardened	42	302-40	1	Fitting-Grease, 90 DEG
20	3296-53	1	Nut-Lock, NI	43	119-5118-03	1	Strap-Retainer, LH
21	321-18	1	Screw-HH	44	119-5119-03	1	Strap-Retainer, Rear
22	3296-42	1	Nut-Lock, NI	45	119-5120-03	1	Strap-Retainer, RH

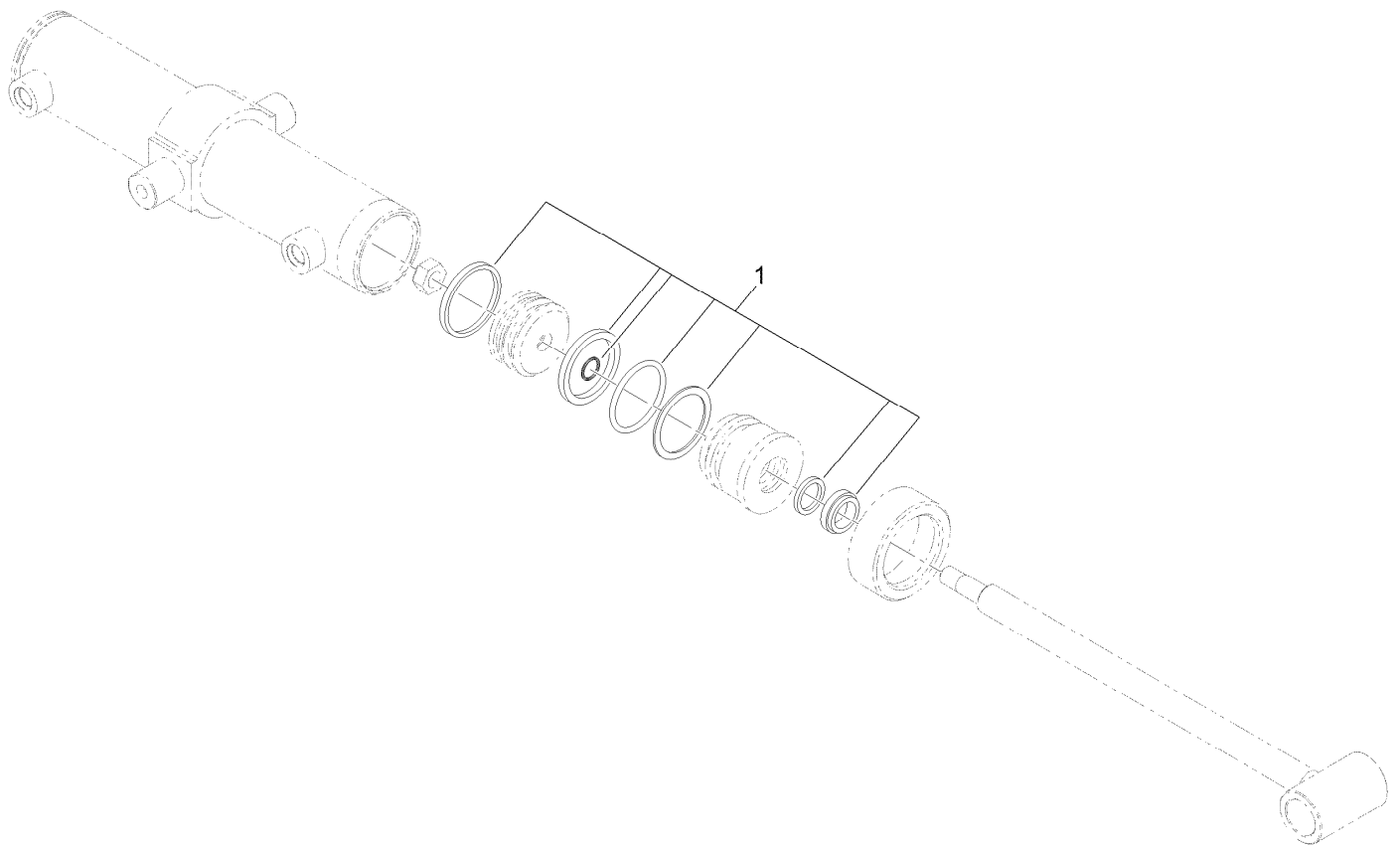

Hydraulic Cylinder Assembly No. 117-6441

<i>Ref.</i>	<i>Part Number</i>	<i>Qty.</i>	<i>Description</i>
1	119-4632	1	Seal Kit

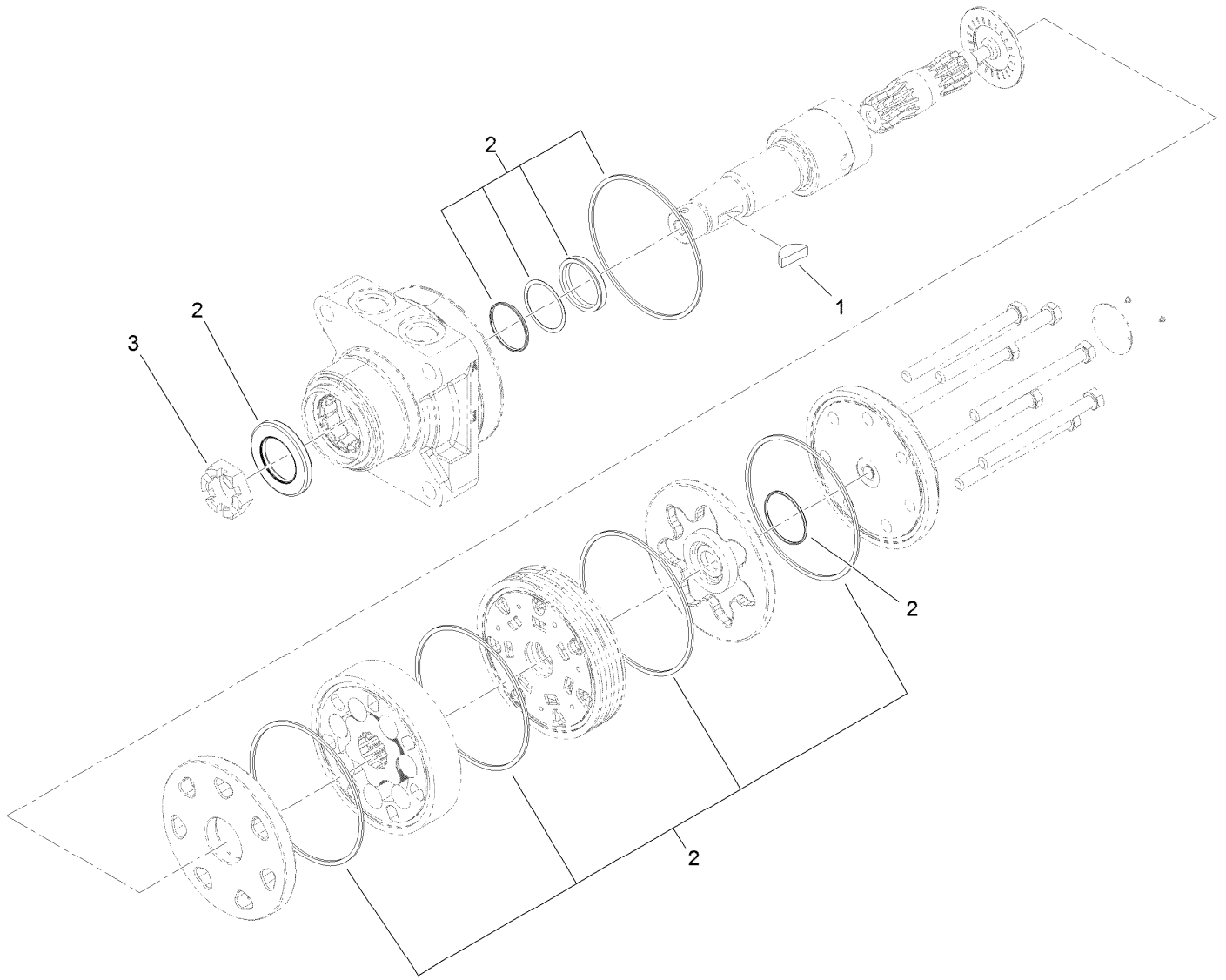

Hydraulic Motor Assembly No. 127-9603

<i>Ref.</i>	<i>Part Number</i>	<i>Qty.</i>	<i>Description</i>
1	3257-42	1	Key-Woodruff
2	119-4631	1	Seal Kit
3	106-8159	1	Nut-Lock

Hydraulic Cylinder Assembly No. 121-1955

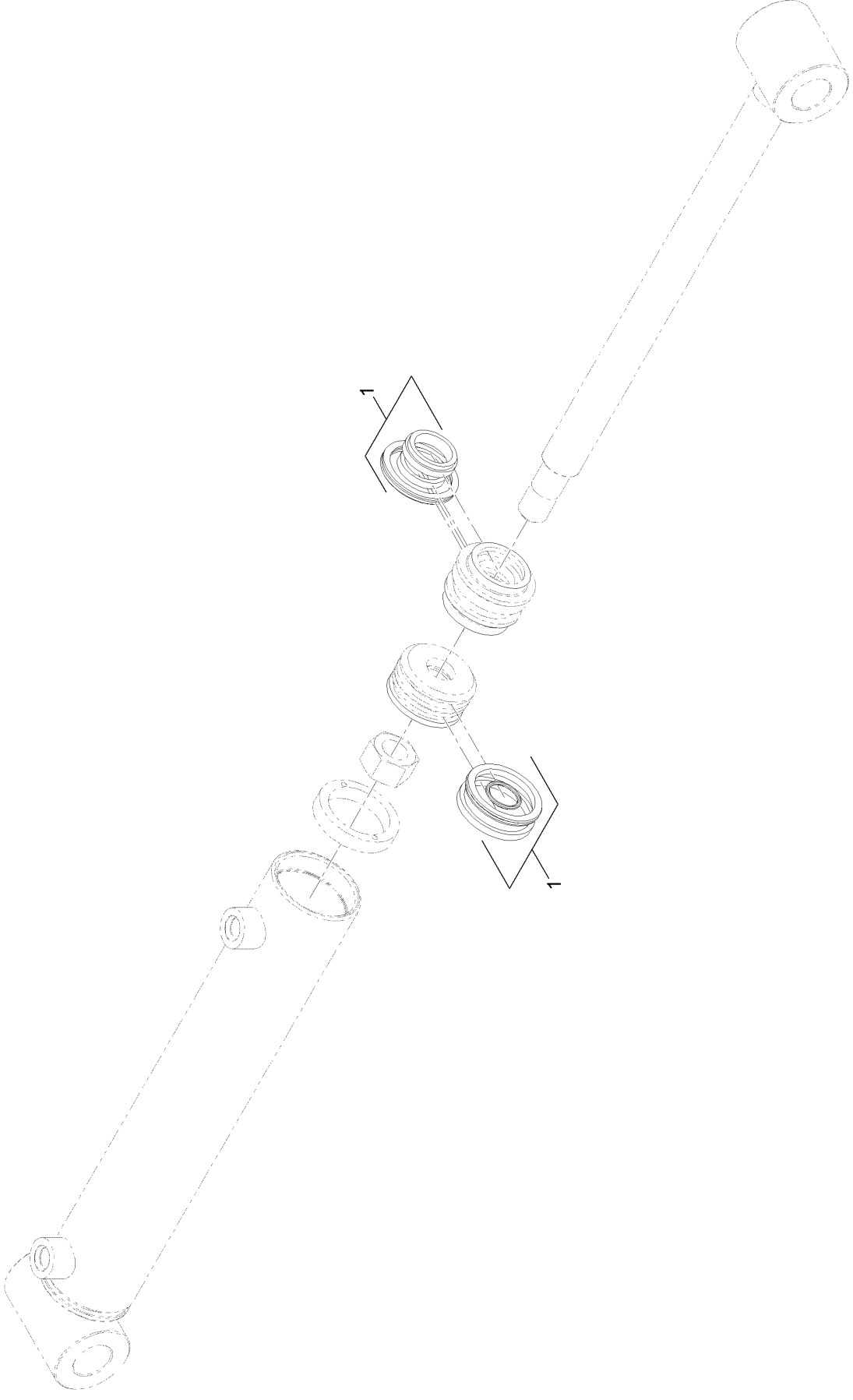

Hydraulic Cylinder Assembly No. 121-1955 (continued)

<i>Ref.</i>	<i>Part Number</i>	<i>Qty.</i>	<i>Description</i>
1	131-0665	1	Seal Kit

Tower and Fuel Tank Assembly

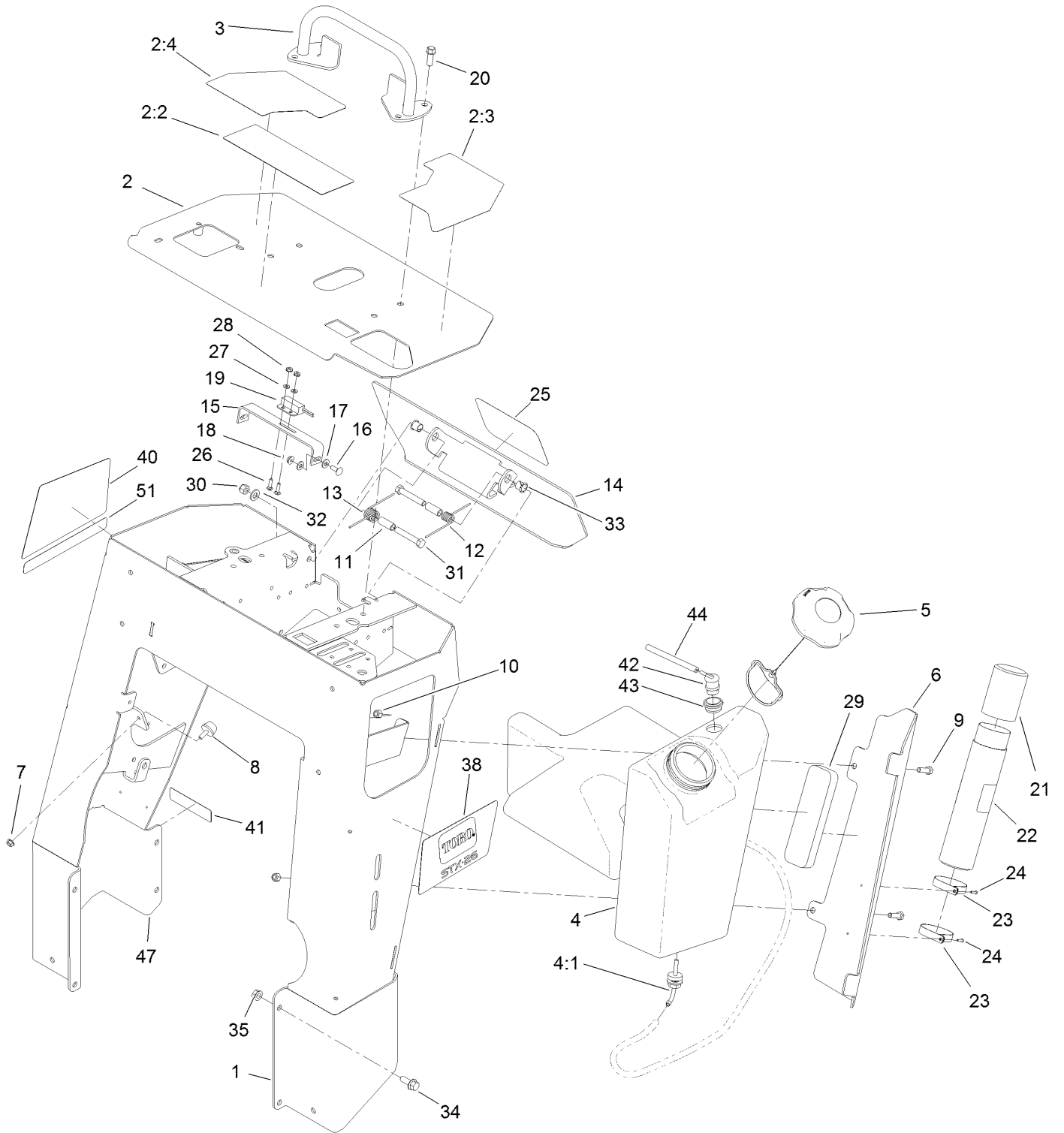

Tower and Fuel Tank Assembly (continued)

<i>Ref.</i>	<i>Part Number</i>	<i>Qty.</i>	<i>Description</i>	<i>Ref.</i>	<i>Part Number</i>	<i>Qty.</i>	<i>Description</i>
1	119-5100-01	1	Tower	21	104-7048	1	Cap-Housing
2	119-4613	1	Control Panel ASM	22	104-7050	1	Tube-Manual
2:2	119-4606	1	Decal-Warning	23	2412-120	2	Clamp-R
2:3	119-4560	1	Decal-Console, LH	24	3269-17	2	Rivet-Pop
2:4	119-4561	1	Decal-Console, RH	25	105-1217	1	Decal
3	106-7715	1	Bar-Reference	26	3229-20	2	Screw-CARR
4	120-7359	1	Tank-Fuel	27	3256-51	2	Washer-Flat
4:1	103-2605	1	Fitting-Fuel, Bulkhead	28	32149-7	2	Nut-Keps
5	137-4119	1	Cap-Fuel, Ratcheting	29	107-7507	1	Pad-Foam
6	119-5086-01	1	Bracket-Cover, Tank	30	3296-39	2	Nut-Lock, NI
7	32128-33	1	Nut-HF	31	323-11	2	Screw-HH
8	1-523420	1	Bumper	32	3256-24	2	Washer-Flat
9	322-5	2	Screw-HH	33	256-257	2	Bushing-Nyliner
10	3296-29	2	Nut-Lock, NI	34	3234-11	8	Screw-HHF
11	114-1337	2	Spacer-Spring	35	32128-40	8	Nut-Flange
12	98-8425	1	Spring-Torsion, LH	38	119-4563	1	Decal-Side, LH
13	98-8424	1	Spring-Torsion, RH	40	119-4565	1	Decal-Side, RH
14	112-2786-03	1	Plate-Reverse	41	133-8062	1	Decal-Arrestor, Spark
15	100-1263	1	Plate-Switch	42	119-3547	1	Valve-Vent, Fuel
16	3229-1	2	Screw-CARR	43	114-0284	1	Grommet
17	3256-22	4	Washer-Flat	44	117-6395	1	Hose-Vent, Tank
18	32149-2	2	Nut-Keps	47	93-9084	2	Decal-Point, Lift
19	100-1270	1	Switch-Proximity	51	130-7577	1	Decal-Intellisweep
20	95-1726	4	Screw-Taptite				

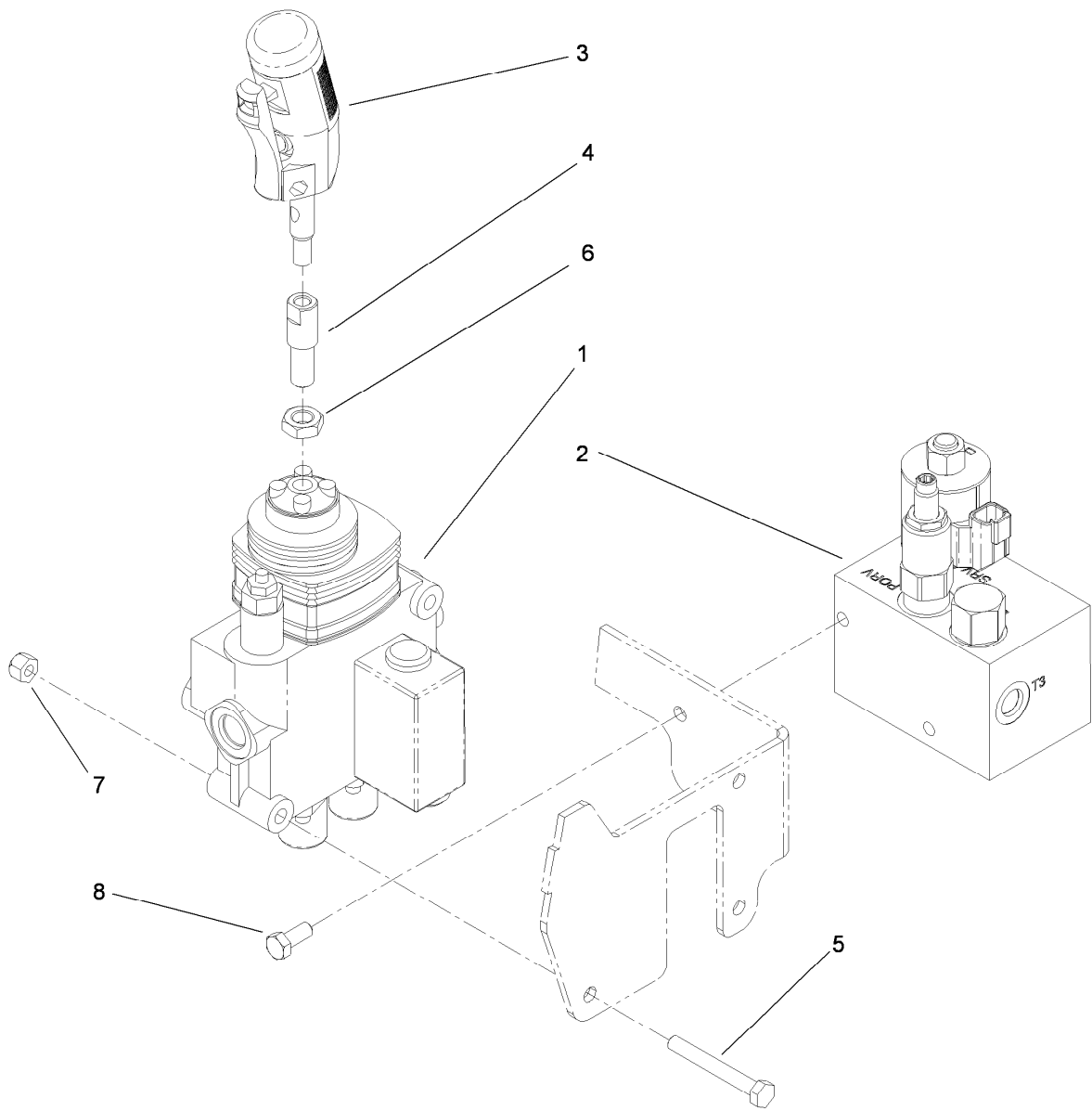

Control Valve Assembly

Ref.	Part Number	Qty.	Description
1	119-4585	1	HYD Valve ASM
2	119-4586	1	Cutter Wheel Valve ASM
3	119-4587	1	Two Button Handle Grip ASM
4	119-5103	1	Adapter-Handle
5	322-12	3	Screw-HH
6	51-2070	1	Nut
7	3296-29	3	Nut-Lock, NI
8	322-3	2	Screw-HH

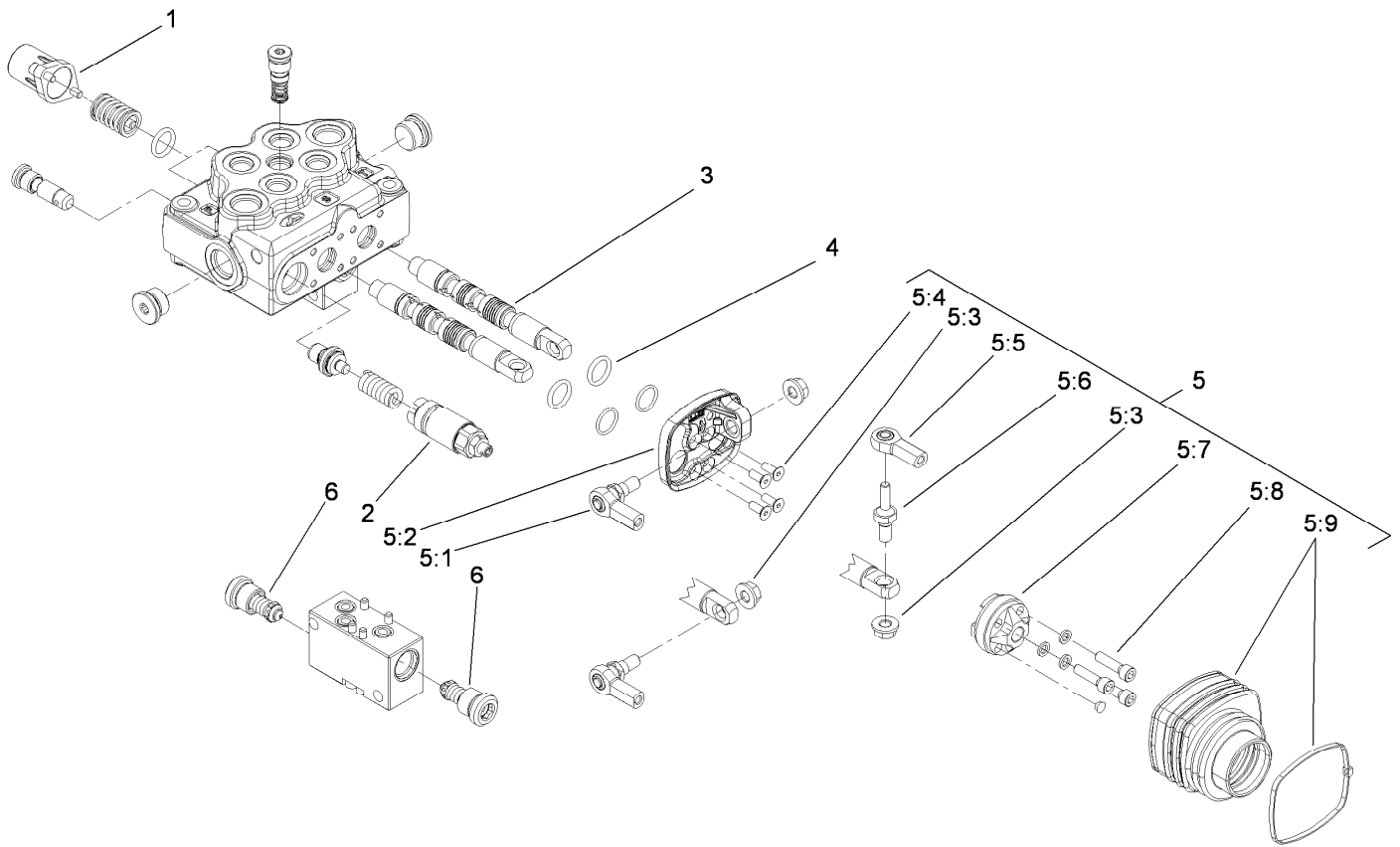

Control Valve Assembly No. 119-4585

Ref.	Part Number	Qty.	Description
1	100-8801	2	High Force Spring Kit
2	100-8805	1	Valve-Relief
3	114-8625	2	Valve-Spool
4	106-7719	4	Seal-Valve
5	119-4622	1	Joystick Kit
5:1	119-4623	2	Joint-Joystick
5:2	119-4624	1	Base-Joystick
5:3	117-1350	3	Nut-HF, Lock
5:4	119-4625	4	Screw-Joystick
5:5	119-4626	1	Joint-Joystick
5:6	119-4627	1	Pin-Spool
5:7	119-4628	1	Holder-Joystick
5:8	3273-42	3	Screw-HSH
5:9	119-4629	1	Boot-Joystick
6	119-4630	2	Valve Kit

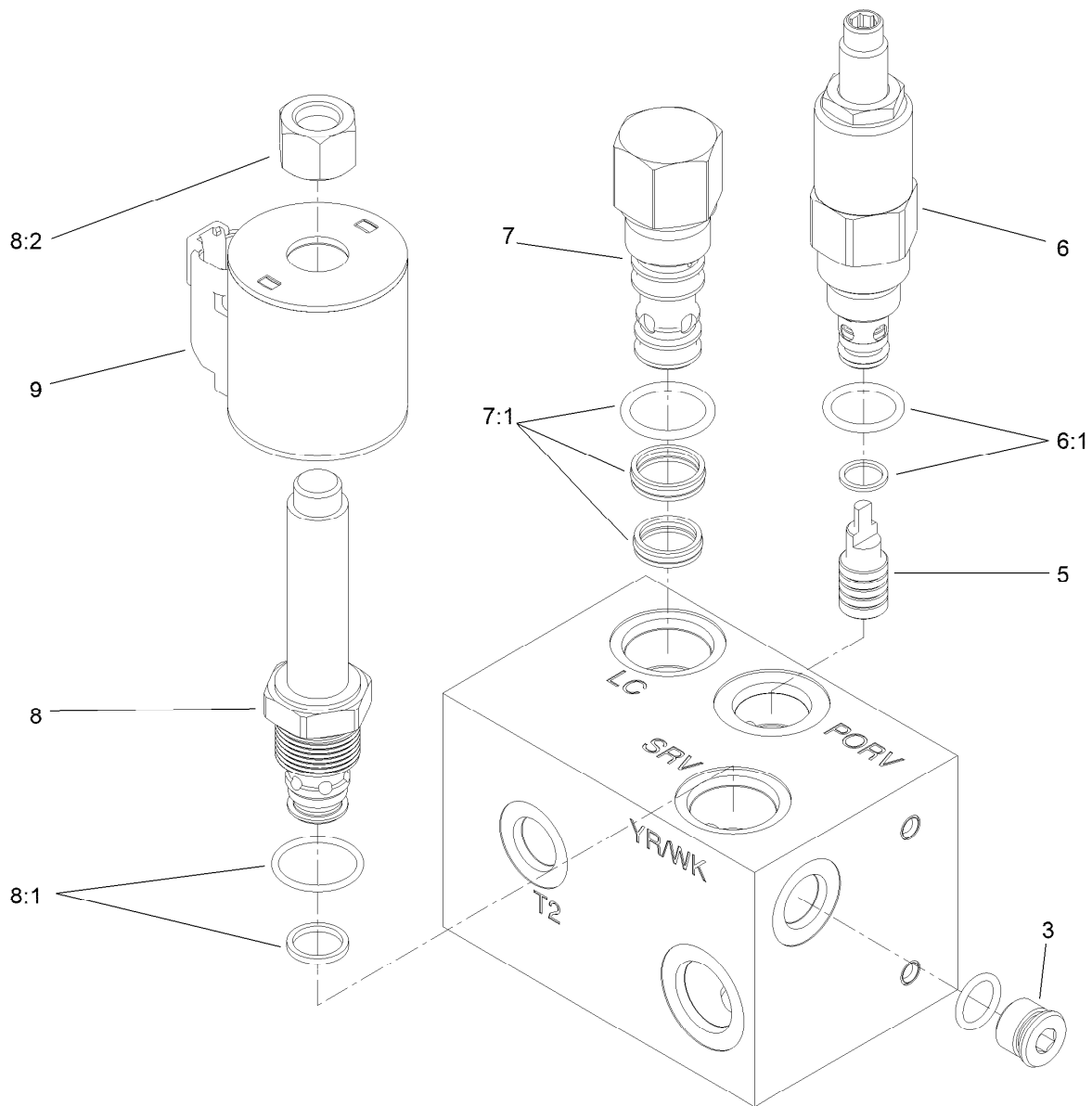

Cutter Wheel Valve Assembly No. 119-4586

<i>Ref.</i>	<i>Part Number</i>	<i>Qty.</i>	<i>Description</i>
3	106-1026	1	Plug-HYD
5	105-9157	1	Piston-Pilot
6	119-4620	1	Valve-Relief
6:1	105-9156	1	Seal Kit
7	105-9153	1	Element-Logic, Vented
7:1	119-2159	1	Seal Kit ●
8	130-7609	1	Valve-Relief,
8:1	110-6316	1	Seal Kit
8:2	130-8180	1	Nut-Coil (9/16-24 Unef-2B)
9	119-4619	1	Coil-Solenoid

● Not illustrated

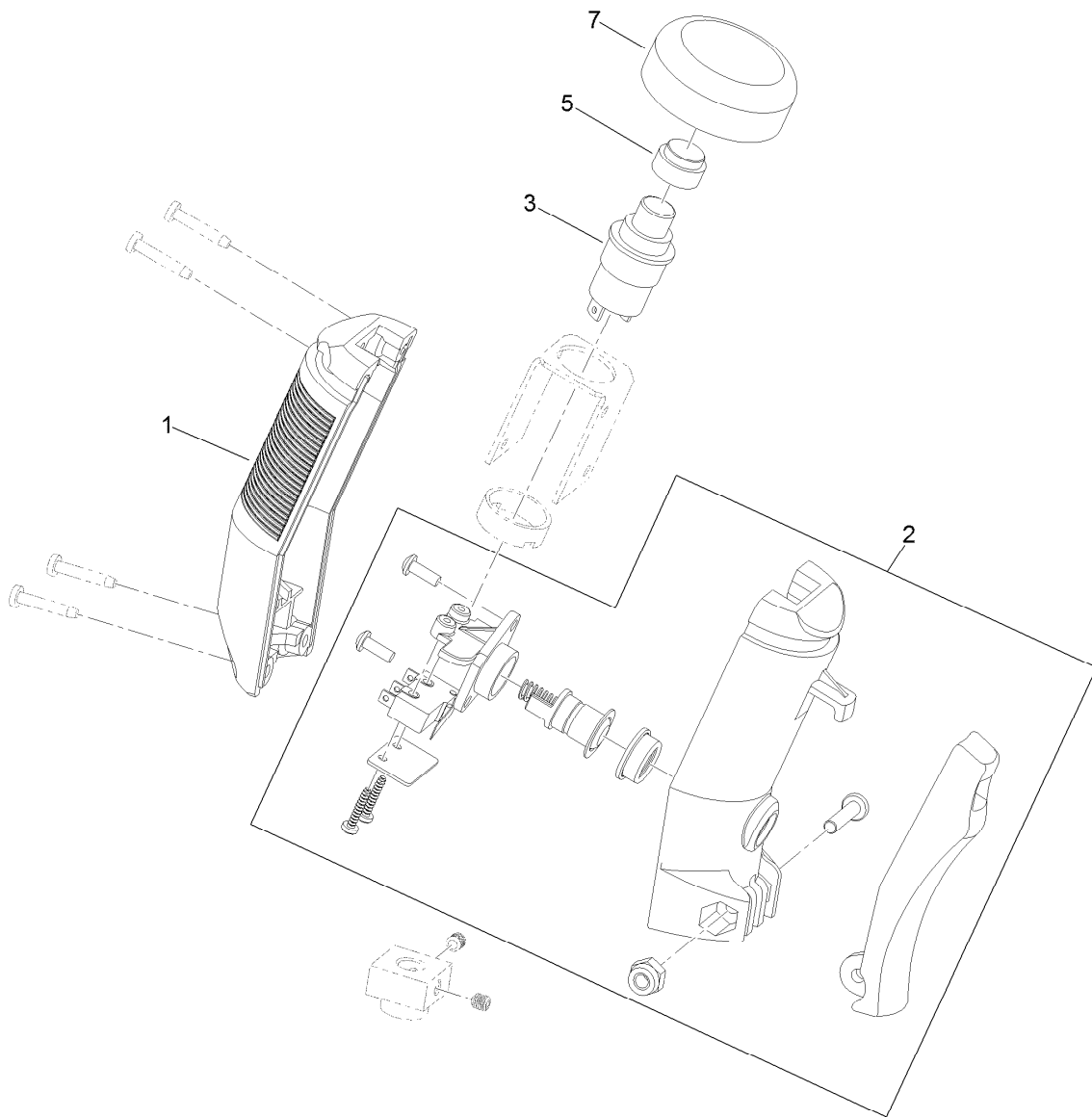

Two-Button Handle Grip Assembly No. 119-4587

<i>Ref.</i>	<i>Part Number</i>	<i>Qty.</i>	<i>Description</i>
1	119-4637	1	Halve-Handle
2	132-8660	1	Swich Kit
3	119-4640	1	Button-Push, Top
5	119-4642	1	Button-Actuator
7	119-4641	1	Boot-Button

Oil Cooler Assembly

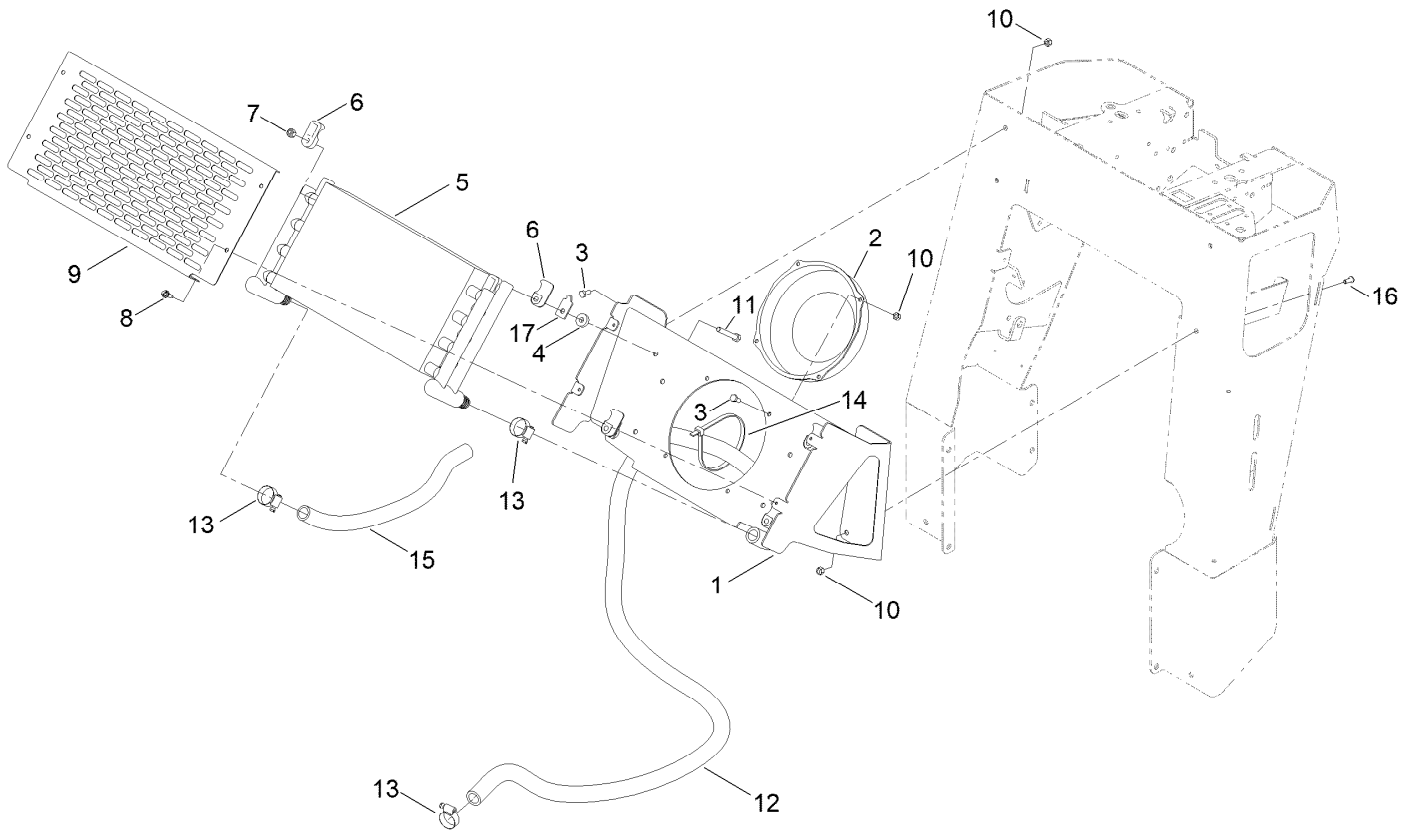

Oil Cooler Assembly (continued)

<i>Ref.</i>	<i>Part Number</i>	<i>Qty.</i>	<i>Description</i>	<i>Ref.</i>	<i>Part Number</i>	<i>Qty.</i>	<i>Description</i>
1	147-7009-01	1	Cooler Mount ASM [red]	10	3296-42	8	Nut-Lock, NI
2	104-2809	1	Fan	11	322-11	4	Screw-HH
3	321-3	7	Screw-HH	12	119-4607	1	Hose-Return
4	26-4840	4	Spacer-Pin, Mounting	13	2412-129	3	Clamp-Hose
5	117-6320	1	Cooler-Oil	14	3334-945	1	Tie-Cable
6	131-0733	8	Clamp	15	119-4571	1	Hose-Return
7	3296-29	4	Nut-Lock, NI	16	3274-31	1	Screw-HSBH
8	32104-95	4	Screw-HWH	17	131-0642	4	Plate-Support, Clamp
9	119-4633-01	1	Cover-Cooler				

Hydraulic Hose Routing Assembly

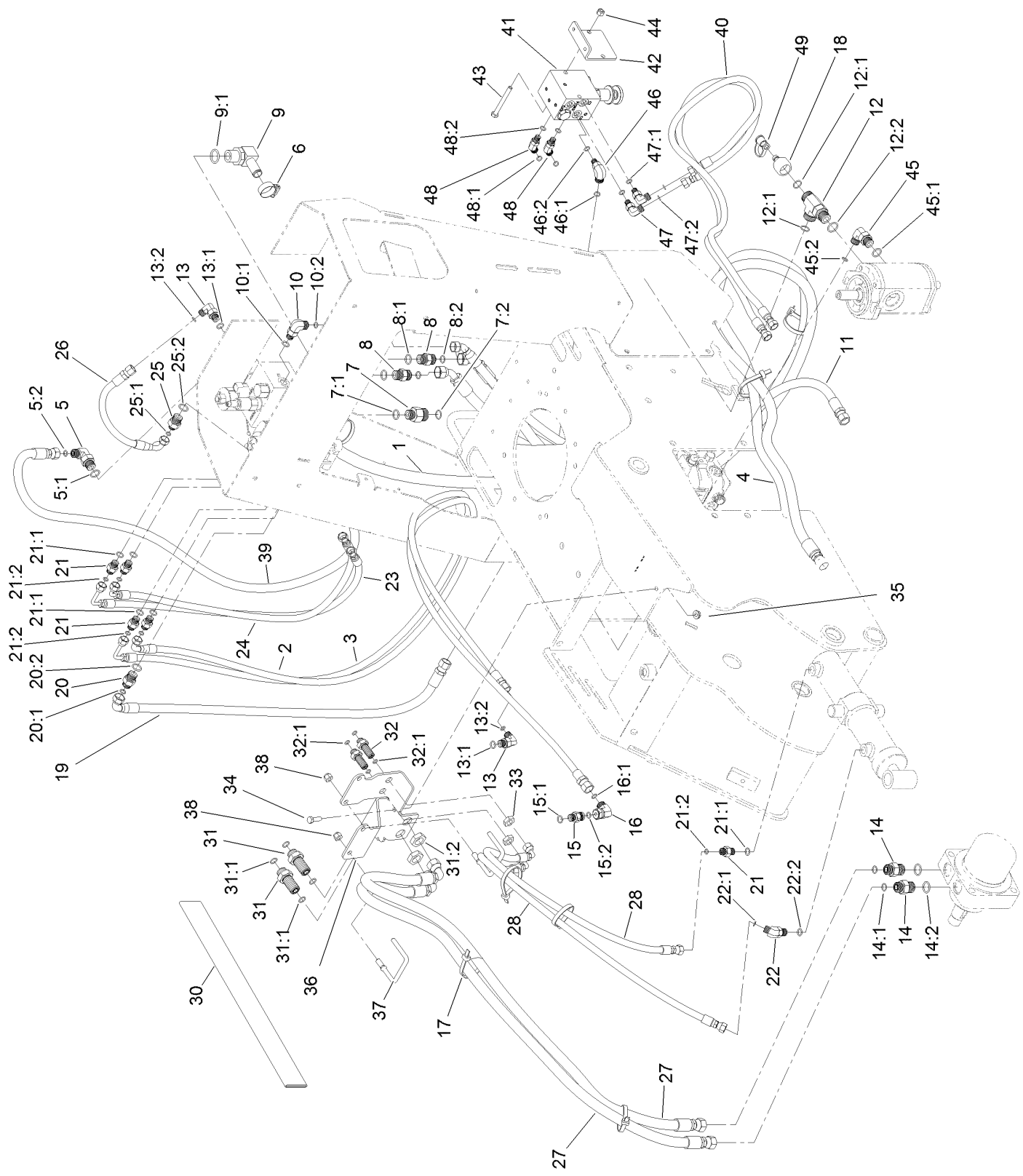

Hydraulic Hose Routing Assembly (continued)

<i>Ref.</i>	<i>Part Number</i>	<i>Qty.</i>	<i>Description</i>	<i>Ref.</i>	<i>Part Number</i>	<i>Qty.</i>	<i>Description</i>
1	119-4589	1	Hose-HYD	22	340-137	1	Fitting
2	119-4590	1	Hose-HYD	22:1	237-21	1	O-Ring
3	119-4601	1	Hose-HYD	22:2	237-42	1	O-Ring
4	144-7457	2	Hose ASM-HYD	23	130-7602	1	Hose-HYD
5	340-18	1	Fitting-HYD, 90 DEG	24	130-7603	1	Hose-HYD
5:1	237-79	1	O-Ring	25	340-133	1	Fitting-STR
5:2	237-22	1	O-Ring	25:1	237-79	1	O-Ring
6	2412-129	1	Clamp-Hose	25:2	237-21	1	O-Ring
7	340-155	1	Fitting-Straight	26	119-4594	1	Hose-HYD
7:1	237-79	1	O-Ring	27	144-7458	2	Hose ASM-HYD
7:2	237-151	1	O-Ring	28	144-7459	2	Hose ASM-HYD
8	340-4	2	Fitting-Straight	30	99-5648	1	Sleeve-Protective
8:1	237-30	1	O-Ring	31	340-161	2	Fitting-Bulkhead
8:2	237-79	1	O-Ring	31:1	237-30	2	O-Ring
9	353-987	1	Fitting-Elbow, 90	31:2	340-127	1	Nut-Bulkhead
9:1	237-81	1	O-Ring	32	94-1444	2	Union-Bulkhead
10	340-77	1	Fitting-Elbow, 90 DEG	32:1	237-21	2	O-Ring
10:1	237-22	1	O-Ring	33	340-78	2	Nut-Lock
10:2	237-42	1	O-Ring	34	322-5	1	Screw-HH
11	119-4602	1	Hose-HYD	35	32128-20	1	Nut-HF
12	340-22	1	Fitting-Tee	36	125-0263-03	1	Bracket-Bulkhead
12:1	237-65	2	O-Ring	37	121-4555	2	Guide-Hose
12:2	237-80	1	O-Ring	38	3296-39	2	Nut-Lock, NI
13	340-82	2	Fitting-Elbow, 90 DEG	39	130-7604	1	Hose-HYD
13:1	237-42	1	O-Ring	40	130-7605	2	Hose-HYD
13:2	237-21	1	O-Ring	41	121-4466	1	Sweep Manifold ASM
14	340-6	2	Fitting-Straight	42	130-1014-03	1	Bracket-Valve
14:1	237-30	1	O-Ring	43	322-14	2	Screw-HH
14:2	237-80	1	O-Ring	44	3296-29	2	Nut-Lock, NI
15	115-4081	1	Valve-Check	45	340-18	1	Fitting-HYD, 90 DEG
15:1	237-42	1	O-Ring	45:1	237-79	1	O-Ring
15:2	237-22	1	O-Ring	45:2	237-22	1	O-Ring
16	340-159	1	Elbow-90	46	340-97	1	Fitting-Elbow, 90 DEG
16:1	237-22	2	O-Ring	46:1	237-22	1	O-Ring
17	3334-945	13	Tie-Cable	46:2	237-78	1	O-Ring
18	86-5860	1	Nipple	47	340-132	2	Fitting-Elbow, 90 DEG
19	119-4592	1	Hose-HYD	47:1	237-78	1	O-Ring
20	340-3	1	Fitting-Straight	47:2	237-21	1	O-Ring
20:1	237-22	1	O-Ring	48	340-103	2	Fitting-HYD, 45 DEG
20:2	237-79	1	O-Ring	48:1	237-78	1	O-Ring
21	340-1	5	Fitting-Straight	48:2	237-21	1	O-Ring
21:1	237-21	1	O-Ring	49	354-79	1	Cap-Dust
21:2	237-42	1	O-Ring				

Battery and Electrical Assembly (continued)

<i>Ref.</i>	<i>Part Number</i>	<i>Qty.</i>	<i>Description</i>	<i>Ref.</i>	<i>Part Number</i>	<i>Qty.</i>	<i>Description</i>
1	119-4555	1	Harness-Wire	12	32128-49	2	Nut-HHF
1:1	109103	1	Fuse-Blade, 30 Amp	13	106-8945	1	Cable-Battery, Positive
1:2	109102	1	Fuse-Blade, 25 Amp	14	3256-2	2	Washer-Flat
1:3	109101	1	Fuse-Blade, 20 Amp	15	32149-1	2	Nut-Keps
1:4	116-0053	1	Cap-Plug	16	322-3	2	Screw-HH
2	98-7249	2	Relay	17	117-6422	1	Cable-Battery, Black
3	63-8360	1	Key-Ignition	18	120-2244	1	Hourmeter
4	88-9830	1	Key Switch ASM	19	3296-2	5	Nut-Lock, NI
4:1	3254-5	1	Washer-Lock	20	3255-8	1	Washer-Lock
4:2	218-461	1	Nut-HH	21	107-1572	1	Washer-Lock
5	105-3150-01	1	Tray-Battery	22	107-1571	1	Nut-Hex
7	99-7421	1	Battery - Wet (300 CCA, 12 V)	23	32105-13	5	Screw-HWH
8	115-6621-03	1	Plate-Hold Down, Battery	24	62-4300	1	Pad-Skid, Anti
9	104-8567	2	Holdown-Battery	25	33114-016	1	Screw-HH
10	3296-42	2	Nut-Lock, NI	26	33004-00	1	Nut-HF
11	3234-6	2	Screw-HHF	27	100-6170	1	Module-Delay
				28	119-4604	1	Harness

Attachments and Accessories

For 23208 STX-26 Stump Grinder

Product Name	Model/Part
Spark Arrestor Screen	94-8157
CE Kit	22368
Semi-Gloss Black Spray Paint.....	361-9
New Red Paint - Gallon	361-11
Decal Kit	145-6940

Notes:

Notes:

Notes:



Count on it.