



**Dingo<sup>®</sup> 322**

**Dingo<sup>®</sup> Compact Utility Loader**

**Model No. 22305—220000001 and Up**

**Operator's Manual**



## Warning



**The engine exhaust from this product contains chemicals known to the State of California to cause cancer, birth defects, or other reproductive harm.**

**Important** Because in some areas there are local, state, or federal regulations requiring that a spark-arrester be used on engines, a spark-arrester is available as an option for the traction unit. If a spark-arrester is required, contact your Toro dealer. Genuine Toro approved spark-arresters are approved by the USDA Forestry Service. It is a violation of the State of California PRC Section 4442 to use or operate the engine on any forest-covered, brush-covered, or grass-covered land, unless the engine is equipped with a spark-arrester, maintained in working order, or the engine is constricted, equipped, and maintained for the prevention of fire.

This spark ignition system complies with Canadian ICES-002.

Ce système d'allumage par étincelle de véhicule est conforme à la norme NMB-002 du Canada.

**The enclosed Engine Owner's Manual is supplied for information regarding The U.S. Environmental Protection Agency (EPA) and the California Emission Control Regulation of emission systems, maintenance and warranty.**

**Keep this engine Owner's Manual with your unit. Should this engine Owner's Manual become damaged or illegible, replace immediately. Replacements may be ordered through the engine manufacturer.**

# Contents

	Page
Introduction .....	2
Safety .....	3
Safe Operating Practices .....	3
Slope Chart .....	6
Safety and Instruction Decals .....	7
Assembly .....	8
Loose Parts .....	8
Installing the Valve Lever .....	8
Activating the Battery .....	9
Specifications .....	10
Attachments .....	10
Stability Data .....	11
Before Operating .....	11
Adding Fuel .....	12
Using Stabilizer/Conditioner .....	12

	Page
Checking the Oil Level .....	12
Removing Debris from the Traction Unit .....	13
Checking the Hydraulic Fluid .....	13
Tire pressure .....	13
Operation .....	14
Traction Unit Overview .....	14
Controls .....	15
Starting and Stopping the Engine .....	16
Driving Forward or Backward .....	17
Stopping the Traction Unit .....	17
Moving a Non-functioning Traction Unit .....	17
Using the Cylinder Locks .....	18
Installing and Removing Attachments .....	18
Securing the Traction Unit for Transport .....	20
Maintenance .....	20
Recommended Maintenance Schedule .....	20
Removing/Installing the Hood .....	21
Greasing the Traction Unit .....	21
Servicing the Air Cleaner .....	22
Servicing the Engine Oil .....	23
Servicing the Battery .....	24
Servicing the Spark Plugs .....	25
Servicing the Hydraulic System .....	25
Replacing the Fuel Filter .....	26
Draining the Fuel Tanks .....	27
Cleaning and Storage .....	27
Troubleshooting .....	28
The Toro Dingo Product Line Warranty .....	32

# Introduction

Thank you for purchasing a Toro product.

All of us at Toro want you to be completely satisfied with your new product, so feel free to contact your local Authorized Service Dealer for help with service, genuine replacement parts, or other information you may require.

Whenever you contact your Authorized Service Dealer or the factory, always know the model and serial numbers of your product. These numbers will help the Service Dealer or Service Representative provide exact information about your specific product. You will find the model and serial number plate at the location shown in Figure 1.

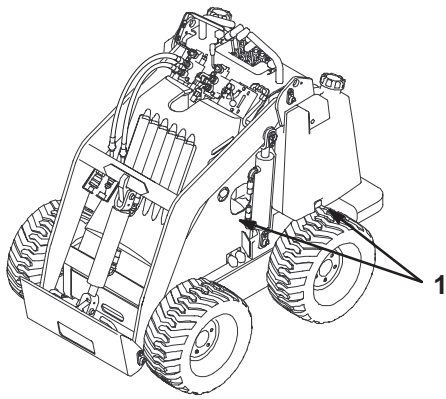

m-5082

**Figure 1**

1. Model and serial number plate (will be in one of two locations)

For your convenience, write the product model and serial numbers in the space below.

<p><b>Model No:</b> _____</p> <p><b>Serial No.</b> _____</p>
--

Read this manual carefully to learn how to operate and maintain your product correctly. Reading this manual will help you and others avoid personal injury and damage to the product. Although we design, produce and market safe, state-of-the-art products, you are responsible for using the product properly and safely. You are also responsible for training persons, who you allow to use the product, about safe operation.

The warning system in this manual identifies potential hazards and has special safety messages that help you and others avoid personal injury, even death. **Danger**, **Warning**, and **Caution** are signal words used to identify the level of hazard. However, regardless of the hazard, be extremely careful.

**Danger** signals an extreme hazard that will cause serious injury or death if the recommended precautions are not followed.

**Warning** signals a hazard that may cause serious injury or death if the recommended precautions are not followed.

**Caution** signals a hazard that may cause minor or moderate injury if the recommended precautions are not followed.



Two other words are also used to highlight information. **Important** calls attention to special mechanical information, and **Note** emphasizes general information worthy of special attention.

# Safety

Improper use or maintenance by the operator or owner can result in injury. To reduce the potential for injury, comply with these safety instructions and always pay attention to the safety alert  symbol, which means CAUTION, WARNING, or DANGER—“personal safety instruction.” Failure to comply with the instruction may result in personal injury or death.

## Safe Operating Practices

This product is capable of amputating hands and feet. Always follow all safety instructions to avoid serious injury or death.

	<h3>Warning</h3>	
<p>Engine exhaust contains carbon monoxide, an odorless, deadly poison that can kill you.</p> <p>Do not run the engine indoors or in an enclosed area.</p>		

## General Operation

- Read, understand, and follow all instructions in the operator’s manual, in the video, and on the traction unit before starting. Also, read all attachment manuals where supplied
- Allow only responsible adults who are familiar with the instructions to operate the traction unit.
- Wear long pants and substantial shoes. Wearing safety glasses, safety shoes, hearing protection, and a hard hat are advisable and may be required by some local ordinances and insurance regulations.
- Ensure that the area is clear of other people before operating the traction unit. Stop the traction unit if anyone enters the area.
- Never carry passengers on attachments or on the traction unit.
- Always look down and behind before and while backing.
- Do not place your feet under the platform.
- Slow down before turning. Sharp turns on any terrain may cause loss of control.
- Never leave a running traction unit unattended. Always lower the loader arms, stop the engine, and remove the key before dismounting.

- Do not exceed the rated operating capacity, as the traction unit may become unstable which may result in loss of control.
- Do not carry a load with the arms raised. Always carry loads close to the ground. Do not step off of the platform with the load raised.
- Do not over-load the attachment and always keep the load level when raising the loader arms. Logs, boards, and other items could roll down the loader arms, injuring you.
- Never jerk the control levers; use a steady motion.
- Keep your hands, feet, hair, and loose clothing away from any moving parts.
- Operate only in daylight or good artificial light.
- Do not operate the traction unit while under the influence of alcohol or drugs.
- Watch for traffic when operating near or crossing roadways.
- Use extra care when loading or unloading the traction unit onto a trailer or truck.
- Do not touch parts which may be hot from operation. Allow them to cool before attempting to maintain, adjust, or service.
- Do not operate the traction unit with any of the covers or guards removed.
- Check for overhead clearances (i.e. branches, doorways, electrical wires) before driving under any objects and do not contact them.
- Before digging, have the area marked for underground utilities, and do not dig in marked areas.
- Raising the loader arms on a slope will affect the stability of the machine. Whenever possible, keep the loader arms in the lowered position when on slopes.
- Removing an attachment on a slope will make the rear of the traction unit heavy. Refer to the Stability Data section, page 11, to determine whether the attachment can be safely removed on the slope.
- Remove obstacles such as rocks, tree limbs, etc. from the work area. Watch for holes, ruts, or bumps, as uneven terrain could overturn the traction unit. Tall grass can hide obstacles.
- Use slow speed on slopes. Before starting the engine, put the pump selector lever in the slow (turtle) position so that you will not have to stop or shift while on the slope.
- Follow the recommendations in the attachment manuals for the use of counterweights to improve stability.
- Use only Toro approved attachments. Attachments can change the stability and the operating characteristics of the traction unit. Warranty may be voided if used with unapproved attachments.
- Keep all movements on slopes slow and gradual. Do not make sudden changes in speed or direction.
- Avoid starting or stopping on a slope. If tires lose traction, proceed slowly, straight down the slope.
- Avoid turning on slopes. If you must turn, turn slowly and keep the heavy end of the traction unit uphill.
- Do not operate near drop-offs, ditches, or embankments. The traction unit could suddenly turn over if a wheel goes over the edge of a cliff or ditch, or if an edge caves in.
- Do not operate on wet grass. Reduced traction could cause sliding.
- Do not park the traction unit on a hillside or slope without lowering the attachment to the ground and chocking the wheels.
- Do not try to stabilize the traction unit by putting your foot on the ground.

## Slope Operation

Slopes are a major factor related to loss-of-control and tip-over accidents which can result in severe injury or death. All slopes require extra caution.

- Do not operate the traction unit on hillsides or slopes exceeding the angles recommended in the Stability Data section, page 11, and those in the attachment operator's manual. See also the slope chart on page 6.
- **Operate up and down slopes with the heavy end of the traction unit uphill.** Weight distribution changes. An empty bucket will make the rear of the traction unit the heavy end, and a full bucket will make the front of the traction unit the heavy end. Most other attachments will make the front of traction unit the heavy end.

## Children

Tragic accidents can occur if the operator is not alert to the presence of children. Children are often attracted to the traction unit and the work activity. Never assume that children will remain where you last saw them.

- Keep children out of the work area and under the watchful care of another responsible adult.
- Be alert and turn the traction unit off if children enter the area.

- Before and while backing, look behind and down for small children.
- Never carry children. They may fall off and be seriously injured or interfere with safe traction unit operation.
- Never allow children to operate the traction unit.
- Use extra care when approaching blind corners, shrubs, trees, the end of a fence, or other objects that may obscure vision.
- Battery gases can explode. Keep cigarettes, sparks and flames away from the battery.
- Keep your body and hands away from pin hole leaks or nozzles that eject high pressure hydraulic fluid. Use cardboard or paper to find hydraulic leaks. Hydraulic fluid escaping under pressure can penetrate skin and cause injury requiring surgery within a few hours by a qualified surgeon or gangrene may result.

## Service

- Stop the engine and disconnect the spark plug wires before performing any service, repairs, maintenance, or adjustments.
- If any maintenance or repair requires the loader arms to be in the raised position, secure the arms in the raised position with the hydraulic cylinder locks included with traction unit.
- Never run a traction unit inside a closed area.
- Keep nuts and bolts tight. Keep equipment in good condition.
- Never tamper with safety devices. Check safety systems for proper operation before each use.
- Keep the traction unit free of grass, leaves, or other debris build-up. Clean up oil or fuel spillage. Allow the traction unit to cool before storing.
- Use extra care when handling gasoline and other fuels. They are flammable and vapors are explosive.
  - Use only an approved container.
  - Never remove the gas cap or add fuel when the engine is running. Allow the engine to cool before refueling. Do not smoke.
  - Never refuel the traction unit indoors.
  - Never store the traction unit or fuel container inside where there is an open flame, such as near a water heater or furnace.
  - Never fill a container while it is inside a vehicle, trunk, pick-up bed, or any surface other than the ground.
  - Keep container nozzle in contact with the tank during filling.
- Stop and inspect the equipment if you strike an object. Make any necessary repairs before restarting.
- Use only genuine replacement parts to ensure that original standards are maintained.
- Battery acid is poisonous and can cause burns. Avoid contact with skin, eyes, and clothing. Protect your face, eyes, and clothing when working with a battery.

# Slope Chart

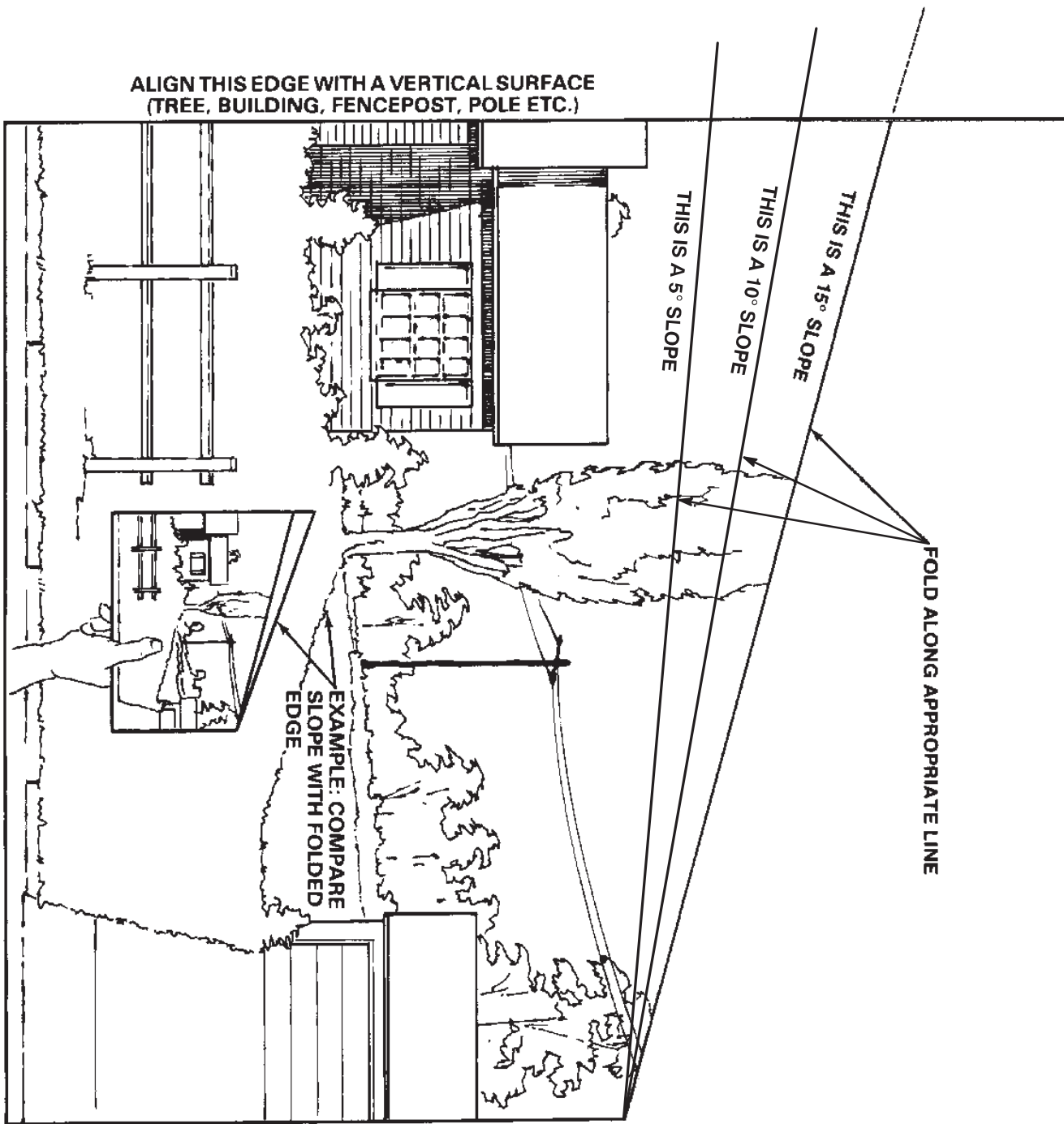



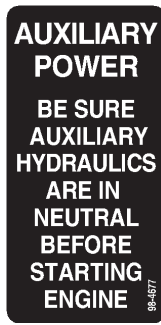

98-4677

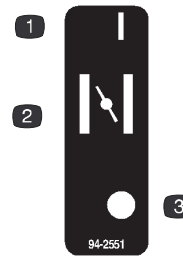

94-2551

- 1. On
- 2. Choke
- 3. Off



100-6141



105-8404

# Assembly

**Note:** Determine the left and right side of the machine from the normal operating position.

## Loose Parts

**Note:** Use the chart below to verify that all parts have been shipped.

DESCRIPTION	QTY.	USE
Traction Unit	1	Install valve lever
Valve Lever	1	
Key	2	Start engine
Hydraulic oil filter	1	Break-in oil change

## Installing the Valve Lever

1. Thread the lever into the speed selector valve (Fig. 2).

**Note:** The lever should be installed with the bend toward the operator.

2. Tighten the jam nut on the lever to lock it in position.

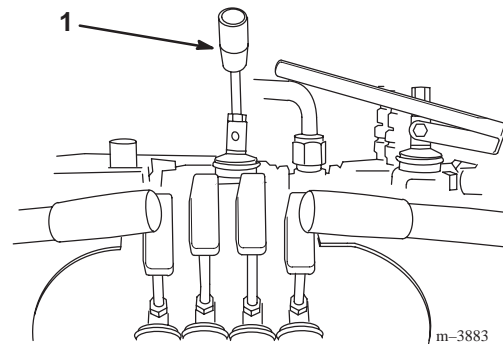

Figure 2

1. Speed selector lever



# Activating the Battery

**Warning**

**Battery posts, terminals, and related accessories contain lead and lead compounds, chemicals known to the State of California to cause cancer and reproductive harm. Wash hands after handling.**

The traction unit is shipped with a dry battery. Purchase bulk electrolyte with 1.260 specific gravity from a local battery supply outlet.

1. Remove the hood; refer to Removing the Hood, page 21.
2. Remove the wing nuts and bar securing the battery (Fig. 3).

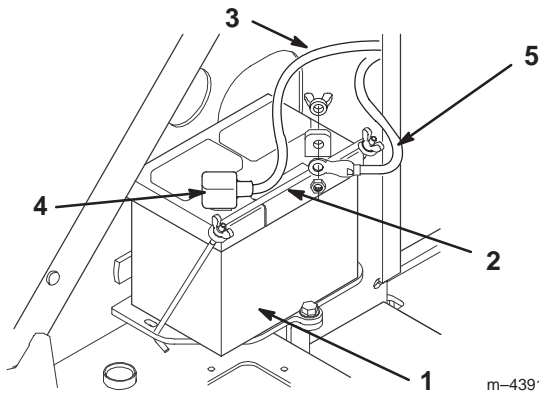

**Figure 3**

- |                   |                   |
|-------------------|-------------------|
| 1. Battery        | 4. Rubber cover   |
| 2. Bar            | 5. Negative cable |
| 3. Positive cable |                   |

3. Gently push the hydraulic hoses aside and lift the battery out of the chassis.

**Danger**

**Battery electrolyte contains sulfuric acid which is a deadly poison and causes severe burns.**

- Do not drink electrolyte and avoid contact with skin, eyes, or clothing. Wear safety glasses to shield your eyes and rubber gloves to protect your hands.
- Fill the battery in an area where clean water is available for flushing the skin.

4. Remove the filler caps from the battery (Fig. 4).

5. Slowly pour electrolyte into each cell until the electrolyte level is up to the lower part of the tube (Fig. 4).

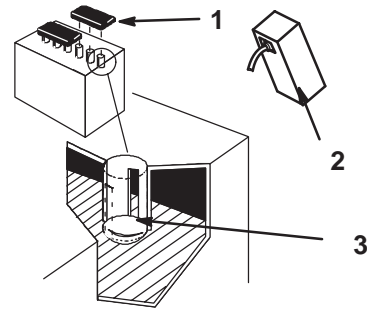

**Figure 4**

- |                |                           |
|----------------|---------------------------|
| 1. Filler caps | 3. Lower part of the tube |
| 2. Electrolyte |                           |

6. Leave the covers off and connect a 3 to 4 amp. battery charger to the battery posts (Fig. 5).

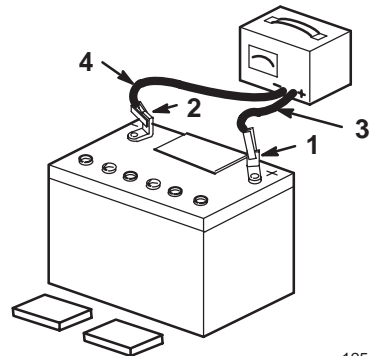

**Figure 5**

- |                  |                           |
|------------------|---------------------------|
| 1. Positive post | 3. Charger red (+) wire   |
| 2. Negative post | 4. Charger black (-) wire |

7. Charge the battery at a rate of 4 amperes or less for 4 hours (12 volts).

**Warning**

**Charging the battery produces gasses that can explode.**

**Never smoke near the battery and keep sparks and flames away from battery.**

8. When the battery is fully charged, disconnect the charger from the electrical outlet and from the negative and positive battery posts (Fig. 5).

9. Slowly pour electrolyte into each cell until the level is once again up to the upper line on the battery case (Fig. 4) and install the covers.
10. Install the battery into the chassis (Fig. 3).
11. Secure the battery with the bar and wing nuts removed previously (Fig. 3).
12. Using the bolt and wing nut supplied with the battery, connect the positive (red) cable to the positive (+) battery post (Fig. 3). Slide the rubber cover over the battery post.
13. Using the bolt and wing nut supplied with the battery, connect the negative (black) cable to the negative (-) battery post (Fig. 3).

**Note:** Ensure that the battery cables do not contact any sharp edges or each other.

14. Install the hood; refer to Installing the Hood, page 21.

## Specifications

Overall width	40.5 in. (103 cm)
Overall length	60.0 in. (152 cm)
Overall height	49.0 in. (125 cm)
Weight	1567 lb. (711 kg)
Rated operating capacity (with 200 lb. operator and std. bucket)	515 lb. (234 kg)
Tipping capacity (with 200 lb. operator and st. bucket)	1030 lb. (467 kg)
Wheelbase	28 in. (71 cm)
Dump height (with std. bucket)	47 in. (120 cm)
Reach—fully raised (with std. bucket)	26.0 in. (66 cm)
Height to hinge pin (std bucket in highest position)	66.0 in. (168 cm)

Specifications and design are subject to change without notice.



## Attachments

Many attachments are available for use with the traction unit. These attachments allow you to perform many different functions with the traction unit such as hauling materials, digging holes, grading, and more. Contact your Toro dealer for a list of all approved attachments and accessories.

**Important** Use only Toro approved attachments.

# Stability Data

The following table lists the maximum slope recommended for the traction unit in the positions listed in the table. Slopes over the listed degree may cause the traction unit to become unstable. The data in the table assumes that the loader arms are fully lowered and that the factory installed tires are on the traction unit, inflated to the recommended pressure; raised arms and other tire types or pressure may affect the stability.

Configuration	Maximum Recommended Slope when Operating with:		
	Front Uphill 	Rear Uphill 	Side Uphill 
Traction unit without attachment	10°	20°	18°
Traction unit with counterweight, without attachment	8°	20°	19°
Traction unit with an attachment rated with one of the following stability ratings for each slope position:*			
<b>A</b>	25°	25°	20°
<b>B</b>	20°	20°	17°
<b>C</b>	15°	15°	13°
<b>D</b>	10°	10°	9°
<b>E</b>	5°	5°	5°

\* In each attachment manual is a set of three stability ratings, one for each hill position. To determine the maximum slope you can traverse with the attachment installed, find the degree of slope that corresponds to the stabilities ratings of the attachment. Unless otherwise specified in the attachment manual, assume that the listed ratings are for use without the counterweight.

Example: If the attachment installed on the traction unit has a Front Uphill rating of B, a Rear Uphill rating of D, and a Side Uphill rating of C, then you could drive forward up a 20° slope, rearward up a 10° slope, or sideways on a 13° slope, as listed in the above table.

# Before Operating

Before operating, check the fuel and oil level, remove debris from the traction unit, and check the tire pressure. Also, ensure that the area is clear of people and debris. You should also know and have marked the locations of all utility lines.

## Adding Fuel



### Danger



In certain conditions, gasoline is extremely flammable and highly explosive. A fire or explosion from gasoline can burn you and others and can damage property.

- Fill the fuel tank outdoors, in an open area, when the engine is cold. Wipe up any gasoline that spills.
- Do not fill the fuel tank completely full. Add gasoline to the fuel tank until the level is 1/4 to 1/2 in. (6 to 13 mm) below the bottom of the filler neck. This empty space in the tank allows gasoline to expand.
- Never smoke when handling gasoline, and stay away from an open flame or where gasoline fumes may be ignited by a spark.
- Store gasoline in an approved container and keep it out of the reach of children. Never buy more than a 30-day supply of gasoline.
- Always place gasoline containers on the ground away from your vehicle before filling.
- Do not fill gasoline containers inside a vehicle or on a truck or trailer bed because interior carpets or plastic truck bed liners may insulate the container and slow the loss of any static charge.
- When practical, remove gas-powered equipment from the truck or trailer and refuel the equipment with its wheels on the ground.
- If this is not possible, then refuel such equipment on a truck or trailer from a portable container, rather than from a gasoline dispenser nozzle.
- If a gasoline dispenser nozzle must be used, keep the nozzle in contact with the rim of the fuel tank or container opening at all times until fueling is complete.

Use unleaded regular gasoline (87 pump octane minimum). Leaded regular gasoline may be used if unleaded regular is not available.

**Important** Never use methanol, gasoline containing methanol, or gasohol containing more than 10% ethanol because the fuel system could be damaged. Do not mix oil with gasoline.

**Important** Never use fuel additives containing methanol or ethanol.

**Note:** The two fuel tanks will run empty equally; however, you must fill them separately because filling one will not fill the other.

## Filling the Fuel Tanks

1. Park the traction unit on a level surface, lower the loader arms, and stop the engine.
2. Remove the key and allow the engine to cool.
3. Clean around the fuel tank caps and remove them.
4. Use a funnel and add unleaded regular gasoline to each fuel tank, until the level is 1/4 to 1/2 in. (6 mm to 13 mm) below the bottom of each filler neck.

**Important** This space in the tank allows gasoline to expand. Do not fill the fuel tank completely full.

5. Install the fuel tank caps securely. Wipe up any gasoline that may have spilled.

## Using Stabilizer/Conditioner

Use a fuel stabilizer/conditioner in the machine to provide the following benefits:

- Keeps gasoline fresh during storage of 90 days or less. For longer storage, drain the fuel tank.
- Cleans the engine while it runs
- Eliminates gum-like varnish buildup in the fuel system, which causes hard starting

**Important** Do not use fuel additives containing methanol or ethanol.

Add the correct amount of gas stabilizer/conditioner to the gas.

**Note:** A fuel stabilizer/conditioner is most effective when mixed with fresh gasoline. To minimize the chance of varnish deposits in the fuel system, use fuel stabilizer at all times.

## Checking the Oil Level

1. Park the traction unit on a level surface, lower the loader arms, and stop the engine.
2. Remove the key and allow the engine to cool.
3. Clean around the oil dipstick (Fig. 6).
4. Pull out the dipstick and wipe the metal end clean (Fig. 6).
5. Slide the dipstick fully into the dipstick tube (Fig. 6).
6. Pull the dipstick out and look at the metal end.
7. If the oil level is low, clean around the oil filler cap and remove the cap (Fig. 6).
8. Slowly pour only enough oil into the valve cover to raise the level to the F (full) mark.

**Important** Do not overfill the crankcase with oil because the engine may be damaged.

9. Replace the filler cap and dipstick.

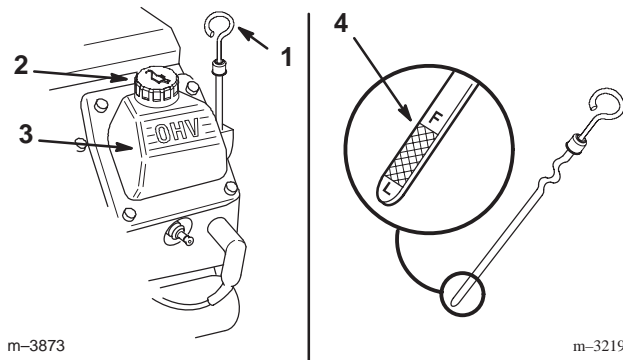

**Figure 6**

1. Oil dipstick
2. Filler cap
3. Valve cover
4. Metal end

## Removing Debris from the Traction Unit

**Important** Operating the engine with a blocked grass screen, dirty or plugged cooling fins, and/or cooling shrouds removed, will result in engine damage from overheating.

1. Park the traction unit on a level surface, raise the loader arms, and install the cylinder locks; refer to Using the Cylinder Locks, page 18.
2. Stop the engine and remove the key.
3. Remove the hood; refer to Removing the Hood, page 21.
4. Clean any debris from the grill before each use and/or during use, if required.
5. Wipe away debris from the air cleaner before each use and/or during use, if required.
6. Clean any debris build-up on the engine with a brush or blower before each use.

**Important** It is preferable to blow dirt out, rather than washing it out. If water is used, keep it away from electrical items and hydraulic valves. Do not use a high-pressure washer. High-pressure washing can damage the electrical system and hydraulic valves or deplete grease.

7. Install the hood; refer to Installing the Hood, page 21.
8. Remove and store the cylinder locks (refer to Using the Cylinder Locks, page 18), and lower the loader arms.

## Checking the Hydraulic Fluid

Check the hydraulic fluid level before the engine is first started and after every 25 operating hours.

**Hydraulic Tank Capacity:** 17.25 gal. (67 l)

**Hydraulic Fluid:** 10W-30 detergent, diesel engine oil (API service CH-4 or higher).

1. Remove the attachment, if one is installed; refer to Removing an Attachment, page 20.
2. Park the traction unit on a level surface, raise the loader arms, and install the cylinder locks; refer to Using the Cylinder Locks, page 18.
3. Stop the engine and remove the key.
4. Remove the hood; refer to Removing the Hood, page 21.
5. Clean the area around the filler neck of the hydraulic tank (Fig. 7).
6. Remove the cap from the filler neck and check the fluid level on the dipstick (Fig. 7).

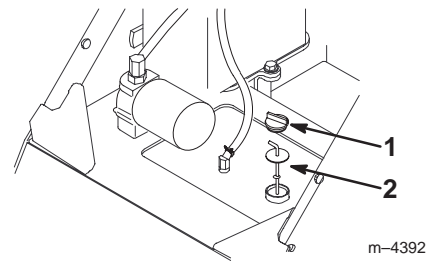

**Figure 7**

1. Filler neck cap
2. Dipstick

7. If the level is low, add enough fluid to raise it to the proper level.
8. Install the cap on the filler neck.
9. Install the hood; refer to Installing the Hood, page 21.
10. Remove and store the cylinder locks (refer to Using the Cylinder Locks, page 18) and lower the loader arms.

## Tire pressure

Maintain the air pressure in the tires as specified. Check the tires when they are cold to get the most accurate reading.

Pressure: 15-20 psi.

**Note:** Use a lower tire pressure (15 psi.) when operating in sandy soil conditions to provide better traction in the loose soil.

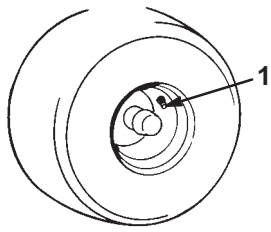

m-1872

**Figure 8**

1. Valve stem

# Operation

**Note:** Determine the left and right side of the machine from the normal operating position.

## Traction Unit Overview

Figure 9 contains a front and back view of the traction unit. Familiarize yourself with all of the traction unit components listed in Figure 9.

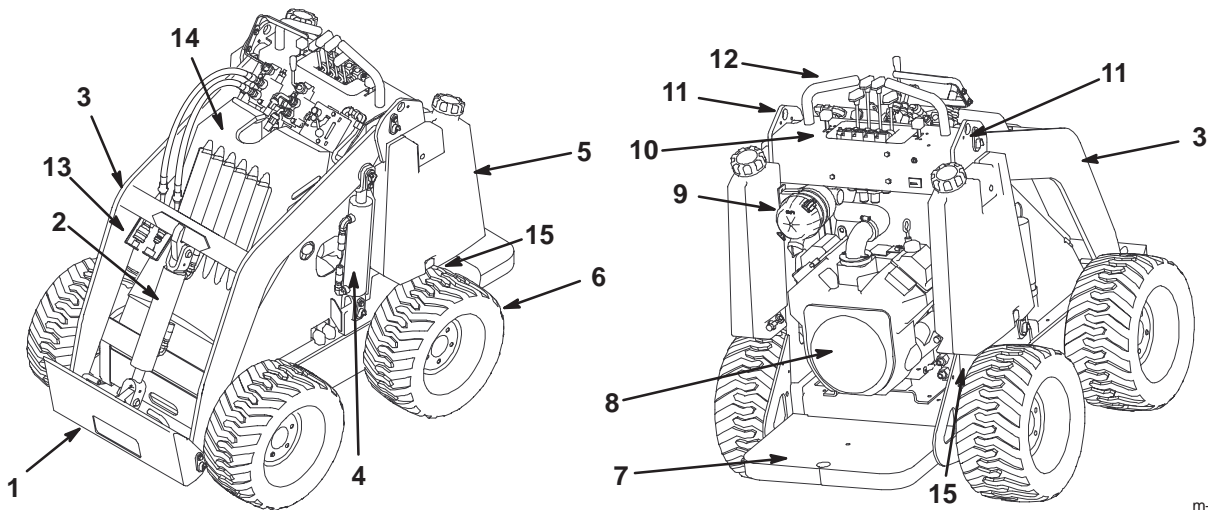

m-4393/4389

**Figure 9**

- |                  |                      |                   |                                  |
|------------------|----------------------|-------------------|----------------------------------|
| 1. Mount plate   | 5. Fuel tank         | 9. Air filter     | 13. Auxiliary hydraulic couplers |
| 2. Tilt cylinder | 6. Wheel             | 10. Control panel | 14. Hood                         |
| 3. Loader arms   | 7. Operator platform | 11. Lift points   | 15. Tow valve                    |
| 4. Lift cylinder | 8. Engine            | 12. Handle        |                                  |



## Caution



**You could fall off of the platform and be seriously injured during operation.**

**Do not move the control levers unless you are standing with both feet on the platform and your hands are holding the handles.**

## Controls

Become familiar with all the controls (Fig. 10) before you start the engine and operate the traction unit.

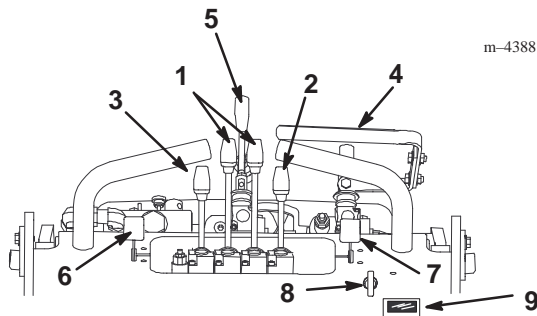

**Figure 10**

- |                               |                          |
|-------------------------------|--------------------------|
| 1. Traction control levers    | 6. Throttle lever        |
| 2. Attachment tilt lever      | 7. Choke lever           |
| 3. Loader arm lever           | 8. Key switch            |
| 4. Auxiliary hydraulics lever | 9. Hour meter/tachometer |
| 5. Speed selector lever       |                          |

### Key Switch

The key switch, used to start and stop the engine, has three positions: off, run, and start.

To start the engine, rotate the key to the start position. Release the key when engine starts and it will move automatically to the run position.

To stop the engine, rotate the key to the off position.

### Throttle Lever

Move the control forward to increase the engine speed and rearward to decrease speed.

### Choke Lever

Before starting a cold engine, move the choke lever fully forward. After the engine starts, regulate the choke to keep the engine running smoothly. As soon as possible, move the choke lever rearward as far as possible. A warm engine requires little or no choking.

### Traction Control Levers

To move forward, move the traction control levers forward. To move rearward, move the traction control levers rearward.

To go straight, move both traction control levers equally.

To turn, move the lever located on the side you want to turn back toward the neutral position while keeping the other lever engaged.

The farther you move the traction control levers in either direction, the faster the traction unit will move in that direction.

To slow or stop, move the traction control levers to neutral.

### Attachment Tilt Lever

To tilt the attachment forward, slowly push the attachment tilt lever forward.

To tilt the attachment rearward, slowly pull the attachment tilt lever rearward.

### Loader Arm Lever

To lower the loader arms, slowly push the loader arm lever forward.

To raise the loader arms, slowly pull the loader arm lever rearward.

### Auxiliary Hydraulics Lever

To operate a hydraulic attachment in forward direction, slowly pull the auxiliary hydraulics lever rearward.

To operate a hydraulic attachment in reverse direction, slowly push the auxiliary hydraulics lever forward. This is also called the detent position because it does not require operator presence.

### Speed Selector Lever

Move the speed selector lever to the fast (rabbit) position to set the traction drive, loader arms, and attachment tilt to high speed and the auxiliary hydraulics to low speed.

Move the speed selector lever to the slow (turtle) position to set the auxiliary hydraulics to high speed and the traction drive, loader arms, and attachment tilt to low speed.

Warning

**If you move the speed selector lever while the traction unit is in motion, the traction unit will either stop suddenly or accelerate quickly. If you operate the traction unit with the speed selector lever in an intermediate position, the traction unit will operate erratically and may be damaged. You could lose control of the traction unit and injure bystanders or yourself.**

- **Do not move the speed selector lever when the traction unit is in motion.**
- **Do not operate the traction unit when the speed selector is in any intermediate position (i.e., any position other than fully forward or fully rearward).**

## Hour Meter/Tachometer

When the engine is off, the hour meter/tachometer displays the number of hours of operation that have been logged on the traction unit. When the engine is running, it displays the speed of the engine in revolutions per minute (rpm).

After 50 hours and then every 100 hours thereafter (that is at 150, 250, 350, etc.) the screen displays CHG OIL to remind you to change the oil. After every 100 hours, the screen displays SVC to remind you to perform the other maintenance procedures based on a 100, 200, or 400 hour schedule. These reminders come on starting three hours prior to the service interval time and flash at regular intervals for six hours.

## Flow Divider Control

The traction unit hydraulics (i.e., the traction drive, loader arms, and attachment tilt) work on a separate hydraulic circuit from the auxiliary hydraulics for powering attachments; however, the two systems share the same hydraulic pumps. Using the flow divider control (Fig. 11), you can vary the speed of the traction unit hydraulics by diverting hydraulic flow to the auxiliary hydraulics circuit. The flow divider allows you to divide the flow of fluid in varying degrees to slow the traction unit. Thus, the more hydraulic flow you divert to the auxiliary hydraulics, the slower the traction unit will move.

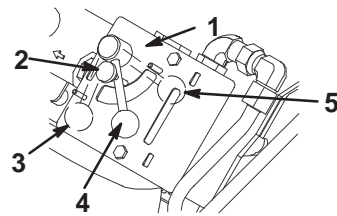

**Figure 11**

- |                         |                              |
|-------------------------|------------------------------|
| 1. Flow divider control | 4. 10 to 11 o'clock position |
| 2. Knob                 | 5. 9 o'clock position        |
| 3. 12 o'clock position  |                              |

- Move the flow divider control to the twelve o'clock position to provide maximum speed to the traction unit.

Use this setting for fast operation of the traction unit.

- Move the flow divider control between the twelve o'clock and nine o'clock positions to slow the traction unit and fine tune the speed.

Use a setting in this range with attachments with hydraulics where you need to both run the attachment and move the traction unit hydraulics, such as the auger, boring unit, hydraulic blade, and tiller.

- Move the control to the nine o'clock position to transfer all hydraulic flow to the auxiliary hydraulics of the attachment.

In this setting, the traction unit will not move. Use this setting with hydraulic attachments that do not require the traction unit to move. There are currently no attachments that require the nine o'clock position; however, the trencher does work best if you set it close to nine o'clock so that the traction unit will creep slowly when trenching.

**Note:** You can fix the flow divider control in place by turning the knob on the control clockwise until it contacts the dial (Fig. 11).

## Starting and Stopping the Engine

### Starting the Engine

1. Stand on the platform.
2. Move the auxiliary hydraulics valve lever to neutral.
3. Move the throttle lever midway between slow (turtle) and fast (rabbit) positions.
4. Move the choke lever fully forward before starting a cold engine.

**Note:** A warm or hot engine may not require choking.

5. Turn the ignition key to the start position. When the engines starts, release the key.



**Important** Do not engage the starter for more than 10 seconds at a time. If the engine fails to start, allow a 30 second cool-down period between attempts. Failure to follow these instructions can burn out the starter motor.

6. After the engine starts, gradually move the choke rearward. If the engine stalls or hesitates, move the choke forward again until the engine warms up.

7. Move the throttle lever to the desired setting.

**Important** If you run the engine at high speeds when the hydraulic system is cold (i.e., when the ambient air temperature is around freezing or lower), hydraulic system damage could occur. When starting the engine in cold conditions, allow the engine to run in the middle throttle position for 2 to 5 minutes before moving the throttle to fast (rabbit).

## Stopping the Engine

1. Move the throttle lever to the slow (turtle) position.
2. Lower the loader arms to the ground.
3. Turn the ignition key off.

**Note:** If the engine has been working hard or is hot, let it idle for a minute before turning the ignition key off. This helps cool the engine before it is stopped. In an emergency, the engine may be stopped immediately.

## Driving Forward or Backward

The throttle control regulates the engine speed as measured in rpm (revolutions per minute). Place the throttle lever in the fast (rabbit) position for best performance.

**Note:** You can adjust the throttle position to operate at slower speeds.

To drive the traction unit, complete the following actions as necessary:

- To move forward, move the traction control levers forward.
- To move rearward, move the traction control levers rearward.
- To go straight, move both traction control levers equally.
- To turn, move the lever located on the side you want to turn toward the neutral position while keeping the other lever engaged.
- To slow or stop, move the traction control levers to neutral.

**Note:** The farther you move the traction control levers in either direction, the faster the traction unit will move in that direction.

## Stopping the Traction Unit

To stop the traction unit, move the traction control levers to neutral and the throttle lever to slow (turtle), lower loader arms to the ground, and turn the ignition key off to stop the engine. Remove the key.

**Caution**

**A child or untrained bystander could attempt to operate the traction unit and be injured.**

**Remove the key from the switch when leaving the traction unit, even if just for a few seconds.**

## Moving a Non-functioning Traction Unit

**Important** Do not tow or pull the traction unit without first opening the tow valves, or the hydraulic system will be damaged.

1. Stop the engine.
2. Remove the plug covering each tow valve (Fig. 12).

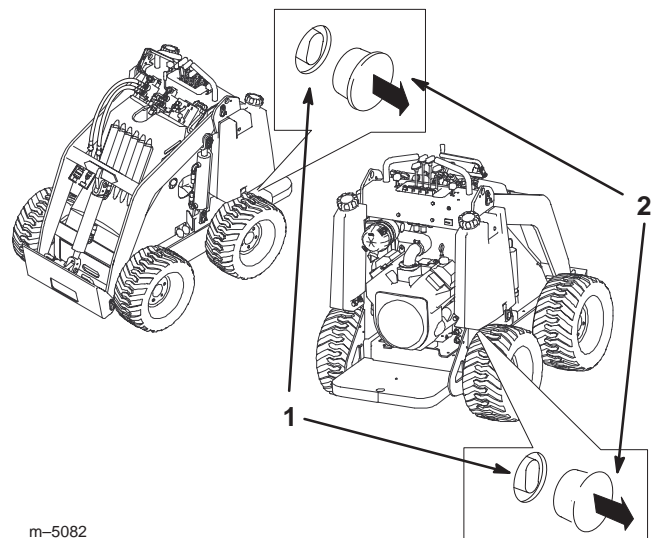

**Figure 12**

1. Tow valve

2. Plug

3. Loosen the jam nut on each tow valve (Fig. 12).
4. Turn the valves counter-clockwise one turn with a hex wrench to open them.

5. Tow the traction unit as required.

**Important** Do not exceed 3 mph when towing.

6. When the traction unit has been repaired, close the tow valves and tighten the jam nuts.

**Important** Do not overtighten the tow valves.

7. Replace the plugs.

## Using the Cylinder Locks



### Warning



The loader arms may lower when in the raised position crushing anyone under them.

Install the cylinder locks before performing maintenance that requires raised loader arms.

## Installing the Cylinder Locks

1. Start the engine.
2. Raise the loader arms to the fully raised position.
3. Stop the engine.
4. Position a loader arm cylinder lock over each lift cylinder rod (Fig. 13).
5. Secure each loader arm cylinder lock with a clevis pin and cotter pin (Fig. 13).

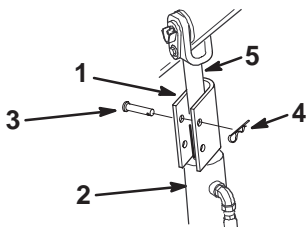

m-4398

Figure 13

1. Cylinder lock
2. Lift cylinder
3. Hairpin cotter
4. Clevis pin
5. Lift cylinder rod

6. With the engine off, lower the loader arms.

## Removing/Storing the Cylinder Locks

1. Start the engine.

2. Raise the loader arms to the fully raised position.

3. Stop the engine.

4. Remove the clevis pin and cotter pin securing each cylinder lock.

5. Remove the cylinder locks.

6. Lower the loader arms.

7. Install the cylinder locks over the hydraulic hoses and secure them with the clevis pins and cotter pins (Fig. 14).

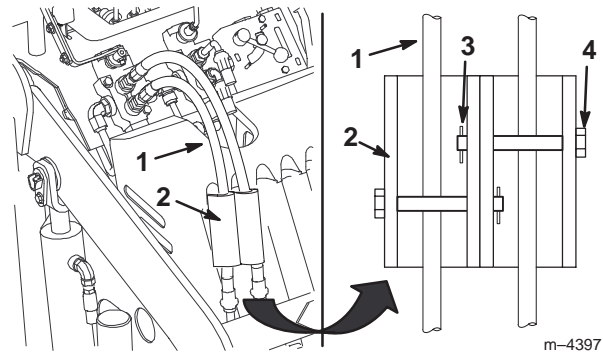

m-4397

Figure 14

1. Hydraulic hoses
2. Cylinder locks
3. Hairpin cotter
4. Clevis pin

## Installing and Removing Attachments

### Connecting an Attachment

**Important** Use only Toro-approved attachments. Attachments can change the stability and the operating characteristics of the traction unit. The warranty of the traction unit may be voided if used with unapproved attachments.

**Important** Before installing the attachment, ensure that the mount plates are free of any dirt or debris and that the pins rotate freely. If the pins do not rotate freely, grease them; refer to Greasing the Traction Unit, page 22.

1. Position the attachment on a level surface with enough space behind it to accommodate the traction unit.
2. Start the engine.
3. Tilt the attachment mount plate forward.
4. Position mount plate into the upper lip of the attachment receiver plate (Fig. 15).

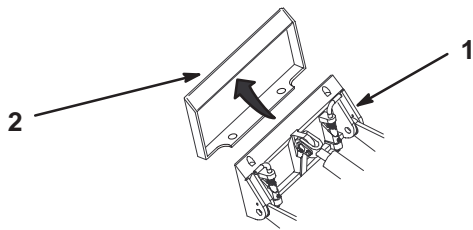

m-4055

**Figure 15**

1. Mount plate
2. Receiver plate

5. Raise the loader arms while tilting back the mount plate at the same time.

**Important** The attachment should be raised enough to clear the ground, and the mount plate should be tilted all the way back.

6. Stop the engine.
7. Engage the quick attach pins, ensuring that they are fully seated in the mount plate (Fig. 16).

**Important** If the pins do not rotate to the engaged position, the mount plate is not fully aligned with the holes in the attachment receiver plate. Check the receiver plate and clean it if necessary.

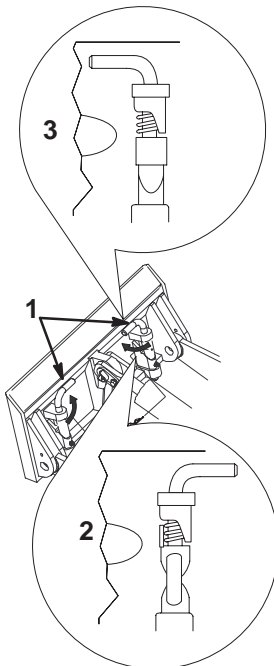

m-5919

**Figure 16**

1. Quick attach pins (shown in engaged position)
2. Disengaged position
3. Engaged position

⚠
Warning
⚠

If you do not fully seat the quick attach pins through the attachment mount plate, the attachment could fall off of the traction unit, crushing you or bystanders.

Ensure that your quick attach pins are fully seated in the attachment mount plate.

## Connecting the Hydraulic Hoses

If the attachment requires hydraulics for operation, connect the hydraulic hoses as follows:

1. Stop the engine.
2. Move the auxiliary hydraulics lever forward, backward, and back to neutral to relieve pressure at the hydraulic couplers.
3. Push the auxiliary hydraulics lever forward into the detent position.
4. Remove the protective covers from the hydraulic couplers on the traction unit.
5. Ensure that all foreign matter is cleaned from the hydraulic connectors.
6. Push the attachment male connector into the female connector on the traction unit.

**Note:** When you connect the attachment male connector first, you will relieve any pressure build up in the attachment.

⚠
Warning
⚠

Hydraulic fluid escaping under pressure can penetrate skin and cause injury. Fluid injected into the skin must be surgically removed within a few hours by a doctor familiar with this form of injury or gangrene may result.

- Keep your body and hands away from pin hole leaks or nozzles that eject high pressure hydraulic fluid.
- Use cardboard or paper to find hydraulic leaks, never use your hands.



## Caution



**Hydraulic couplers, hydraulic lines/valves, and hydraulic fluid may be hot. If you contact hot components you may be burned.**

- **Wear gloves when operating the hydraulic couplers.**
- **Allow the traction unit to cool before touching hydraulic components.**
- **Do not touch hydraulic fluid spills.**

7. Push the attachment female connector into the male connector on the traction unit.
8. Confirm that the connection is secure by pulling on the hoses.
9. Move the auxiliary hydraulics lever to neutral.

### Removing an Attachment

1. Lower the attachment to the ground
2. Stop the engine.
3. Disengage the quick attach pins by turning them to the outside.
4. If the attachment uses hydraulics, move the auxiliary hydraulics lever forward, backward, and back to neutral to relieve pressure at the hydraulic couplers.

## Maintenance

**Note:** Determine the left and right side of the machine from the normal operating position.

### Recommended Maintenance Schedule

Maintenance Service Interval	Maintenance Procedure
8 hours	<ul style="list-style-type: none"> <li>• Grease the traction unit</li> <li>• Check engine oil level</li> <li>• Check for loose fasteners</li> <li>• Check tire pressure (20 psi.)</li> </ul>
25 hours	<ul style="list-style-type: none"> <li>• Clean primary air filter<sup>1</sup></li> <li>• Check hydraulic oil level</li> <li>• Inspect hydraulic lines for leaks</li> </ul>
100 hours	<ul style="list-style-type: none"> <li>• Change engine oil<sup>1, 2</sup></li> <li>• Check battery electrolyte level</li> <li>• Check wheel lug nut torque (50 ft.-lb)<sup>3</sup></li> <li>• Check battery cable connections</li> </ul>

5. If the attachment uses hydraulics, slide the collar back on the hydraulic couplers and disconnect them.

**Important** Connect the attachment hoses together to prevent hydraulic system contamination during storage.

6. Install the protective covers onto the hydraulic couplers on the traction unit.
7. Start the engine, tilt the mount plate forward, and back the traction unit away from the attachment.

### Securing the Traction Unit for Transport

When transporting the traction unit on a trailer, always use the following procedure:

**Important** Do not operate or drive the traction unit on roadways.

1. Lower the loader arms.
2. Stop the engine.
3. Secure the traction unit to the trailer with chains or straps using the operator platform support openings to secure the rear of the traction unit and the loader arms/mount plate to secure the front of the traction unit.

Maintenance Service Interval	Maintenance Procedure
200 hours	<ul style="list-style-type: none"> <li>• Change engine oil filter (every other oil change)<sup>1, 4</sup></li> <li>• Check engine speed (1400 rpm idle and 3600 full throttle, ± 75)</li> <li>• Check spark plugs</li> </ul>
400 hours	<ul style="list-style-type: none"> <li>• Change hydraulic filter<sup>1, 3, 5</sup></li> <li>• Inspect fuel lines for leaks</li> </ul>
Yearly/Storage	<ul style="list-style-type: none"> <li>• Change hydraulic oil<sup>1, 6</sup></li> <li>• Replace primary and secondary air filters<sup>1</sup></li> <li>• Replace the fuel filter<sup>1</sup></li> <li>• Touch up chipped paint</li> </ul>

<sup>1</sup>More often in dusty, dirty conditions.

<sup>2</sup>Change oil after the first 50 operating hours.

<sup>3</sup>Change the hydraulic filter and torque the lug nuts after the first 8-10 operating hours

<sup>4</sup>For severe duty or rental applications, change every 100 operating hours.

<sup>5</sup>For severe duty or rental applications, change every 200 operating hours.

<sup>6</sup>For severe duty or rental applications, change every 400 operating hours.

**Important** Refer to your engine operator's manual for additional maintenance procedures.

**Note:** After 50 hours and then every 100 hours thereafter (that is at 150, 250, 350, etc.) the screen displays CHG OIL to remind you to change the oil. After every 100 hours, the screen displays SVC to remind you to perform the other maintenance procedures based on a 100, 200, or 400 hour schedule. These reminders come on starting three hours prior to the service interval time and flash at regular intervals for six hours.

⚠ **Caution** ⚠

**If you leave the key in the ignition switch, someone could accidentally start the engine and seriously injure you or other bystanders.**

**Remove the key from the ignition and disconnect the wires from the spark plugs before you do any maintenance. Set the wire aside so that it does not accidentally contact the spark plug.**

## Removing/Installing the Hood

### Removing the Hood

Before performing many maintenance procedures, you will need to remove the hood.

1. Raise the loader arms and install the cylinder locks; refer to Using the Cylinder Locks, page 18.

**Note:** In the case that you need to remove the hood without raising the loader arms, be very careful not to damage the hood or hydraulic hoses as you maneuver the hood out from under the arms.

2. Stop the engine and remove the key.
3. Release the four locking tabs (Fig. 17).

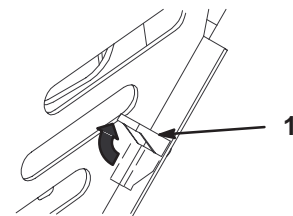

m-4395

**Figure 17**

1. Locking tabs

4. Pull the hood off of the traction unit.

### Installing the Hood

1. Position the hood over the traction unit frame with the posts on the hood fitting into the holes on the frame (Fig. 17).

- Secure the hood by pushing the locking tabs forward and down (Fig. 17).

## Greasing the Traction Unit

Grease all pivot joints every 8 operating hours and immediately after every washing.

Grease Type: General-purpose grease.

- Lower the loader arms and stop the engine. Remove the key.
- Clean the grease fittings with a rag.
- Connect a grease gun to each fitting (Fig. 18 and 19).

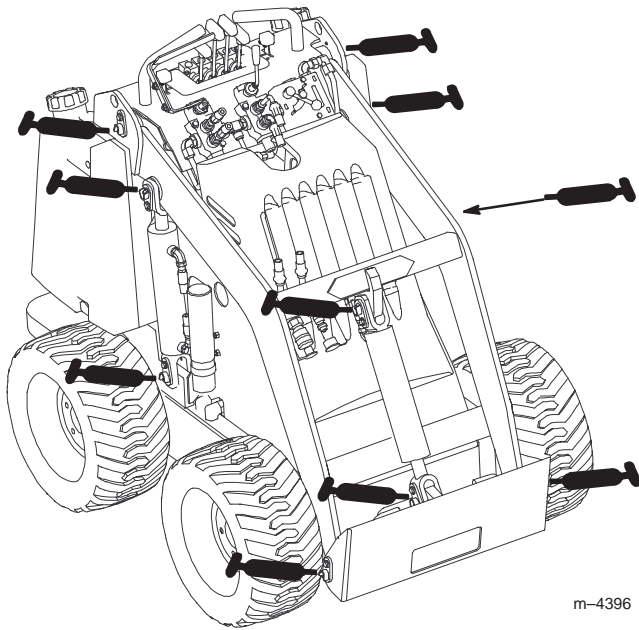

Figure 18

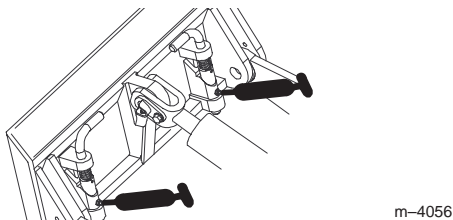

Figure 19

- Pump grease into the fittings until grease begins to ooze out of the bearings (approximately 3 pumps).
- Wipe up any excess grease.

## Servicing the Air Cleaner

Clean the primary filter every 25 operating hours. Replace the primary and secondary filter yearly.

**Note:** Service the air cleaner more frequently if operating conditions are extremely dusty or sandy.

### Removing the Filter

- Lower the loader arms and stop the engine. Remove the key.
- Release the latches on the air cleaner and pull the air cleaner cover off of the air cleaner body (Fig. 20).
- Clean the inside of the air cleaner cover with compressed air.
- Gently slide the primary filter out of the air cleaner body (Fig. 20). Avoid knocking the filter into the side of the body. Do not remove the safety filter, unless you intend to replace it as well.
- Inspect the primary filter for damage by looking into the filter while shining a bright light on the outside of the filter. Holes in the filter will appear as bright spots. If the filter is damaged, discard it, otherwise clean it.

**Important** Never attempt to clean the safety filter. If the safety filter is dirty, then the primary filter is damaged and you should replace both filters.

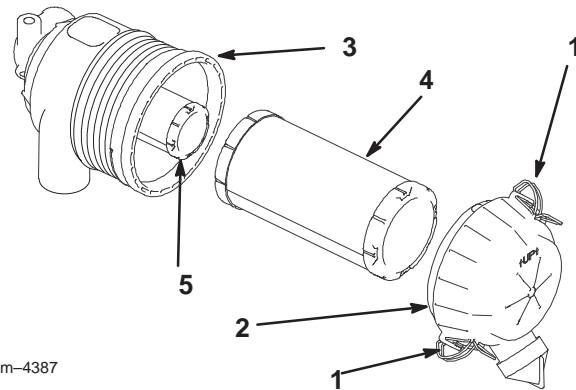

Figure 20

- |                      |                   |
|----------------------|-------------------|
| 1. Latches           | 4. Primary filter |
| 2. Air cleaner cover | 5. Safety filter  |
| 3. Air filter body   |                   |

### Cleaning the Primary Filter

Blow compressed air from the inside to the outside of the primary filter.

**Important** Do not exceed 100 psi. and keep the hose at least 2 in. from the filter.



1. Drain the oil from the engine; refer to Changing the Oil, page 23.
2. Remove the old filter and wipe the filter adapter (Fig. 22) gasket surface.
3. Pour new oil of the proper type in through the center hole of the filter. Stop pouring when the oil reaches the bottom of the threads.
4. Allow a minute or two for the oil to be absorbed by filter material, then pour off the excess oil.
5. Apply a thin coat of new oil to the rubber gasket on the replacement filter (Fig. 22).

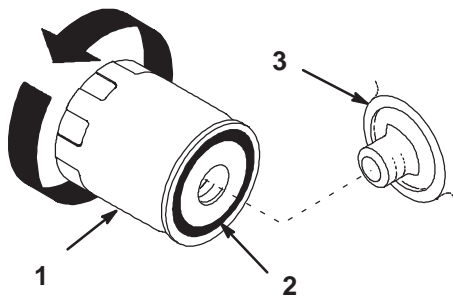

**Figure 22**

1. Oil filter
2. Gasket
3. Adapter

m-1256

6. Install the replacement oil filter to the filter adapter. Turn the oil filter clockwise until the rubber gasket contacts the filter adapter, then tighten the filter an additional 1/2 turn (Fig. 22).
7. Fill the crankcase with the proper type of new oil; refer to Changing the Oil, page 23.

## Servicing the Battery



### Warning



**Battery posts, terminals, and related accessories contain lead and lead compounds, chemicals known to the State of California to cause cancer and reproductive harm. Wash hands after handling.**

Check the electrolyte level in the battery every 100 hours. Always keep the battery clean and fully charged. Use a paper towel to clean the battery case. If the battery terminals are corroded, clean them with a solution of four

parts water and one part baking soda. Apply a light coating of grease to the battery terminals to reduce corrosion.

Voltage: 12 v, 380 Cold Cranking Amps

## Checking the Electrolyte Level

1. Open covers to see into the cells. The electrolyte must be up to the lower part of the tube (Fig. 23).

**Important** Do not allow the electrolyte to get below the plates. (Fig. 23).

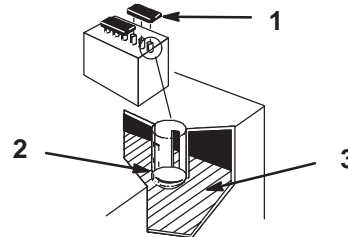

1262

**Figure 23**

1. Filler caps
2. Lower part of tube
3. Plates

2. If the electrolyte is low, add the required amount of distilled water; refer to Adding Water to the Battery, below.

## Adding Water to the Battery

The best time to add distilled water to the battery is just before you operate the traction unit. This lets the water mix thoroughly with the electrolyte solution.

1. Clean the top of the battery with a paper towel.
2. Lift off the filler caps (Fig. 23).
3. Slowly pour distilled water into each battery cell until the level is up to the lower part of the tube (Fig. 23).

**Important** Do not overfill the battery because electrolyte (sulfuric acid) can cause severe corrosion and damage to the chassis.

4. Press the filler caps onto the battery.

## Charging the Battery

**Important** Always keep the battery fully charged (1.260 specific gravity). This is especially important to prevent battery damage when the temperature is below 32°F (0°C).

1. Check the electrolyte level; refer to Checking Electrolyte Level, page 24.



- Remove the filler caps from the battery and connect a 3 to 4 amp. battery charger to the battery posts. Charge the battery at a rate of 4 amperes or less for 4 hours (12 volts). Do not overcharge the battery.
- Install the filler caps after the battery is fully charged.

! **Warning** !

**Charging the battery produces gasses that can explode.**

**Never smoke near the battery and keep sparks and flames away from battery.**

## Servicing the Spark Plugs

Check the spark plugs after every 200 operating hours. Ensure that the air gap between the center and side electrodes is correct before installing each spark plug. Use a spark plug wrench for removing and installing the spark plugs and a gapping tool/feeler gauge to check and adjust the air gap. Install new spark plugs if necessary.

Type: Champion Premium Gold 2071 or Champion RC12YC (or equivalent) Air Gap: 0.030 in. (0.76 mm)

### Removing the Spark Plugs

- Lower the loader arms and stop the engine. Remove the key.
- Pull the wires off of the spark plugs (Fig. 24).
- Clean around the spark plugs.
- Remove the spark plugs and metal washers.

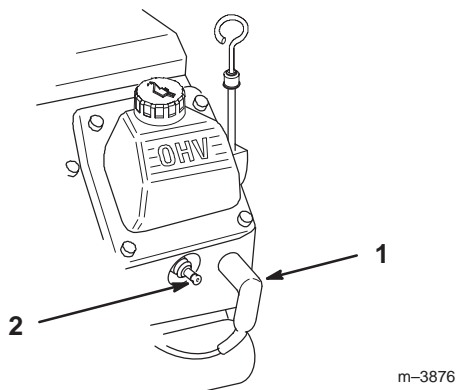

**Figure 24**

- Spark plug wire
- Spark plug

## Checking the Spark Plugs

- Look at the center of the spark plugs (Fig. 25). If you see light brown or gray on the insulator, the engine is operating properly. A black coating on the insulator usually means the air cleaner is dirty.

**Important** Never clean the spark plugs. Always replace the spark plugs when they have a black coating, worn electrodes, an oily film, or cracks.

- Check the gap between the center and side electrodes (Fig. 25).
- Bend the side electrode (Fig. 25) if the gap is not correct.

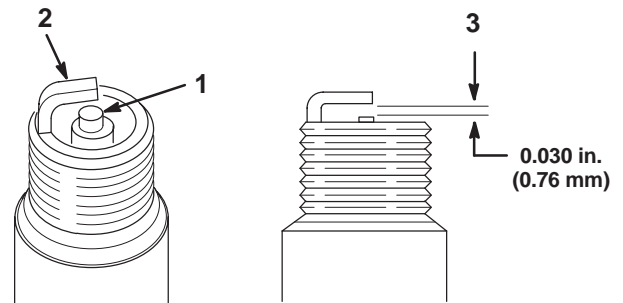

**Figure 25**

- Center electrode insulator
- Side electrode
- Air gap (not to scale)

## Installing the Spark Plugs

- Thread the spark plugs into the spark plug holes.
- Tighten the spark plugs to 20 ft.-lb (27 N.m).
- Push the wires onto the spark plugs (Fig. 24).

## Servicing the Hydraulic System

### Replacing the Hydraulic Filter

Change the hydraulic filter:

- After the first 8 to 10 operating hours.
  - After every 400 operating hours.
- Position traction unit on a level surface.
  - Raise the loader arms and install the cylinder locks; refer to Using the Cylinder Locks, page 18.
  - Stop the engine and remove the key.
  - Remove the hood, refer to Removing the Hood, page 21.

**Important** Do not substitute an automotive oil filter or severe hydraulic system damage may result.

5. Place a drain pan under the filter.
6. Remove the old filter and wipe the filter adapter, gasket surface clean.
7. Apply a thin coat hydraulic fluid to the rubber gasket on the replacement filter (Fig. 26).
8. Install the replacement hydraulic filter onto the filter adapter. Tighten it clockwise until the rubber gasket contacts the filter adapter, then tighten the filter an additional 1/2 turn (Fig. 26).
9. Clean up any spilled fluid.
10. Start the engine and let it run for about two minutes to purge air from the system.
11. Stop the engine and check for leaks.
12. Check the fluid level in the hydraulic tank (refer to Checking the Hydraulic Fluid, page 13) and add fluid to raise the level to mark on dipstick. Do not over fill the tank.

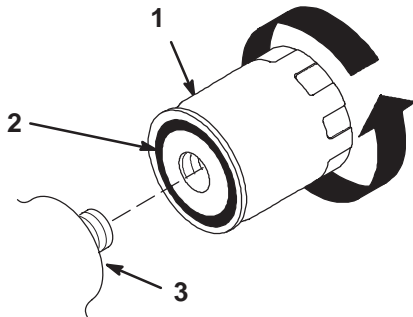

**Figure 26**

1. Hydraulic filter
2. Gasket
3. Adapter

13. Install the hood; refer to Installing the Hood, page 21.
14. Remove and store the cylinder locks (refer to Using the Cylinder Locks, page 18) and lower the loader arms.

## Changing the Hydraulic Fluid

Change the hydraulic fluid yearly.

1. Position traction unit on a level surface.
2. Raise the loader arms and install the cylinder locks; refer to Using the Cylinder Locks, page 18.
3. Stop the engine and remove the key.
4. Remove the hood; refer to Removing the Hood, page 21.

5. Place a large drain pan under the traction unit that can hold at least 17 gal. (67 l).
6. Remove the drain plug from the bottom of the hydraulic tank and allow the fluid to completely drain out.
7. Install the drain plug.
8. Fill the hydraulic tank with approximately 15 gal. 10W-30 detergent, diesel engine oil (API service CH-4 or higher) (refer to Checking Hydraulic Fluid, page 13).

**Important** Do not substitute automotive transmission fluid or severe hydraulic system damage may result.

**Note:** Dispose of used oil at a certified recycling center.

9. Install the hood; refer to Installing the Hood, page 21.
10. Remove and store the cylinder locks (refer to Using the Cylinder Locks, page 18) and lower the loader arms.

## Checking Hydraulic Lines

After every 25 operating hours, check the hydraulic lines and hoses for leaks, loose fittings, kinked lines, loose mounting supports, wear, weather, and chemical deterioration. Replace all moving hydraulic hoses every 1500 hours or 2 years, whichever comes first. Make necessary repairs before operating.



### Warning



**Hydraulic fluid escaping under pressure can penetrate skin and cause injury. Fluid injected into the skin must be surgically removed within a few hours by a doctor familiar with this form of injury or gangrene may result.**

- **Keep your body and hands away from pin hole leaks or nozzles that eject high pressure hydraulic fluid.**
- **Use cardboard or paper to find hydraulic leaks, never use your hands.**

## Replacing the Fuel Filter

Replace the fuel filter yearly. Never install a dirty filter.

1. Lower the loader arms and stop the engine. Remove the key.
2. Shut off the fuel valve on the bottom of each fuel tank (Fig. 28).
3. Clamp the fuel line between the fuel tanks and the fuel filter to block the fuel flow.
4. Squeeze the ends of the hose clamps together and slide them away from the filter (Fig. 27).
5. Place a drain pan under the fuel lines to catch any leaks, then remove the filter from the fuel lines.
6. Install a new filter and move the hose clamps close to the filter.
7. Remove the clamp blocking fuel flow and open the fuel valves.

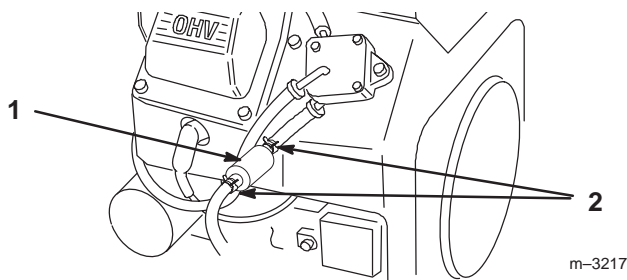

**Figure 27**

1. Filter
2. Hose clamp

## Draining the Fuel Tanks

**Danger**

**In certain conditions, gasoline is extremely flammable and highly explosive. A fire or explosion from gasoline can burn you and others and can damage property.**

- **Drain gasoline from the fuel tank when the engine is cold. Do this outdoors in an open area. Wipe up any gasoline that spills.**
- **Never smoke when draining gasoline, and stay away from an open flame or where a spark may ignite the gasoline fumes.**

1. Park the traction unit on a level surface, to ensure that the fuel tanks drain completely.
2. Lower the loader arms and stop the engine. Remove the key.

3. Shut off the fuel valve on the bottom of each fuel tank (Fig. 28).

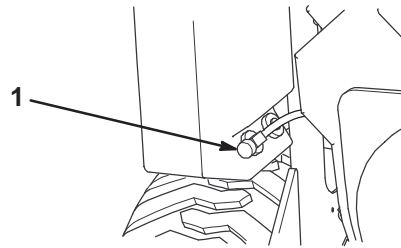

**Figure 28**

1. Fuel valve
- 
4. Loosen the hose clamp at the fuel filter and slide it up the fuel line away from the filter.
  5. Pull the fuel line off of the fuel filter, open the fuel valves, and allow the gasoline to drain into a gas can or drain pan.
- Note:** Now is the best time to install a new fuel filter because the fuel tanks are empty.
6. Install the fuel line onto the fuel filter.
  7. Slide the hose clamp close to the fuel filter to secure the fuel line.
  8. Open the fuel valve on the bottom of each fuel tank.

## Cleaning and Storage

1. Lower the loader arms and stop the engine. Remove the key.
2. Remove dirt and grime from the external parts of the entire traction unit, especially the engine. Clean dirt and chaff from the outside of the engine's cylinder head fins and blower housing.

**Important** You can wash the traction unit with mild detergent and water. Do not pressure wash the traction unit. Avoid excessive use of water, especially near the control panel, engine, hydraulic pumps, and motors.

3. Service the air cleaner; refer to Servicing the Air Cleaner, page 22.
4. Grease the traction unit; refer to Greasing the Traction Unit, page 22.
5. Change the crankcase oil; refer to Servicing the Engine Oil, page 23.
6. Remove the spark plugs and check the condition of each; refer to Servicing the Spark Plugs, page 25.
7. With the spark plugs removed from the engine, pour two tablespoons of engine oil into each spark plug hole.

8. Place rags over the spark plug holes to catch any oil spray, then use the starter to crank the engine and distribute the oil inside the cylinder.
9. Install the spark plugs, but do not install the wires on the spark plugs.
10. Check the tire pressure; refer to Tire Pressure, page 13.
11. Charge the battery; refer to Servicing the Battery, page 24.
12. For storage over 30 days, prepare the traction unit as follows.
  - A. Add a petroleum based stabilizer/conditioner to fuel in the tank. Follow mixing instructions from stabilizer manufacturer (1 oz. per gal.). **Do not use an alcohol based stabilizer (ethanol or methanol).**

**Note:** A fuel stabilizer/conditioner is most effective when mixed with fresh gasoline and used at all times.

- B. Run the engine to distribute conditioned fuel through the fuel system (5 minutes).

- C. Stop the engine, allow it to cool, and drain the fuel tanks; refer to Draining Fuel Tanks, page 27.
- D. Start the engine and run it until it stops.
- E. Choke the engine.
- F. Start and run the engine until it will not start again.
- G. Dispose of fuel properly. Recycle as per local codes.

**Important** Do not store stabilizer/conditioned gasoline over 90 days.

13. Check and tighten all bolts, nuts, and screws. Repair or replace any part that is damaged or defective.
14. Paint all scratched or bare metal surfaces. Paint is available from your Authorized Service Dealer.
15. Store the traction unit in a clean, dry garage or storage area. Remove the key from the ignition switch and keep it in a memorable place.
16. Cover the traction unit to protect it and keep it clean.

## Troubleshooting

PROBLEM	POSSIBLE CAUSES	CORRECTIVE ACTION
Starter does not crank	<ol style="list-style-type: none"> <li>1. Auxiliary hydraulics lever is not in neutral position.</li> <li>2. Battery is dead.</li> <li>3. Electrical connections are corroded or loose.</li> <li>4. Relay or switch is defective.</li> </ol>	<ol style="list-style-type: none"> <li>1. Move lever to neutral position.</li> <li>2. Charge the battery.</li> <li>3. Check electrical connections for good contact.</li> <li>4. Contact Authorized Service Dealer.</li> </ol>
Engine will not start, starts hard, or fails to keep running.	<ol style="list-style-type: none"> <li>1. Fuel tanks are empty.</li> <li>2. Choke is not on.</li> <li>3. Air cleaner is dirty.</li> <li>4. Spark plug wires are loose or disconnected.</li> <li>5. Spark plugs are pitted, fouled, or gap is incorrect.</li> <li>6. Dirt in fuel filter.</li> <li>7. Dirt, water, or stale fuel is in fuel system.</li> </ol>	<ol style="list-style-type: none"> <li>1. Fill fuel tanks with gasoline.</li> <li>2. Move choke lever fully forward.</li> <li>3. Clean or replace air cleaner element.</li> <li>4. Install wires on spark plugs.</li> <li>5. Install new, correctly gapped spark plugs.</li> <li>6. Replace fuel filter.</li> <li>7. Contact Authorized Service Dealer.</li> </ol>

<b>PROBLEM</b>	<b>POSSIBLE CAUSES</b>	<b>CORRECTIVE ACTION</b>
Engine loses power.	<ol style="list-style-type: none"> <li>1. Engine load is excessive.</li> <li>2. Air cleaner is dirty.</li> <li>3. Oil level in crankcase is low.</li> <li>4. Cooling fins and air passages under engine blower housing are plugged.</li> <li>5. Spark plugs are pitted, fouled, or gap is incorrect.</li> <li>6. Dirt in fuel filter.</li> <li>7. Dirt, water, or stale fuel is in fuel system.</li> </ol>	<ol style="list-style-type: none"> <li>1. Reduce ground speed.</li> <li>2. Clean air cleaner element.</li> <li>3. Add oil to crankcase.</li> <li>4. Remove obstruction from cooling fins and air passages.</li> <li>5. Install new, correctly gapped spark plugs.</li> <li>6. Replace fuel filter.</li> <li>7. Contact Authorized Service Dealer.</li> </ol>
Engine overheats.	<ol style="list-style-type: none"> <li>1. Engine load is excessive.</li> <li>2. Oil level in crankcase is low.</li> <li>3. Cooling fins and air passages under engine blower housing are plugged.</li> </ol>	<ol style="list-style-type: none"> <li>1. Reduce ground speed.</li> <li>2. Add oil to crankcase.</li> <li>3. Remove obstruction from cooling fins and air passages.</li> </ol>
Abnormal vibration.	<ol style="list-style-type: none"> <li>1. Engine mounting bolts are loose.</li> </ol>	<ol style="list-style-type: none"> <li>1. Tighten engine mounting bolts.</li> </ol>
Traction unit does not drive.	<ol style="list-style-type: none"> <li>1. Flow divider valve lever is in the 9 o'clock position.</li> <li>2. Tow-valves are open.</li> <li>3. Hydro fluid level low.</li> <li>4. Traction pump drive coupler is loose or broken.</li> <li>5. Pump and/or wheel motor is defective or damaged.</li> <li>6. Control valve is defective or damaged.</li> <li>7. Relief valve is defective or damaged.</li> </ol>	<ol style="list-style-type: none"> <li>1. Move the lever to the 12 to 10 o'clock position.</li> <li>2. Close the tow-valves.</li> <li>3. Add hydro fluid to reservoir.</li> <li>4. Contact Service Dealer.</li> <li>5. Contact Service Dealer.</li> <li>6. Contact Service Dealer.</li> <li>7. Contact Service Dealer.</li> </ol>
When at rest, loader arms creep downward more than 3" per hour (less than 3" an hour is normal for this traction unit).*	<ol style="list-style-type: none"> <li>1. Valve spool leakage</li> </ol>	<ol style="list-style-type: none"> <li>1. Contact Service Dealer.</li> </ol>
When at rest, loader arms settle downward 2" quickly and then stop.*	<ol style="list-style-type: none"> <li>1. Cylinder seals are leaking</li> <li>2. Cylinder rephase valve is leaking</li> </ol>	<ol style="list-style-type: none"> <li>1. Replace seals.</li> <li>2. Contact Service Dealer.</li> </ol>







# The Toro Dingo<sup>®</sup> Product Line Warranty

## A One-Year Limited Warranty

### Conditions and Products Covered

The Toro Company and its affiliate, Toro Warranty Company, pursuant to an agreement between them, jointly warrant your Toro Dingo Product ("Product") to be free from defects in materials or workmanship for one year or 500 operational hours, whichever occurs first. Where a warrantable condition exists, we will repair the Product at no cost to you including diagnosis, labor, and parts. This warranty begins on the date the Product is delivered to the original retail purchaser.

### Instructions for Obtaining Warranty Service

Should you feel your Toro Product contains a defect in materials or workmanship, contact the distributor or dealer who sold you the product or any Authorized Dingo Service Dealer. The Yellow Pages of your telephone directory is a good reference source. The dealer will arrange service at his/her dealership. You may need proof of purchase (copy of registration card, sales receipt, etc.) for warranty validation.

If for any reason you are dissatisfied with the Service Dealer's analysis of the defect in materials or workmanship or if you need a referral to a Toro Dingo Service Dealer, please feel free to contact us at:

LCB Customer Service Department  
Toro Warranty Company  
8111 Lyndale Avenue South  
Bloomington, MN 55420-1196  
952-888-8801 or 888-577-7466

### Owner Responsibilities

You must maintain your Toro Product by following the maintenance procedures described in the operator's manual. Such routine maintenance, whether performed by a dealer or by you, is at your expense. Parts scheduled for replacement as required maintenance ("Maintenance Parts"), are warranted for the period of time up to the scheduled replacement time for that part. Failure to perform required maintenance and adjustments can be grounds for disallowing a warranty claim.

### Items and Conditions Not Covered

Not all product failures or malfunctions that occur during the warranty period are defects in materials or workmanship. This express warranty does not cover the following:

- Product failures which result from the use of non-Toro replacement parts, or from installation and use of add-on, modified, or unapproved accessories
- Product failures which result from failure to perform required maintenance and/or adjustments

### Countries Other than the United States or Canada

Customers who have purchased Toro products exported from the United States or Canada should contact their Toro Distributor (Dealer) to obtain guarantee policies for your country, province, or state. If for any reason you are dissatisfied with your Distributor's service or have difficulty obtaining guarantee information, contact the Toro importer. If all other remedies fail, you may contact us at Toro Warranty Company.

- Product failures which result from operating the Product in an abusive, negligent or reckless manner
- Parts subject to consumption through use unless found to be defective. Examples of parts which are consumed, or used up, during normal Product operation include, but are not limited to, digging teeth, tines, spark plugs, tires, tracks, filters, chains, etc.
- Failures caused by outside influence. Items considered to be outside influence include, but are not limited to, weather, storage practices, contamination, use of unapproved coolants, lubricants, additives, or chemicals, etc.
- Normal "wear and tear" items. Normal "wear and tear" includes, but is not limited to, worn painted surfaces, scratched decals or windows, etc.
- Any component covered by a separate manufacturer's warranty
- Pickup and delivery charges

### General Conditions

Repair by an Authorized Toro Service Dealer is your sole remedy under this warranty.

Neither The Toro Company nor Toro Warranty Company is liable for indirect, incidental or consequential damages in connection with the use of the Toro Products covered by this warranty, including any cost or expense of providing substitute equipment or service during reasonable periods of malfunction or non-use pending completion of repairs under this warranty. Some states do not allow exclusions of incidental or consequential damages, or limitations on how long an implied warranty lasts, so the above exclusions and limitations may not apply to you.

This warranty gives you specific legal rights, and you may also have other rights which vary from state to state.

Except for the Emissions warranty referenced below, if applicable, there is no other express warranty. All implied warranties of merchantability and fitness for use are limited to the duration of this express warranty.

**Note to California residents:** The Emissions Control System on your Product may be covered by a separate warranty meeting requirements established by the U.S. Environmental Protection Agency (EPA) or the California Air Resources Board (CARB). The hour limitations set forth above do not apply to the Emissions Control System Warranty. Refer to the California Emission Control Warranty Statement printed in your operator's manual or contained in the engine manufacturer's documentation for details.