



Count on it.

Parts Catalog

**eTurfmaster 30in 60V
Lawn Mower**

Model No. 22232—Serial No. 400000000 and Up



Ordering Replacement Parts

To order replacement parts, please supply the part number, the quantity, and the description of each part desired.

Understanding Reference Numbers

Each identified part in an illustration has a reference number. The reference number for a part also appears in the parts list, along with other information about the part.

This catalog uses two special reference number formats, one to indicate parts in a service assembly and another to indicate the quantity of a given part in an illustration.

Service Assembly Reference Numbers

Parts in service assemblies have reference numbers in the form a:b. The a represents the reference number of the entire service assembly and the b represents a sequential number unique to each part within the service assembly.

For example, a wheel assembly might be identified by reference number 6, the tire by 6:1, the valve by 6:2, and the wheel by 6:3. When you order the assembly identified by reference number 6, you receive all parts identified by reference numbers 6:1, 6:2, and 6:3. However, you may also order any part individually. Reference numbers of this type appear in illustration and in parts lists.

Reference Numbers Indicating Quantity

In an illustration, if a reference number indicates more than one part, the reference number has the form nX y. The n represents the quantity of the part, the X is the multiplication symbol, and the y represents the reference number.

For example, in an illustration, the reference number 2X 37 means that two of the parts identified by reference number 37 are indicated.

Contents

Deck Assembly	4
Spindle and Blade Assembly	6
Side Discharge Chute Assembly	8
Grass Bag Assembly	10
Decal Assembly	12
Motor Module and Belt Assembly	14
Motor Module Assembly No. 147-0486	16
Front Wheel and Height-of-Cut Assembly	18
Transmission and HOC Assembly	20
Handle Assembly	22
Attachments and Accessories	24

Deck Assembly

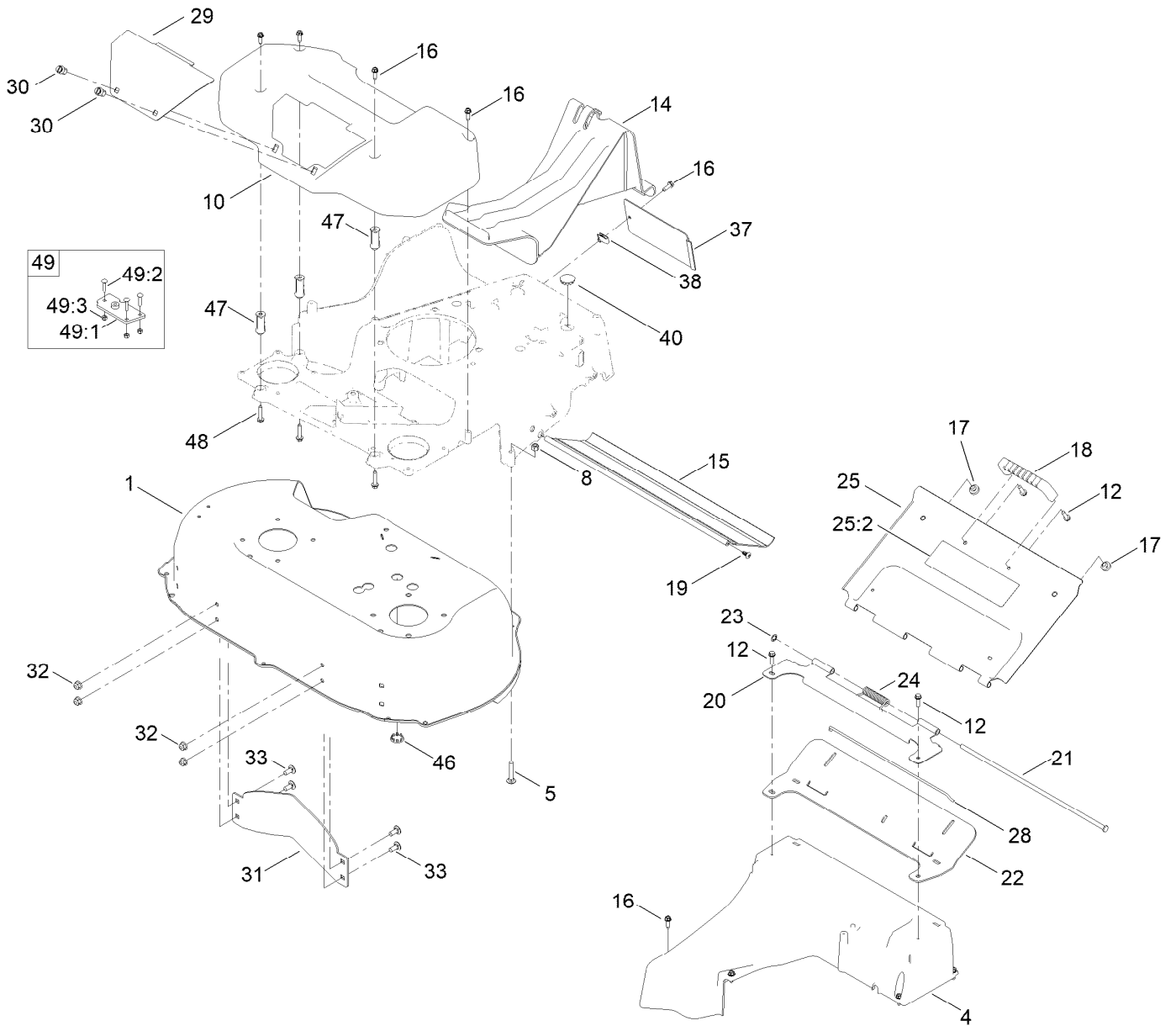

Deck Assembly (continued)

<i>Ref.</i>	<i>Part Number</i>	<i>Qty.</i>	<i>Description</i>	<i>Ref.</i>	<i>Part Number</i>	<i>Qty.</i>	<i>Description</i>
1	147-0494-01	1	Turfmaster 30 Deck ASM [red]	25	116-8355	1	Rear Door ASM
4	133-8177	1	Chute	25:2	116-7583	1	Decal-Warning
5	3230-5	2	Bolt-CARR	28	116-6966	1	Clip-Seal
8	3296-29	2	Nut-Lock, NI	29	145-5899-03	1	Panel-Access
10	145-5898	1	Cover-Belt	30	121-5840	2	Fastener
12	46-8091	4	Screw-HWH	31	130-2352-01	1	Baffle-Control
14	120-5225	1	Plug-Mulch	32	104-8300	4	Nut-HF, NI
15	121-5841	1	Shield-Trailing	33	3230-23	4	Bolt-CARR
16	49-2040	10	Screw-HWHTF	37	138-5332-01	1	Cover-Frame
17	1-513658	2	Bumper	38	107069	1	Clip
18	65-5100	1	Handle-Door	40	126-7151	1	Plug-Button
19	117-1092	2	Screw-PTH	46	147-0471	1	Plug-Button
20	116-6351-03	1	Bracket-Hinge	47	140-3901	3	Spacer-Frame, 30 In.
21	116-6933	1	Pin-Hinge	48	108-4862	3	Screw-HWH Thd Roll
22	116-6229	1	Seal-Door	49	161-3140	1	Frame-Plate Kit
23	32151-72	1	Ring-Retaining	49:1	161-3141	1	Plate-Frame, ASM
24	116-7573	1	Spring-Torsion, Cover	49:2	3229-3	3	Screw-CARR
				49:3	3296-42	3	Nut-Lock, NI

Spindle and Blade Assembly

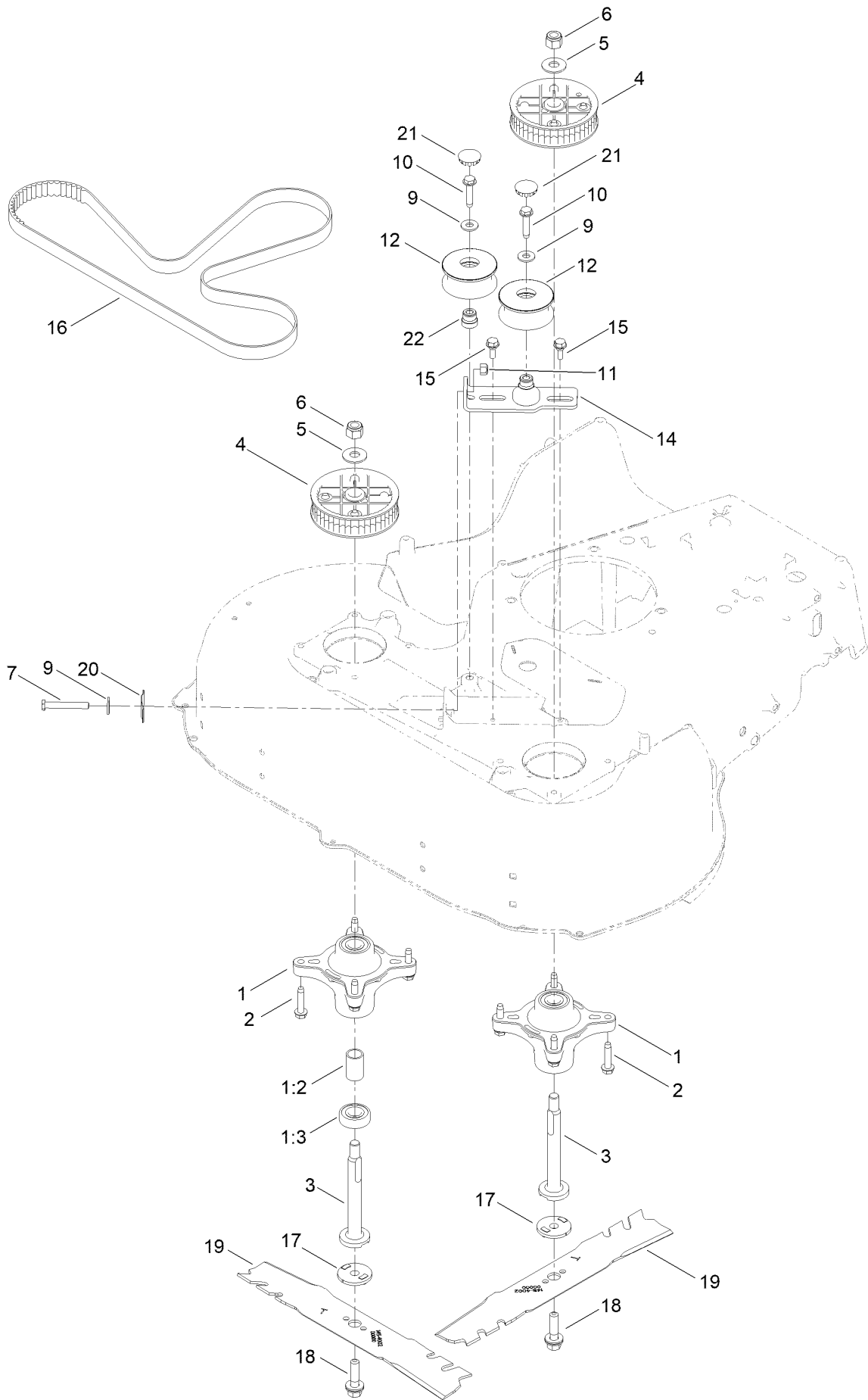

Spindle and Blade Assembly (continued)

<i>Ref.</i>	<i>Part Number</i>	<i>Qty.</i>	<i>Description</i>	<i>Ref.</i>	<i>Part Number</i>	<i>Qty.</i>	<i>Description</i>
1	121-9107	2	Spindle ASM	12	126-5880	2	Pulley-Idler, Flat
1:2	120-7935	2	Spacer	12	126-7890	1	Pulleys And Idler Kit
1:3	138-9770	2	Bearing-Ball	14	147-0470	1	Bracket-Idler
2	139-1731	8	Screw-Thd Roll, HWH	15	120-7024	2	Screw-Shoulder, HWH
3	139-6612	2	Shaft-Spindle	16	145-4001	1	Belt-Synchronous
4	121-9100	2	Sprocket	17	120-5236	2	Adapter-Blade
5	109-9505	2	Washer-Spring	18	125-2466	2	Bolt-Blade
6	3296-19	2	Nut-Hex	19	145-4002-03	2	Blade-Rotary [black]
7	9114524	1	Bolt-TAP, HH	20	121-2336	1	Spring-Flat
9	3256-3	2	Washer-Flat	21	126-7151	2	Plug-Button
10	32144-57	2	Screw	22	131-4504	1	Adapter-Bore
11	3296-29	1	Nut-Lock, NI				

Side Discharge Chute Assembly

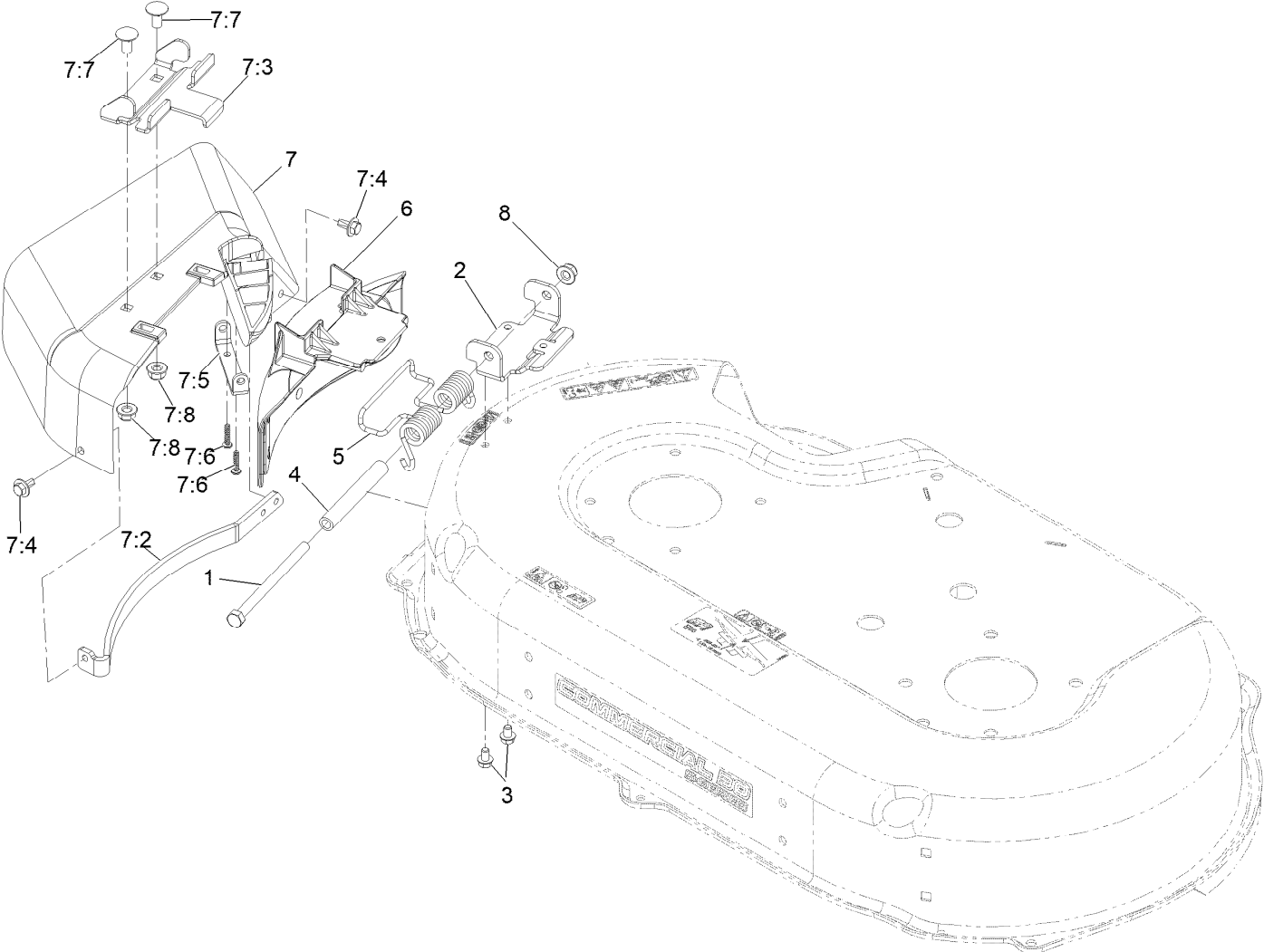

Side Discharge Chute Assembly (continued)

<i>Ref.</i>	<i>Part Number</i>	<i>Qty.</i>	<i>Description</i>	<i>Ref.</i>	<i>Part Number</i>	<i>Qty.</i>	<i>Description</i>
1	322-38	1	Screw-HH	7:3	121-9196	1	Bracket-Chute
2	121-9195	1	Hinge	7:4	46-8560	2	Screw-HHFTF
3	137-4795	2	Screw	7:5	112-6416	1	Bracket-Cover
4	125-2478	1	Spacer	7:6	94-4496	2	Screw-PPH
5	121-9193	1	Spring-Torsion	7:7	3230-18	2	Screw-CARR
6	125-5093-01	1	Cover-Discharge	7:8	104-8300	2	Nut-HF, NI
7	116-9754	1	Side Discharge Chute ASM	8	104-8300	1	Nut-HF, NI
7:2	116-9752-03	1	Guard-Chute				

Grass Bag Assembly

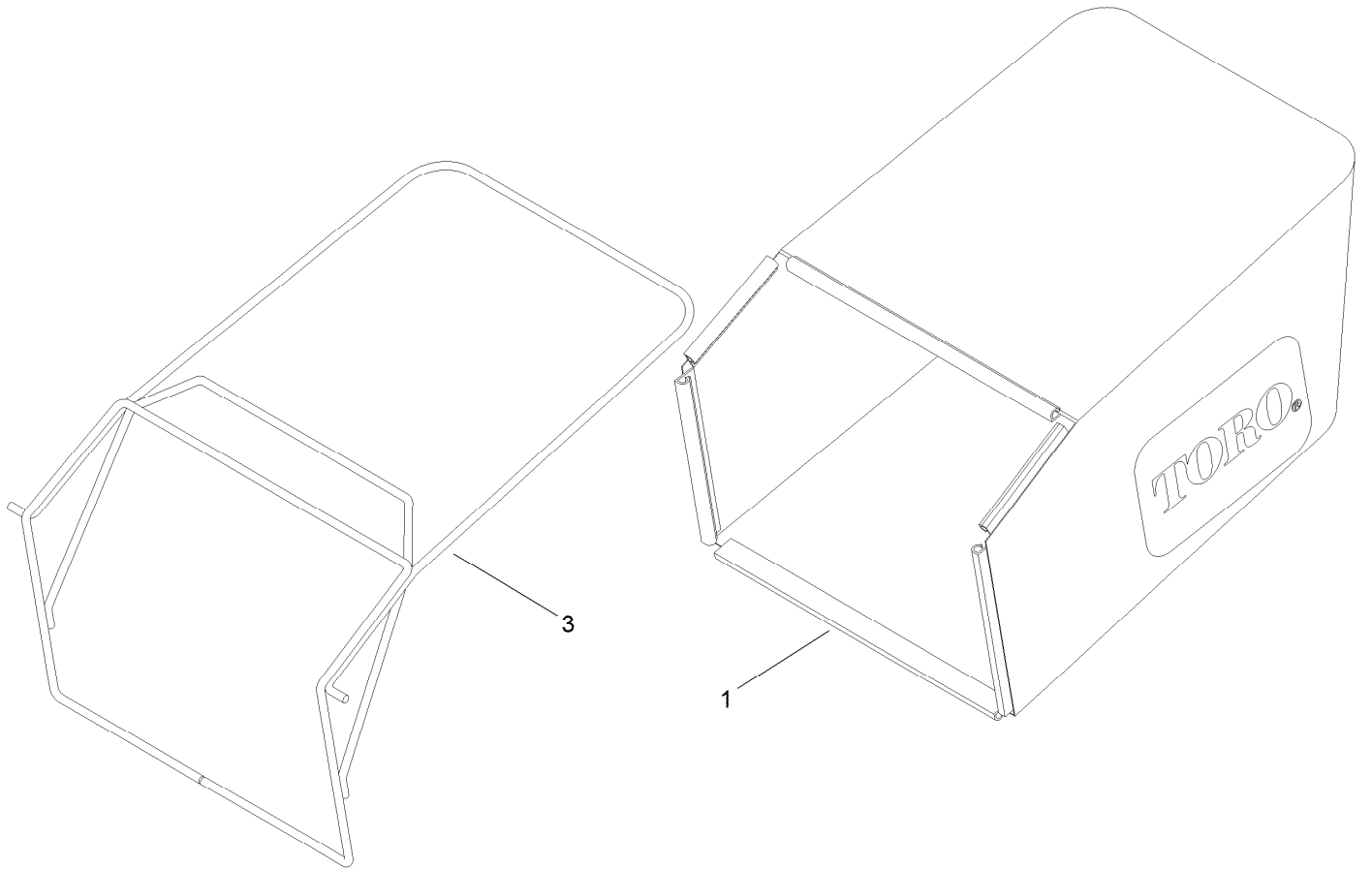

Grass Bag Assembly (continued)

<i>Ref.</i>	<i>Part Number</i>	<i>Qty.</i>	<i>Description</i>
1	121-5775	1	Grass Bag ASM
3	116-5596-03	1	Frame-Bag

Decal Assembly

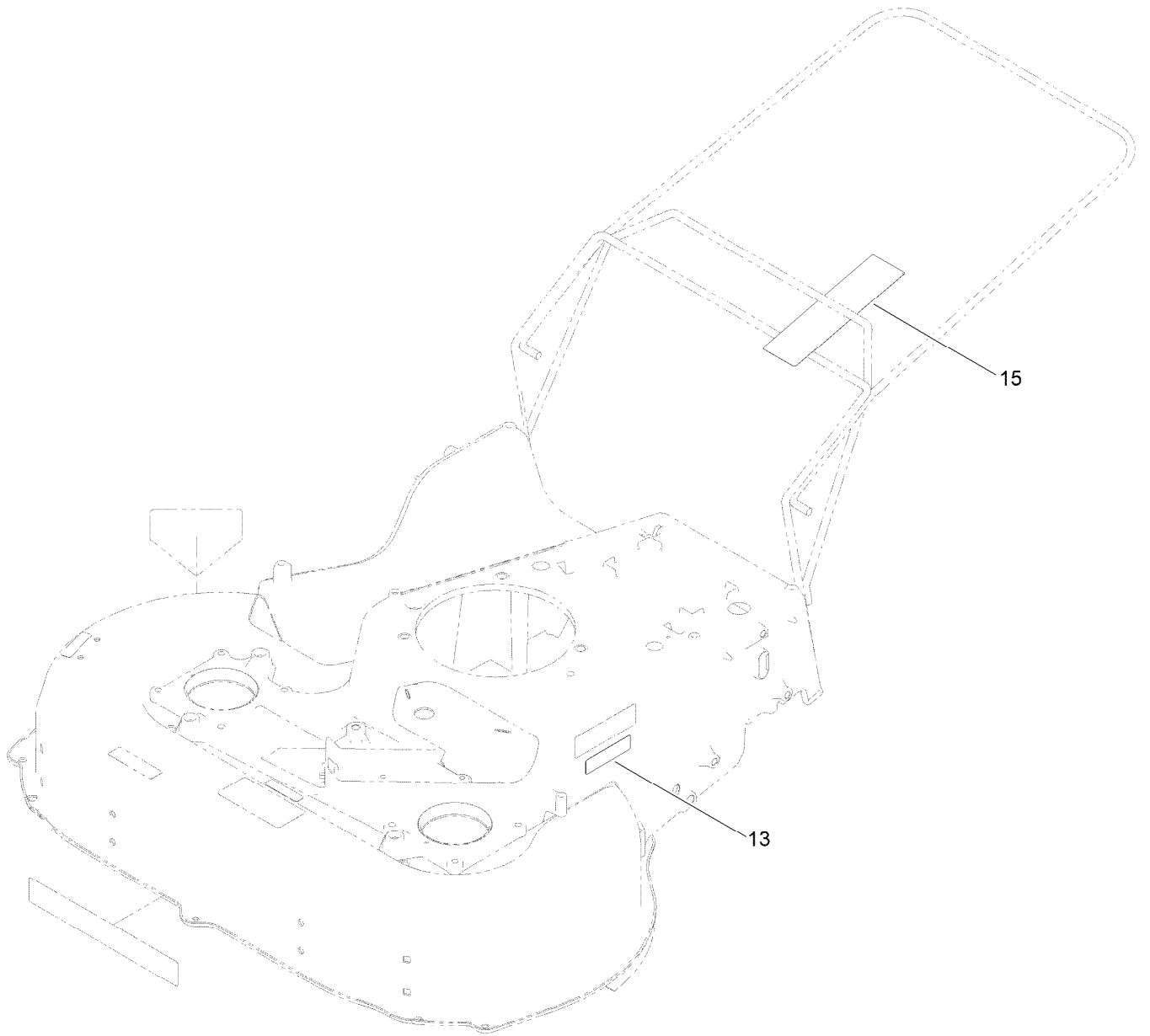

Decal Assembly (continued)

<i>Ref.</i>	<i>Part Number</i>	<i>Qty.</i>	<i>Description</i>
13	133-8054	1	Decal-Prop 65, Short, Trilingual
15	139-8986	1	Decal-Warning (Bag)

Motor Module and Belt Assembly

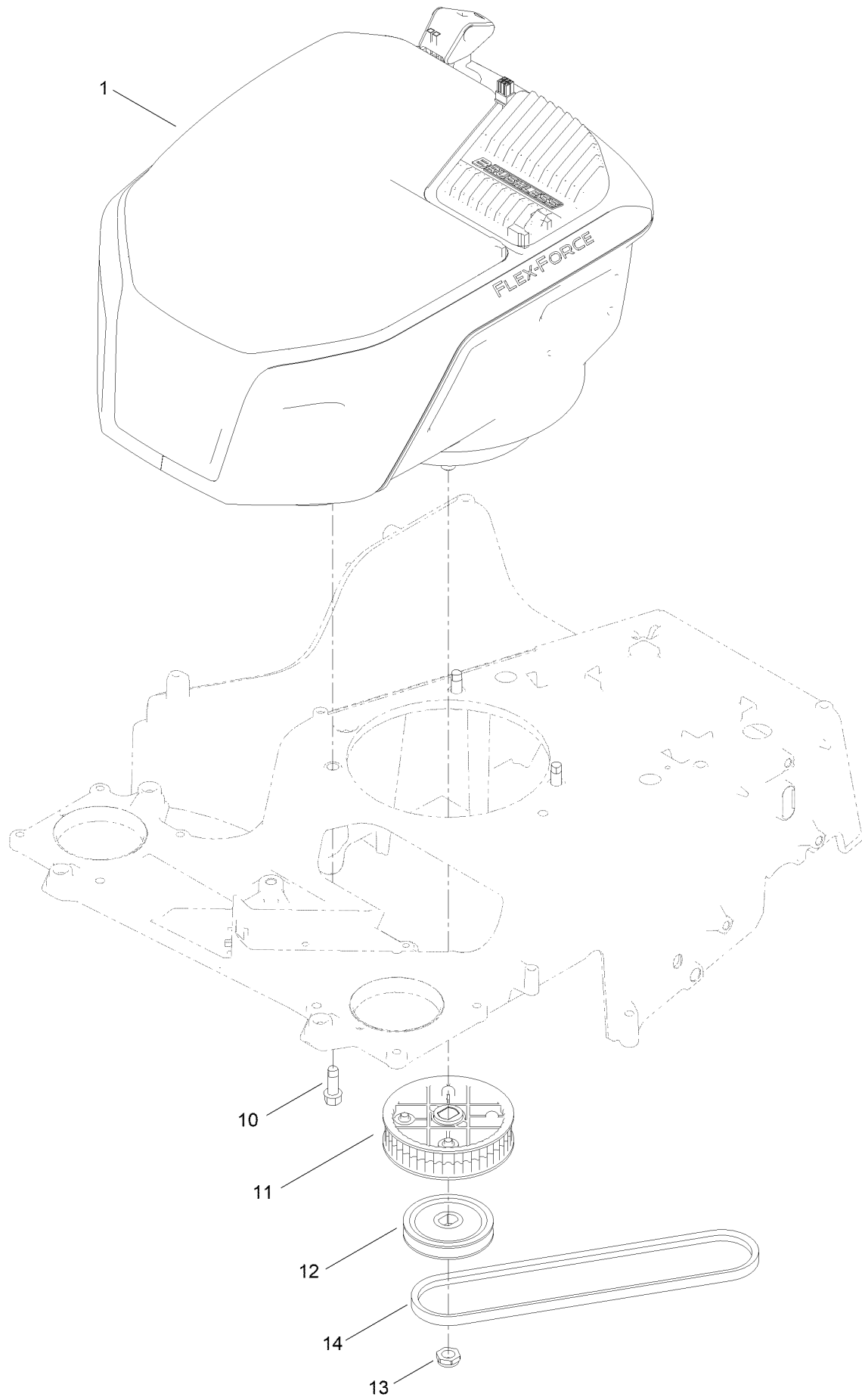

Motor Module and Belt Assembly (continued)

<i>Ref.</i>	<i>Part Number</i>	<i>Qty.</i>	<i>Description</i>	<i>Ref.</i>	<i>Part Number</i>	<i>Qty.</i>	<i>Description</i>
1	147-0486	1	Motor Module 60V	12	147-0472	1	Pulley-Traction
10	121-5844	3	Screw-Thd Form, HWH	13	3296-28	1	Nut-Lock, NI
11	121-9100	1	Sprocket	14	133-8151	1	Belt-V

Motor Module Assembly No. 147-0486

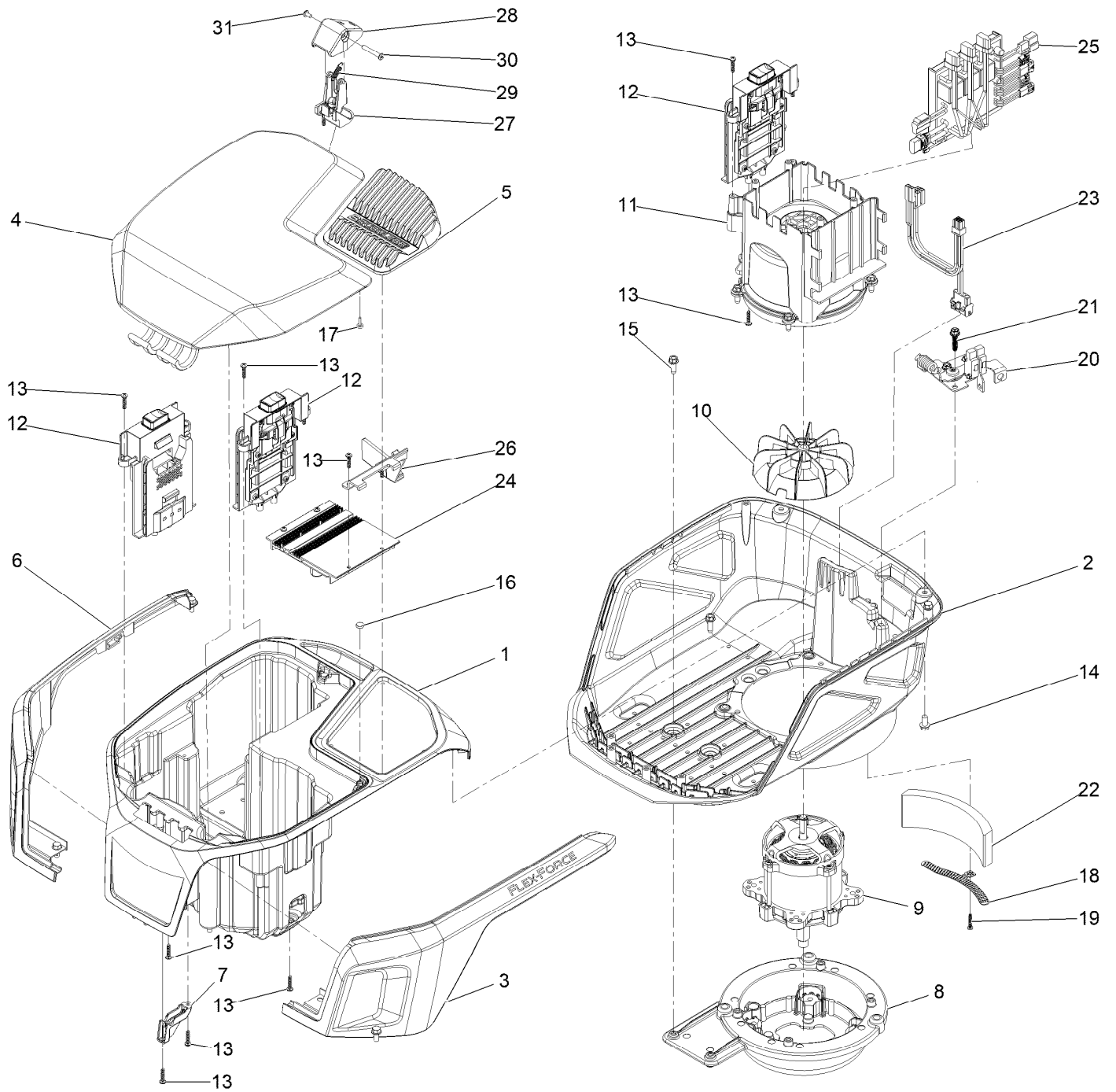

Motor Module Assembly No. 147-0486 (continued)

<i>Ref.</i>	<i>Part Number</i>	<i>Qty.</i>	<i>Description</i>	<i>Ref.</i>	<i>Part Number</i>	<i>Qty.</i>	<i>Description</i>
1	145-5882	1	Bucket-Battery	17	95-4234	2	Screw-PPH
2	145-5883	1	Shroud-Lower	18	147-0449	1	Bracket-Foam
3	147-0406	1	Trim-Shroud, LH	19	138-3273	1	Screw-Plastic, PPH
4	145-5885	1	Lid-Motor	20	133-1918	1	Bail Switch ASM
5	145-5886	1	Heatsink-Controller	21	130-6658	2	Screw-Flange, Plastic
6	147-0407	1	Trim-Shroud, RH	22	145-3972	1	Foam
7	145-5892	2	Bracket-Support, Lid	23	139-6637	1	Harness-Wire
8	145-5895	1	Mount-Base, Motor	24	147-0451	1	Controller-Pmu
9	145-4048	1	Motor-60V	25	147-0452	1	Controller-Motor
10	145-5896	1	Fan-Motor	26	161-3110	1	Bracket-Pmu
11	145-5897	1	Shroud-Motor	27	147-8634	1	Lidlock-Base
12	147-0403	3	Receiver-Battery	28	147-8633	1	Lidlock-Lever
13	94-4496	21	Screw-PPH	29	161-3111	1	Spring
14	46-8093	8	Screw-Plastite	30	161-3112	1	Screw-Pin, Hinge
15	49-2040	6	Screw-HWHTF	31	161-3113	1	Screw-Pin
16	114-5896	2	Magnet				

Front Wheel and Height-of-Cut Assembly

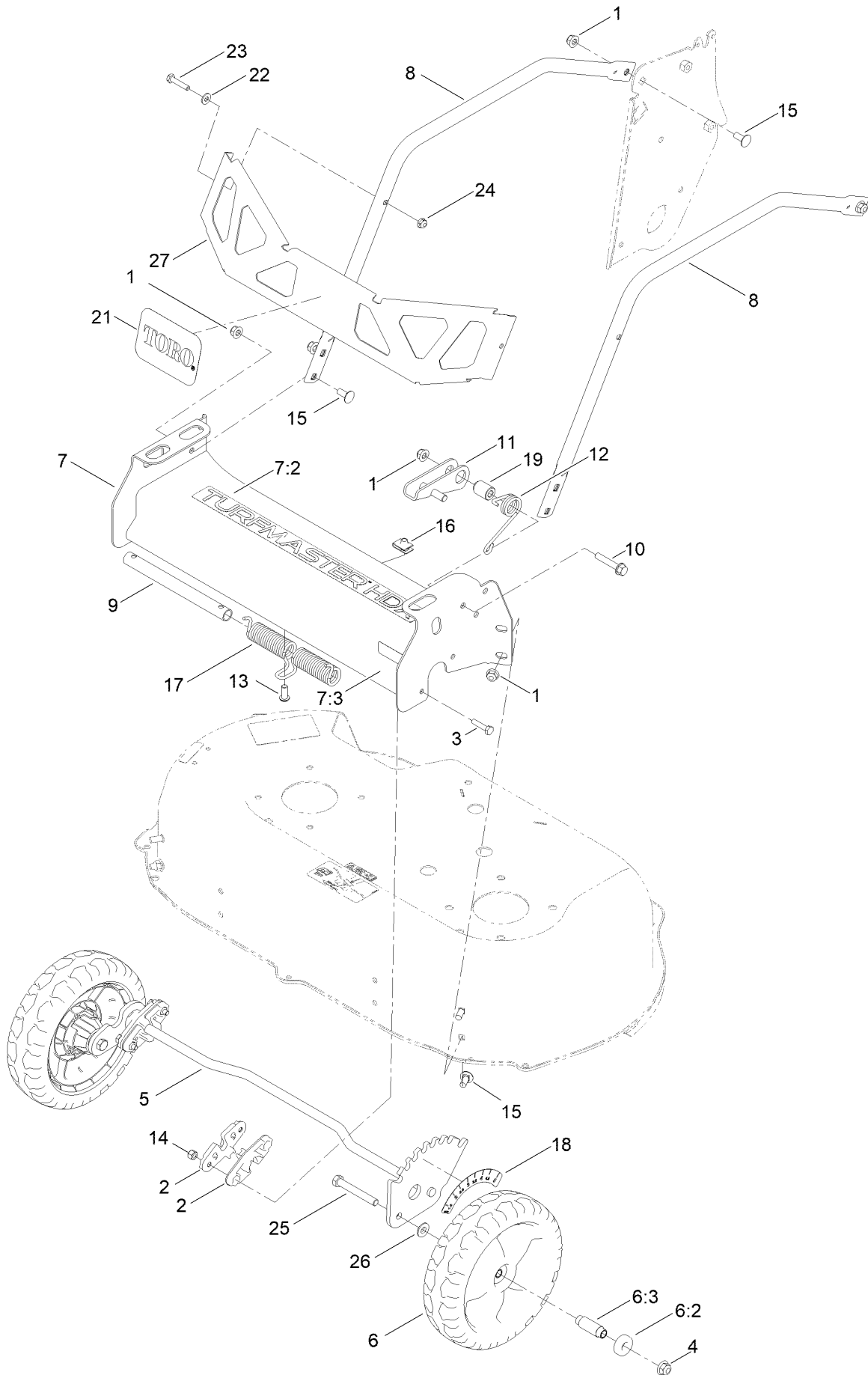

Front Wheel and Height-of-Cut Assembly (continued)

<i>Ref.</i>	<i>Part Number</i>	<i>Qty.</i>	<i>Description</i>	<i>Ref.</i>	<i>Part Number</i>	<i>Qty.</i>	<i>Description</i>
1	104-8300	11	Nut-HF, NI	12	120-9465	1	Spring-Torsion
2	121-5781	4	Bushing-Front	13	3274-55	1	Screw-HSBH
3	321-7	4	Screw-HH	14	3296-42	4	Nut-Lock, NI
4	104-8301	2	Nut-HF, NI	15	3230-23	10	Bolt-CARR
5	139-8968	1	Front Axle ASM	16	94-2413	1	Nut-U
6	133-2639	2	Wheel	17	121-2337	1	Spring-Torsion
6:2	133-2603	2	Bearing-Ball	18	136-9077	1	Decal-HOC, Front
6:3	125-1077	1	Spacer	19	125-2486	1	Spacer
7	139-6616	1	Front Bumper ASM	21	117-0871	1	Decal
7:2	139-1675	1	Decal-Turfmaster HDX	22	3256-22	2	Washer-Flat
7:3	116-7581	1	Decal-Warning	23	321-8	2	Screw-HH
8	121-9168-03	2	Brace	24	104-7201	2	Nut-HF, NI
9	131-9690	1	Mandrell-Spring	25	323-13	2	Screw-HH
10	94-5780	1	Screw-HWH	26	74-1671	2	Spacer-Cover, Wheel
11	139-1744	1	Lock-Height, Adj	27	147-0473-03	1	Guard-Engine

Transmission and HOC Assembly

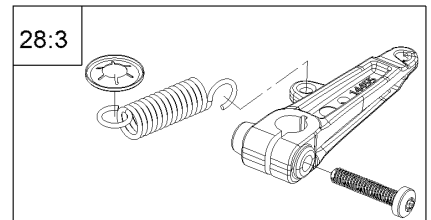
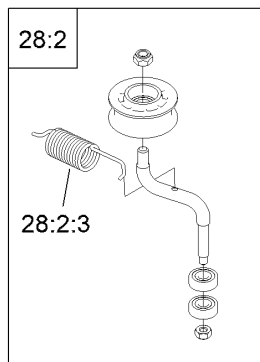
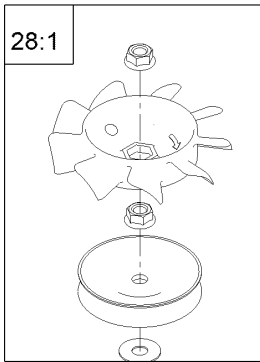
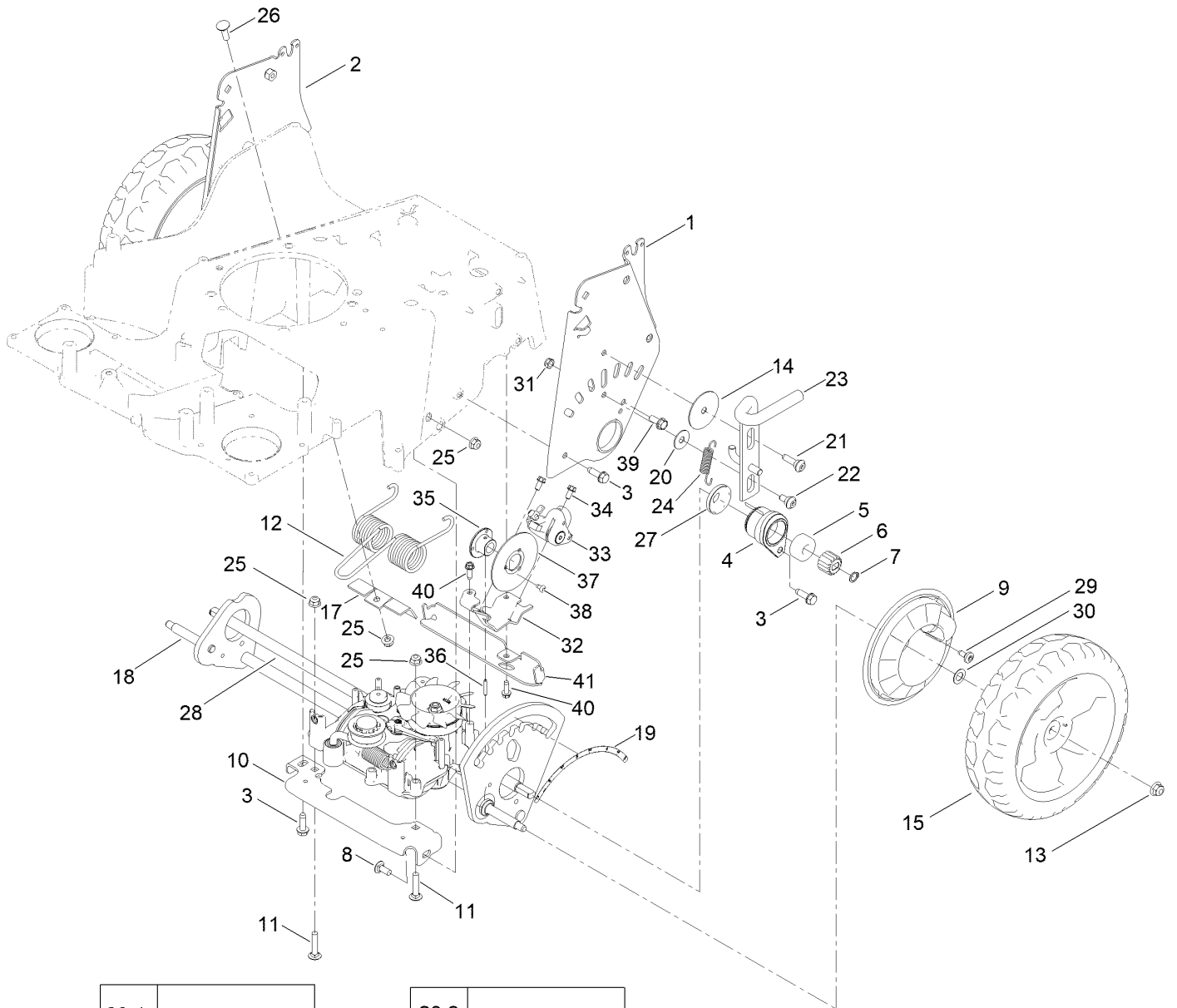

Transmission and HOC Assembly (continued)

<i>Ref.</i>	<i>Part Number</i>	<i>Qty.</i>	<i>Description</i>	<i>Ref.</i>	<i>Part Number</i>	<i>Qty.</i>	<i>Description</i>
1	137-9172-03	1	HOC Plate Assembly	25	104-8300	4	Nut-HF, NI
2	137-9173-03	1	HOC Plate Assembly	26	3230-2	1	Bolt-CARR
3	701243	7	Screw-Thd Roll, HWH	27	137-9185	2	Cover-Bearing
4	137-9183	2	Bearing Retainer ASM	28	133-2670	1	Transmission-Mv702
5	137-4779	4	Bearing-Ball, Custom	28:1	139-1837	1	Pulley & Fan Repair Kit
6	136-9111	2	Gear-Pinion, 15T	28:2	139-1842	1	Idler Pulley Repair Kit
7	32151-61	2	Ring-Retaining	28:2:3	139-1845	1	Spring-Tension, Belt
8	3230-23	1	Bolt-CARR	28:3	139-8974	1	Clutch Lever Repair Kit
9	136-7095	2	Cover-Wheel	29	120-7950	2	Screw-Torx
10	133-8104-03	1	Bracket-Transmission, Front	30	36-4780	2	Washer-Plain
11	3230-4	2	Bolt-CARR	31	3296-47	1	Nut-Lock,NI
12	121-2368	1	Spring-Torsion	32	138-5394-03	1	Bracket-Mount, Brake
13	104-8301	2	Nut-HF, NI	33	138-5398	1	Caliper-Brake, Disc
14	125-2540	1	Washer-Plain	33:1	139-8999	2	Pad-Brake, Disc ●
15	137-9174	2	10.5 In. Wheel ASM	34	32144-4	2	Screw-HWH
17	121-2397	1	Bracket	35	139-8990	1	Hub-Rotor
18	139-8967	1	Rear Axle ASM	36	933156	1	Pin-Roll
19	116-7127	1	Decal-HOC, Rear	37	138-5396	1	Disc-Rotor
20	52-2860	1	Washer	38	139-8960	3	Screw-Torx PH Thd Roll
21	119-2267	1	Screw-Shoulder, BHTF	39	609471	1	Screw
22	120-9471	1	Bolt-Shoulder	40	49-2040	2	Screw-HWHTF
23	139-1737	1	Lock-Height, Adj	41	140-1262-01	1	Bracket-Support, Cable
24	138-5393	1	Spring-Extension				

● Not illustrated

Handle Assembly

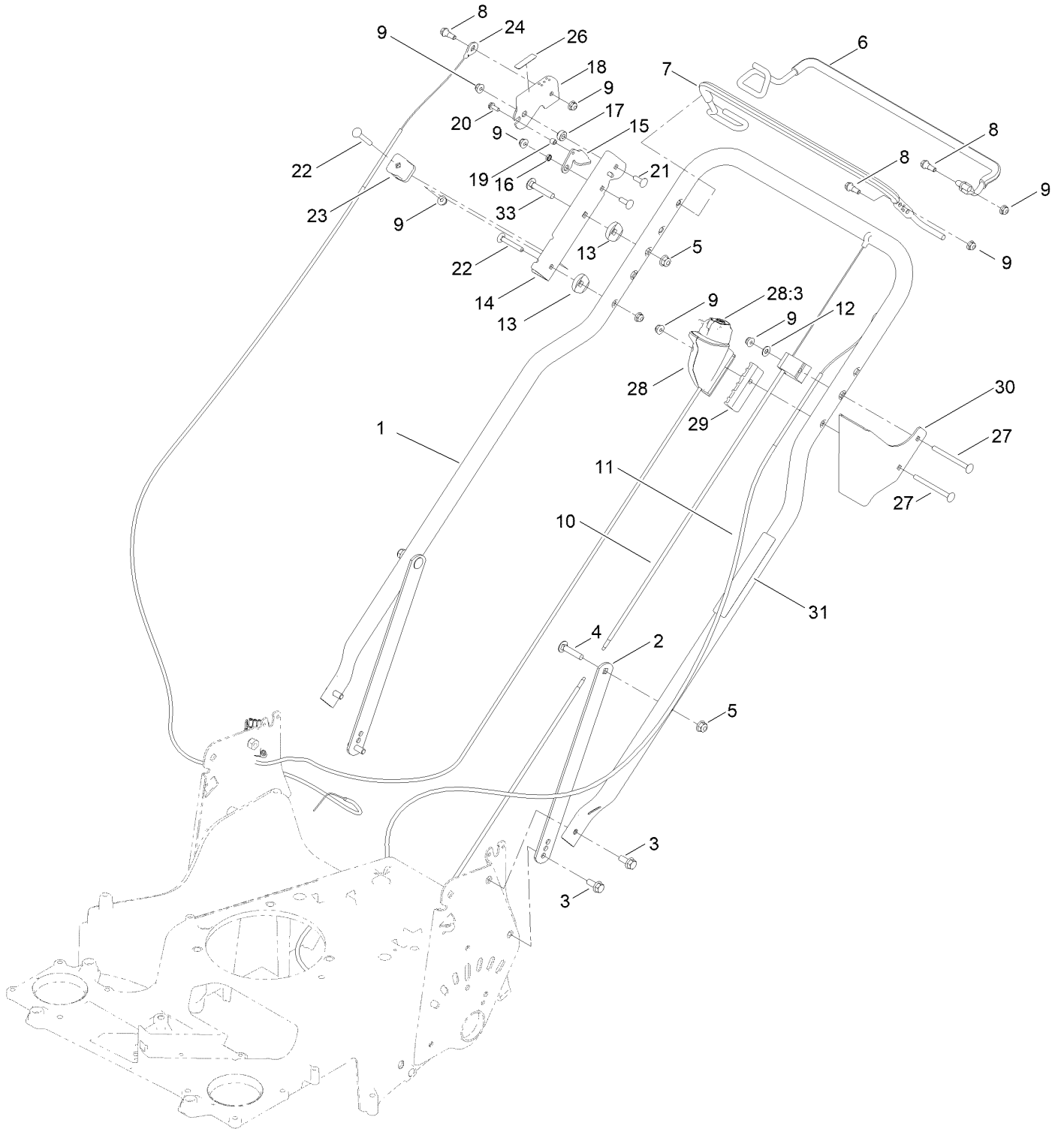

Handle Assembly (continued)

<i>Ref.</i>	<i>Part Number</i>	<i>Qty.</i>	<i>Description</i>	<i>Ref.</i>	<i>Part Number</i>	<i>Qty.</i>	<i>Description</i>
1	147-0540-03	1	Handle	17	139-1817	1	Washer-Stepped
2	116-8208-03	2	Support-Handle	18	139-1819	1	Lever-Brake
3	116-7230	4	Screw-HHF	19	117-9965	1	Spacer
4	3230-4	2	Bolt-CARR	20	32144-1	1	Screw-Taptite
5	104-8300	3	Nut-HF, NI	21	1-807512	2	Bolt-CARR
6	139-1815	1	Bail-Traction, Coated	22	3229-5	2	Screw-CARR
7	137-4810	1	Bail-BBC, Coated	23	106-6801	1	Anchor-Cable
8	42-3560	3	Bolt-Shoulder	24	138-5399	1	Cable-Brake, Parking
9	104-7201	9	Nut-HF, NI	26	139-5405	1	Decal-Brake, Parking
10	147-0488	1	Cable-Brake	27	144-6387	2	Screw-CARR,Spcl
11	147-0489	1	Cable-Traction	28	145-4008	1	Switch-Starter ASM
12	3256-1	1	Washer-Flat	28:3	147-0576	1	Starter Button Service ASM
13	106-7260	2	Washer-Curved	29	140-4148	1	Spacer-Housing, Switch
14	139-1818-03	1	Mount-Lever, Brake	30	147-0487-03	1	Guard-Switch [black]
15	139-1813	1	Link-Actuation, Brake	31	144-3175	1	Decal-Controls (60V Start)
16	138-5368	1	Spacer	33	3230-5	1	Bolt-CARR

Attachments and Accessories

For 22232 eTurfmaster 30in 60V Lawn Mower

Product Name	Model/Part
Mulching Kit	125-5064
Atomic Blade 15.4in	120-9500-03
Idler Pulley Kit.....	126-7890
60V LI-ION Battery 6.0 AH.....	88660
60V LI-ION Battery 7.5 AH.....	88675
60V Rapid Battery Charger 5.4 AMP	88605
60V LI-ION Battery 10.0 AH	66810

Notes:

Notes:

Notes:



Count on it.