



GrandStand® Revolution Mower

For All GrandStand® Revolution Mowers

Setup Instructions

Setup

Loose Parts

Use the chart below to verify that all parts have been shipped.

Procedure	Description	Qty.	Use
1	No parts required	–	Check the tire pressure.
2	No parts required	–	Check the grass deflector.
3	Battery charger	1	Charge the batteries.
4	No parts required	–	Check for firmware updates.
5	No parts required	–	Check the machine before delivery to the customer.
6	Operator's Manual Registration card Key	1 1 2	Deliver the machine to the customer.

1

Checking the Tire Pressure

No Parts Required

Procedure

Maintain the air pressure in the rear tires at 83 to 97 kPa (12 to 14 psi).

Important: Uneven tire pressure can cause an uneven cut.

Note: The front tires are semi-pneumatic tires and do not require air-pressure maintenance.

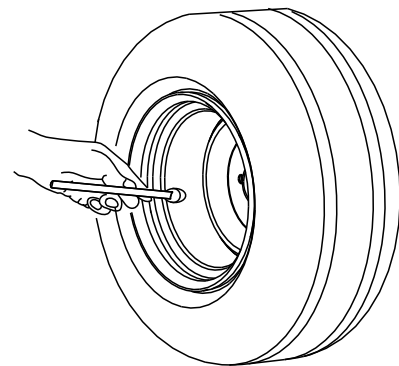

G001055

g001055

Figure 1



2

Checking the Grass Deflector

No Parts Required

Procedure

⚠ DANGER

An uncovered discharge opening allows objects to be thrown toward you or bystanders. Also, contact with the blade could occur. Thrown objects or blade contact will cause serious injury or death.

Do not operate the mower with the discharge deflector raised, removed, or altered unless a grass collection system or mulch kit is in place and working properly.

1. If there are plastic ties holding the grass deflector up, remove them and lower the deflector into the operating position.
2. Ensure that 1 end of the spring is installed behind the deck edge and the other end is installed around the grass deflector as shown in [Figure 2](#).

Important: The grass deflector must be free to rotate with downward tension. Lift the deflector up to the fully open position and ensure that it rotates freely, without binding into the fully down position.

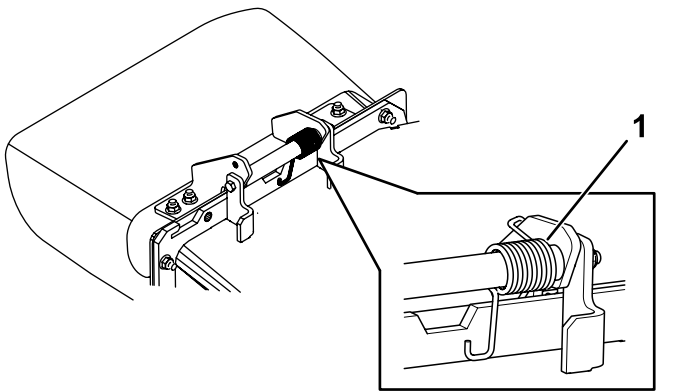

Figure 2

1. Spring

3

Charging the Batteries

Parts needed for this procedure:

1	Battery charger
---	-----------------

Procedure

Charge the batteries per the instructions in the *Operator's Manual* for the machine.

4

Checking for Firmware Updates

No Parts Required

Procedure

Connect the machine to Toro DIAG software and check for firmware updates for the machine; update the firmware as needed.

5

Checking the Machine Before Delivery to the Customer

No Parts Required

Procedure

Before delivering the machine to the customer, ensure that you perform or have performed the procedures listed in the following table and initial each when finished. Refer to the *Operator's Manual* for instructions on performing these procedures.

Initial	Check Procedure
	Check the tire pressure.
	Check the level of the machine.
	Ensure that the machine tracks correctly; refer to the <i>Operator's Manual</i> for the adjustment procedure.
	Check the safety-interlock system; refer to the <i>Operator's Manual</i> .
	Ensure that the PTO works.
	Check all fasteners that you installed to ensure that they are tight.

When you finish setting up the machine, sign and date in the space provided below:

Signature: _____ Date: _____

6

Delivering the Machine to the Customer

Parts needed for this procedure:

1	<i>Operator's Manual</i>
1	Registration card
2	Key

Procedure

At delivery, fill in the model and serial number, complete the items listed in the following table, and initial each when finished.

Model No. _____ Serial No. _____

Dealer Initial	Customer Initial	Check Procedure
		Show the customer where the following features are located and how they function: <ul style="list-style-type: none"> • Battery-disconnect switch • Transmission disengage • Battery-charger connector • InfoCenter • Key switch • Power-takeoff switch (PTO) • Motion-control levers • Mower height-of-cut
		Refer to the <i>Operator's Manual</i> to point out safety procedures, operation, and maintenance procedures.
		Review the warranty statement as shown in the <i>Warranty</i> .
		Describe the post sale service procedures for your store.
		Assist the customer in filling out and mailing the registration card or register online at www.Toro.com .
		Make sure that the customer receives the <i>Operator's Manual</i> and <i>Setup Instructions</i> .
		Make sure that the customer knows the <i>Parts Catalog</i> and operator-training materials are available at www.Toro.com .
		Assist the customer in loading the machine.

Note: When you, the dealer representative, have finished delivering the machine to the customer, sign and date in the space provided below and keep a copy of this page for dealer records. Also, the dealer must remind the customer to use a full-width trailer ramp to load the machine.

Signature: _____ **Date:** _____

Signature: _____ **Date:** _____