



Count on it.

Operator's Manual

Workman® GTX Lithium Utility Vehicle

Model No. 07413LT—Serial No. 414318861 and Up

Model No. 07413TC—Serial No. 414400000 and Up

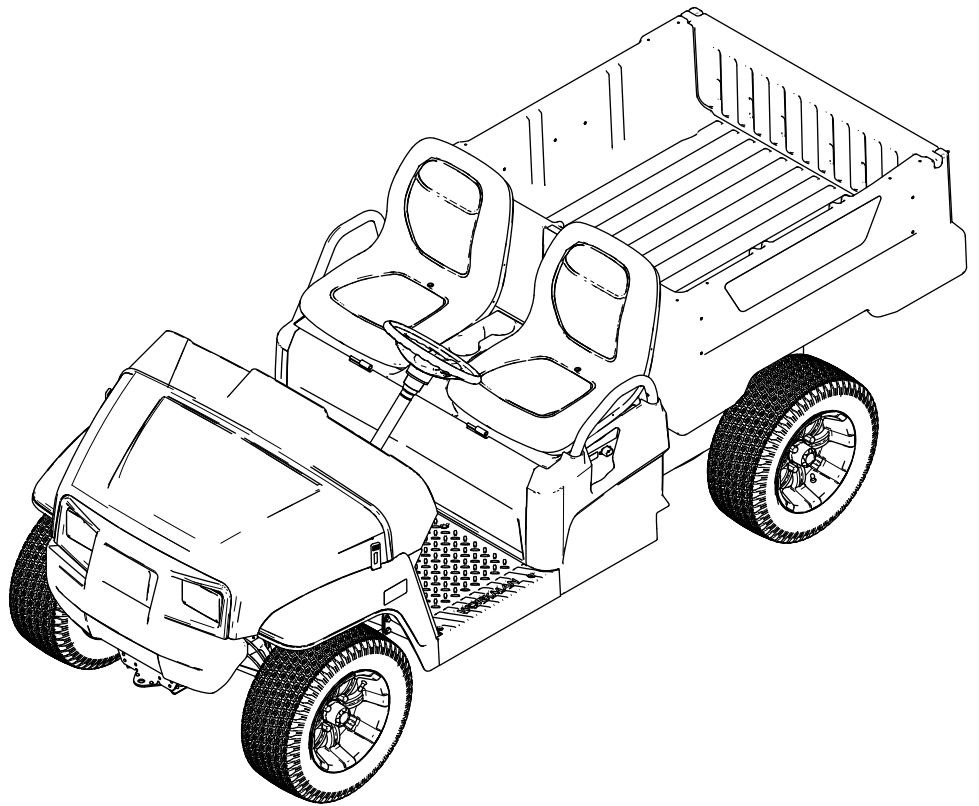

This product complies with all relevant European directives; for details, please see the separate product specific Declaration of Conformity (DOC) sheet.

⚠ WARNING

CALIFORNIA Proposition 65 Warning

The power cord on this product contains lead, a chemical known to the State of California to cause birth defects or other reproductive harm. Wash hands after handling.

Battery posts, terminals, and related accessories contain lead and lead compounds, chemicals known to the State of California to cause cancer and reproductive harm. Wash hands after handling.

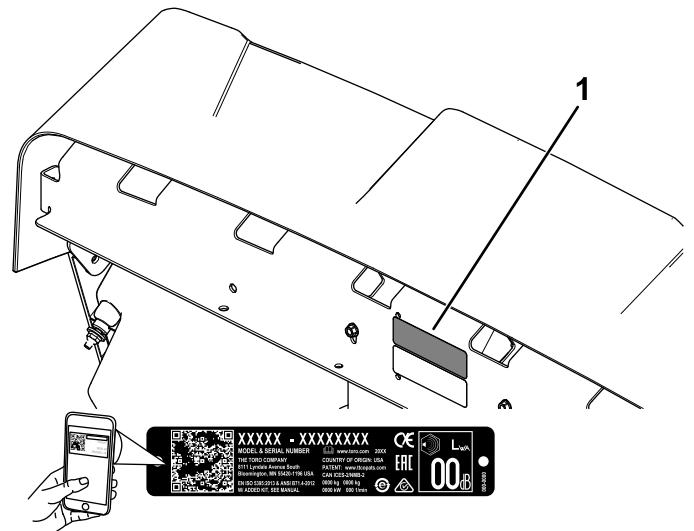

Figure 1

1. Model and serial number location

g282597

Model No. _____

Serial No. _____

Introduction

This utility vehicle is intended to be primarily used off-highway to transport people and material loads. Using this product for purposes other than its intended use could prove dangerous to you and bystanders.

Read this information carefully to learn how to operate and maintain your product properly and to avoid injury and product damage. You are responsible for operating the product properly and safely.

Visit www.Toro.com for product safety and operation training materials, accessory information, help finding a dealer, or to register your product.

Whenever you need service, genuine Toro parts, or additional information, contact an Authorized Service Distributor or Toro Customer Service and have the model and serial numbers of your product ready. [Figure 1](#) identifies the location of the model and serial numbers on the product. Write the numbers in the space provided.

Important: With your mobile device, you can scan the QR code on the serial number decal (if equipped) to access warranty, parts, and other product information.

This manual uses 2 words to highlight information. **Important** calls attention to special mechanical information and **Note** emphasizes general information worthy of special attention.

The safety-alert symbol ([Figure 2](#)) appears both in this manual and on the machine to identify important safety messages that you must follow to avoid accidents. This symbol will appear with the word **Danger**, **Warning**, or **Caution**.

- **Danger** indicates an imminently hazardous situation which, if not avoided, **will** result in death or serious injury.
- **Warning** indicates a potentially hazardous situation which, if not avoided, **could** result in death or serious injury.
- **Caution** indicates a potentially hazardous situation which, if not avoided, **may** result in minor or moderate injury.



Figure 2

Safety-alert symbol

g000502

Contents

Safety	4	Disconnecting the Batteries	37
General Safety	4	Connecting the Batteries	37
Safety and Instructional Decals	5	Replacing a Fuse.....	38
Setup	7	Maintaining the Headlights	39
1 Installing the Steering Wheel.....	7	Servicing the Batteries.....	40
2 Checking the Fluid Levels and Tire		Maintaining the Battery Charger	40
Pressure	8	Drive System Maintenance	40
3 Burnishing the Brakes.....	8	Maintaining the Tires	40
4 Reading the Manual and Viewing the		Inspecting the Steering and Suspension	
Setup Material.....	8	Components	41
Product Overview	9	Adjusting the Front Wheel Alignment	41
Controls	10	Checking the Transaxle-Fluid Level	42
Display.....	12	Changing the Transaxle Fluid	43
Specifications	15	Brake Maintenance	43
Attachments/Accessories	15	Checking the Parking Brake	43
Before Operation	16	Adjusting the Parking Brake.....	43
Before Operation Safety	16	Checking the Brake-Fluid Level	44
Performing Daily Maintenance.....	16	Inspecting the Brakes	44
Checking the Tire Pressure.....	16	Replacing the Service and Parking-Brake	
Breaking in a New Machine	17	Pads.....	45
During Operation	17	Changing the Brake Fluid	45
During Operation Safety	17	Chassis Maintenance.....	45
Operating the Cargo Bed	19	Adjusting the Cargo-Bed Latches	45
Monitoring the Battery-System Charge		Cleaning	46
Level	21	Washing the Machine	46
Stopping the Machine	21	Storage	47
Loading the Cargo Bed	22	Storage Safety.....	47
After Operation	23	Storing the Machine.....	47
After Operation Safety	23	Battery Storage Requirements	48
Hauling the Machine	24	Troubleshooting	49
Towing the Machine.....	25		
Towing a Trailer	25		
Maintaining the Lithium-Ion Batteries.....	26		
Transporting the Lithium-Ion Batteries	26		
Understanding the Lithium-Ion Battery			
Charger.....	27		
Maintenance	28		
Maintenance Safety.....	28		
Recommended Maintenance Schedule(s)	28		
Daily Maintenance Checklist.....	29		
Maintaining the Machine under Special			
Operating Conditions	30		
Pre-Maintenance Procedures	30		
Preparing the Machine for Maintenance.....	30		
Lifting the Machine	31		
Accessing the Hood.....	31		
Raising and Lowering the Seat			
Assembly	32		
Removing a Bucket Seat	32		
Installing a Bucket Seat	32		
Removing a Bench Cushion	32		
Installing a Bench Cushion	33		
Lubrication	33		
Greasing the Front Wheel Bearings	33		
Electrical System Maintenance	37		
Electrical System Safety	37		

Safety

This machine has been designed in accordance with the requirements of SAE J2258 (Nov 2016).

General Safety

This product is capable of causing personal injury. Always follow all safety instructions to avoid serious personal injury.

- Read and understand the contents of this *Operator's Manual* before you start the machine. Ensure that everyone using this product knows how to use it and understands the warnings.
- Use your full attention while operating the machine. Do not engage in any activity that causes distractions; otherwise, injury or property damage may occur.
- Do not put your hands or feet near moving components of the machine.
- Do not operate the machine without all guards and other safety protective devices in place and working on the machine.
- Keep bystanders and children out of the operating area. Never allow children to operate the machine.
- Stop and shut off the machine and remove the key before servicing.

Improperly using or maintaining this machine can result in injury. To reduce the potential for injury, comply with these safety instructions and always pay attention to the safety-alert symbol ▲, which means Caution, Warning, or Danger—personal safety instruction. Failure to comply with these instructions may result in personal injury or death.

Safety and Instructional Decals



Safety decals and instructions are easily visible to the operator and are located near any area of potential danger. Replace any decal that is damaged or missing.

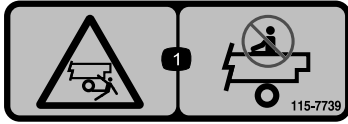

115-7739

decal115-7739

1. Falling, crushing hazard—do not carry passengers.

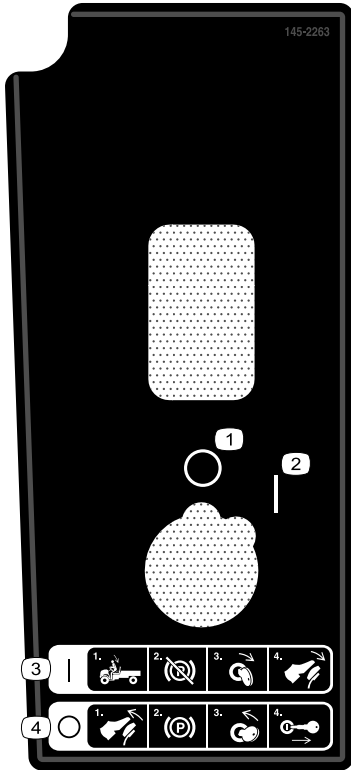

145-2263

decal145-2263

1. Off
2. On
3. To start the machine: 1) Sit in the operator's position; 2) Disengage the parking brake; 3) Turn the key to the ON position; 4) Press the accelerator pedal.
4. To shut off the machine: 1) Release the accelerator pedal; 2) Engage the parking brake; 3) Turn the key to the OFF position; 4) Remove the key.

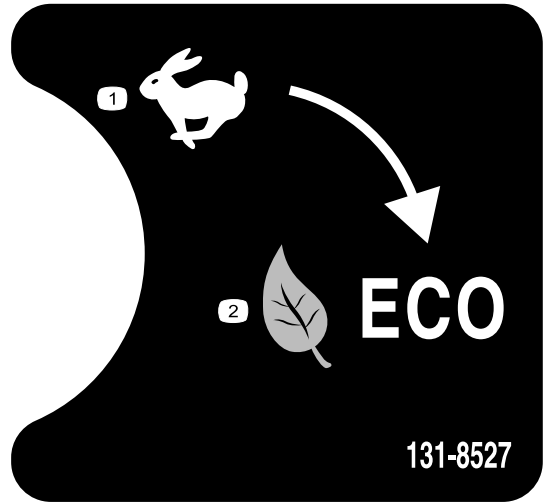

131-8527

decal131-8527

1. Performance mode
2. Eco mode

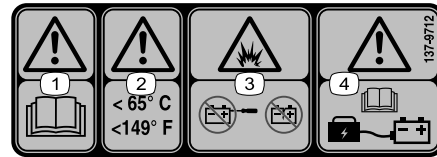

137-9712

decal137-9712

1. Warning—read the *Operator's Manual*.
2. Warning—keep at temperatures below 65° C (149° F).
3. Explosion hazard—do not open the battery; do not use a damaged battery.
4. Warning—read the *Operator's Manual* for battery charging information.

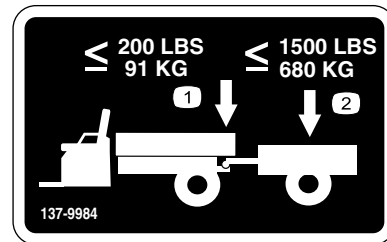

137-9984

decal137-9984

1. Do not exceed a tongue weight of 91 kg (200 lb).
2. Do not exceed a transport load of 680 kg (1,500 lb).

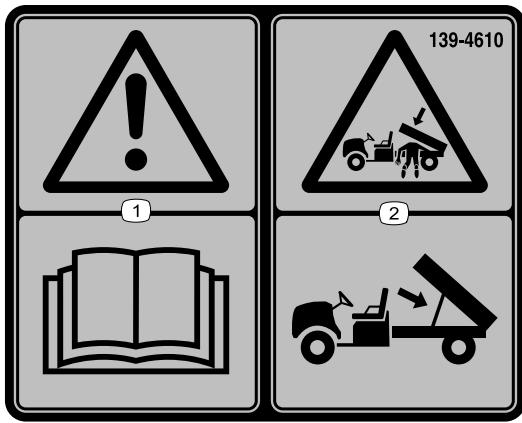

139-4610

decal139-4610

1. Warning—read the *Operator's Manual*.
2. Crushing hazard, cargo box—use the prop rod to support the cargo bed.

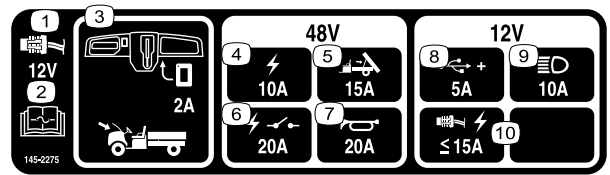

decal145-2275

145-2275

1. 12 V plug
2. Read the *Operator's Manual* for fuse information.
3. Display (2 A); fuse located under the hood.
4. Power (10 A)
5. Bed lift (15 A)
6. Electric relay (20 A)
7. Horn (20 A)
8. USB power point (5 A)
9. Headlights (10 A)
10. Electric power (less than or equal to 15 A)

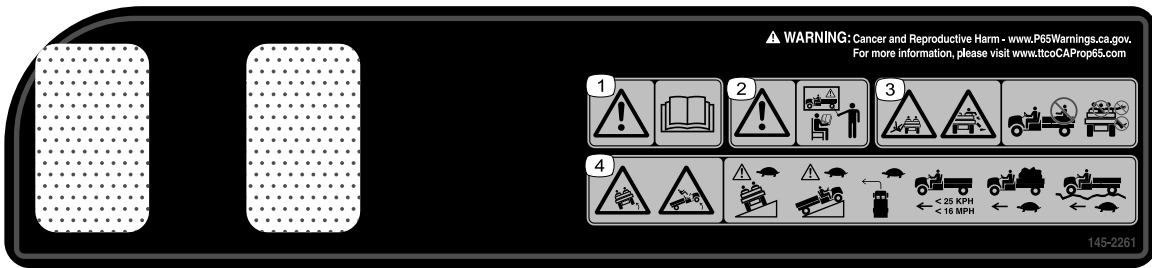

decal145-2261

145-2261

1. Warning—read the *Operator's Manual*.
2. Warning—receive proper training before operating the machine.
3. Falling hazard; severing hazard of limbs—do not carry passengers in the bed; do not carry extra passengers in between the seats; do not put your arms or legs outside of the machine while operating.
4. Tipping hazard—drive slowly across or up slopes; take turns slowly; do not exceed speeds of 25 kph (16 mph); drive slowly when hauling cargo; drive slowly on uneven terrain.

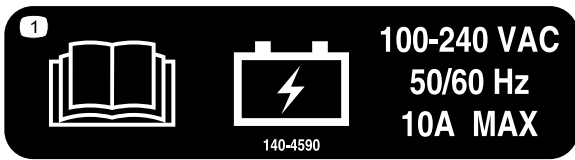

140-4590

decal140-4590

1. Read the *Operator's Manual* for battery information.

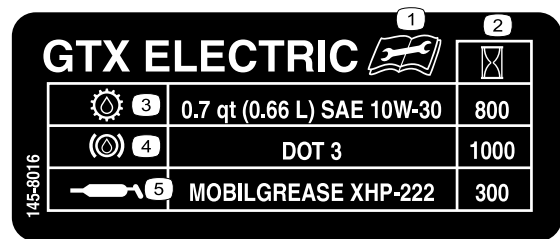

decal145-8016

145-8016

1. Read the *Operator's Manual* before performing maintenance.
2. Service interval (hours)
3. Transaxle fluid
4. Brake fluid
5. Grease points

Setup

Loose Parts

Use the chart below to verify that all parts have been shipped.

Procedure	Description	Qty.	Use
1	Steering wheel	1	Install the steering wheel (international models only).
	Locknut	1	
	Wheel cover	1	
	Screw	3	
2	No parts required	–	Check the fluid levels and tire pressure.
3	No parts required	–	Burnish (break-in) the brakes.
4	Operator's Manual	1	Read the Operator's Manual and view the setup material before operating the machine.
	Registration card	1	
	Predelivery Inspection Form	1	
	Certificate of Quality	1	
	Key	2	

Note: Determine the left and right sides of the machine from the normal operating position.

1

Installing the Steering Wheel

International Models Only

Parts needed for this procedure:

1	Steering wheel
1	Locknut
1	Wheel cover
3	Screw

Procedure

- Place the steering wheel on the steering shaft.
Ensure that the steering wheel is centered (i.e., the flat bottom should be parallel with the ground).
- Use the locknut to secure the steering wheel to the steering shaft.
- Torque the locknut to 27 N·m (20 ft-lb).

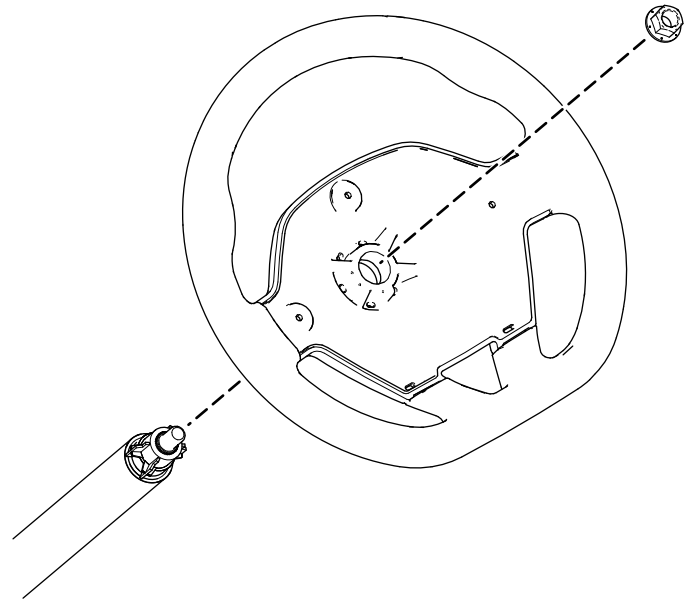

Figure 3

g424446

4. Use 3 screws to secure the wheel cover to the steering wheel.
5. Torque the 3 screws to 0.6 N·m (5 in-lb).

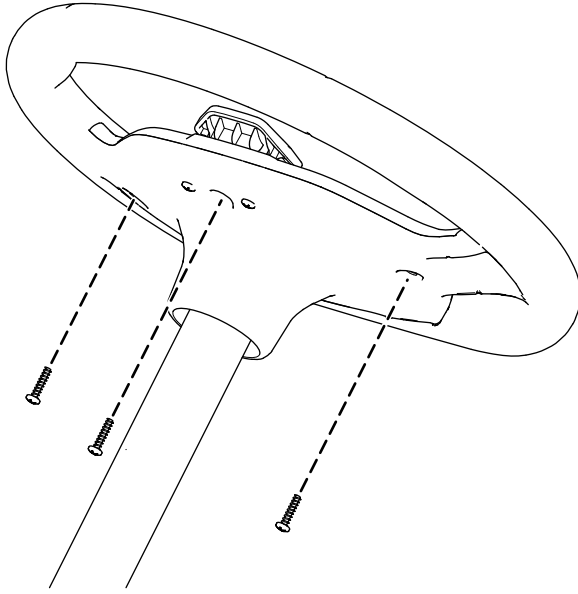

Figure 4

g424447

3

Burnishing the Brakes

No Parts Required

Procedure

To ensure optimum performance of the brake system, burnish (break-in) the brakes before use.

1. Bring the machine up to full speed, apply the brakes to rapidly stop the machine without locking up the tires.
2. Repeat this procedure 10 times, waiting 1 minute between stops, to avoid overheating the brakes.

Important: This procedure is most effective if the machine is loaded with 227 kg (500 lb).

4

Reading the Manual and Viewing the Setup Material

Parts needed for this procedure:

1	<i>Operator's Manual</i>
1	Registration card
1	<i>Predelivery Inspection Form</i>
1	Certificate of Quality
2	Key

Procedure

- Read the *Operator's Manual*.
- Fill out the registration card.
- Complete the *Predelivery Inspection Form*.
- Review the *Certificate of Quality*.

2

Checking the Fluid Levels and Tire Pressure

No Parts Required

Procedure

1. Ensure that the batteries are charged; refer to [Charging the Lithium-Ion Batteries \(page 27\)](#).
2. Check the brake-fluid level before you operate the machine; refer to [Checking the Brake-Fluid Level \(page 44\)](#).
3. Check the air pressure in the tires; refer to [Checking the Tire Pressure \(page 16\)](#).

Product Overview

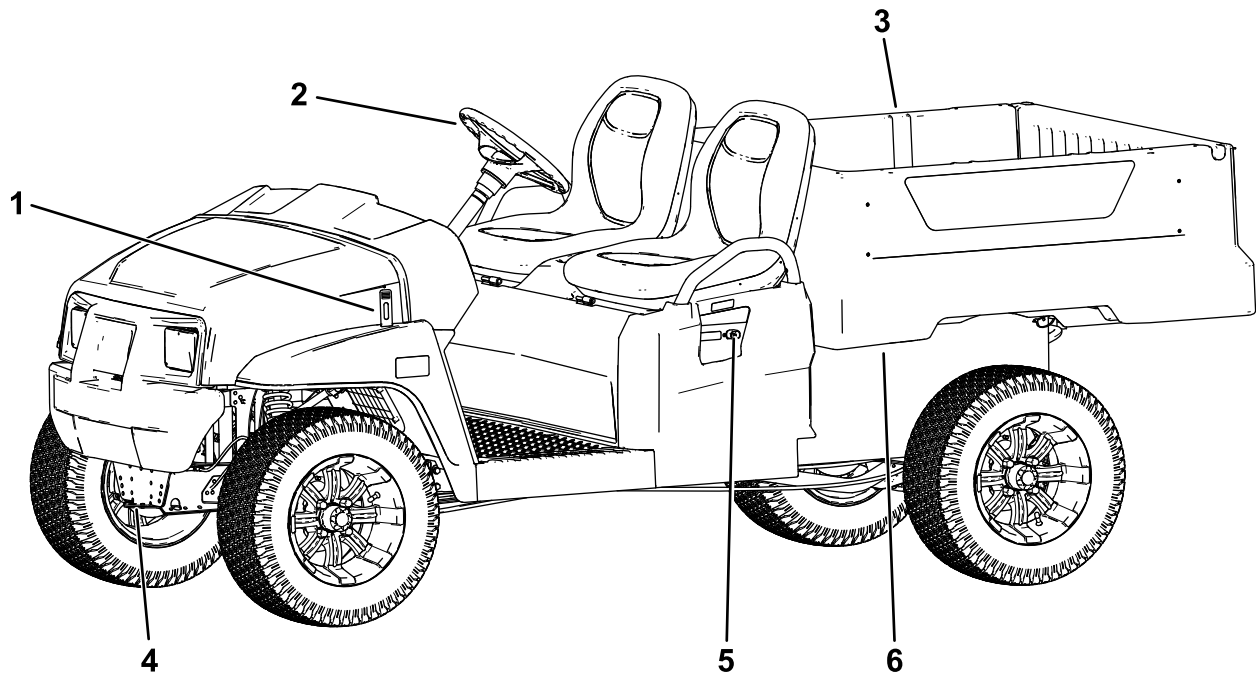

Figure 5

g319171

- | | | |
|-------------------|------------------|--------------------|
| 1. Hood latch | 3. Cargo bed | 5. Battery charger |
| 2. Steering wheel | 4. Towing tongue | 6. Cargo-bed lever |

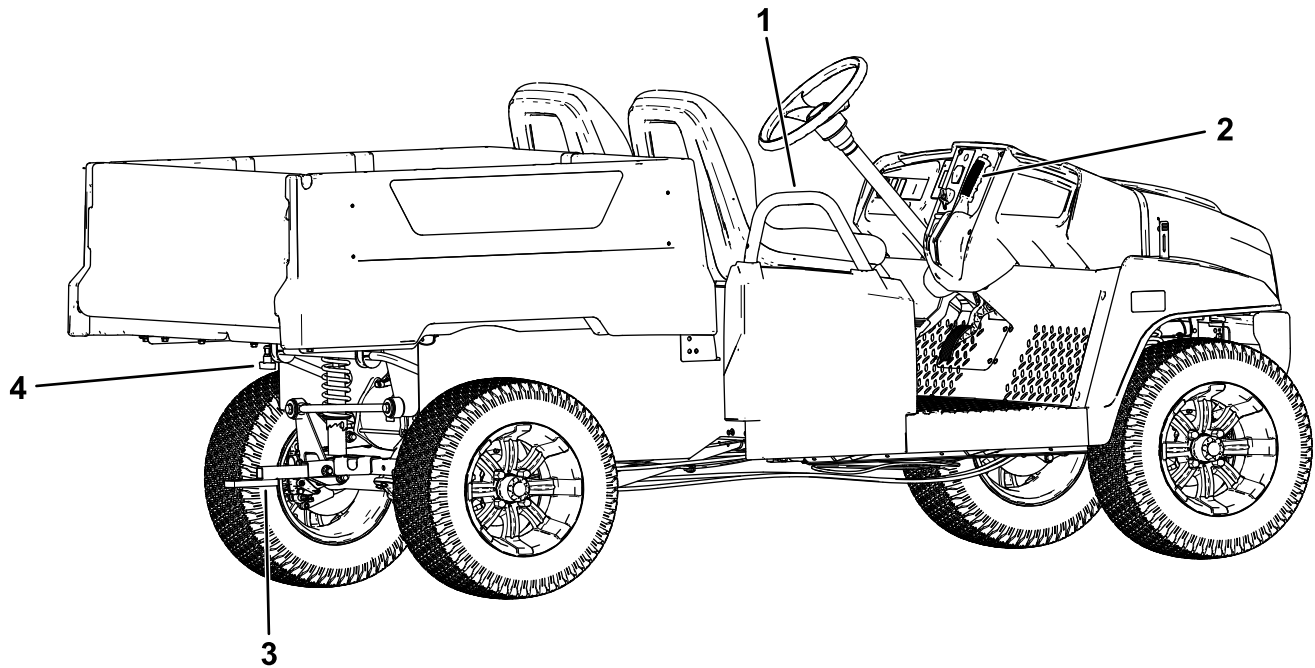

Figure 6

g319172

- | | |
|------------------------|-----------------------------------|
| 1. Passenger handhold | 3. Trailer hitch |
| 2. Parking-brake lever | 4. Rear cargo-bed-accessory mount |

Controls

Control Panel

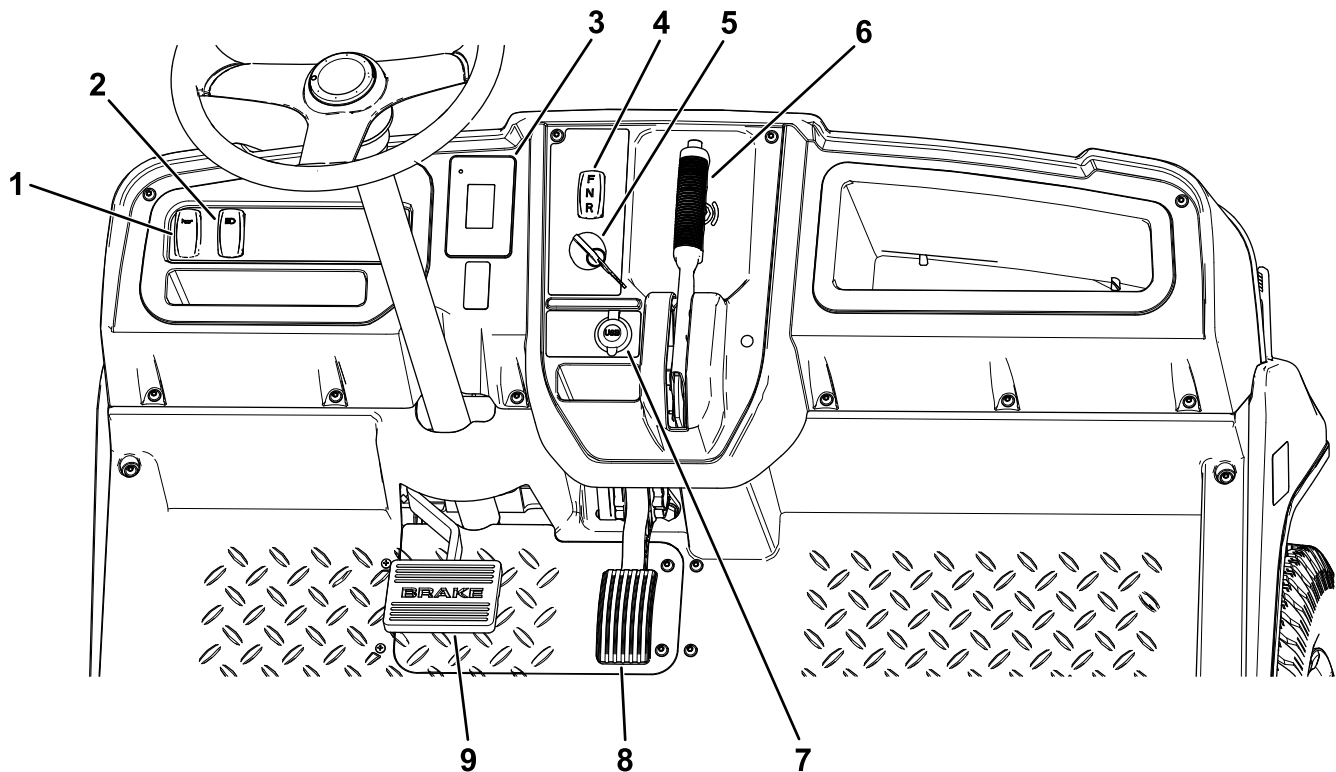

Figure 7

g377919

- | | |
|------------------------|------------------------|
| 1. Horn switch | 6. Parking-brake lever |
| 2. Light switch | 7. USB power point |
| 3. Display | 8. Accelerator pedal |
| 4. Gear-shift selector | 9. Brake pedal |
| 5. Key switch | |

Accelerator Pedal

Use the accelerator pedal (Figure 7) to vary ground speed of the machine. Pressing down the accelerator pedal starts the machine. Pressing the pedal farther increases ground speed. Releasing the pedal slows the machine, and the machine shuts off.

The maximum forward speed in performance mode is 26 km/h (16 mph) as shown in Figure 17.

The maximum forward speed in economy mode is 19 km/h (12 mph) as shown in Figure 17.

Brake Pedal

Use the brake pedal to stop or slow the machine (Figure 7).

⚠ CAUTION

Operating a machine with worn or incorrectly adjusted brakes can may result in personal injury.

If the brake pedal travels to within 25 mm (1 inch) of the machine floor board, adjust or repair the brakes.

Parking-Brake Lever

The parking-brake lever is located on the control panel (Figure 7).

Whenever you shut off the machine, engage the parking brake to prevent the machine from accidentally moving. If the machine is parked on a steep grade, ensure that you engage the parking brake.

To engage the parking brake, pull the parking-brake lever toward you (Figure 8).

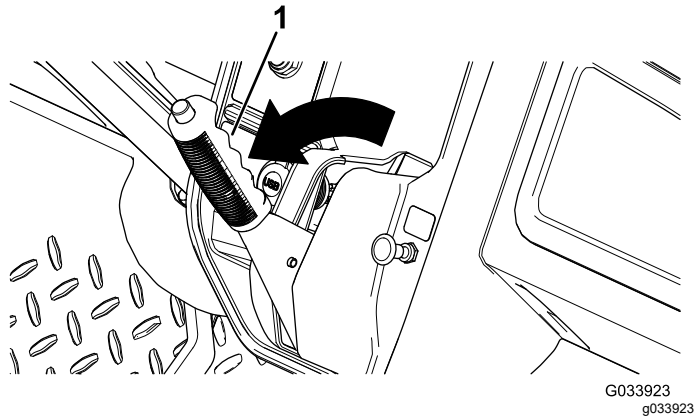

Figure 8

1. Parking-brake lever

To disengage the parking brake, push down the button on top of the parking-brake lever, pull the parking-brake lever toward you to release pressure, and then push the parking-brake lever forward (Figure 9).

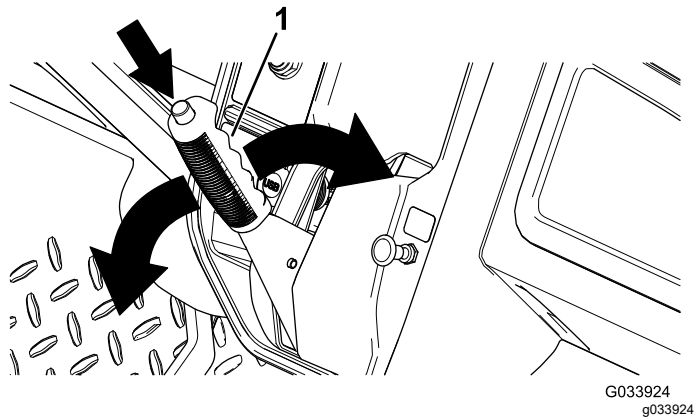

Figure 9

1. Parking-brake lever

Direction Selector

The direction selector is located to the left of the parking-brake lever. The direction selector has 3 positions: FORWARD, REVERSE, and NEUTRAL (Figure 7).

Note: The machine can be in any of the 3 positions, but only moves in the FORWARD and REVERSE positions.

Important: Always stop the machine before changing direction.

Horn Switch

The horn switch is located on the control panel (Figure 7). Press the horn switch to sound the horn.

Light Switch

Use the light switch (Figure 7) to illuminate the headlights. Push the light switch up to turn on the headlights. Push the light switch down to turn off the lights.

USB Power Point

The USB power point is located to the left of the parking-brake lever (Figure 7). Use the power point to power mobile devices.

Important: When you are not using the USB power point, insert the rubber plug to prevent damage to the power point.

Key Switch

Use the key switch (Figure 7), to run and shut off the machine.

The key switch has 2 positions: ON and OFF. Rotate the key clockwise to the ON position to operate the machine. When you stop the machine, rotate the key counterclockwise to the OFF position to shut off the machine. Remove the key whenever you leave the machine.

Display

The display shows information about your machine, such as the operating status, various diagnostics, and other information about the machine (Figure 10).

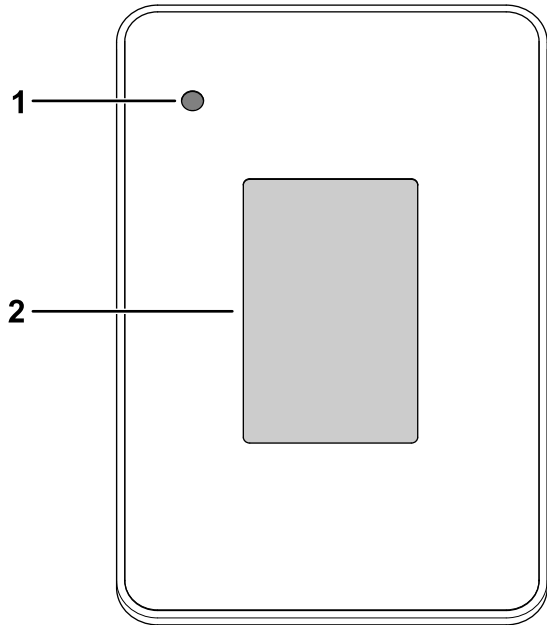

Figure 10

g320256

- 1. Indicator light
- 2. Display

There is a startup screen, run screen, and charging screen on the display (Figure 11, Figure 12, and Figure 13).

Figure 12 shows what you may see on the display when you run the machine. The startup screen displays for a few seconds after you turn the key to the ON position, then the run screen displays.

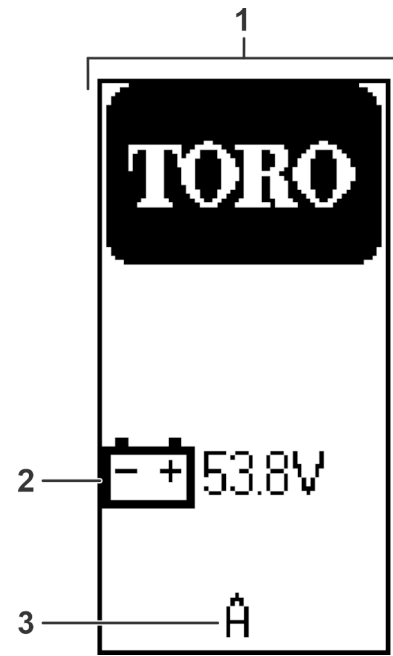

Figure 11

g321175

- 1. Startup screen
- 2. Battery voltage
- 3. Software revision

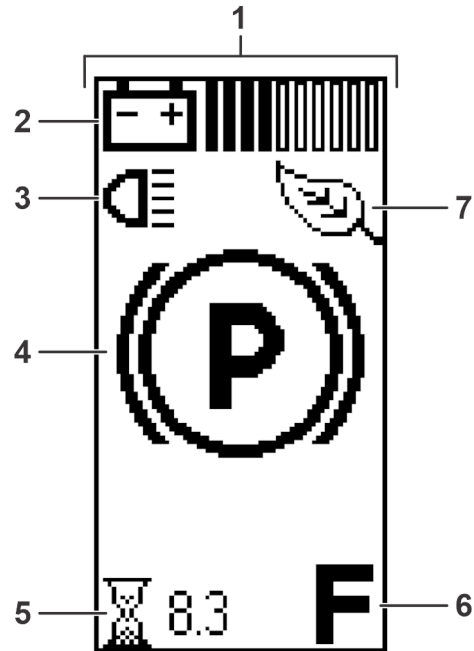

Figure 12

g321176

- 1. Run screen
- 2. Battery charge
- 3. Lights—On
- 4. Parking brake is engaged.
- 5. Hours operated
- 6. Direction
- 7. Eco Mode

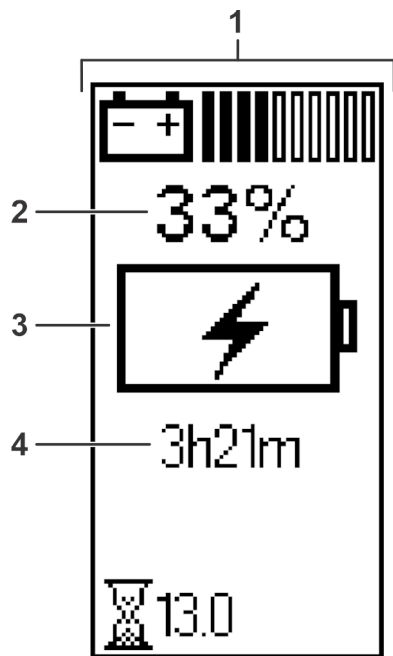

Figure 13

g321177

1. Charging screen
2. Battery life
3. Battery currently charging indicator
4. Estimated time to fully charge the machine

The run screen with the direction position (Figure 14) appears when you change directions.

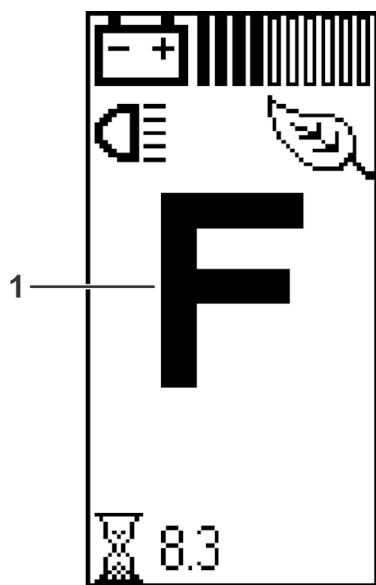

Figure 14

g321180

1. FORWARD position

The run screen with the current machine speed (Figure 15) appears when you are driving the machine.

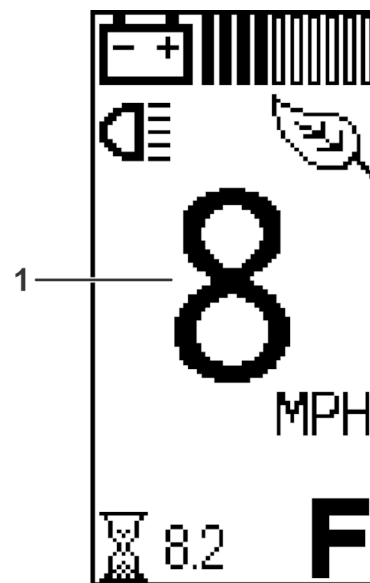

Figure 15

g321181

1. Current machine speed

An active fault code (Figure 16) appears on the display if there is an issue with the machine.

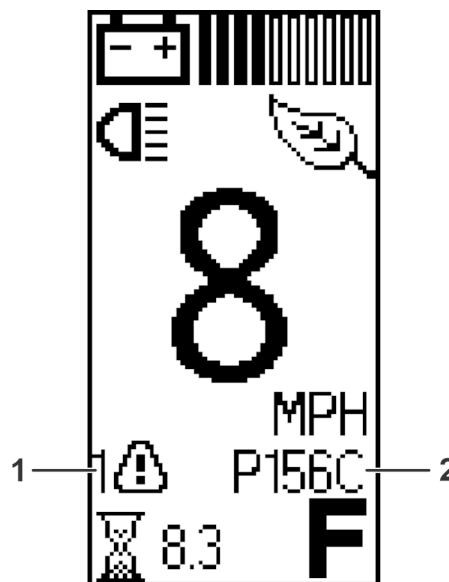









Figure 16

g321179

1. Active fault indicator
2. Fault code

Icon Descriptions

F	Direction—FORWARD position
N	Direction—NEUTRAL position
R	Direction—REVERSE position
(P)	Parking brake is engaged.
	Hour meter
	Lights—ON position
	Battery voltage
	Battery charge—each solid bar represents the charge in 10% increments.
	<ul style="list-style-type: none"> • Low-battery advisory • Battery currently charging
	Eco Mode is on.
	Active fault
	Cold start

Supervisor Speed-Limit Switch

The supervisor speed-limit switch, located under the seat assembly, has 2 positions: PERFORMANCE and ECONOMY. Rotate the switch clockwise to the ECONOMY position to limit the maximum machine speed to 19 km/h (12 mph). Rotate the switch counterclockwise to the PERFORMANCE position to restore the maximum speed of the machine to 26 km/h (16 mph) as shown in [Figure 17](#).

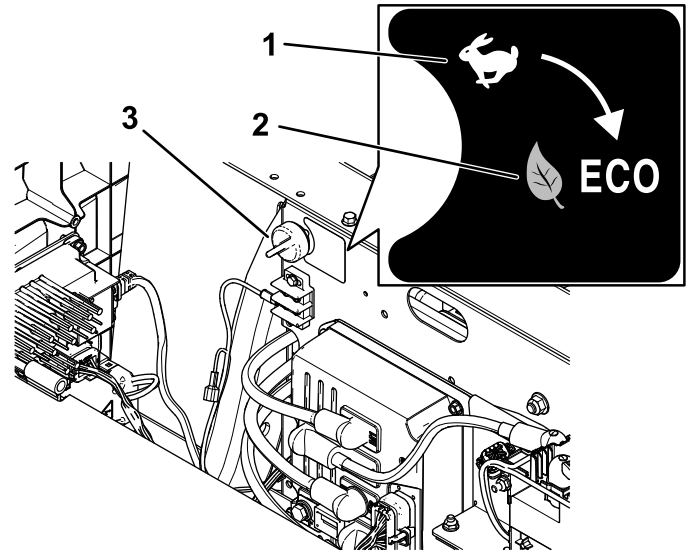

Figure 17

1. PERFORMANCE position
2. ECONOMY position
3. Supervisor speed-limit switch

Passenger Handholds

The passenger handholds are located on the outside of each seat ([Figure 18](#)).

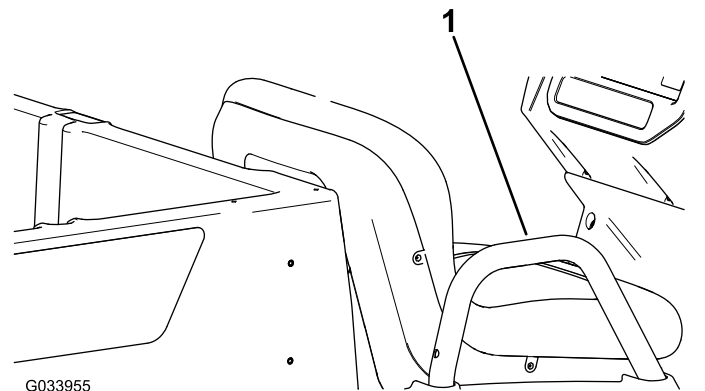

Figure 18
Passenger Side Shown

1. Passenger handhold

Specifications

Note: Specifications and design are subject to change without notice.

Base weight	Dry 456 kg (1,005 lb)
Rated capacity (on level ground)	544 kg (1,200 lb) total, including 91 kg (200 lb) operator and 91 kg (200 lb) passenger, load, accessories, and attachments
Gross vehicle weight (GVW)—on level ground	1000 kg (2,205 lb) total, including all of the weights listed above
Maximum cargo capacity (on level ground)	363 kg (800 lb) total, including rear-mounted accessories
Maximum rear cargo bed accessory mount capacity	45 kg (100 lb) total
Tow capacity	Tongue weight: 91 kg (200 lb) Gross trailer weight (GTW): 680 kg (1,500 lb)
Overall width	119 cm (47 inches)
Overall length	302 cm (119 inches)
Overall height	127.5 cm (50-3/16 inches)
Ground clearance	21.6 cm (8-1/2 inches) at the front with no load or operator 14 cm (5-1/2 inch) at the rear with no load or operator
Wheel base	220 cm (86-5/8 inches)
Wheel tread (center line to center line)	Front: 119 cm (47 inches) Rear: 119 cm (47 inches)
Cargo bed length	Inside: 102 cm (40 inches) Outside: 114.3 cm (45 inches)
Cargo bed width	Inside: 98 cm (38-1/2 inches) Outside of the molded fenders: 107.3 cm (42-5/16 inches)
Cargo bed height	28 cm (11 inches) inside

Attachments/Accessories

A selection of Toro approved attachments and accessories is available for use with the machine to enhance and expand its capabilities. Contact your Authorized Service Dealer or authorized Toro distributor or go to www.Toro.com for a list of all approved attachments and accessories.

To ensure optimum performance and continued safety certification of the machine, use only genuine Toro replacement parts and accessories. Replacement parts and accessories made by other manufacturers could be dangerous, and such use could void the product warranty.

Operation

Note: The procedures in this section show a machine with a plastic cargo bed and bucket seat; for additional procedures for other attachments, refer to the Operation section (if applicable) in the Installation Instructions. Visit www.Toro.com for your instructions or scan the QR code (if applicable) on your attachment.

Before Operation

Before Operation Safety

General Safety

- Never allow children or people who are not trained or physically capable to safely operate or service the machine. Local regulations may restrict the age of the operator. The owner is responsible for training all operators and mechanics.
- Become familiar with the safe operation of the equipment, operator controls, and safety signs.
- Shut off the machine, remove the key, and wait for all movement to stop before you leave the operator's position. Allow the machine to cool before adjusting, servicing, cleaning, or storing it.
- Know how to stop and shut off the machine quickly.
- Ensure that there are not more occupants (you and your passenger(s)) than the number of handholds equipped on the machine.
- Check that all safety devices and decals are in place. Repair or replace all safety devices and replace all illegible or missing decals. Do not operate the machine unless they are present and functioning properly.

Performing Daily Maintenance

Service Interval: Before each use or daily

Before starting the machine each day, perform the Each Use/Daily procedures listed in [Maintenance \(page 28\)](#).

Checking the Tire Pressure

Service Interval: Before each use or daily

Front and rear tires air pressure specification: 165 to 207 kPa (24 to 30 psi)

Important: Do not exceed the maximum air pressure indicated on the sidewall of the tire.

Note: The air pressure needed in the tires is determined by the payload that you intend to carry.

1. Check the air pressure in the tires.
 - Use lower air pressure in the tires for lighter payloads, for less soil compaction, for a smoother ride, and to minimize tire marks on the ground.
 - Use higher air pressure in the tires for carrying heavier payloads at higher speeds.
2. If necessary, adjust the air pressure in the tires by adding or removing air in the tires.

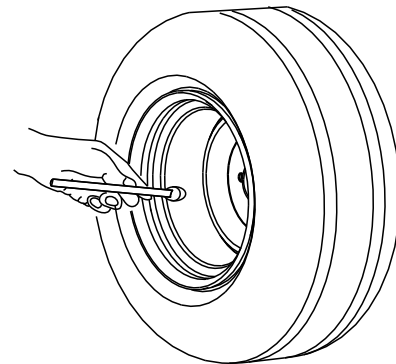

G001055

Figure 19

g001055

Breaking in a New Machine

Service Interval: After the first 100 hours—Perform the breaking in a new machine guidelines.

Perform the breaking in a new machine guidelines to provide proper performance and long life for the machine.

- Check the brake fluid.
- Avoid hard braking situations for the first several hours of new machine break-in operation. New brake linings may not be at optimum performance until several hours of use has caused the brakes to become burnished (broken-in).
- Refer to [Maintenance \(page 28\)](#) for any special low hour checks.
- Check the front suspension positioning and adjust it, if necessary; refer to [Adjusting the Front Wheel Alignment \(page 41\)](#).
- For optimal battery performance and battery life, perform the following battery break-in process:
 1. Charge the batteries to 100% when you receive your machine.
 2. Run the machine until the display shows the low-battery advisory (approximately 5%), then fully charge the batteries to 100%.
Repeat this step 4 times to optimize battery performance.

During Operation

During Operation Safety

General Safety

- The owner/operator can prevent and is responsible for accidents that may cause personal injury or property damage.
- Passengers should sit in the designated seating positions only. Do not carry passengers in the cargo bed. Keep bystanders and pets away from the machine during operation.
- Wear appropriate clothing, including eye protection; long pants; substantial, and slip-resistant footwear. Tie back long hair and do not wear loose clothing or loose jewelry.
- Use your full attention while operating the machine. Do not engage in any activity that causes distractions; otherwise, injury or property damage may occur.
- Do not operate the machine while ill, tired, or under the influence of alcohol or drugs.
- Do not exceed the maximum gross vehicle weight (GVW) of the machine.
- Use extra caution when operating, braking, or turning the machine with a heavy load in the cargo bed.
- Carrying oversized loads in the cargo bed reduces the stability of the machine. Do not exceed the carrying capacity of the bed.
- Carrying material that cannot be bound to the machine adversely affects the steering, braking, and stability of the machine. When you carry material that cannot be bound to the machine, use caution when steering or braking.
- Carry a reduced load and reduce the ground speed of the machine when operating on rough, uneven terrain, and near curbs, holes, and other sudden changes in terrain. Loads may shift, causing the machine to become unstable.
- Before you start the machine, ensure that the transmission is in neutral, the parking brake is engaged, and you are in the operating position.
- You and your passengers should remain seated whenever the machine is moving. Keep your hands on the steering wheel; your passengers should use the handholds provided. Keep arms and legs within the machine body at all times.
- Operate the machine only in good visibility. Watch for holes, ruts, bumps, rocks, or other hidden objects. Uneven terrain could overturn the machine. Tall grass can hide obstacles. Use care

when approaching blind corners, shrubs, trees, or other objects that may obscure your vision.

- Do not drive the machine near drop-offs, ditches, or embankments. The machine could suddenly roll over if a wheel goes over the edge or if the edge gives way.
- Always watch out for and avoid low overhangs such as tree limbs, door jambs, overhead walkways, etc.
- Look behind and down before reversing the machine to be sure of a clear path.
- When using the machine on public roads, follow all traffic regulations and use any additional accessories that may be required by law, such as lights, turn signals, slow-moving vehicle (SMV) signs, and others as required.
- If the machine ever vibrates abnormally, stop and shut off the machine immediately, wait for all movement to stop, and inspect for damage. Repair all damage to the machine before resuming operation.
- It can take longer to stop the machine on wet surfaces than on dry surfaces. To dry out wet brakes, drive slowly on level ground while putting light pressure on the brake pedal.
- Operating the machine at high speed and then quickly stopping may cause the rear wheels to lock up, which impairs your control of the machine.
- Do not touch the motor while the motor is running, or soon after you turn off the motor, because these areas may be hot enough to cause burns.
- Do not leave a running machine unattended.
- Before you leave the operating position, do the following:
 - Park the machine on a level surface.
 - Move the direction selector to the NEUTRAL position.
 - Engage the parking brake.
 - Shut off the machine and remove the key.
 - Wait for all movement to stop.
- Do not operate the machine when there is the risk of lightning.
- Use accessories and attachments approved by The Toro® Company only.

Multi-Passenger Safety

- Do not exceed the gross vehicle weight (GVW) of the machine. You must account for yourself, your passengers, and the load in the cargo bed contributing to the overall GVW of the machine.
- Passengers should sit in the designated seating positions only. Do not allow passengers to sit in the cargo bed.

- You and your passengers should remain seated whenever the machine is in motion.
- The additional machine length results in a larger turn radius, so allow more space to maneuver the machine.

Slope Safety

Note: A 2-post Rollover Protection System (ROPS) is available for this machine as an accessory. Use a ROPS if you will work next to drop-offs, near water, in rough terrain, or on a slope, which could result in a rollover. Contact an authorized Toro distributor for more information.

Slopes are a major factor related to loss-of-control and tip-over accidents, which can result in severe injury or death.

- Survey the site to determine which slopes are safe for operating the machine and establish your own procedures and rules for operating on those slopes. Always use common sense and good judgment when performing this survey.
- If you feel uneasy operating the machine on a slope, do not do it.
- Keep all movement on slopes slow and gradual. Do not suddenly change the speed or direction of the machine.
- Avoid operating the machine on wet terrain. Tires may lose traction. A rollover can occur before the tires lose traction.
- Travel straight up and down a slope.
- If you begin to lose momentum while climbing a slope, gradually engage the brakes and slowly reverse the machine straight down the slope.
- Turning while going up or down a slope can be dangerous. If you must turn on a slope, do it slowly and cautiously.
- Heavy loads affect stability on a slope. Carry a reduced load and reduce your ground speed when operating on a slope or if the load has a high center of gravity. Secure the load to the cargo bed of the machine to prevent the load from shifting. Take extra care when hauling loads that shift easily (e.g., liquids, rock, sand, etc.).
- Avoid starting, stopping, or turning the machine on a slope, especially with a load. Stopping while going down a slope takes longer than stopping on level ground. If you must stop the machine, avoid sudden speed changes, which can cause the machine to tip or roll over. Do not engage the brakes suddenly when rolling rearward, as this may cause the machine to overturn.

Loading and Dumping Safety

- Do not exceed the gross vehicle weight (GVW) of the machine when operating it with a load in the cargo bed and/or towing a trailer; refer to [Specifications \(page 15\)](#).
- Distribute the load in the cargo bed evenly to improve the stability and control of the machine.
- Before dumping, ensure that there is no one behind the machine.
- Do not dump a loaded cargo bed while the machine is sideways on a slope. The change in weight distribution may cause the machine to overturn.

Operating the Cargo Bed

Raising the Cargo Bed to the Dump Position

⚠ WARNING

A raised bed could fall and injure persons that are working beneath it.

- Always use the prop rod to hold the bed up before working under the bed.
- Remove any load material from the bed before raising it.

⚠ WARNING

Driving the machine with the cargo bed raised could cause the machine to tip or roll easier. You could damage the structure of the cargo bed if you operate the machine with the bed raised.

- Operate the machine when the cargo bed is down.
- After emptying the cargo bed, lower it.

⚠ CAUTION

If a load is concentrated near the back of the cargo bed when you release the latches, the bed may unexpectedly tip open, injuring you or bystanders.

- Center loads in the cargo bed, if possible.
- Hold the cargo bed down and ensure that no one is leaning over the bed or standing behind it when releasing the latches.
- Remove all cargo from the bed before lifting the bed up to service the machine.

1. Pull the lever on left, inside of the cargo bed toward you and lift the cargo bed up ([Figure 20](#)).

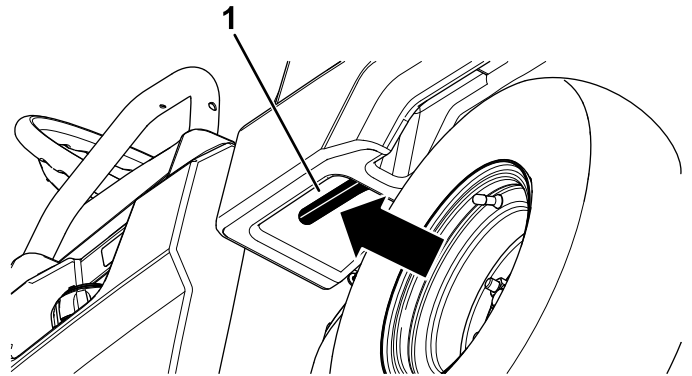

G034019
g034019

Figure 20

1. Cargo-bed lever

2. Pull the prop rod into the dump position detent slot to secure the bed for dumping ([Figure 21](#)).

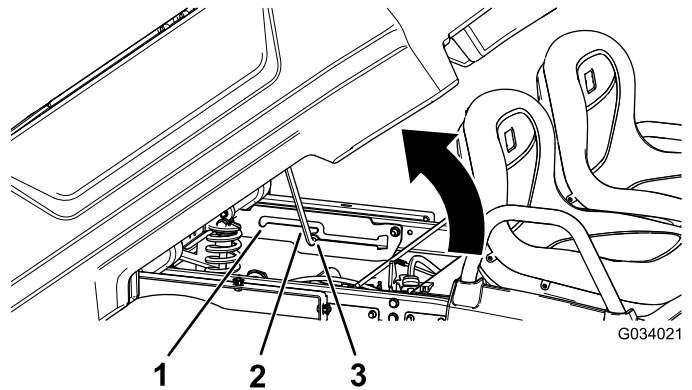

G034021

g034021

Figure 21

1. Service position detent
2. Prop rod
3. Dump position detent slot

Raising the Cargo Bed to the Service Position

1. Pull the lever on left, inside of the cargo bed toward you and lift the cargo bed up (Figure 20).
2. Pull prop rod into the service position detent slot to secure the bed for maintenance (Figure 21).

Lowering the Cargo Bed

⚠ WARNING

The weight of the bed may be heavy. Hands or other body parts could be crushed.

Keep your hands and other body parts away when lowering the bed.

1. Raise the cargo bed slightly by lifting up on the latch lever (Figure 20).
2. Pull the prop rod out of the detent slot (Figure 21).
3. Lower the bed until it latches securely.

Opening the Tailgate

1. Ensure that the cargo bed is down and latched.
2. Using both hands, raise the tailgate using the ridge near the top of the tailgate (Figure 22).
3. Lower the tailgate until it is flush with the bottom of the cargo bed (Figure 22).

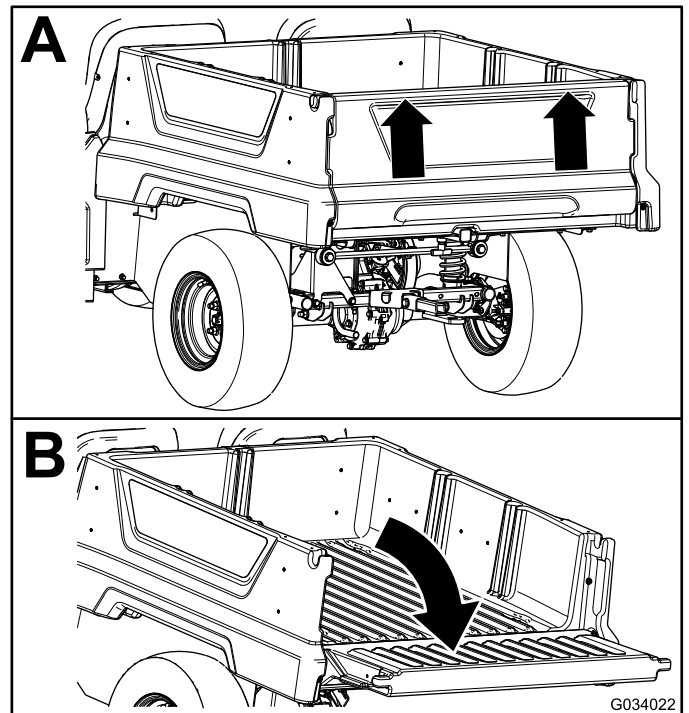

Figure 22

G034022
g034022

Closing the Tailgate

If you unloaded loose material such as sand, landscaping rock, or wood chips from the cargo bed of the machine, some of the material that you unloaded may have lodged in the hinge area of the tailgate. Perform the following steps before closing the tailgate.

1. Use your hands to remove as much of the material from the hinge area as possible.
2. Rotate the tailgate to approximately the 45° position ([Figure 23](#)).

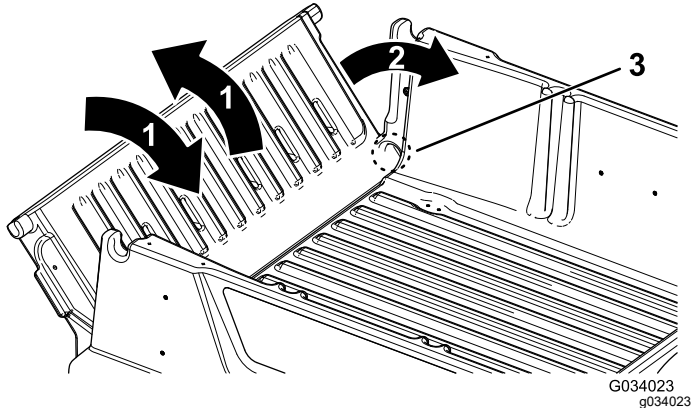

Figure 23

1. Rotate the tailgate back and forth several times.
 2. Rotate the tailgate to approximately the 45° position.
 3. Hinge area
-
3. Use a short, shaking motion to rotate the tailgate back and forth several times ([Figure 23](#)).
Note: This action helps move material away from the hinge area.
 4. Lower the tailgate and check for material remaining in the hinge area.
 5. Repeat steps 1 through 4 until the material is removed from the hinge area.
 6. Rotate the tailgate up and lift the tailgate into the notches in the cargo bed.

Monitoring the Battery-System Charge Level

Refer to the display to determine the battery-system charge level; refer to [Display \(page 12\)](#).

Understanding the Low Battery-Level Advisories

If the battery level becomes too low (i.e., below 5%), a low-battery advisory appears on the display. When you are operating at this battery percentage, drive the machine to a designated battery-charging area and charge the batteries; refer to [Charging the Lithium-Ion Batteries \(page 27\)](#).

Stopping the Machine

Important: When stopping the machine on an incline, use the service brakes to stop the machine and engage the parking brake to hold the machine in place. Using the accelerator to stall the machine on the hill can overheat the motor or drain the batteries.

1. Remove your foot from the accelerator pedal.
2. Slowly press the brake pedal to apply the service brakes until the machine comes to a complete stop.

Note: The stopping distance may vary depending on the machine load and speed.

Loading the Cargo Bed

Use the following guidelines when loading the cargo bed and operating the machine:

- Observe the weight capacity of the machine and limit the weight of the load that you carry in the cargo bed as described in [Specifications \(page 15\)](#) and on the gross vehicle weight tag of the machine.
- **Note:** The load rating is specified for machine operation on a level surface only.
- Reduce the weight of the load that you carry in the cargo bed when operating the machine on hills and rough terrain.
- Reduce the weight of the load that you carry when the materials are tall (and have a high center of gravity), such as a stack of bricks, landscaping timbers, or fertilizer bags. Distribute the load as low as possible to ensure that the load does not reduce your ability to see behind the machine when operating it.
- Keep loads centered by loading the cargo bed as follows:

- Evenly position the weight in the cargo bed from side to side.

Important: Tipping over is more likely to occur if the cargo bed is loaded to 1 side.

- Evenly position the weight in the cargo bed from front to back.

Important: Loss of steering control or the machine may tip over if you position the load behind the rear axle and the traction on the front tires is reduced.

- Use extra caution when transporting oversized loads in the cargo bed, particularly when you cannot center the weight of the oversize load to the cargo bed.
- Whenever possible, secure the load by binding it to the cargo bed so that it does not shift.
- When transporting liquids, use caution when driving the machine uphill or downhill, when suddenly changing speed or stopping, or when driving over rough surfaces.

The capacity of the cargo bed is 0.28 m³ (10 ft³). The amount (volume) of material that you can place in the bed without exceeding the load ratings of the machine can vary greatly depending on the density of the material.

Refer to the following table for load volume limits with various materials:

Material	Density	Maximum Cargo Bed Capacity (on level ground)
Gravel, dry	1522 kg/m ³ (95 lb/ft ³)	Full
Gravel, wet	1922 kg/m ³ (120 lb/ft ³)	3/4 Full
Sand, dry	1442 kg/m ³ (90 lb/ft ³)	Full
Sand, wet	1922 kg/m ³ (120 lb/ft ³)	3/4 Full
Wood	721 kg/m ³ (45 lb/ft ³)	Full
Bark	<721 kg/m ³ (<45 lb/ft ³)	Full
Earth, packed	1602 kg/m ³ (100 lb/ft ³)	3/4 Full (approximately)

After Operation

After Operation Safety

General Safety

- Before you leave the operating position, do the following:
 - Park the machine on a level surface.
 - Move the direction selector to the NEUTRAL position.
 - Engage the parking brake.
 - Shut off the machine and remove the key.
 - Wait for all movement to stop.
- Allow the machine to cool before adjusting, servicing, cleaning, or storing it.
- Do not store the machine where there is an open flame, spark, or pilot light, such as on a water heater or other appliance.
- Keep all parts of the machine in good working condition and all hardware tightened.
- Maintain and clean the seat belt(s) as necessary.
- Replace all worn, damaged, or missing decals.

Battery and Charger Safety

General

- Use only the supplied power cord for battery charging.
- Confirm the voltage that is available in your country before using the charger.
- For connection to a supply not in the US, use an attachment plug adapter of the proper configuration for the power outlet, if needed.
- Do not charge the machine in rain or wet conditions.
- A risk of fire, electric shock, or injury may result from using an accessory not recommended or sold by Toro.
- To reduce risk of a battery explosion, follow these instructions and the instructions for any equipment that you intend to use near the charger.
- Do not open batteries.
- In the event that a battery leaks, avoid contact with the liquid. If you accidentally come into contact with the liquid, flush with water and seek medical help. Liquid ejected from the battery may cause irritation or burns.
- Refer to an authorized Toro distributor to service or replace a battery.

Training

- Never allow children or untrained people to operate or charge the machine. Local regulations may restrict the age of the operator. The owner is responsible for training all operators and mechanics.
- Read, understand, and follow all instructions on charging the machine.

Preparation

- Keep bystanders and children away while charging.
- Wear appropriate clothing while charging, including eye protection; long pants; and substantial, slip-resistant footwear.
- Shut off the machine and wait 5 seconds until the machine has completely powered down before charging. Failure to do this may cause arcing.
- Ensure that the area is well ventilated while charging.
- Read and follow all precautions for charging.
- The charger is for use only on nominal 100 to 240 VAC circuits, and is equipped with a grounding plug for 120 VAC operation. For use with 240 V circuits, contact your authorized Toro distributor for the correct power cord.
- Use only a power cord approved by Toro.

Operation

- Do not abuse the power supply cord or yank on it to disconnect the charger from the receptacle. Keep the cord from heat, oil, and sharp edges.
- Connect the charger directly to a grounding receptacle. Do not charge on an ungrounded outlet, even with an adaptor.
- Do not alter the provided power cord or plug.
- Avoid dropping a metal tool near or onto a battery; it might cause a spark or short-circuit an electrical part that could lead to an explosion.
- Remove metal items such as rings, bracelets, necklaces, and watches when working with a lithium-ion battery. A lithium-ion battery can produce enough current to cause a severe burn.
- Use an appropriate extension cord.
- If the power supply cord is damaged while it is plugged in, disconnect the cord from the wall receptacle and contact an authorized Toro distributor for a replacement.
- Unplug the charger from the electrical outlet when not in use, before moving it to another location, or prior to servicing it.

Maintenance and Storage

- Store the machine indoors in a dry, secure place that is out of the reach of unauthorized users.
- Unplug the power cord from the outlet before starting any maintenance or cleaning to reduce risk of electric shock.
- Maintain or replace safety and instruction labels as needed.
- Do not charge with a damaged cord or plug. Replace a damaged cord or plug immediately.
- If the charger or power cord is damaged, do not use it; take it to an authorized Toro distributor.

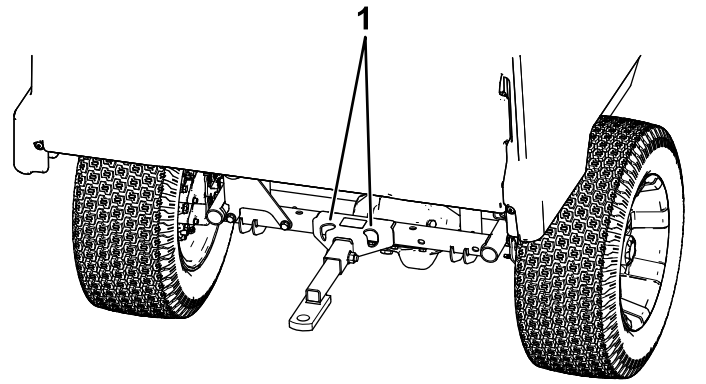

Figure 25

1. Rear tie-down points

Hauling the Machine

- Use care when loading or unloading the machine into a trailer or a truck.
- Use full-width ramps for loading the machine into a trailer or a truck.
- Tie the machine down securely.

Refer to [Figure 24](#) and [Figure 25](#) for the tie-down locations on the machine.

Note: Load the machine on the trailer with the front of the machine facing forward. If that is not possible, secure the machine hood to the frame with a strap, or remove the hood and transport and secure it separately or the hood may blow off during transport.

⚠ CAUTION

Loose seats may fall off the machine and trailer when transporting the machine, and the seats may land on another machine or obstruct the roadway.

Remove the seats or ensure that the seats are secured by the pivot pins.

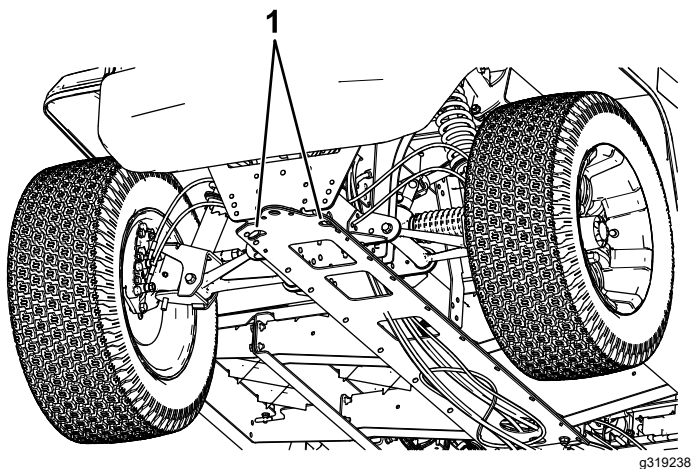

Figure 24

1. Towing tongue and tie-down point (front of the machine)

Towing the Machine

In case of an emergency, you can tow the machine for a short distance; however, this should not be a standard operating procedure.

⚠ WARNING

Towing at excessive speeds could cause a loss of steering control, resulting in personal injury.

Never tow the machine at faster than 8 km/h (5 mph).

Towing the machine is a 2-person job. If you must move the machine a considerable distance, transport it on a truck or trailer; refer to [Towing a Trailer \(page 25\)](#).

1. Shut off the machine and remove the key.

***Important:* If you tow the machine with the key in the ON position, the electrical system may be damaged.**

2. Affix a tow line to the tongue at the front of the machine's frame ([Figure 24](#)).
3. Disengage the parking brake.

Towing a Trailer

The machine is capable of pulling trailers. Tow hitches are available for the machine, contact your authorized Toro distributor for details.

When hauling cargo or towing a trailer, do not overload your machine or trailer. Overloading either the machine or the trailer can cause poor performance or damage to the brakes, axle, motor, transaxle, steering, suspension, body structure, or tires.

Always load a trailer with 60% of the cargo weight in the front of the trailer. This places approximately 10% of the gross trailer weight (GTW) on the tow hitch of the machine.

To provide adequate braking and traction, always load the cargo bed when using a trailer. Do not exceed the GTW or GVW limits.

Avoid parking a machine with a trailer on a hill. If you must park on a hill, engage the parking brake and block the tires of the trailer.

Maintaining the Lithium-Ion Batteries

⚠ WARNING

The batteries contain high voltage, which could burn or electrocute you.

- Do not attempt to open the batteries.
- Use extreme care when handling a battery with a cracked case.
- Use only the charger designed for the batteries.

To achieve maximum life and use from your batteries, follow these guidelines:

- Do not open the battery. There are no user serviceable parts inside. If you open the pack, you will void your warranty. The batteries are protected by tamper-alerting devices.
- Store/park the machine in a clean, dry garage or storage area, **away from direct sunlight, heat sources, rain, and wet conditions**. Refer to the **table below** for temperature requirements for storage.

Important: Temperatures outside of this range will damage your batteries.

High temperatures during storage, especially at a high state of charge, reduces the life of the batteries.

Temperature Requirements for Storage

Storage Conditions	Temperature Requirement
Normal storage conditions	-20° to 45°C (-12° to 113°F)
Extreme heat—1 month or less	45° to 60°C (113° to 140°F)
Extreme cold—3 months or less	-30° to -20°C (-22° to -12°F)

- When storing the machine for more than 10 days, ensure that the machine is in a cool and dry location, out of sunlight, rain, and wet conditions, and at least 50% charged.
- To check the charging status, turn the key switch to the ON position. When you are done viewing the charging status, turn the key switch to the OFF position to optimize charging efficiency.

This machine is equipped with an automatic power shutoff to preserve and maintain the battery performance and capacity.

If you leave the key switch in the ON position for an extended period of time, an automatic power shutoff will occur after the following:

- When charging, automatic shutoff occurs after 5 minutes of charge current below 3 A (100% charged).
- Automatic shutoff occurs after 30 minutes of normal inactivity. The automatic shutoff time can be changed by an authorized Toro distributor.

Transporting the Lithium-Ion Batteries

The US Department of Transportation and international transportation authorities require that lithium-ion batteries be transported using special packaging and only be transported by carriers certified to haul them. In the US, you are allowed to transport a battery when it is installed on the machine as battery powered equipment, with some regulatory requirements. Contact the US Department of Transportation or the appropriate government body in your country for detailed regulations on transportation of your batteries or the machine with the batteries equipped.

For detailed information on shipping a battery, contact your authorized Toro distributor.

Understanding the Lithium-Ion Battery Charger

Connecting to a Power Source

To reduce the risk of electric shock, this charger has a 3-prong grounded plug (type B). If the plug does not fit into the wall receptacle, other grounded plug types are available; contact an authorized Toro distributor.

Do not change the charger or the power-supply-cord plug in any way.

See [Figure 26](#) for power source requirements.

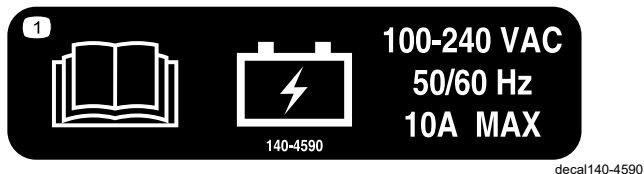

Figure 26

⚠ DANGER

Contact with water while charging the machine could cause electric shock, causing injury or death.

- Do not handle the plug or the charger with wet hands or while standing in water.
- Do not charge the batteries in the rain or in wet conditions.

Important: Check the power supply cord periodically for holes or cracks in the insulation. Do not use a damaged cord. Do not run the cord through standing water or wet grass.

1. Plug the cord into the machine charger outlet.

⚠ WARNING

A damaged charger cord can cause an electrical shock or a fire.

Thoroughly inspect the power supply cord before using the charger. If the cord is damaged, do not operate the charger until you obtain a replacement.

2. Insert the wall plug end of the power-supply cord into a grounded electrical outlet.

Charging the Lithium-Ion Batteries

Important: Charge the batteries only in temperatures that are within the recommended range; refer to the following table for the recommended range:

Note: The charger will not function in temperatures exceeding the minimum or maximum temperatures shown in the following table.

Recommended Temperature Range for Charging

Charging range	5° to 45°C (41° to 113°F)
Low-temperature charging range (Reduced Current)	-10° to 5°C (14° to 41°F)
High-temperature charging range (Reduced Current)	45° to 60°C (113° to 140°F)

Monitoring the Charging Process and Troubleshooting

To view the current charging status, turn the key switch to the ON position. When you are done viewing the charging status, turn the key switch to the OFF position to optimize the charging process.

Note: The display shows messages during the course of charging. Most are routine.

If there is a fault, the error-indicator light will flash amber or a solid, light red. An error message will appear on the display 1 digit at a time, starting with the letter E or F (e.g., E-0-1-1).

To correct an error, refer to [Troubleshooting \(page 49\)](#). If none of these solutions correct the issue, contact an authorized Toro distributor.

Completing the Charging Process

When charging is complete, the battery-charging indicator light shows solid green and the charging-output indicator light disappears.

1. Remove the plugged in cord from the machine charger outlet.
2. Place the cord in a storage position that avoids damage.
3. Turn on the machine.
4. Verify the charge level; refer to [Display \(page 12\)](#).

Maintenance

Note: The procedures in this section show a machine with a plastic cargo bed and bucket seat; for additional procedures for other attachments, refer to the Maintenance section (if applicable) in the Installation Instructions. Visit www.Toro.com for your instructions or scan the QR code (if applicable) on your attachment.

Maintenance Safety

- Do not allow untrained personnel to service the machine.
- Before you leave the operating position, do the following:
 - Park the machine on a level surface.
 - Move the direction selector to the NEUTRAL position.
 - Engage the parking brake.
 - Shut off the machine and remove the key.
 - Wait for all movement to stop.
- Allow the machine to cool before adjusting, servicing, cleaning, or storing it.
- Support the machine with jack stands whenever you work under the machine.
- Do not work under a raised bed without the proper bed safety support in place.
- Do not charge the batteries while servicing the machine.
- To ensure that the entire machine is in good condition, keep all hardware properly tightened.
- To reduce the potential fire hazard, keep the machine area free of excessive grease, grass, leaves, and accumulation of dirt.
- If possible, do not perform maintenance while the machine is running. Keep away from moving parts.
- If you must run the machine to perform a maintenance adjustment, keep your hands, feet, clothing, and any parts of the body away from any moving parts. Keep bystanders away from the machine.
- Check the parking brake operation as recommended in the maintenance schedule and adjust and service it as required.
- Keep all parts of the machine in good working condition and all the hardware properly tightened. Replace all worn or damaged decals.
- Never interfere with the intended function of a safety device or reduce the protection provided by a safety device.
- If major repairs are ever necessary or assistance is required, contact an authorized Toro distributor.
- Altering this machine in any manner may affect the operation of the machine, performance, durability, or its use may result in injury or death. Such use could void the product warranty of The Toro® Company.

Recommended Maintenance Schedule(s)

Maintenance Service Interval	Maintenance Procedure
After the first 100 hours	<ul style="list-style-type: none"> • Perform the breaking in a new machine guidelines.
Before each use or daily	<ul style="list-style-type: none"> • Inspect the seat belt(s) for wear, cuts, and other damage. Replace the seat belt(s) if any component does not operate properly. • Check the tire pressure. • Check the brake-fluid level. • Wash the machine.
Every 100 hours	<ul style="list-style-type: none"> • Check the condition of the tires and rims. • Torque the wheel-lug nuts. • Inspect the steering and suspension for loose or damaged components. • Check the front wheel camber and toe-in. • Check the transaxle-fluid level. • Check the transaxle for leaks. • Inspect the brakes.
Every 300 hours	<ul style="list-style-type: none"> • Grease the front wheel bearings.
Every 400 hours	<ul style="list-style-type: none"> • Replace the service and parking-brake pads.

Maintenance Service Interval	Maintenance Procedure
Every 800 hours	• Change the transaxle fluid.
Every 1,000 hours	• Change the brake fluid.

Note: Download a free copy of the electrical schematic by visiting www.Toro.com and searching for your machine from the Manuals link on the home page.

⚠ WARNING

Failure to properly maintain the machine could result in premature failure of machine systems, causing possible harm to you or bystanders.

Keep the machine well maintained and in good working order as indicated in these instructions.

Daily Maintenance Checklist

Duplicate this page for routine use.

Maintenance Check Item	For the week of:						
	Monday	Tuesday	Wednesday	Thursday	Friday	Saturday	Sunday
Check the brake and parking brake operation.							
Check the gear shift/neutral operation.							
Check the brake-fluid level.							
Check for unusual operating noises.							
Check the tire pressure.							
Check for fluid leaks.							
Check the instrument operation.							
Check the accelerator operation.							
Touch up any damaged paint.							
Wash the machine.							

Maintaining the Machine under Special Operating Conditions

Important: If the machine is subjected to any of the conditions listed below, perform maintenance twice as frequently:

- Desert operation
- Cold climate operation—below 10°C (50°F)
- Trailer towing
- Frequent operation in dusty conditions
- Construction work
- After extended operation in mud, sand, water, or similar dirty conditions, do the following:
 - Have your brakes inspected and cleaned as soon as possible. This prevents any abrasive material from causing excessive wear.
 - Wash the machine using water alone or with a mild detergent.

Important: Do not use brackish or reclaimed water to clean the machine.

Pre-Maintenance Procedures

⚠ WARNING

Raise the cargo bed before performing maintenance. A raised cargo bed can fall and injure persons that are underneath it.

- Always use the prop rod to hold the cargo bed up before working underneath it.
- Remove any load material from the cargo bed before working underneath it.

Preparing the Machine for Maintenance

1. Park the machine on a level surface.
2. Move the direction selector to the NEUTRAL position.
3. Engage the parking brake.
4. Shut off the machine and remove the key.
5. Empty and raise the cargo bed.

Lifting the Machine

⚠ DANGER

The machine may be unstable when using a jack. The machine could slip off the jack, injuring anyone beneath it.

- Do not start the machine while the machine is on a jack.
- Always remove the key from the key switch before getting off the machine.
- Block the tires when the machine is supported by lifting equipment.
- Use jack stands to support the machine once you have lifted it.

Important: Whenever you run the machine for routine maintenance and/or diagnostics, ensure that the rear wheels of the machine are 25 mm (1 inch) off the ground, with the rear axle supported on jack stands.

- The lifting point at the front of the machine is located at the front of the frame, behind the towing tongue (Figure 27).

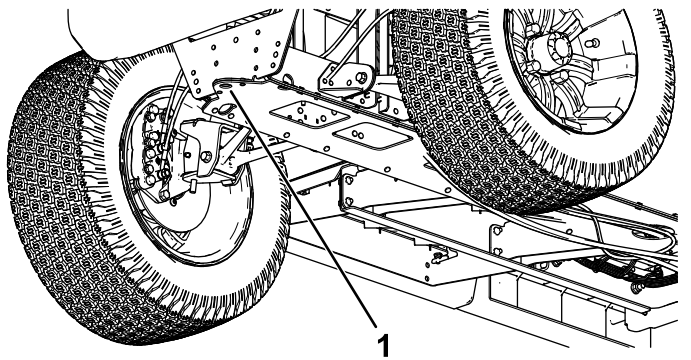

Figure 27

1. Front lifting point

- The lifting point at the rear of the machine is located under the axle tubes (Figure 28).

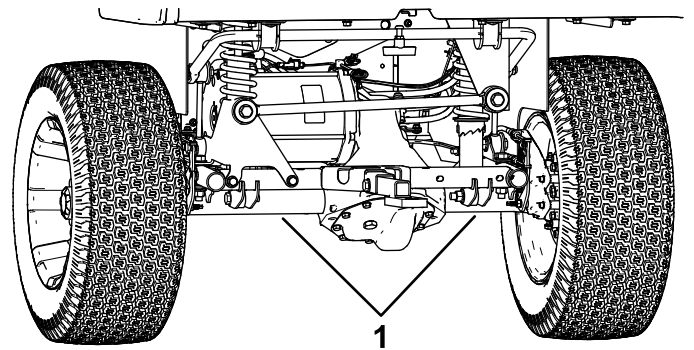

Figure 28

1. Rear lifting points

Accessing the Hood

Raising the Hood

1. Lift up the handle of the rubber latches on each side of the hood (Figure 29).

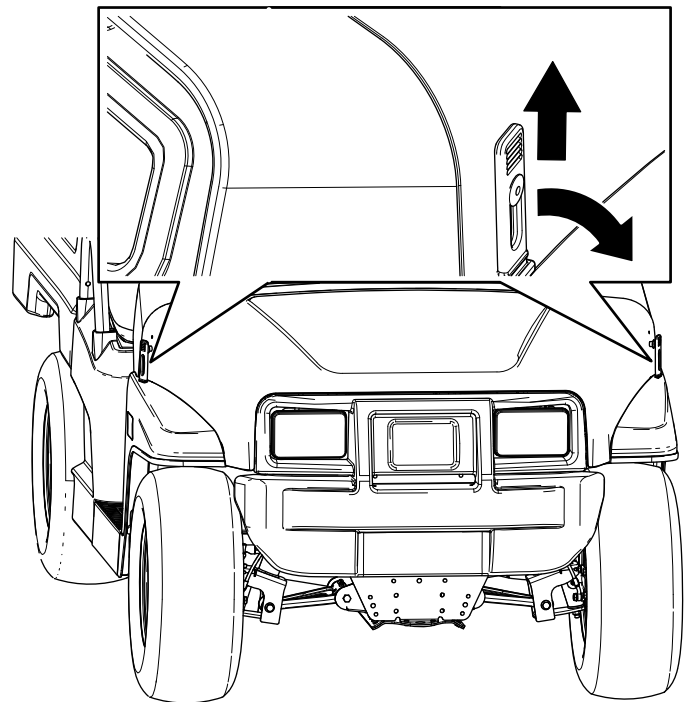

Figure 29

2. Raise the hood.

Closing the Hood

1. Gently lower the hood.
2. Secure the hood by aligning the rubber latches onto the latch anchors on each side of the hood (Figure 29).

Raising and Lowering the Seat Assembly

To raise the seat assembly, push the seat assembly forward until it rests on the steering wheel (Figure 30).

To lower the seat assembly, push the seat assembly rearward until it seats back into the original position (Figure 30).

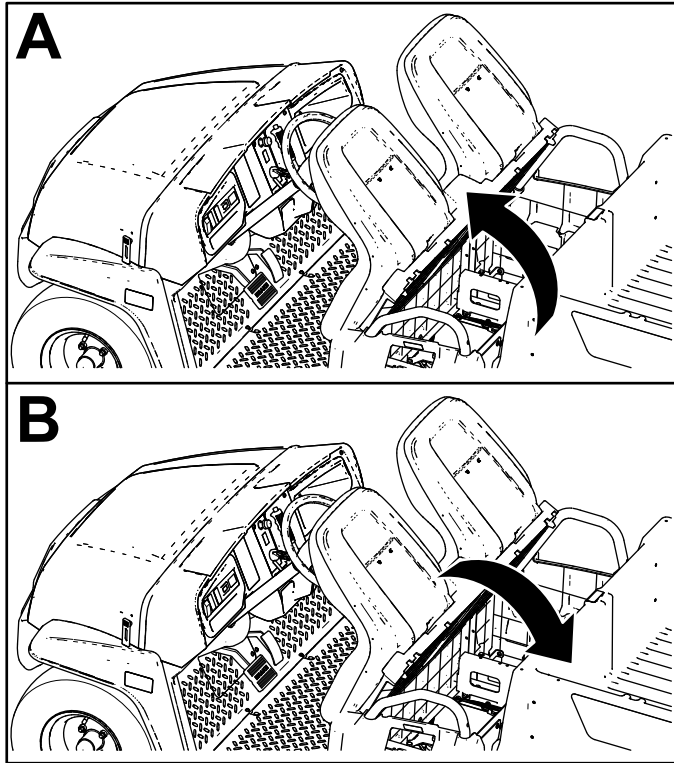

Figure 30

g190066

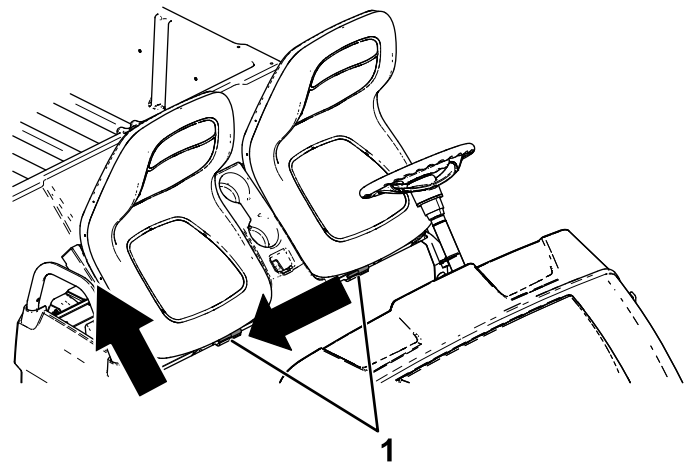

Figure 31

g190187

1. Pins

Installing a Bucket Seat

Slide the seat assembly onto the pins and lower the seat assembly (Figure 32).

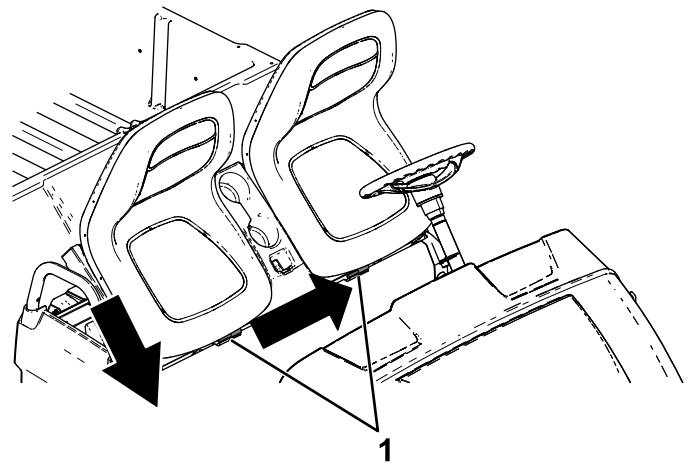

Figure 32

g190186

1. Pins

Removing a Bucket Seat

1. Push the seat assembly forward to the raised position (Figure 30).
2. Slide the seat assembly to the side out of the pins, and lift the seat assembly upward (Figure 31).

Removing a Bench Cushion

1. Push the bench cushion forward to the raised position.
2. Slide the cushion to the side, out of the pins, and lift the cushion upward (Figure 33).

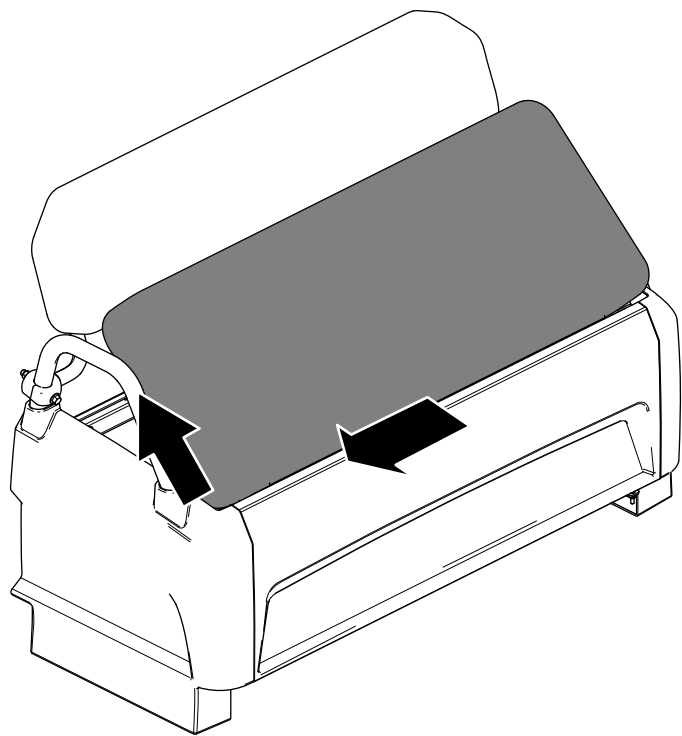

Figure 33

g237191

Installing a Bench Cushion

Slide the bench cushion onto the pins and lower the cushion (Figure 34).

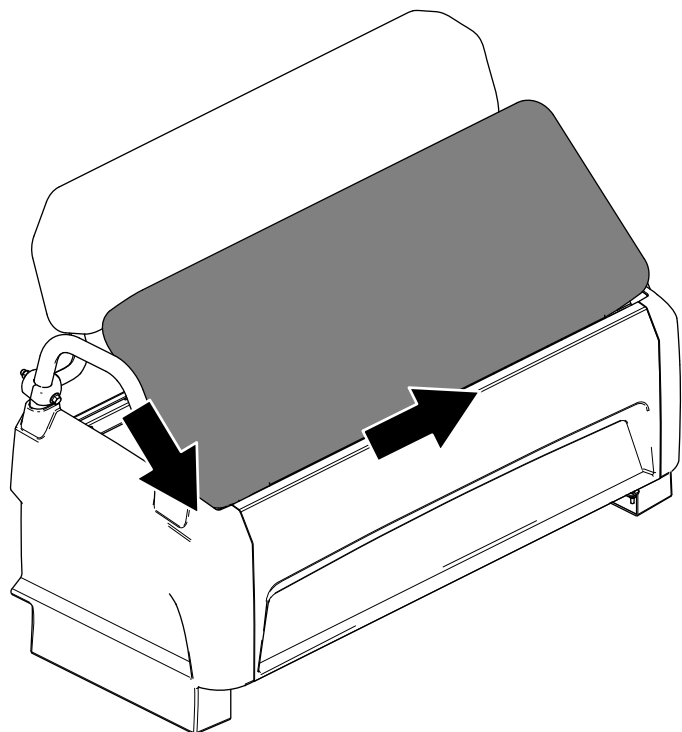

Figure 34

g237190

Lubrication

Greasing the Front Wheel Bearings

Service Interval: Every 300 hours

Grease specification: Mobilgrease XHP™-222

Removing the Hub and Rotor

1. Lift the front of the machine and support it with jack stands.
2. Remove the 4 lug nuts that secure the wheel to the hub (Figure 35).

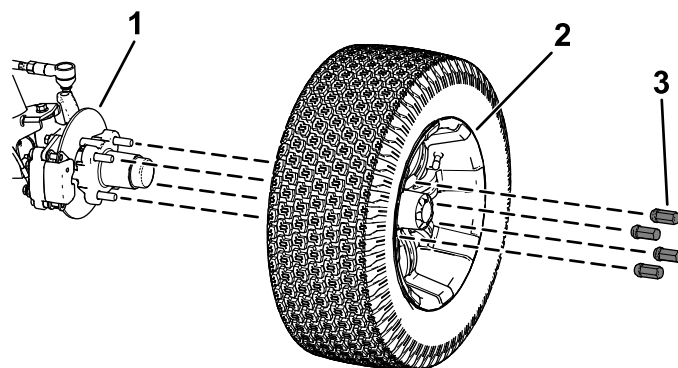

Figure 35

g321364

1. Hub
2. Wheel
3. Lug nut

3. Remove the flange-head bolts (3/8 x 3/4 inch) that secure the bracket for the brake assembly to the spindle and separate the brake from the spindle (Figure 36).

Note: Support the brake assembly before proceeding to the next step.

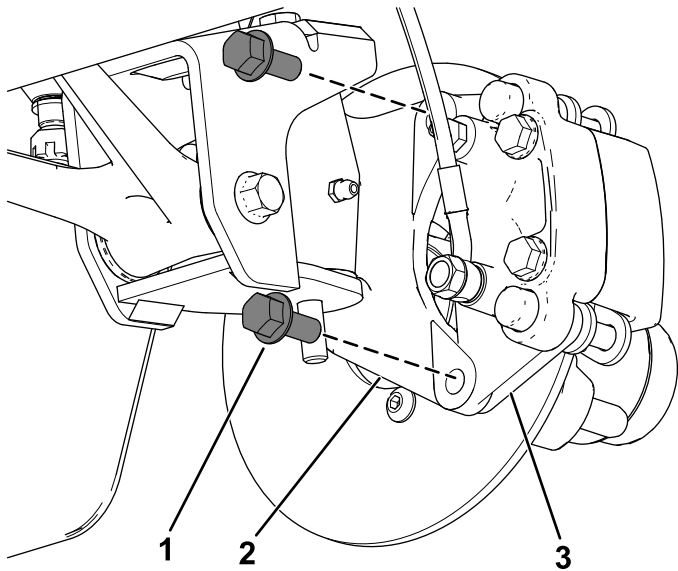

Figure 36

g321363

- | | |
|---------------------------------------|-------------------------------------|
| 1. Flange-head bolts (3/8 x 3/4 inch) | 3. Caliper bracket (brake assembly) |
| 2. Spindle | |

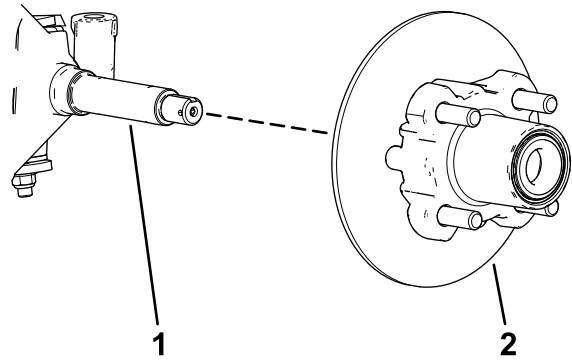

Figure 38

g192347

- | | |
|------------|---------------------------|
| 1. Spindle | 2. Hub and rotor assembly |
|------------|---------------------------|

-
4. Remove the dust cap from the hub ([Figure 37](#)).

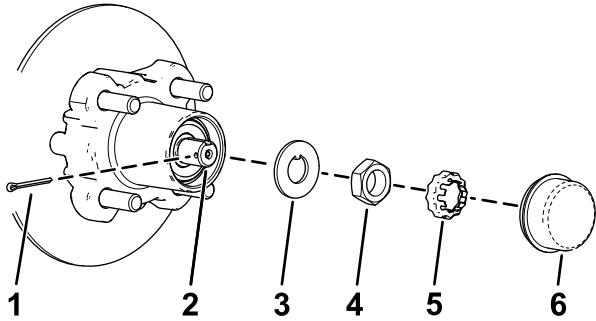

Figure 37

g192346

- | | |
|---------------|-----------------|
| 1. Cotter pin | 4. Spindle nut |
| 2. Spindle | 5. Nut retainer |
| 3. Tab washer | 6. Dust cap |

-
5. Remove the cotter pin and nut retainer from the spindle and spindle nut ([Figure 37](#)).
6. Remove the spindle nut from the spindle, and separate the hub and rotor assembly from the spindle ([Figure 37](#) and [Figure 38](#)).

Greasing the Wheel Bearings

1. Remove the outboard bearing and bearing race from the hub (Figure 39).

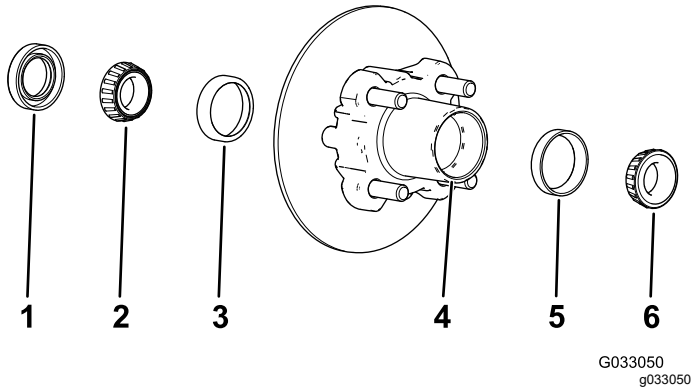

Figure 39

- | | |
|-------------------------|--------------------------|
| 1. Seal | 4. Bearing cavity (hub) |
| 2. Inboard bearing | 5. Outboard-bearing race |
| 3. Inboard-bearing race | 6. Outboard bearing |

2. Remove the seal, inboard bearing from the hub (Figure 39).
3. Wipe clean the seal and check for wear and damage.

Note: Do not use cleaning solvent to clean the seal. Replace the seal if it is worn or damaged.
4. Clean the bearings and races, and check these parts for wear and damage.

Note: Replace all worn or damaged parts. Ensure that the bearings and races are clean and dry.
5. Clean the cavity of the hub of all grease, dirt, and debris (Figure 39).
6. Pack the bearings with the specified grease.
7. Fill the cavity of hub 50 to 80% full of the specified grease (Figure 39).
8. Assemble the inboard bearing onto the race at the inboard side of the hub and install the seal (Figure 39).
9. Repeat steps 1 through 8 to the bearings for the other hub.

Installing the Hub and Rotor

1. Apply a light coat of the specified grease to the spindle (Figure 40).

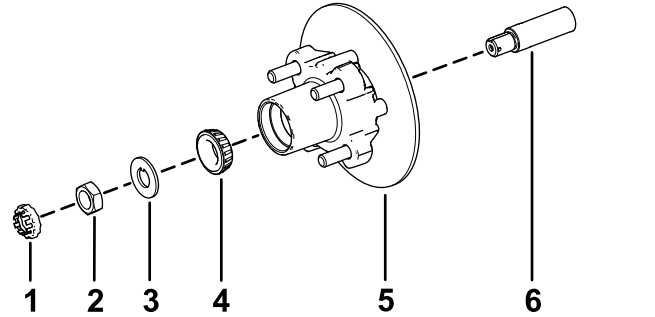
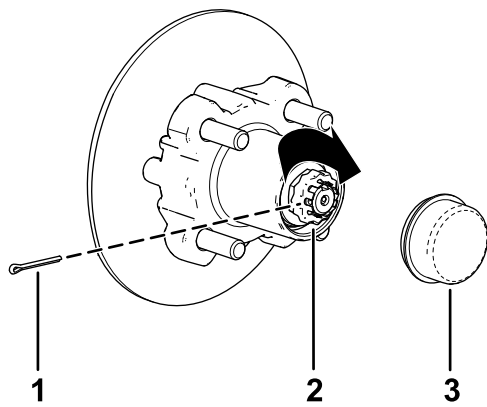

Figure 40

- | | |
|-----------------|--|
| 1. Nut retainer | 4. Outer bearing |
| 2. Spindle nut | 5. Hub, rotor, inner bearing, race, and seal |
| 3. Tab washer | 6. Spindle |

2. Assemble the hub and rotor onto the spindle with the rotor inboard (Figure 40).
3. Assemble the outboard bearing onto the spindle and seat the bearing to the outboard race (Figure 40).
4. Assemble the tab washer onto the spindle (Figure 40).
5. Thread the spindle nut onto the spindle and tighten the nut to 15 N·m (11 ft-lb), while rotating the hub to seat the bearing (Figure 40).
6. Loosen the spindle nut until the hub rotates freely.
7. Torque the spindle nut to 170 to 225 N·cm (15 to 20 in-lb).
8. Install the retainer over the nut and check the alignment of the slot in the retainer and the hole in the spindle for the cotter pin (Figure 41).

Note: If the slot in the retainer and the hole in the spindle are not aligned, tighten the spindle nut to align the slot and hole to a maximum torque of 226 N·cm (20 in-lb) on the nut.



g192345

Figure 41

- | | |
|-----------------|-------------|
| 1. Cotter pin | 3. Dust cap |
| 2. Nut retainer | |

9. Install the cotter pin and bend each leg around the retainer (Figure 41).
10. Install the dust cap onto the hub (Figure 41).
11. Repeat steps 1 through 10 for the hub and rotor at the other side of the machine.

Installing the Brakes and Wheels

1. Clean the 2 flange-head bolts (3/8 x 3/4 inch) and apply a coat of medium-strength thread-locking compound to the threads of the bolts.
2. Align the brake pads to either side of the rotor (Figure 36) and the holes in the caliper bracket with the holes in the brake mount of the spindle frame (Figure 40).
3. Secure the caliper bracket to the spindle frame (Figure 36) using the 2 flange-head bolts (3/8 x 3/4 inch).

Torque the 2 flange-head bolts to 47 to 54 N·m (35 to 40 ft-lb).

4. Align the holes in the wheel to the studs of the hub and assemble the wheel to the hub with the valve stem outward (Figure 35).

Note: Ensure that the mounting surface of the wheel is flush with the hub.

5. Secure the wheel to the hub using the lug nuts (Figure 35).

Torque the lug nuts to 108 to 122 N·m (80 to 90 ft-lb).

6. Repeat steps 1 through 5 for the brake and wheel on the other side of the machine.

Electrical System Maintenance

Electrical System Safety

- Unplug the power cord before connecting or disconnecting the battery.
- Wear protective clothing and use insulated tools. Disconnect the battery before repairing the machine. Disconnect the negative terminal first and the positive last. Connect the positive terminal first and the negative last.

Disconnecting the Batteries

1. Remove the negative (-) battery terminal boot from the front battery pack (Figure 42).

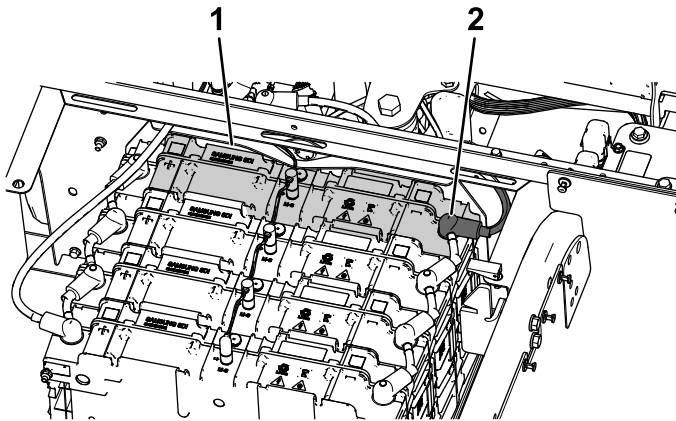

Figure 42

g322757

1. Front battery pack
2. Negative (-) battery terminal boot

2. Remove the flange nut and negative (-) battery cable from the battery post (Figure 43).

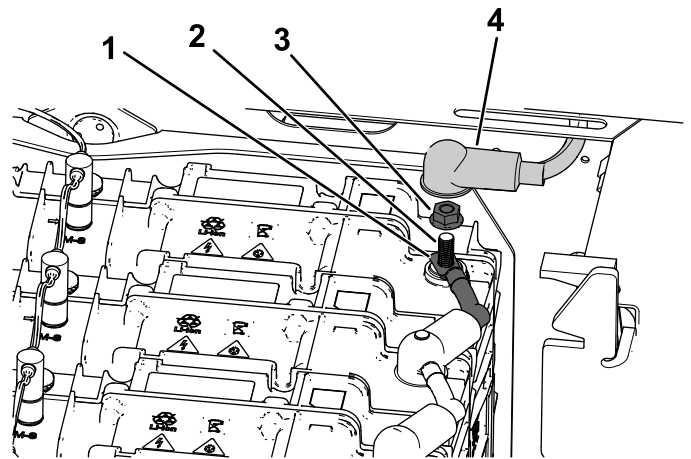

Figure 43

g322758

1. Negative (-) battery cable
2. Battery post
3. Flange nut
4. Negative (-) battery terminal boot

Connecting the Batteries

1. Secure the negative (-) battery cable to the battery post using the flange nut (Figure 43).
2. Install the negative (-) battery terminal boot over the battery post (Figure 43).

Replacing a Fuse

There are 6 fuses in the electrical system; the other slots are open for options.

The display fuse (2 A) is located at the front of machine under the hood (Figure 44).

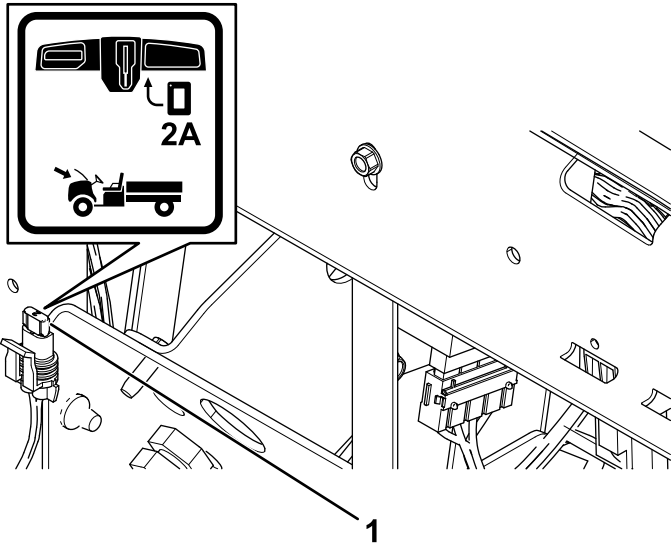

Figure 44

g320397

1. Display fuse (2 A)

The 12 V and 48 V fuses are located under the seat assembly (Figure 45).

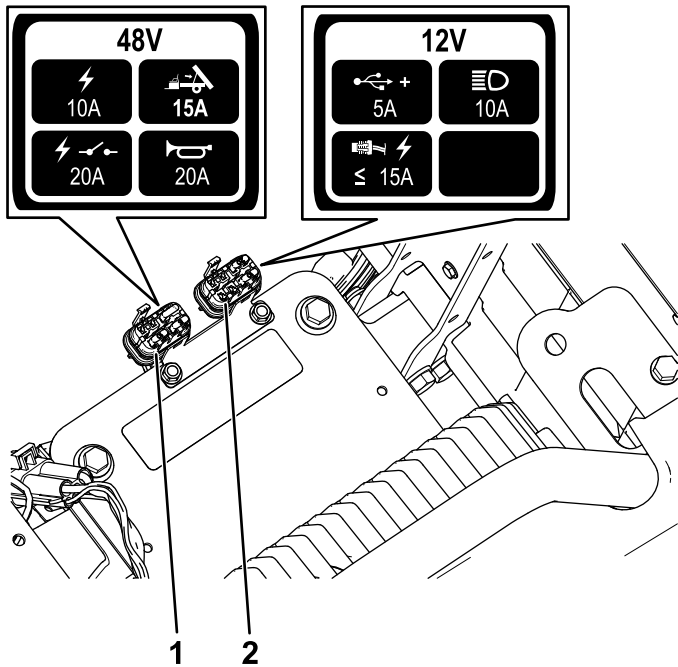

Figure 45

g377987

1. 12 V fuse block
2. 48 V fuse block

48 V Fuses

Main power	10 A
Optional lift kit—open	15 A
Electric relay	20 A
Horn	20 A
Display	2 A

12 V Fuses

USB power point	5 A
Headlights	10 A
Electric power	15 A

Maintaining the Headlights

Replacing the Headlight

1. Disconnect the batteries; refer to [Disconnecting the Batteries](#) (page 37).
2. Open the hood.
3. Disconnect the electrical connector for the harness from the connector of the lamp assembly ([Figure 46](#)).

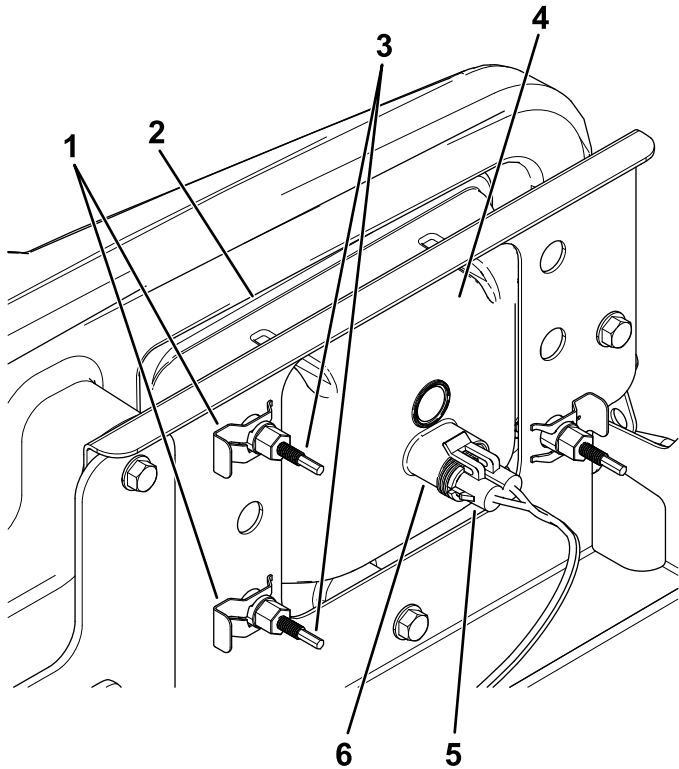

Figure 46

g319306

- | | |
|--------------------------|---------------------------------|
| 1. Speed clip | 4. Headlight |
| 2. Opening in the bumper | 5. Harness electrical connector |
| 3. Adjustment screw | 6. Lamp assembly |

4. Remove the speed clips that secure the headlight to the headlight bracket ([Figure 46](#)).
Note: Retain all parts for installation of the new headlight.
5. Remove the headlight assembly by moving it forward through the opening in the front bumper ([Figure 46](#)).
6. Install the new headlight through the opening in the bumper ([Figure 46](#)).
Note: Ensure the adjustment posts are lined up with the holes in the mounting bracket behind the bumper.
7. Secure the headlight assembly with the speed clips that you removed in step 4.

8. Connect the electrical connector for the harness to the connector of the lamp assembly ([Figure 46](#)).
9. Adjust the headlights to direct the beams to the desired position, refer to [Adjusting the Headlights](#) (page 39).

Adjusting the Headlights

Use the following procedure to adjust the headlight beam position whenever a headlight assembly is replaced or removed.

1. Park the machine on a level surface with the headlights approximately 7.6 m (25 ft) from a wall ([Figure 47](#)).
2. Measure the distance from the floor to the center of the headlight and make a mark on the wall at the same height.
3. Turn the key switch to the ON position, and turn on the headlights.
4. Take note of where the headlight beams aim on the wall.

The brightest part of the headlight beam should be 20 cm (8 inches) below the mark placed on the wall ([Figure 47](#)).

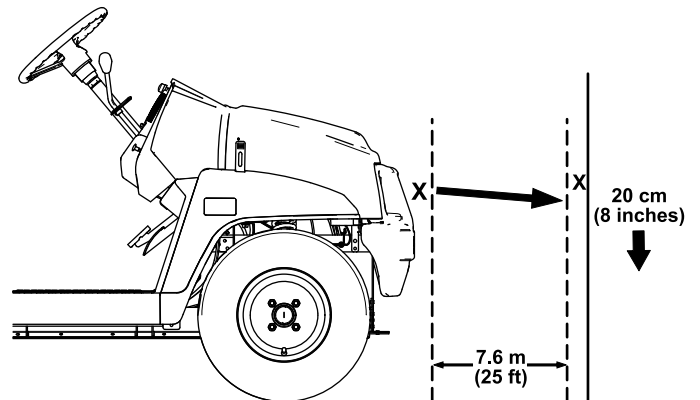

Figure 47

g298100

5. At the back of the headlight assembly, rotate adjustment screws ([Figure 46](#)) to pivot the headlight assembly and align the position of the cast beam.
6. Connect the batteries and close the hood; refer to [Connecting the Batteries](#) (page 37).

Servicing the Batteries

Note: The machine is equipped with 4 lithium-ion batteries.

A lithium-ion battery must be disposed of or recycled in accordance with local and federal regulations. If a battery requires service, contact your authorized Toro distributor for assistance.

The only user serviceable parts on a battery are the labels. If you attempt to open the main compartment of a battery, you will void your warranty. If you are having problems with a battery, contact your authorized Toro distributor for assistance.

Maintaining the Battery Charger

Important: All electrical repairs should be performed by an authorized Toro distributor only.

The operator can perform very little maintenance other than protecting the charger from damage and weather.

Maintaining the Battery-Charger Cords

- Clean the cords with a slightly damp cloth after each use.
- Coil the cords when not in use.
- Periodically examine the cords for damage, and replace them when necessary with Toro-approved parts.

Drive System Maintenance

Maintaining the Tires

Service Interval: Every 100 hours—Check the condition of the tires and rims.

Every 100 hours—Torque the wheel-lug nuts.

1. Inspect the tires and rims for signs of wear and damage.

Note: Operating accidents, such as hitting curbs, can damage a tire or rim and also disrupt wheel alignment, so inspect tire condition after an accident.

2. Torque the wheel lug nuts to 108 to 122 N·m (80 to 90 ft-lb).

Inspecting the Steering and Suspension Components

Service Interval: Every 100 hours—Inspect the steering and suspension for loose or damaged components.

With the steering wheel at the centered position (Figure 48), turn the steering wheel to the left or right. If you turn the steering wheel more than 13 mm (1/2 inch) to the left or right, and the tires do not turn, check the following steering and suspension components to ensure that they are not loose or damaged:

- Steering shaft to the steering-rack assembly joint
- **Important:** Inspect the condition and security of the pinion-shaft seal (Figure 49).
- Steering-rack assembly tie rods

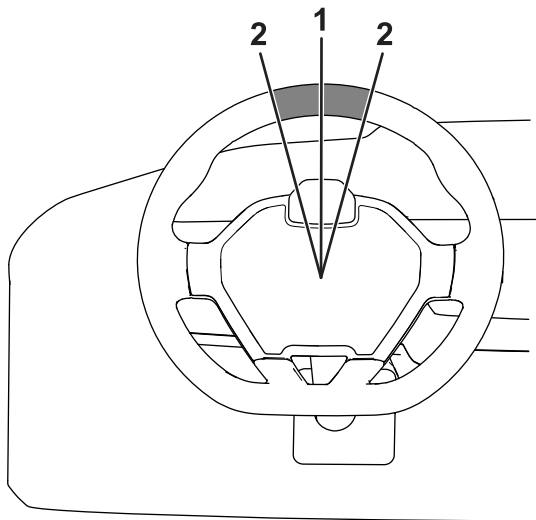

Figure 48

g415333

1. Steering wheel at the centered position
2. 13 mm (1/2 inch) from the center of the steering wheel

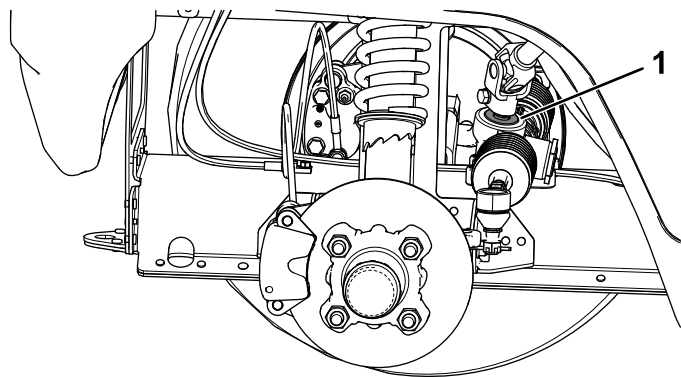

Figure 49

g313576

1. Pinion-shaft seal

Adjusting the Front Wheel Alignment

Service Interval: Every 100 hours/Yearly (whichever comes first)—Check the front wheel camber and toe-in.

Preparing to Adjust Camber or Toe-in

1. Check the tire pressure to ensure that the front tires are inflated to 82 kPa (12 psi).
2. Either add weight to the driver's seat equal to the average operator who will run the machine, or have an operator sit on the seat. The weight or operator must remain on the seat for the duration of the adjustment procedure.
3. On a level surface, roll the machine straight back 2 to 3 m (6 to 10 ft) and then straight forward to the original starting position. This allows the suspension to settle into the operating position.

Adjusting the Camber

Owner provided tools: spanner wrench, Toro Part 132-5069; refer to your authorized Toro distributor.

Important: Make the camber adjustments only if you are using a front attachment or if there is uneven tire wear.

1. Check the camber alignment at each wheel; the alignment should be as close to neutral (zero) as possible.

Note: The tires should be aligned with the tread evenly on the ground to reduce uneven wear.

2. If the wheel camber is out of alignment, use the spanner wrench to rotate the collar on the shock absorber to align the wheel (Figure 50).

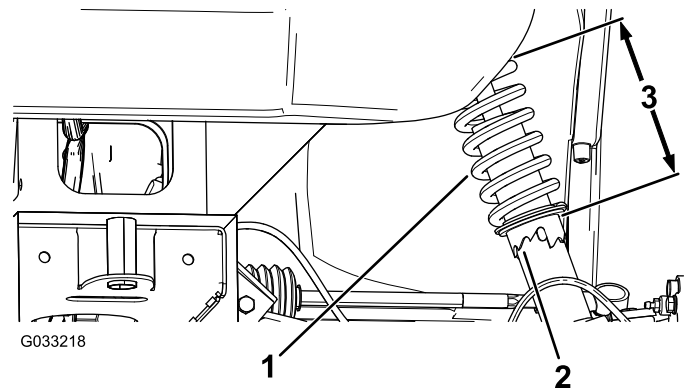

Figure 50

G033218

g033218

1. Shock-absorber spring
2. Collar
3. Spring length

Adjusting the Front Wheel Toe-in

Important: Before adjusting toe-in, ensure that the camber adjustment is as close to neutral as possible; refer to [Adjusting the Camber \(page 41\)](#).

1. Measure the distance between both of the front tires at the axle height at both the front and rear of the front tires ([Figure 51](#)).

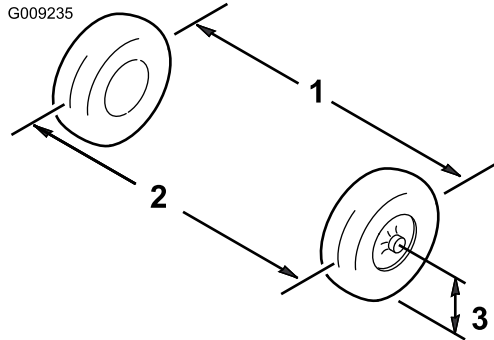

Figure 51

1. Tire center line—back
2. Tire center line—front
3. Axle center line

2. If the measurement does not fall within 0 to 6 mm (0 to 1/4 inch), loosen the jam nuts at the outer end of the tie rods ([Figure 52](#)).

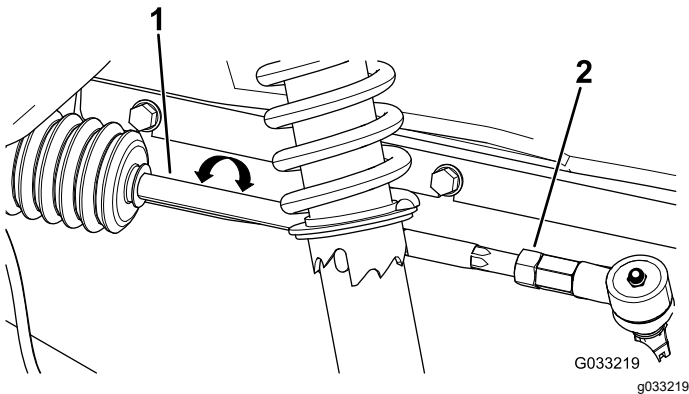

Figure 52

1. Tie rod
2. Jam nut

3. Rotate both tie rods to move the front of the tire inward or outward.
4. Tighten the tie rod jam nuts when the adjustment is correct.
5. Ensure that there is full travel of the steering wheel in both directions.

Checking the Transaxle-Fluid Level

Service Interval: Every 100 hours—Check the transaxle-fluid level.

1. Park the machine on a level surface.
2. Engage the parking brake.
3. Shut off the motor and remove the key.
4. Remove the fill plug on the transaxle ([Figure 53](#)).

Note: The fluid level should be even with the bottom of the fill plug.

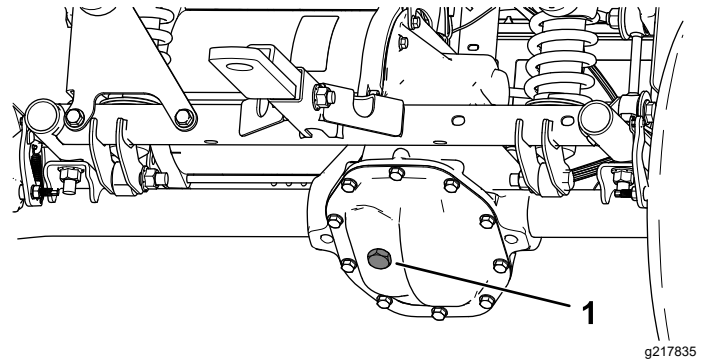

Figure 53

1. Fill plug

5. If the fluid level is low, remove the fill plug and add the specified fluid until it runs out of the hole ([Figure 53](#)).
6. Install the fill plug and torque it to 20 to 27 N·m (15 to 20 ft-lb).

Changing the Transaxle Fluid

Service Interval: Every 100 hours—Check the transaxle for leaks.

Every 800 hours/Yearly (whichever comes first)—Change the transaxle fluid.

Fluid Type: SAE 10W-30 (API service SJ or higher)

Fluid Capacity: 0.66 L (0.7 US qt)

1. Align a drain pan under the transaxle cover (Figure 54).

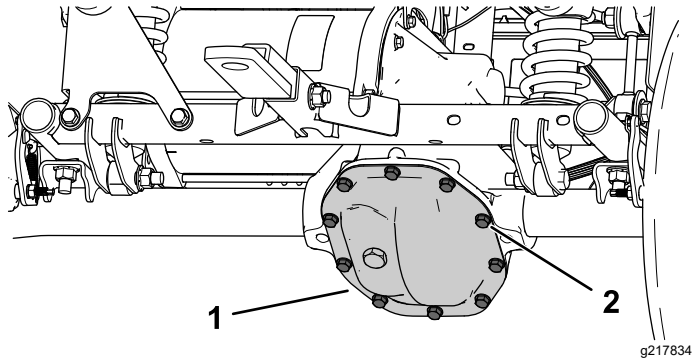

Figure 54

g217834

1. Transaxle cover

2. Bolts

2. Remove the bolts from the transaxle cover and drain the fluid completely (Figure 54).

Note: Retain the transaxle cover and bolt.

3. Install the transaxle cover using the previously removed bolts, and torque the bolts to 22 to 32 N·m (16 to 24 ft-lb).
4. Remove the fill plug on the transaxle and fill the transaxle with the specified fluid until it runs out of the fill hole (Figure 53).
5. Install the fill plug and torque it to 20 to 27 N·m (15 to 20 ft-lb).

Brake Maintenance

Checking the Parking Brake

1. Engage the parking brake by pulling the parking-brake lever toward you, until you feel tension.
2. If you do not feel tension when pulling the parking-brake toward you within 11.4 to 16.5 cm (4-1/2 to 6-1/2 inches) from the “P” symbol on the dash, then you need to adjust the parking brake; refer to [Adjusting the Parking Brake](#) (page 43).

Adjusting the Parking Brake

1. Ensure that the parking brake is disengaged.
2. Using jack stands, lift the rear of the machine; refer to [Lifting the Machine](#) (page 31).
3. Using 2 wrenches, hold the adjusting post on the caliper in place with 1 wrench, and loosen the jam nut 1/4 turn with the other wrench (Figure 55).

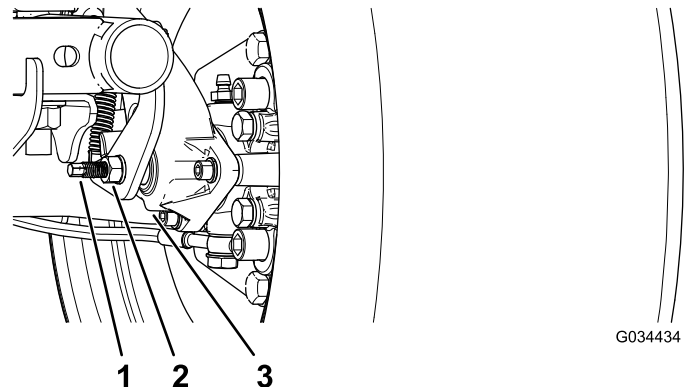

G034434

g034434

Figure 55

1. Adjusting post

3. Caliper

2. Jam nut

4. While holding the adjusting post and the jam nut in place, turn the adjusting post in to tighten (Figure 55).

Note: Perform this step until you feel drag on the wheel.

5. While holding the adjusting post and the jam nut in place, back off 1/4 turn (Figure 55).
6. While holding the adjusting post and the jam nut in place, tighten the jam nut (Figure 55).
7. Perform steps 1 through 6 to the other side.

8. Verify that the parking brake is adjusted to the proper tension; refer to [Checking the Parking Brake \(page 43\)](#).

Note: If you cannot adjust the parking brake to the required tension, the brake pads may be worn and need to be replaced. Contact your authorized Toro distributor for assistance.

Checking the Brake-Fluid Level

Service Interval: Before each use or daily Check the brake-fluid level before the motor is first used.

Brake Fluid Type: DOT 3

1. Park the machine on a level surface, engage the parking brake, shut off the machine, and remove the key.
2. Raise the hood to gain access to the master-brake cylinder and reservoir ([Figure 56](#)).

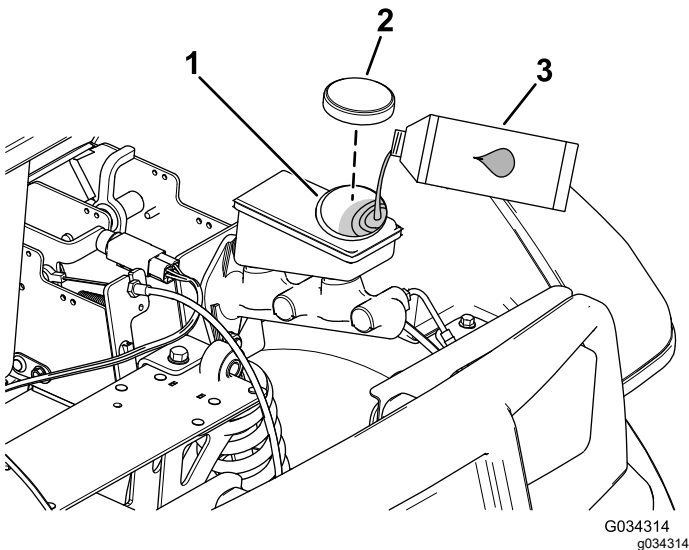

Figure 56

1. Filler neck (reservoir)
2. Reservoir cap
3. DOT 3 brake fluid

3. Look at the outline of the fluid level at the side of the reservoir ([Figure 57](#)).

Note: The level should be above the Minimum line.

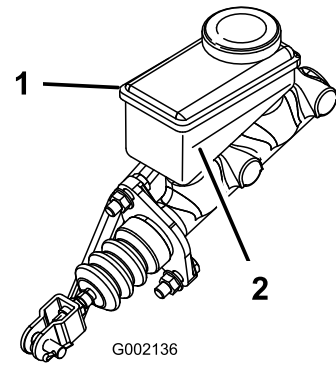

Figure 57

1. Brake-fluid reservoir
2. Minimum line

4. If the fluid level is low, perform the following:
 - A. Clean the area around the reservoir cap and remove the cap ([Figure 56](#)).
 - B. Add DOT 3 brake fluid to the reservoir until the fluid level is above the Minimum line ([Figure 57](#)).

Note: Do not overfill the reservoir with brake fluid.
 - C. Install the reservoir cap ([Figure 56](#)).
5. Close the hood of the machine.

Inspecting the Brakes

Service Interval: Every 100 hours

Important: Brakes are a critical safety component of the machine. Closely inspect them at the recommended service interval to ensure optimum performance and safety.

- Inspect the brake lining for wear or damage. If the lining (brake pad) thickness is less than 1.6 mm (1/16 inch), replace the brake lining.
- Inspect the backing plate and other components for signs of excessive wear or deformation. Replace any deformed components.
- Check the brake-fluid level; refer to [Checking the Brake-Fluid Level \(page 44\)](#).

Replacing the Service and Parking-Brake Pads

Service Interval: Every 400 hours

Contact your authorized Toro distributor to inspect and possibly replace the service and parking-brake pads.

Changing the Brake Fluid

Service Interval: Every 1,000 hours

Contact your authorized Toro distributor.

Chassis Maintenance

Adjusting the Cargo-Bed Latches

If the cargo-bed latch is out of adjustment, the cargo bed vibrates up and down as you drive the machine. You can adjust the latch posts to make the latches hold the cargo bed snugly to the chassis.

1. Verify that the cargo bed is latching.

Note: If the cargo bed does not latch, the bed-latch striker is likely too low. If the cargo bed latches, but vibrates up and down as you drive, the bed-latch striker is likely too high.

2. Raise the cargo bed; [Raising the Cargo Bed to the Dump Position \(page 19\)](#).
3. Loosen the 2 bolts on the bed-latch striker and move the striker up or down, depending on if the striker is too high or too low ([Figure 58](#)).

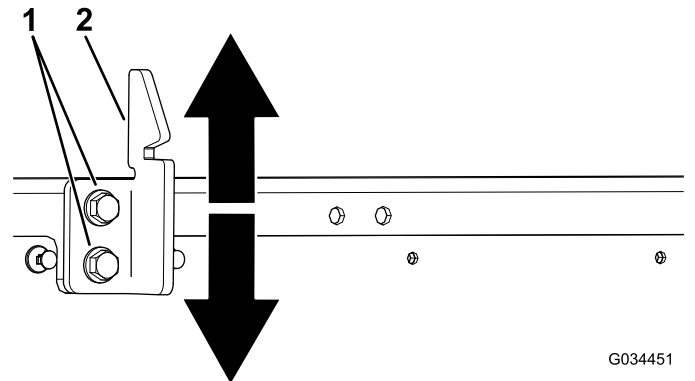

Figure 58

1. Bolts
2. Bed-latch striker

4. Tighten the 2 bolts on the bed-latch striker ([Figure 58](#)).
5. Verify that the adjustment is correct by latching the cargo bed several times.

Cleaning

Washing the Machine

Service Interval: Before each use or daily—Wash the machine.

Wash the machine as needed using water alone or with a mild detergent. You may use a rag when washing the machine.

Important: Do not use brackish or reclaimed water to clean the machine.

Important: Pressurized water is not recommended when washing the machine. It may damage the electrical system, loosen important decals, or wash away necessary grease at friction points. Avoid excessive use of water, especially near the control panel, motor, motor controller, charger, back of the dashboard, and batteries.

Storage

Storage Safety

- Shut off the machine, remove the key, and wait for all movement to stop before you leave the operator's position. Allow the machine to cool before adjusting, servicing, cleaning, or storing it.
- Do not store the machine or fuel container where there is an open flame, spark, or pilot light, such as on a water heater or other appliance.

Storing the Machine

1. Park the machine on a level surface, engage the parking brake, shut off the machine, and remove the key.
2. Clean dirt and grime from the entire machine, including the outside of the motor housing.

Important: You can wash the machine with mild detergent and water. Do not use high-pressure water to wash the machine. Pressure-washing may damage the electrical system or wash away necessary grease at friction points. Avoid excessive use of water, especially near the control panel, lights, motor, and battery.

3. Inspect the brakes; refer to [Inspecting the Brakes \(page 44\)](#).
4. Check the tire pressure; refer to [Checking the Tire Pressure \(page 16\)](#).
5. Check and tighten all bolts, nuts, and screws. Repair or replace any part that is damaged.
6. Paint all scratched or bare metal surfaces.
Note: Paint is available from your authorized Toro distributor.
7. Cover the machine to protect it and keep it clean.

Battery Storage Requirements

does not turn back on unless the charger is disconnected and reconnected.

Note: You do not need to remove the batteries from the machine for storage.

Refer to the temperature requirements for storage in the following table:

Temperature Requirements for Storage

Storage Conditions	Temperature Requirement
Normal storage conditions	-20° to 45°C (-12° to 113°F)
Extreme heat—1 month or less	45° to 60°C (113° to 140°F)
Extreme cold—3 months or less	-30° to -20°C (-22° to -12°F)

Important: Temperatures outside of this range will damage your batteries.

The temperature that the batteries are stored at will affect their long-term life. Storage for long periods of time at extreme temperatures will reduce the battery life. Store the machine in the normal storage conditions indicated in the temperature-requirements table.

- Before you store the machine, charge or discharge the batteries between 40% to 60% (50.7V to 52.1V).

Note: A 50% charge is optimal to ensure a maximum battery life. When the batteries are charged to 100% before storage, the battery life shortens.

If you anticipate that the machine will be stored for a longer period of time, charge the batteries to around 60%.

- For every 6 months of storage, check the battery-charge level and ensure that it is between 40% to 60%. If the charge is below 40%, charge the batteries between 40% to 60%.
- You can use a multimeter to check the charge level when the machine is off. Refer to the following table for the amount of voltage that is equal to the charge level:

Voltage	Charge Level
52.1V	60%
51.4V	50%
50.7V	40%

- After charging the batteries, disconnect the battery charger from power. Disconnect the power connector during storage to minimize the discharging of the batteries.
- If you leave the charger on the machine, it will shut off after the batteries are fully charged and

Troubleshooting

Battery Charger Error Codes

Problem	Possible Cause	Corrective Action
Code E-0-0-1, or E-0-4-7	1. Battery high voltage	1. Ensure that the battery voltage is correct and the cable connections are secure; ensure that the battery is in good condition.
Code E-0-0-4	1. BMS or battery fault detected	1. Contact an authorized Toro distributor.
Code E-0-0-7	1. Battery amp hour limit exceeded	1. Possible causes include poor battery health, very deeply discharged battery, poorly connected battery, and/or high parasitic loads on battery while charging. Possible solutions: Replace batteries. Check DC connections. Disconnect parasitic loads. This error will clear once the charger is reset by cycling DC.
Code E-0-1-2	1. Reverse polarity error	1. The battery is connected to the charger incorrectly. Ensure that the battery connections are secure.
Code E-0-2-3	1. High AC voltage error (>270VAC)	1. Connect charger to an AC source that provides stable AC between 85 - 270 VAC / 45-65 Hz.
Code E-0-2-4	1. Charger failed to initialize	1. The charger failed to turn on properly. Disconnect the AC input and battery connection for 30 seconds before retrying.
Code E-0-2-5	1. Low AC voltage oscillation error	1. The AC source is unstable. Could be caused by undersized generator or severely undersized input cables. Connect charger to an AC source that provides stable AC between 85 - 270 VAC / 45-65 Hz.
Code E-0-3-7	1. Re-programming failed	1. Software upgrade failure or script operation failure. Ensure that the new software is correct.
Code E-0-2-9, E-0-3-0, E-0-3-2, E-0-4-6, or E-0-6-0	1. Communication error with battery	1. Ensure that the connection of the signal wires to the battery is secure.

Battery Charger Fault Codes

Problem	Possible Cause	Corrective Action
F-0-0-1, F-0-0-2, F-0-0-3, F-0-0-4, F-0-0-5, F-0-0-6, or F-0-0-7	1. Internal charger fault	1. Remove the AC connection and battery connection for a minimum of 30 seconds and retry. If it fails again, please contact an authorized Toro distributor.

Machine Fault Codes

Problem	Possible Cause	Corrective Action
Code P156C, P156E	1. There is a controller-configuration fault.	1. Contact your authorized Toro distributor.
Code P0226, P156C, B1107	1. The parking brake is engaged while in FORWARD or REVERSE position. 2. A drive-switch fault occurred.	1. Disengage the parking brake. 2. Turn off the machine and check the functionality of the switches.
Code P0A54, P156C	1. The motor current exceeded the controller-rated maximum. 2. There is an internal-power component fault.	1. Turn the key switch to the OFF position, wait a few seconds, and turn the key switch to the ON position. Check all batteries and high-current controller connections. If the condition continues, refer to your authorized Toro distributor. 2. Contact your authorized Toro distributor.
Code P2BE8, P2BE9	1. A main-contactor fault occurred.	1. Test the contact wires, coil and contacts for normal operation.
Code P0A44	1. Exceeded the maximum motor speed.	1. Turn the key switch to the OFF position, wait a few seconds, turn the key switch to the ON position, and check for normal operation.
Code P0226, P156C	1. The throttle is pressed while starting the machine. 2. There is a wire that is not making a connection.	1. Release the pedal, turn the key switch to the OFF position, wait a few seconds, turn the key switch to the ON position, and check for normal operation. 2. Test the wiring between the controller and contactor, switches, and the status-indicator light.
Code P0E8E, P156C	1. The remaining charge on the batteries is low. 2. The batteries are fully discharged. 3. The internal capacitor has a pre-charge of less than 5V.	1. Stop operation, drive slowly to your nearest charging station, and charge the batteries fully. 2. Tow the machine to your charging station and charge the batteries fully. 3. Fully charge the batteries, turn the key switch to the OFF position, wait a few seconds, turn the key switch to the ON position, and check for normal operation.
Code P0A2F, P0A3C, P1502, P1511, P1512	1. The controller or motor is overheated or too cold.	1. Determine if the motor or controller is very hot or very cold, then allow the machine to return to safe temperatures before resuming normal operation.
Code P0A44, P1520	1. A motor-encoder fault occurred. 2. Exceeded the maximum motor speed.	1. Check the motor-encoder (speed sensor) wiring. 2. Turn the key switch to the OFF position, wait a few seconds, turn the key switch to the ON position, and check for normal operation.
Code P156D	1. An internal-software fault occurred.	1. Contact your authorized Toro distributor.

Notes:

EEA/UK Privacy Notice

Toro's Use of Your Personal Information

The Toro Company ("Toro") respects your privacy. When you purchase our products, we may collect certain personal information about you, either directly from you or through your local Toro company or dealer. Toro uses this information to fulfil contractual obligations - such as to register your warranty, process your warranty claim or to contact you in the event of a product recall - and for legitimate business purposes - such as to gauge customer satisfaction, improve our products or provide you with product information which may be of interest. Toro may share your information with our subsidiaries, affiliates, dealers or other business partners in connection these activities. We may also disclose personal information when required by law or in connection with the sale, purchase or merger of a business. We will never sell your personal information to any other company for marketing purposes.

Retention of your Personal Information

Toro will keep your personal information as long as it is relevant for the above purposes and in accordance with legal requirements. For more information about applicable retention periods please contact legal@toro.com.

Toro's Commitment to Security

Your personal information may be processed in the US or another country which may have less strict data protection laws than your country of residence. Whenever we transfer your information outside of your country of residence, we will take legally required steps to ensure that appropriate safeguards are in place to protect your information and to make sure it is treated securely.

Access and Correction

You may have the right to correct or review your personal data, or object to or restrict the processing of your data. To do so, please contact us by email at legal@toro.com. If you have concerns about the way in which Toro has handled your information, we encourage you to raise this directly with us. Please note that European residents have the right to complain to your Data Protection Authority.

California Proposition 65 Warning Information

What is this warning?

You may see a product for sale that has a warning label like the following:



WARNING: Cancer and Reproductive Harm—www.p65Warnings.ca.gov.

What is Prop 65?

Prop 65 applies to any company operating in California, selling products in California, or manufacturing products that may be sold in or brought into California. It mandates that the Governor of California maintain and publish a list of chemicals known to cause cancer, birth defects, and/or other reproductive harm. The list, which is updated annually, includes hundreds of chemicals found in many everyday items. The purpose of Prop 65 is to inform the public about exposure to these chemicals.

Prop 65 does not ban the sale of products containing these chemicals but instead requires warnings on any product, product packaging, or literature with the product. Moreover, a Prop 65 warning does not mean that a product is in violation of any product safety standards or requirements. In fact, the California government has clarified that a Prop 65 warning "is not the same as a regulatory decision that a product is 'safe' or 'unsafe.'" Many of these chemicals have been used in everyday products for years without documented harm. For more information, go to <https://oag.ca.gov/prop65/faqs-view-all>.

A Prop 65 warning means that a company has either (1) evaluated the exposure and has concluded that it exceeds the "no significant risk level"; or (2) has chosen to provide a warning based on its understanding about the presence of a listed chemical without attempting to evaluate the exposure.

Does this law apply everywhere?

Prop 65 warnings are required under California law only. These warnings are seen throughout California in a wide range of settings, including but not limited to restaurants, grocery stores, hotels, schools, and hospitals, and on a wide variety of products. Additionally, some online and mail order retailers provide Prop 65 warnings on their websites or in catalogs.

How do the California warnings compare to federal limits?

Prop 65 standards are often more stringent than federal and international standards. There are various substances that require a Prop 65 warning at levels that are far lower than federal action limits. For example, the Prop 65 standard for warnings for lead is 0.5 µg/day, which is well below the federal and international standards.

Why don't all similar products carry the warning?

- Products sold in California require Prop 65 labelling while similar products sold elsewhere do not.
- A company involved in a Prop 65 lawsuit reaching a settlement may be required to use Prop 65 warnings for its products, but other companies making similar products may have no such requirement.
- The enforcement of Prop 65 is inconsistent.
- Companies may elect not to provide warnings because they conclude that they are not required to do so under Prop 65; a lack of warnings for a product does not mean that the product is free of listed chemicals at similar levels.

Why does Toro include this warning?

Toro has chosen to provide consumers with as much information as possible so that they can make informed decisions about the products they buy and use. Toro provides warnings in certain cases based on its knowledge of the presence of one or more listed chemicals without evaluating the level of exposure, as not all the listed chemicals provide exposure limit requirements. While the exposure from Toro products may be negligible or well within the "no significant risk" range, out of an abundance of caution, Toro has elected to provide the Prop 65 warnings. Moreover, if Toro does not provide these warnings, it could be sued by the State of California or by private parties seeking to enforce Prop 65 and subject to substantial penalties.



Battery Limited Warranty

Battery

The rechargeable Lithium-Ion battery is warranted to be free from defects in materials and workmanship for a period of 5 years. Over time, battery consumption reduces the amount of energy capacity (Amp-hours) available per full charge. Energy consumption varies due to operating characteristics, accessories, turf, terrain, adjustments, and temperature.

Product	Warranty Period
Workman GTX	5 years
eTriFlex	4 years
Greensmaster	4 years



The Toro Warranty

Two-Year or 1,500 Hours Limited Warranty

Conditions and Products Covered

The Toro Company warrants your Toro Commercial product ("Product") to be free from defects in materials or workmanship for 2 years or 1,500 operational hours*, whichever occurs first. This warranty is applicable to all products with the exception of Aerators (refer to separate warranty statements for these products). Where a warrantable condition exists, we will repair the Product at no cost to you including diagnostics, labor, parts, and transportation. This warranty begins on the date the Product is delivered to the original retail purchaser.

* Product equipped with an hour meter.

Instructions for Obtaining Warranty Service

You are responsible for notifying the Commercial Products Distributor or Authorized Commercial Products Dealer from whom you purchased the Product as soon as you believe a warrantable condition exists. If you need help locating a Commercial Products Distributor or Authorized Dealer, or if you have questions regarding your warranty rights or responsibilities, you may contact us at:

Toro Commercial Products Service Department
8111 Lyndale Avenue South
Bloomington, MN 55420-1196

952-888-8801 or 800-952-2740
E-mail: commercial.warranty@toro.com

Owner Responsibilities

As the product owner, you are responsible for required maintenance and adjustments stated in your *Operator's Manual*. Repairs for product issues caused by failure to perform required maintenance and adjustments are not covered under this warranty.

Items and Conditions Not Covered

Not all product failures or malfunctions that occur during the warranty period are defects in materials or workmanship. This warranty does not cover the following:

- Product failures which result from the use of non-Toro replacement parts, or from installation and use of add-on, or modified non-Toro branded accessories and products.
- Product failures which result from failure to perform recommended maintenance and/or adjustments.
- Product failures which result from operating the Product in an abusive, negligent, or reckless manner.
- Parts consumed through use that are not defective. Examples of parts which are consumed, or used up, during normal Product operation include, but are not limited to, brake pads and linings, clutch linings, blades, reels, rollers and bearings (sealed or greasable), bed knives, spark plugs, castor wheels and bearings, tires, filters, belts, and certain sprayer components such as diaphragms, nozzles, flow meters, and check valves.
- Failures caused by outside influence, including, but not limited to, weather, storage practices, contamination, use of unapproved fuels, coolants, lubricants, additives, fertilizers, water, or chemicals.
- Failure or performance issues due to the use of fuels (e.g. gasoline, diesel, or biodiesel) that do not conform to their respective industry standards.
- Normal noise, vibration, wear and tear, and deterioration. Normal "wear and tear" includes, but is not limited to, damage to seats due to wear or abrasion, worn painted surfaces, scratched decals or windows.

Countries Other than the United States or Canada

Customers who have purchased Toro products exported from the United States or Canada should contact their Toro Distributor (Dealer) to obtain guarantee policies for your country, province, or state. If for any reason you are dissatisfied with your Distributor's service or have difficulty obtaining guarantee information, contact your Authorized Toro Service Center.

Parts

Parts scheduled for replacement as required maintenance are warranted for the period of time up to the scheduled replacement time for that part. Parts replaced under this warranty are covered for the duration of the original product warranty and become the property of Toro. Toro will make the final decision whether to repair any existing part or assembly or replace it. Toro may use remanufactured parts for warranty repairs.

Deep Cycle and Lithium-Ion Battery Warranty

Deep cycle and Lithium-Ion batteries have a specified total number of kilowatt-hours they can deliver during their lifetime. Operating, recharging, and maintenance techniques can extend or reduce total battery life. As the batteries in this product are consumed, the amount of useful work between charging intervals will slowly decrease until the battery is completely worn out. Replacement of worn out batteries, due to normal consumption, is the responsibility of the product owner. Note: (Lithium-Ion battery only): Refer to the battery warranty for additional information.

Lifetime Crankshaft Warranty (ProStripe 02657 Model Only)

The ProStripe which is fitted with a genuine Toro Friction Disc and Crank-Safe Blade Brake Clutch (integrated Blade Brake Clutch (BBC) + Friction Disc assembly) as original equipment and used by the original purchaser in accordance with recommended operating and maintenance procedures, are covered by a Lifetime Warranty against engine crankshaft bending. Machines fitted with friction washers, Blade Brake Clutch (BBC) units and other such devices are not covered by the Lifetime Crankshaft Warranty.

Maintenance is at Owner's Expense

Engine tune-up, lubrication, cleaning and polishing, replacement of filters, coolant, and completing recommended maintenance are some of the normal services Toro products require that are at the owner's expense.

General Conditions

Repair by an Authorized Toro Distributor or Dealer is your sole remedy under this warranty.

The Toro Company is not liable for indirect, incidental or consequential damages in connection with the use of the Toro Products covered by this warranty, including any cost or expense of providing substitute equipment or service during reasonable periods of malfunction or non-use pending completion of repairs under this warranty. Except for the Emissions warranty referenced below, if applicable, there is no other express warranty. All implied warranties of merchantability and fitness for use are limited to the duration of this express warranty.

Some states do not allow exclusions of incidental or consequential damages, or limitations on how long an implied warranty lasts, so the above exclusions and limitations may not apply to you. This warranty gives you specific legal rights, and you may also have other rights which vary from state to state.

Note Regarding Emissions Warranty

The Emissions Control System on your Product may be covered by a separate warranty meeting requirements established by the U.S. Environmental Protection Agency (EPA) and/or the California Air Resources Board (CARB). The hour limitations set forth above do not apply to the Emissions Control System Warranty. Refer to the Engine Emission Control Warranty Statement supplied with your product or contained in the engine manufacturer's documentation.



Count on it.