



Count on it.

Operator's Manual

LT3340 4 Wheel Drive Triple Reel Mower

Model No. 31657—Serial No. 41440000 and Up

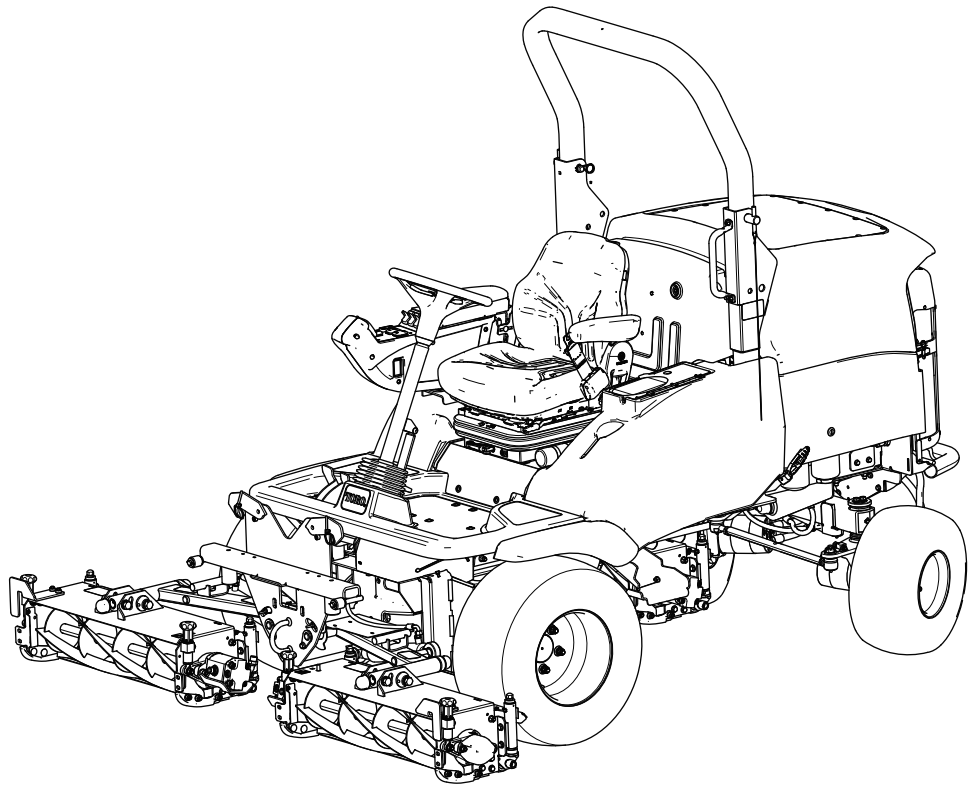

This product complies with all relevant European directives; for details, please see the separate product specific Declaration of Conformity (DOC) sheet.

This manual identifies potential hazards and has safety messages identified by the safety-alert symbol (Figure 2), which signals a hazard that may cause serious injury or death if you do not follow the recommended precautions.

Introduction

This machine is a ride-on, reel-blade lawn mower intended to be used by professional, hired operators in commercial applications. It is primarily designed for cutting grass on well-maintained turf. Using this product for purposes other than its intended use could prove dangerous to you and bystanders.

Read this information carefully to learn how to operate and maintain your product properly and to avoid injury and product damage. You are responsible for operating the product properly and safely.

Visit www.toro.com/en-gb for more information, including safety tips, training materials, accessory information, help finding a dealer, or to register your product.

Whenever you need service, genuine Toro parts, or additional information, contact an Authorized Service Dealer or Toro Customer Service and have the model and serial numbers of your product ready. Figure 1 identifies the location of the model and serial numbers on the product. Write the numbers in the space provided.

Important: With your mobile device, you can scan the QR code on the serial number decal (if equipped) to access warranty, parts, and other product information.

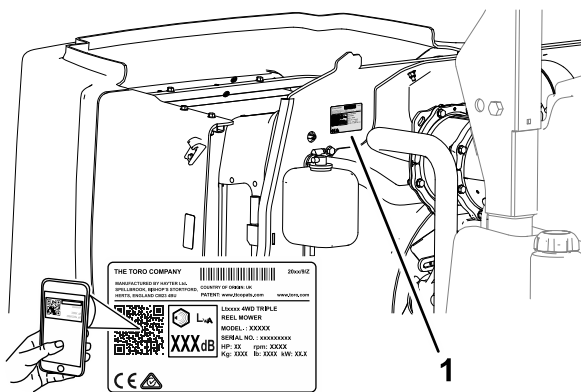

Figure 1

g329968

1. Model and serial number location

Model No.	_____
Serial No.	_____



Figure 2

Safety-alert symbol

g000502

This manual uses 2 words to highlight information. **Important** calls attention to special mechanical information and **Note** emphasizes general information worthy of special attention.

Contents

Safety	4
General Safety	4
Safety and Instructional Decals	4
Setup	9
Product Overview	9
Controls	9
Operator's Seat Controls	11
Transport Latches	13
Specifications	18
Attachments/Accessories	18
Before Operation	19
Before Operation Safety	19
Performing Daily Maintenance	20
Filling the Fuel Tank	20
Checking the Forward/Reverse Traction Pedal Action	21
Checking the Interlock Switches	21
During Operation	22
During Operation Safety	22
Understanding the Operator Presence Controls	23
Adjusting the Roll Bar	24
Starting the Engine	25
Shutting Off the Engine	25
Using the Cutting Units	26
Controlling the Position of the Individual Cutting Units	26
Adjusting the Cutting Unit Auto-Limited Lift	27
Cutting Unit Drive	27
Adjusting the Weight Transfer/Traction Assistance	28
Clearing the Cutting Units	29
Operating Tips	29
After Operation	30
After Operation Safety	30

Identifying the Tie-Down Points	30	Hydraulic System Maintenance	53
Hauling the Machine	30	Hydraulic System Safety	53
Towing the Machine	30	Checking the Hydraulic Lines and	
Maintenance	34	Hoses	53
Maintenance Safety	34	Hydraulic Fluid Specifications	53
Recommended Maintenance Schedule(s)	34	Checking the Hydraulic Fluid Level	53
Daily Maintenance Checklist	36	Changing the Hydraulic Return Filter	54
Notation for Areas of Concern	36	Changing the Hydraulic Fluid	54
Pre-Maintenance Procedures	37	Cutting Unit Maintenance	56
Raising the Platform	37	Blade Safety	56
Lowering the Platform	37	Backlapping the Cutting Units	56
Removing the Storage Compartment	38	Grinding the Cutting Units	57
Installing the Storage Compartment	38	Chassis Maintenance	57
Locating the Lift Points	39	Inspecting the Seat Belt	57
Lubrication	40	Checking the Fasteners	57
Greasing the Bearings, Bushings, and		Extended Maintenance	57
Pivots	40	Cleaning	58
Engine Maintenance	41	Washing the Machine	58
Engine Safety	41	Storage	58
Checking the Air Filter-Blockage		Storage Safety	58
Indicator	41	Preparing the Traction Unit	58
Replacing the Primary Air Filter	41	Preparing the Engine	59
Replacing the Safety Filter	42	Preparing the Electrical System	59
Servicing the Engine Oil	42	Troubleshooting	60
Servicing the Diesel-Oxidation Catalyst			
(DOC) and the Soot Filter	43		
Extended Engine Maintenance	44		
Fuel System Maintenance	44		
Fuel Maintenance	44		
Storing Fuel	45		
Servicing the Water Separator	45		
Priming the Fuel System	45		
Replacing the Fuel-Water Filter	45		
Servicing the Engine Fuel Filter	46		
Checking the Fuel Lines and			
Connections	46		
Fuel Pick-up Tube Screen	46		
Electrical System Maintenance	47		
Electrical System Safety	47		
Battery Maintenance	47		
Checking the Electrical System	47		
Checking the Fuses	47		
Drive System Maintenance	48		
Checking the Tire Air Pressure	48		
Checking the Torque of the Wheel			
Nuts	48		
Inspecting the Transmission Control Cable			
and Operating Mechanism	49		
Checking the Rear Wheel Alignment	49		
Adjusting Rear Wheel Toe-In	49		
Cooling System Maintenance	50		
Cooling System Safety	50		
Coolant Specification	50		
Checking the Coolant Level	51		
Removing Debris from the Cooling			
System	51		
Belt Maintenance	52		
Servicing the Alternator Belt	52		

Safety

This machine has been designed in accordance with EN ISO 5395.

General Safety

This product is capable of amputating hands and feet and of throwing objects.

- Read and understand the contents of this *Operator's Manual* before starting the engine.
- Use your full attention while operating the machine. Do not engage in any activity that causes distractions; otherwise, injury or property damage may occur.
- Do not put your hands or feet near moving components of the machine.

- Do not operate the machine without all guards and other safety protective devices in place and functioning properly on the machine.
- Keep bystanders and children out of the operating area. Never allow children to operate the machine.
- Shut off the engine, remove the key, and wait for all movement to stop before you leave the operator's position. Allow the machine to cool before adjusting, servicing, cleaning, or storing it.

Improperly using or maintaining this machine can result in injury. To reduce the potential for injury, comply with these safety instructions and always pay attention to the safety-alert symbol **▲**, which means Caution, Warning, or Danger—personal safety instruction. Failure to comply with these instructions may result in personal injury or death.

Safety and Instructional Decals



Safety decals and instructions are easily visible to the operator and are located near any area of potential danger. Replace any decal that is damaged or missing.



decal93-6686

93-6686

1. Hydraulic fluid
2. Read the *Operator's Manual*.

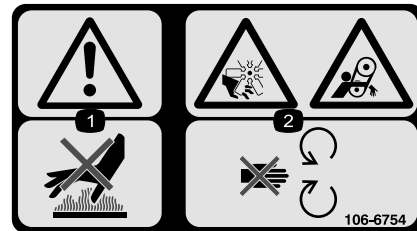

decal106-6754

106-6754

1. Warning—do not touch the hot surface.
2. Cutting/dismemberment hazard, fan; entanglement hazard, belt—stay away from moving parts.

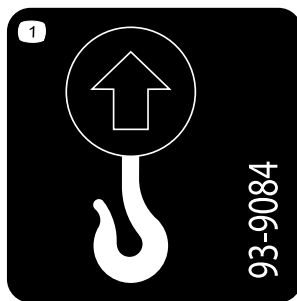

decal93-9084

93-9084

1. Lift point/Tie-down point



decal106-6755

106-6755

1. Engine coolant under pressure.
2. Explosion hazard—read the *Operator's Manual*.
3. Warning—do not touch the hot surface.
4. Warning—read the *Operator's Manual*.



111-3562

decal111-3562

1. Press the pedal to adjust the steering wheel angle.

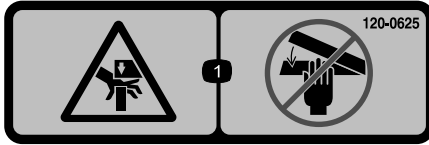

120-0625

decal120-0625

1. Pinch point, hand—keep hands away.

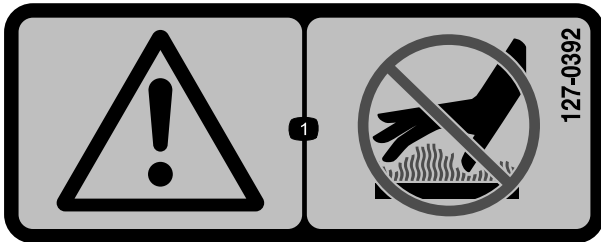

127-0392

decal127-0392

1. Warning—stay away from hot surfaces.

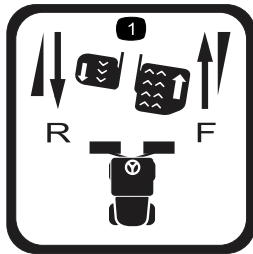

111-3567

decal111-3567

1. Pedal operation

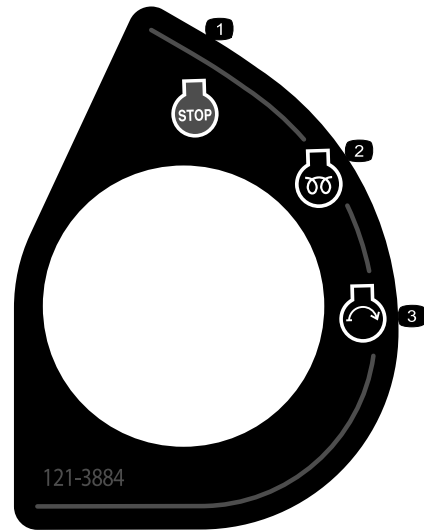

121-3884

decal121-3884

1. Engine—stop
2. Engine—preheat
3. Engine—start

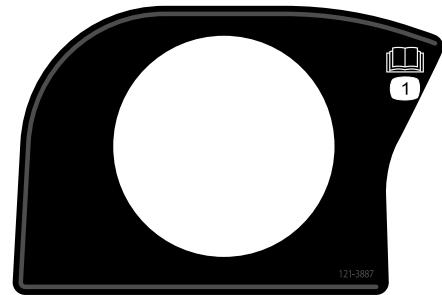

121-3887

decal121-3887

1. Read the *Operator's Manual*.

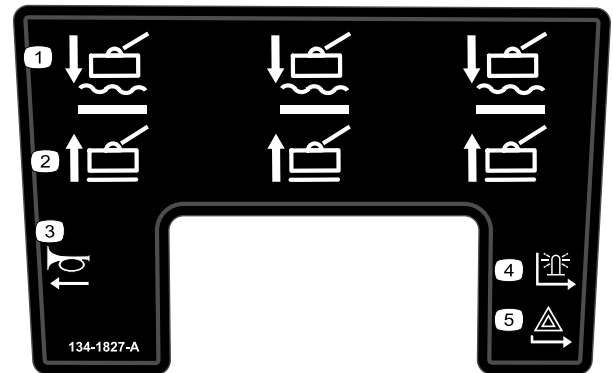

134-1827

decal134-1827

1. Cutting units—lower/float
2. Cutting units—raise
3. Horn
4. Beacon
5. Hazard warning light

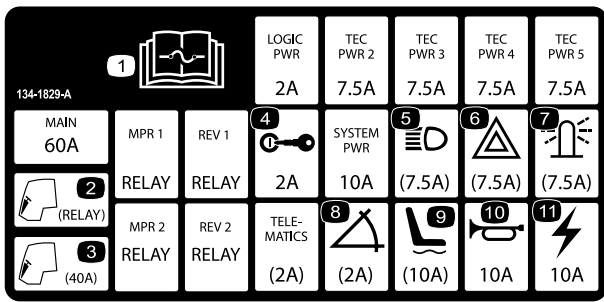

134-1829

decal134-1829

1. Read the *Operator's Manual* for information on fuses.
2. Cab—relay
3. Cab—40 A
4. Key switch—2 A
5. Headlights—7.5 A
6. Hazard warning light—7.5 A
7. Beacon—7.5 A
8. Slope sensor—2 A
9. Power seat—10 A
10. Horn—10 A
11. Power—10 A

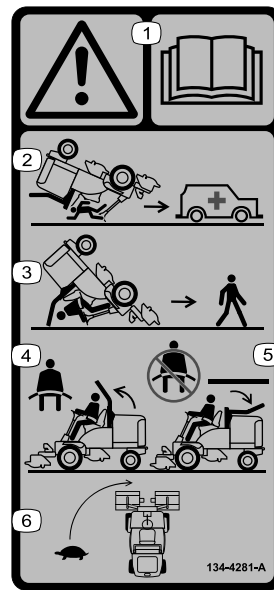

134-4281

decal134-4281

1. Warning—read the *Operator's Manual*.
2. There is no rollover protection when the roll bar is down.
3. There is rollover protection when the roll bar is up.
4. If the roll bar is raised, wear the seat belt.
5. If the roll bar is not raised, do not wear the seat belt.
6. Drive slowly when turning.

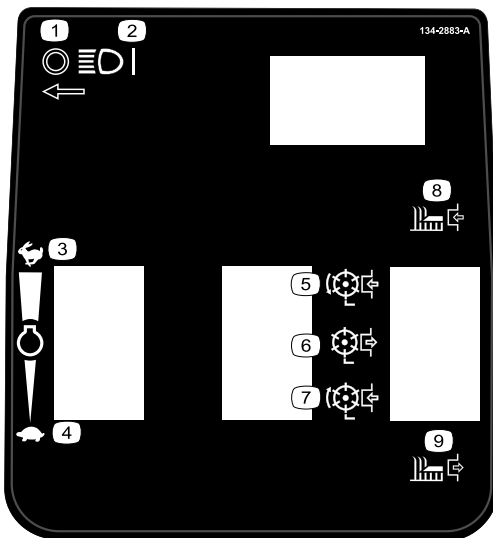

134-2883

decal134-2883

1. Headlights—off
2. Headlights—on
3. Engine speed—fast
4. Engine speed—slow
5. Cutting unit drive—forward
6. Cutting unit drive—off
7. Cutting unit drive—reverse
8. Cutting unit—on
9. Cutting unit—off

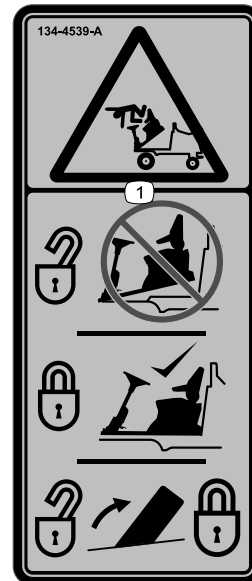

134-4539

decal134-4539

1. Falling, crushing hazard—ensure that the operator-platform latch is engaged before operating.

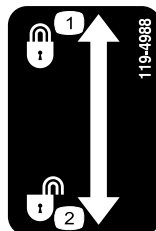

119-4988

decal119-4988

1. Lock
2. Unlock

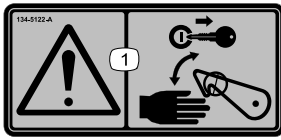

134-5122

decal134-5122

1. Warning—shut off the engine and remove the key before releasing or operating the safety latches.

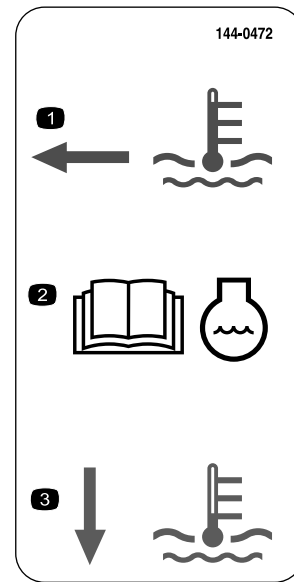

144-0472

decal144-0472

1. The coolant level is hot.
2. Read the *Operator's Manual* for coolant information.
3. The coolant level is cold.

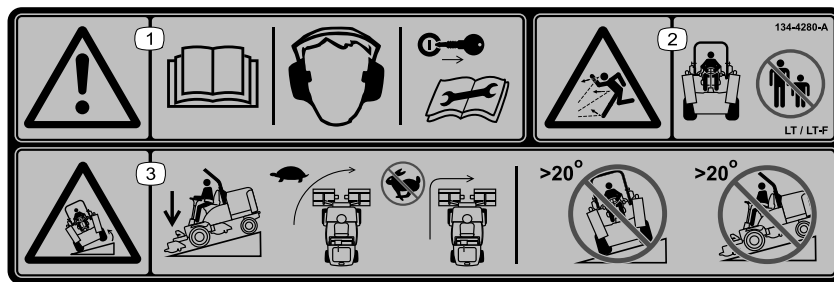

134-4280

decal134-4280

Note: This machine complies with the industry standard stability test in the static lateral and longitudinal tests with the maximum recommended slope indicated on the decal. Review the instructions for operating the machine on slopes in the *Operator's Manual* as well as the conditions in which you would operate the machine to determine whether you can operate the machine in the conditions on that day and at that site. Changes in the terrain can result in a change in slope operation for the machine.

1. Warning—read the *Operator's Manual*; wear hearing protection; remove the key before performing maintenance.
2. Thrown object hazard—keep bystanders away.
3. Tipping hazard—lower the cutting units when driving downhill; drive slowly when turning; do not turn sharply while traveling fast; do not operate on slopes greater than 20°.

The decal is divided into two main sections. The left section contains 17 numbered icons representing maintenance tasks: 1. 8H service interval, 2. Reading the manual, 3. Tire pressure check (1 BAR / 14.5 PSI), 4. Bolt/nut tightness, 5. Hose leak check, 6. Hydraulic oil level, 7. Fuel level, 8. Engine oil level, 9. Seat switch operation (LT-F, STOP, LT), 10. Air filter element, 11. Cutting unit settings, 12. Engine-coolant level, 13. Radiator cleanliness, 14. Machine cleaning/inspection, 15. Wheel nut tightness (200Nm front, 100Nm rear), 16. 8H service interval, 17. 50H service interval. The right section is a table titled 'SPECIFICATIONS/CHANGE INTERVALS'.

SEE OPERATOR'S MANUAL FOR INITIAL CHANGES	FLUID TYPE	CAPACITY	CHANGE INTERVAL		FILTER PART NO.
			FLUID	FILTER	
ENGINE OIL	10W-30 121-6393	5.5 LITRES	500 HOURS	500 HOURS	125-7025
HYDRAULIC FLUID	ISO VG 46	32 LITRES	1000 HOURS	1000 HOURS	94-2621
PRIMARY AIR FILTER				500 HOURS SEE SERVICE INDICATOR	108-3812
SAFETY AIR FILTER				SEE OPERATOR'S MANUAL	108-3819
FUEL SYSTEM	> -7 ° C	NO. 2 DIESEL			
	< -7 ° C	NO. 1 DIESEL	60 LITRES	500 HOURS/ YEARLY	125-8752 125-2915
ENGINE COOLANT	50% WATER 50% ETHYL GLYCOL	9.5 LITRES	1500 HOURS		

decal134-7637

134-7637

1. 8 hour service interval
2. Read the *Operator's Manual*.
3. Check the tire pressure.
4. Check all bolts and nuts for proper tightness.
5. Check all hoses for leaks.
6. Check the hydraulic-oil level.
7. Check the fuel level.
8. Check the engine-oil level.
9. Check the operation of the seat switch.
10. Check the air filter element.
11. Check the cutting unit settings.
12. Check the engine-coolant level.
13. Check the cleanliness of the radiator.
14. Clean and inspect the machine.
15. Check the wheel nut tightness using a torque wrench, front wheels 200 N•m, rear wheels 100 N•m.
16. 8 hour service interval
17. 50 hour service interval

Setup

Media and Additional Parts

Description	Qty.	Use
Operator's Manual	1	Read the manuals before operating the machine.
Engine owner's manual	1	
CE certificate	1	The certificate indicates CE compliance.

Store all documentation in a safe place for future use.

Note: Determine the left and right sides of the machine from the normal operating position.

Product Overview

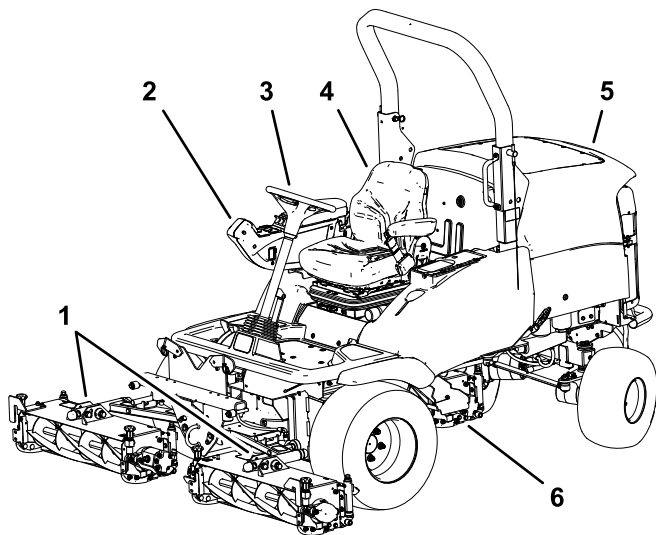

Figure 3

- | | |
|------------------------|----------------------|
| 1. Front cutting units | 4. Operator's seat |
| 2. Control arm | 5. Engine hood |
| 3. Steering wheel | 6. Rear cutting unit |

g318666

Controls

Control Panel Components

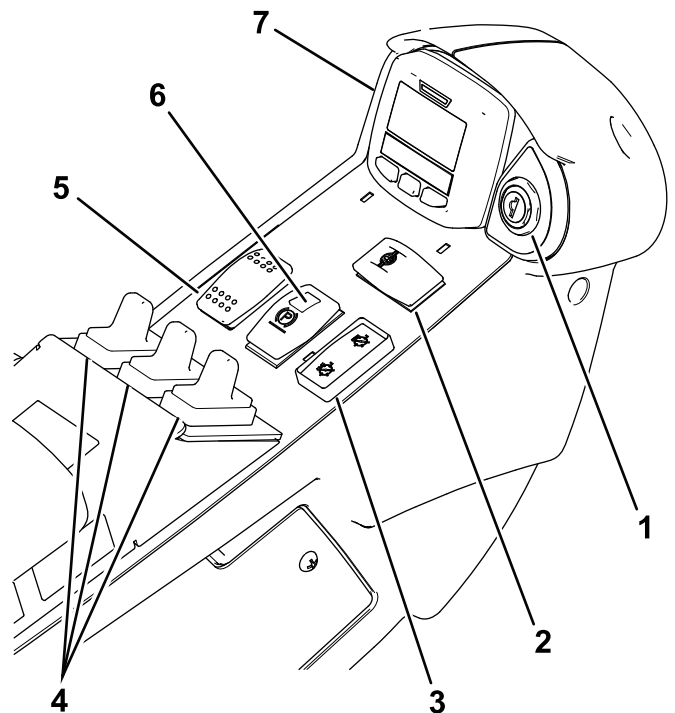

Figure 4

- | | |
|--|-------------------------|
| 1. Key switch | 5. Engine-speed switch |
| 2. Differential-lock switch (optional kit) | 6. Parking-brake switch |
| 3. Cutting-unit-drive switch | 7. InfoCenter |
| 4. Lift-control switches | |

g292362

Key Switch

Use the key switch to control the engine and power to certain electrical components.

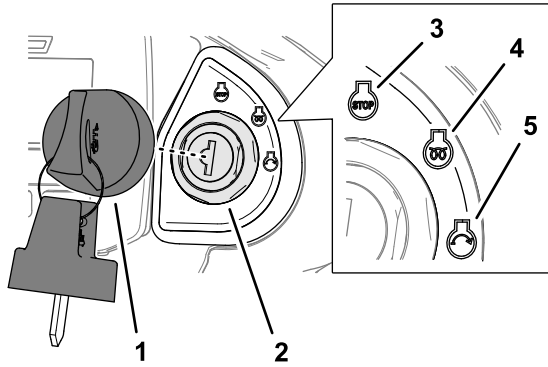

Figure 5

g290335

1. Key
2. Key switch
3. Shutoff position (stop)
4. Intake heater/run position
5. Start position

Cutting-Unit-Drive Switch

Use the cutting unit drive to run or shut off the cutting units (Figure 4).

Note: Always put the cutting-unit-drive switch in the OFF position when driving the machine between job sites.

Lift-Control Switches

Use the lift-control switches to raise and lower the cutting units (Figure 4).

Engine-Speed Switch

Use the engine-speed switch to control the speed of the engine.

The engine-speed switch (Figure 4) has 2 modes to change the engine speed.

Momentarily tap the switch to change the engine speed by 100 rpm increments.

Press and hold the switch forward to change the engine to HIGH-IDLE.

Press and hold the switch rearward to change the engine to LOW-IDLE.

Parking-Brake Switch

⚠ WARNING

The parking brake affects the front wheels only, and may not keep the machine from rolling down a slope. The machine could move unintentionally.

Do not park the machine on a slope.

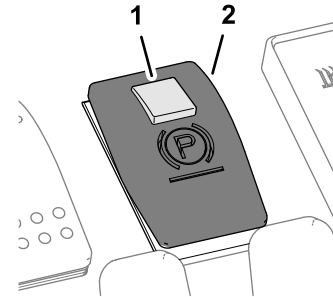

Figure 6

g289697

1. Locking button
2. Parking-brake switch

- To engage the parking brake, slide the small locking button on the top of the switch back and press the switch forward (Figure 6).

Note: The parking brake icon displays in the InfoCenter.

- To disengage the parking brake, press the switch back.

Service Brake

The hydraulic transmission provides the machine with service-brake effect. When you release the forward or reverse travel pedals or reduce engine speed, the transmission produces service-brake effect and ground speed slows or stops the machine. To increase the transmission-braking effect, push the transmission pedal into the NEUTRAL position. Only the front wheels provide service brake effect.

⚠ DANGER

The service braking system does not keep the machine from rolling when parked. The machine could move unintentionally.

Engage the parking brake when you park the machine.

Emergency Brake

If the service brake is damaged or ineffective, shut off the engine, engage the parking brake remove the key, and have the machine repaired.

Traction Pedals

Forward travel: Press the forward traction pedal to drive the machine forward and increase ground speed. Release the pedal to reduce ground speed (Figure 7).

Reverse travel: Press the reverse traction pedal to drive the machine backward and increase ground speed. Release the pedal to reduce ground speed (Figure 7).

Stop (Neutral): To stop the machine, use 1 of the following procedures:

- Reduce your foot pressure on the traction pedal and allow it to return to the neutral position. The machine dynamically brakes to a smooth stop.
- Tap or hold the reverse pedal briefly. This stops the machine faster than dynamic braking.

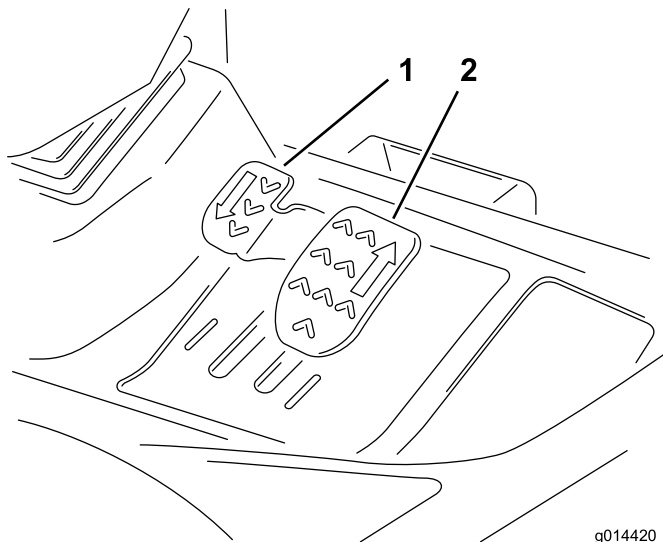

Figure 7

g014420
g014420

1. Reverse traction pedal
2. Forward traction pedal

Adjustable Steering Column

Adjust the steering wheel and column only when the machine is parked on level ground.

1. To tilt the steering wheel, press the foot pedal down.
2. Position the steering tower to the most comfortable position and release the pedal (Figure 8).



G014549

Figure 8

g014549

Operator's Seat Controls

Forward/Backward Adjustment

Move the lever upward to adjust the forward/backward position of the seat. Release the lever to lock the seat in position (Figure 9).

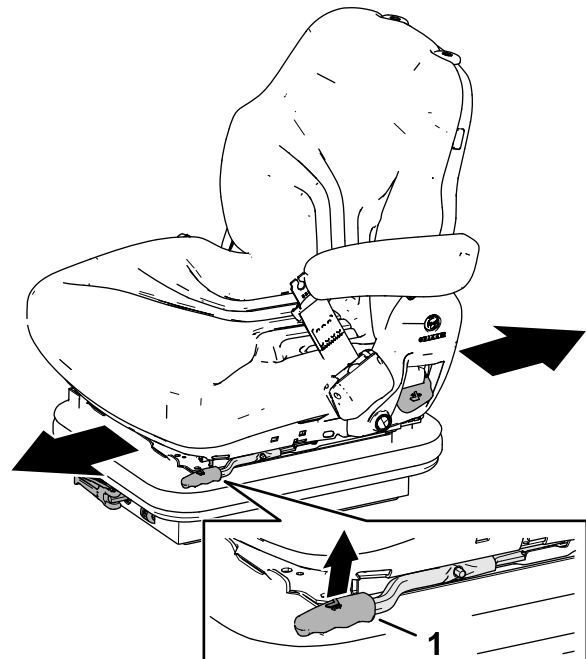

Figure 9

g327323

1. Lever

Operator Weight Adjustment

Rotate the handle clockwise to increase suspension stiffness and counterclockwise to decrease the stiffness. The dial indicates when the seat suspension is adjusted for the operator's weight (kg); refer to [Figure 10](#).



Figure 10

g327325

1. Lever

2. Dial

Height Adjustment

To adjust seat height incremental, manually lift the seat. To lower the seat, lift it beyond the highest setting, allow it to drop to the lowest setting, and if needed manually lift the seat to the desired height ([Figure 11](#)).

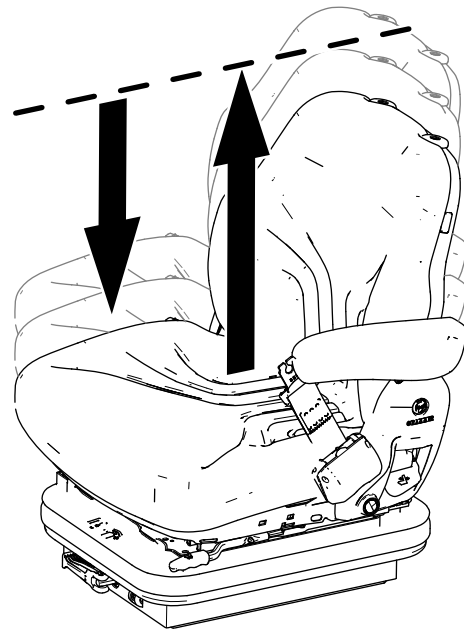

Figure 11

g327324

1. Handle

Backrest Adjustment

Pull the handle outward to adjust the seat backrest angle. Release the handle to lock the seat backrest in position ([Figure 12](#)).

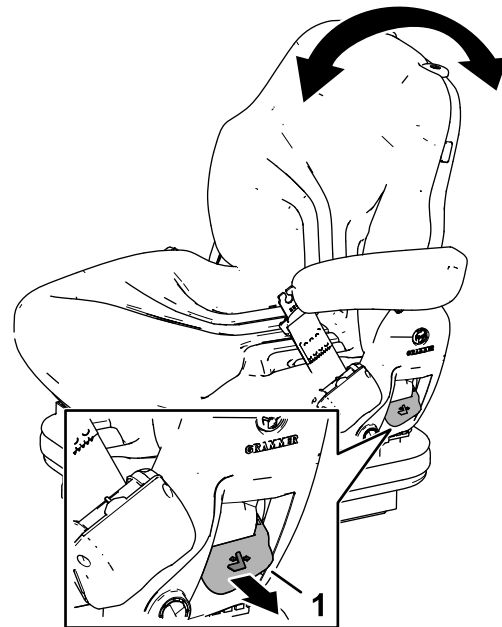

Figure 12

g327326

1. Handle

Fuel Gauge

The fuel gauge shows the amount of fuel in the tank (Figure 13).

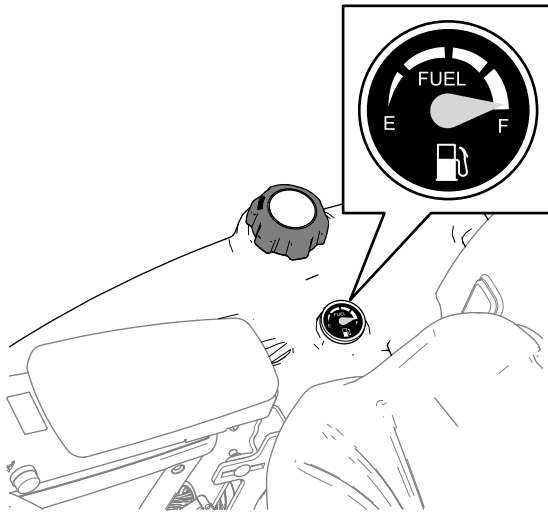

Figure 13

g295232

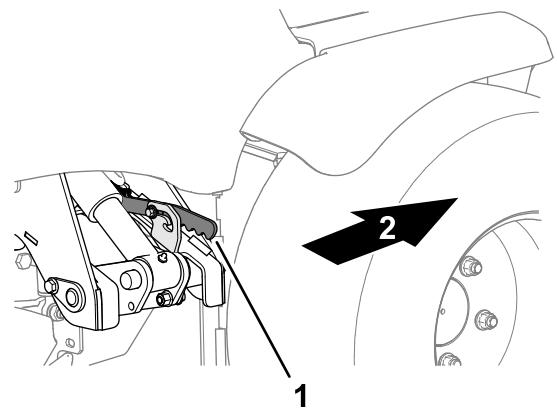

Figure 15

g327359

1. Latch arm (rear cutting-unit)
2. Front of the machine arm latch)

Transport Latches

Front Cutting Unit Arm Latches

Raise the cutting units to the TRANSPORT position and secure the arm-latch pins to the latches with the bails (Figure 14).

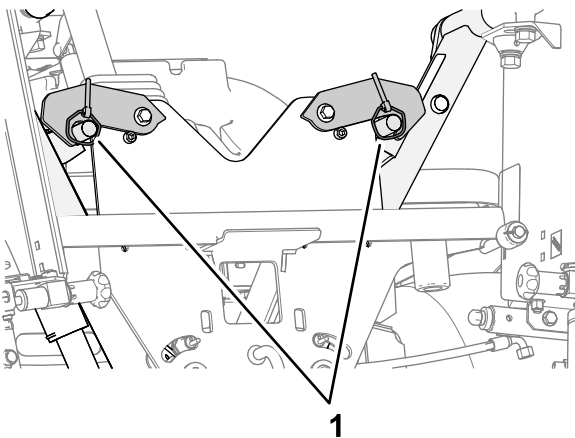

Figure 14

g327358

1. Bails (front cutting-unit arm latches)

Rear Cutting Unit Arm Latch

Raise the cutting units to the TRANSPORT position, lift the latch arm for the rear cutting-unit arm, and position the arm inboard (Figure 15).

Using the InfoCenter LCD Display

The InfoCenter LCD display shows information about your machine, such as the operating status, various diagnostics, and other information about the machine (Figure 16). There is a splash screen and main information screen of the InfoCenter. You can switch between the splash screen and main information screen at any time by pressing any of the InfoCenter buttons and then selecting the appropriate directional arrow.

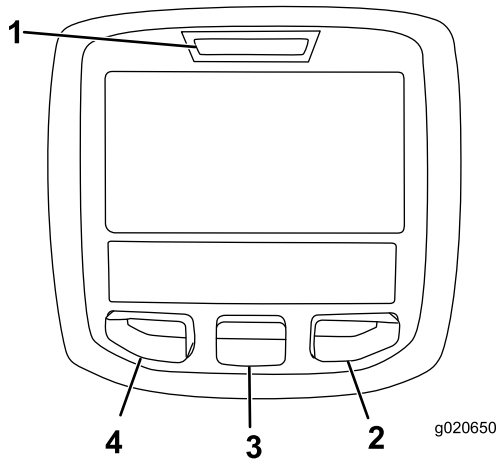

Figure 16

- | | |
|--------------------|------------------|
| 1. Indicator light | 3. Middle button |
| 2. Right button | 4. Left button |

- Left Button, Menu Access/Back Button—press this button to access the InfoCenter menus. You can use it to exit any menu that you are currently using.
- Middle Button—use this button to scroll down menus. You can also use it to quickly access the settings menu from the main information screen.
- Right Button—use this button to open a menu where a right arrow indicates additional content.

Note: The purpose of each button may change depending on what is required at the time. Each button is labeled with an icon displaying its current function.

InfoCenter Icon Descriptions

SERVICE DUE	Indicates when scheduled service should be performed
	Hours remaining until service
	Reset the service hours.
	The status of the engine speed (rpm)—InfoCenter display in languages other than English
RPM	The status of the engine speed (rpm)—InfoCenter display in English
	Info icon
	Stationary regeneration is required.
	The air-intake heater is active.
	The operator must sit in the seat.
	The parking brake is engaged.
N	Neutral
	Coolant temperature (°C or °F)
	Temperature (hot)
	Not allowed
	Start the engine.
	The PTO is on.
	Shut off the engine.
	Engine
	Key switch
	Cutting units are lowering
	Cutting units are raising
CAN	CAN bus
	InfoCenter
Bad	Bad or failed
Ctr	Center

InfoCenter Icon Descriptions (cont'd.)

	Right
	Left
	Bulb
	Output of TEC controller or control wire in harness
	Switch
	Operator must release switch
	Operator should change to indicated state
Symbols are often combined to form sentences. Some examples are shown below.	
	Operator should put machine in neutral
	Engine start is denied
	Engine shutdown
	Engine coolant is too hot
	DPF ash accumulation notification. Refer to Servicing the Diesel Particulate Filter (DPF) in the maintenance section for details
	Reset-standby regeneration request
	Parked or recovery regeneration request
	A parked or recovery regeneration is processing.
	High exhaust temperature
	NOx control diagnosis malfunction; drive the machine back to the shop and contact your authorized Toro distributor (software version U and later).
	The power take-off is disabled.

InfoCenter Icon Descriptions (cont'd.)

	Sit down or engage the parking brake.
	Indicates that limited lift reverse is active.

Accessible only by entering PIN

Using the Menus

To access the InfoCenter menu system, press the menu access button while at the main screen. This displays the main menu. Refer to the following tables for a synopsis of the options available from the menus:

Main Menu

Menu Item	Description
Faults	Contains a list of the recent machine faults. Refer to the <i>Service Manual</i> or your authorized Toro distributor for more information on the Faults menu and the information contained there.
Diagnostics	Lists various states that the machine currently has; you can use this to troubleshoot certain issues as it quickly tells you which machine controls are on and which are off.
Service	Contains information on the machine such as hours of use, counters, and other similar numbers.
Settings	Allows you to customize and modify configuration variables on the InfoCenter display.
About	Lists the model number, serial number, and software version of your machine.



Service

Menu Item	Description
Hours	Lists the total number of hours that the machine, engine, and PTO have been on, as well as the number of hours the machine has been transported and service due
Counts	Lists numerous counts the machine experienced
DPF Regeneration	The diesel particulate filter regeneration option and DPF submenus

Service (cont'd.)

Menu Item	Description
Backlap	Use to turn backlap on or off
Inhibit Regen	Use to control reset regeneration
Parked Regen	Use to initiate a parked regeneration
Last Regen	Lists the number hours since the last reset, parked, or recovery regeneration
Recover Regen	Use to initiate a recovery regeneration

Settings

Menu Item	Description
Units	Controls the units used on the InfoCenter (English or Metric)
Language	Controls the language used on the InfoCenter*
LCD Backlight	Controls the brightness of the LCD display
LCD Contrast	Controls the contrast of the LCD display
Protected Menu 	Allows an authorized person with the PIN code to access protected menus
Protect Settings 	Allows the ability to change the settings in the protected settings
Limited Lift Reverse	Turns limited lift on or off when in reverse. Applies to all heads.
Slope Sensor Installed 	Indicates a slope sensor is detected in the machine.
Turnaround	Turns turnaround mode on or off. One touch lift/lower limited lift. Applies to all heads.

 Accessible only by entering PIN

About

Menu Item	Description
Model	Lists the model number of the machine
SN	Lists the serial number of the machine
Machine Controller Revision	Lists the software revision of the master controller
InfoCenter Revision 	Lists the software revision of the InfoCenter

About (cont'd.)

Menu Item	Description
CAN Bus 	Lists the machine communication bus status

 Accessible only by entering PIN

Diagnostics

Menu Item	Description
Engine Run	Refer to the Service Manual or your authorized Toro distributor for more information on the Engine Run menu and the information contained there.
Decks Raise	
Decks Lower	
PTO	
Traction	

Protected Menus

There are operating configuration settings that are adjustable within the Settings Menu of the InfoCenter. To lock these settings, use the Protected Menu.

Note: At the time of delivery, the initial password code is programmed by your authorized Toro distributor.

Accessing Protected Menus

Note: The factory default PIN code for your machine is either 0000 or 1234.

If you changed the PIN code and forgot the code, contact your authorized Toro distributor for assistance.

1. From the MAIN MENU, use the center button to scroll down to the SETTINGS MENU and press the right button (Figure 17).

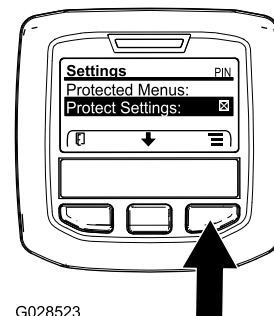

G028523

g028523

Figure 17

2. In the SETTINGS MENU, use the center button to scroll down to the PROTECTED MENU and press the right button (Figure 18A).

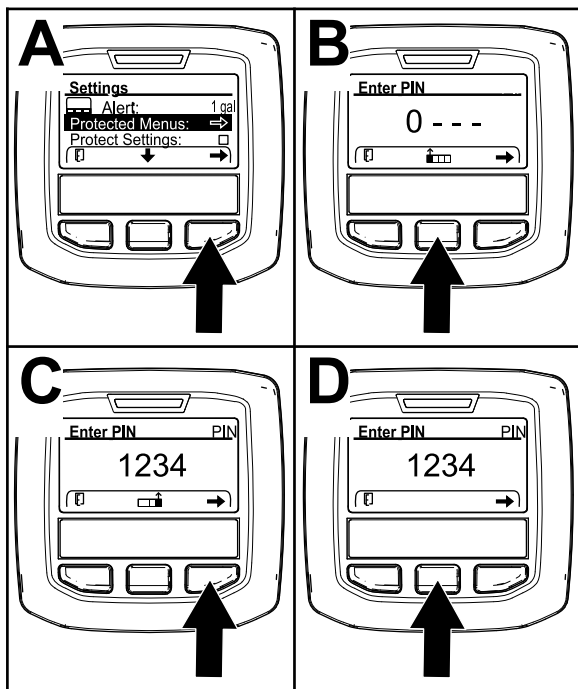

Figure 18

g338379

Viewing and Changing the Protected Menu Settings

In the Protected Menu, scroll down to Protect Settings and perform 1 of the following:

- To view and change the settings without entering a PIN code, and use the right button to change the Protect Settings to OFF.
- To view and change the settings with a PIN code, use the left button to change the Protect Settings to ON, set the PIN code, and turn the key in the ignition switch to the OFF position and then to the ON position.

3. To enter the PIN code, press the center button until the correct first digit appears, then press the right button to move on to the next digit (Figure 18B and Figure 18C). Repeat this step until the last digit is entered and press the right button once more.
4. Press the middle button to enter the PIN code (Figure 18D).

Wait until the red indicator light of the InfoCenter illuminates.

Note: If the InfoCenter accepts the PIN code and the protected menu is unlocked, the word “PIN” displays in the upper right corner of the screen.

Note: Rotate the key switch to the OFF position and then to the ON position locks the protected menu.

You can view and change the settings in the Protected Menu. Once you access the Protected Menu, scroll down to Protect Settings option. Use the right button to change the setting. Setting the Protect Settings to OFF allows you to view and change the settings in the Protected Menu without entering the PIN code. Setting the Protect Settings to ON hides the protected options and requires you to enter the PIN code to change the setting in the Protected Menu. After you set the PIN code, rotate the key switch OFF and back to the ON position to enable and save this feature.

Specifications

Specification	LT3340
Transport Width	157.5 cm (62 inches)
Width of cut	76 cm (30 inches) to 212 cm (83.5 inches)
Height of cut	13 mm (1/2 inch) to 76 mm (3 inches)
Length (including front cutting units)	289 cm (114 inches)
Height	168 cm (66.2 inches) with ROPS down
	216 cm (85.0 inches) with ROPS up
	209 cm (82.3 inches) with cab
Weight (with 250 mm, 6-blade cutting units; without fuel or accessories)	1427 kg (3,146 lb) with ROPS
	1627 kg (3,587 lb) with cab
Engine	Yanmar 3TNV88C; 27.5 kw (37 hp) at 3,000 rpm
Fuel tank capacity	60 L (15.9 US gallons)
Transport speed	25 km/h (15.5 mph)
Mowing speed	11 km/h (6.85 mph)
Hydraulic system capacity	32 L (8.5 US gallons)
Engine speed	3000 rpm
Reel speed	1000 rpm

Note: Specifications and design are subject to change without notice.

Attachments/Accessories

A selection of Toro approved attachments and accessories is available for use with the machine to enhance and expand its capabilities. Contact your Authorized Service Dealer or authorized Toro distributor or go to www.toro.com/en-gb for a list of all approved attachments and accessories.

To ensure optimum performance and continued safety certification of the machine, use only genuine Toro replacement parts and accessories. Replacement parts and accessories made by other manufacturers could be dangerous, and such use could void the product warranty.

Operation

Before Operation

Before Operation Safety

General Safety

- Never allow children or untrained people to operate or service the machine. Local regulations may restrict the age of the operator. The owner is responsible for training all operators and mechanics.
- Become familiar with the safe operation of the equipment, operator controls, and safety signs.
- Before you leave the operator's position, do the following:
 - Park the machine on a level surface.
 - Disengage and lower the cutting units.
 - Engage the parking brake.
 - Shut off the engine and remove the key.
 - Wait for all movement to stop.
 - Allow the machine to cool before adjusting, servicing, cleaning, or storing it.
- Know how to stop the machine and shut off the engine quickly.
- Do not operate the machine without all guards and other safety protective devices in place and functioning properly on the machine.
- Before mowing, always inspect the machine to ensure that the cutting units are in good working condition.
- Inspect the area where you will use the machine and remove all objects that the machine could throw.
- This product generates an electromagnetic field. If you wear an implantable electronic medical device, consult your health care professional before using this product.

Fuel Safety

- Use extreme care in handling fuel. It is flammable and its vapors are explosive.
- Extinguish all cigarettes, cigars, pipes, and other sources of ignition.
- Use only an approved fuel container.
- Do not remove the fuel cap or fill the fuel tank while the engine is running or hot.
- Do not add or drain fuel in an enclosed space.

- Do not store the machine or fuel container where there is an open flame, spark, or pilot light, such as on a water heater or other appliance.
- If you spill fuel, do not attempt to start the engine; avoid creating any source of ignition until the fuel vapors have dissipated.

Performing Daily Maintenance

Before starting the machine each day, perform the Each Use/Daily procedures listed in [Maintenance \(page 34\)](#).

Filling the Fuel Tank

Fuel Tank Capacity

60 L (15.9 US gallons)

Fuel Specification

Important: Use only ultra-low sulphur diesel fuel. Fuel with higher rates of sulfur degrades the diesel oxidation catalyst (DOC), which causes operational problems and shortens the service life of engine components.

Failure to observe the following cautions may damage the engine.

- Never use kerosene or gasoline instead of diesel fuel.
- Never mix kerosene or used engine oil with the diesel fuel.
- Never keep fuel in containers with zinc plating on the inside.
- Do not use fuel additives.

Petroleum Diesel

Cetane rating: 45 or higher

Sulfur content: Ultra-low sulfur (<15 ppm)

Fuel Table

Diesel fuel specification	Location
ASTM D975 No. 1-D S15 No. 2-D S15	USA
EN 590	European Union
ISO 8217 DMX	International
JIS K2204 Grade No. 2	Japan
KSM-2610	Korea

- Use only clean, fresh diesel fuel or biodiesel fuels.
- Purchase fuel in quantities that can be used within 180 days to ensure fuel freshness.

Use summer-grade diesel fuel (No. 2-D) at temperatures above -7°C (20°F) and winter-grade fuel (No. 1-D or No. 1-D/2-D blend) below that temperature.

Note: Use of winter-grade fuel at lower temperatures provides lower flash point and cold flow characteristics which eases starting and reduces fuel filter plugging. Using summer-grade fuel above -7°C (20°F) contributes toward longer fuel pump life and increased power compared to winter-grade fuel.

Biodiesel

This machine can also use a biodiesel blended fuel of up to B20 (20% biodiesel, 80% petroleum diesel).

Sulfur content: Ultra-low sulfur (<15 ppm)

Biodiesel fuel specification: ASTM D6751 or EN14214

Blended fuel specification: ASTM D975, EN590, or JIS K2204

Important: The petroleum diesel portion must be ultra-low sulfur.

Observe the following precautions:

- Biodiesel blends may damage painted surfaces.
- Use B5 (biodiesel content of 5%) or lesser blends in cold weather.
- Monitor seals, hoses, gaskets in contact with fuel as they may be degraded over time.
- Fuel filter plugging may be expected for a time after converting to biodiesel blends.
- Contact your authorized Toro distributor for more information on biodiesel.

Adding Fuel

1. Park the machine on a level surface, lower the cutting units, shut off the engine, engage the parking brake, and remove the key.

- Using a clean rag, clean area around fuel-tank cap.
- Remove the cap from the fuel tank (Figure 19).

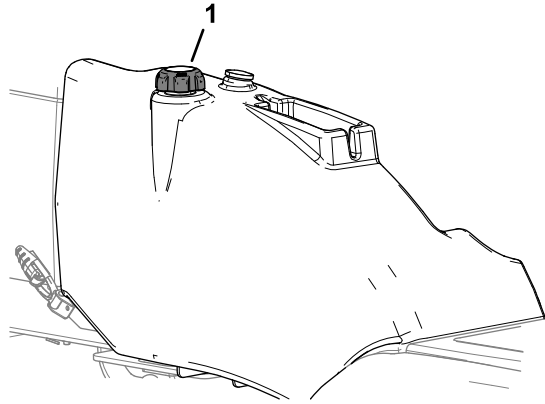

Figure 19

g290356

- Fuel-tank cap

- Fill the tank until the level is 25 mm (1 inch) below the bottom of the filler neck.
- Install the fuel-tank cap tightly after filling the tank.

Note: If possible, fill the fuel tank after each use. This minimizes possible buildup of condensation inside the fuel tank.

Checking the Forward/Reverse Traction Pedal Action

Service Interval: Before each use or daily

With the engine shut off, operate the forward and reverse traction pedals through the full range of articulation and ensure that the mechanism returns freely to the NEUTRAL position.

Checking the Interlock Switches







Service Interval: Before each use or daily operator presence, cutting-unit drive interlock, parking brake interlock, and transmission neutral interlock.

Checking the Operator Presence Seat Switch



- Sit on the operator's seat and start the engine.
- Lower the cutting units to the ground.

- Set the cutting-unit-drive switch to the forward-cut position.
- Rise from the operator's seat and check that the cutting units stop after an initial 0.5 to 1 second delay.
- Repeat steps 1 through 4 with the cutting-unit-drive switch in the reverse position.

Checking the Cutting-Unit Drive Interlock Switch



- Shut off the engine.
- Set the cutting-unit-drive switch to the OFF position and turn the ignition key to preheat-run position . The PTO icon  should not display in the InfoCenter.
- Set the cutting-unit-drive switch to the forward-cut position. The PTO icon  displays, but the engine should not start when you rotate the ignition key to the START position .
- Set the cutting-unit-drive switch to the reverse position. The PTO icon  displays, but the engine should not start when you rotate the ignition key to the START position .

Checking the Parking Brake Interlock Switch

- Shut off the engine.
- Engage the parking brake.
- Rotate the ignition key to the preheat-run position . The parking-brake switch illuminates and the parking brake icon  displays in the InfoCenter.
- Disengage the parking brake; the parking brake light and icon shut off. The engine should not start when you rotate the ignition key to the START position .
- Engage the parking brake, sit on the operator's seat, and start the engine.
- Disengage the parking brake.
- Rise from the operator seat's and check that the engine shuts off.

Checking the Transmission Neutral Interlock Switch

Important: Take extreme care to ensure that the area around the machine is clear before checking that the engine does not start when checking the neutral interlock switch.

1. Shut off the engine.
2. Remove your foot from the forward/reverse travel pedals.
3. Turn the ignition key to preheat-run position .
The transmission neutral icon  displays in the InfoCenter.
4. Apply light pressure to the travel pedals in a forward and reverse direction to check that the transmission neutral icon is not displayed in the InfoCenter.

During Operation

During Operation Safety

General Safety

- The owner/operator can prevent and is responsible for accidents that may cause personal injury or property damage.
- Wear appropriate clothing, including eye protection; long trousers; substantial, slip-resistant footwear; and hearing protection. Tie back long hair and do not wear loose clothing or loose jewelry.
- Do not operate the machine while ill, tired, or under the influence of alcohol or drugs.
- Use your full attention while operating the machine. Do not engage in any activity that causes distractions; otherwise, injury or property damage may occur.
- Before you start the engine, ensure that all drives are in neutral, the parking brake is engaged, and you are in the operating position.
- Do not carry passengers on the machine and keep bystanders and children out of the operating area.
- Operate the machine only in good visibility to avoid holes or hidden hazards.
- Avoid mowing on wet grass. Reduced traction could cause the machine to slide.
- Keep your hands and feet away from the cutting units.
- Look behind and down before backing up to be sure of a clear path.

- Use care when approaching blind corners, shrubs, trees, or other objects that may obscure your vision.
- Stop the cutting units whenever you are not mowing.
- Slow down and use caution when making turns and crossing roads and sidewalks with the machine. Always yield the right-of-way.
- Operate the engine only in well-ventilated areas. Exhaust gases contain carbon monoxide, which is lethal if inhaled.
- Do not leave a running machine unattended.
- Before you leave the operator's position, do the following:
 - Park the machine on a level surface.
 - Disengage and lower the cutting units.
 - Engage the parking brake.
 - Shut off the engine and remove the key.
 - Wait for all movement to stop.
 - Allow the machine to cool before adjusting, servicing, cleaning, or storing it.
- Operate the machine only in good visibility and appropriate weather conditions. Do not operate the machine when there is the risk of lightning.
- Use the cruise control (if equipped) only when you can operate the machine in an open, flat area that is free from obstacles and where the machine can move at a constant speed without interruption.

Rollover Protection System (ROPS) Safety

- Do not remove any of the ROPS components from the machine.
- Ensure that the seat belt is attached and that you can release it quickly in an emergency.
- Always wear your seat belt.
- Check carefully for overhead obstructions and do not contact them.
- Keep the ROPS in safe operating condition by thoroughly inspecting it periodically for damage and keeping all the mounting fasteners tight.
- Replace all damaged ROPS components. Do not repair or alter them.

Machines with a Foldable Roll Bar

- Always use the seat belt with the roll bar in the raised position.
- The ROPS is an integral safety device. Keep a folding roll bar in the raised and locked position,

and use the seat belt when operating the machine with the roll bar in the raised position.

- Lower a folding roll bar temporarily only when necessary. Do not wear the seat belt when the roll bar is folded down.
- Be aware that there is no rollover protection when a folded roll bar is in the down position.
- Check the area that you will be mowing and never fold down a folding roll bar in areas where there are slopes, drop-offs, or water.

Slope Safety

- Slopes are a major factor related to loss of control and rollover accidents, which can result in severe injury or death. You are responsible for safe slope operation. Operating the machine on any slope requires extra caution.
- Evaluate the site conditions to determine if the slope is safe for machine operation, including surveying the site. Always use common sense and good judgment when performing this survey.
- Review the slope instructions, listed below, for operating the machine on slopes. Before you operate the machine, review the site conditions to determine whether you can operate the machine in the conditions on that day and at that site. Changes in the terrain can result in a change in slope operation for the machine.
 - Avoid starting, stopping, or turning the machine on slopes. Avoid making sudden changes in speed or direction. Make turns slowly and gradually.
 - Do not operate a machine under any conditions where traction, steering, or stability is in question.
 - Remove or mark obstructions such as ditches, holes, ruts, bumps, rocks, or other hidden hazards. Tall grass can hide obstructions. Uneven terrain could overturn the machine.
 - Be aware that operating the machine on wet grass, across slopes, or downhill may cause the machine to lose traction.
 - Use extreme caution when operating the machine near drop-offs, ditches, embankments, water hazards, or other hazards. The machine could suddenly roll over if a wheel goes over the edge or the edge caves in. Establish a safety area between the machine and any hazard.
 - Identify hazards at the base of the slope. If there are hazards, mow the slope with a pedestrian-controlled machine.
 - If possible, keep the cutting units lowered to the ground while operating on slopes. Raising

the cutting units while operating on slopes can cause the machine to become unstable.

Understanding the Operator Presence Controls

⚠ CAUTION

If safety interlock switches are disconnected or damaged the machine could operate unexpectedly causing, personal injury.

- Do not tamper with the interlock switches.
- Check the operation of the interlock switches daily and replace any damaged switches before operating the machine.

Important: Do not operate the machine if the operator presence controls are damaged or worn. Always replace damaged or worn parts, and check that operator presence controls function correctly before operating the machine.

Engine Start Interlock

You can start the engine only when the forward/reverse travel pedal is in the NEUTRAL position, the cutting-unit-drive switch is in the OFF position, and the parking brake is engaged.

Note: You can start the engine only when the cutting-unit-drive switch is in the OFF position.

Engine Run Interlock

Once you start the engine, you must sit in the operator's seat to run the engine while the parking brake is disengaged.

The engine shuts off if you leave the operator's seat without first engaging the parking brake.

Cutting Unit Drive Interlock

You must sit in the operator's seat to run the cutting units. If you raise off the seat for more than a second, a switch activates and the drive to the cutting units disengages.

To reset the cutting units, sit in the seat, move the cutting-unit-drive switch to the OFF position, and then move the switch to the ON position.

Note: If you briefly raise off the seat during normal work, drive to the cutting units is not affected.

Adjusting the Roll Bar

⚠ WARNING

To avoid injury or death from rollover, keep the roll bar in the raised locked position and use the seat belt.

Ensure that the seat is secured with the seat latch.

⚠ WARNING

There is no rollover protection when the roll bar is in the down position.

- Do not operate the machine on uneven ground or on a hill side with the roll bar in the down position.
- Lower the roll bar only when absolutely necessary.
- Do not wear the seat belt when the roll bar is in the down position.
- Drive slowly and carefully.
- Raise the roll bar as soon as clearance permits.
- Check carefully for overhead clearances (i.e., branches, doorways, electrical wires) before driving under any objects and do not contact them.

Important: Always use the seat belt when the roll bar is in the raised and locked position. Do not use the seat belt when the roll bar is in the lowered position.

Lowering the Roll Bar

1. Park the machine on a level surface, lower the cutting units, engage the parking brake, shut off the engine, and remove the key.
2. Remove the hairpins from the roll-bar pins in the pivot brackets of the lower roll-bar frame (Figure 20).

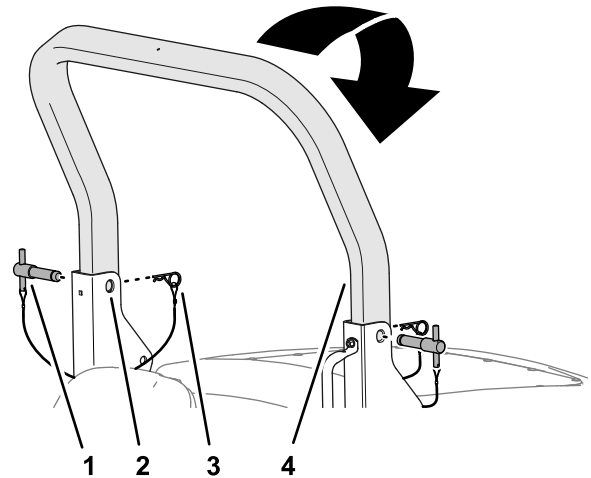

Figure 20

g290634

1. Roll-bar pin
2. Pivot bracket upper (lower roll-bar frame)
3. Hairpin
4. Upper roll bar

3. While supporting the weight of the upper roll bar, remove the roll-bar pins from the pivot brackets (Figure 20).
4. Carefully lower the upper roll bar until it rests on the stops of the lower roll-bar frame.
5. Insert the roll-bar pins in the lower holes of the pivot brackets (Figure 21).

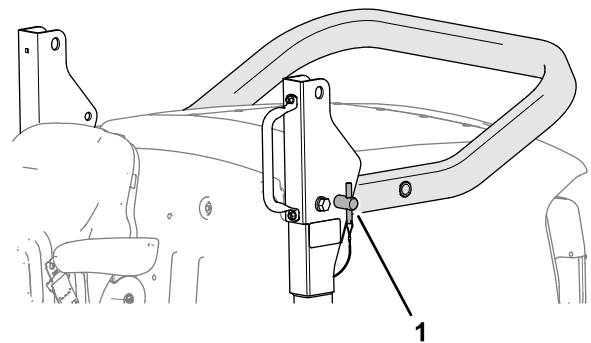

Figure 21

g290636

1. Roll-bar pin (lower position)

6. Secure roll-bar pins to the pivot brackets with the hairpins.

Raising the Roll Bar

1. Remove the hairpins that secure the roll-bar pins to the pivot brackets of the lower roll-bar frame.
2. Remove the roll-bar pins to the pivot brackets (Figure 22).

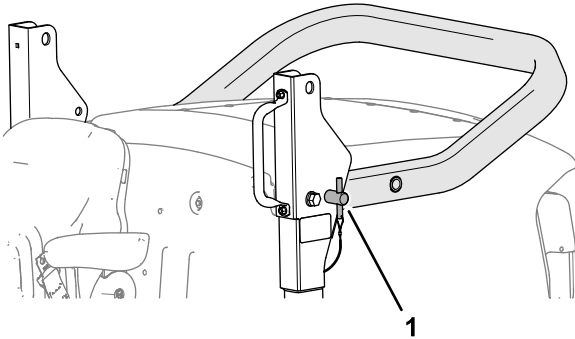

Figure 22

g290636

1. Roll-bar pin

3. Raise the upper roll bar until the holes in the roll bar align with the pivot brackets (Figure 23).

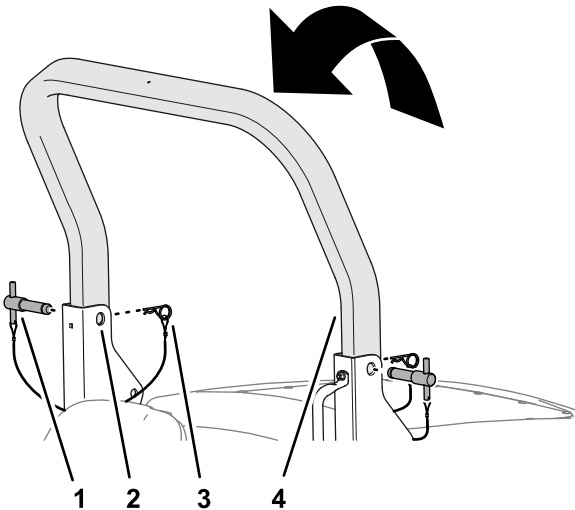

Figure 23

g290635

1. Roll-bar pin
2. Pivot bracket upper hole (lower roll-bar frame)
3. Hairpin
4. Upper roll bar

4. Insert the roll-bar pins through the upper holes of the pivot brackets and the upper roll bar (Figure 23).
5. Secure roll-bar pins to the pivot brackets with the hairpins (Figure 23).

Starting the Engine

Important: If you are starting the engine for the first time, the engine has stopped from lack of fuel, or you performed fuel system maintenance, bleed the fuel system before starting the engine; refer to [Priming the Fuel System \(page 45\)](#).

Important: This machine is fitted with an engine start lockout; refer to [Understanding the Operator Presence Controls \(page 23\)](#).

1. Engage the parking brake, move the traction pedal to the NEUTRAL position, and ensure that the cutting unit drive switch is in the OFF position.
2. Turn the key to the INTAKE HEATER/RUN POSITION position.

Note: The pre-heat indicator icon  displays in the InfoCenter. Wait until the pre-heat indicator icon no longer displays.

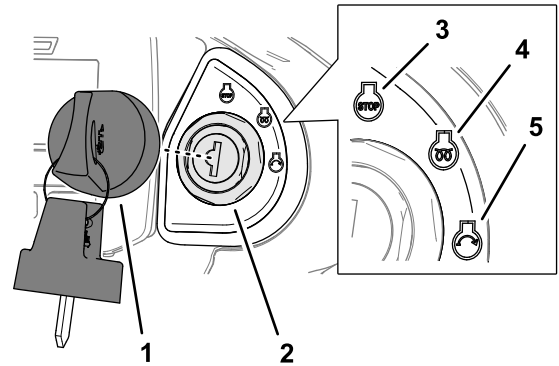

Figure 24

g290335

1. Key
2. Key switch
3. Shutoff position (stop)
4. Intake heater/run position
5. Start position

3. Rotate the key to the start position.

When the engine starts, release the key to the intake heater/run position.

Important: Crank the engine for no longer than 15 seconds.

4. Run the engine at low idle speed until it warms up.

Shutting Off the Engine

Important: Allow the engine to idle for 5 minutes before shutting it off after a full-load operation. This allows the turbocharger to cool down before shutting off the engine. Failure to idle the engine may damage the turbocharger.

1. Move the traction pedal to the NEUTRAL position, shut off the cutting unit drive switch, engage the parking brake, and lower the cutting units.

2. Press the engine speed switch until the engine speed is at low idle.
3. Let the engine run for at least 5 minutes.
4. Turn the key to shutoff (stop) position (Figure 25).

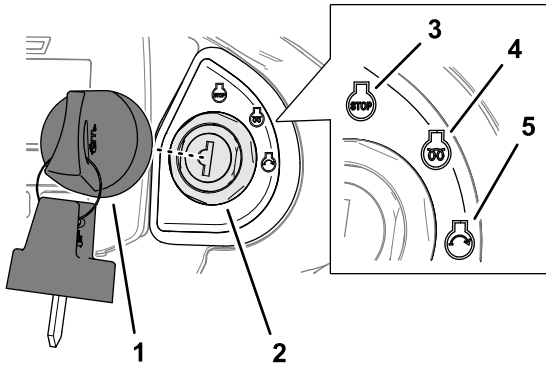

Figure 25

g290335

- | | |
|----------------------------|-------------------------------|
| 1. Key | 4. Intake heater/run position |
| 2. Key switch | 5. Start position |
| 3. Shutoff position (stop) | |

5. Remove the key before you leave the operator's seat.

Using the Cutting Units

Adjusting the Grass Deflectors

Adjust the rear grass deflectors as low as possible so that grass clippings discharge to the ground without restricting clippings exiting cutting unit (Figure 26).

Note: Always position the rear grass deflectors correctly.

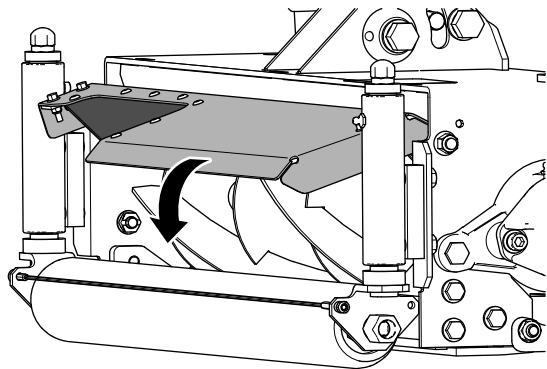

Figure 26

g327581

Adjusting the Center Cutting Unit Height-of-Cut Correction

With all cutting units set at the same HOC as shown by the indicator rings, you may notice that the center cutting unit produces a higher cut finish compared to that of the left and right cutting units. The machine pulls the center cutting unit whereas the left and right cutting units are pushed; this affects the cutting unit angle relative to the ground. The amount of HOC variation that results from this effect is also influenced by the terrain, but you can achieve satisfactory results by setting the center cutting unit HOC indicator ring lower than the left and right cutting unit settings.

Controlling the Position of the Individual Cutting Units

Use the 3 lift-control switches to raise or lower the cutting units independently.

Lowering the Cutting Unit

1. Press the cutting-unit-drive switch to the FORWARD ROTATION position.
2. Press the lift-control switch forward and release.

Note: The cutting unit engages when it is approximately 150 mm (6 inches) above ground level. The cutting unit is in 'float' mode, and follows the ground contours.

Note: The lift-control switch automatically returns to the (NEUTRAL) position when you release it.

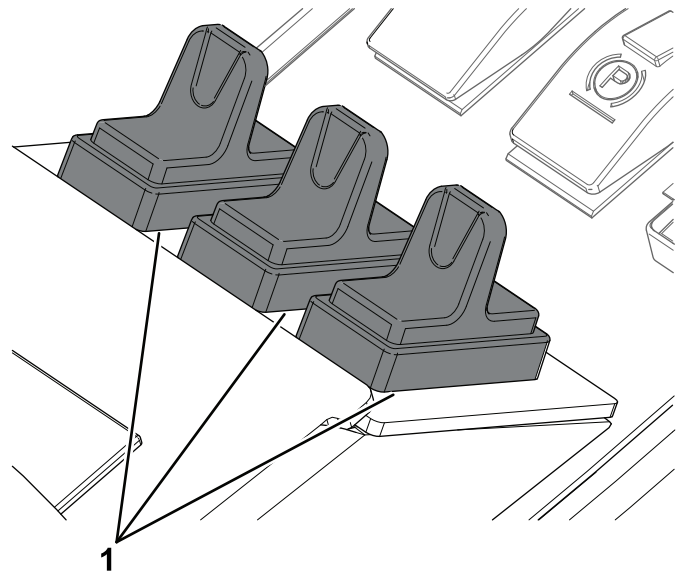

Figure 27

g287651

1. Lift-control switches

Raising the Cutting Unit

1. Pull and hold the lift-control switch.
2. Release the lift-control switches when the cutting units are at the needed height.

Note: The lift-control switches automatically return to the (NEUTRAL) position when you release it and the cutting unit arms hydraulically lock into position.

Cutting Unit Limited-Lift Position

Limiting Cutting Unit Lift When Driving Forward

Note: The limited lift function for driving forward is enabled by default.

- While driving forward, momentarily pull the lift-control switch(s).
Note: The cutting unit(s) shuts off and it raises approximately 150 mm (6 inches) above ground level.
- The limited lift function shuts off when the cutting unit is lowered and running.

Limiting Cutting Unit Lift When Driving Backward

Note: You must enable the limited-lift function in the InfoCenter to automatically lift the cutting units when driving backward.

- When the limited-lift function is enabled, driving the machine backward causes all cutting units raise to the limited-lift position.

Note: The cutting unit(s) raises approximately 150 mm (6 inches) above ground level.

Important: The cutting units continue to run while using limited lift and driving the machine backward.

- Driving the machine forward again causes the cutting unit lower to the float position.

Using the Cutting-Unit Turnaround Feature

Note: You must enable the turnaround feature for the center lift-control switch in the settings menu of the InfoCenter.

- Momentarily pull the lift-control switch for the center cutting unit to raise all cutting units to the limited lift position.
- Momentarily push down the lift-control switch for the center cutting unit to lower all cutting units to the float position.

Adjusting the Cutting Unit Auto-Limited Lift

Note: You enable the cutting-unit Auto Limited Lift feature in the settings menu of the InfoCenter.

- Manual limited lift uses the 3 lift-control switches, and is always available regardless of auto-limited lift setting in the InfoCenter.
- When cutting-unit Auto Limited Lift is enabled, driving the machine in reverse causes the cutting units to automatically raise to the limited-lift position.
- The cutting units return to the floating position when driving the machine forward.

To raise the cutting units to the limited-lift position, momentarily pull the lift-control switches.

Note: The cutting-unit drives disengage immediately, and the cutting units raise to approximately 150 mm (6 inches) above ground level.

Auto-limited lift operates with the cutting units lowered and rotating.

Cutting Unit Drive

The cutting unit drive engages only when you sit in the operator's seat; refer to [Checking the Operator Presence Seat Switch](#) (page 21).

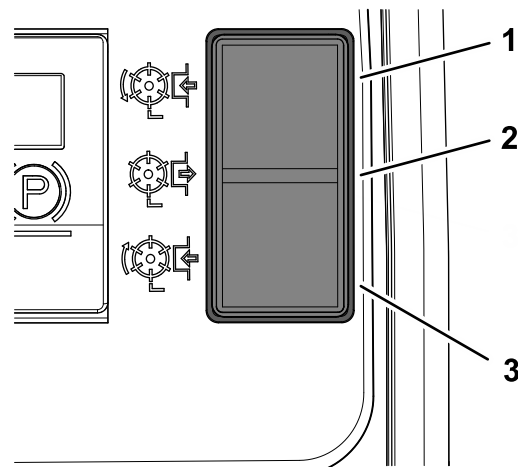

Figure 28

1. Forward
2. Off
3. Reverse

g292363

Engaging the Cutting Unit Drive for Forward Rotation

Press the top of the cutting unit drive switch to the forward rotation position (Figure 28).

Engaging the Cutting Unit Drive for Reverse Rotation

Press the bottom of the cutting unit drive switch to the reverse rotation position ([Figure 28](#)).

Disengaging All Cutting Unit Drives

Press the cutting unit drive switch to the middle position ([Figure 28](#)).

Lowering the Cutting Units

Press the cutting unit drive switch to the forward rotation position. Press the lift-control switch(s) to the LOWER position. The cutting units run when they are approximately 150 mm (6 inches) above ground level.

Adjusting the Weight Transfer/Traction Assistance

A variable hydraulic weight transfer system provides improved tire grip with the grass surface—traction assistance.

Hydraulic pressure from the cutting-unit lift system provides a lifting force that reduces the weight of the cutting units on the ground and transfers the weight downward to the tires. This action is known as weight transfer.

Note: Adjust the amount of weight transfer to suit operating conditions.

1. Open the hood.

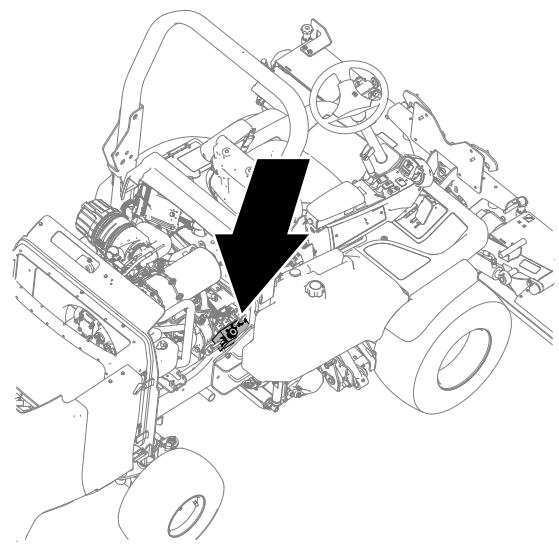

g292364

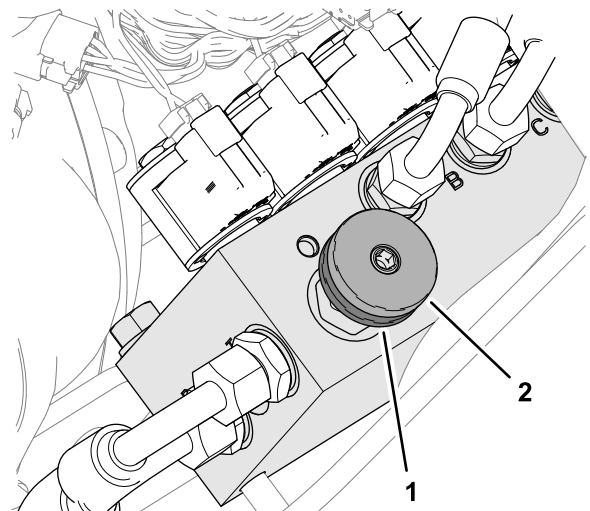

g292365

Figure 29

1. Lock wheel
2. Weight transfer hand wheel

2. At the right side of the machine, loosen the lock wheel of the weight transfer manifold 1/2 turn counterclockwise while holding the hand wheel steady ([Figure 29](#)).
3. Rotate the weight transfer hand wheel ([Figure 29](#)) as follows:
 - counterclockwise to reduce weight transfer
 - clockwise to increase weight transfer

Note: The recommended setting for the weight transfer/traction assistance is to increase the weight transfer until the cutting units start to lift, then rotate the hand wheel 1/2 turn counterclockwise.

4. Tighten the lock wheel ([Figure 29](#)).

Clearing the Cutting Units

▲ WARNING

Never attempt to rotate the cutting units by hand. Residual pressure in the hydraulic system could cause the cutting unit(s) to rotate suddenly when you release the blockage, which may cause serious injury.

- Always wear protective gloves and use a suitable strong wooden instrument.
 - Ensure that the wooden instrument fits between the blades and through the reel and is long enough to provide leverage to release the blockage.
1. Park the machine on a level surface.
 2. Move the traction pedal to the NEUTRAL position, engage the parking brake, and shut off the cutting units.
 3. Lower the cutting units to the ground or securely lock them in the transport positions.
 4. Shut off the engine, remove the key, and wait for all moving parts to stop.
 5. Release all stored energy devices.
 6. Check that all moving parts are stationary.
 7. Using a suitable strong wooden instrument, remove the blockage. Ensure that the wooden instrument is properly supported in the cutting unit and avoid using excessive force to prevent damage.
 8. Remove the wooden instrument from the cutting unit before starting the engine.
 9. Repair or adjust the cutting unit if required.







Operating Tips

Becoming Familiar with the Machine

Before mowing grass, practice operating the machine in an open area. Start and shut off the engine. Operate in forward and reverse. Lower and raise the cutting unit, and engage and disengage them. When you feel familiar with the machine, practice operating it up and down slopes.

Understanding the InfoCenter Engine Warnings

If while operating the machine an icon displays on the InfoCenter warning you of a condition, stop the machine immediately and correct the problem. In the table that follows includes examples of the icons that may display:

Icon	Condition
	Engine coolant is too hot.
	Shut off the engine.
	Stationary regeneration is required.
	The power take-off is disabled.
	DPF ash accumulation.
	NOx control diagnosis malfunction

Mowing Grass

To maintain the high quality of cut, keep the rotational speed of the cutting units as high as possible. This requires high engine speed.

Cutting performance is best when cutting against the lie of the grass. To take advantage this effect, alternate the mowing direction between cuts.

Take care to not leave uncut strips of grass at the overlap at points between adjacent cutting units by avoiding tight turns.

Maximizing the Quality of Cut

The quality of cut deteriorates when the forward speed is too fast. Always balance the quality of cut with the required cutting rate, and set the forward speed accordingly.

Maximizing Engine Efficiency

Do not let the engine labor. If you notice that the engine starts to labor, reduce the forward speed or increase the height of cut. Ensure that the cutting unit blades are sharp.

Driving the Machine in Transport Mode

Important: Take care when driving the machine over obstacles such as roadside curbs.

Always travel at slow speed over obstacles to prevent damage to the tires, wheels, and steering system. Ensure that the tires are inflated to the recommended pressures.

Always disengage the cutting unit drive when driving the machine across areas with no grass. Grass lubricates the cutting edges while mowing. Excessive heat builds if the cutting units are run when not mowing, resulting in rapid wear. For this reason, reduce cutting speed when mowing lightly grassed areas or when the grass is dry. Be careful when driving between objects so that you do not accidentally damage the machine or the cutting units.

Using the Rear Roller Scrapers

For optimum grass discharge, remove the rear roller scrapers where conditions allow.

If mud and grass start to build up on the rollers, install the scrapers. When installing the scraper wires, tension them correctly.

After Operation

After Operation Safety

General Safety

- Park the machine on a level surface.
- Disengage and lower the cutting units.
- Engage the parking brake.
- Shut off the engine and remove the key.
- Wait for all movement to stop.
- Allow the machine to cool before adjusting, servicing, cleaning, or storing it.
- To help prevent fires, ensure that the cutting units, drives, mufflers, cooling screens, and engine compartment are free from grass and debris buildup. Clean up oil or fuel spills.
- Disengage the drive to the attachment whenever you are hauling or not using the machine.
- Maintain and clean the seat belt(s) as necessary.
- Do not store the machine or fuel container where there is an open flame, spark, or pilot light, such as on a water heater or on other appliances.

Identifying the Tie-Down Points

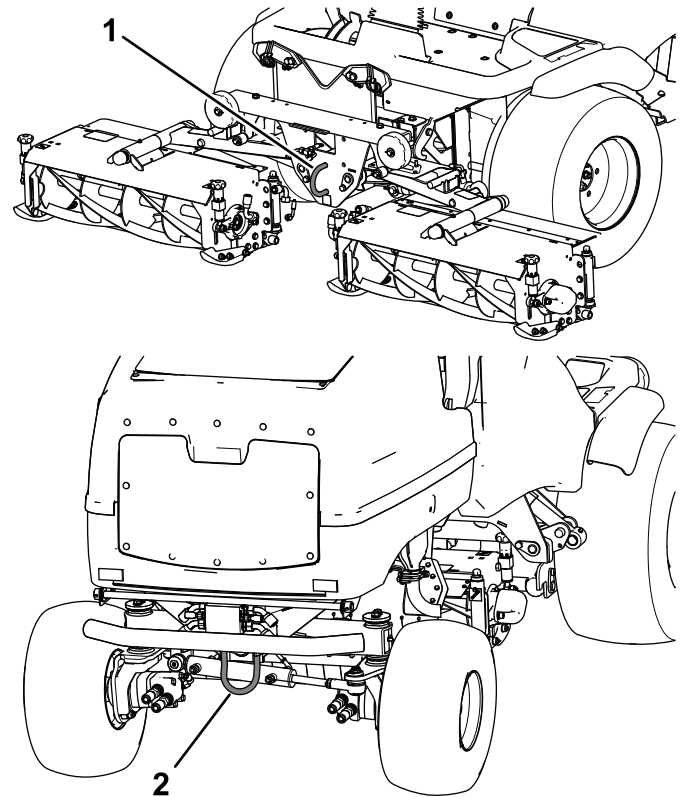

Figure 30

g281268

1. Front tie-down point
2. Rear tie-down point

Hauling the Machine

- Use full-width ramps for loading the machine onto a trailer or truck.
- Tie the machine down securely.

Towing the Machine

Ensure that the towing vehicle can control the combined weight of both vehicles; refer to [Specifications \(page 18\)](#).

Raising the Cutting Units

Whenever possible, raise and latch the cutting units before towing the machine.

Releasing the Wheel-Motor Brakes

1. Engage the parking brake and chock the wheels of the towing vehicle.
2. Chock the front wheels of the machine.

3. Raise the platform forward; refer to [Raising the Platform \(page 37\)](#).
4. Remove the 2 bolts 12 x 40 mm and 2 washers 12 mm stored in the platform support rails ([Figure 31](#)).

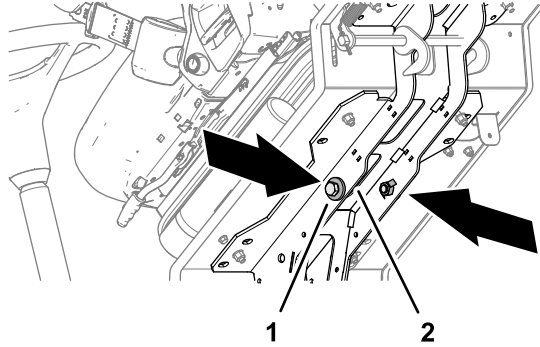

Figure 31

g292366

1. Bolt 12 x 40 mm and washers 12 mm
2. Platform support rail

5. Connect a **rigid** tow bar between the front tow ring of the machine and the tow vehicle ([Figure 32](#)).

Note: If needed, use the rear tow ring of the machine to position the machine to provide clearance, and use the front tow ring to tow the machine.

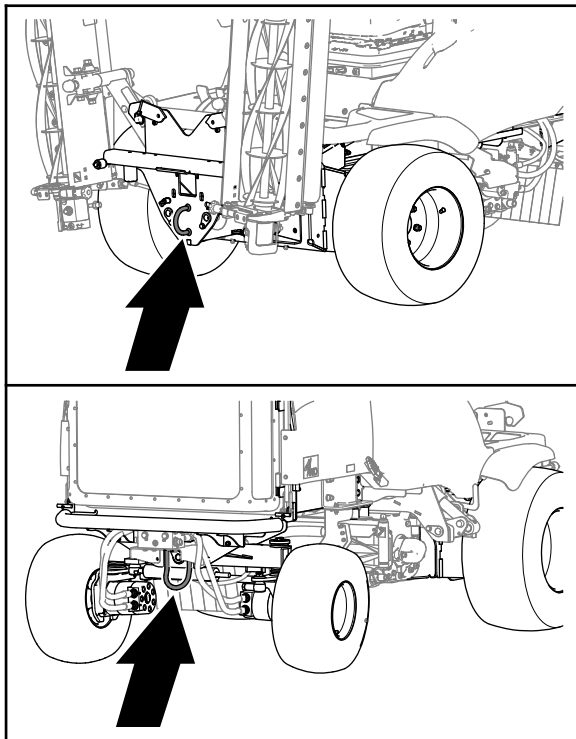

Figure 32

g328268

6. At the right, front wheel motor brake assembly remove the hex plug ([Figure 33](#)).

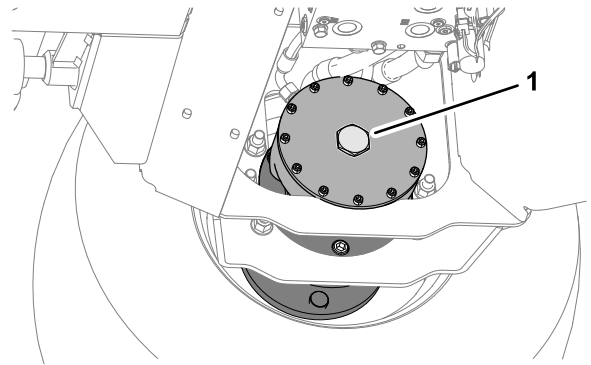

Figure 33

g292377

1. Hex plug

7. Assemble a bolt 12 x 40 mm and washer 12 mm into the hole at the center of the motor end plate ([Figure 34](#)).

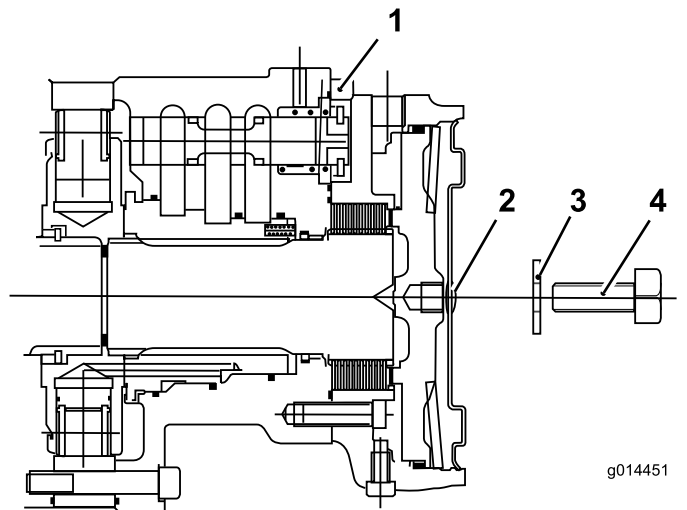

Figure 34

g014451

g014451

1. Front wheel motor
2. Hex plug
3. Washer 12 mm
4. Bolt 12 x 40 mm

8. Tighten the bolt in the threaded hole in the brake piston until the brake releases ([Figure 34](#)).
9. Repeat steps 6 through 8 for the brake at the left side of the machine.

Bypassing the Transmission Pump

1. Use an 8 mm (5/16 inch) hex key to rotate the 2 socket head plugs for the transmission pump-relief valves counterclockwise 3 full turns ([Figure 35](#)).

Important: You must manually steer the machine while it is towed. When the engine is shut off, there is no hydraulic steering assist—steering the machine feels heavy.

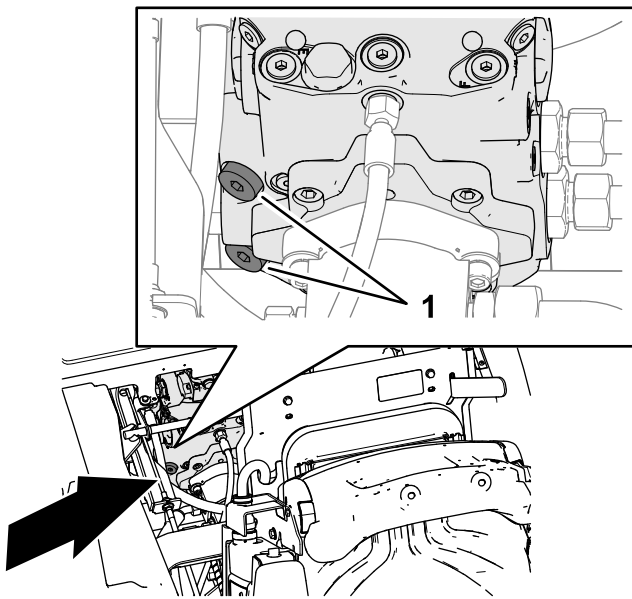

Figure 35

g380665

1. Socket head plugs (transmission pump-relief valves)

-
2. Lower and latch the platform; refer to [Lowering the Platform \(page 37\)](#).
 3. Remove the wheel chocks

Towing the Machine

Important: Do not tow the machine faster than 3 to 5 km/h (2 to 3 mph) and for no longer than 3 minutes, otherwise internal damage to the transmission may occur.

- Use the front tow ring to tow the machine.
- Tow the machine a short distance, at slow speed, for no longer than 3 minutes.

Restoring the Transmission Pump

1. Chock the front wheels.
2. Raise the platform forward; refer to [Raising the Platform \(page 37\)](#).
3. Use an 8 mm (5/16 inch) hex key to rotate the 2 socket head plugs for the transmission pump-relief valves clockwise 3 turns ([Figure 36](#)).

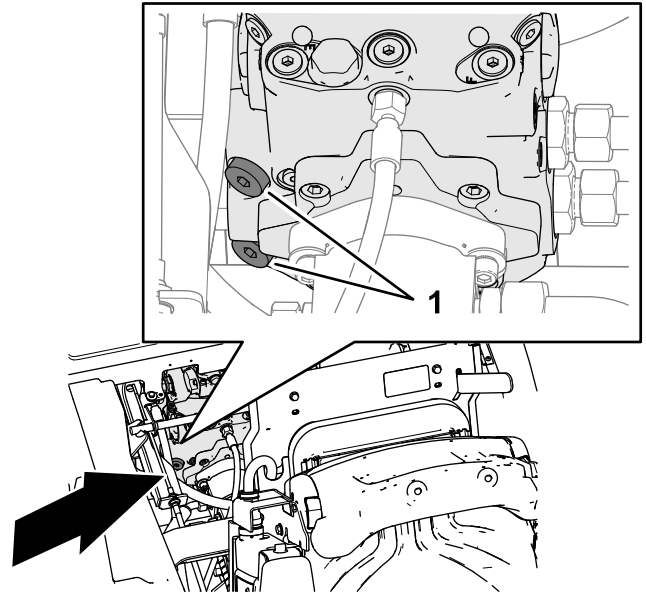

Figure 36

g380665

1. Socket head plugs (transmission pump-relief valves)

-
4. Torque the 2 socket head plugs to 81 N·m (59.7 ft-lb).

Restoring the Brakes

1. Remove the bolt 12 x 40 mm and washer 12 mm from the hole at the center of the motor end plate (Figure 37).

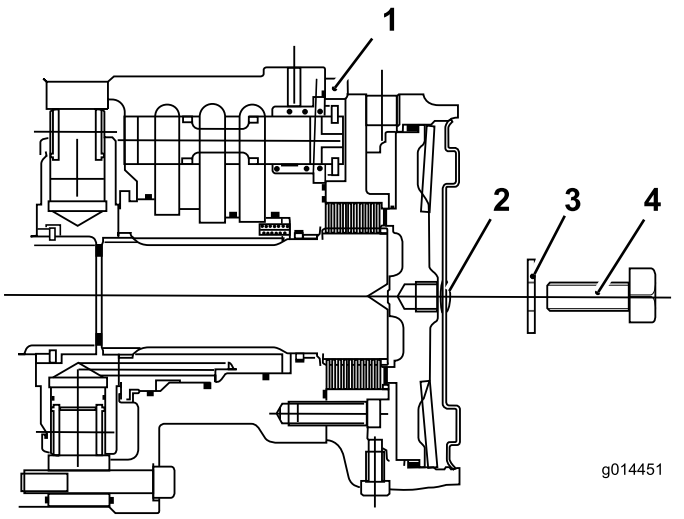

Figure 37

- | | |
|----------------------|--------------------|
| 1. Front wheel motor | 3. Washer 12 mm |
| 2. Hex plug | 4. Bolt 12 x 40 mm |

2. Install the hex plug into the motor end plate (Figure 38).

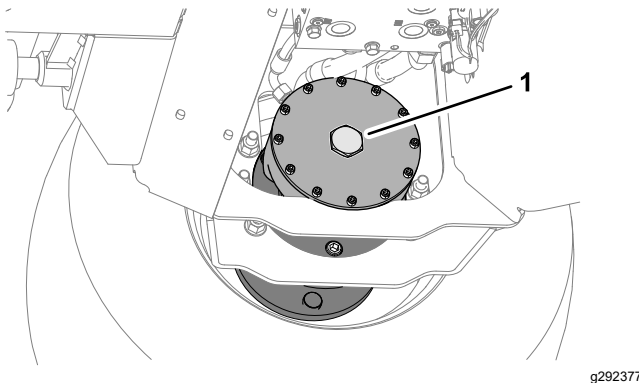

Figure 38

1. Hex plug

3. Repeat steps 1 through 2 for the brake at the other side of the machine.
4. Remove the wheel chocks.
5. Disconnect the tow bar.

Note: The transmission and brakes are ready for operation.

6. Stow the 2 bolts 12 x 40 mm and 2 washers 12 mm stored in the platform support rails (Figure 39).

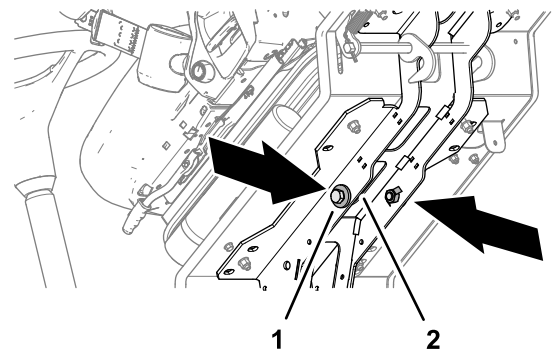

Figure 39

- | | |
|--------------------------------------|--------------------------|
| 1. Bolt 12 x 40 mm and washers 12 mm | 2. Platform support rail |
|--------------------------------------|--------------------------|

7. Lower the platform; refer to Lowering the Platform (page 37).
8. Disconnect the tow vehicle.
9. Check the brake operation of the machine.

⚠ WARNING

Operating the machine without the braking system working properly may cause you to lose control of the machine, resulting in serious injury to you and bystanders.

Before using the machine, ensure that the braking system operates correctly. Carry out initial checks driving the machine at slow speed. Do not operate the machine with a damaged or disconnected braking system.

Maintenance

Download a free copy of the electrical or hydraulic schematic by visiting www.toro.com/en-gb and searching for your machine from the Manuals link on the home page.

Note: Determine the left and right sides of the machine from the normal operating position.

Maintenance Safety

- Before you leave the operator’s position, do the following:
 - Park the machine on a level surface.
 - Disengage and lower the cutting units.
 - Engage the parking brake.
 - Shut off the engine and remove the key.
 - Wait for all movement to stop.
 - Allow the machine to cool before adjusting, servicing, cleaning, or storing it.
- Wear appropriate clothing, including eye-protection; long trousers and substantial, slip-resistant footwear. Keep hands, feet, clothing, jewelry, and long hair away from moving parts.
- Allow machine components to cool before performing maintenance.
- If possible, do not perform maintenance while the engine is running. Keep away from moving parts.
- Operate the engine only in well-ventilated areas. Exhaust gases contain carbon monoxide, which is lethal if inhaled.
- Support the machine with jack stands whenever you work under the machine.
- Carefully release pressure from components with stored energy.
- Keep all parts of the machine in good working condition and all hardware tightened.
- Replace all worn or damaged decals.
- To ensure safe, optimal performance of the machine, use only genuine Toro replacement parts. Replacement parts made by other manufacturers could be dangerous, and such use could void the product warranty.

Recommended Maintenance Schedule(s)

Maintenance Service Interval	Maintenance Procedure
After the first hour	<ul style="list-style-type: none"> • Torque the wheel lug nuts.
After the first 10 hours	<ul style="list-style-type: none"> • Torque the wheel lug nuts.
After the first 50 hours	<ul style="list-style-type: none"> • Check the alternator-belt tension.
Before each use or daily	<ul style="list-style-type: none"> • Check the forward and reverse traction pedal action. • Check the interlock switches: operator presence, cutting-unit drive interlock, parking brake interlock, and transmission neutral interlock. • Lubricate the grease-daily fittings. • Check the air filter-blockage indicator. • Check the engine-oil level. • Drain water or other contaminants from the water separator. • Check the tire air pressure in the front and rear tires. • Check the coolant level. • Remove debris from the screen and radiator/oil cooler. • Check the hydraulic lines and hoses. • Check the hydraulic-fluid level. • Inspect the seat belt. • Check the fasteners of the machine.
Every 50 hours	<ul style="list-style-type: none"> • Lubricate the grease every 50-hour fittings. • Service the battery.
Every 250 hours	<ul style="list-style-type: none"> • Torque the wheel lug nuts. • Check the transmission-control cable. • Check the alternator-belt tension. • Inspect the cooling-system hoses.

Maintenance Service Interval	Maintenance Procedure
Every 500 hours	<ul style="list-style-type: none"> • Replace the primary air filter. • Change the engine oil and filter. • Replace the fuel filter. • Replace the engine fuel filter. • Check the fuel lines and connections for deterioration, damage, or loose connections • Check the electrical system. • Check the rear wheel alignment. • If you are not using the recommended hydraulic fluid or have ever filled the reservoir with an alternative fluid, replace the hydraulic filters. • If you are not using the recommended hydraulic fluid or have ever filled the reservoir with an alternative fluid, change the hydraulic fluid.
Every 1,000 hours	<ul style="list-style-type: none"> • Adjust the engine valves. • If you are using the recommended hydraulic fluid, replace the hydraulic filters. • If you are using the recommended hydraulic fluid, change the hydraulic fluid.
Every 1,500 hours	<ul style="list-style-type: none"> • Inspect the crankcase breather system. • Flush and replace the coolant.
Every 3,000 hours	<ul style="list-style-type: none"> • Disassemble, clean, and assemble the soot filter of the DPF. • Inspect the ECU and related sensors and actuators. • Inspect, clean, and test the exhaust gas recirculation (EGR) valve. • Inspect and test the intake throttle valve. • Inspect and clean the injectors.
Every 2 years	<ul style="list-style-type: none"> • Replace all moving hoses. • Replace the transmission cable.

Daily Maintenance Checklist

Duplicate this page for routine use.

Maintenance Check Item	For the week of:						
	Mon.	Tues.	Wed.	Thurs.	Fri.	Sat.	Sun.
Check the engine oil level.							
Check the air filter-blockage indicator.							
Drain water the fuel/water separator.							
Check for fluid leaks.							
Check the cooling system.							
Remove debris from the screen and radiator/oil cooler							
Grease the bearings, bushings, and pivot points. ²							
Check the tire air pressure.							
Check the hydraulic fluid level.							
Check the hydraulic lines and hoses.							
Check the fasteners of the machine.							
Check the cutting units.							
Check the reel-to-bedknife adjustment.							
Check the height-of-cut adjustment.							
Inspect the seat belt.							
Check the traction pedal operation.							
Check the instrument operation.							
Check unusual engine noises. ¹							
Check the interlock switch operation.							
Check the brake operation.							
Check unusual operating noises.							
Wash the machine. ²							
Touch-up damaged paint.							

1. Check the glow plug and injector nozzles if the engine starts hard, produces excess smoke, or runs rough.
 2. Grease the machine immediately after every washing, regardless of the interval listed

Important: Refer to your engine owner's manual for additional maintenance procedures.

Notation for Areas of Concern

Inspection performed by:		
Item	Date	Information
1		
2		
3		
4		
5		
6		

Pre-Maintenance Procedures

Raising the Platform

1. Move the platform-latch handle (Figure 40) toward the front of the machine until the latch hooks clear the locking bar.

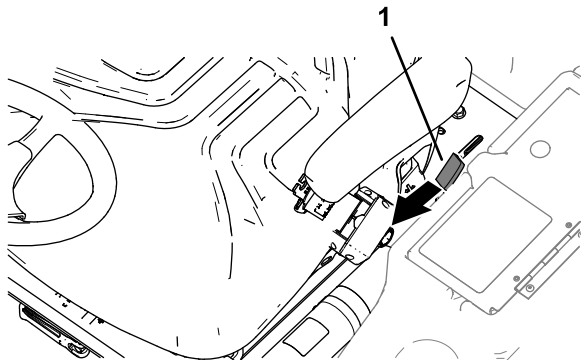

Figure 40

g290373

1. Platform-latch handle

2. Raise the platform (Figure 41).

Note: The gas lift cylinder assists lifting the platform.

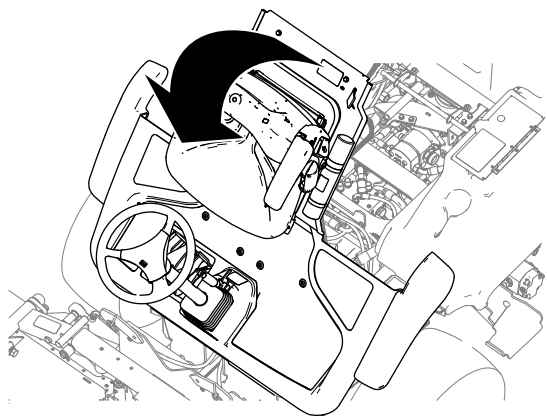

Figure 41

g290372

Lowering the Platform

⚠ WARNING

Operating the machine with the platform unlatched may cause you to lose control of the machine, resulting in serious injury to you and bystanders.

Never operate the machine without first checking that the operator platform latching mechanism is fully engaged and in good working order.

1. Lower the platform carefully (Figure 42).

Note: The gas lift cylinder helps support the platform.

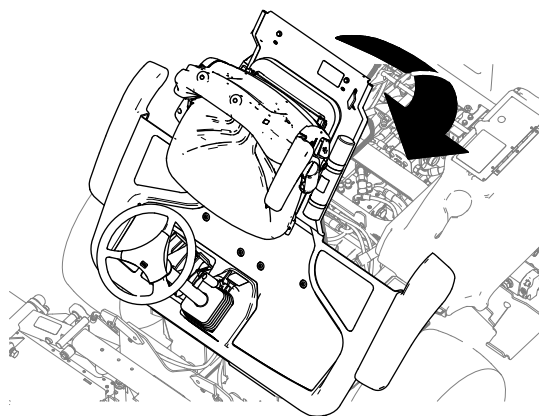

Figure 42

g290371

2. As the platform nears the fully lowered position, move the platform-latch handle (Figure 43) toward the front of the machine.

Note: This ensures that the latch hooks clear the locking bar.

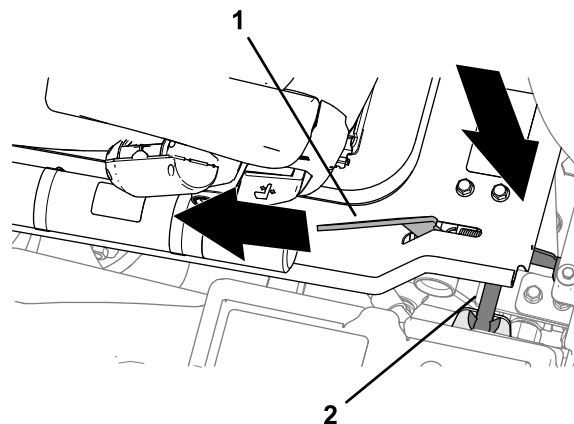

Figure 43

g290369

1. Platform-latch handle
2. Locking bar

- Fully lower the platform and move the platform-latch handle toward the rear of the machine until the latch hooks fully engage the locking bar (Figure 44).

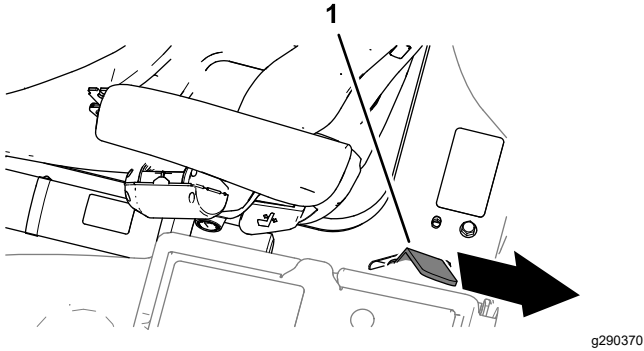

Figure 44

- Platform-latch handle

Removing the Storage Compartment

- At the left side of the operator's platform, open the door of the storage compartment (Figure 45).

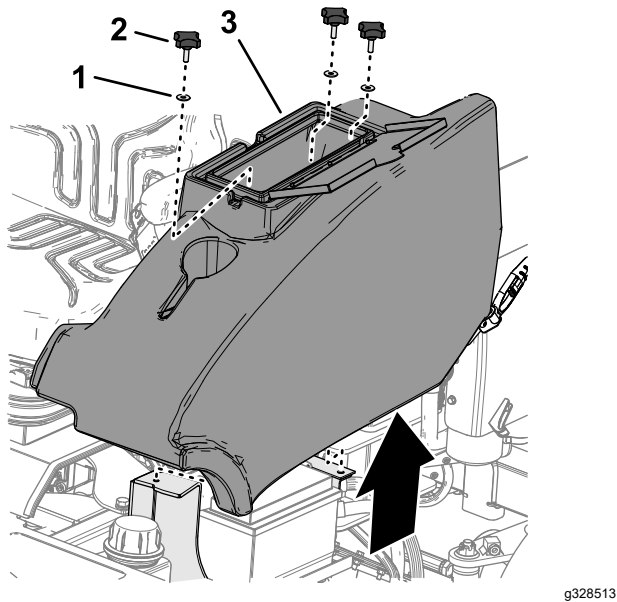

Figure 45

- Washer
- Knob
- Storage compartment

- Remove the 3 knobs and 3 washers that secure the storage compartment to the machine, and remove the compartment (Figure 45).

Installing the Storage Compartment

- Align the holes on the bottom of the storage compartment with the holes in the chassis brackets.
- Assemble the storage compartment to the machine with the 3 knobs and 3 washers (Figure 46)

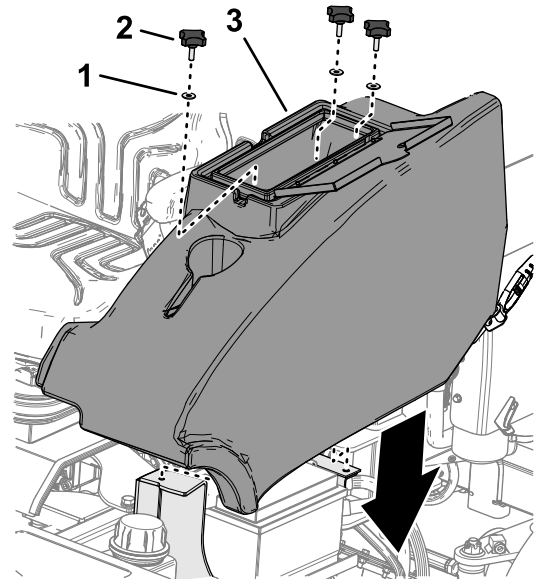

Figure 46

- Washer
- Knob
- Storage compartment

- Close the storage-compartment door.

Locating the Lift Points

Note: Use jack stands to support the machine when you lift it.

⚠ WARNING

Mechanical or hydraulic jacks may fail to support the machine and cause serious injury.

Use jack stands when supporting the machine.

- Front—under the front arm mount
- Rear—axle tube on the rear axle

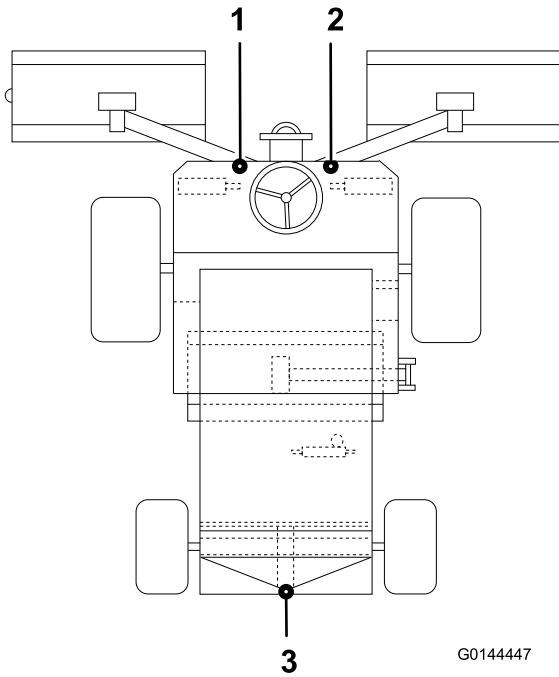

Figure 47

- 1. Front left lift point
- 2. Front right lift point
- 3. Rear lift point

Lubrication

Greasing the Bearings, Bushings, and Pivots

Service Interval: Before each use or daily—Lubricate the grease-daily fittings.

Every 50 hours—Lubricate the grease every 50-hour fittings.

Important: Lubricate the bearings, bushings, and pivot points immediately after every washing, regardless of the service interval listed.

Grease specification: No. 2 lithium grease.

- Use 1 pump of grease on the height-of-cut adjusters and 3 pumps of grease on all other grease fittings
- Refer to [Figure 48](#) for the grease fitting locations.
- Replace any damaged grease fittings.

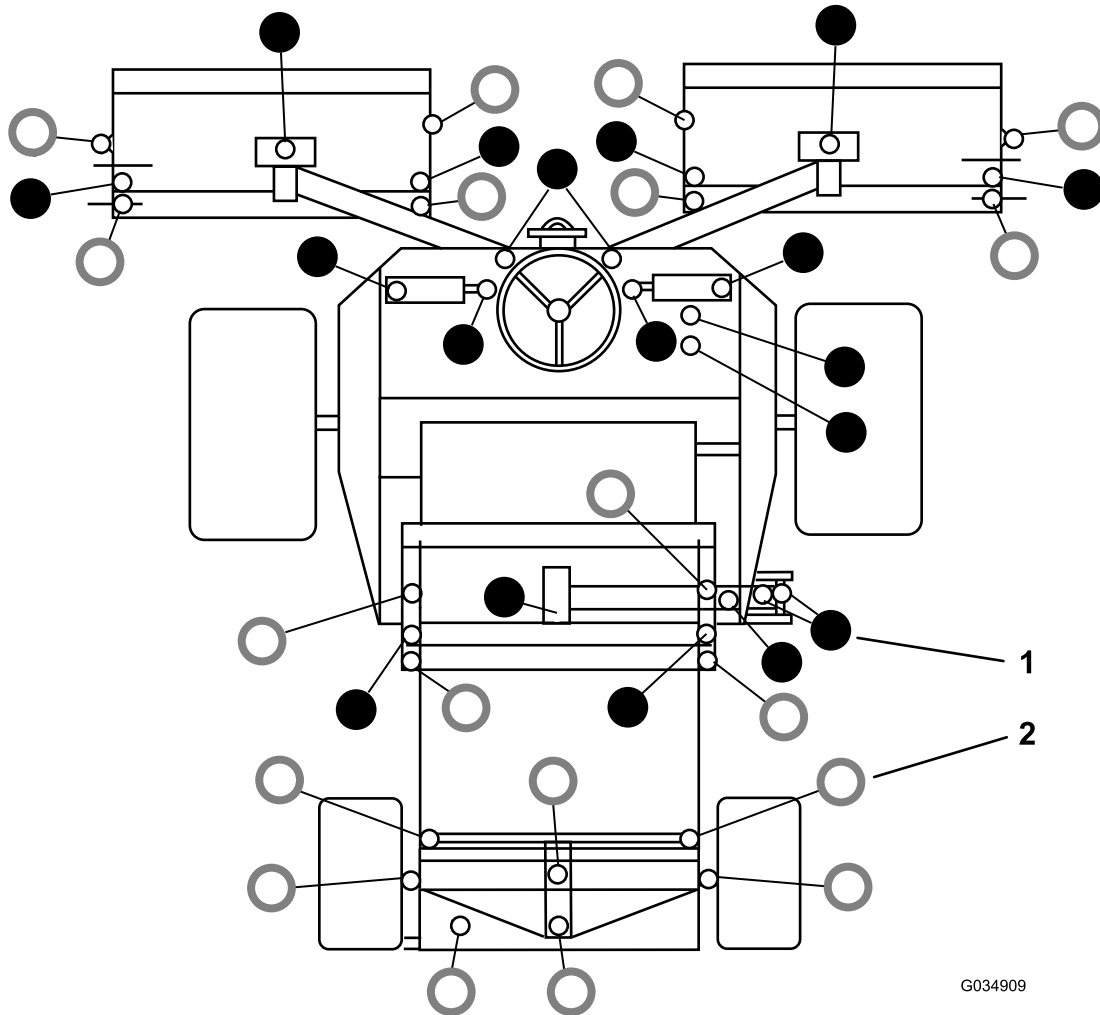

G034909

g034909

Figure 48

1. ● – Grease every 50 hours

2. ○ – Grease daily

Engine Maintenance

Engine Safety

- Shut off the engine before checking the oil or adding oil to the crankcase.
- Do not change the governor speed or overspeed the engine.

Checking the Air Filter-Blockage Indicator

Service Interval: Before each use or daily

1. Open the hood.
2. Check the air filter-blockage indicator (Figure 49).

Important: If the indicator is red, inspect the primary air filter and replace it if it is dirty or damaged; refer to [Replacing the Primary Air Filter \(page 41\)](#).

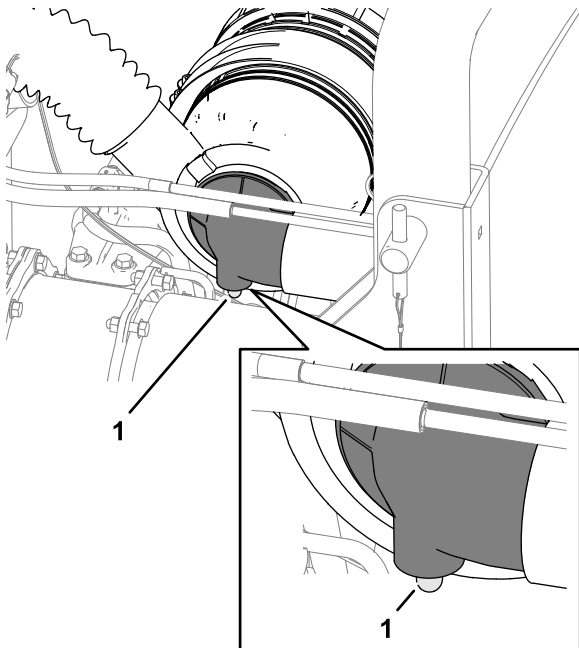

Figure 49

g292453

1. Filter-blockage indicator
-
3. If the filter-blockage indicator is not red, close the hood.

Replacing the Primary Air Filter

Service Interval: Every 500 hours

Check the air-cleaner body for damage that could cause an air leak. Replace the air-cleaner body if

damaged. Check the whole intake system for leaks, damage, or loose hose clamps.

Note: Service the primary air filter when the filter-blockage indicator (Figure 49) is red. Changing the air filter frequently increases the chance of dirt entering the engine when the filter is removed.

Important: Be sure that the cover is seated correctly and seals with the air-cleaner body.

1. Before removing the air-filter cover, use low pressure air (40 psi, clean and dry) to help remove large accumulations of debris packed outside of the filter canister.

Note: This cleaning process prevents debris from migrating into the intake when the filter is removed.

Important: Avoid using high-pressure air which could force dirt through the filter into the intake tract.

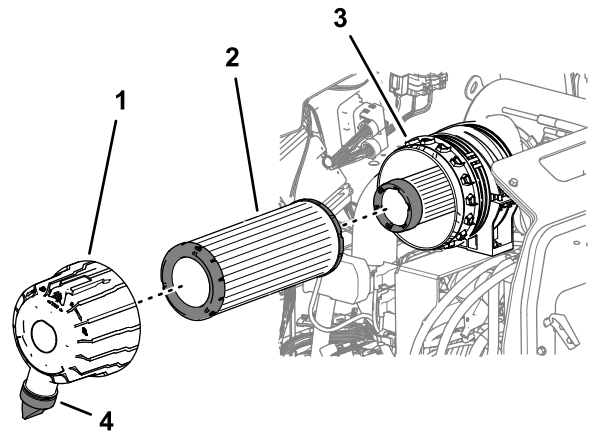

Figure 50

g292455

1. Air-filter cover
2. Primary air filter
3. Canister
4. Dirt ejection port

-
2. Remove the cover from the air-cleaner body.
 3. Remove the primary air filter (Figure 50).

Important: Do not clean and reuse a used element because of possible damage to the filter element.

4. Inspect the new filter for shipping damage, checking the sealing end of the filter and the body.
5. Insert the new filter by applying pressure to the outer rim of the element to seat it in the canister.

Important: Do not use a damaged element.

Important: Do not apply pressure to the flexible center of the filter.

6. Clean the dirt ejection port located in the air-filter cover. Remove the rubber outlet valve from the

cover, clean the cavity in the valve, and install the outlet valve into the air-filter cover.

- Align the dirt ejection port air-filter cover between 5 o'clock to 7 o'clock when viewed from the end, assemble the cover to the canister, and secure the cover.
- Check the condition of the air-cleaner hoses.

Replacing the Safety Filter

The air filter has a secondary, safety filter element inside the primary air filter to prevent dislodged dust and other items from entering the engine while changing the main element.

Replace the safety filter; never clean it.

Important: Never attempt to clean the safety filter. If the safety filter is dirty, then the primary filter is damaged. Replace both filters.

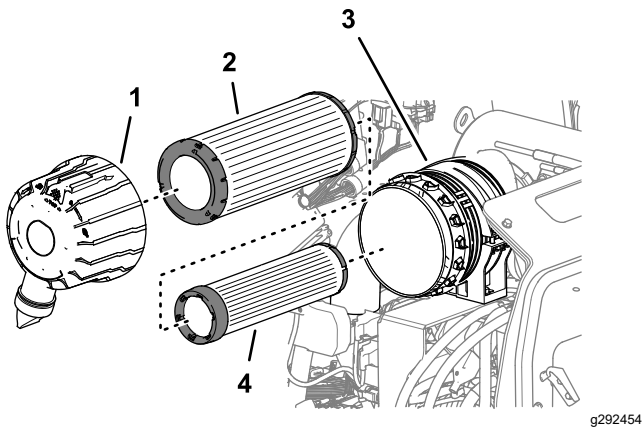

Figure 51

- | | |
|-----------------------|------------------|
| 1. Air-filter cover | 3. Canister |
| 2. Primary air filter | 4. Safety filter |

Servicing the Engine Oil

Oil Specification

Use high-quality, low-ash engine oil that meets or exceeds the following specifications:

- API service category CJ-4 or higher
- ACEA service category E6
- JASO service category DH-2

Important: Using engine oil other than API CJ-4 or higher, ACEA E6, or JASO DH-2 may cause the diesel particulate filter to plug or cause engine damage.

Use the following engine oil viscosity grade:

- Preferred oil: SAE 15W-40 (above 0°F)
- Alternate oil: SAE 10W-30 or 5W-30 (all temperatures)

Toro Premium Engine Oil is available from your authorized Toro distributor in either 15W-40 or 10W-30 viscosity grades. See the parts catalog for part numbers.

Checking the Engine-Oil Level

Service Interval: Before each use or daily

Important: Check the engine oil daily. If the engine-oil level is above the full mark on the dipstick, the engine oil may be diluted with fuel.

If the engine oil level is above the full mark, change the engine oil.

The best time to check the engine oil is when the engine is cool before it has been started for the day. If it has already been run, allow the oil to drain back down to the sump for at least 10 minutes before checking. If the oil level is at or below the Add mark on the dipstick, add oil to bring the oil level to the Full mark. Do not overfill the engine with oil.

Important: Keep the engine oil level between the upper and lower limits on the oil gauge; the engine may fail if you run it with too much or too little oil.

1. Park the machine on a level surface, lower the cutting units, shut off the engine, engage the parking brake, and remove the key.
2. Unlock the engine-cover latches and open the engine cover.
3. Remove the dipstick, wipe it clean, install the dipstick into the tube, and pull it out again. The oil level should be between the FULL and ADD marks (Figure 52).

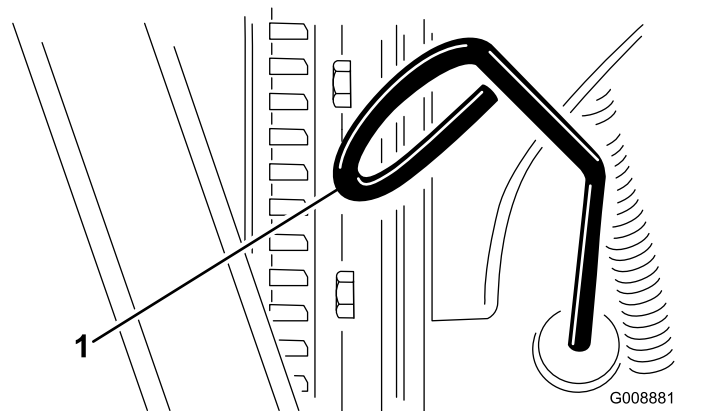

Figure 52

1. Dipstick

- If the oil level is low, remove the fill cap and add oil until it is between the FULL and ADD marks (Figure 52).

Note: Do not overfill the engine.

- Install the oil-fill cap and dipstick.
- Close the engine cover and secure it with the latches.

Crankcase Oil Capacity

5.5 L (5.8 US qt) with the filter

Changing the Engine Oil and Filter

Service Interval: Every 500 hours—Change the engine oil and filter.

- Remove the drain plug and let the oil flow into a drain pan (Figure 53).

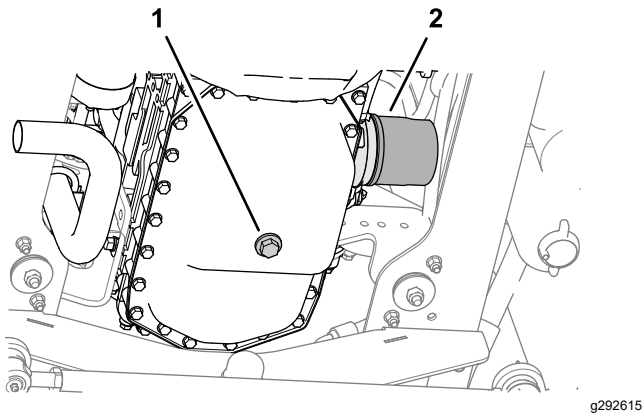

Figure 53

- Engine-oil drain plug
- Oil filter

- When all the oil is drained, install the drain plug and tighten it to 54 to 63 N·m (39 to 47 in-lb).
- Remove the oil filter.
- Apply a light coat of clean oil to the oil filter gasket.
- Thread the oil filter onto the engine until it contacts the mounting surface, and tighten the filter an additional turn.

Important: Do not overtighten the filter.

- Add oil to the crankcase; refer to [Oil Specification \(page 42\)](#) and [Checking the Engine-Oil Level \(page 42\)](#).

Servicing the Diesel-Oxidation Catalyst (DOC) and the Soot Filter

Service Interval: Every 3,000 hours—Disassemble, clean, and assemble the soot filter of the DPF. Clean the soot filter if engine faults SPN 3251 FMI 0, SPN 3720 FMI 0, or SPN 3720 FMI 16 display in the InfoCenter; contact an Authorized Service Dealer.

If engine faults CHECK ENGINE SPN 3251 FMI 0, CHECK ENGINE SPN 3720 FMI 0, or CHECK ENGINE SPN 3720 FMI 16 display in the InfoCenter (Figure 54), clean the soot filter using the steps that follow:

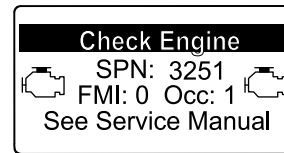

g214715

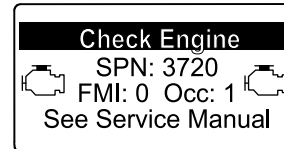

g213864

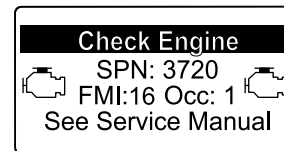

g213863

Figure 54

- Refer to the Engine section in the *Service Manual* for information on disassembling and assembling the diesel-oxidation catalyst and the soot filter of the DPF.
- Refer to your authorized Toro distributor for diesel-oxidation catalyst and the soot filter replacement parts or service.
- Contact your authorized Toro distributor to reset the engine ECU after you install a clean DPF.

Extended Engine Maintenance

Service Interval: Every 1,000 hours Refer to the *Engine Service Manual*.

Every 1,500 hours—Inspect the crankcase breather system. Contact an Authorized Service Dealer.

Every 3,000 hours—Inspect the ECU and related sensors and actuators. Contact an Authorized Service Dealer.

Every 3,000 hours—Inspect, clean, and test the exhaust gas recirculation (EGR) valve. Contact an Authorized Service Dealer.

Every 3,000 hours—Inspect and test the intake throttle valve. Contact an Authorized Service Dealer.

Every 3,000 hours—Inspect and clean the injectors. Contact an Authorized Service Dealer.

Fuel System Maintenance

⚠ DANGER

Under certain conditions, fuel and fuel vapors are highly flammable and explosive. A fire or explosion from fuel can burn you and others and can cause property damage.

- **Fill the fuel tank outdoors, in an open area, when the engine is off and is cold. Wipe up any fuel that spills.**
- **Do not fill the fuel tank completely full. Add fuel to the fuel tank until the level is 25 mm (1 inch) below the top of the tank, not the filler neck. This empty space in the tank allows the fuel to expand.**
- **Never smoke when handling fuel, and stay away from an open flame or where spark can ignite fuel fumes.**
- **Store fuel in a clean, safety-approved container and keep the cap in place.**

Fuel Maintenance

This *Operator's Manual* contains more detailed fuel and fuel system maintenance information than the Yanmar® engine *Owner's Manual*, which is a general-purpose reference relating to fuel and fuel maintenance.

Ensure that you understand that the fuel system maintenance, fuel storage, and fuel quality require your attention to avoid downtime and extensive engine repairs.

The fuel system has extremely tight tolerances due to the emissions and control requirements. Diesel fuel quality and cleanliness is more important for the longevity of today's high-pressure common rail (HPCR) fuel-injection system used on diesel engines.

***Important:* Water or air in the fuel system will damage your engine! Do not assume that new fuel is clean. Ensure that your fuel is from a quality supplier, store your fuel correctly, and use your fuel supply within 180 days.**

***Important:* If you do not follow the procedures for fuel filter replacement, fuel system maintenance, and fuel storage, the engine fuel system could fail prematurely. Perform all fuel system maintenance at the specified intervals or whenever the fuel is contaminated or its quality is poor.**

Storing Fuel

Appropriate fuel storage is critical for your engine. Proper maintenance of fuel storage tanks is often overlooked and leads to the contamination of fuel delivered to the machine.

- Acquire only enough fuel that you will consume within 180 days. Do not use fuel that has been stored for more than 180 days. This helps eliminate water and other contaminants in the fuel.
- If you do not remove the water from the storage tank or machine fuel tank, it can lead to rust or contamination in the storage tank and fuel system components. Tank sludge developed by mold, bacteria, or fungus restricts flow and clogs the filter and fuel injectors.
- Inspect your fuel storage tank and machine fuel tank regularly to monitor the fuel quality in the tank.
- Ensure that your fuel comes from a quality supplier.
- If you find water or contaminants in your storage tank or machine fuel tank, work with your fuel provider to correct the problem and perform all fuel system maintenance.
- Do not store diesel fuel in tanks or canisters made with zinc-plated components.

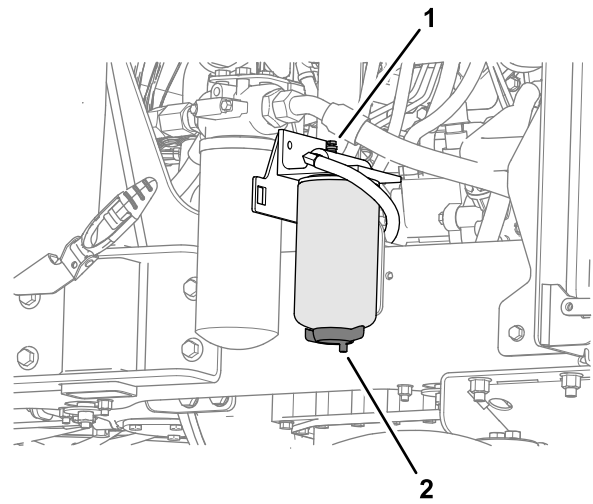

Figure 55

g292479

1. Vent screw
2. Drain valve (water separator filter)

4. Tighten the drain valve at the bottom of the filter canister and close the vent screw at the top of the canister mount.
5. Prime the fuel system; refer to [Priming the Fuel System \(page 45\)](#).

Servicing the Water Separator

Service Interval: Before each use or daily—Drain water or other contaminants from the water separator.

1. Park the machine on a level surface, lower the cutting units, engage the parking brake, shut off the engine, and remove the key.
2. Place a clean container under the fuel filter.
3. Loosen the drain valve at the bottom of the filter canister and open the vent screw at the top of the canister mount.

Priming the Fuel System

Prime the fuel system under the following conditions:

- Before starting the engine for the first time.
- If you run out of fuel and then add new fuel to the system.
- After performing maintenance to the fuel system, such as changing the fuel filter, draining the water separator, or replacing a fuel-system component.

To prime the fuel system, rotate the key switch to the ON position for 10 to 15 seconds to allow the electric fuel pump to prime the fuel system.

Important: Do not use the starter motor to crank the engine to prime the fuel system. You will damage the starter motor.

Replacing the Fuel-Water Filter

Service Interval: Every 500 hours

Important: Replace the fuel filter canister periodically to prevent wear of the fuel injection pump plunger or the injection nozzle, due to dirt in the fuel.

1. Place a clean container under the fuel filter canister ([Figure 56](#)).

2. Drain the fuel filter canister; refer to [Servicing the Water Separator \(page 45\)](#).
3. Clean the area around the fuel filter and filter head ([Figure 56](#)).

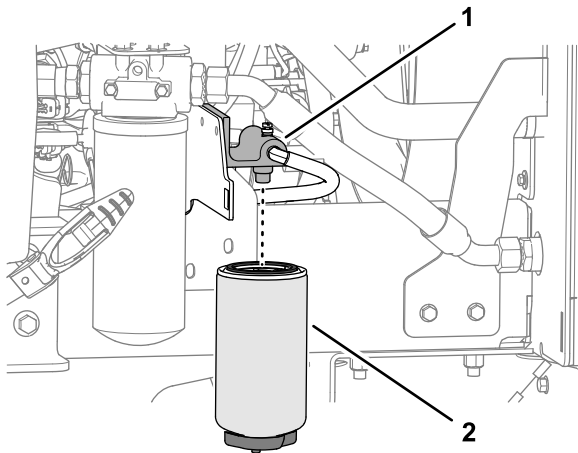

Figure 56

g292477

1. Filter head
2. Fuel filter

4. Remove the filter canister and clean the filter head ([Figure 56](#)).
5. Lubricate the gasket on the filter canister with clean diesel fuel.
6. Install the new filter canister by hand until the gasket contacts mounting surface.
7. Prime the fuel system; refer to [Priming the Fuel System \(page 45\)](#).

Servicing the Engine Fuel Filter

Service Interval: Every 500 hours—Replace the engine fuel filter.

Note: Refer to the engine owner's manual included with the machine for additional information.

1. Clean the area around the fuel-filter head ([Figure 57](#)).

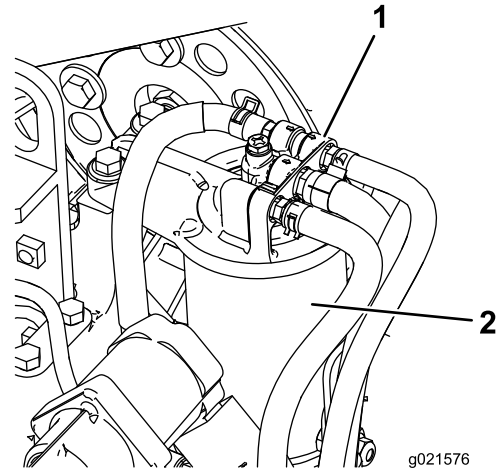

Figure 57

g021576

g021576

1. Fuel-filter head
2. Fuel filter

2. Remove the filter and clean the filter-head mounting surface ([Figure 57](#)).
3. Lubricate the filter gasket with clean diesel fuel.
4. Install the dry filter canister, by hand, until the gasket contacts the filter head, then rotate it an additional 1/2 turn.
5. Start the engine and check for fuel leaks around the filter head.

Checking the Fuel Lines and Connections

Service Interval: Every 500 hours (or yearly, whichever comes first).

Check the fuel lines and connections for deterioration, damage, or loose connections.

Fuel Pick-up Tube Screen

The fuel pick-up tube is located inside the fuel tank. The pick-up tube is equipped with a screen to help prevent debris from entering the fuel system. Remove the fuel pick-up tube and clean screen as required.

Electrical System Maintenance

Important: Before welding on the machine, disconnect both cables from the battery, both wire harness plugs from the electronic control modules, and the terminal connector from the alternator to prevent damage to the electrical system.

Electrical System Safety

- Disconnect the battery before repairing the machine. Disconnect the negative terminal first and the positive last. Connect the positive terminal first and the negative last.
- Charge the battery in an open, well-ventilated area, away from sparks and flames. Unplug the charger before connecting or disconnecting the battery. Wear protective clothing and use insulated tools.

Battery Maintenance

⚠ DANGER

Battery electrolyte contains sulfuric acid, which is fatal if consumed and causes severe burns.

- **Do not drink electrolyte and avoid contact with skin, eyes, or clothing. Wear safety glasses to shield your eyes and rubber gloves to protect your hands.**
- **Fill the battery where clean water is always available for flushing the skin.**

⚠ WARNING

Charging the battery produces gasses that can explode.

Never smoke near the battery and keep sparks and flames away from it.

Keep the terminals and the entire battery case clean because a dirty battery discharges slowly. To clean the battery, wash the entire case with a solution of baking soda and water. Rinse it with clear water.

Servicing the Battery

Service Interval: Every 50 hours (or weekly, whichever comes first)

Important: When removing the battery, always disconnect the negative (-) cable first.

Important: When installing the battery, always connect the negative (-) cable last.

Under normal operating conditions the battery does not require any further attention. If the machine has been subject to continuous use under high ambient temperature conditions, the battery electrolyte may require adding water.

1. Remove the storage compartment; refer to [Removing the Storage Compartment \(page 38\)](#).
2. Remove any corrosion from the battery terminals using a wire brush and to prevent further corrosion.
Note: Check the condition of the battery cables. Install new cables when current ones are showing signs of wear or damage and tighten any loose connections as necessary.
3. Apply Grafo 112X skin-over grease (Toro Part No. 505-47) or petroleum jelly to the terminals.
4. Clean the battery compartment.
5. Remove the cell covers and if needed add distilled water to a height 15 mm below the top of the battery. Install the cell covers.
6. Install the storage compartment; refer to [Installing the Storage Compartment \(page 38\)](#).

Checking the Electrical System

Service Interval: Every 500 hours

Inspect all electrical connections and cables and replace any which are damaged or corroded. Spray a good-quality water inhibitor onto exposed connections to prevent moisture ingress.

Checking the Fuses

1. Remove the storage compartment; refer to [Removing the Storage Compartment \(page 38\)](#).
2. Remove the fuse-block cover ([Figure 58](#))

Note: The fuse block is located next to the battery.

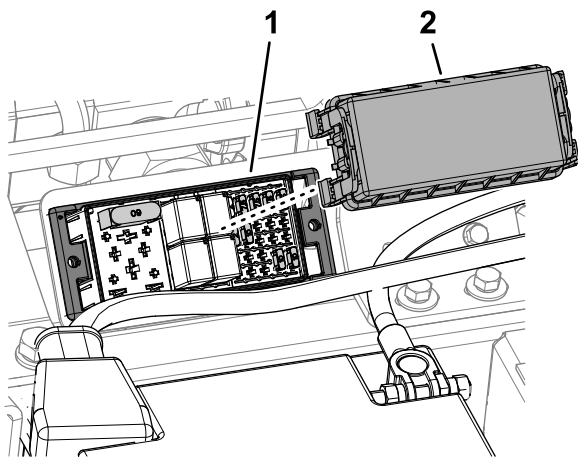

Figure 58

g328464

1. Fuse block
2. Fuse-block cover

3. Check for open fuses.

Note: There are 10 fuses in the electrical system.

4. Replace any open fuse with a fuse of equal amperage capacity.

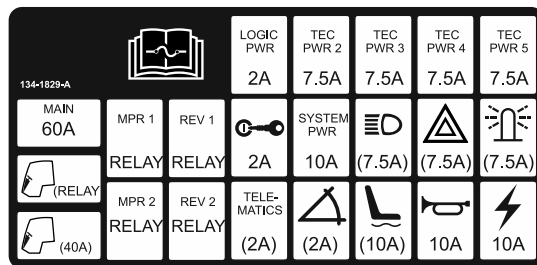

Figure 59

g328465

5. Install the fuse-block cover ([Figure 58](#)).
6. Install the storage compartment; refer to [Installing the Storage Compartment \(page 38\)](#).

Drive System Maintenance

Checking the Tire Air Pressure

Service Interval: Before each use or daily

Important: Maintain correct tire pressure in all tires to ensure correct contact with the turf.

Recommended tire pressure is 1 bar (14.5 psi) for general all around use. Adjust the tire air pressures according to the following table depending on operating conditions.

Tires	Tire Type	Recommended Tire Pressures		
		Turf Conditions	Road Conditions	Maximum Pressure
Front Axle	26 x 12.0 - 12 BKT turf pattern	0.7 bar (10 psi)	1.4 bar (20 psi)	1.4 bar (20 psi)
Rear Axle	20 x 10.0 - 8 BKT turf pattern	0.7 bar (10 psi)	1.4 bar (20 psi)	1.5 bar (22 psi)

Checking the Torque of the Wheel Nuts

Service Interval: After the first hour

After the first 10 hours

Every 250 hours

Front wheel nuts torque specification: 200 N·m (148 ft-lb)

Rear wheel nuts torque specification: 100 N·m (74 ft-lb)

⚠ WARNING

Failure to maintain proper torque of the wheel nuts could result in personal injury.

Maintain the proper torque on the wheel nuts.

Inspecting the Transmission Control Cable and Operating Mechanism

Service Interval: Every 250 hours

Check the condition and security of the cable and operating mechanism at the speed-control pedals and transmission pump ends.

- Remove buildup of dirt, grit, and other debris.
- Ensure that the ball joints are securely anchored and check that the mounting brackets and cable anchors are tight and free from cracks.
- Inspect end fittings for wear, corrosion, broken springs, and replace if necessary.
- Ensure that the rubber seals are correctly located and are in good condition.
- Ensure that the articulating sleeves supporting the inner cable are in good condition and firmly attached to the outer cable assembly at the crimped connections. If there are any signs of cracking or detachment install a new cable immediately.
- Check that sleeves, rods, and inner cable are free from bends, kinks, or other damage. If they are not, install a new cable immediately.
- With the engine shut off, operate the pedal controls through the entire range and ensure that the mechanism moves smoothly and freely to the neutral position without sticking or hanging up.

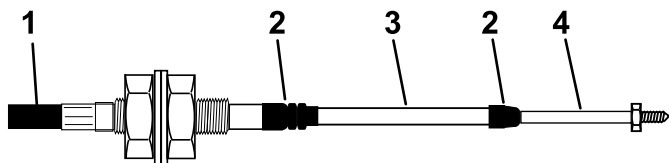

Figure 60

g014571
g014571

- | | |
|----------------|------------|
| 1. Outer cover | 3. Sleeve |
| 2. Rubber seal | 4. Rod end |

Checking the Rear Wheel Alignment

Service Interval: Every 500 hours

To prevent excessive tire wear and ensure safe machine operation, the front and back of the rear wheels must align within 5 mm (0.20 inch) or less.

1. Turn the steering wheel to align the rear wheels straight ahead.
2. At axle height, measure the distance between the front of the rear wheels and between the rear of the rear wheels.

Note: The wheels are aligned if the difference between the front and rear measurements are 5 mm (0.20 inch) or less.

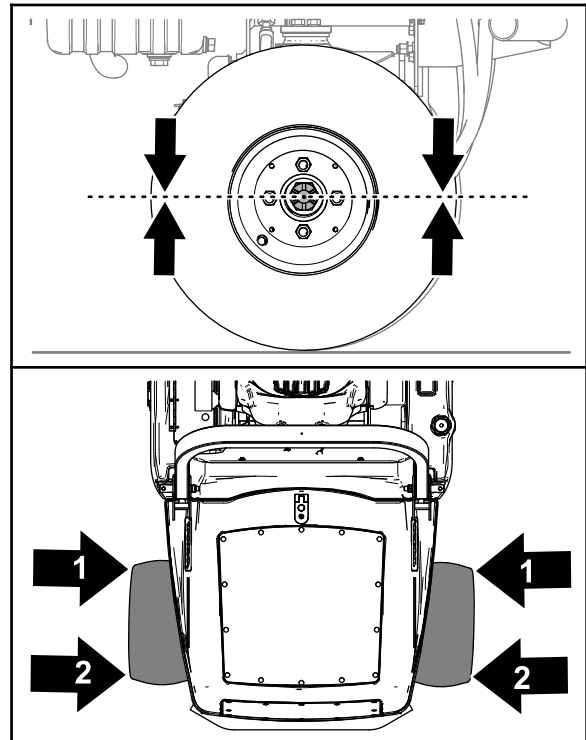

Figure 61

g348713

1. Front measurement
2. Rear measurement

3. If the difference between the front and rear measurements is greater than 5 mm (0.20 inch), align the rear wheels; refer to [Adjusting Rear Wheel Toe-In](#) (page 49)

Adjusting Rear Wheel Toe-In

1. At the front of the rear wheel, loosen the 2 jam nuts securing the track rod assembly to the rod ends ([Figure 62](#)).

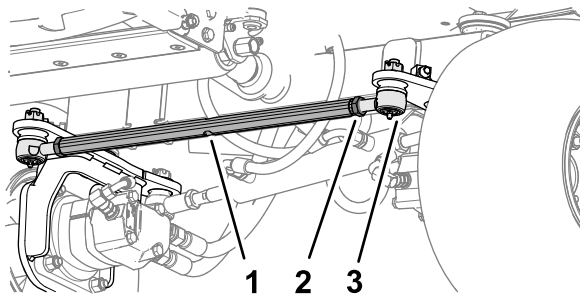

Figure 62

g348714

1. Track rod assembly
2. Jam nut
3. Rod end

2. Align the wheels by rotating the track rod (Figure 62).

Note: Use the wrench flats of the track rod to turn it.

3. At axle height, measure the distance between the front of the rear wheels and between the rear of the rear wheels.

Note: The wheels are aligned if the difference between the front and rear measurements are 5 mm (0.20 inch) or less.

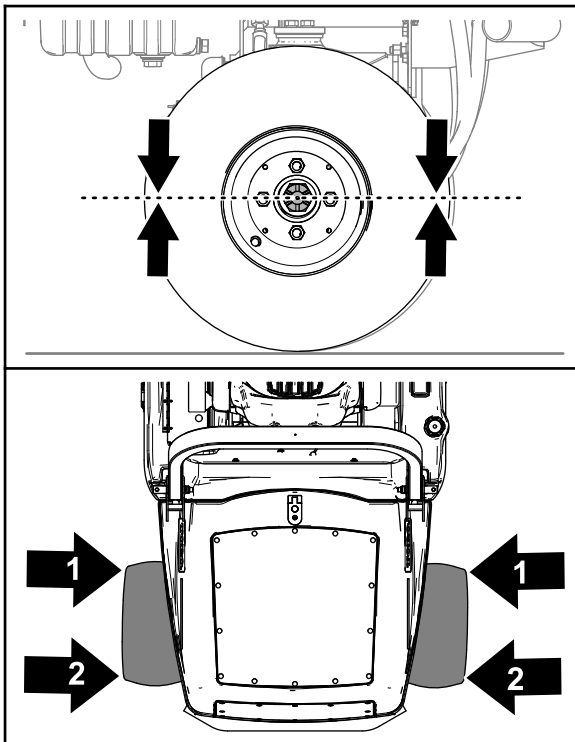

Figure 63

g348713

1. Front measurement
2. Rear measurement

4. Repeat steps 2 and 3 until the wheels are aligned.
5. Tighten the 2 jam nuts to secure the track rod assembly and the rod ends (Figure 62).

Cooling System Maintenance

Cooling System Safety

- Swallowing engine coolant can cause poisoning; keep out of reach from children and pets.
- Discharge of hot, pressurized coolant or touching a hot radiator and surrounding parts can cause severe burns.
 - Always allow the engine to cool at least 15 minutes before removing the radiator cap.
 - Use a rag when opening the radiator cap, and open the cap slowly to allow steam to escape.

Coolant Specification

The coolant reservoir is filled at the factory with a 50/50 solution of water and ethylene glycol base extended-life coolant.

Important: Use only commercially available coolants that meet the specifications listed in the Extended Life Coolant Standards Table.

Do not use conventional (green) inorganic-acid technology (IAT) coolant in your machine. Do not mix conventional coolant with extended-life coolant.

Coolant Type Table

Ethylene-Glycol Coolant Type	Corrosion Inhibitor Type
Extended-life antifreeze	Organic-acid technology (OAT)

Important: Do not rely on the color of the coolant to identify the difference between conventional (green) inorganic-acid technology (IAT) coolant and extended-life coolant.

Coolant manufacturers may dye extended-life coolant in one of the following colors: red, pink, orange, yellow, blue, teal, violet, and green. Use coolant that meets the specifications in the Extended Life Coolant Standards Table.

Extended Life Coolant Standards

ATSM International	SAE International
D3306 and D4985	J1034, J814, and 1941

Important: Coolant concentration should be a 50/50 mixture of coolant to water.

- **Preferred:** When mixing coolant from a concentrate, mix it with distilled water.

- **Preferred option:** If distilled water is not available, use a pre-mix coolant instead of a concentrate.
- **Minimum requirement:** If distilled water and pre-mix coolant are not available, mix concentrated coolant with clean drinkable water.

Checking the Coolant Level

Service Interval: Before each use or daily

⚠ CAUTION

If the engine has been running, the pressurized, hot coolant can escape and cause burns.

- Do not open the radiator cap when the engine is running.
- Use a rag when opening the radiator cap, and open the cap slowly to allow steam to escape.

1. Check the level of coolant in the expansion tank (Figure 64).

The coolant level should be between the marks on the side of the tank.

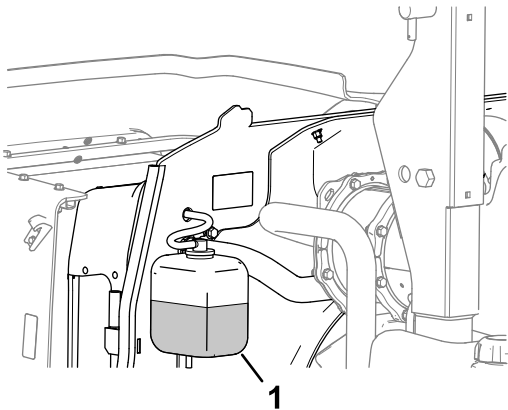

Figure 64

g330219

1. Expansion tank

2. If the coolant level is low, remove the expansion-tank cap and replenish the system. **Do not overfill.**
3. Install the expansion-tank cap.

Removing Debris from the Cooling System

Service Interval: Before each use or daily (More frequently in dirty operating conditions).

1. Park the machine on a level surface, lower the cutting units, shut off the engine, engage the parking brake, and remove the key.
2. Remove the ball pin from the screen latch (Figure 65)

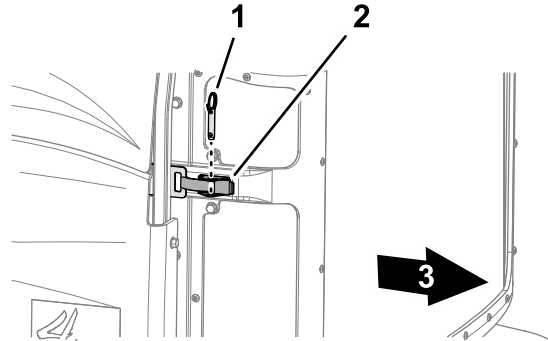

Figure 65

g328488

1. Ball pin
2. Screen latch
3. Back of the machine

3. Unlatch the engine screen, open it, and lift it from the machine (Figure 66).

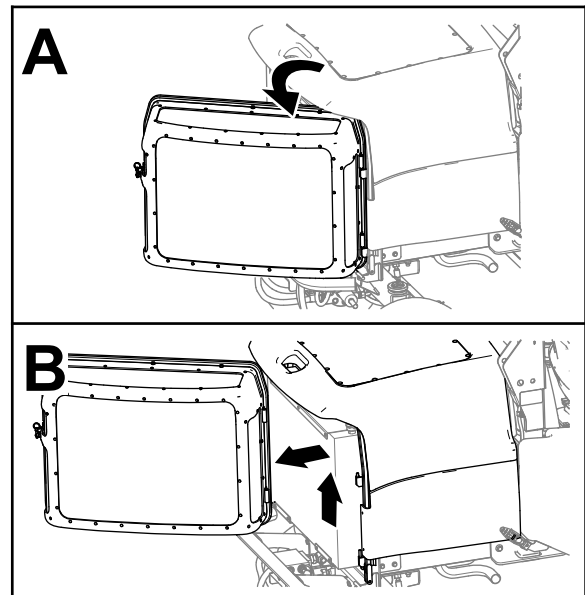

Figure 66

g292487

4. Clean the screens.
5. Unlatch and open the hood (Figure 67).

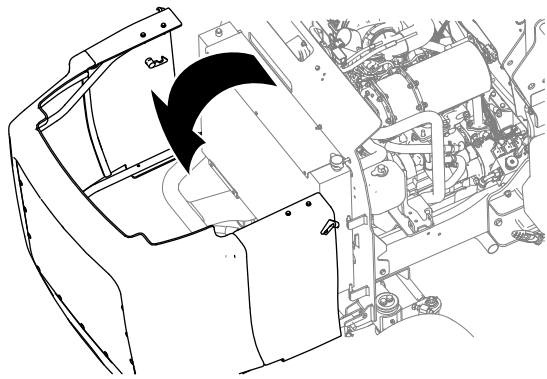

Figure 67

g292486

6. Thoroughly clean all debris out of the engine area.
7. Thoroughly clean both sides of the radiator and oil cooler with compressed air (Figure 68).

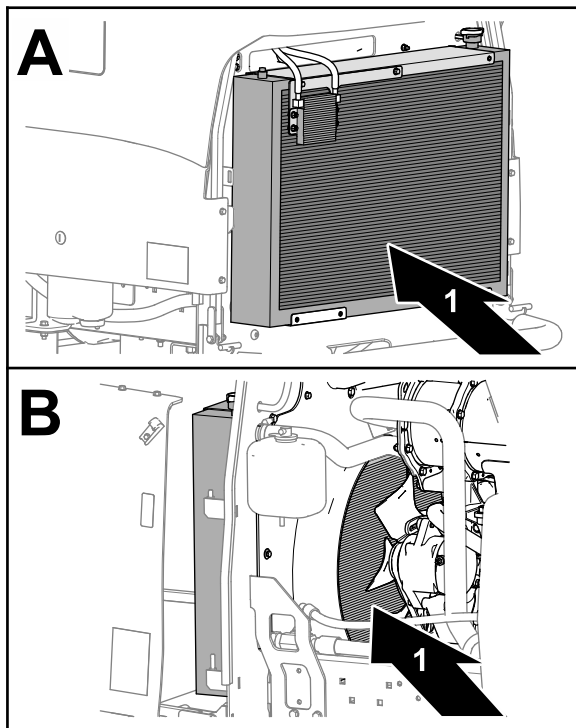

Figure 68

g328487

1. Radiator

8. Close and latch the hood.
9. Assemble the screen onto the pivot pins, close the screen and secure it with the latch and ball pin.

Belt Maintenance

Servicing the Alternator Belt

Service Interval: After the first 50 hours

Every 250 hours

1. Apply 10 kgf (22 lb) of force against the alternator belt (Figure 69), midway between the pulleys.

Note: The belt should deflect 10 mm (3/8 inch).

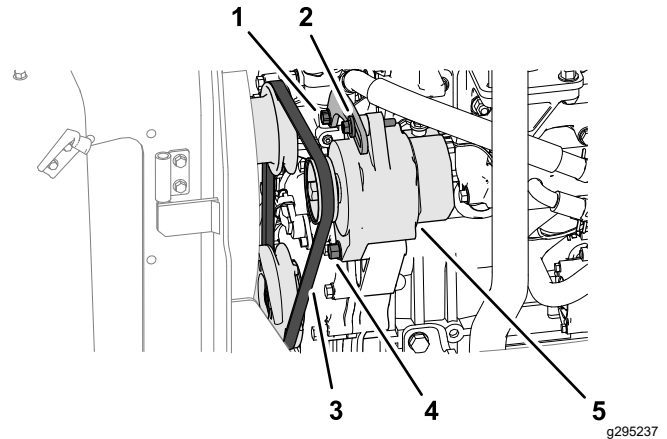

Figure 69

g295237

- | | |
|----------------------------|--------------------------|
| 1. Tension bracket bolt | 4. Alternator pivot bolt |
| 2. Alternator tension bolt | 5. Alternator |
| 3. Belt | |

2. If the belt tension is incorrect, perform the following:
 - If belt deflection is less than 10 mm (3/8 inch), loosen the alternator pivot bolt and tension bolt (Figure 69), and reduce the belt tension.
 - If belt deflection is greater than 10 mm (3/8 inch), loosen the alternator pivot bolt and tension bolt (Figure 69), and increase the belt tension.

Note: If needed, loosen the tension bracket bolt (Figure 69).

3. Tighten the bolts (Figure 69).
4. Check the deflection of the belt again to ensure correct belt tension.

Hydraulic System Maintenance

Hydraulic System Safety

- Seek immediate medical attention if fluid is injected into skin. Injected fluid must be surgically removed within a few hours by a doctor.
- Ensure that all hydraulic-fluid hoses and lines are in good condition and all hydraulic connections and fittings are tight before applying pressure to the hydraulic system.
- Keep your body and hands away from pinhole leaks or nozzles that eject high-pressure hydraulic fluid.
- Use cardboard or paper to find hydraulic leaks.
- Safely relieve all pressure in the hydraulic system before performing any work on the hydraulic system.

Checking the Hydraulic Lines and Hoses

Service Interval: Before each use or daily

Check the hydraulic lines and hoses for leaks, kinked lines, loose mounting supports, wear, loose fittings, weather deterioration, and chemical deterioration. Make all necessary repairs before operating.

Hydraulic Fluid Specifications

The reservoir is filled at the factory with high-quality hydraulic fluid. Check the level of the hydraulic fluid before you first start the engine and daily thereafter; refer to [Checking the Hydraulic Fluid Level \(page 53\)](#).

Recommended hydraulic fluid: Toro PX Extended Life Hydraulic Fluid; available in 19 L (5 US gallon) pails or 208 L (55 US gallon) drums.

Note: A machine using the recommended replacement fluid requires less frequent fluid and filter changes.

Alternative hydraulic fluids: If Toro PX Extended Life Hydraulic Fluid is not available, you may use another conventional, petroleum-based hydraulic fluid having specifications that fall within the listed range for all the following material properties and that it meets industry standards. Do not use synthetic fluid. Consult with your lubricant distributor to identify a satisfactory product.

Note: Toro does not assume responsibility for damage caused by improper substitutions, so use products only from reputable manufacturers who will stand behind their recommendation.

High Viscosity Index/Low Pour Point Anti-wear Hydraulic Fluid, ISO VG 46

Material Properties:

Viscosity, ASTM D445 cSt @ 40°C (104°F)
44 to 48

Viscosity Index ASTM D2270 140 or higher

Pour Point, ASTM D97 -37°C to -45°C (-34°F to -49°F)

Industry Specifications: Eaton Vickers 694 (I-286-S, M-2950-S/35VQ25 or M-2952-S)

Note: Many hydraulic fluids are almost colorless, making it difficult to spot leaks. A red dye additive for the hydraulic fluid is available in 20 ml (0.67 fl oz) bottles. A bottle is sufficient for 15 to 22 L (4 to 6 US gallons) of hydraulic fluid. Order Part No. 44-2500 from your authorized Toro distributor.

Important: Toro Premium Synthetic Biodegradable Hydraulic Fluid is the only synthetic biodegradable fluid approved by Toro. This fluid is compatible with the elastomers used in Toro hydraulic systems and is suitable for a wide-range of temperature conditions. This fluid is compatible with conventional mineral oils, but for maximum biodegradability and performance, the hydraulic system should be thoroughly flushed of conventional fluid. The oil is available in 19 L (5 US gallon) pails or 208 L (55 US gallon) drums from your authorized Toro distributor.

Checking the Hydraulic Fluid Level

Service Interval: Before each use or daily

The reservoir is filled at the factory with high-quality hydraulic fluid. The best time to check the hydraulic fluid is when it is cold.

1. Park the machine on a level surface, lower the cutting units, engage the parking brake, shut off the engine, and remove the key.
2. Check the sight-level gauge on the side of the tank.

Note: The hydraulic-fluid level needs to align with the upper mark.

3. If additional hydraulic fluid is needed, remove the storage compartment; refer to [Removing the Storage Compartment \(page 38\)](#).

- Clean the area around the filler neck and the cap of the hydraulic tank (Figure 70).

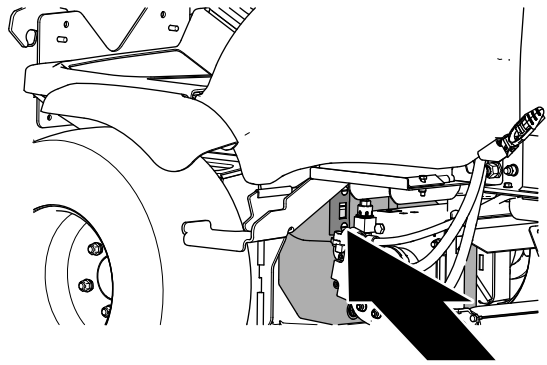

g330122

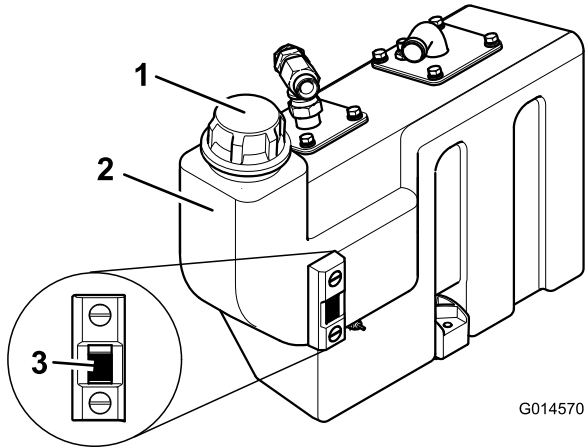

G014570

Figure 70

- Hydraulic-tank cap
- Fluid tank
- Sight-level gauge

- Remove the cap and fill the tank with the specified hydraulic fluid to the upper mark on the sight-level gauge.

Important: Do not overfill the tank with hydraulic fluid.

- Install the cap onto the tank.
- Install the storage compartment; refer to [Installing the Storage Compartment \(page 38\)](#).

Changing the Hydraulic Return Filter

Service Interval: Every 1,000 hours—If you are using the recommended hydraulic fluid, replace the hydraulic filters.

Every 500 hours—If you are not using the recommended hydraulic fluid or have ever filled the reservoir with an alternative fluid, replace the hydraulic filters.

- Park the machine on a level surface, lower the cutting units, shut off the engine, engage the parking brake, and remove the key.
- Open the hood.
- At the left side of the machine, clean the area around the filter head and place a drain pan under the filter (Figure 71).

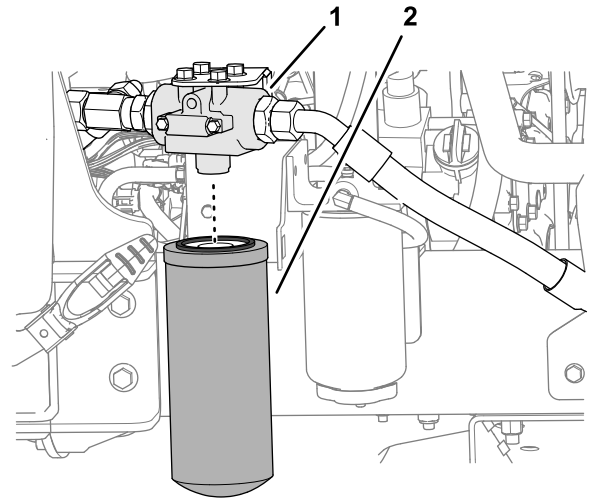

g292490

Figure 71

- Filter head
- Hydraulic fluid return filter

- Remove the return filter (Figure 71).
- Lubricate the gasket of the new return filter with clean hydraulic fluid.
- Assemble the filter to the filter head, and tighten the filter by hand until the gasket contacts the mounting surface, then rotate it an additional 1/2 turn (Figure 71).
- Start the engine and let it run for 2 minutes to purge air from the system.
- Shut off the engine, remove the key, and check for leaks.
- Close and latch the hood.

Changing the Hydraulic Fluid

Service Interval: Every 1,000 hours—If you are using the recommended hydraulic fluid, change the hydraulic fluid.

Every 500 hours—If you are not using the recommended hydraulic fluid or have ever filled the reservoir with an alternative fluid, change the hydraulic fluid.

If the fluid becomes contaminated, contact your authorized Toro distributor to flush the system.

Contaminated fluid looks milky or black when compared to clean fluid.

Draining the Hydraulic Fluid

1. Park the machine on a level surface, lower the cutting units, shut off the engine, engage the parking brake, and remove the key.
2. Remove the storage compartment; refer to [Removing the Storage Compartment \(page 38\)](#).
3. Align a drain pan under the hydraulic tank, remove the tank drain plug, and fully drain the hydraulic fluid ([Figure 72](#)).

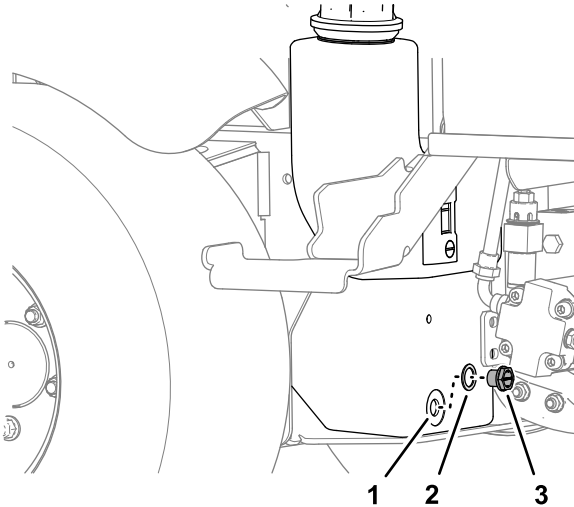

Figure 72

g292488

1. Hydraulic tank
2. Seal
3. Drain plug

4. Install the drain plug with a new seal.

Cleaning the Strainers

1. Remove the oil tank suction flange to gain access to the suction strainer ([Figure 73](#)).

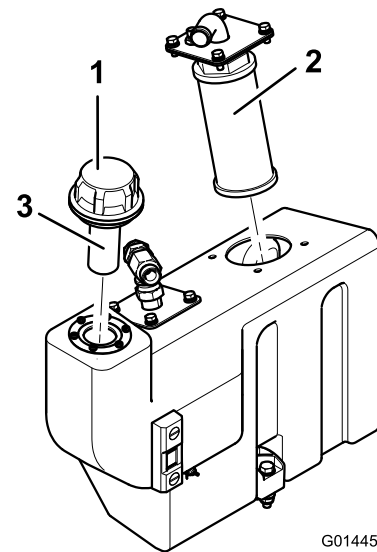

G014452

g014452

Figure 73

1. Oil-tank filler cap
2. Suction strainer
3. Filler strainer

2. Unscrew and remove the strainer and clean with paraffin or petrol before installing ([Figure 73](#)).

Hydraulic Fluid Capacity

32 L (8.5 US gallons); refer to [Hydraulic Fluid Specifications \(page 53\)](#)

Filling the Hydraulic Tank with Fluid

1. Fill the hydraulic tank with the specified hydraulic fluid; refer to [Hydraulic Fluid Specifications \(page 53\)](#) and [Checking the Hydraulic Fluid Level \(page 53\)](#).

Important: Use only hydraulic fluids specified; other hydraulic fluids could damage the system.

2. Run the machine and operate all hydraulic systems until the hydraulic fluid is warm.
3. Check the fluid level and top up as necessary to the upper mark on the sight-level gauge.
4. Install the storage compartment; refer to [Installing the Storage Compartment \(page 38\)](#).

Cutting Unit Maintenance

Blade Safety

A worn or damaged blade or bedknife can break, and a piece could be thrown toward you or bystanders, resulting in serious personal injury or death.

- Inspect the blades and bedknives periodically for excessive wear or damage.
- Use care when checking the blades. Wear gloves and use caution when servicing them. Only replace or backlap the blades and bedknives; never straighten or weld them.
- On machines with multiple cutting units, take care when rotating a cutting unit; it can cause the reels in the other cutting units to rotate.

Backlapping the Cutting Units

▲ WARNING

Contact with the cutting units or other moving parts can result in personal injury.

- Keep fingers, hands, and clothing away from the cutting units or other moving parts.
- Never attempt to turn the cutting units by hand or foot while the engine is running.

Use this process to restore the sharp cutting edges to reels and bedknives which are needed for good-quality grass cutting.

This process can only removes a small amount of metal to restore the cutting edges. If the blade edges are seriously worn or damaged, remove the cutting unit and have the reels and bedknife ground again.

1. Engage the parking brake, lower the cutting units, shut off the engine, and remove the key.
2. Adjust the reels to the bedknives to obtain light contact.
3. Apply a coat of medium-grade detergent-based carborundum paste to the cutting edges of the reels with a long-handled brush.

80-grade carborundum paste	
	Part number
0.45 kg (1 lb)	63-07-088
11.25 kg (25 lb)	63-07-086

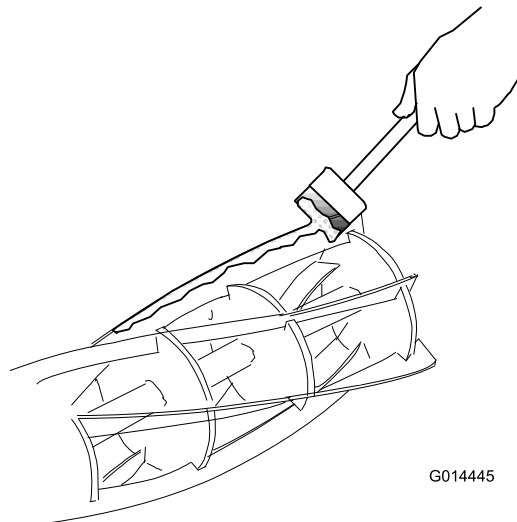

G014445

g014445

Figure 74

4. Sit on the operator seat, start the engine, and set the engine speed to idle.

▲ WARNING

If you touch the cutting units when the engine is running, you could be seriously injured.

- Ensure that the area surrounding the cutting units is clear of people.
 - Keep hands and feet clear of the cutting units during the period when the mower engine is running.
5. Press cutting unit drive switch to the REVERSE (backlap) position for a period of time. Listen to the grinding action.
 6. Operate the cutting unit drive switch to the OFF. When the cutting unit stops running, shut off the engine and remove the key.
 7. Thoroughly clean the blade edges and adjust the bedknives to the reels.
 8. Check that a thin piece of paper can be cut cleanly at all points along the cutting edges while rotating the reels by hand.
 9. If further back lapping is necessary repeat steps 2 through 8.
 10. Thoroughly clean off all traces of the carborundum paste from the reels and bedknives.

Grinding the Cutting Units

- Grind reel blades or bedknives to correct excessively rounded or distorted reel edges or bedknife edges.

Important: Replace the bedknives at the end of their wear life.

- Grind new blades on their holders prior to fitting.
- When grinding reel blades or the bedknives are needed, it is essential that they are ground at the same time.

Note: The only exception to this rule is when a new reel is installed, in which case only grind the bedknife.

- Have your authorized Toro dealer grind your reel blades and bedknives on a quality, well-maintained reel / bedknife grinding machine.

Chassis Maintenance

Inspecting the Seat Belt

Service Interval: Before each use or daily

1. Inspect the seat belt for wear, cuts, and other damage. Replace the seat belt(s) if any component does not operate properly.
2. Clean the seat belt as necessary.

Checking the Fasteners

Service Interval: Before each use or daily

Check the machine for loose and missing fasteners.

Note: Tighten any loose fasteners; replace any missing fasteners.

Extended Maintenance

Service Interval: Every 250 hours—Inspect the cooling-system hoses.

Every 1,500 hours—Flush and replace the coolant.

Every 2 years—Replace all moving hoses.

Every 2 years—Replace the transmission cable.

Cleaning

Washing the Machine

Wash the machine as needed using water alone or with a mild detergent. You may use a rag when washing the machine.

Important: Do not use brackish or reclaimed water to clean the machine.

Important: Do not use power-washing equipment to wash the machine. Power-washing equipment may damage the electrical system, loosen important decals, or wash away necessary grease at friction points. Avoid excessive use of water near the control panel, engine, and battery.

Important: Do not wash the machine with the engine running. Washing the machine with the engine running may result in internal engine damage.

Storage

Storage Safety

- Before you leave the operator's position, do the following:
 - Park the machine on a level surface.
 - Disengage and lower the cutting units.
 - Engage the parking brake.
 - Shut off the engine and remove the key.
 - Wait for all movement to stop.
 - Allow the machine to cool before adjusting, servicing, cleaning, or storing it.
- Do not store the machine or fuel container where there is an open flame, spark, or pilot light, such as on a water heater or other appliance.

Preparing the Traction Unit

1. Park the machine on a level surface, lower the cutting units, engage the parking brake, shut off the engine, and remove the key.
2. Thoroughly clean the traction unit, cutting units, and the engine.
3. Check the tire pressure; refer to [Checking the Tire Air Pressure \(page 48\)](#).
4. Check all fasteners for looseness; tighten them as necessary.
5. Grease or oil all grease fittings and pivot points. Wipe up any excess lubricant.
6. Lightly sand and use touch-up paint on painted areas that are scratched, chipped, or rusted. Repair any dents in the metal body.

Preparing the Engine

1. Drain the oil from the engine and install the drain plug.
2. Remove and discard the oil filter. Install a new oil filter.
3. Fill the engine with specified motor oil.
4. Start the engine and run it at idle speed for approximately 2 minutes.
5. Shut off the engine and remove the key.
6. Flush the fuel tank with fresh, clean fuel.
7. Secure all fuel-system fittings.
8. Thoroughly clean and service the air-cleaner assembly.
9. Seal the air-cleaner inlet and the exhaust outlet with weatherproof tape.
10. Check the antifreeze protection and add a 50/50 solution of water and ethylene glycol antifreeze as needed for the expected minimum temperature in your area.

Preparing the Electrical System

1. Service the battery and cables as follows; refer to [Electrical System Safety \(page 47\)](#).
2. Remove the battery terminals from the battery posts.
3. Clean the battery, terminals, and posts with a wire brush and baking-soda solution.
4. Coat the cable terminals and battery posts with Grafo 112X skin-over grease (Toro Part No. 505-47) or petroleum jelly to prevent corrosion.
5. Slowly charge the battery every 60 days for 24 hours to prevent lead sulfation of the battery.

Troubleshooting

Problem	Possible Cause	Corrective Action
There are areas of uncut grass at the overlap between cutting units.	<ol style="list-style-type: none"> 1. You are turning too tightly. 2. The machine slides sideways when driving the machine across the face of a slope. 3. There is no ground contact on 1 end of the cutting unit because of poorly routed hoses or wrongly positioned hydraulic adapters. 4. There is no ground contact on 1 end of the cutting unit because a pivot pin is seizing. 5. There is no ground contact on 1 end of the cutting unit because of grass buildup under the cutting unit. 	<ol style="list-style-type: none"> 1. Increase the turning radius. 2. Mow up/down the slope. 3. Correct the hose routing or the position of the hydraulic adapters. 4. Release and grease the pivot points. 5. Clear the grass buildup.
There are full-width ridge lines in the cut across the direction of travel.	<ol style="list-style-type: none"> 1. The forward speed is too high. 2. The reel speed is too slow. 3. The height of cut is too low. 	<ol style="list-style-type: none"> 1. Reduce forward speed. 2. Increase engine speed. 3. Raise the height of cut.
There are ridge lines in the cut grass, across the direction of travel, over the cutting width of 1 cutting unit.	<ol style="list-style-type: none"> 1. A reel is running slow. 	<ol style="list-style-type: none"> 1. Check the reel speed; consult your authorized distributor.
There is a step in the cut grass height at the point of overlap between cutting units.	<ol style="list-style-type: none"> 1. There is an inconsistent height-of-cut setting on 1 cutting unit. 2. The raise/lower position control is not in the float position. 3. There is no ground contact on 1 end of the cutting unit because of poorly routed hoses or wrongly positioned hydraulic adapters. 4. There is no ground contact on 1 end of the cutting unit because of pivot pins seizing. 5. There is no ground contact on 1 end of the cutting unit because of grass buildup under the cutting unit. 	<ol style="list-style-type: none"> 1. Check and adjust the height-of-cut setting. 2. Set the position control to the float position. 3. Correct the hose routing and the position of the hydraulic adapters. 4. Release and grease the pivot points. 5. Remove the grass buildup.
There are some uncut or poorly cut strands of grass.	<ol style="list-style-type: none"> 1. A reel is partially out of contact with the bedknife. 2. A reel is in heavy contact with the bedknife. 3. The height of cut is too high. 4. The cutting edges of the reels/bedknives are rounded. 	<ol style="list-style-type: none"> 1. Adjust the reel-to-bedknife contact. 2. Adjust the reel-to-bedknife contact. 3. Lower the height of cut. 4. Back lap or grind the edges.
There are lines of uncut or badly cut grass in the direction of travel.	<ol style="list-style-type: none"> 1. There is tram lining of the cutting edges due to heavy contact caused by poor reel-to-bedknife adjustment. 2. The bedknife is in contact with the ground. 3. The bedknife has a nose-down angle. 4. The cutting units are bouncing. 5. There are worn reel bearings/bearing housing pivots. 6. There are loose components in the cutting unit. 	<ol style="list-style-type: none"> 1. Back lap or grind the edges. 2. Raise the height of cut. 3. Adjust the cutting unit to position the bedknife parallel to the ground. 4. Reduce the forward speed and reduce the weight transfer. 5. Replace any worn parts. 6. Check and tighten components as necessary.

Problem	Possible Cause	Corrective Action
There is scalping of the turf.	<ol style="list-style-type: none"> 1. The undulations are too severe for the height of cut setting. 2. The height of cut is too low. 	<ol style="list-style-type: none"> 1. Use floating cutting units. 2. Raise the height of cut.
There is excessive bedknife wear.	<ol style="list-style-type: none"> 1. The bedknife is in heavy contact with the ground. 2. The cutting edges of the reel and/or bedknife are rounded. 3. The reel is in heavy contact with the bedknife. 4. There is a damaged reel or bedknife. 5. There are excessively abrasive ground conditions. 	<ol style="list-style-type: none"> 1. Raise the height of cut. 2. Back lap or grind the edges. 3. Adjust the reel-to-bedknife contact. 4. Grind or replace parts as necessary. 5. Raise the height of cut.
The engine does not start with the ignition key.	<ol style="list-style-type: none"> 1. The transmission neutral interlock switch is not energized. 2. The parking brake interlock switch is not energized. 3. The cutting unit drive interlock switch is not energized. 4. There is a malfunctioning electrical connection. 	<ol style="list-style-type: none"> 1. Remove your foot from the forward/reverse pedals or check the setting of the transmission neutral interlock switch. 2. Move the parking brake switch to the on position. 3. Move the cutting unit switch to the off position. 4. Locate and correct the fault in the electrical system.
The battery has no power.	<ol style="list-style-type: none"> 1. A terminal connection is loose or corroded. 2. The alternator belt is loose or worn. 3. The battery is discharged. 4. There is an electrical short circuit. 	<ol style="list-style-type: none"> 1. Clean and tighten the terminal connections. Charge the battery. 2. Adjust the tension or replace the belt; refer to engine owner's manual. 3. Charge or replace the battery. 4. Locate the short circuit and fix it.
The hydraulic fluid is overheating.	<ol style="list-style-type: none"> 1. There is a blocked screen. 2. The fluid cooler fins are dirty/blocked. 3. The engine radiator is dirty/blocked. 4. The relief valve setting is low. 5. The fluid level is low. 6. The brakes are engaged. 7. The reels are tight on the bedknives. 8. There is a malfunctioning fan or fan drive. 	<ol style="list-style-type: none"> 1. Clean the screen. 2. Clean the fins. 3. Clean the radiator. 4. Have the relief valve pressure checked. Consult your authorized distributor. 5. Fill the reservoir to the correct level. 6. Disengage the brakes. 7. Adjust the settings. 8. Check the fan operation and service it as required.
The brake system does not operate correctly.	<ol style="list-style-type: none"> 1. There is a malfunctioning wheel motor brake assembly. 2. The brake discs are worn. 	<ol style="list-style-type: none"> 1. Consult your authorized distributor. 2. Replace the brake discs; consult your authorized distributor.
There is a lack of steering.	<ol style="list-style-type: none"> 1. The steering valve is malfunctioning. 2. A hydraulic cylinder is malfunctioning. 3. A steering hose is damaged. 	<ol style="list-style-type: none"> 1. Service or replace the steering valve. 2. Service or replace the hydraulic cylinder. 3. Replace the hose.

Problem	Possible Cause	Corrective Action
There is no machine movement in forward or reverse.	<ol style="list-style-type: none"> 1. The parking brake is engaged. 2. The fluid level is low. 3. The reservoir has the wrong kind of fluid. 4. The drive pedal linkage is damaged. 5. The transmission pump is damaged. 6. The transmission bypass valve is open. 7. There is a broken drive coupling. 	<ol style="list-style-type: none"> 1. Disengage the parking brake. 2. Fill the reservoir to the correct level. 3. Drain the reservoir and fill it with the correct fluid. 4. Check the linkage and replace any damaged or worn parts. 5. Have the transmission pump overhauled by your authorized distributor. 6. Close the bypass valve. 7. Replace the drive coupling.
The machine creeps forward or backward in neutral.	<ol style="list-style-type: none"> 1. The transmission neutral adjustment is set incorrectly. 	<ol style="list-style-type: none"> 1. Adjust the transmission neutral linkage setting.
There is excessive noise in the hydraulic system.	<ol style="list-style-type: none"> 1. A pump is malfunctioning. 2. A motor is malfunctioning. 3. Air is leaking into the system. 4. A suction strainer is blocked or damaged. 5. The fluid has excessive viscosity due to cold conditions. 6. The relief valve setting is low. 7. The hydraulic fluid level is low. 	<ol style="list-style-type: none"> 1. Identify the noisy pump and service or replace it. 2. Identify the noisy motor and service or replace it. 3. Tighten or replace the hydraulic fittings, particularly in the suction lines. 4. Clean and replace the suction strainer or renew it as necessary. 5. Allow the system to warm up. 6. Have the relief valve pressure checked. Consult your authorized distributor. 7. Fill the hydraulic fluid reservoir to the correct level.
After an initial period of satisfactory operation, the machine loses power.	<ol style="list-style-type: none"> 1. A pump or motor is worn. 2. The hydraulic fluid level is low. 3. The fluid in the hydraulic system has the wrong viscosity. 4. The fluid-filter element is blocked. 5. The pressure relief valve is malfunctioning. 6. The system is overheating. 7. There are leaks on the suction hose. 	<ol style="list-style-type: none"> 1. Replace parts as necessary. 2. Fill hydraulic fluid tank to the correct level. 3. Replace the fluid in the hydraulic tank with the correct viscosity-grade fluid; refer to the Specifications section. 4. Change the filter element. 5. Have the relief valve cleaned and pressure checked. Consult your authorized distributor. 6. Check the reel-to-bedknife adjustment. Reduce the work rate (increase the height of cut or reduce the forward speed). 7. Check and tighten the fittings. Replace the hose if necessary.
A reel 'knocks' while rotating.	<ol style="list-style-type: none"> 1. There is a high spot on the reel or the bedknife due to contact with a foreign object. 2. The reel bearings are worn. 	<ol style="list-style-type: none"> 1. Remove the high spot with a stone and back lap to restore the cutting edges. Severe damage will require grinding. 2. Replace the bearings as necessary.
1 reel rotates slowly.	<ol style="list-style-type: none"> 1. A reel bearing is seized. 2. A motor with incorrect rotation was installed. 3. The integral relief valves of the motor are jammed open. 4. The reel is tight on the bedknife. 5. The motor is worn. 	<ol style="list-style-type: none"> 1. Replace the bearings as necessary. 2. Check the motor and replace it if necessary. 3. Have the relief valves cleaned and checked. 4. Adjust the setting. 5. Replace the motor.

Problem	Possible Cause	Corrective Action
A cutting unit fails to lift out of work.	<ol style="list-style-type: none"> 1. There is a lift cylinder seal failure. 2. The pressure relief valve is jammed open or wrongly set. 3. There is a malfunctioning control valve. 4. There is mechanical blockage. 	<ol style="list-style-type: none"> 1. Replace the seals. 2. Have the relief valve pressure checked. Consult your authorized distributor. 3. Overhaul the control valve. 4. Remove the blockage.
The cutting units do not follow the contours of the ground.	<ol style="list-style-type: none"> 1. The hose routing or the orientation of the hydraulic fittings is incorrect. 2. The pivot points are too tight. 3. The cutting unit operating in the 'hold' position. 4. The weight transfer is set too high. 	<ol style="list-style-type: none"> 1. Move the cutting units throughout the extremes of movement and observe any tightness in the hoses. Correctly route the hoses and orientate the fittings as necessary. 2. Release and grease the pivot point as necessary. 3. Move the position control switch to 'down / float' position. 4. Reduce the weight transfer.
The cutting units fail to start up when lowered into work.	<ol style="list-style-type: none"> 1. The seat sensor switch is malfunctioning. 2. The hydraulic-fluid level is low. 3. A driveshaft is sheared. 4. The pressure relief valve is jammed open or wrongly set. 5. A cutting unit is jammed. 6. A reel is tight on the bedknife. 7. A cutting unit control valve is in the 'off' position, caused by malfunctioning control valve. 8. A cutting unit control valve is in the 'off' position, caused by an electrical fault. 9. The lift arm proximity switch is incorrectly set. 	<ol style="list-style-type: none"> 1. Check the mechanical and electrical operation of the switch. 2. Fill the hydraulic-fluid reservoir to the correct level. 3. Check the motor and reel driveshafts and replace them if necessary. 4. Have the relief valve pressure checked. Consult your authorized dealer. 5. Clear any jams as necessary. 6. Adjust the setting. 7. Overhaul the control valve. 8. Have the electrical system checked for an electrical fault. 9. Check and adjust the proximity switch.
The reels rotate in the wrong direction.	<ol style="list-style-type: none"> 1. The hoses are connected wrongly. 2. The cutting unit drive switch is connected wrongly. 	<ol style="list-style-type: none"> 1. Check the hydraulic circuit and connect the hoses correctly. 2. Check the electrical connections of the switch.

Notes:

Notes:

EEA/UK Privacy Notice

Toro's Use of Your Personal Information

The Toro Company ("Toro") respects your privacy. When you purchase our products, we may collect certain personal information about you, either directly from you or through your local Toro company or dealer. Toro uses this information to fulfil contractual obligations - such as to register your warranty, process your warranty claim or to contact you in the event of a product recall - and for legitimate business purposes - such as to gauge customer satisfaction, improve our products or provide you with product information which may be of interest. Toro may share your information with our subsidiaries, affiliates, dealers or other business partners in connection these activities. We may also disclose personal information when required by law or in connection with the sale, purchase or merger of a business. We will never sell your personal information to any other company for marketing purposes.

Retention of your Personal Information

Toro will keep your personal information as long as it is relevant for the above purposes and in accordance with legal requirements. For more information about applicable retention periods please contact legal@toro.com.

Toro's Commitment to Security

Your personal information may be processed in the US or another country which may have less strict data protection laws than your country of residence. Whenever we transfer your information outside of your country of residence, we will take legally required steps to ensure that appropriate safeguards are in place to protect your information and to make sure it is treated securely.

Access and Correction

You may have the right to correct or review your personal data, or object to or restrict the processing of your data. To do so, please contact us by email at legal@toro.com. If you have concerns about the way in which Toro has handled your information, we encourage you to raise this directly with us. Please note that European residents have the right to complain to your Data Protection Authority.



The Toro Warranty

Two-Year or 1,500 Hours Limited Warranty

Conditions and Products Covered

The Toro Company warrants your Toro Commercial product ("Product") to be free from defects in materials or workmanship for 2 years or 1,500 operational hours*, whichever occurs first. This warranty is applicable to all products with the exception of Aerators (refer to separate warranty statements for these products). Where a warrantable condition exists, we will repair the Product at no cost to you including diagnostics, labor, parts, and transportation. This warranty begins on the date the Product is delivered to the original retail purchaser.

* Product equipped with an hour meter.

Instructions for Obtaining Warranty Service

You are responsible for notifying the Commercial Products Distributor or Authorized Commercial Products Dealer from whom you purchased the Product as soon as you believe a warrantable condition exists. If you need help locating a Commercial Products Distributor or Authorized Dealer, or if you have questions regarding your warranty rights or responsibilities, you may contact us at:

Toro Commercial Products Service Department
8111 Lyndale Avenue South
Bloomington, MN 55420-1196

952-888-8801 or 800-952-2740
E-mail: commercial.warranty@toro.com

Owner Responsibilities

As the product owner, you are responsible for required maintenance and adjustments stated in your *Operator's Manual*. Repairs for product issues caused by failure to perform required maintenance and adjustments are not covered under this warranty.

Items and Conditions Not Covered

Not all product failures or malfunctions that occur during the warranty period are defects in materials or workmanship. This warranty does not cover the following:

- Product failures which result from the use of non-Toro replacement parts, or from installation and use of add-on, or modified non-Toro branded accessories and products.
- Product failures which result from failure to perform recommended maintenance and/or adjustments.
- Product failures which result from operating the Product in an abusive, negligent, or reckless manner.
- Parts consumed through use that are not defective. Examples of parts which are consumed, or used up, during normal Product operation include, but are not limited to, brake pads and linings, clutch linings, blades, reels, rollers and bearings (sealed or greasable), bed knives, spark plugs, castor wheels and bearings, tires, filters, belts, and certain sprayer components such as diaphragms, nozzles, flow meters, and check valves.
- Failures caused by outside influence, including, but not limited to, weather, storage practices, contamination, use of unapproved fuels, coolants, lubricants, additives, fertilizers, water, or chemicals.
- Failure or performance issues due to the use of fuels (e.g. gasoline, diesel, or biodiesel) that do not conform to their respective industry standards.
- Normal noise, vibration, wear and tear, and deterioration. Normal "wear and tear" includes, but is not limited to, damage to seats due to wear or abrasion, worn painted surfaces, scratched decals or windows.

Countries Other than the United States or Canada

Customers who have purchased Toro products exported from the United States or Canada should contact their Toro Distributor (Dealer) to obtain guarantee policies for your country, province, or state. If for any reason you are dissatisfied with your Distributor's service or have difficulty obtaining guarantee information, contact your Authorized Toro Service Center.

Parts

Parts scheduled for replacement as required maintenance are warranted for the period of time up to the scheduled replacement time for that part. Parts replaced under this warranty are covered for the duration of the original product warranty and become the property of Toro. Toro will make the final decision whether to repair any existing part or assembly or replace it. Toro may use remanufactured parts for warranty repairs.

Deep Cycle and Lithium-Ion Battery Warranty

Deep cycle and Lithium-Ion batteries have a specified total number of kilowatt-hours they can deliver during their lifetime. Operating, recharging, and maintenance techniques can extend or reduce total battery life. As the batteries in this product are consumed, the amount of useful work between charging intervals will slowly decrease until the battery is completely worn out. Replacement of worn out batteries, due to normal consumption, is the responsibility of the product owner. Note: (Lithium-Ion battery only): Refer to the battery warranty for additional information.

Lifetime Crankshaft Warranty (ProStripe 02657 Model Only)

The ProStripe which is fitted with a genuine Toro Friction Disc and Crank-Safe Blade Brake Clutch (integrated Blade Brake Clutch (BBC) + Friction Disc assembly) as original equipment and used by the original purchaser in accordance with recommended operating and maintenance procedures, are covered by a Lifetime Warranty against engine crankshaft bending. Machines fitted with friction washers, Blade Brake Clutch (BBC) units and other such devices are not covered by the Lifetime Crankshaft Warranty.

Maintenance is at Owner's Expense

Engine tune-up, lubrication, cleaning and polishing, replacement of filters, coolant, and completing recommended maintenance are some of the normal services Toro products require that are at the owner's expense.

General Conditions

Repair by an Authorized Toro Distributor or Dealer is your sole remedy under this warranty.

The Toro Company is not liable for indirect, incidental or consequential damages in connection with the use of the Toro Products covered by this warranty, including any cost or expense of providing substitute equipment or service during reasonable periods of malfunction or non-use pending completion of repairs under this warranty. Except for the Emissions warranty referenced below, if applicable, there is no other express warranty. All implied warranties of merchantability and fitness for use are limited to the duration of this express warranty.

Some states do not allow exclusions of incidental or consequential damages, or limitations on how long an implied warranty lasts, so the above exclusions and limitations may not apply to you. This warranty gives you specific legal rights, and you may also have other rights which vary from state to state.

Note Regarding Emissions Warranty

The Emissions Control System on your Product may be covered by a separate warranty meeting requirements established by the U.S. Environmental Protection Agency (EPA) and/or the California Air Resources Board (CARB). The hour limitations set forth above do not apply to the Emissions Control System Warranty. Refer to the Engine Emission Control Warranty Statement supplied with your product or contained in the engine manufacturer's documentation.



Count on it.