



**Count on it.**

**Operator's Manual**

# Flex-Force Power System™ 60V MAX Axial Blower

Model No. 51824—Serial No. 323000001 and Up

Model No. 51824T—Serial No. 323000001 and Up

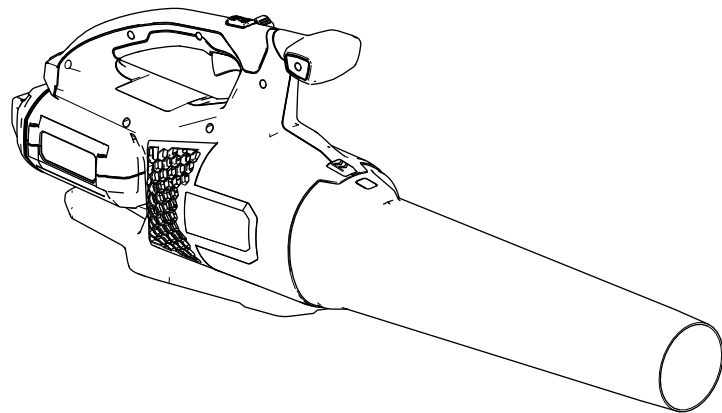

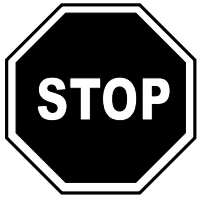

**For assistance, please see [www.Toro.com/support](http://www.Toro.com/support) for instructional videos or contact 1-888-384-9939 before returning this product.**

**⚠ WARNING**

**CALIFORNIA  
Proposition 65 Warning**

**The power cord on this product contains lead, a chemical known to the State of California to cause birth defects or other reproductive harm. Wash hands after handling.**

**Use of this product may cause exposure to chemicals known to the State of California to cause cancer, birth defects, or other reproductive harm.**

Whenever you need service, genuine Toro parts, or additional information, contact an Authorized Service Dealer or Toro Customer Service and have the model and serial numbers of your product ready. [Figure 1](#) identifies the location of the model and serial numbers on the product. Write the numbers in the space provided.

**Important:** With your mobile device, you can scan the QR code (if equipped) on the serial number plate to access warranty, parts, and other product information.

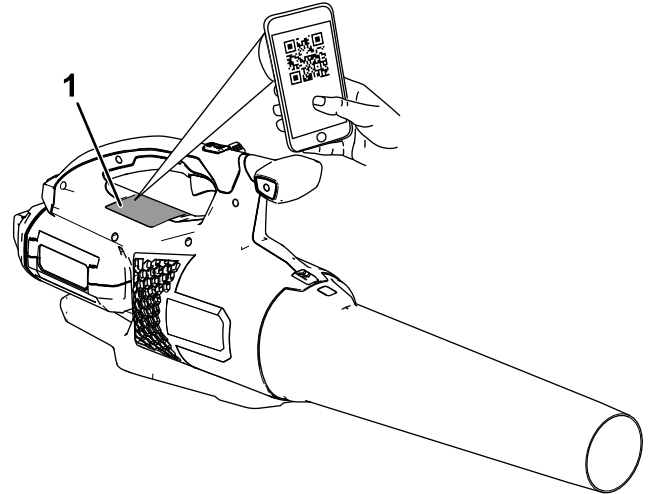

g426535

**Figure 1**

1. Model and serial number location.

**Model No.** \_\_\_\_\_

**Serial No.** \_\_\_\_\_

# Introduction

This blower is intended to be used by residential homeowners to move leaf-like debris as needed outdoors. It is designed to use Toro 60V lithium-ion battery packs. These battery packs are designed to be charged only by Toro 60V lithium-ion battery chargers. Using these products for purposes other than their intended use could prove dangerous to you and bystanders.

**Model 51824T does not include a battery or a charger.**

Read this information carefully to learn how to operate and maintain your product properly and to avoid injury and product damage. You are responsible for operating the product properly and safely.

Visit [www.Toro.com](http://www.Toro.com) for more information, including safety tips, training materials, accessory information, help finding a dealer, or to register your product.

# Safety-Alert Symbol

The safety-alert symbol (Figure 2) shown in this manual and on the machine identifies important safety messages that you must follow to prevent accidents.



Figure 2  
Safety-alert symbol

g000502

The safety-alert symbol appears above information that alerts you to unsafe actions or situations and is followed by the word **DANGER**, **WARNING**, or **CAUTION**.

**DANGER** indicates an imminently hazardous situation which, if not avoided, **will** result in death or serious injury.

**WARNING** indicates a potentially hazardous situation which, if not avoided, **could** result in death or serious injury.

**CAUTION** indicates a potentially hazardous situation which, if not avoided, **may** result in minor or moderate injury.

This manual uses two other words to highlight information. **Important** calls attention to special mechanical information and **Note** emphasizes general information worthy of special attention.

# Safety

## IMPORTANT SAFETY INSTRUCTIONS

### **⚠ WARNING**

When using electric gardening tools, always read and follow basic safety warnings and instructions to reduce the risk of fire, electric shock, and personal injury, including the following:

## Read All Instructions

### I. Training

1. The operator of the tool is responsible for any accidents or hazards occurring to others or their property.
2. Do not allow children to use or play with the tool, battery pack, or the battery charger; local regulations may restrict the age of the operator.
3. Do not allow children or untrained people to operate or service this device. Allow only people who are responsible, trained, familiar with the instructions, and physically capable to operate or service the device.
4. Before using the tool, battery pack, and battery charger, read all the instructions and cautionary markings on these products.
5. Become familiar with the controls and proper use of the tool, battery pack, and battery charger.

### II. Preparation

1. Keep bystanders and children away from the operating area.
2. Use only the battery pack specified by Toro. Using other accessories and attachments may increase the risk of injury and fire.
3. Plugging the battery charger into an outlet that is not 120 V can cause a fire or electric shock. Do not plug the battery charger into an outlet other than 120 V. For a different style of connection, use an attachment plug adapter of the proper configuration for the power outlet if needed.
4. Do not use a damaged or modified battery pack or battery charger, which may exhibit unpredictable behavior that results in fire, explosion, or risk of injury.
5. If the supply cord to the battery charger is damaged, contact an Authorized Service Dealer to replace it.
6. Charge the battery pack with only the battery charger specified by Toro. A charger suitable for

- one type of battery pack may create a risk of fire when used with another battery pack.
7. Charge the battery pack in a well-ventilated area only.
  8. Follow all charging instructions and do not charge the battery pack outside of the temperature range specified in the instructions. Otherwise, you may damage the battery pack and increase the risk of fire.
  9. Do not operate the tool without all guards and other safety protective devices in place and functioning properly on the tool.
  10. Dress properly—Wear appropriate clothing, including eye protection; long pants; substantial, slip-resistant footwear; and hearing protection. Tie back long hair and do not wear loose clothing or loose jewelry that can get caught in moving parts. Wear a dust mask in dusty operating conditions.
  12. Ensure that the ventilation openings are kept clear of debris.
  13. Do not insert any object into the opening or use the tool with a blocked opening. Keep the opening free from dust, lint, hair, or anything else that could reduce the air flow.
  14. Use extra care when using the tool to clean stairways.
  15. Under abusive conditions, the battery pack may eject liquid; avoid contact. If you accidentally come into contact with the liquid, flush with water. If the liquid contacts your eyes, seek medical help. Liquid ejected from the battery pack may cause irritation or burns.
  16. Do not expose a battery pack or tool to fire or excessive temperature. Exposure to fire or temperature above 130°C (265°F) may cause explosion.

### III. Operation

1. Avoid dangerous environments—Do not use the tool in rain or in damp or wet locations.
2. Use the proper tool for your application—Using the tool for purposes other than its intended use could prove dangerous to you and bystanders.
3. Prevent unintentional starting—Ensure that the switch is in the OFF position before connecting to the battery pack and handling the tool. Do not carry the tool with your finger on the switch or energize the tool with the switch in the ON position.
4. Operate the tool only in daylight or good artificial light.
5. Remove the battery pack from the tool before adjusting it or changing accessories.
6. Keep your hands and feet away from the opening and all moving parts.
7. Stop the tool, remove the battery pack from the tool, and wait for all movement to stop before adjusting, servicing, cleaning, or storing the tool.
8. Remove the battery pack from the tool whenever you leave it unattended.
9. Do not force the tool—Allow the tool to do the job better and safer at the rate for which it was designed.
10. Do not overreach—Keep proper footing and balance at all times, especially on slopes. Walk, never run with the tool.
11. Stay alert—Watch what you are doing and use common sense when operating the tool. Do not use the tool while ill, tired, or under the influence of alcohol or drugs.
17. CAUTION—A mistreated battery pack may present a risk of fire, explosion, or chemical burn.
  - Do not disassemble the battery pack.
  - Replace the battery pack with a genuine Toro battery pack only; using another type of battery pack may cause a fire or risk of injury.
  - Keep battery packs out of the reach of children and in the original packaging until you are ready to use them.

#### **IV. Maintenance and Storage**

1. Maintain the tool with care—Keep it clean and in good repair for best performance and to reduce the risk of injury. Follow the instructions for lubricating and changing accessories. Keep handles dry, clean, and free from oil and grease.
2. When the battery pack is not in use, keep it away from metal objects such as paper clips, coins, keys, nails, and screws that can make a connection from one terminal to another. Shorting the battery terminals may cause burns or a fire.
3. Keep your hands and feet away from moving parts.
4. Stop the tool, remove the battery pack from the tool, and wait for all movement to stop before adjusting, servicing, cleaning, or storing the tool.
5. Check the tool for damaged parts—If there are damaged guards or other parts, determine whether it will operate properly. Check for misaligned and binding moving parts, broken parts, mounting, and any other condition that may affect its operation. Unless indicated in the instructions, have an Authorized Service Dealer repair or replace a damaged guard or part.
6. Keep all fasteners on the tool tight.
7. Do not attempt to service or repair the tool, battery pack, or battery charger except as indicated in the instructions. Have an Authorized Service Dealer perform service using identical replacement parts to ensure that the product is safely maintained.
8. Store an idle tool indoors in a place that is dry, secure, and out of the reach of children.

**SAVE THESE  
INSTRUCTIONS**

# Safety and Instructional Decals



Safety decals and instructions are easily visible to the operator and are located near any area of potential danger. Replace any decal that is damaged or missing.

**WARNING** To reduce risk of injury to persons, remove battery pack when not in use. For household use only. Store indoors. For use with approved TORO 60V accessories, batteries & charger models.

**AVERTISSEMENT** Pour réduire les risques de blessures corporelles, retirez la batterie quand vous ne l'utilisez pas. Réservez à usage domestique. Remisez à l'intérieur. À utiliser avec les accessoires, batteries et modèles de chargeurs TORO 60V approuvés.

**ADVERTENCIA** Para reducir el riesgo de lesiones a personas, retire la batería cuando no esté en uso. Únicamente para uso doméstico. Almacenar en espacios interiores. Para su uso con modelos aprobados de baterías y cargadores TORO de 60 V.

**WARNING: Cancer and Reproductive Harm** - www.P65Warnings.ca.gov. For more information, please visit www.ttcocaprop65.com

**AVERTISSEMENT: Cancer et Troubles de l'appareil reproducteur** - www.P65Warnings.ca.gov. Pour plus d'informations, veuillez visiter www.toro.com/CAProp65

**ADVERTENCIA: Cáncer y Daño Reproductivo** - www.P65Warnings.ca.gov. Para obtener más información, visite www.toro.com/CAProp65

**60V MAX\* DC BLOWER / VENTILATEUR / SOPLADOR**  
 \*60VDC MAXIMUM / 54VDC NOMINAL THE TORO COMPANY  
 \*60 VDC MAXIMUM / 54 VDC NOMINALE 8111 Lyndale Avenue South  
 \*60 VDC MÁXIMA / 54 VDC NOMINAL Bloomington, MN 55420-1196 USA

PATENT: www.ttcopats.com Conforms to / Conforme à la norme / Cumple la norma UL STD 1017  
 Country of Origin: Vietnam Certified to / Certifié / Homologada según CSA STD C22.2 1243 Intertek 50189666

Model: 51824  
 Modèle / Modelo: 51824  
 Date Code:   
 Code de date / Código de fecha:   
 Serial Number:   
 Numéro de série / Número de Serie:

139-5358

decal139-5358

**WARNING** To reduce risk of injury to persons, remove battery pack when not in use. For household use only. Store indoors. For use with approved TORO 60V accessories, batteries & charger models.

**AVERTISSEMENT** Pour réduire les risques de blessures corporelles, retirez la batterie quand vous ne l'utilisez pas. Réservez à usage domestique. Remisez à l'intérieur. À utiliser avec les accessoires, batteries et modèles de chargeurs TORO 60V approuvés.

**ADVERTENCIA** Para reducir el riesgo de lesiones a personas, retire la batería cuando no esté en uso. Únicamente para uso doméstico. Almacenar en espacios interiores. Para su uso con modelos aprobados de baterías y cargadores TORO de 60 V.

**WARNING: Cancer and Reproductive Harm** - www.P65Warnings.ca.gov. For more information, please visit www.ttcocaprop65.com

**AVERTISSEMENT: Cancer et Troubles de l'appareil reproducteur** - www.P65Warnings.ca.gov. Pour plus d'informations, veuillez visiter www.toro.com/CAProp65

**ADVERTENCIA: Cáncer y Daño Reproductivo** - www.P65Warnings.ca.gov. Para obtener más información, visite www.toro.com/CAProp65

**60V MAX\* DC BLOWER / VENTILATEUR / SOPLADOR**  
 \*60VDC MAXIMUM / 54VDC NOMINAL THE TORO COMPANY  
 \*60 VDC MAXIMUM / 54 VDC NOMINALE 8111 Lyndale Avenue South  
 \*60 VDC MÁXIMA / 54 VDC NOMINAL Bloomington, MN 55420-1196 USA

PATENT: www.ttcopats.com Conforms to / Conforme à la norme / Cumple la norma UL STD 1017  
 Country of Origin: Vietnam Certified to / Certifié / Homologada según CSA STD C22.2 1243 Intertek 50189666

Model: 51824T  
 Modèle / Modelo: 51824T  
 Date Code:   
 Code de date / Código de fecha:   
 Serial Number:   
 Numéro de série / Número de Serie:

139-5359

decal139-5359

1. Warning—read the *Operator's Manual*; stay away from moving parts; keep all guards and shields in place; wear eye protection; do not expose to rain.
2. Warning—keep bystanders away from the machine in all directions.
3. Thrown object hazard—keep bystanders away.

1. Warning—read the *Operator's Manual*; stay away from moving parts; keep all guards and shields in place; wear eye protection; do not expose to rain.
2. Warning—keep bystanders away from the machine in all directions.
3. Thrown object hazard—keep bystanders away.



140-8475

1. Read the *Operator's Manual*.
2. Call 2Recycle® battery recycling program
3. Keep away from open fire or flames.
4. Do not expose to rain.

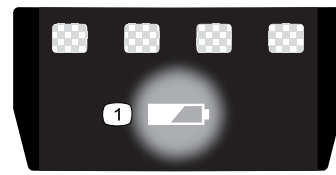

137-9461

1. Battery charge status

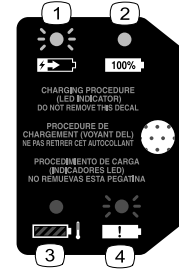

144-3094

1. The battery pack is charging.
2. The battery pack is fully charged.
3. The battery pack is over or under the appropriate temperature range.
4. Battery pack charging fault charged.



144-3098



144-3096

decal137-9461

decal144-3094

decal140-8475

decal144-3098

decal144-3096

# Setup

**Important:** The battery pack is not fully charged when you purchase it. Before using the tool for the first time, refer to [Charging the Battery Pack \(page 11\)](#).

## Assembling the Blower

Slide the blower tube onto the blower housing. You may need to press down on the tube latch for the blower tube to lock into place (Figure 3).

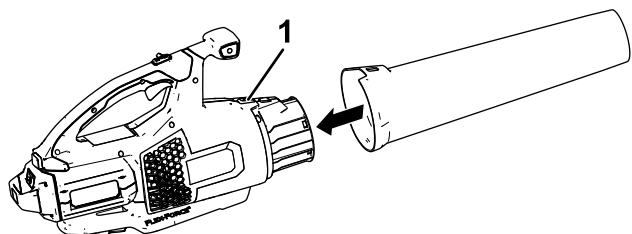
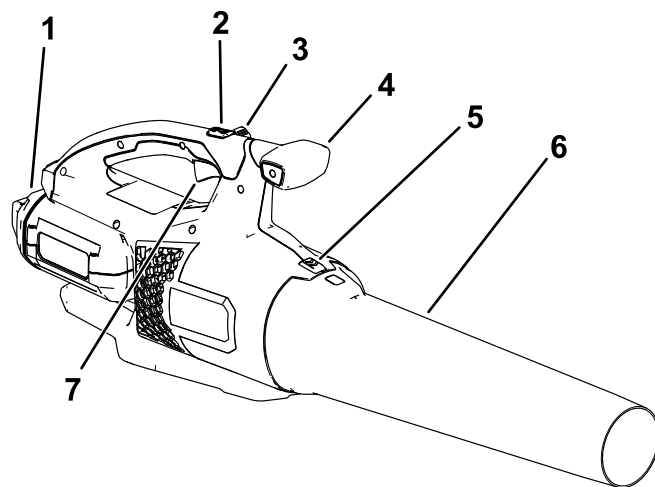

Figure 3

g273147

1. Tube latch

# Product Overview



g335835

Figure 4

1. Battery and battery cavity
2. Turbo boost button
3. Speed lock
4. Handle knob
5. Blower tube latch
6. Blower tube
7. Variable-speed trigger

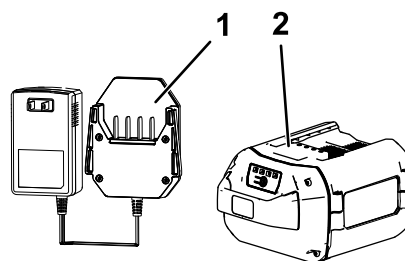

g330065

Figure 5

1. Battery charger Model 88610 (included with Model 51824)
2. Battery pack Model 88620 (included with Model 51824)



# Specifications

Model	51824
Rated Voltage	60V DC maximum, 54 VDC nominal usage
Charger Type	Toro 60V lithium-ion chargers
Battery Type	Toro 60V lithium-ion batteries

## Appropriate Temperature Ranges

Charge/ store the battery pack at	5°C (41°F) to 40°C (104°F)*
Use the battery pack at	-30°C (-22°F) to 49°C (120°F)
Use the blower at	0°C (32°F) to 49°C (120°F)

\*Charging time will increase if you do not charge the battery within this range.

Store the tool, battery pack, and battery charger in an enclosed clean, dry area.

## Attachments/Accessories

A selection of Toro approved attachments and accessories is available for use with the machine to enhance and expand its capabilities. Contact your Authorized Service Dealer or authorized Toro distributor or go to [www.Toro.com](http://www.Toro.com) for a list of all approved attachments and accessories.

To ensure optimum performance and continued safety certification of the machine, use only genuine Toro replacement parts and accessories. Replacement parts and accessories made by other manufacturers could be dangerous.

# Operation

## ⚠ WARNING

The blower can throw debris, possibly causing serious personal injury to you or bystanders.

- Do not blow hard objects, such as nails or bolts.
- Do not operate the blower near bystanders or pets.
- Be careful of blowing direction (i.e., blow away from bystanders, windows, automobiles, etc.). Only use as much speed as required.
- Use extra care when cleaning debris from stairs or other tight areas.

## Starting the Blower

**Important:** Use the battery pack only in temperatures that are within the appropriate range; refer to [Specifications \(page 9\)](#).

1. Make sure that the vents on the blower are clear of any dust and debris.
2. Align the cavity on the battery pack with the tongue in the handle housing ([Figure 6](#)).
3. Grasp the handle, and push the battery pack into the handle until the latch locks into place ([Figure 6](#)).

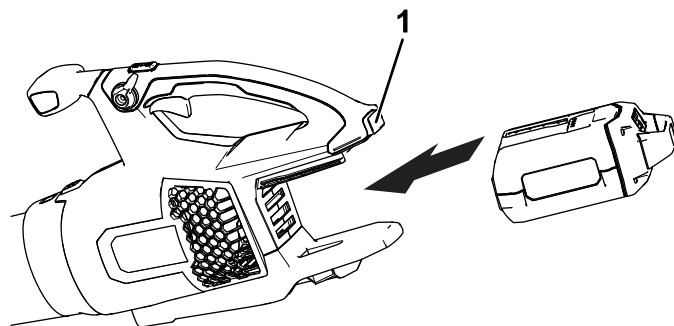

Figure 6

g273146

1. Battery latch

4. To start the blower, squeeze the variable-speed trigger ([Figure 7](#)).

**Note:** Engage the speed lock to keep the machine on without pressing the variable-speed trigger ([Figure 7](#)).

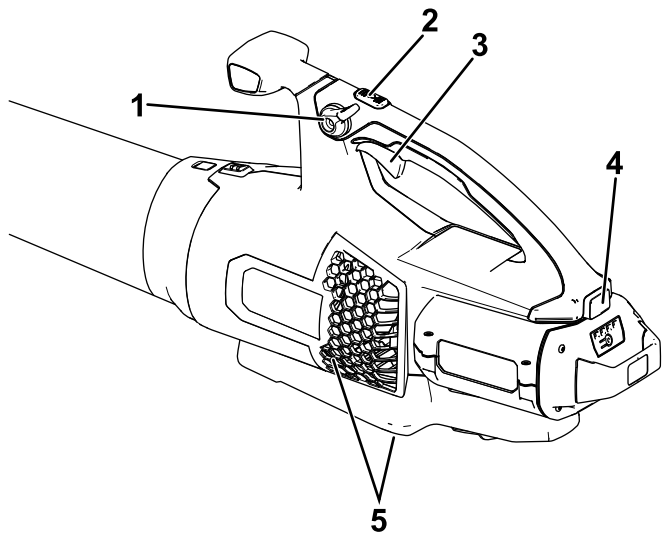

Figure 7

g267241

- |                           |                         |
|---------------------------|-------------------------|
| 1. Speed lock             | 4. Battery latch        |
| 2. Turbo boost button     | 5. Blower venting areas |
| 3. Variable-speed trigger |                         |

## Adjusting the Air Speed of the Blower

To achieve maximum performance (air speed), fully depress the variable-speed trigger, then press and hold the turbo boost button for the desired amount of time (Figure 7).

To adjust the air speed as you blow, use the variable-speed trigger (Figure 7).

To maintain the current air speed, engage the speed lock (Figure 7).

## Shutting Off the Blower

To shut off the blower, disengage the speed lock (if in use) and release the variable-speed trigger (Figure 7).

**Important:** After stopping the blower, do not leave the speed lock engaged with the battery pack in the blower.

Whenever you are not using the blower or are transporting the blower to or from the work area, remove the battery pack.

## Removing the Blower Tube

Press down on the tube latch to separate the blower tube from the blower (Figure 8).

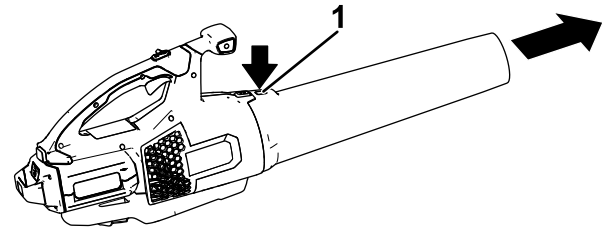

Figure 8

g273159

1. Tube latch

# Removing the Battery from the Blower

Press the battery latch to release the battery pack and slide the battery pack out of the blower (Figure 9).

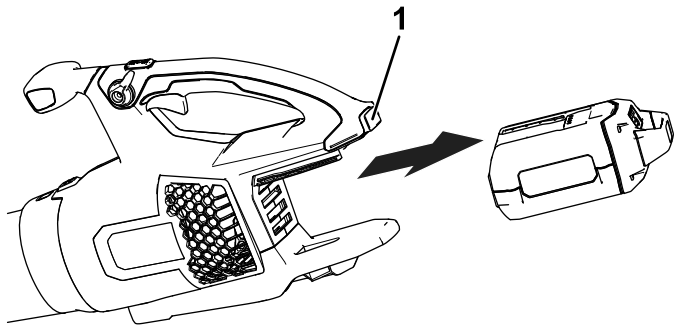

Figure 9

g267488

1. Battery latch

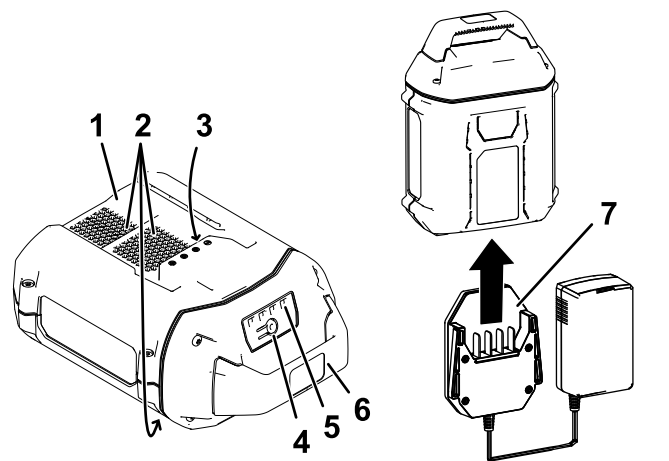

Figure 10

g330066

1. Battery pack cavity
2. Battery pack venting areas
3. Battery pack terminals
4. Battery-charge-indicator button
5. LED indicators (current charge)
6. Handle
7. Charger

# Charging the Battery Pack

**Important:** The battery pack is not fully charged when you purchase it. Before using the tool for the first time, place the battery pack in the charger and charge it until the LED display indicates the battery pack is fully charged. Read all safety precautions.

**Important:** Charge the battery pack only in temperatures that are within the appropriate range; refer to [Specifications \(page 9\)](#).

**Note:** At any time, press the battery-charge-indicator button on the battery pack to display the current charge (LED indicators).

1. Ensure that the vents on the battery and charger are clear of any dust and debris.

2. Line up the charger with the cavity on the back of the battery pack (Figure 10).
3. Slide the charger into the battery pack until it is fully seated (Figure 10).
4. To remove the charger, slide the charger backward out of the battery.
5. Refer to the following table to interpret the LED indicator light on the battery charger.

Indicator light	Indicates
Off	No battery pack inserted
Green blinking	Battery pack is charging
Green	Battery pack is charged
Red	Battery pack and/or battery charger is over or under the appropriate temperature range
Red blinking	Battery pack charging fault*

\*Refer to [Troubleshooting \(page 13\)](#) for more information.

**Important:** The battery can be left on the charger for short periods between uses.

If the battery will not be used for longer periods, remove the battery from the charger; refer to [Storage \(page 12\)](#).

## Storage

**Important:** Store the tool, battery pack, and charger only in temperatures that are within the appropriate range; refer to [Specifications \(page 9\)](#).

**Important:** If you are storing the battery pack for the off-season, remove the battery pack from the tool and charge the battery pack until 2 or 3 LED indicators turn green on the battery. Do not store a fully charged or fully depleted battery. When you are ready to use the tool again, charge the battery pack until the left indicator light turns green on the charger or all 4 LED indicators turn green on the battery.

- Disconnect the product from the power supply (i.e., remove the plug from the power supply or the battery pack) and check for damage after use.
- Do not store the tool with the battery pack installed.
- Clean all foreign material from the product.
- When not in use, store the tool, battery pack, and battery charger out of the reach of children.
- Keep the tool, battery pack, and battery charger away from corrosive agents, such as garden chemicals and de-icing salts.
- To reduce the risk of serious personal injury, do not store the battery pack outside or in vehicles.
- Store the tool, battery pack, and battery charger in an enclosed clean, dry area.

## Preparing the Battery Pack for Recycling

**Important:** Upon removal, cover the terminals of the battery pack with heavy-duty adhesive tape. Do not attempt to destroy or disassemble the battery pack or remove any of its components.



Lithium-ion battery packs labeled with the Call2Recycle seal can be recycled at any participating retailer or battery recycling facility in the Call2Recycle program (US and Canada only). To locate a participating retailer or facility closest to you, please call 1-800-822-8837 or visit [www.call2recycle.org](http://www.call2recycle.org). If you cannot locate a participating retailer or facility nearby, or if your rechargeable battery is not labeled with the Call2Recycle seal, please contact your local municipality for more information on how to responsibly recycle the battery. If you are located outside of the US and Canada, please contact your authorized Toro distributor.

# Troubleshooting

Perform only the steps described in these instructions. All further inspection, maintenance, and repair work must be performed by an authorized service center or a similarly qualified specialist if you cannot solve the problem yourself.

Always remove the battery from the tool when troubleshooting, inspecting, maintaining, or cleaning the tool.

Problem	Possible Cause	Corrective Action
The tool does not start.	<ol style="list-style-type: none"> <li>1. The battery is not fully installed in the tool.</li> <li>2. The battery pack is not charged.</li> <li>3. The battery pack is damaged.</li> <li>4. There is another electrical problem with the tool.</li> </ol>	<ol style="list-style-type: none"> <li>1. Remove and then replace the battery into the tool, making sure that it is fully installed and latched.</li> <li>2. Remove the battery pack from the tool and charge it.</li> <li>3. Replace the battery pack.</li> <li>4. Contact an Authorized Service Dealer.</li> </ol>
The tool does not reach full power.	<ol style="list-style-type: none"> <li>1. The battery pack charge capacity is too low.</li> <li>2. The air vents are blocked.</li> </ol>	<ol style="list-style-type: none"> <li>1. Remove the battery pack from the tool and fully charge the battery pack.</li> <li>2. Clean the air vents.</li> </ol>
The tool does not run or does not run continuously.	<ol style="list-style-type: none"> <li>1. There is moisture on the leads of the battery pack.</li> <li>2. The battery is not fully installed in the tool.</li> <li>3. The battery pack is low on charge.</li> </ol>	<ol style="list-style-type: none"> <li>1. Allow the battery pack to dry or wipe it dry.</li> <li>2. Remove and then replace the battery in the tool, ensuring that it is fully installed and latched.</li> <li>3. Charge the battery pack.</li> </ol>
The speed lock does not hold when engaged.	<ol style="list-style-type: none"> <li>1. The speed lock screw is loose.</li> </ol>	<ol style="list-style-type: none"> <li>1. Tighten the speed lock screw by turning the speed lock screw <math>\frac{1}{4}</math> turn. If the speed lock still does not hold when engaged, turn the speed lock screw an additional <math>\frac{1}{4}</math> turn.</li> </ol>
The battery pack loses charge quickly.	<ol style="list-style-type: none"> <li>1. The battery pack is over or under the appropriate temperature range.</li> </ol>	<ol style="list-style-type: none"> <li>1. Move the battery pack to a place where it is dry and the temperature is between 5°C (41°F) and 40°C (104°F).</li> </ol>
The battery charger is not working.	<ol style="list-style-type: none"> <li>1. The battery charger is over or under the appropriate temperature range.</li> <li>2. The outlet that the battery charger is plugged into does not have power.</li> </ol>	<ol style="list-style-type: none"> <li>1. Unplug the battery charger and move it to a place where it is dry and the temperature is between 5°C (41°F) and 40°C (104°F).</li> <li>2. Contact your licensed electrician to repair the outlet.</li> </ol>
The LED indicator light on the battery charger is red.	<ol style="list-style-type: none"> <li>1. The battery charger and/or battery pack is over or under the appropriate temperature range.</li> </ol>	<ol style="list-style-type: none"> <li>1. Unplug the battery charger and move the battery charger and battery pack to a place where it is dry and the temperature is between 5°C (41°F) and 40°C (104°F).</li> </ol>

Problem	Possible Cause	Corrective Action
<p>The LED indicator light on the battery charger is blinking red.</p>	<ol style="list-style-type: none"> <li>1. There is an error in the communication between the battery pack and the charger.</li> <li>2. The battery pack is weak.</li> </ol>	<ol style="list-style-type: none"> <li>1. Remove the battery pack from the battery charger, unplug the battery charger from the outlet, and wait 10 seconds. Plug the battery charger into the outlet again and place the battery pack on the battery charger. If the LED indicator light on the battery charger is still blinking red, repeat this procedure again. If the LED indicator light on the battery charger is still blinking red after 2 attempts, properly dispose of the battery pack at a battery recycling facility.</li> <li>2. Properly dispose of the battery pack at a battery recycling facility.</li> </ol>

# California Proposition 65 Warning Information

## What is this warning?

You may see a product for sale that has a warning label like the following:



**WARNING: Cancer and Reproductive Harm—[www.p65Warnings.ca.gov](http://www.p65Warnings.ca.gov).**

## What is Prop 65?

Prop 65 applies to any company operating in California, selling products in California, or manufacturing products that may be sold in or brought into California. It mandates that the Governor of California maintain and publish a list of chemicals known to cause cancer, birth defects, and/or other reproductive harm. The list, which is updated annually, includes hundreds of chemicals found in many everyday items. The purpose of Prop 65 is to inform the public about exposure to these chemicals.

Prop 65 does not ban the sale of products containing these chemicals but instead requires warnings on any product, product packaging, or literature with the product. Moreover, a Prop 65 warning does not mean that a product is in violation of any product safety standards or requirements. In fact, the California government has clarified that a Prop 65 warning "is not the same as a regulatory decision that a product is 'safe' or 'unsafe.'" Many of these chemicals have been used in everyday products for years without documented harm. For more information, go to <https://oag.ca.gov/prop65/faqs-view-all>.

A Prop 65 warning means that a company has either (1) evaluated the exposure and has concluded that it exceeds the "no significant risk level"; or (2) has chosen to provide a warning based on its understanding about the presence of a listed chemical without attempting to evaluate the exposure.

## Does this law apply everywhere?

Prop 65 warnings are required under California law only. These warnings are seen throughout California in a wide range of settings, including but not limited to restaurants, grocery stores, hotels, schools, and hospitals, and on a wide variety of products. Additionally, some online and mail order retailers provide Prop 65 warnings on their websites or in catalogs.

## How do the California warnings compare to federal limits?

Prop 65 standards are often more stringent than federal and international standards. There are various substances that require a Prop 65 warning at levels that are far lower than federal action limits. For example, the Prop 65 standard for warnings for lead is 0.5 µg/day, which is well below the federal and international standards.

## Why don't all similar products carry the warning?

- Products sold in California require Prop 65 labelling while similar products sold elsewhere do not.
- A company involved in a Prop 65 lawsuit reaching a settlement may be required to use Prop 65 warnings for its products, but other companies making similar products may have no such requirement.
- The enforcement of Prop 65 is inconsistent.
- Companies may elect not to provide warnings because they conclude that they are not required to do so under Prop 65; a lack of warnings for a product does not mean that the product is free of listed chemicals at similar levels.

## Why does the manufacturer include this warning?

the manufacturer has chosen to provide consumers with as much information as possible so that they can make informed decisions about the products they buy and use. the manufacturer provides warnings in certain cases based on its knowledge of the presence of one or more listed chemicals without evaluating the level of exposure, as not all the listed chemicals provide exposure limit requirements. While the exposure from the manufacturer products may be negligible or well within the "no significant risk" range, out of an abundance of caution, the manufacturer has elected to provide the Prop 65 warnings. Moreover, if the manufacturer does not provide these warnings, it could be sued by the State of California or by private parties seeking to enforce Prop 65 and subject to substantial penalties.



**Count on it.**