



Count on it.

Operator's Manual

Field Pro 6040

Model No. 08839—Serial No. 40000000 and Up

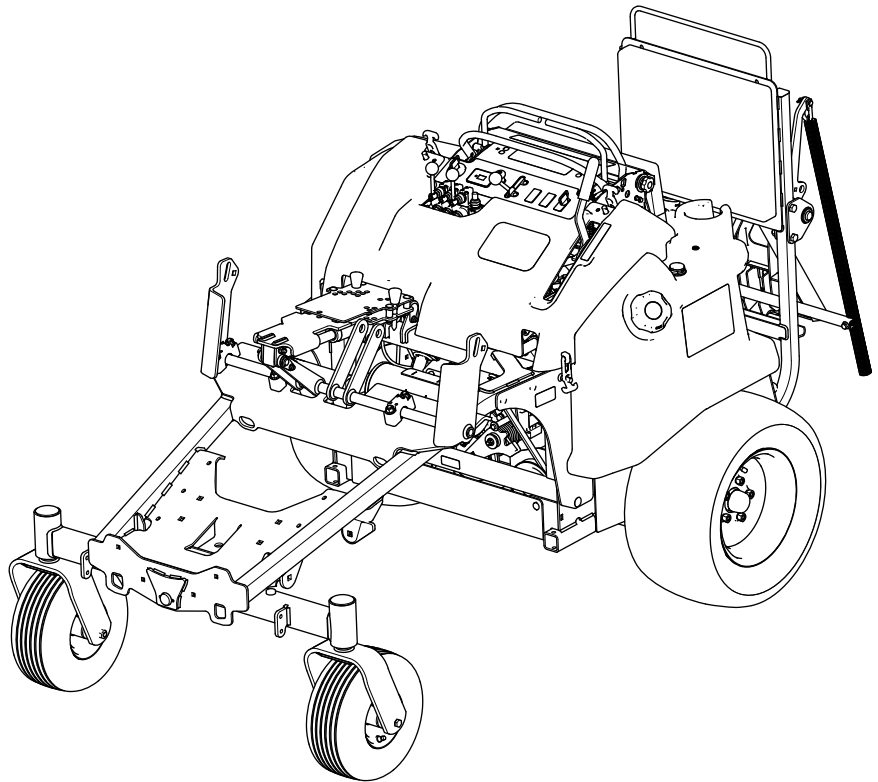

Contents

Safety	4	Checking the Engine-Oil Level	50
General Safety	4	Changing the Engine Oil and Filter	51
Safety and Instructional Decals	5	Servicing the Air Cleaner	53
Setup	9	Servicing the Spark Plug(s)	53
1 Installing a Mid-Mount Attachment	9	Fuel System Maintenance	55
2 Preparing the Machine	10	Changing the Fuel Filter	55
3 Installing the Rear Attachment Lift		Draining the Fuel Tank	55
Frame	10	Electrical System Maintenance	56
Product Overview	17	Replacing the Fuses	56
Controls	18	Drive System Maintenance	57
Engine and Attachment Controls	18	Checking the Tire Air Pressure	57
Parking Brake and Motion Control	19	Torquing the Wheel Lug Nuts	57
Specifications	19	Torquing the Caster Wheel Nuts	57
Before Operation	20	Belt Maintenance	58
Before Operation Safety	20	Replacing the Belt	58
Fueling the Machine	20	Hydraulic System Maintenance	59
Before Operations Checks	21	Hydraulic System Safety	59
Checking the Safety-Interlock System	21	Checking the Hydraulic Lines and	
Adjusting the Backrest Position	22	Hoses	59
During Operation	23	Hydraulic-Fluid Specifications	59
During Operation Safety	23	Checking the Hydraulic-Fluid Level	59
Operating the Parking Brake	24	Changing the Hydraulic Filter	60
Starting the Engine	24	Changing the Hydraulic Fluid	61
Shutting Off the Engine	25	Cleaning	62
Driving the Machine	26	Cleaning the Machine	62
Adjusting the Height of the Mid-Mount			
Attachment	27		
Adjusting the Tilt Angle of the Mid-Mount			
Attachment	28		
Selecting the Multi-Tool	29		
Mid-Mount Attachment Stop	31		
Calibrating Mid-Mount Attachment			
Stop	36		
Raising and Lowering the Optional Rear			
Attachment	38		
Operating Tips	39		
After Operation	40		
After Operation Safety	40		
Moving a Non-Functioning Machine	40		
Transporting the Machine	41		
Maintenance	43		
Maintenance Safety	43		
Recommended Maintenance Schedule(s)	43		
Daily Maintenance Checklist	44		
Pre-Maintenance Procedures	45		
Preparing for Maintenance	45		
Removing the Hood	46		
Installing the Hood	46		
Lowering the Operator's Cushion	47		
Raising the Operator's Cushion	47		
Lifting the Machine	48		
Lubrication	49		
Greasing the Bearings and Bushings	49		
Engine Maintenance	50		
Engine Safety	50		
Engine Oil Specification	50		

Safety

This machine has been designed in accordance with ANSI B71.4-2017 and complies with this standard when a Toro-approved mid-mount attachment is installed; do not operate this machine without a mid-mount attachment installed.

General Safety

This product is capable of causing personal injury. Always follow all safety instructions to avoid serious personal injury.

- Read and understand the contents of this *Operator's Manual* before starting the engine.
- Do not put your hands or feet near moving components of the machine.
- Do not operate the machine without all guards and other safety protective devices in place and functioning properly on the machine.
- Use your full attention while operating the machine. Do not engage in any activity that causes distractions; otherwise, injury or property damage may occur.
- Keep bystanders and children out of the operating area. Do not allow children to operate the machine. Allow only people who are responsible, trained, familiar with the instructions, and physically capable to operate the machine.
- Stop the machine, shut off the engine, and remove the ignition key before servicing or fueling the machine.

Improperly using or maintaining this machine can result in injury. To reduce the potential for injury, comply with these safety instructions and always pay attention to the safety-alert symbol ▲, which means Caution, Warning, or Danger—personal safety instruction. Failure to comply with these instructions may result in personal injury or death.

You can find additional safety information where needed throughout this manual.

Safety and Instructional Decals



Safety decals and instructions are easily visible to the operator and are located near any area of potential danger. Replace any decal that is damaged or missing.



decal145-1772

145-1772

1. Warning—read the *Operator's Manual*.
2. Warning—all operators should be trained before operating the machine.
3. Warning—wear hearing protection.
4. Warning—stay away from moving parts; keep all guards and shields in place.
5. Thrown object hazard—keep bystanders away.
6. Warning—engage the parking brake, shut off the engine, and remove the key before leaving the machine or performing maintenance.
7. Tipping hazard—do not use dual ramps when loading onto a trailer; use 1 ramp wide enough for the machine; use a ramp with a slope less than 15° ; back up the ramp when loading the machine and drive forward off the ramp when unloading.
8. Tipping hazard—do not turn sharply while traveling fast; drive slowly when turning; do not use the machine near drop-offs or on slopes; stay at least 2 widths of the machine away from drop-offs.

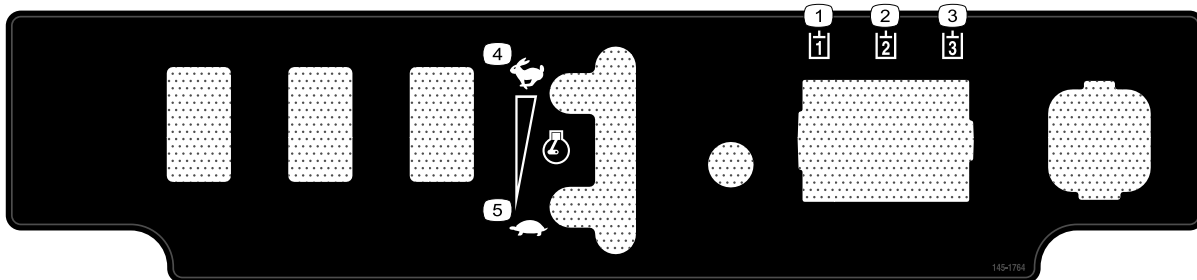

decal145-1764

145-1764

1. Raise/lower the mid-mount attachment
2. Tilt the mid-mount attachment forward/backward
3. Raise/lower the rear attachment
4. Fast
5. Slow

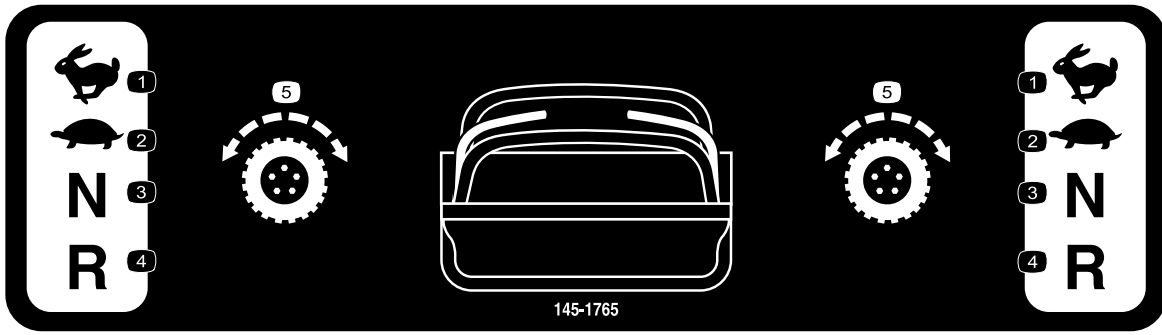

145-1765

145-1765

decal145-1765

- 1. Fast
- 2. Slow
- 3. Neutral
- 4. Reverse
- 5. Traction drive



145-1774

decal145-1774

- 1. Crushing hazard of hands and feet—keep hands and feet away from multi-tool carrier.



decalbatterysymbols

Battery Symbols

Some or all of these symbols are on your battery.

- 1. Explosion hazard
- 2. No fire, open flame, or smoking
- 3. Caustic liquid/chemical burn hazard
- 4. Wear eye protection.
- 5. Read the *Operator's Manual*.
- 6. Keep bystanders away from the battery.
- 7. Wear eye protection; explosive gases can cause blindness and other injuries.
- 8. Battery acid can cause blindness or severe burns.
- 9. Flush eyes immediately with water and get medical help fast.
- 10. Contains lead; do not discard



145-1777

decal145-1777

- 1. Warning—read the *Operator's Manual*.
- 2. Thrown object hazard—keep bystanders away.
- 3. Cutting/dismemberment hazard of hands and feet—keep your hands and feet away from moving parts.

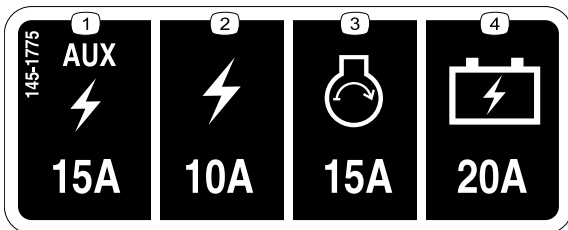

145-1775

decal145-1775

- 1. Auxiliary hydraulic power
- 2. Power
- 3. Engine start
- 4. Battery



1

58-6520

decal58-6520

- 1. Grease

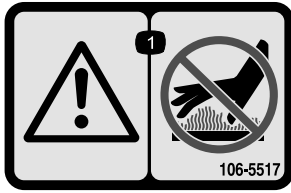

106-5517

decal106-5517

1. Warning—do not touch the hot surface.

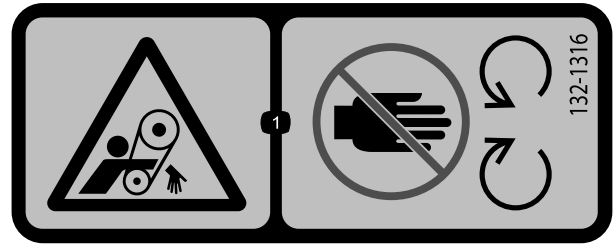

132-1316

decal132-1316

1. Entanglement hazard, belt—keep away from moving parts.

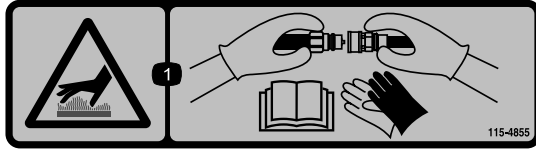

115-4855

decal115-4855

1. Hot surface/burn hazard—wear protective gloves when handling the hydraulic couplers and read the *Operator's Manual* for information on handling hydraulic components.



133-8062

decal133-8062



138-4107

decal138-4107

1. Crushing hazard of the hand—keep hands away from the pinch point.

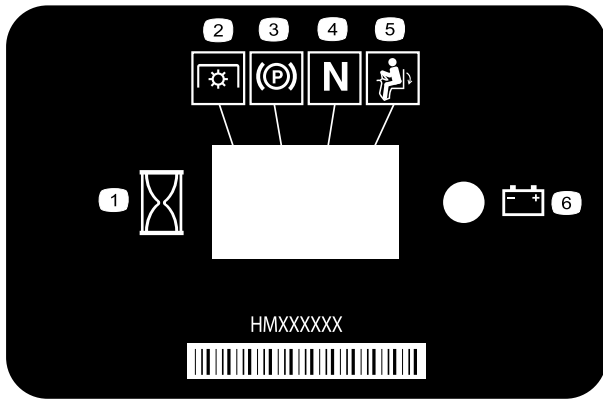

116-5610

decal116-5610

- | | |
|-------------------------|----------------------------------------|
| 1. Hour meter | 4. Neutral |
| 2. Power take-off (PTO) | 5. Operator presence switch (Optional) |
| 3. Parking brake | 6. Battery |

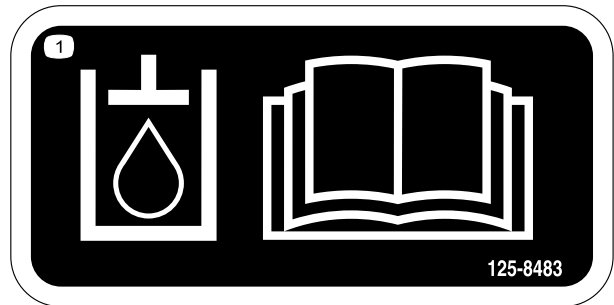

125-8483

decal125-8483

1. Hydraulic fluid; read the *Operator's Manual*.



137-9505

decal137-9505

1. Do not use fuel with an alcohol content by volume greater than 10%.



120-9570

decal120-9570

1. Warning—stay away from moving parts, keep all guards and shields in place.

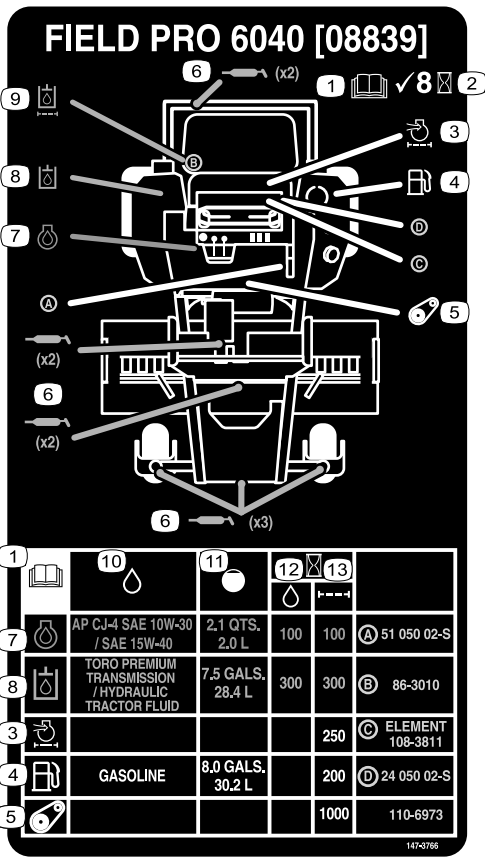

147-3766

decal147-3766

1. Read the *Operator's Manual* before performing maintenance.
2. Check every 8 hours.
3. Engine air filter
4. Fuel
5. Belt
6. Grease point
7. Engine oil
8. Hydraulic fluid
9. Hydraulic fluid filter
10. Fluid specification
11. Capacity
12. Fluid change interval (hours)
13. Filter change interval (hours)

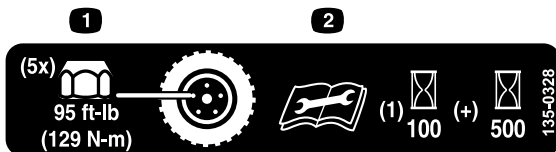

135-0328

decal135-0328

1. Wheel lug nut torque 95 ft-lb (129 N-m) (5x)
2. Read and understand the *Operator's Manual* before performing any maintenance, check torque after first 100 hours then every 500 hours thereafter.

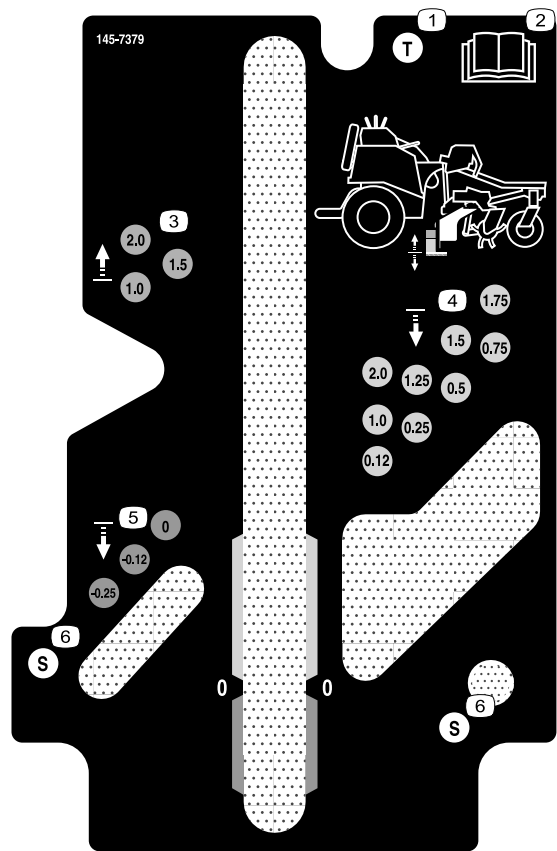

145-7379

decal145-7379

1. Transport and maintenance position
2. Read the *Operator's Manual*.
3. Up-stop positions
4. Above-grade positions
5. Grade- or Below-grade positions
6. Stow positions

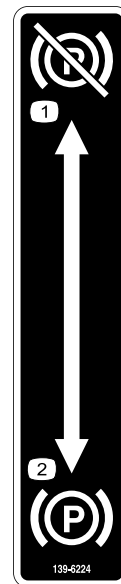

139-6224

decal139-6224

1. Parking brake—disengaged
2. Parking brake—engaged

Setup

Loose Parts

Use the chart below to verify that all parts have been shipped.

Procedure	Description	Qty.	Use
1	Mid-mount attachment (ordered separately; refer to your authorized Toro distributor)	1	Install a mid-mount attachment.
2	No parts required	–	Prepare the machine.
3	Short drawbar chain (17-1/2 inches) Lift bracket Carriage bolt (5/16 x 1 inch) Washer (3/8 x 7/8 inch) Flange locknut (5/16 inch) Rear attachment lift frame assembly Long rear-lift chain (25 inches) Shackle Clevis pin Cotter pin Flange-head bolt (3/8 x 1-3/4 inches) Washer (2/5 inch) Flange locknut (3/8 inch) Chain sleeve Flange-head bolt (1/2 x 3 inches) Flange locknut (1/2 inch) Capscrew (3/4 x 4-1/2 inches) Locknut (3/4 inch) Flange-head bolt (3/8 x 1-1/2 inches)	2 1 6 4 6 1 2 2 2 2 2 2 3 2 6 6 1 1 1	Assemble the rear attachment lift frame.

1

Installing a Mid-Mount Attachment

Parts needed for this procedure:

1	Mid-mount attachment (ordered separately; refer to your authorized Toro distributor)
---	--------------------------------------------------------------------------------------

Procedure

Install a Toro-approved mid-mount attachment; refer to the mid-mount attachment *Installation Instructions*.

2

Preparing the Machine

No Parts Required

Procedure

1. Remove the machine from the crate, park the machine on a level surface or move the machine to a machine lift.
2. Engage the parking brake.
3. Lower the mid-mount attachment.
4. Shut off the engine and remove the key.
5. Wait for all moving parts to stop and allow the engine to cool.
6. Move the mid-mount attachment control forward and backward to relieve hydraulic pressure (Figure 3).

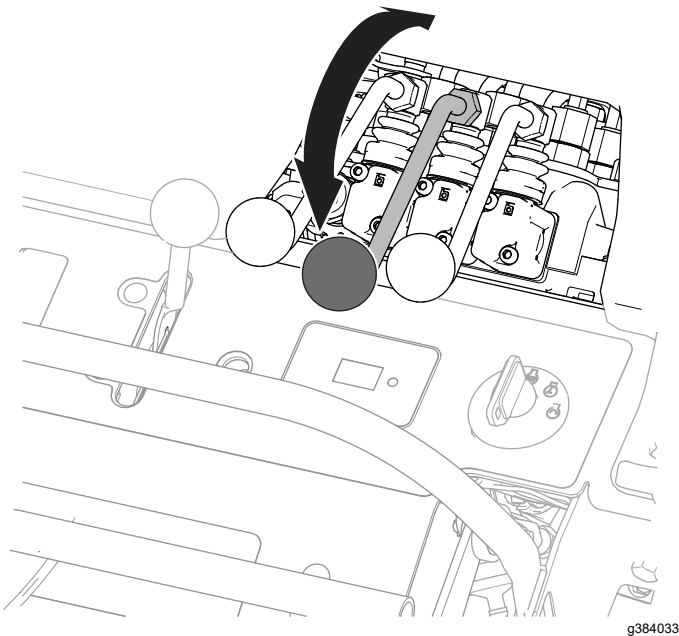

Figure 3

3

Installing the Rear Attachment Lift Frame

Parts needed for this procedure:

2	Short drawbar chain (17-1/2 inches)
1	Lift bracket
6	Carriage bolt (5/16 x 1 inch)
4	Washer (3/8 x 7/8 inch)
6	Flange locknut (5/16 inch)
1	Rear attachment lift frame assembly
2	Long rear-lift chain (25 inches)
2	Shackle
2	Clevis pin
2	Cotter pin
2	Flange-head bolt (3/8 x 1-3/4 inches)
2	Washer (2/5 inch)
3	Flange locknut (3/8 inch)
2	Chain sleeve
6	Flange-head bolt (1/2 x 3 inches)
6	Flange locknut (1/2 inch)
1	Capscrew (3/4 x 4-1/2 inches)
1	Locknut (3/4 inch)
1	Flange-head bolt (3/8 x 1-1/2 inches)

Assembling the Drawbar Chains to the Machine

1. Raise the operator's platform (Figure 4).

Note: The operator's platform does not stay in the upright position; restrain the platform or hold it in place while completing this procedure.

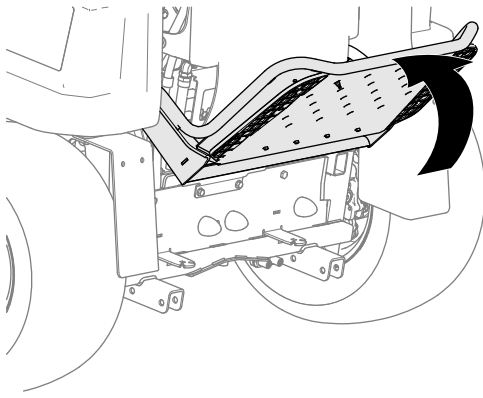

Figure 4

g374088

- Align the link at the end of a short drawbar chain to the hole in the chain tab of the rear frame plate (Figure 5).

Ensure the link is flush to the chain tab and the next link aligns into the groove in the tab.

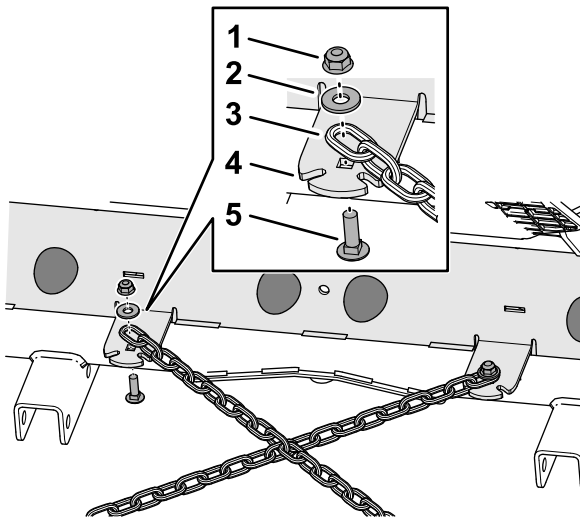

Figure 5

g361582

- Flange locknut (5/16 inch)
- Washer (3/8 x 7/8 inch)
- Short drawbar chain (17-1/2 inches)
- Chain tab (rear frame plate)
- Carriage bolt (5/16 x 1 inch)

- Assemble the chain to the chain tab with a carriage bolt (5/16 x 1 inch), washer (3/8 x 7/8 inch), and flange locknut (5/16 inch) as shown in Figure 5.
- Torque the locknut to 19.8 to 25.4 N·m (175 to 225 in-lb).
- Repeat steps 2 through 4 for the other short drawbar chain at the chain tab at the other side of the machine.

Preparing the Rear Attachment Adapter and Drawbar

- Install the lift bracket to the rear frame assembly as shown in Figure 6.

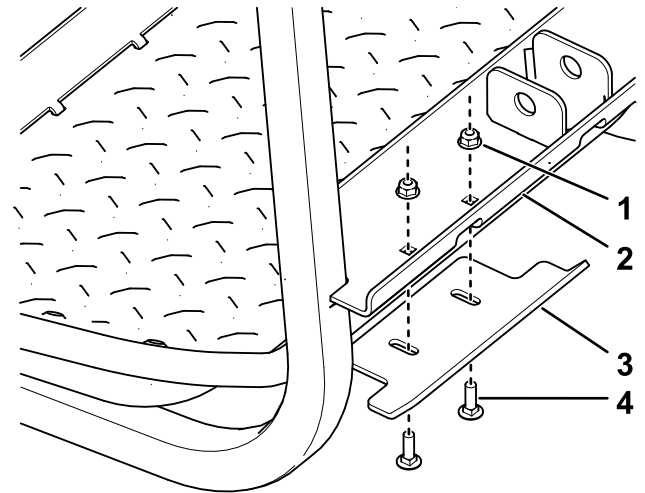

Figure 6

g392492

- Flange locknut (5/16 inch)
- Rear frame assembly
- Lift bracket
- Carriage bolt (5/16 x 1 inch)

- Install the tow-stop bracket to the drawbar with a U-bolt and 2 flange locknuts (5/16 inch) as shown in Figure 11.

Note: Install the bracket with the tabs facing the front of the machine.

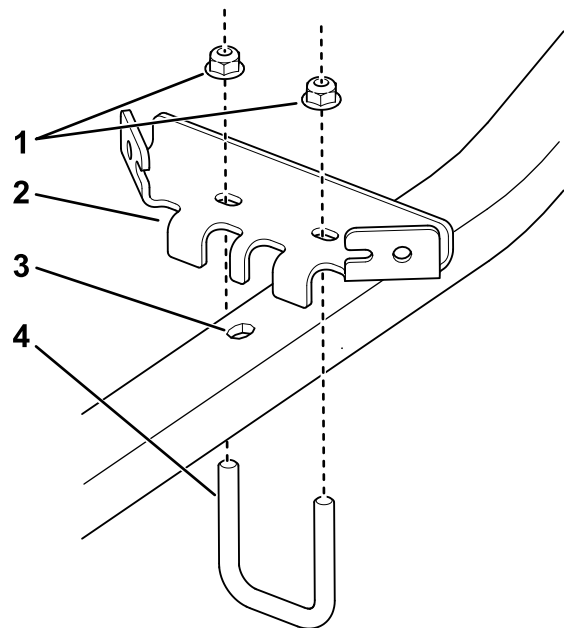

Figure 7

g383944

- Flange locknuts (5/16 inch)
- Tow-stop bracket
- Center bracket tab alignment hole
- U-bolt

3. Connect the rear attachment adapter assembly to the drawbar with a hex-head bolt (3/4 x 3-1/2 inches), flat washer, and a locknut (3/4 inch) as shown in [Figure 8](#).

Note: Install the screw through the rearmost hole in the adapter assembly and drawbar.

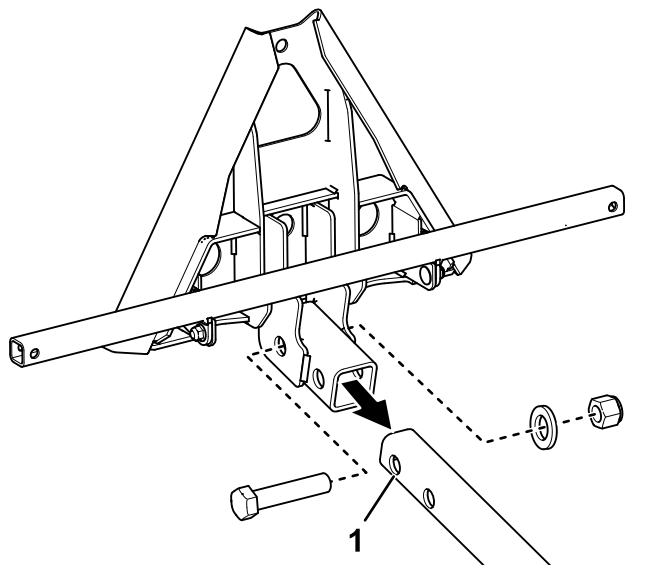

Figure 8

1. Install the attachment adapter here.

4. Install the lift chains to the lift-bar assembly with flange-head bolts (3/8 x 1-3/4 inches), washers (3/8 inch), and locknuts (3/8 inch).
5. Slide the chain sleeves onto the lift chains, and then install the lift chains to the shaft-lift assembly with shackles, clevis pins, and cotter pins.

Assembling the Lift Frame to the Machine

1. Connect the second link of the long rear-lift chains to the top of the lift frame using shackles, clevis pins, and cotter pins ([Figure 9](#)).

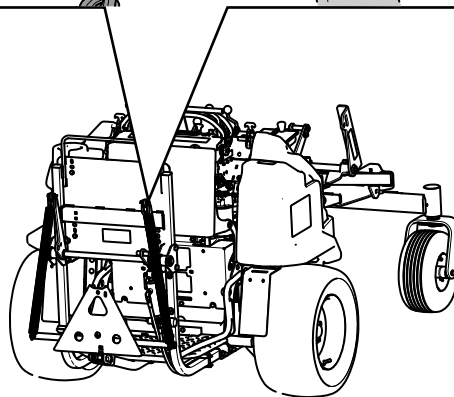
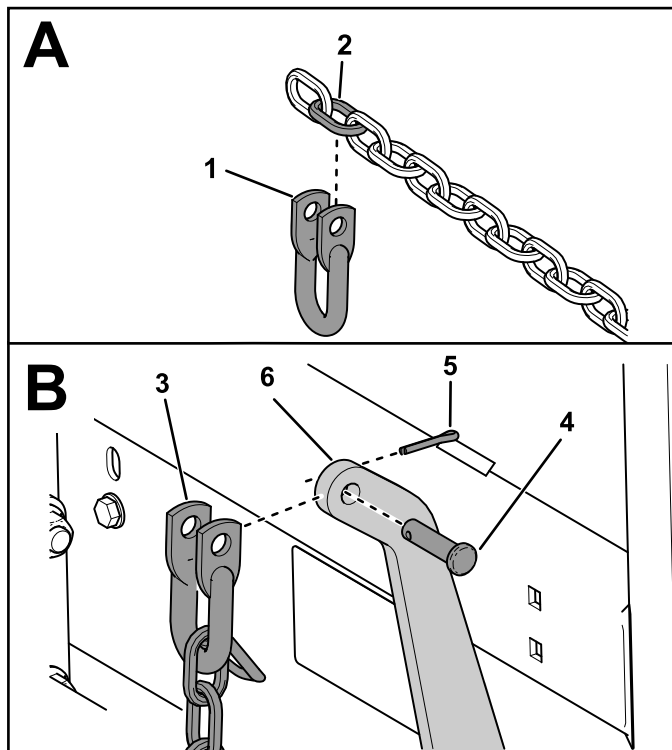

Figure 9

- | | |
|----------------------------------------------------------------|---------------|
| 1. Shackle | 4. Clevis pin |
| 2. Long rear-lift chain (second link) | 5. Cotter pin |
| 3. Align the shackle and chain with the hole in the lift frame | 6. Lift frame |

- Connect the bottom of the long rear-lift chains to the hanger tube at the bottom of the lift frame using flange-head bolts (3/8 x 1-3/4 inches), washers (2/5 inch), and flange locknuts (3/8 inches) as shown in [Figure 10](#).

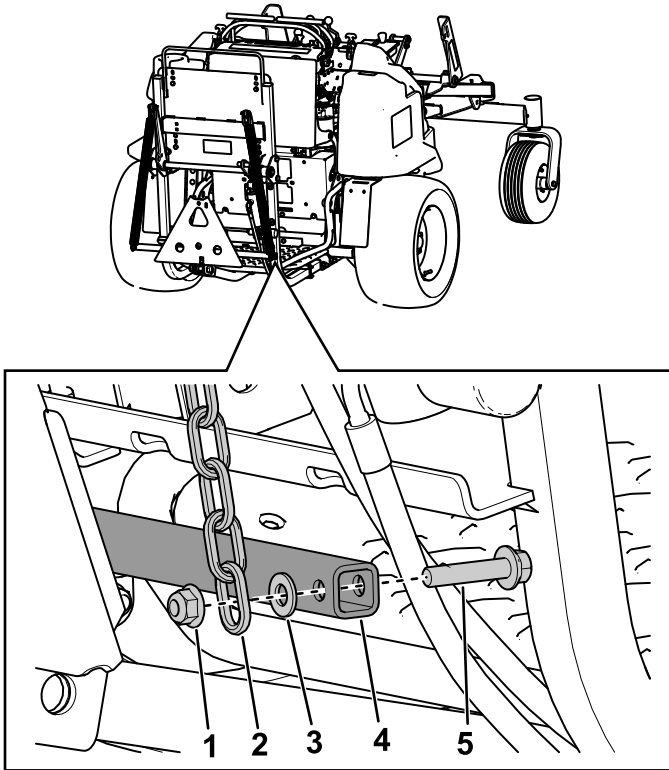

Figure 10

- Flange locknut (3/8 inches)
- Long rear-lift chain
- Washer (2/5 inch)
- Hanger tube
- Flange-head bolt (3/8 x 1-3/4 inches)

- Align the rear attachment lift frame under the machine ([Figure 11](#)).

Note: Ensure that the rear attachment lift frame is centered under the machine.

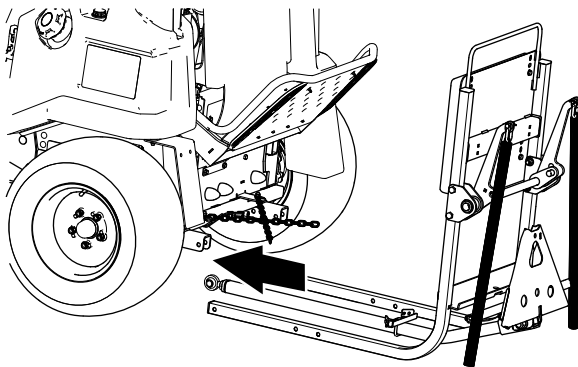

Figure 11

- Lift the back of the rear attachment lift frame to align the holes in the lift-frame tubes with the holes in the channels of the rear frame ([Figure 12](#)).

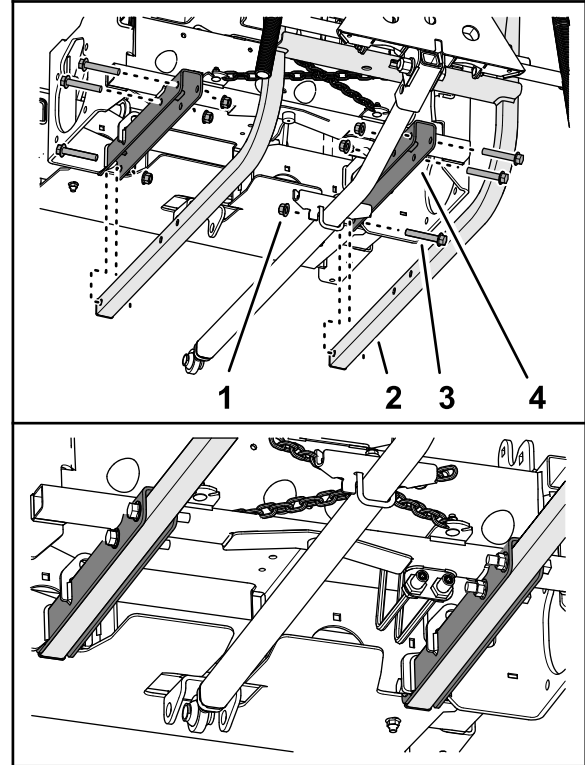

Figure 12

- Flange locknut (1/2 inch)
- Tube (rear attachment lift frame)
- Flange-head bolt (1/2 x 3 inches)
- Channel (rear frame)

Note: Install the hardware with the bolt heads toward the outside of the machine.

- Assemble the 6 flange-head bolts (1/2 x 3 inches) through the holes in the channels and the tubes.
- Assemble the 6 flange locknuts (1/2 inch) onto the flange-head bolts.
- Torque the flange-head bolts and locknuts to 91 to 113 N·m (67 to 83 ft-lb).

- Align the hole in the rod end of the drawbar with the holes in the drawbar mount of the rear-frame bulkhead (Figure 13).

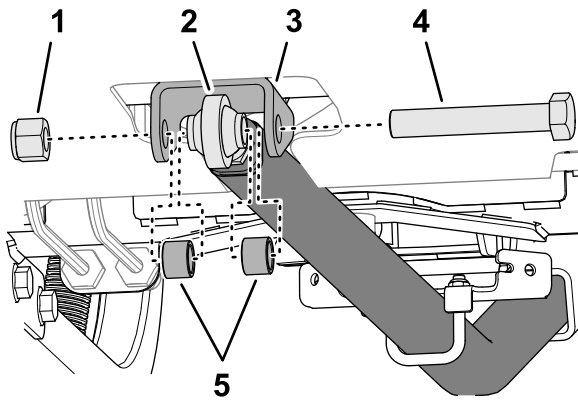

Figure 13

g361586

- | | |
|----------------------------------------|----------------------------------|
| 1. Locknut (3/4 inch) | 4. Capscrew (3/4 x 4-1/2 inches) |
| 2. Rod end (drawbar) | 5. Spacers |
| 3. Drawbar mount (rear-frame bulkhead) | |

- Assemble the rod end to the mount with the capscrew (3/4 x 4-1/2 inches), 2 spacer, and locknut (3/4 inch) as shown in Figure 13.
- Torque the capscrew and locknut to 320 to 396 N·m (238 to 392 ft-lb).

Assembling the Drawbar Chains to the Lift Frame

- Cross the attached chains from the (Figure 14) over the drawbar.

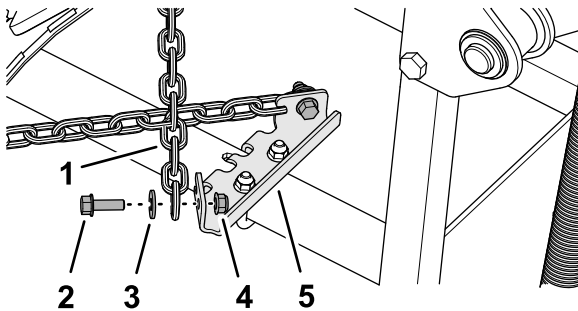

Figure 14

g392371

- | | |
|----------------------------------------|-------------------------------|
| 1. Short drawbar chain (17-1/2 inches) | 4. Flange locknut (5/16 inch) |
| 2. Flange-head bolt (5/16 x 1 inch) | 5. Tow-stop bracket (drawbar) |
| 3. Washer (3/8 x 7/8 inch) | |

- Pull the slack from the chain and align the link to the hole in the tow-stop bracket of the of the drawbar.

Ensure the link is flush to the outboard side of the bracket, and the next link forward aligns into the groove in the bracket.

- Assemble the chain to the stop bracket with a flange-head bolt (5/16 x 1 inch), washer (3/8 x 7/8 inch), and flange locknut (5/16 inch) as shown in Figure 14.
- Repeat steps 1 through 3 for the other chain at the other side of the stop bracket.
- Where the chains cross (Figure 15), assemble them with a flange-head bolt (3/8 x 1-1/2 inches) and flange locknut (3/8 inch).

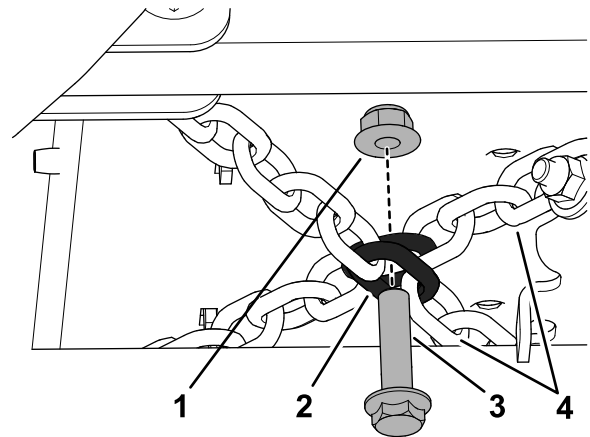

Figure 15

g392382

- | | |
|------------------------------------------------------------------------------------|------------------------------------------|
| 1. Flange locknut (3/8 inch) | 3. Flange-head bolt (3/8 x 1-1/2 inches) |
| 2. Connect the chains through the 6th link from the tow-stop bracket on each chain | 4. Short drawbar chains |

- Torque the 5/16 inch flange-head bolts and locknuts to 19.8 to 25.4 N·m (175 to 225 in-lb).
- Torque the 3/8 flange-head bolt and locknut to 37 to 45 N·m (27 to 33 ft-lb).

Assembling the Rear Attachment Lift Cylinder

1. Remove the cable tie that secures the rear hydraulic cylinder and hoses to the back of the machine.
2. Remove the carriage bolt and flange locknut that secures the cylinder pin to the lift-shaft arm (Figure 16).

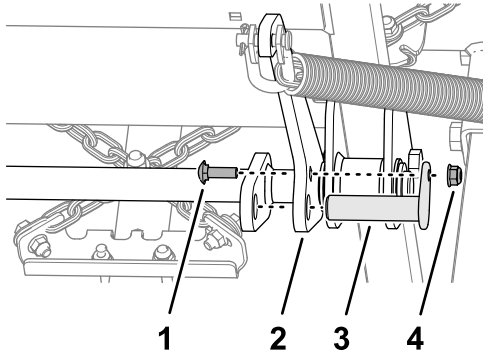

Figure 16

g361587

- | | |
|-------------------|-------------------|
| 1. Carriage bolt | 3. Cylinder pin |
| 2. Lift-shaft arm | 4. Flange locknut |

5. Assemble the rear attachment lift cylinder onto the mount shaft of the rear frame (Figure 18).

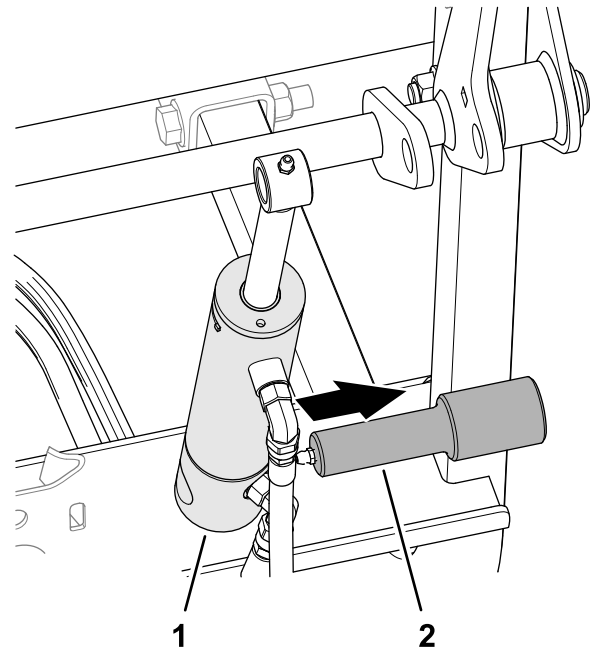

Figure 18

g374125

- | | |
|-----------------------------|-----------------------------|
| 1. Attachment-lift cylinder | 2. Mount shaft (rear frame) |
|-----------------------------|-----------------------------|

3. Route the cylinder and hoses to the back of the lift frame (Figure 17).
4. Install the hose guard around the hoses 9 cm (3.5 inches) from the rear tube channel as shown in Figure 17.

Important: Ensure that the extend and retract hoses are not twisted around each other.

If the hoses are twisted, loosen the hoses at the bulkhead side and alleviate hose twist, then torque them again.

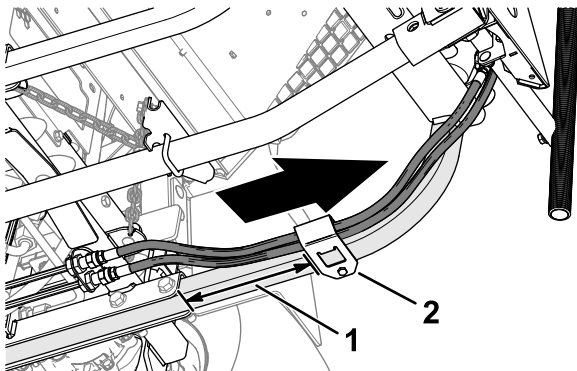
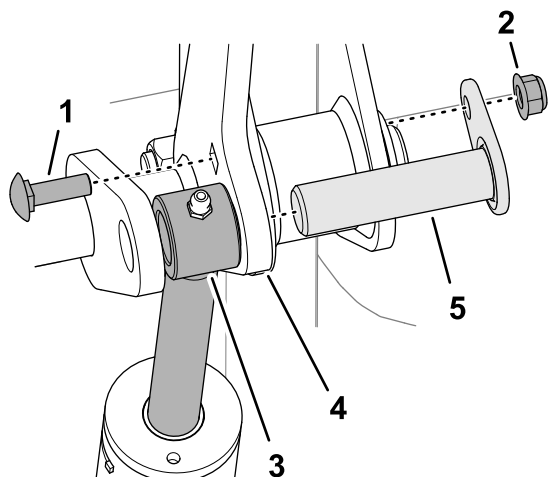

Figure 17

g361588

- | | |
|-------------------------------------------------------------|---------------|
| 1. 9 cm (3.5 inches) from the end of the rear tube channel. | 2. Hose guard |
|-------------------------------------------------------------|---------------|

- Align the rod end of the cylinder between the lift-shaft arms ([Figure 19](#)).



g374126

Figure 19

- | | |
|---------------------------------------|-------------------|
| 1. Carriage bolt | 4. Lift-shaft arm |
| 2. Flange locknut | 5. Cylinder pin |
| 3. Rod end (attachment-lift cylinder) | |

-
- Secure the rod end to the lift-shaft arms with the cylinder pin, carriage bolt, and flange locknut.
 - Grease the attachment-lift cylinder before first operation; refer to [Greasing the Bearings and Bushings \(page 49\)](#).
 - Lower the operator's platform.

Note: When the rear attachment-lift cylinder is fully extended, the drawbar should be fully raised against the rubber bumper.

Product Overview

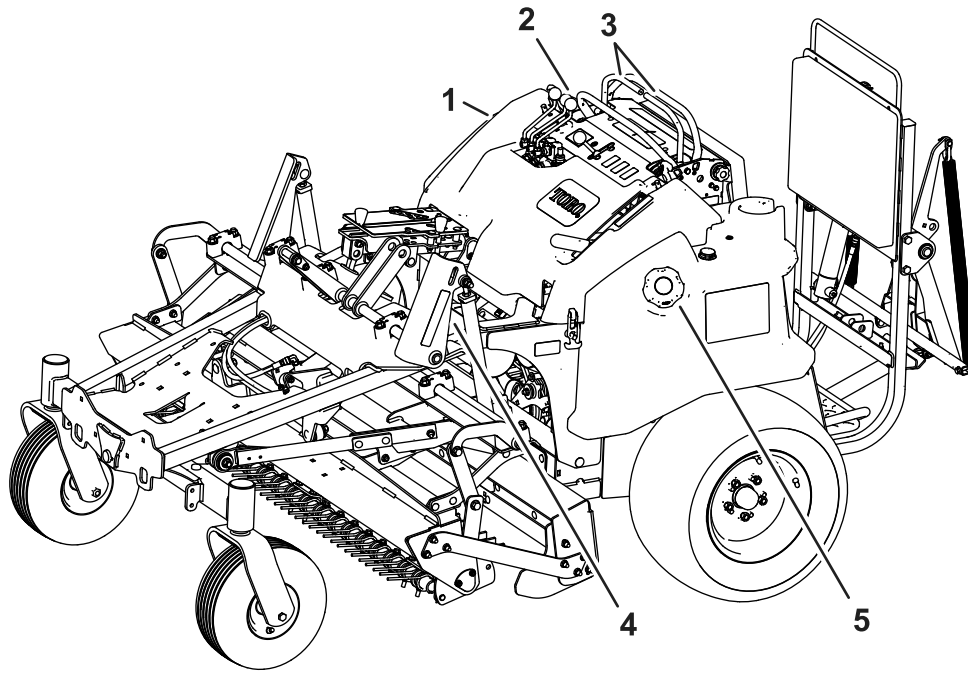

g384037

Figure 20

- 1. Hood
- 2. Attachment-lift controls
- 3. Traction controls
- 4. Mid-mount attachment lift arm
- 5. Fuel tank and cap

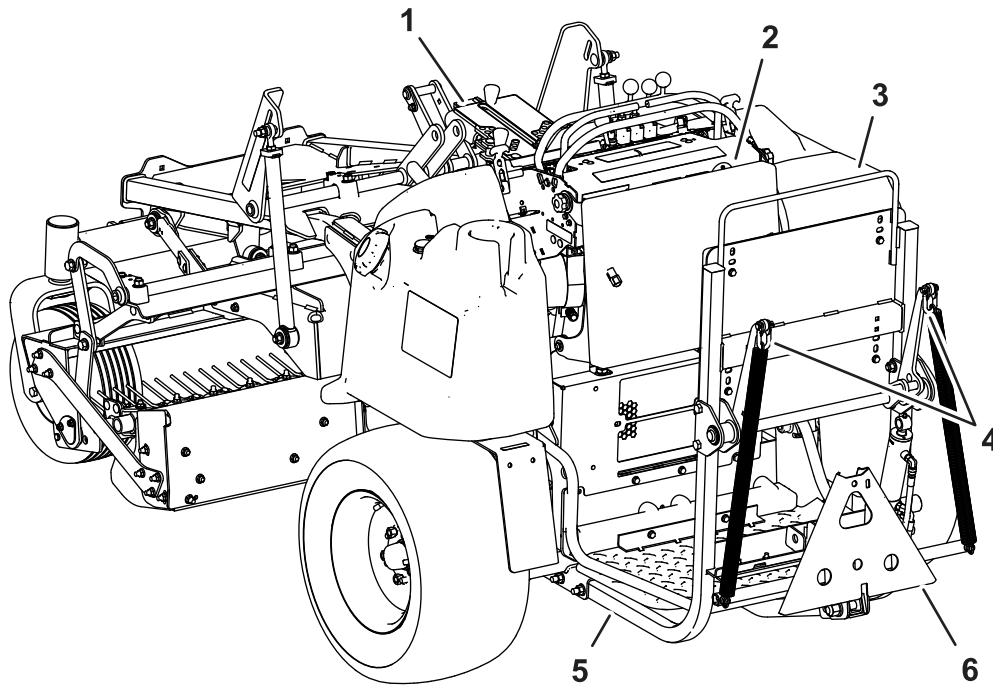

g384038

Figure 21

- 1. Depth plate (mid-mount attachment)
- 2. Cushion
- 3. Backrest
- 4. Rear attachment lift arms
- 5. Operator's platform
- 6. Rear attachment adapter

Controls

Engine and Attachment Controls

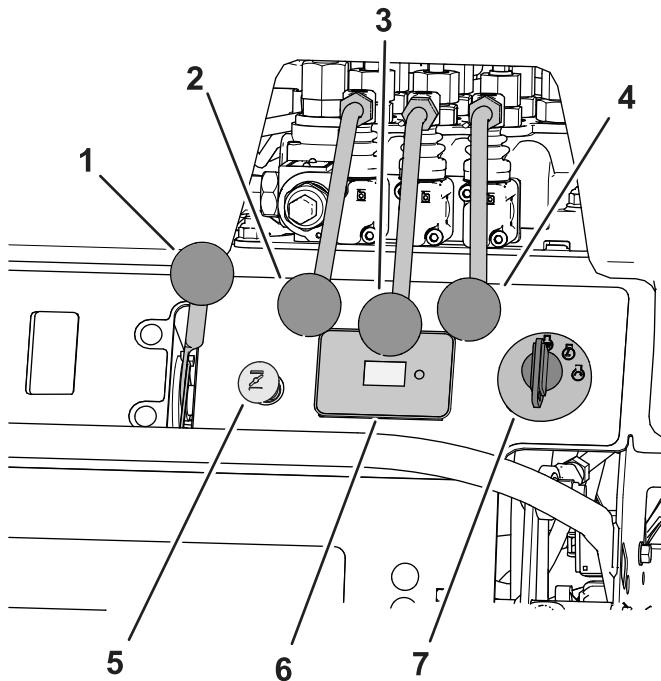

Figure 22

g384032

- | | |
|--------------------------------------|----------------------------|
| 1. Throttle lever | 5. Engine choke |
| 2. Mid-mount attachment lift control | 6. Hour meter/controller |
| 3. Mid-mount attachment tilt control | 7. Ignition key and switch |
| 4. Rear attachment lift control | |

Mid-Mount Attachment Tilt Control

Use the mid-mount attachment tilt control to adjust the engagement angle of the mid-mount attachment.

Mid-Mount Attachment Lift Control

Use the mid-mount attachment lift control to raise or lower the mid-mount attachment.

Choke Control

Use the choke control (Figure 22) to adjust the choke position for cold-engine starting.

Hour Meter/Controller

The hour meter and controller (Figure 22) performs the following functions:

- Displays the total hours of engine operation.
- Provides control for the safety interlock system and displays indicators for the following components:
 - Parking brake is in the ENGAGED position.
 - Motion controls are in the NEUTRAL position.
 - Operator is standing on the operator's platform.
- Indicates the voltage and low charging-system operation.

Ignition Key and Switch

Use the ignition switch to start and shut off the engine.

Throttle Lever

Use the throttle lever (Figure 22) to control the engine speed.

Rear Attachment Lift Control

Use the rear attachment lift control to raise or lower an optional rear installed attachment.

Parking Brake and Motion Control

Specifications

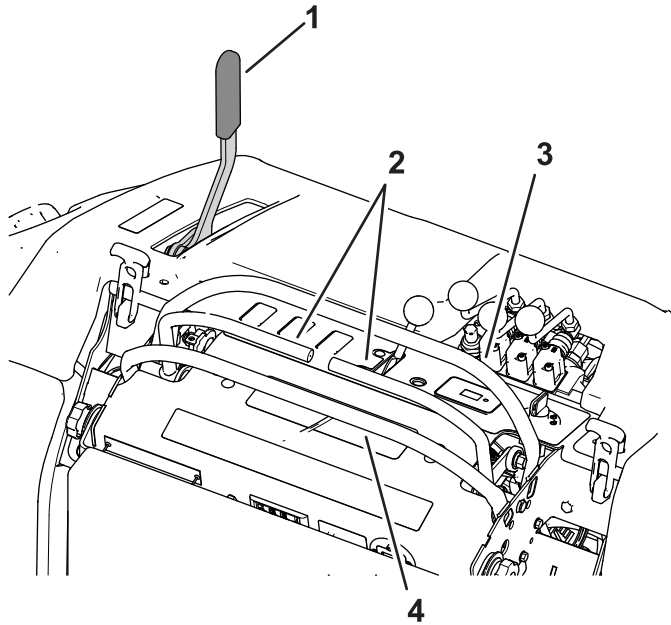

Length	292.3 cm (115 inches)
Width (without mid-mount attachment installed)	147.3 cm (58 inches)
Width (with multi-tool attachment installed)	172.7 cm (68 inches)
Height	129.5 cm (51 inches)
Net weight (empty with no options installed)	521.6 kg (1,150 lbs)
Net weight (with multi-tool attachment installed)	734.8 kg (1,620 lbs)
Maximum forward speed	16 km/h (10 mph)
Maximum reverse speed	8 km/h (5 mph)

Figure 23

g384036

- 1. Parking brake handle
- 2. Motion-control bars
- 3. Front reference bar
- 4. Rear reference bar

Parking-Brake Handle

Use the parking brake handle (Figure 23) to engage and disengage the parking brake.

The parking-brake handle is located on the control tower, to the left of the front reference bar.

Motion-control bars

The motion-control levers (Figure 23) are located at each side of the top control tower, and control the forward and reverse motion of the machine

Move the levers forward or backward to control the drive wheel on the same side forward or reverse respectively. The wheel speed is proportional to the amount you move the lever.

Operation

Before Operation

Before Operation Safety

General Safety

- Never allow children or untrained people to operate or service the machine. Local regulations may restrict the age of the operator. The owner is responsible for training all operators and mechanics.
- Become familiar with the safe operation of the equipment, operator controls, and safety signs.
- Park the machine on a level surface; engage the parking brake, lower the attachments to the ground, shut off the engine, remove the key, and wait for all movement to stop before leaving the machine.
- Know how to stop the machine and engine quickly.
- Check that any installed operator-presence controls, safety switches, and shields are attached and functioning properly. Do not operate the machine unless they are functioning properly.
- Before operating, always inspect the machine to ensure that the components and hardware are in good working condition. Replace worn or damaged components and hardware.

Fuel Safety

- Fuel is extremely flammable and highly explosive. A fire or explosion from fuel can burn you and others and can damage property.
 - To prevent a static charge from igniting the fuel, place the container and/or machine directly on the ground before filling, not in a vehicle or on an object.
 - Fill the fuel tank outdoors, in an open area, when the engine is cold. Wipe up any fuel that spills.
 - Do not handle fuel when smoking or around an open flame or sparks.
 - Do not remove the fuel cap or add fuel to the tank while the engine is running or hot.
 - If you spill fuel, do not attempt to start the engine. Avoid creating a source of ignition until the fuel vapors have dissipated.
 - Store fuel in an approved container and keep it out of the reach of children.
- Fuel is harmful or fatal if swallowed. Long-term exposure to vapors can cause serious injury and illness.

- Avoid prolonged breathing of vapors.
- Keep your hands and face away from the nozzle and the fuel-tank opening.
- Keep fuel away from your eyes and skin.
- Do not store the machine or fuel container where there is an open flame, spark, or pilot light, such as on a water heater or on other appliances.
- Do not fill containers inside a vehicle or on a truck or trailer bed with a plastic liner. Always place containers on the ground, away from your vehicle before filling.
- Remove the equipment from the truck or trailer and refuel it while it is on the ground. If this is not possible, then refuel from a portable container rather than a fuel-dispenser nozzle.
- Do not operate the machine without the entire exhaust system in place and in proper working condition.
- Keep the fuel-dispenser nozzle in contact with the rim of the fuel tank or container opening at all times until fueling is complete. Do not use a nozzle lock-open device.
- If you spill fuel on your clothing, change your clothing immediately. Wipe up any fuel that spills.
- Never overfill the fuel tank. Replace the fuel cap and tighten it securely.

Fueling the Machine

Fuel Specification

Petroleum fuel	Use unleaded gasoline with an octane rating of 87 or higher ((R+M)/2 rating method).
Ethanol blended fuel	Use an unleaded-gasoline blend with up to 10% ethanol (gasohol) or 15% MTBE (methyl tertiary butyl ether) by volume is acceptable. Ethanol and MTBE are not the same. Gasoline with 15% ethanol (E15) by volume is not approved for use. Never use gasoline that contains more than 10% ethanol by volume, such as E15 (contains 15% ethanol), E20 (contains 20% ethanol), or E85 (contains up to 85% ethanol). Using unapproved gasoline may cause performance problems and/or engine damage which may not be covered under warranty.

Important: For best results, use only clean, fresh fuel (less than 30 days old).

- Do not use gasoline containing methanol.
- Do not store fuel either in the fuel tank or fuel containers over the winter unless you use a fuel stabilizer.
- Do not add oil to gasoline.

Using Stabilizer/Conditioner

Always use fuel stabilizer/conditioner in the machine to keep the fuel fresh longer.

Important: Do not use fuel additives containing methanol or ethanol.

Add the amount of fuel stabilizer/conditioner to fresh fuel as directed by the fuel-stabilizer manufacturer.

Filling the Fuel Tank

Fuel Tank Capacity: 31.4 L (8.3 US gal)

1. Park the machine on a level surface, engage the parking brake, shut off the engine, and remove the key.

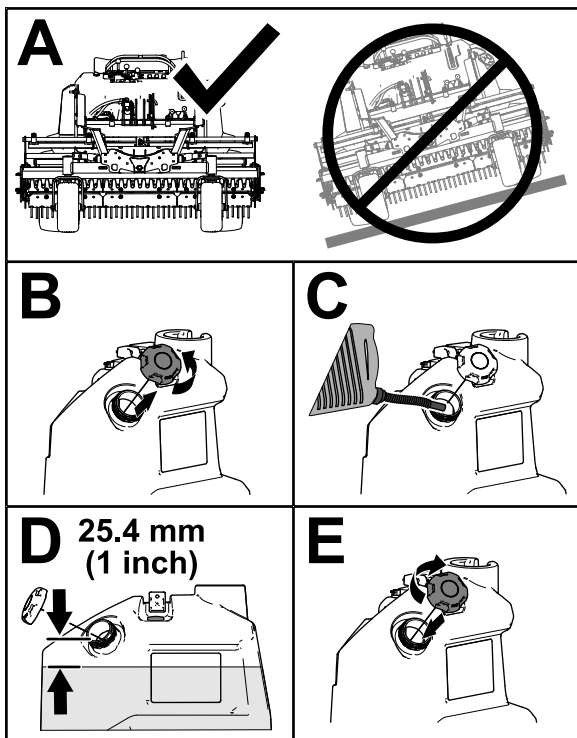

Figure 24

g334006

2. Clean around the fuel-tank cap, and remove it.
3. Fill the fuel tank to 25 mm (1 inch) below the filler neck.

Note: Do not fill the fuel tank completely full. The empty space in the tank allows the fuel to expand.

4. Assemble the fuel-tank cap to the filler neck of the tank.

Before Operations Checks

Perform the following daily procedures before operating the machine:

- [Checking the Engine-Oil Level \(page 50\)](#)
- [Checking the Tire Air Pressure \(page 57\)](#)
- [Checking the Hydraulic Lines and Hoses \(page 59\)](#)
- [Checking the Hydraulic-Fluid Level \(page 59\)](#)

Checking the Safety-Interlock System

Service Interval: Before each use or daily

Checking the Parking Brake-Interlock Switches

1. Stand on the operator's platform.
2. Disengage the parking brake.
3. Move the motion-control bars to the NEUTRAL position.
4. Try starting the engine.

Important: The engine should not start. If the engine starts, shut off the engine, remove the key, and contact you authorized Toro distributor for service.

Checking the Motion Control-Interlock Switches

1. Stand on the operator's platform.
2. Engage the parking brake.
3. Move the left motion-control bar to the FORWARD position.
4. Try starting the engine.
5. Move the right motion-control bar to the FORWARD position.
6. Try starting the engine.

Important: The engine should not start. If the engine starts, shut off the engine, remove the key, and contact you authorized Toro distributor for service.

Checking the Operators Platform-Interlock Switches

Important: The operators platform-interlock switches are included with some attachment kits; they are not included on the base machine.

1. Engage the parking brake.
2. Move the motion-control bars to the NEUTRAL position.
3. Step off the operator's platform, and stand on the ground.
4. Try starting the engine.

Important: The engine should not start. If the engine starts, shut off the engine, remove the key, and contact your authorized Toro distributor for service.

Adjusting the Backrest Position

1. Remove the 4 bolts and 4 washers that secure the backrest pad to the mounting plate (Figure 25).

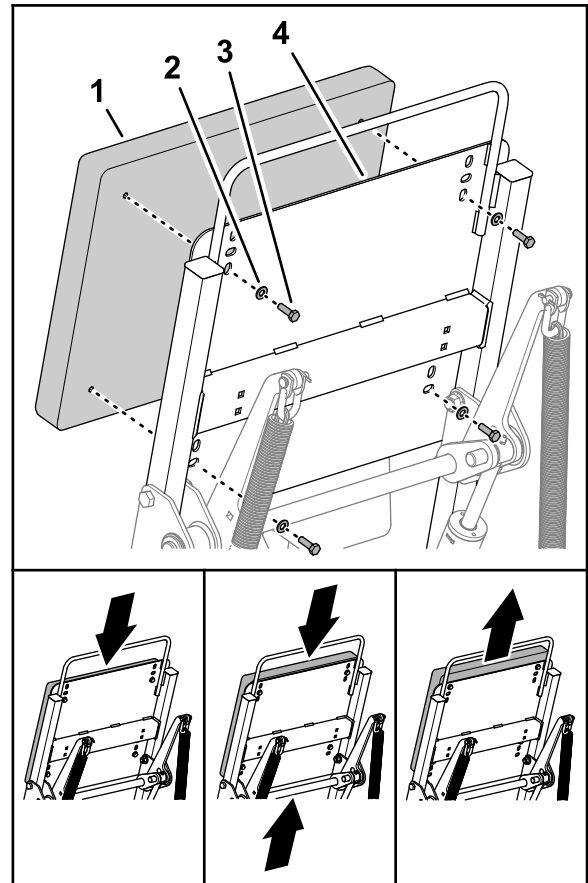

Figure 25

g359257

- | | |
|-----------------|-------------------|
| 1. Backrest pad | 3. Bolt |
| 2. Washer | 4. Mounting plate |

2. Raise or lower the backrest pad.
3. Align the hole in the backrest pad with the holes in the mounting plate.
4. Secure the pad to the plate with the 4 bolts and 4 washers.

During Operation

During Operation Safety

General Safety

- The owner/operator can prevent and is responsible for accidents that may cause personal injury or property damage.
- Wear appropriate clothing, including eye protection; long pants; substantial, slip-resistant footwear; and hearing protection. Tie back long hair and do not wear loose clothing or loose jewelry.
- Use your full attention while operating the machine. Do not engage in any activity that causes distractions; otherwise, injury or property damage may occur.
- Do not operate the machine while ill, tired, or under the influence of alcohol or drugs.
- Never carry passengers on the machine and keep bystanders and pets away from the machine during operation.
- Operate the machine only in good visibility and appropriate weather conditions. Do not operate the machine when there is the risk of lightning.
- Operate the machine only in good visibility to avoid holes or hidden hazards.
- Before you start the engine, ensure that all drives are in neutral, the parking brake is engaged, and you are in the operating position.
- Look behind and down before backing up to be sure of a clear path.
- Use extreme care when approaching blind corners, shrubs, trees, or other objects that may block your view.
- Stop the machine and inspect the attachment after striking an object or if there is an abnormal vibration in the machine. Make all necessary repairs before resuming operation.
- Slow down and use caution when making turns and crossing roads and sidewalks with the machine. Always yield the right-of-way.
- Operate the engine only in well-ventilated areas. Exhaust gases contain carbon monoxide, which is lethal if inhaled.
- Never leave a running machine unattended.
- Before leaving the operating position, do the following:
 - Park the machine on level ground.
 - Lower the attachments.
 - Engage the parking brake.

- Shut off the engine and remove the ignition key.
- Wait for all moving parts to stop.

- Do not operate the machine when there is the risk of lightning.
- Do not use the machine as a towing vehicle without the Toro-approved hitch kit.
- When necessary, wet surfaces prior to conditioning to minimize dust creation.
- Use accessories, attachments, and replacement parts approved by The Toro® Company only.

Slope Safety

- Establish your own procedures and rules for operating on slopes. These procedures must include surveying the site to determine which slopes are safe for machine operation. Always use common sense and good judgment when performing this survey.
- Slopes are a major factor related to loss of control and rollover accidents, which can result in severe injury or death. The operator is responsible for safe slope operation. Operating the machine on any slope requires extra caution.
- Slopes are a major factor related to loss-of-control and tip-over accidents, which can result in severe injury or death. Operating the machine on any slope requires extra caution.
- Operate the machine at a lower speed when you are on a slope.
- If you feel uneasy operating the machine on a slope, do not do it.
- Watch for holes, ruts, bumps, rocks, or other hidden objects. Uneven terrain could overturn the machine. Tall grass can hide obstacles.
- Choose a low ground speed so you will not have to stop or shift while on a slope.
- A rollover can occur before the tires lose traction.
- Avoid operating the machine on wet grass. Tires may lose traction; regardless if the brakes are available and functioning.
- Avoid starting, stopping, or turning the machine on a slope.
- Keep all movement on slopes slow and gradual. Do not suddenly change the speed or direction of the machine.
- Do not operate the machine near drop-offs, ditches, embankments, or bodies of water. The machine could suddenly roll over if a wheel goes over the edge or the edge caves in. Establish a safety area between the machine and any hazard (2 machine widths).

Operating the Parking Brake

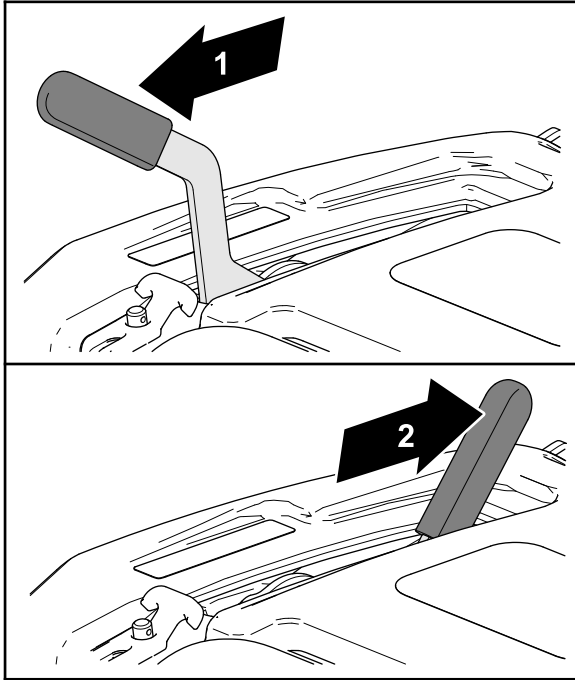

Figure 26

g333764

1. Parking brake engaged 2. Parking brake disengaged

- Pull the parking brake handle to engage the parking brake (Figure 26).
- Push the parking brake handle to disengage the parking brake.

Starting the Engine

Important: Do not engage starter for more than 5 seconds at a time. If the engine fails to start, wait 15 seconds between attempts. Failure to follow these instructions can burn out the starter motor.

Note: You may need multiple attempts to start the engine the first time after adding fuel to an empty fuel system.

1. Move the motion-control bars to the NEUTRAL position.
2. Engage the parking brake.
3. Move the throttle midway between the SLOW and FAST positions (Figure 27).

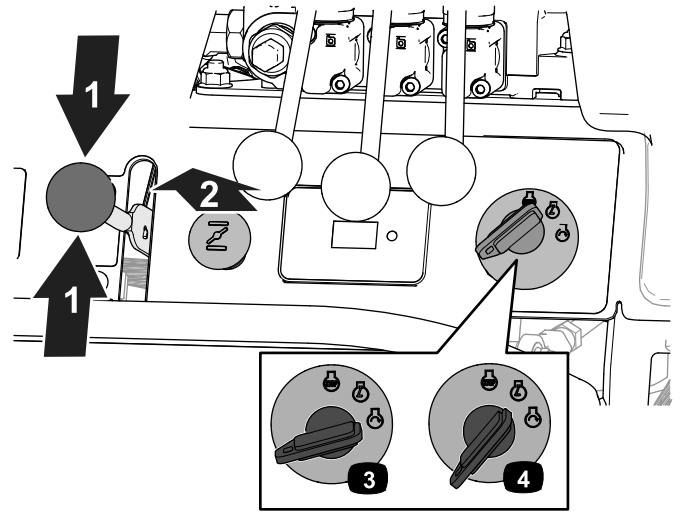

Figure 27

g384035

1. Throttle—midway position 3. Ignition key—START
2. Choke—ON 4. Ignition key—RUN

4. If the engine is cold, pull the choke control to the ON position (Figure 27).

Note: When operating the machine in temperatures less than 0°C (32°F) allow the engine time to warm up before using the machine. This prevents damage to the hydraulic system.

5. Rotate the ignition key to the START position (Figure 27).

Note: To prevent overheating the starter motor, do not engage the starter longer than 10 seconds. After continuous cranking the starter for 10 seconds, wait 60 seconds before engaging the starter motor again.

6. When the engine starts, rotate the key to the RUN position (Figure 27).
7. Move the throttle to the SLOW position, and allow the engine to warm.
8. As the engine warms up, push the choke control toward the OFF position (Figure 27).

Shutting Off the Engine

Important: Always remove the key and engage the parking brake when leaving the machine unattended.

1. Move the motion-control bars to the NEUTRAL position.
2. Engage the parking brake.
3. Lower the attachments.
4. Move the throttle to the SLOW position ([Figure 28](#)).

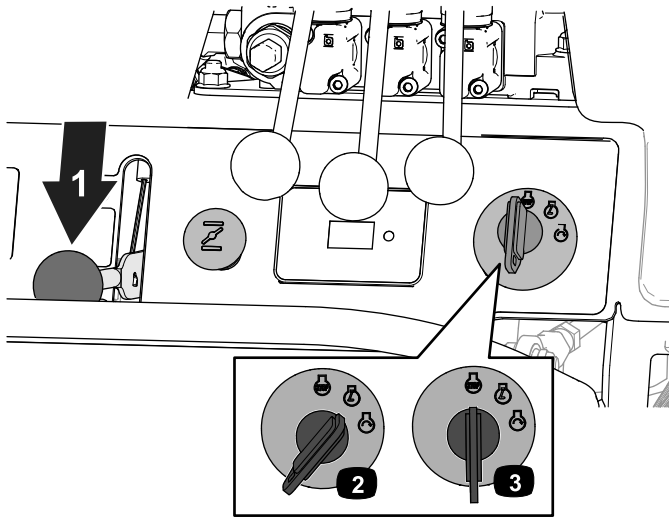

g384034

Figure 28

- | | |
|---------------------|----------------------|
| 1. Throttle—SLOW | 3. Ignition key—STOP |
| 2. Ignition key—RUN | |
-
5. Rotate the ignition key to the STOP position ([Figure 28](#)).
 6. Remove the key and wait for all moving parts to stop before leaving the operator's position.

Driving the Machine

⚠ CAUTION

Machine can spin very rapidly by positioning 1 lever too much ahead of the other. You may lose control of the machine, which may cause damage to the machine or injury.

- Use caution when making turns.
- Slow the machine down before making sharp turns.

Driving Forward

Note: The engine shuts off if you move the motion-control bars with the parking brake engaged.

1. Move the motion-control bars to the NEUTRAL position.
2. Disengage the parking brake; refer to [Operating the Parking Brake \(page 24\)](#).
3. To drive the machine forward, perform the following:

Note: The machine moves faster the farther the motion-control levers are moved from the NEUTRAL position.

- To move forward in a straight line, move both motion-control bars forward at the same time.

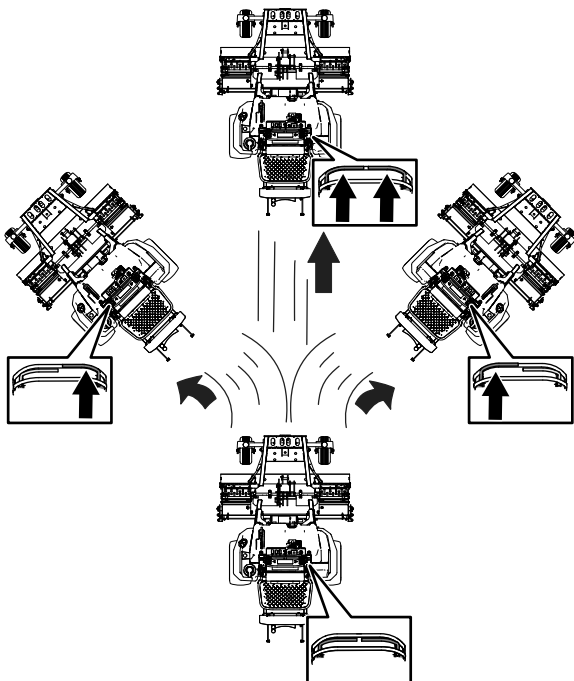

Figure 29

g334482

- To turn left or right, pull the motion-control bar back toward neutral in the desired turn direction.
- To stop the machine, move both motion-control bars to the NEUTRAL position.

Driving Backward

1. Move the motion-control bars to the NEUTRAL position.
2. Raise the mid-mount attachment and optional rear attachment.
3. To drive the machine backward, perform the following:

Note: The machine moves faster the farther the motion-control levers are moved from the NEUTRAL position.

- To move backward in a straight line, move both motion-control bars backward at the same time.

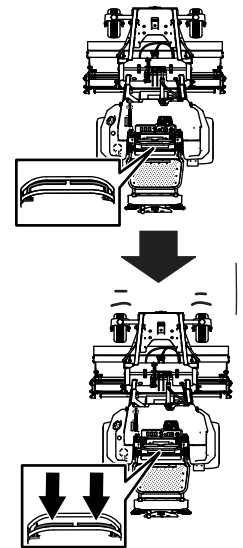

Figure 30

g334481

- To turn left or right, release pressure on the motion-control bar toward the desired turn direction.
- To stop the machine, move both motion-control bars to the NEUTRAL position.

Adjusting the Height of the Mid-Mount Attachment

Raising the Mid-Mount Attachment

1. Park the machine on a level surface and engage the parking brake.
2. If you want to fully raise the mid-mount attachment remove the stop pin from the up-stop attachment-stop hole, and insert it into the stow attachment-stop hole; refer to [Mid-Mount Attachment Stop](#) (page 31).
3. With the engine running, pull back the mid-mount attachment lift control to raise the mid-mount attachment([Figure 31](#)).

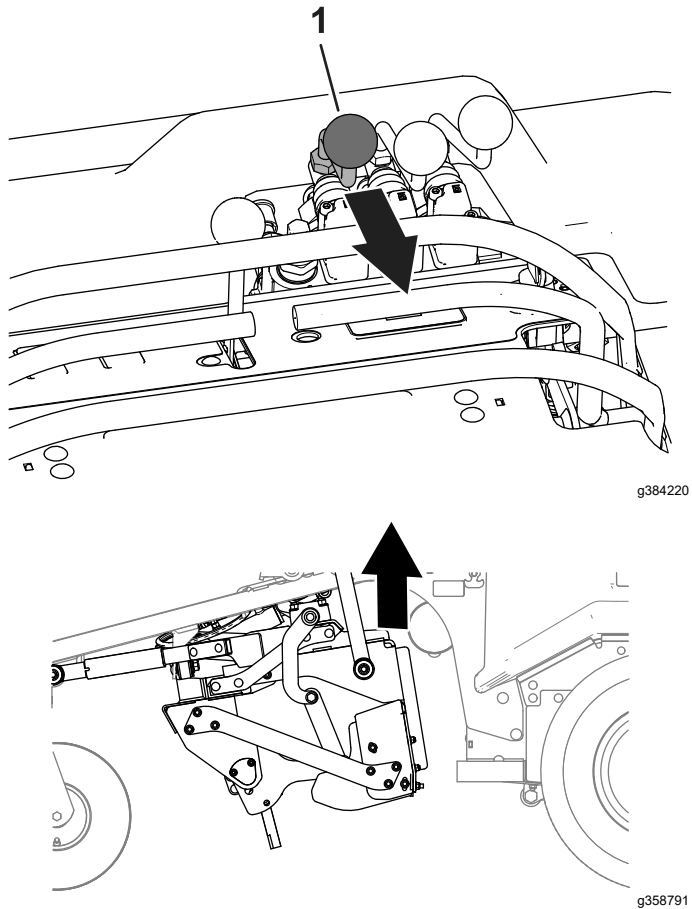

Figure 31

1. Mid-mount attachment control

Lowering the Mid-Mount Attachment

1. Park the machine on a level surface.
2. If needed, adjust the mid-mount attachment stop depth; refer to [Using the Attachment Stop During Operation](#) (page 34).
3. With the engine running, push forward the mid-mount attachment lift control to lower the mid-mount attachment ([Figure 32](#)).

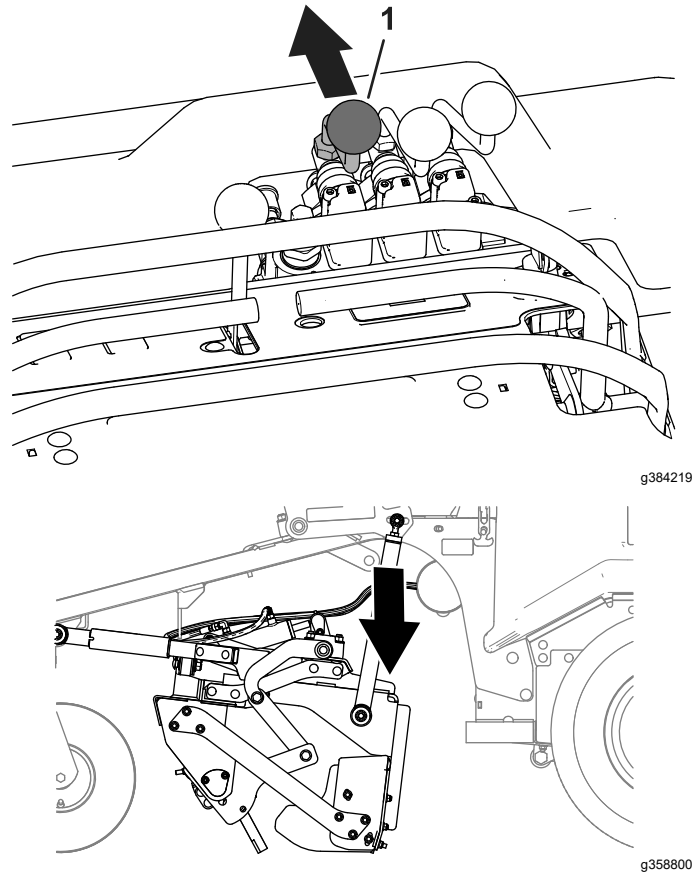

Figure 32

1. Mid-mount attachment control

Adjusting the Tilt Angle of the Mid-Mount Attachment

Tilting the Mid-Mount Attachment Backward

Move the mid-mount attachment tilt control forward to rotate the tine-engagement angle backward.

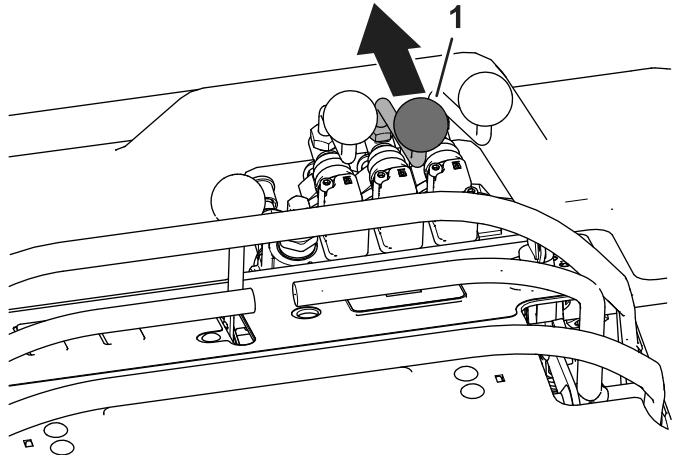

g384040

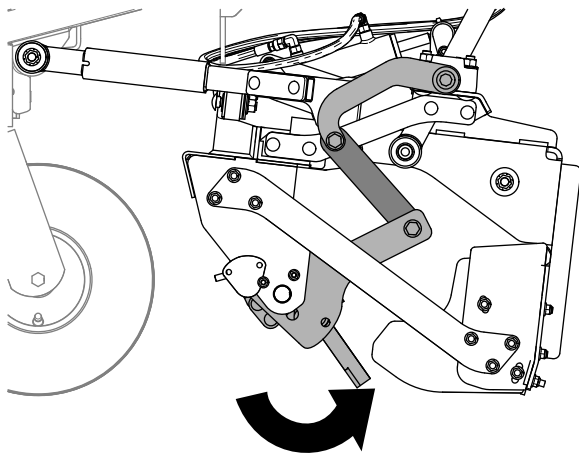

Figure 33

g359101

1. Mid-mount attachment tilt control

Tilting the Mid-Mount Attachment Forward

Move the mid-mount attachment tilt control back to rotate the tine-engagement angle forward.

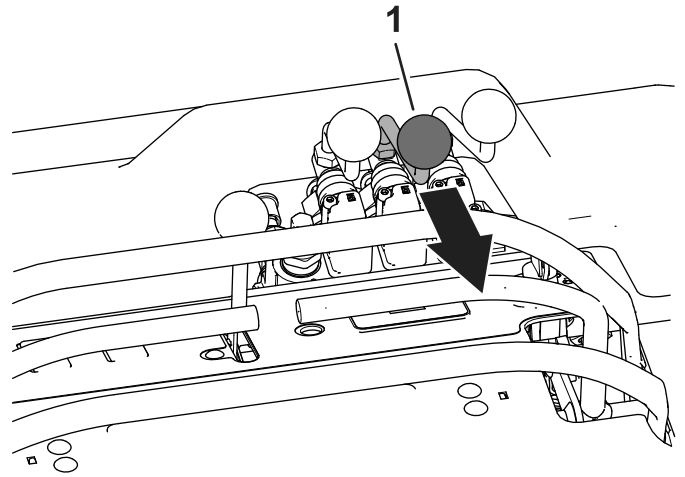

g384041

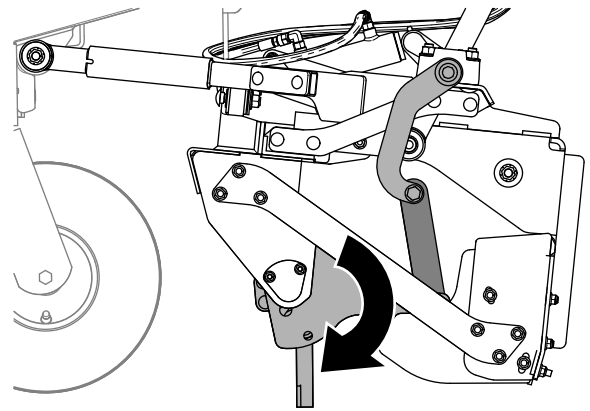

g359102

Figure 34

1. Mid-mount attachment tilt control

Selecting the Multi-Tool

1. Fully lift the multi-tool carrier; refer to [Raising the Mid-Mount Attachment \(page 27\)](#).
2. Rotate the multi-tool carrier backward until you can fully access the clevis pin and the 13 mm (1/2 inch) hole in the angle-select plate; refer to [Tilting the Mid-Mount Attachment Forward \(page 28\)](#).

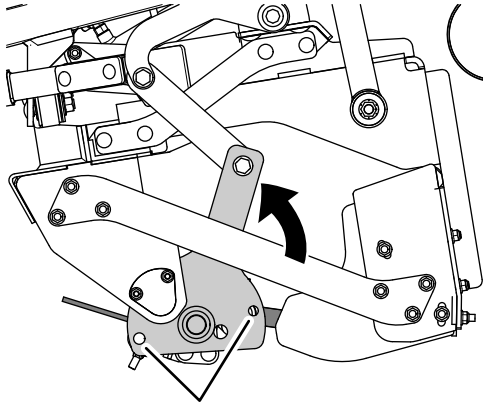

Figure 35

g365930

1. Clevis pin and hole (angle-select plate)

3. Remove the hairpin and clevis pin that secures the multi-tool arm to the angle-select plate ([Figure 36](#)).

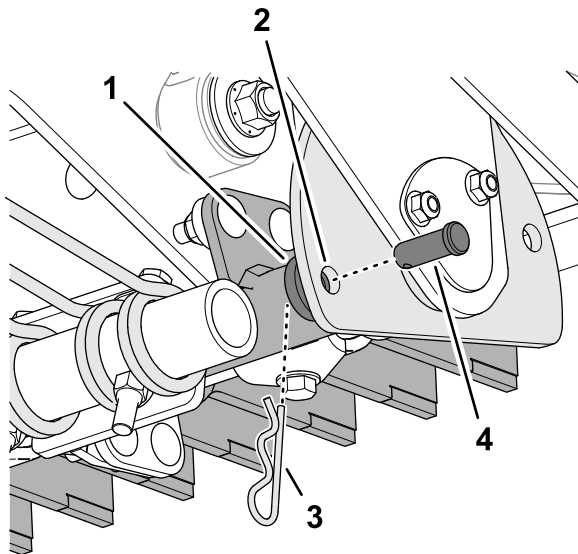

Figure 36

g359129

- | | |
|------------------------------|---------------|
| 1. Multi-tool arm | 3. Hairpin |
| 2. Hole (angle-select plate) | 4. Clevis pin |

4. Repeat step 3 at the other side of the machine.

⚠ CAUTION

The multi-tool arm rotates freely when the clevis pins are removed; your hands or fingers could get pinched and injured if they are caught between the multi-tool arm and the angle-select plate.

- Keep your hands and fingers clear of the area behind the angle-select plate while rotating the multi-tool.
- Secure multi-tool arm from movement before removing the second clevis pin.

5. Rotate the multi-tool arm to select a set of plow tines ([Figure 37](#)).

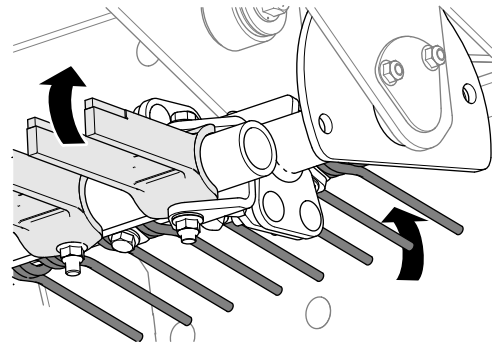

Figure 37

g359130

6. Align the hole in the multi-tool arm with the hole in the angle-select plate ([Figure 38](#)).

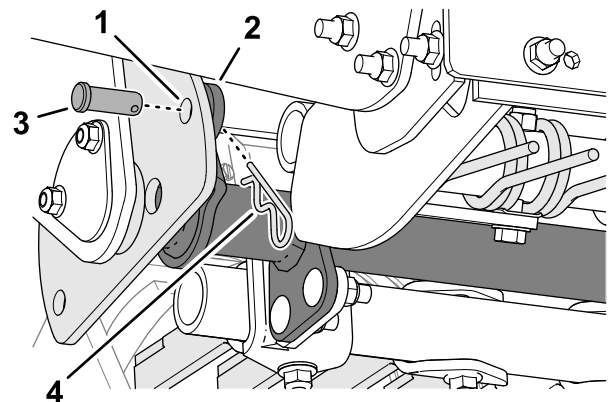

Figure 38

g359128

- | | |
|------------------------------|---------------|
| 1. Hole (angle-select plate) | 3. Clevis pin |
| 2. Multi-tool arm | 4. Hairpin |

7. Secure the multi-tool arm to the angle-select plate with the clevis pin and hairpin.
8. Repeat step 7 at the other side of the machine.

9. Adjust the tilt of the multi-tool carrier as needed (Figure 39).

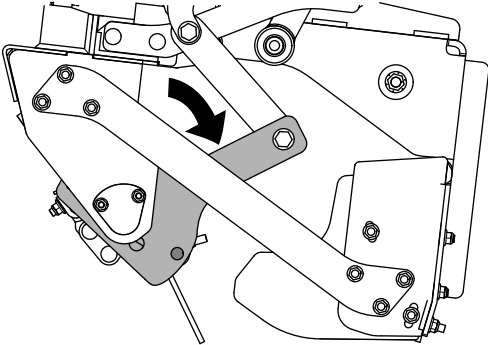

g359127

Figure 39

Mid-Mount Attachment Stop

Attachment Stop Description

Use the stop pins and the mid-mount attachment stop to limit how far up or down you can position the mid-mount attachment, when transporting the machine, and when maintaining the mid-mount attachment.

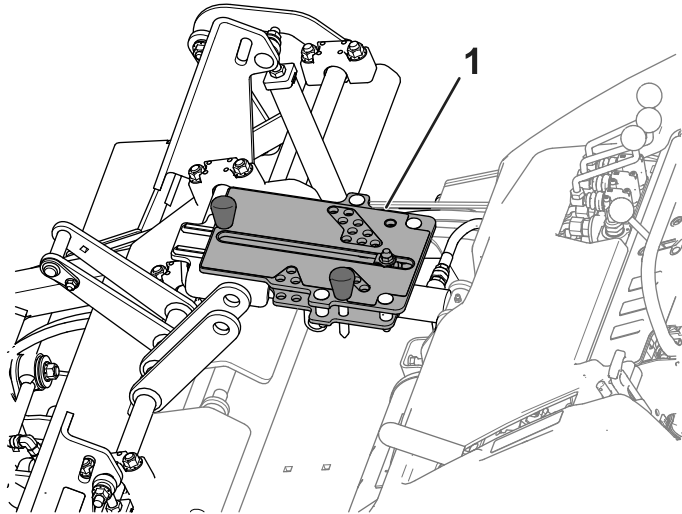

Figure 40

1. Mid-mount attachment stop

You can use a combination of stop pin positions depending on your task.

Task	Stop Pin 1	Stop Pin 2
Transporting the machine or maintaining the mid-mount attachment	Transport and maintenance position	Stow position
Limit the mid-mount attachment raised or lowered positions	Above grade position, grade position, or below grade position	Up-stop positions or stow position
Limit the mid-mount attachment lowered position	Above grade position, grade position, or below grade position	Stow position
Operate the mid-mount attachment with a full raise and lower range	Stow Position	Stow position

Transport and Maintenance Stop-Pin Position

Insert a stop pin into the transport and maintenance position attachment-stop hole when you transport the machine between job sites, or when you adjust or maintain the mid-mount attachment. The transport and maintenance position lock the mid-mount attachment at the highest position.

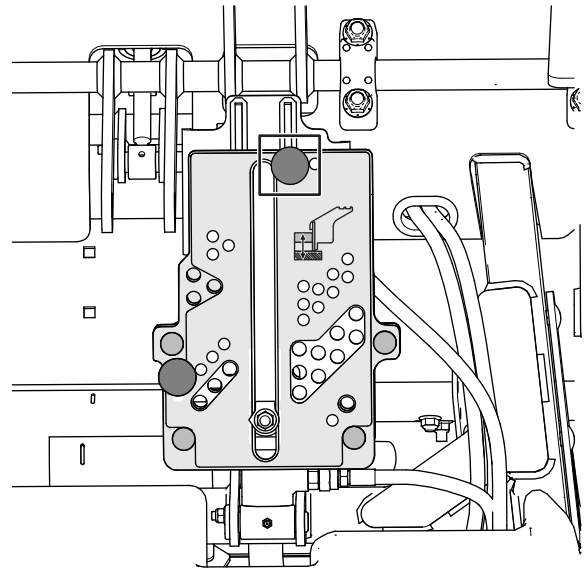

g384262

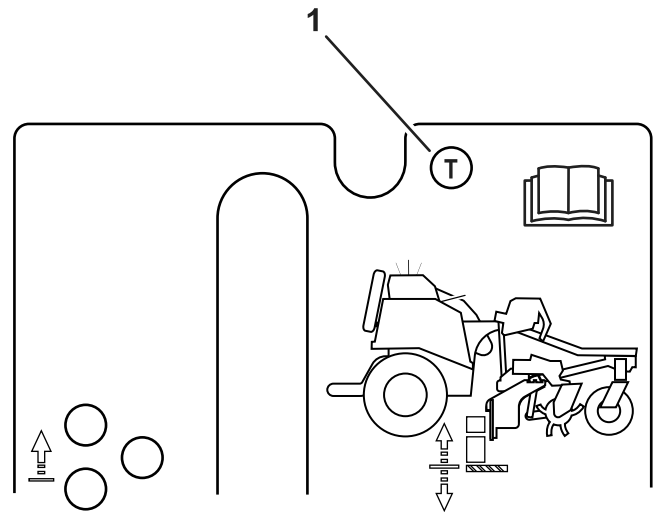

g384260

Figure 41

1. Transport and maintenance position

Up-Stop Stop-Pin Positions

Insert a stop pin into an up-stop attachment-stop hole when you want to repeatably limit how high you can raise the mid-mount attachment. The up-stop position helps speed the process of raising or lowering the attachment at the end or beginning of each working pass.

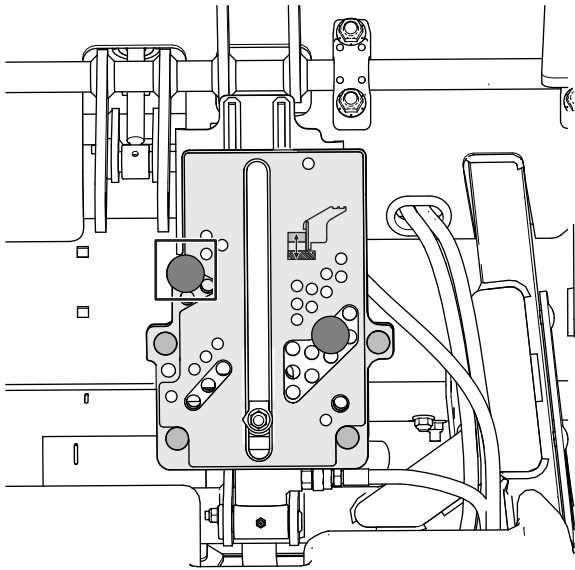

g384261

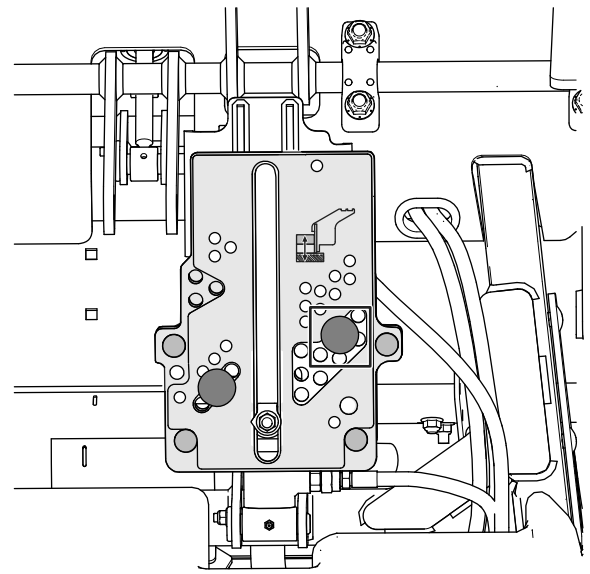

g384265

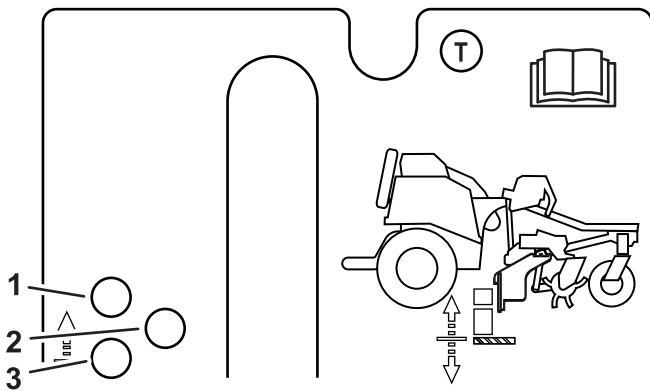

g384263

Figure 42

- | | |
|-----------------------|---------------------|
| 1. 51 mm (2.0 inches) | 3. 25 mm (1.0 inch) |
| 2. 38 mm (1.5 inches) | |

Above-Grade Stop-Pin Positions

Insert a stop pin into an above-grade attachment-stop hole when you want to repeatably lower the mid-mount attachment to a selected above-grade position.

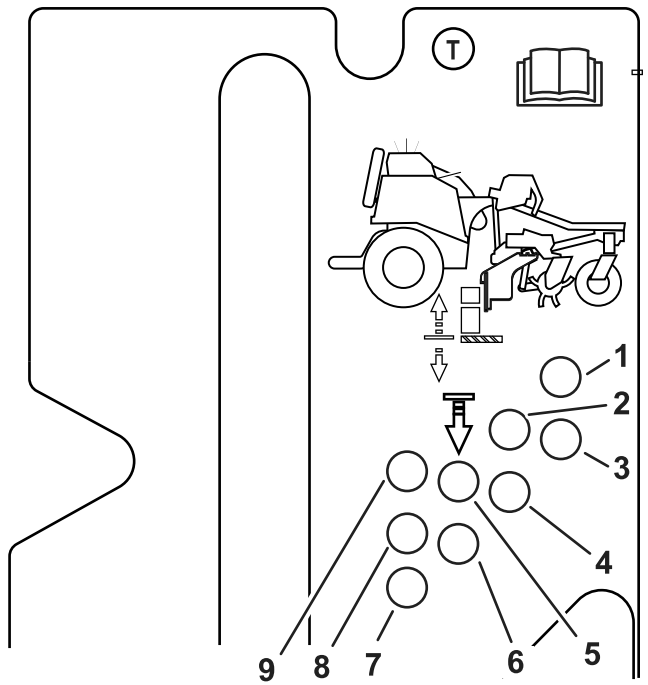

g384264

Figure 43

- | | |
|------------------------|-----------------------|
| 1. 44 mm (1.75 inches) | 6. 6 mm (0.25 inch) |
| 2. 38 mm (1.5 inches) | 7. 3 mm (0.12 inch) |
| 3. 19 mm (0.75 inch) | 8. 25 mm (1.0 inch) |
| 4. 13 mm (0.5 inch) | 9. 51 mm (2.0 inches) |
| 5. 32 mm (1.25 inches) | |

Grade- or Below-Grade Stop-Pin Positions

Insert a stop pin into a grade- or below-grade attachment-stop hole when you want to repeatably lower the mid-mount attachment to grade or a selected below-grade position.

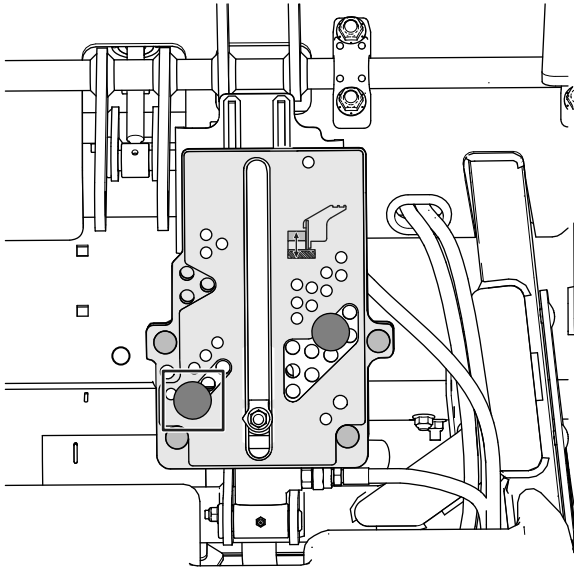

g384266

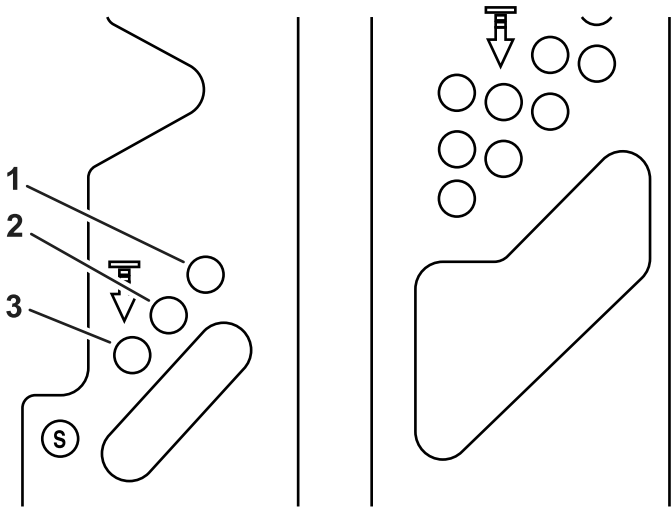

g384267

Figure 44

- 1. 0 mm (0 inch)
- 2. -3 mm (-0.12 inch)
- 3. -6 mm (-0.25 inch)

Stow Stop-Pin Positions

Insert the stop pin(s) into the stow attachment-stop hole(s) when you are not using them.

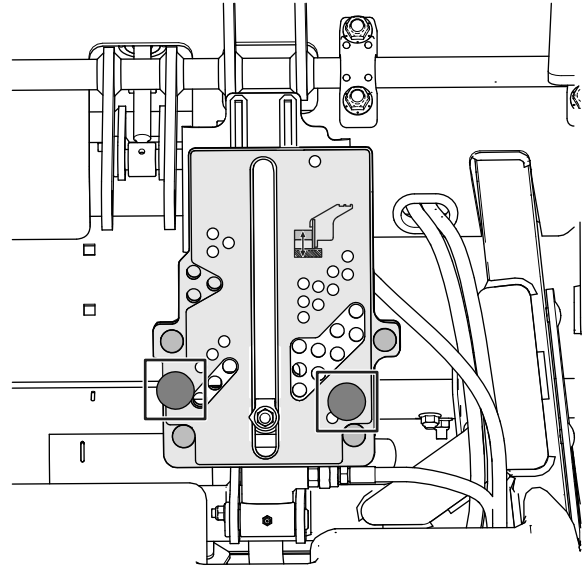

g384281

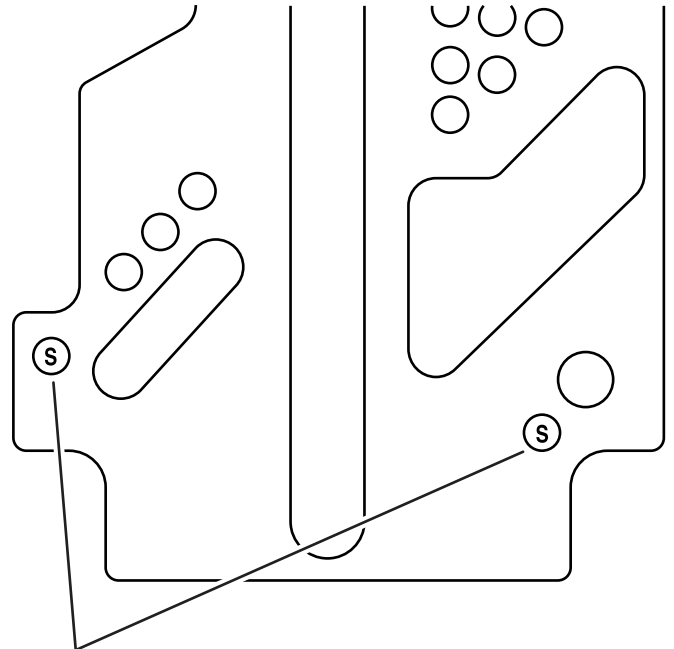

1

Figure 45

g384282

- 1. Stow positions

Using the Attachment Stop During Operation

1. If needed, calibrate the mid-mount attachment stop to grade; refer to [Calibrating Mid-Mount Attachment Stop](#) (page 36).
2. Move the machine to a level surface at the job site, and engage the parking brake.
3. Lower the mid-mount attachment [Adjusting the Height of the Mid-Mount Attachment](#) (page 27).
4. If used, insert a stop pin into the up-stop attachment-stop hole; refer to [Up-Stop Stop-Pin Positions](#) (page 32).
5. If used, raise the mid-mount attachment as needed and insert a stop pin into one of the following attachment-stop holes:
 - Above-grade attachment-stop hole ([Figure 46](#))

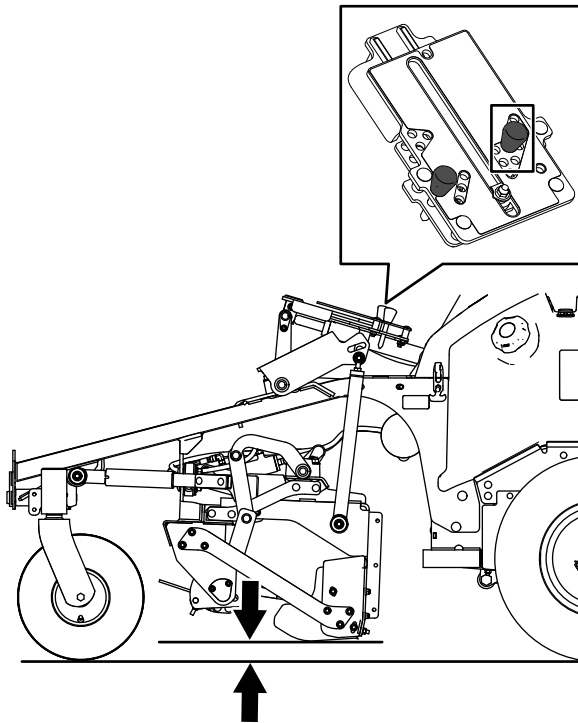

Figure 46

g384283

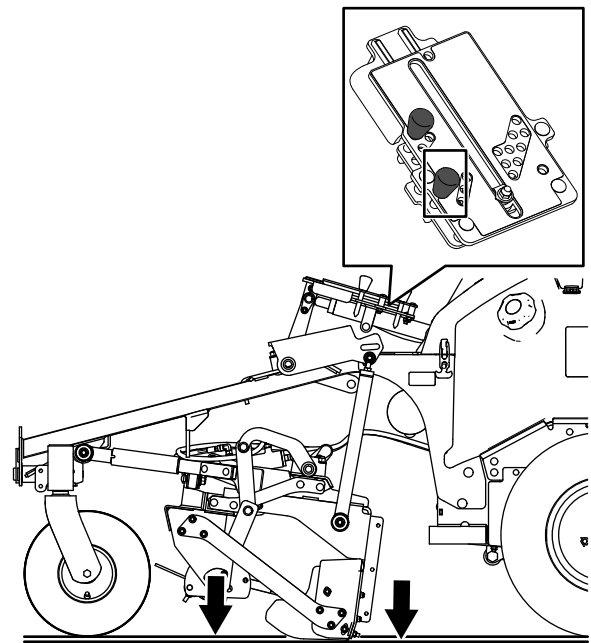

Figure 47

g384284

6. Raise or lower the mid-mount attachment until the attachment stop contacts the stop pin.

- Grade- or below-grade attachment-stop hole ([Figure 47](#))

Using the Attachment Stop for Transporting or Maintenance

1. Move the machine to a level surface at the job site, and engage the parking brake.
2. If inserted remove the stop pin from the up-stop attachment-stop hole.
3. Fully raise the mid-mount attachment.

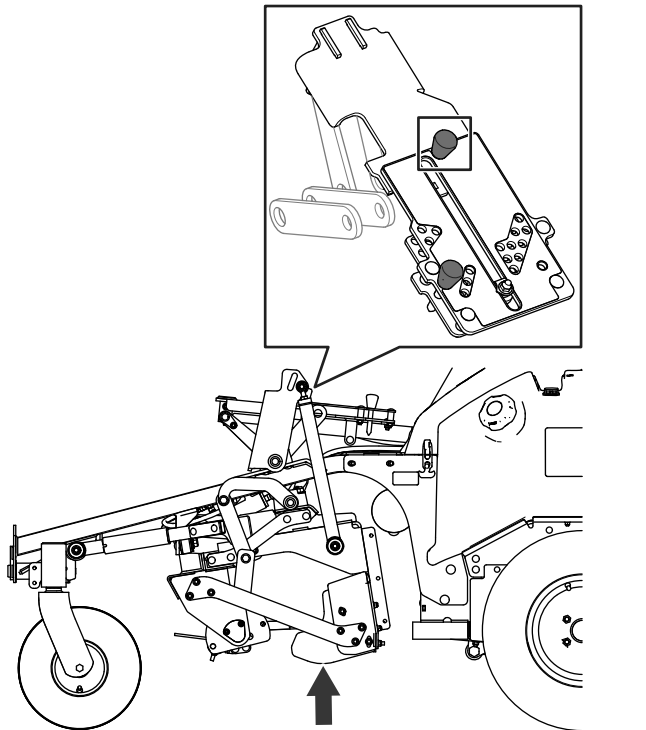

Figure 48

g384310

-
4. Insert a stop pin into the transport and maintenance position attachment-stop hole.

Calibrating Mid-Mount Attachment Stop

This procedure adjusts ground level reference point for the attachment stop.

Preparing the Machine

Optional Mid-Mount Grader

Operator supplied: 2 wood blocks 38 mm (1-1/2 inches) thick

1. Move the machine to a level surface and engage the parking brake.
2. If inserted remove the stop pins from the following mid-mount attachment stop positions:
 - Transport and maintenance position attachment-stop hole
 - Up-stop attachment-stop hole
 - Grade- or below-grade attachment-stop hole
 - Above-grade attachment-stop hole

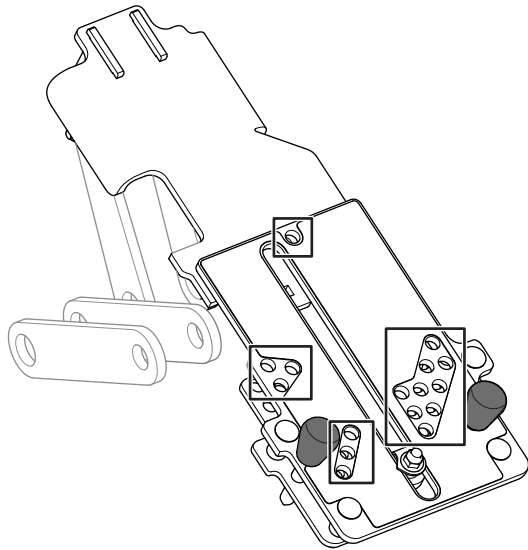

Figure 49

3. Fully raise the mid-mount attachment; refer to [Raising the Mid-Mount Attachment \(page 27\)](#).
4. Tilt the multi-tool carrier backward ([Figure 50](#)) until the tines are aligned higher than the bottom of the grader blade; refer to [Tilting the Mid-Mount Attachment Forward \(page 28\)](#).

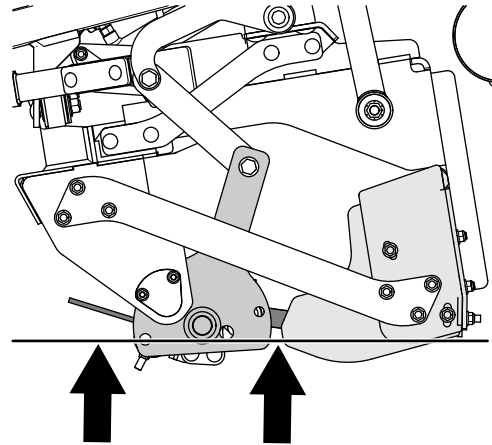

Figure 50

Positioning the Mid-Mount Attachment and Attachment Stop

1. Align a 38 mm (1.5 inches) wood block thick under each side of the mid-mount attachment.

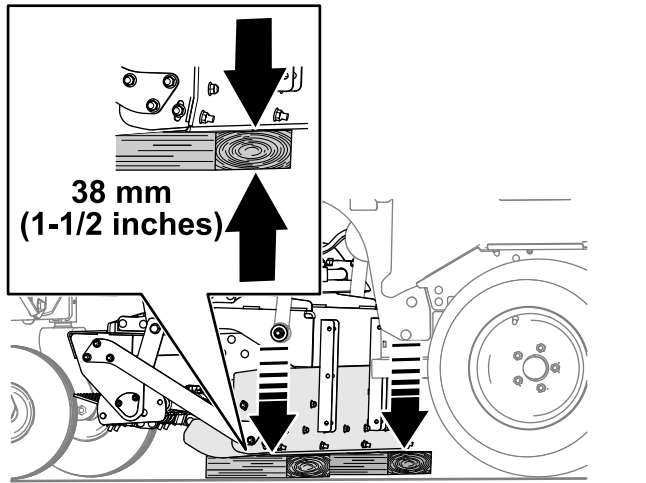

Figure 51

g379685

2. Lower the mid-mount attachment onto the wood blocks, shut off the engine, remove the key, and wait for all moving parts to stop.
3. Loosen the rod end jam nut that secures the rod end to the lift link (Figure 47).

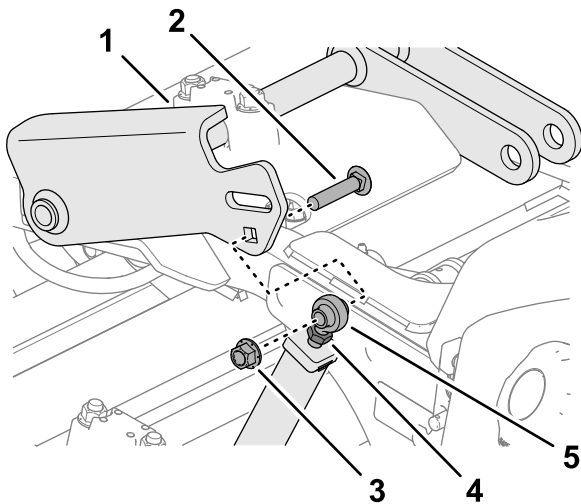

Figure 52

g379723

- | | |
|---------------------|------------------------|
| 1. Lift-arm bracket | 4. Jam nut |
| 2. Carriage bolt | 5. Rod end (lift link) |
| 3. Flange locknut | |

4. Remove the carriage bolt and locknut that secures the lift link to the lift-arm bracket, and rotate the lift link rearward.
5. Repeat steps 3 and 4 at the other side of the machine.

6. Start the engine, and move the mid-mount attachment lift control rearward until the mid-mount attachment lift cylinder is fully extended.

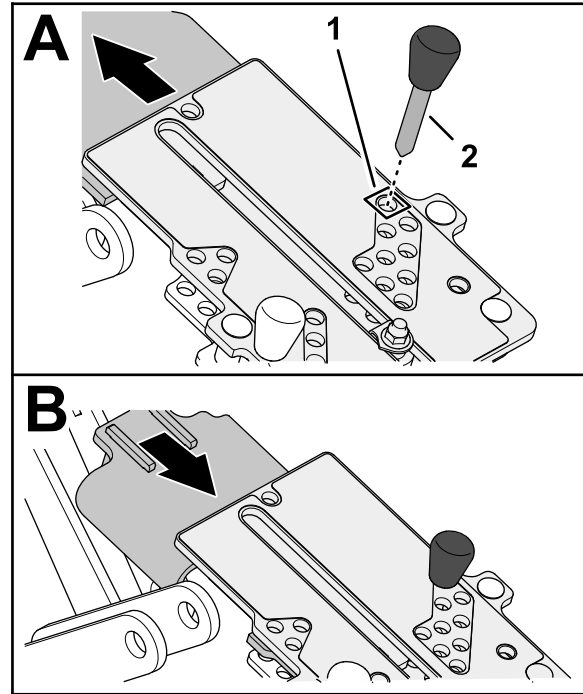

Figure 53

g384322

- | | |
|------------------------------------------------------|-------------|
| 1. 38 mm (1.5 inch) above-grade attachment-stop hole | 2. Stop pin |
|------------------------------------------------------|-------------|

7. Insert a stop pin into the 38 mm (1.5 inch) above-grade attachment-stop hole.
8. Move the mid-mount attachment lift control forward until the attachment stop contacts the stop pin.
9. Shut off the engine, remove the key, and wait for all moving parts to stop.

Adjusting the Lift Links

1. Align the lift link to the lift-arm bracket, and rotate the rod end until the hole in the rod end aligns with the hole in the lift-arm bracket.

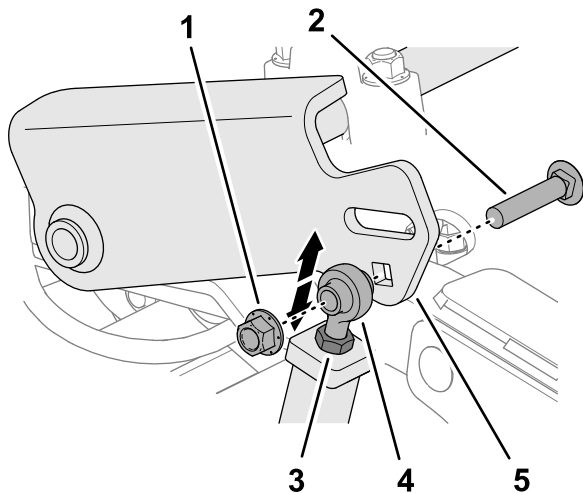

Figure 54

g365644

- | | |
|-------------------|------------------------|
| 1. Flange locknut | 4. Rod end (lift link) |
| 2. Carriage bolt | 5. Lift-arm bracket |
| 3. Jam nut | |

2. Assemble the rod end to the lift-arm bracket with the carriage bolt and locknut.
3. Tighten the jam nuts securing the rod end to the lift link to 91 to 113 N·m (67 to 83 ft-lbs).
4. Repeat steps 1 through 3 at the other side of the machine.
5. Start the engine, raise the mid-mount attachment, remove the wood blocks, and remove the stop pin from the 38 mm (1.5 inch) above-grade attachment-stop hole.
6. Fully lower the mid-mount attachment to the ground.

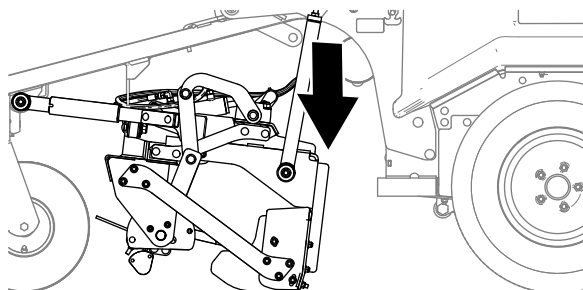

Figure 55

g365616

7. Shut off the engine, remove the key, and wait for all moving parts to stop.

Raising and Lowering the Optional Rear Attachment

1. Move the machine to the job site, and engage the parking brake.
2. Use the rear attachment-lift control (Figure 56) to adjust the position of an optional rear attachment as follows:
 - Move the rear attachment lift control forward to lower the rear attachment.
 - Move the rear attachment lift control rearward to raise the rear attachment.

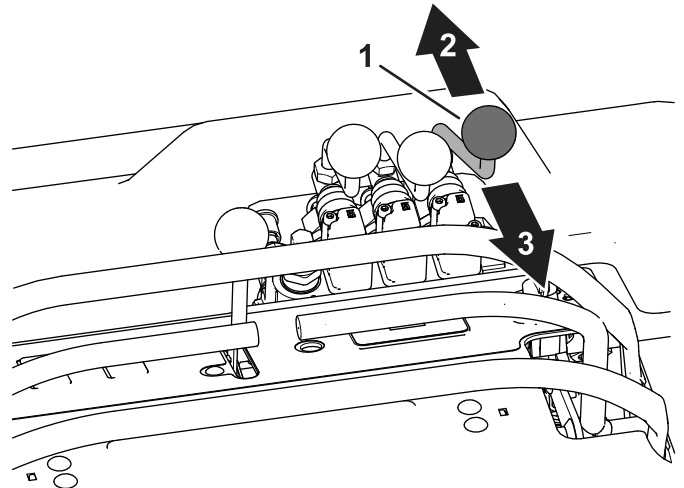

g384238

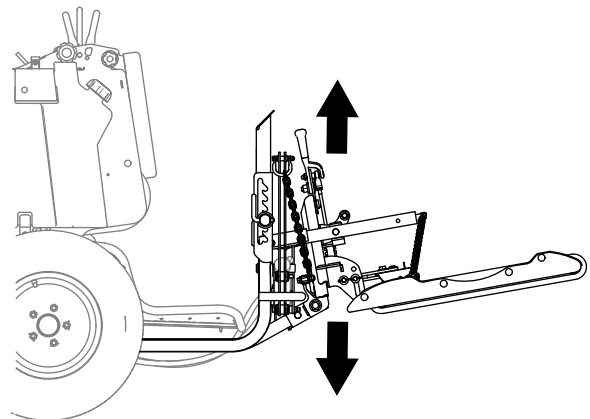

g335517

Figure 56

- | | |
|---------------------------------|-------------------------|
| 1. Rear attachment lift control | 3. Raise the attachment |
| 2. Lower the attachment | |

Operating Tips

Refer to the attachment *Operator's Manual* for specific operating instructions for any installed attachments.

Practice driving the machine; when operating the machine, consider the characteristics of ground speed and engine speed:

- To transfer maximum power to the wheels, move the throttle control to the FAST and slightly press the traction controls forward.
- Maintain constant engine speed by pressing the traction controls slowly; this allows the engine to keep up with the ground speed of the vehicle.
- Pushing the traction controls too quickly reduces the engine speed; which can reduce the torque-power that moves the vehicle.
- Alternatively, maximum ground speed is achieved when the throttle control is in the FAST position and the traction controls are slowly but fully pressed.

Note: If the attachment adapter becomes stuck to the traction unit adapter, insert a pry bar or a screwdriver into the pry slot to disengage the parts ([Figure 57](#)).

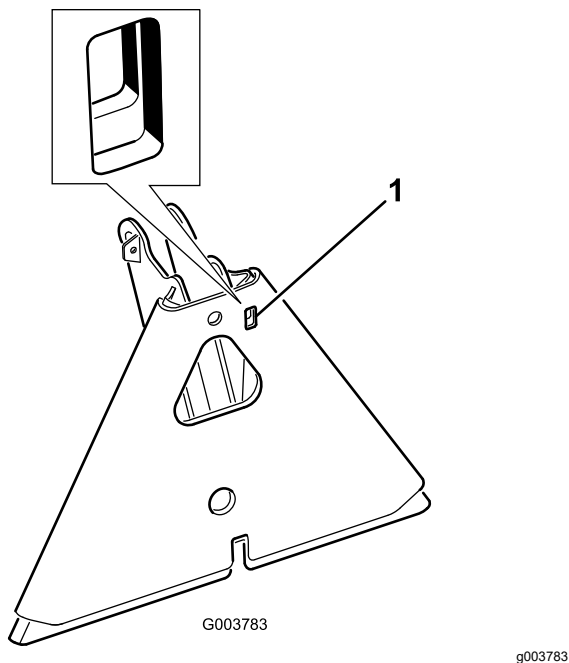

Figure 57

1. Pry slot

After Operation

After Operation Safety

- Park the machine on a level surface; engage the parking brake; shut off the engine; remove the key; and wait for all movement to stop before leaving the machine.
- Clean grass and debris from the muffler and engine compartment to help prevent fires. Clean up oil or fuel spills.
- Allow the engine to cool before storing the machine in any enclosure.
- Shut off the fuel before storing or transporting the machine.
- Never store the machine or fuel container where there is an open flame, spark, or pilot light, such as on a water heater or on other appliances.
- Keep all parts of the machine in good working condition and all hardware tightened.
- Replace all worn or damaged decals.

Moving a Non-Functioning Machine

If you must tow or push the machine, open the bypass valves to bypass the hydraulic fluid.

Important: Do not move the machine without first opening the bypass valves on the hydraulic pumps, otherwise you could damage motor components.

Do not move the machine faster than 4.8 km/h (3 mph); only move machines a very short distance. If you must move the machine more than a short distance, transport it on a trailer. If you exceed towing limits, severe damage to the hydraulic pumps may result.

⚠ CAUTION

The wheels can move freely when the bypass valves are opened. The machine can roll uncontrolled, possibly causing injury.

If you must tow the machine, move slowly and ensure that the machine does not collide with the towing vehicle.

1. Raise the mid-mount attachment and optional rear attachment.
2. Shut off the engine, remove the key, engage the parking brake, and chock the wheels.

3. Wait for all moving parts to stop and allow machine components to cool.
4. If attached, remove the optional rear attachment.
5. Access the bypass valves from under the rear of the machine.
6. With a 5/8 wrench, open the bypass valve on the bottom of the hydraulic pump by turning the valve approximately 2 full rotations as shown in .
7. Repeat step 6 to open the bypass valve on the bottom of the other hydraulic pump.

Note: The wheels can now spin freely.

Important: Do not rotate bypass valves more than 2 turns; this prevents the valves from falling out of the pump and ensures that hydraulic fluid does not spill.

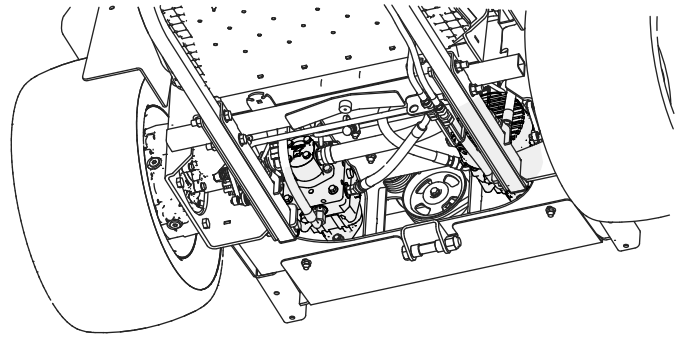

g386311

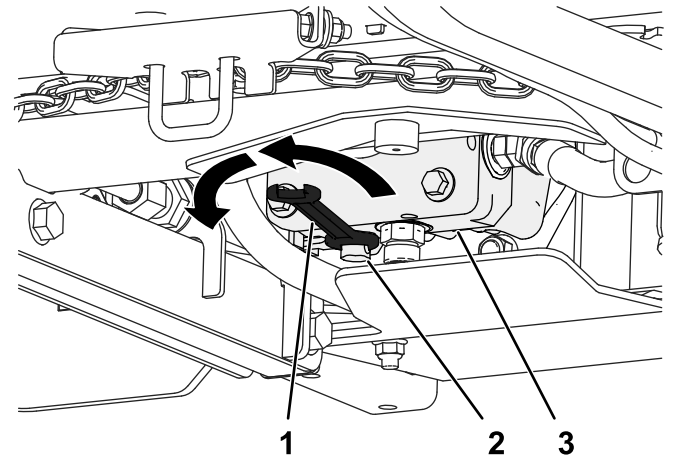

g386310

Figure 58

Underside shown, some parts hidden for clarity

1. Turn the wrench counterclockwise (as seen from below)
 2. Bypass valve
 3. Hydraulic pump
-
8. Remove the chocks from the wheels, disengage the parking brake, and move the machine to the desired location.

9. After moving the machine and before starting the engine, close and tighten the bypass valves for operation:

Important: Do not start or run the engine when the bypass valves are set to the open position.

- A. Shut off the engine, remove the key, engage the parking brake, and chock the wheels.
- B. Wait for all moving parts to stop and allow machine components to cool.
- C. Close, but do not tighten, the bypass valve by turning it approximately 2 full rotations until it stops.
- D. Torque the bypass valve to 12.4 to 14.7 N·m (110 to 130 in-lb).
- E. Repeat step D to close the bypass valve on the bottom of the other hydraulic pump.

Transporting the Machine

Use a heavy-duty trailer or truck to transport the machine. Use a full-width ramp. Ensure that the trailer or truck has all the necessary brakes, lighting, and marking as required by law. Please carefully read all the safety instructions. Knowing this information could help you or bystanders avoid injury. Refer to your local ordinances for trailer and tie-down requirements.

⚠ WARNING

Driving on the street or roadway without turn signals, lights, reflective markings, or a slow-moving-vehicle emblem is dangerous and can lead to accidents, causing personal injury.

Do not drive the machine on a public street or roadway.

Selecting a Trailer

⚠ WARNING

Loading a machine onto a trailer or truck increases the possibility of tip-over and could cause serious injury or death (Figure 59).

- Use only a full-width ramp; do not use individual ramps for each side of the machine.
- Ensure that the length of ramp is at least 4 times as long as the height of the trailer or truck bed to the ground.

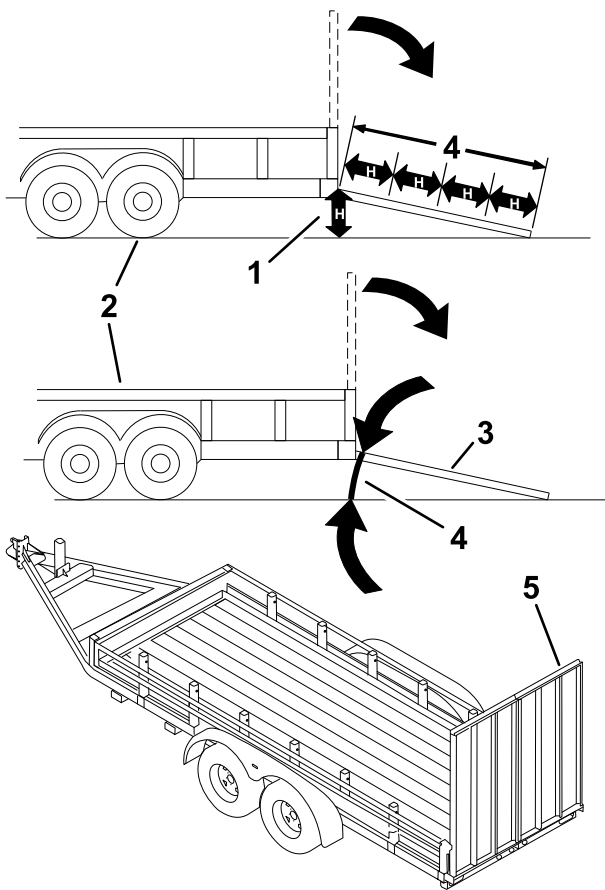

Figure 59

g337406

- | | |
|---------------------------------------------------------------------------------------------|-------------------------------------------------------|
| 1. Full-width ramp in stowed position | 3. H=height of the trailer or truck bed to the ground |
| 2. Ramp is at least 4 times as long as the height of the trailer or truck bed to the ground | 4. Trailer |

Loading the Machine

⚠ WARNING

Loading a machine onto a trailer or truck increases the possibility of tip-over and could cause serious injury or death.

- Use extreme caution when operating a machine on a ramp.
- Back the machine up the ramp and walk it forward down the ramp.
- Avoid sudden acceleration or deceleration while driving the machine on a ramp as this could cause a loss of control or a tip-over situation.

1. If using a trailer, connect it to the towing vehicle and connect the safety chains.
2. If applicable, connect the trailer brakes and lights.

3. Lower the ramp (Figure 59).
4. If installed, fully raise the mid-mount attachment and optional rear attachment.
5. Back the machine up the ramp (Figure 60).

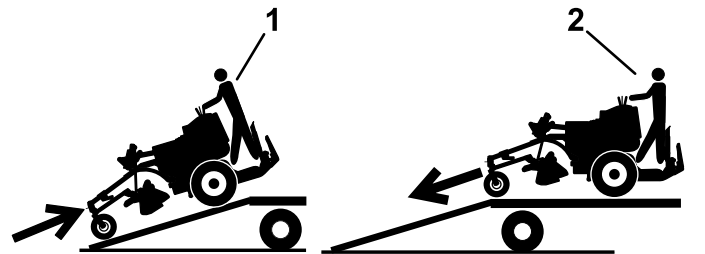

g337358

Figure 60

1. Back the machine up the ramp.
2. Drive the machine down the ramp.

6. Fully lower the mid-mount attachment and optional rear attachment.
7. Shut off the engine, remove the key, and engage the parking brake.
8. Tie down the machine at the front frame and the rear-attachment frame (Figure 61) with straps, chains, cable, or ropes.

Note: Refer to local regulations for tie-down requirements.

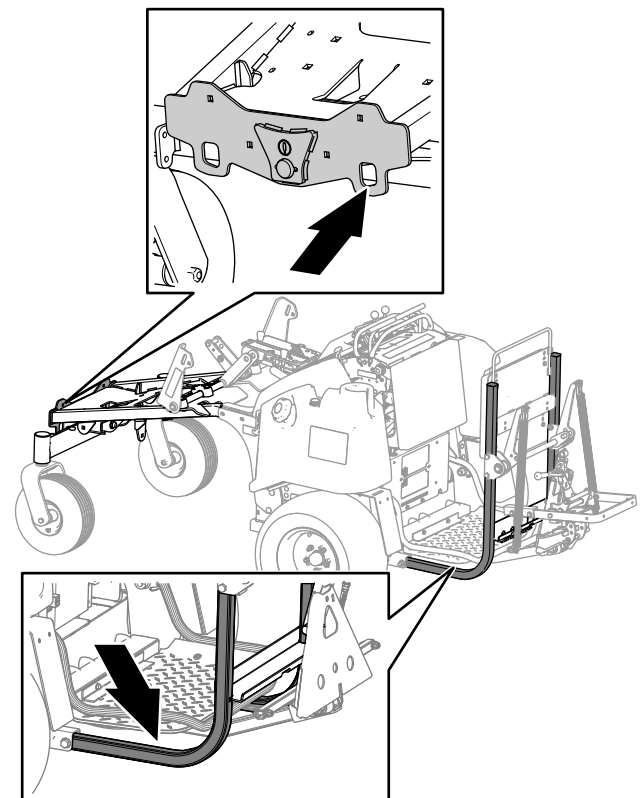

Figure 61

g386309

Maintenance

Note: Download a free copy of the electrical or hydraulic schematic by visiting www.Toro.com and searching for your machine from the Manuals link on the home page.

Maintenance Safety

- Before adjusting, cleaning, repairing, or leaving the machine, do the following:
 - Park the machine on a level surface.
 - Move the throttle switch to the low-idle position.
 - Lower the attachment.
 - Ensure that the traction is in neutral.
 - Engage the parking brake.
 - Shut off the engine and remove the key.
 - Wait for all moving parts to stop.
 - Allow machine components to cool before performing maintenance.
- If possible, do not perform maintenance while the engine is running. Keep away from moving parts.
- Use jack stands to support the machine or components when required.
- Carefully release pressure from components with stored energy.

Recommended Maintenance Schedule(s)

Maintenance Service Interval	Maintenance Procedure
After the first 50 hours	<ul style="list-style-type: none">• Change the engine oil and filter.
Before each use or daily	<ul style="list-style-type: none">• Check the safety-interlock system.• Check the engine-oil level.• Check the condition of the hydraulic lines and hoses.• Check the hydraulic-fluid level.
After each use	<ul style="list-style-type: none">• Clean the machine.
Every 50 hours	<ul style="list-style-type: none">• Grease the bearings and bushings. Grease the bearings and bushings after every washing.• Check the tire pressure.
Every 100 hours	<ul style="list-style-type: none">• Change the engine oil and filter.
Every 200 hours	<ul style="list-style-type: none">• Check the spark plug(s).• Change the fuel filter.
Every 250 hours	<ul style="list-style-type: none">• Replace the air filter.
Every 300 hours	<ul style="list-style-type: none">• Change the hydraulic filter.• Change the hydraulic fluid.
Every 500 hours	<ul style="list-style-type: none">• Replace the spark plug.
Every 1,000 hours	<ul style="list-style-type: none">• Replace the belt.
Monthly	<ul style="list-style-type: none">• Torque the wheel lug nuts.

Important: Refer to your engine owner's manual for additional maintenance procedures.

Daily Maintenance Checklist

Duplicate this page for routine use.

Maintenance Check Item	For the week of:						
	Mon.	Tues.	Wed.	Thurs.	Fri.	Sat.	Sun.
Check the safety interlock operation.							
Check the steering operation.							
Check the fuel level.							
Check the level of the engine oil.							
Check the condition of the air filter.							
Clean the cooling fins on the engine.							
Check unusual engine noises.							
Check unusual operating noises.							
Check the level of the hydraulic fluid.							
Check the hydraulic hoses for damage.							
Check for fluid leaks.							
Check the tire pressure.							
Check the instrument operation.							
Touch-up damaged paint.							

Notation for Areas of Concern		
Inspection performed by:		
Item	Date	Information

Pre-Maintenance Procedures

Important: Determine the left and right sides of the machine from the normal operating position.

⚠ CAUTION

If you leave the key in the ignition switch, someone could accidentally start the engine and seriously injure you or other bystanders.

Remove the key from the ignition before you do any maintenance.

Preparing for Maintenance

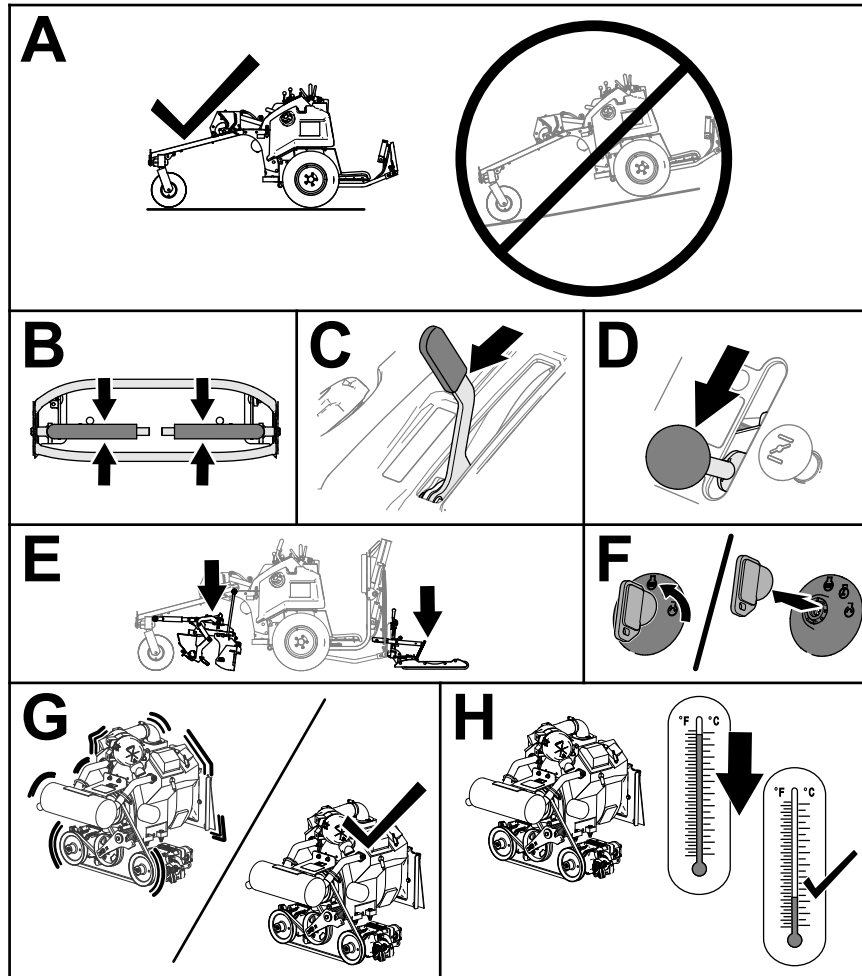

Figure 62

g366682

1. Park the machine on a level surface.
2. Ensure that the traction is in neutral.
3. Engage the parking brake.
4. Move the throttle to the SLOW position.
5. If installed, lower the mid-mount attachment and optional rear attachment.
6. Shut off the engine and remove the key.
7. Wait for all moving parts to stop.
8. Allow engine to cool.

Removing the Hood

1. Pull the latches up and off the 4 latch pins (Figure 63).

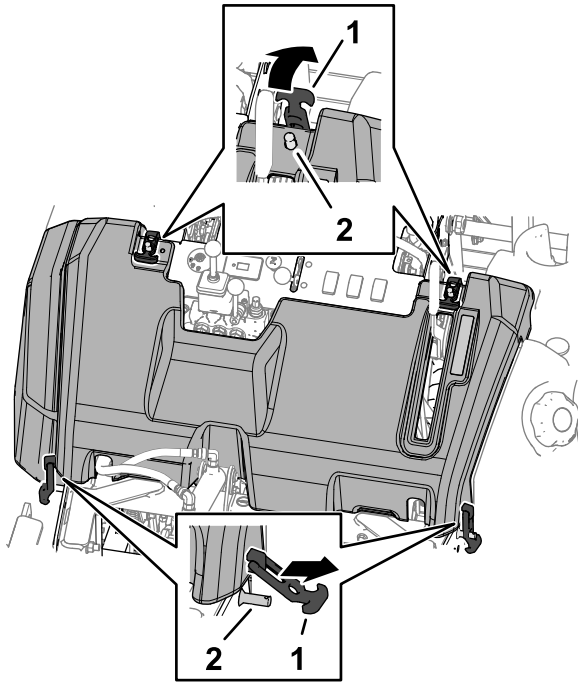

Figure 63

1. Latch
2. Latch pin

2. Lift the hood from the machine (Figure 64).

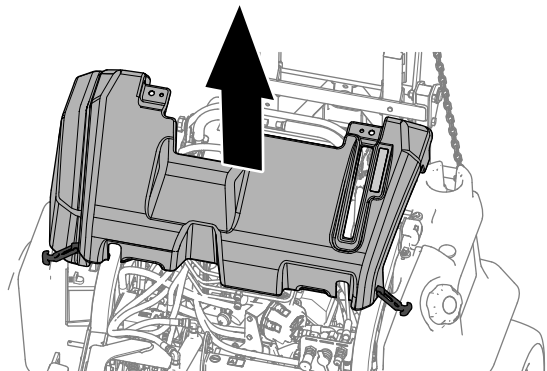

Figure 64

Installing the Hood

1. Lower the hood onto the machine (Figure 65).

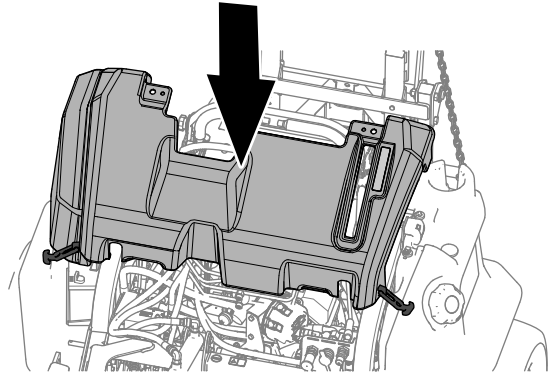

Figure 65

2. Pull the latches over the 4 latch pins to secure the hood (Figure 66).

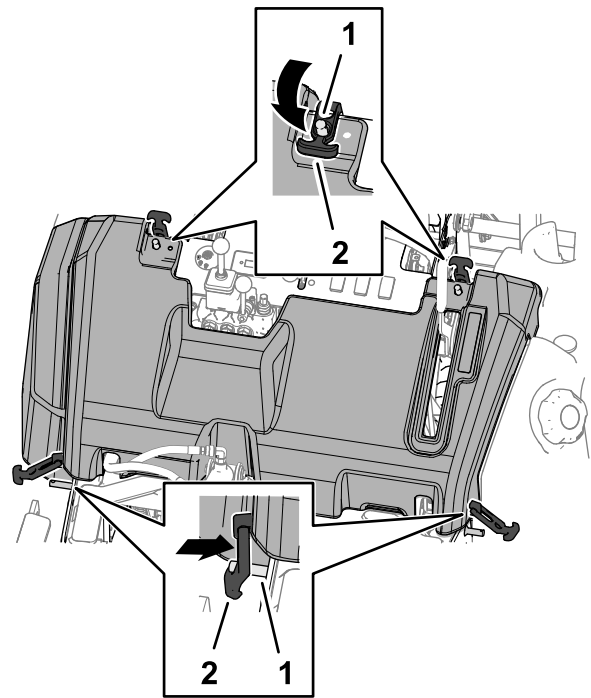

Figure 66

1. Latch pin
2. Latch

Lowering the Operator's Cushion

1. Loosen the 2 knobs that secure the operator's cushion to the control tower (Figure 67).

Important: The knobs are designed to remain on the machine; loosen each knob a only few turns, this prevents you from accidentally stripping them free of the retainers.

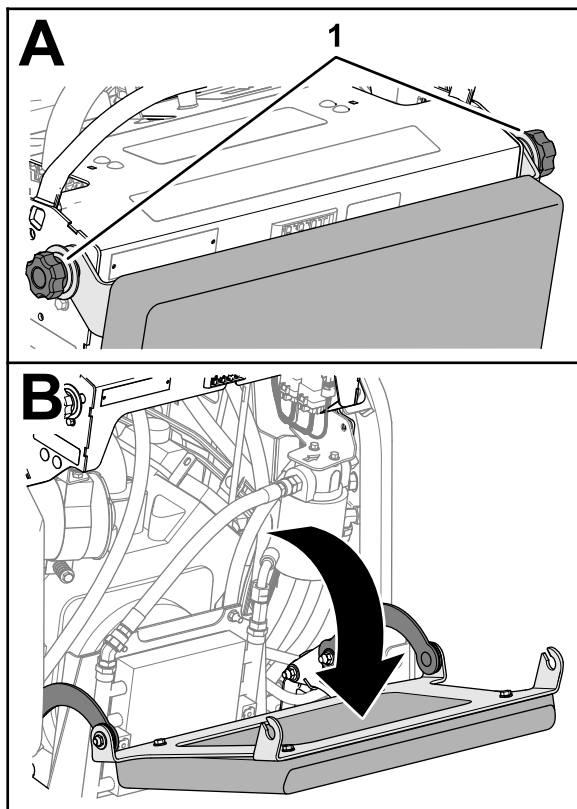

Figure 67

g333931

1. Knobs
2. Operator's cushion

2. Lower the operator's cushion (Figure 67).

Raising the Operator's Cushion

1. Rotate up the operator's cushion (Figure 68).

Note: Ensure that the slots in the frame of the cushion are fully seated to the flange bushings inboard of the knobs.

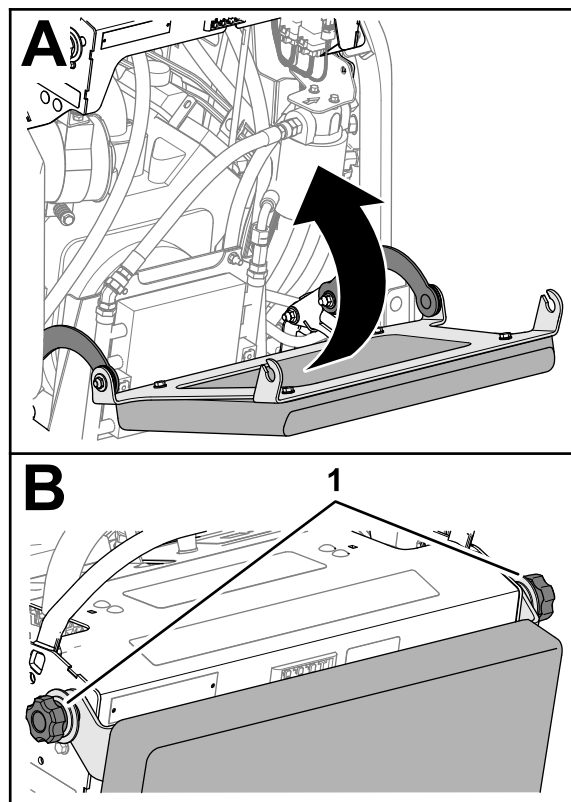

Figure 68

g333932

1. Operator's cushion
2. Knobs

2. Tighten the 2 knobs (Figure 68).

Lifting the Machine

⚠ WARNING

Mechanical or hydraulic jacks may fail to support the machine and cause serious injury.

Use jack stands when supporting the machine.

1. Raise the mid-mount attachment and optional rear attachment.
2. Park the machine on a level surface; engage the parking brake; shut off the engine; remove the key; and wait for all movement to stop before leaving the machine.
3. If attached, remove the optional rear attachment
4. Raise the machine using the designated jacking points as follows:
 - Front—center of the front caster wheel axle as shown in [Figure 69](#).

⚠ WARNING

The front axle can pivot; ensure that the floor jack is centered on the machine so that it does not shift while lifting; always use 2 jack stands to support the machine once it is lifted.

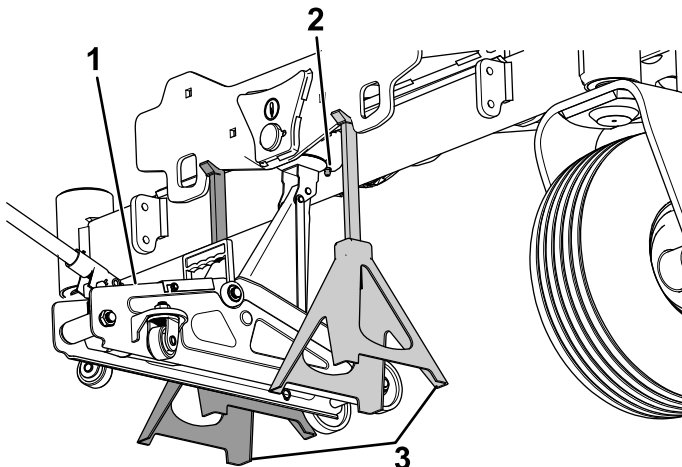

Figure 69

g396208

1. Floor jack centered on the axle.
2. Front jack point; do not allow the jack to contact the grease fitting.
3. Jack stands placed on both sides of the front axle plate.

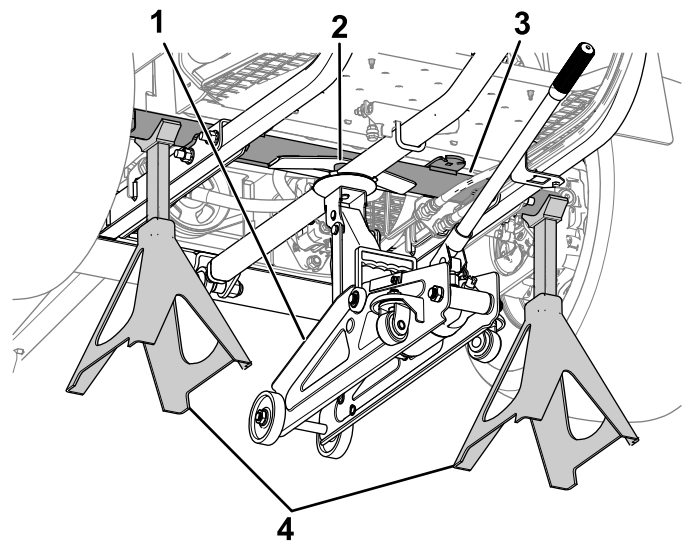

Figure 70

g396207

1. Floor jack
2. Rear jack point; floor jack under the rear tube of the frame assembly.
3. Rear tube of the frame assembly.
4. Jack stands placed under the far ends of the rear tube of the frame.

- Left and right sides—under the rear tube of the frame assembly behind the wheel motors ([Figure 70](#)).

Lubrication

Greasing the Bearings and Bushings

Service Interval: Every 50 hours Grease the bearings and bushings after every washing.

Grease Specification: No. 2 lithium grease

1. Prepare the machine for maintenance; refer to [Preparing for Maintenance \(page 45\)](#).
2. Wipe the grease fittings clean
3. Pump grease into the fittings.
4. Wipe off excess grease.

Note: Improper wash-down procedures can negatively affect bearing life. Do not wash down the machine when it is still hot and avoid directing high-pressure or high-volume spray at the bearings or seals.

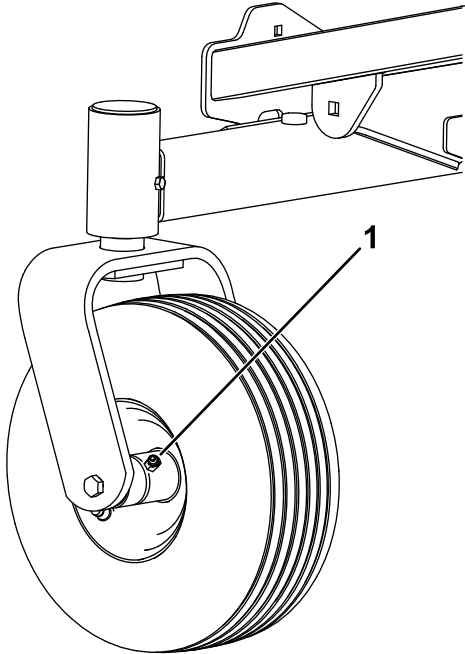

g396179

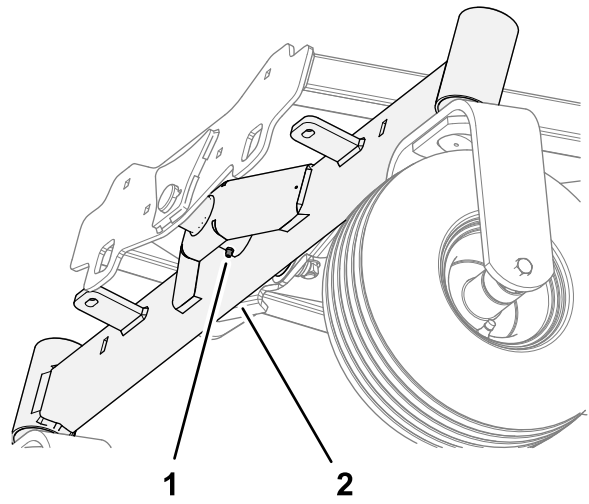

g366684

Figure 71
Front Axle

1. Grease fittings
2. Axle

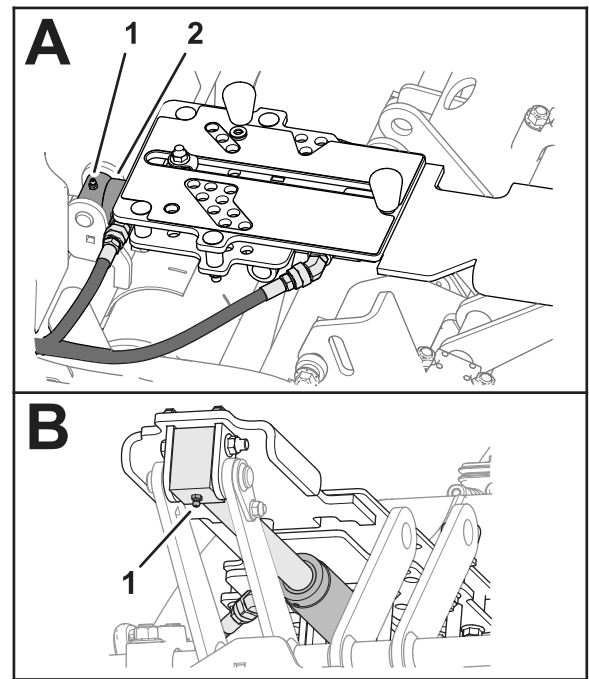

g384362

Figure 72
Mid-mount Attachment Lift Cylinder

1. Grease fitting
2. Mid-mount attachment lift cylinder

Engine Maintenance

Engine Safety

- Shut off the engine before checking the oil or adding oil to the crankcase.
- Do not change the governor speed or overspeed the engine.

Engine Oil Specification

Use high-quality engine oil that meets the following specifications:

API classification level: SJ or higher

Oil Viscosity: SAE 30—above 4°C (40°F)

Checking the Engine-Oil Level

Service Interval: Before each use or daily

Note: The engine is shipped with oil in the crankcase; however, you must check the oil level before and after you first start the engine.

1. Prepare the machine for maintenance; refer to [Preparing for Maintenance \(page 45\)](#).
2. Remove the hood; refer to [Removing the Hood \(page 46\)](#).
3. Clean around the dipstick and dipstick tube.
4. Remove the dipstick ([Figure 75](#)) and wipe it with a clean rag.

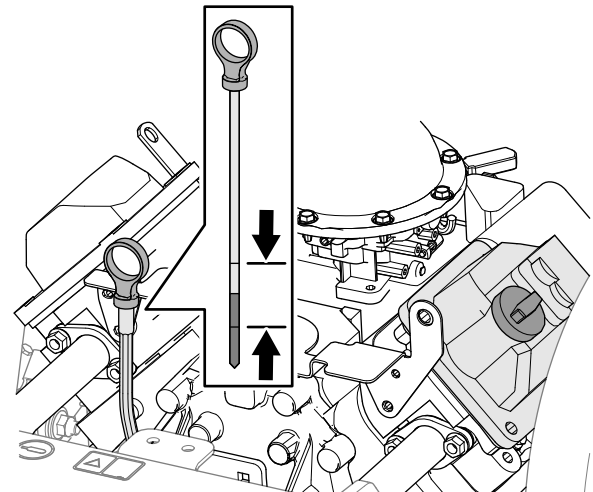

Figure 75

1. Dipstick (engine oil)

5. Insert the dipstick into the tube ([Figure 75](#)) until it is fully seated.

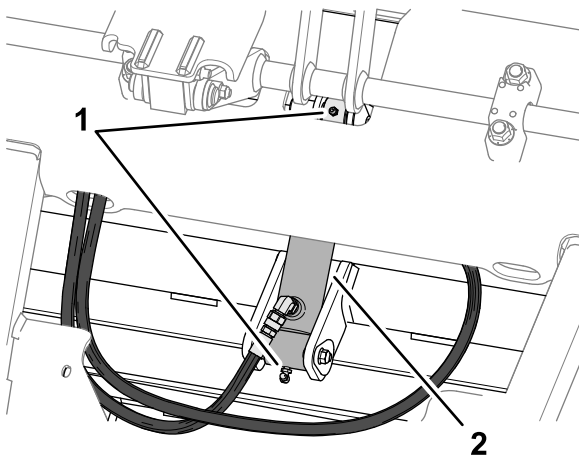

Figure 73

Mid-mount Attachment Tilt Cylinder

g366693

1. Grease fitting
2. Mid-mount attachment tilt cylinder

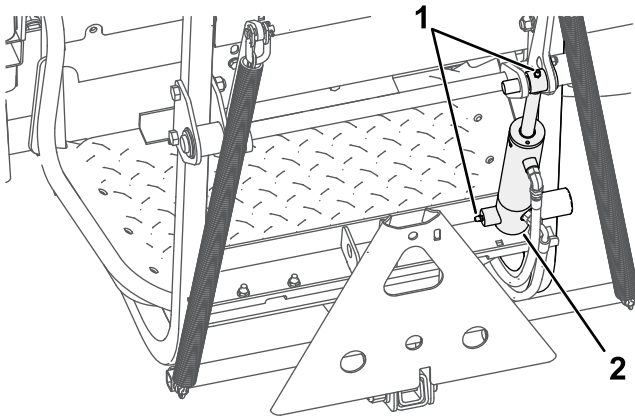

Figure 74

Rear Attachment Lift Cylinder

g385703

1. Grease fitting
2. Rear attachment lift cylinder

6. Remove the dipstick from the tube and check the oil level.

Important: Ensure that the oil level between the upper and lower mark on the dipstick. If you overfill or underfill the engine oil, you may damage engine when running it.

7. If the oil level is at the LOW mark on the dipstick, add oil as follows:
 - A. Clean the filler cap and valve cover (Figure 71).

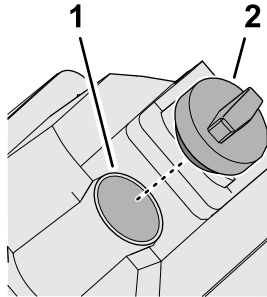

Figure 76

g374603

1. Valve cover
2. Filler cap

- B. Remove the filler cap.
 - C. Slowly add additional oil to bring the oil level to the F (full) mark on the dipstick.
 - D. Install the filler cap.
8. Fully insert the dipstick into the dipstick tube.

Important: You must fully seat the dipstick in the tube to seal the engine crankcase. Failure to seal the crankcase may result in engine damage.

9. Install the hood; refer to [Installing the Hood \(page 46\)](#).

Changing the Engine Oil and Filter

Service Interval: After the first 50 hours

Every 100 hours

Draining the Engine Oil

Required tools: Drain hose 13 mm (1/2 inch)

1. Start the engine and let it run for 5 minutes.

Note: This warms oil drains better.

2. Prepare the machine for maintenance; refer to [Preparing for Maintenance \(page 45\)](#).
3. Remove the hood; refer to [Removing the Hood \(page 46\)](#).
4. Remove the cap from the oil-drain valve, assemble a hose 13 mm (1/2 inch) onto the barbed fitting of the valve, and place the other end of the hose into a drain pan (Figure 77).

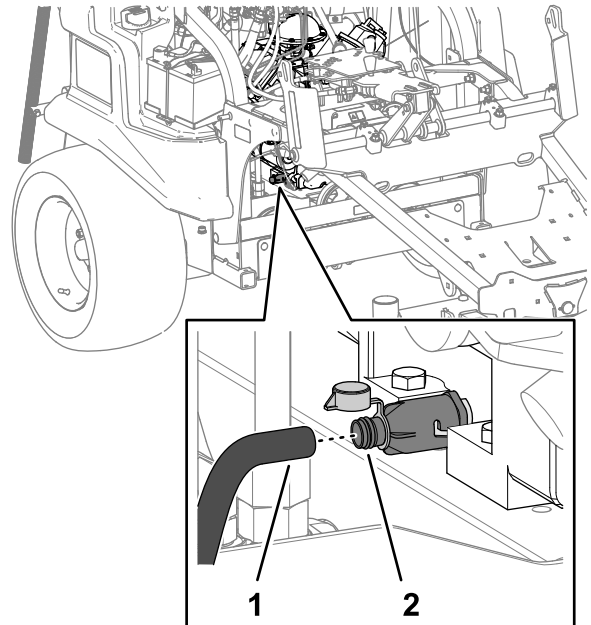

Figure 77

g366262

1. Hose
2. Oil-drain valve

5. Open the drain valve by rotate it counterclockwise slightly and pulling it outward (Figure 77).
6. When the oil has drained, push in drain valve, rotate it clockwise until it latches, and remove the hose.

Replacing the Oil Filter

1. Rotate the oil filter counterclockwise to remove it (Figure 78).

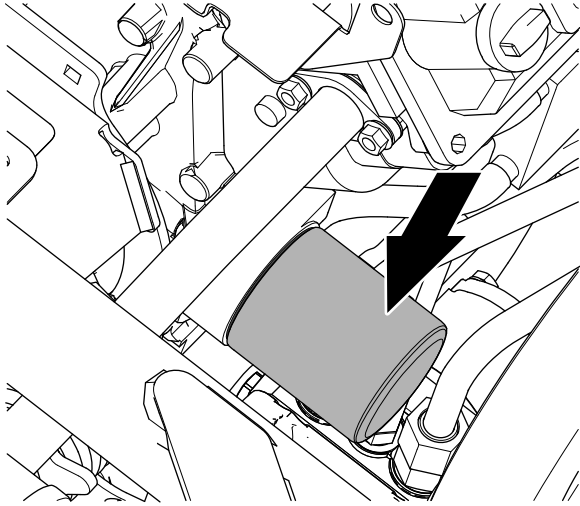

g366261

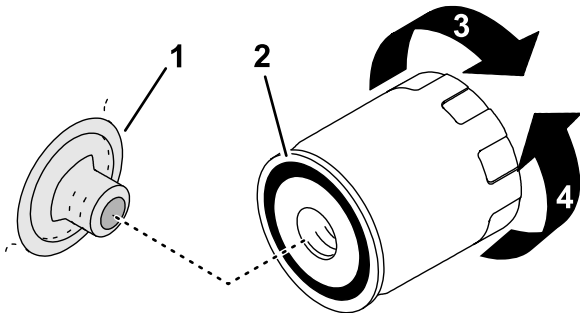

Figure 78

g366270

1. Filter adapter
 2. Gasket (oil filter)
 3. Loosen
 4. Tighten
-
2. Wipe the filter adapter with a clean rag.
 3. Fill the new oil filter with the specified oil; refer to [Engine Oil Specification \(page 50\)](#).
 4. Allow 1 to 2 minutes for the oil to be absorbed by filter element, then pour off the excess oil.
 5. Apply a thin coat of oil to the gasket of the filter (Figure 78).
 6. Thread the oil filter onto the filter adapter until the rubber gasket contacts the filter adapter, then tighten the filter an additional 1/2 turn (Figure 78).

Adding Oil to the Engine

Oil Quantity: with the filter 2.0 L (2.1 US qt)

1. Remove the fill cap from the valve cover (Figure 73) and slowly pour approximately 80% of the specified amount of oil: 2.0 L (2.1 US qt) into the filler neck of the valve cover.

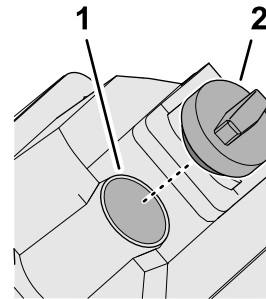

Figure 79

g374603

1. Valve cover
2. Filler cap

2. Check the oil level.
3. Slowly add additional oil to bring the oil level to the F (full) mark on the dipstick (Figure 67).

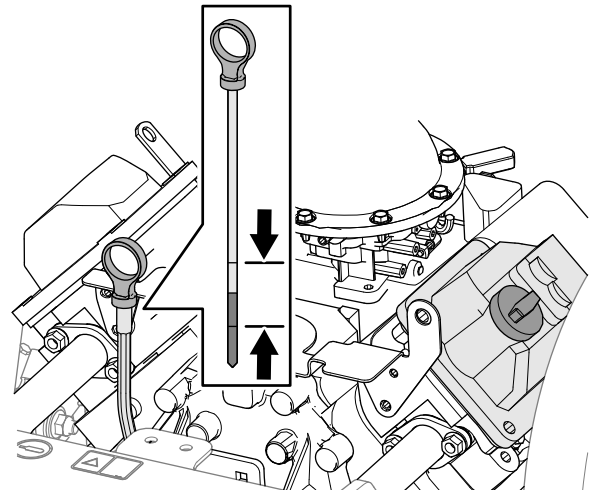

Figure 80

g333929

1. Dipstick (engine oil)
-
4. Install the fill cap.
 5. Fully insert the dipstick into the dipstick tube.
Important: You must fully seat the dipstick in the tube to seal the engine crankcase. Failure to seal the crankcase may result in engine damage.
 6. Install the hood; refer to [Installing the Hood \(page 46\)](#)

Servicing the Air Cleaner

Removing the Air Filter

Service Interval: Every 250 hours

1. Prepare the machine for maintenance; refer to [Preparing for Maintenance \(page 45\)](#).
2. Lower the operator's pad; refer to [Lowering the Operator's Cushion \(page 47\)](#).
3. Release the latches securing the air-cleaner cover to the air-cleaner body ([Figure 65](#)).

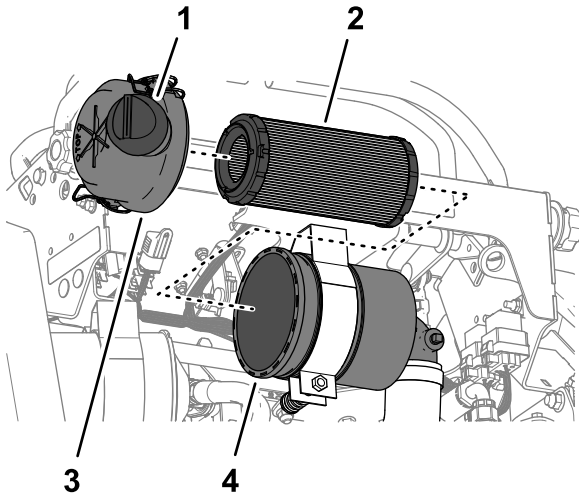

Figure 81

g366104

- | | |
|-----------------------|----------------------|
| 1. Dirt-ejection port | 3. Air-cleaner cover |
| 2. Filter element | 4. Air-cleaner body |

4. Remove the cover from the air-cleaner body.
5. Remove the dirt-ejection port from the cover, clean the cavity of the port and the cover, and assemble the ejection port onto the cover ([Figure 65](#)).
6. Before removing the filter element, use low-pressure air (40 psi, clean and dry) to help remove large accumulations of debris packed between the outside of the element and the air-cleaner body.

Important: Avoid using high-pressure air, which could force dirt through the filter into the intake tract. This cleaning process prevents debris from migrating into the intake when the primary filter is removed.

7. Remove the filter element.

Note: Do not clean a used element because you may damage the filter media.

Installing the Air Filter

1. Inspect the new filter for shipping damage, checking the sealing end of the filter and the body.

Important: Do not use a damaged element.

2. Insert the new filter by applying pressure to the outer rim of the element to seat it in the canister.

Note: Do not apply pressure to the flexible center of the filter.

3. Assemble the air-cleaner cover to the air-cleaner body, and secure the cover with the latches.
4. Raise the operator's pad; refer to [Raising the Operator's Cushion \(page 47\)](#).

Servicing the Spark Plug(s)

Service Interval: Every 200 hours—Check the spark plug(s).

Every 500 hours—Replace the spark plug.

Removing the Spark Plug

1. Prepare the machine for maintenance; refer to [Preparing for Maintenance \(page 45\)](#).
2. Remove the hood; refer to [Removing the Hood \(page 46\)](#).
3. Clean the area around the base of the plug(s) to keep dirt and debris out of the engine.
4. Remove the 2 spark-plug wires as shown in [Figure 82](#).

Note: Use a spark-plug socket when removing the spark plugs.

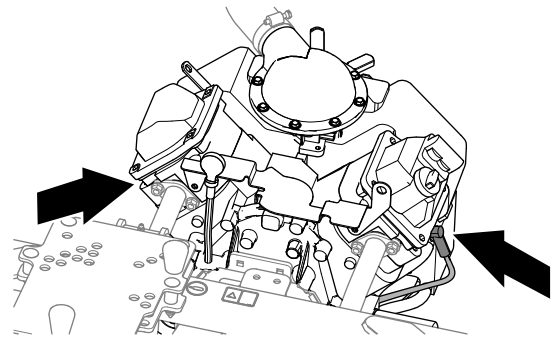

Figure 82

g366264

5. Remove the spark plugs.

Checking the Spark Plug

1. Check the spark plug—if you see light brown or gray on the insulator, the engine is operating properly.

Note: A black coating on the insulator may mean the air cleaner is dirty.

Important: Do not clean the spark plug(s). Always replace the spark plug(s) when it has a black coating, worn electrodes, an oily film, or cracks.

2. Adjust the air gap (Figure 83) between the center electrode and side electrode to 0.76 mm (0.030 inch).

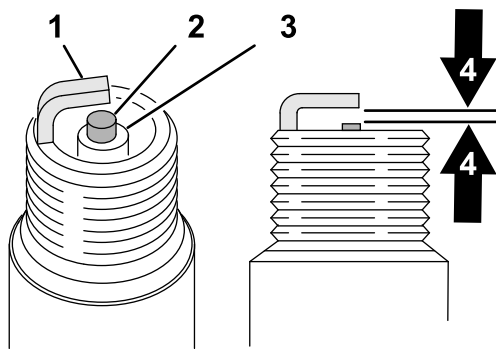

Figure 83

g326888

1. Center electrode
2. Side electrode
3. Insulator
4. Air gap—0.76 mm (0.030 inch)

Installing the Spark Plug

1. Install and torque the 2 spark plugs (Figure 78).
Note: Use a spark-plug socket and torque wrench to tighten the spark plugs.
2. Install the spark-plug wires onto the spark plugs.
3. Install the hood; refer to [Installing the Hood](#) (page 46)

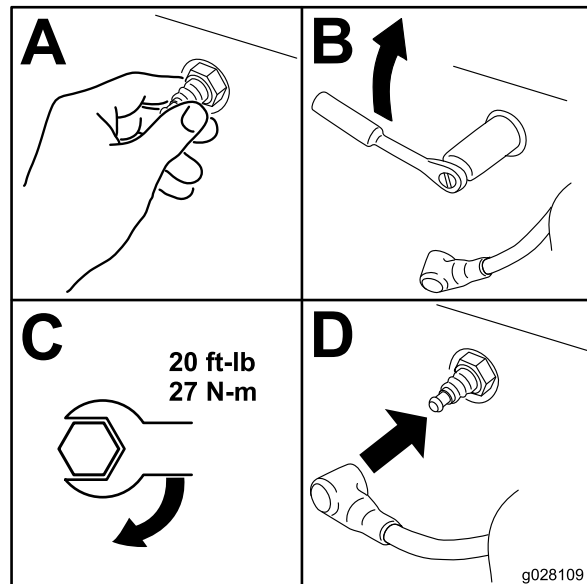

Figure 84

g028109

g028109

3. Repeat steps 1 and 2 for the other spark plug.

Fuel System Maintenance

⚠ DANGER

Under certain conditions, fuel is extremely flammable and highly explosive. A fire or explosion from fuel can burn you and others and can damage property.

- Drain fuel from the fuel tanks when the engine is cold. Do this outdoors in an open area. Wipe up any fuel that spills.
- Never smoke when draining fuel, and stay away from an open flame or where a spark may ignite the fumes.

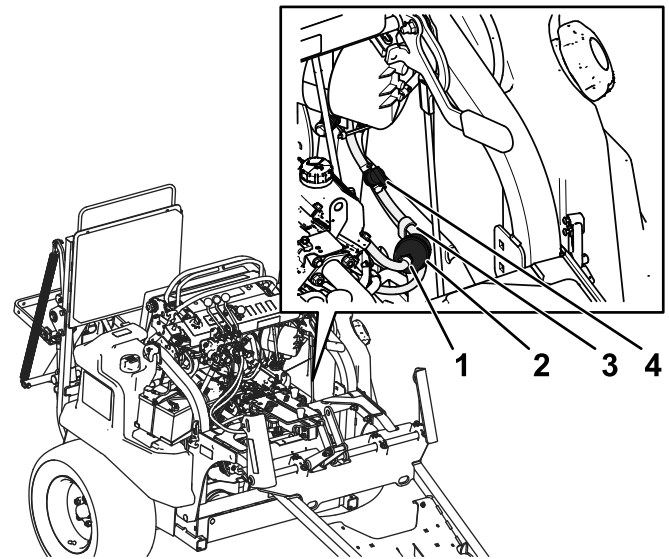

Figure 85

Changing the Fuel Filter

Service Interval: Every 200 hours

1. Park the machine on a level surface, engage the parking brake, and move the throttle to the SLOW position.
2. If installed, lower the mid-mount attachment and optional rear attachment.
3. Shut off the engine and remove the key.
4. Wait for all moving parts to stop and allow machine components to cool.
5. Loosen the fuel tank cap to relieve pressure.
Note: To avoid spilling fuel, you may drain the tank before replacing the filter; refer to [Draining the Fuel Tank \(page 55\)](#).
6. Remove the hood; refer to [Removing the Hood \(page 46\)](#).
7. Clamp the fuel lines on both sides of the fuel filter ([Figure 85](#)).

1. Hose clamp
2. Filter
3. Fuel hoses
4. Fuel shutoff

8. Squeeze the ends of the hose clamps together and slide them away from the filter ([Figure 85](#)).
9. Place a drain pan under the fuel lines to catch any leaks, then remove the filter from the fuel lines.
10. Slide the fuel lines on the new fuel filter fittings, ensuring that the arrow on the filter points away from the fuel line coming from the fuel tank and toward the line going to the fuel pump.

Important: Never install a dirty filter.

11. Move the hose clamps close to the filter.
12. Remove the clamp blocking fuel flow and open the fuel valves.
13. Secure the fuel tank cap and install the hood; refer to [Installing the Hood \(page 46\)](#).

Draining the Fuel Tank

1. Park the machine on a level surface, engage the parking brake, and move the throttle to the SLOW position.
2. If installed, lower the mid-mount attachment and optional rear attachment.
3. Shut off the engine and remove the key.
4. Wait for all moving parts to stop and allow machine components to cool.
5. Syphon the fuel from the tank using a pump-type syphon.

Electrical System Maintenance

Replacing the Fuses

1. Prepare the machine for maintenance; refer to [Preparing for Maintenance \(page 45\)](#).
2. Lower the operator's cushion; refer to [Lowering the Operator's Cushion \(page 47\)](#).
3. Remove the open fuse from the fuse block ([Figure 80](#)).

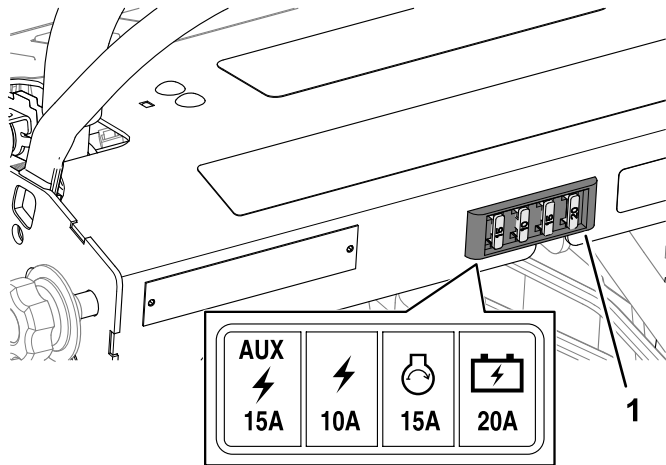

Figure 86

g385715

1. Fuse block
-
4. Insert a new fuse of the same amperage into the fuse-block slot.
 5. Raise and secure the operator's cushion; refer to [Raising the Operator's Cushion \(page 47\)](#).

Drive System Maintenance

Checking the Tire Air Pressure

Service Interval: Every 50 hours/Monthly (whichever comes first)

Incorrect tire air pressure can cause an uneven performance of the mid-mount attachment.

Note: Check the tires when they are cold to get accurate air-pressure readings.

1. Measure the tire pressure before operating the machine.

Note: The specified air pressure for the front and rear tires are 124 kPa (15 psi).

2. If needed, adjust the air pressure in the tires to the specified air pressure.

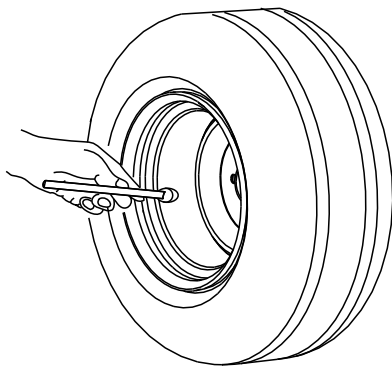

G001055

Figure 87

g001055

Torquing the Wheel Lug Nuts

Service Interval: Monthly

Wheel-lug nut torque specification: 129 N·m (95 ft-lb).

Torque the lug nuts at the rear wheels in the pattern as shown in [Figure 88](#) to the specified torque.

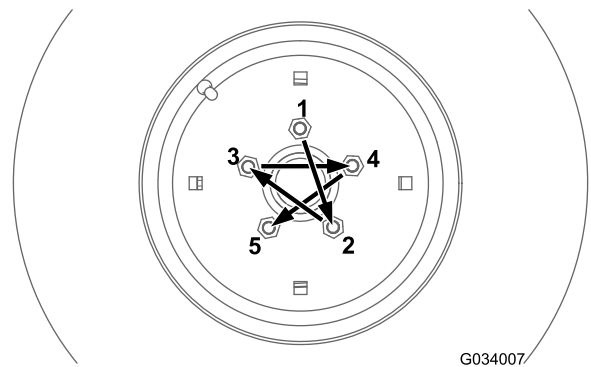

G034007

g034007

Figure 88

Torquing the Caster Wheel Nuts

Note: This is only necessary after removing or replacing the front caster wheels.

Tighten the locknut until the wheel no longer spins freely, then slowly loosen the locknut just enough so the wheel can spin freely; repeat this for the other caster wheel.

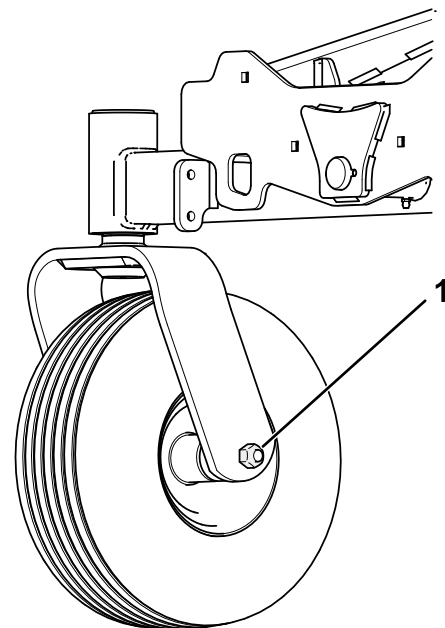

Figure 89

g387361

1. Caster wheel locknut

Belt Maintenance

Replacing the Belt

Service Interval: Every 1,000 hours

1. Prepare the machine for maintenance; refer to [Preparing for Maintenance \(page 45\)](#).
2. At the bottom, front of the engine, insert a socket wrench or breaker bar into the idler tension arm, and move the bracket up to relieve belt tension ([Figure 90](#)).

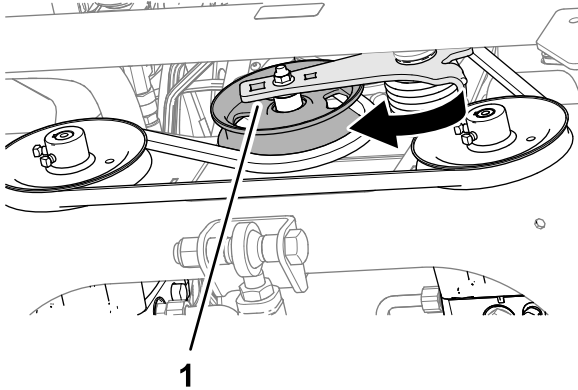

Figure 90

g363632

1. Idler tension arm

3. Slip the belt from the pulleys ([Figure 91](#)).

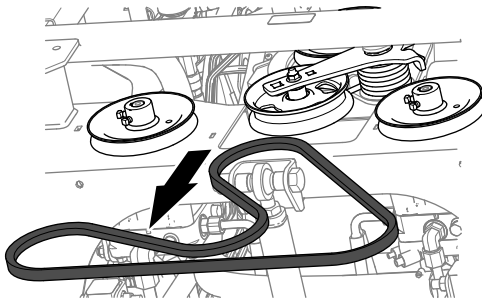

Figure 91

g363633

4. Route the new belt around the pulleys as shown in [Figure 92](#).

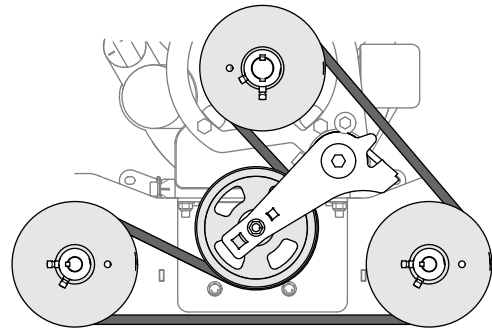

Figure 92

g363631

5. Remove the socket wrench or breaker bar from the idler tension arm.

Hydraulic System Maintenance

Hydraulic System Safety

- Seek immediate medical attention if fluid is injected into skin. Injected fluid must be surgically removed within a few hours by a doctor.
- Ensure that all hydraulic-fluid hoses and lines are in good condition and all hydraulic connections and fittings are tight before applying pressure to the hydraulic system.
- Keep your body and hands away from pinhole leaks or nozzles that eject high-pressure hydraulic fluid.
- Use cardboard or paper to find hydraulic leaks.
- Safely relieve all pressure in the hydraulic system before performing any work on the hydraulic system.

Checking the Hydraulic Lines and Hoses

Service Interval: Before each use or daily

Check the hydraulic lines and hoses daily for leaks, kinked lines, loose mounting supports, wear, loose fittings, weather deterioration, and chemical deterioration. Make all necessary repairs before operating.

Hydraulic-Fluid Specifications

Recommended fluid: Toro Premium Transmission/Hydraulic Tractor Fluid (available in 5-gallon pails or 55-gallon drums. See the *Parts Catalog* or contact an authorized Toro distributor for part numbers.)

Alternate fluids: If the Toro fluid is not available, Mobil® 424 hydraulic fluid may be used.

Note: Toro does not assume responsibility for damage caused by improper substitutions.

Note: Many hydraulic fluids are almost colorless, making it difficult to spot leaks. A red dye additive for the hydraulic-system fluid is available in 20 ml (2/3 fl oz) bottles. 1 bottle is sufficient for 15 to 22 L (4 to 6 gallons) of hydraulic fluid. Order Part Number 44-2500 from your authorized Toro distributor.

Checking the Hydraulic-Fluid Level

Service Interval: Before each use or daily

1. Fully raise all hydraulic attachment to the transport position.
2. Prepare the machine for maintenance; refer to [Preparing for Maintenance \(page 45\)](#).
3. Remove the hood; refer to [Removing the Hood \(page 46\)](#).
4. Clean the area around the hydraulic-tank dipstick and cap ([Figure 93](#)).

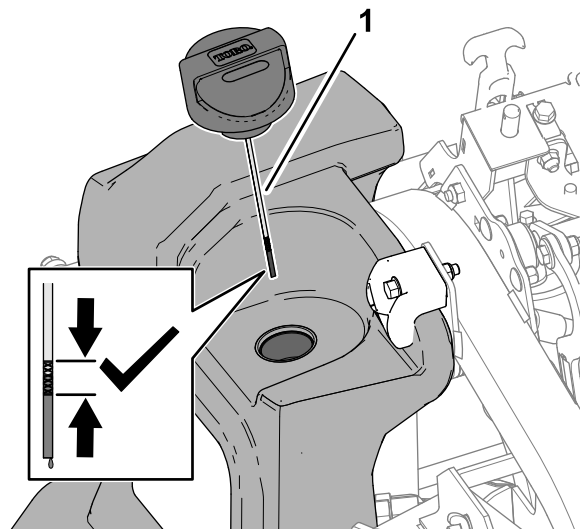

Figure 93

g366283

1. Dipstick and cap
5. Remove the dipstick and cap from the tank and wipe it with a clean rag.
6. Insert the dipstick into the tank ([Figure 93](#)).
7. Remove dipstick and cap ([Figure 93](#)) and check the level of the fluid.
Note: You should see the fluid level is between the LOW mark and the FULL mark on the dipstick.
8. If the fluid level is low, add the specified hydraulic fluid to the reservoir to raise the level to the FULL mark on the dipstick.
9. Install the dipstick and cap ([Figure 93](#)) into the tank.
10. Install the hood; refer to [Installing the Hood \(page 46\)](#).

Changing the Hydraulic Filter

Service Interval: Every 300 hours

Removing the Hydraulic Filter

1. Prepare the machine for maintenance; refer to [Preparing for Maintenance \(page 45\)](#).
2. Lower the operator's cushion; refer to [Lowering the Operator's Cushion \(page 47\)](#).
3. Align the drain pan under the hydraulic filter.
4. Remove the filter from the filter head ([Figure 94](#)).

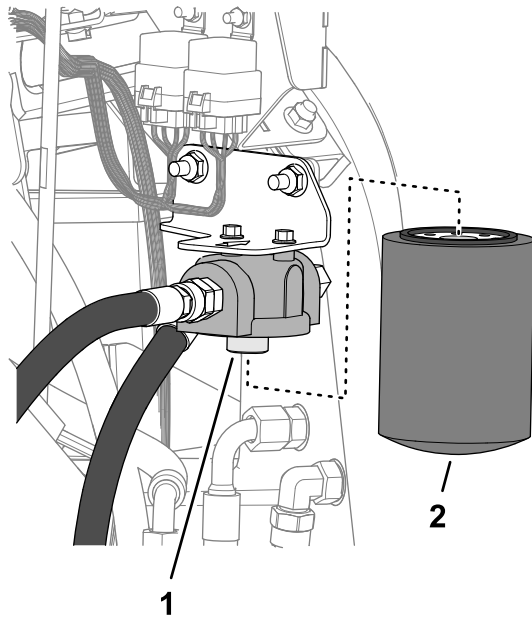

Figure 94

g366695

1. Filter head

2. Filter

Installing the Filter

1. Clean the filter mounting flange of the filter head.
2. Apply a thin coat of the specified hydraulic fluid to the gasket of the new filter; refer to [Hydraulic-Fluid Specifications \(page 59\)](#).
3. Fill the filter with the specified hydraulic fluid.
4. Thread the filter onto the filter head until the seal contacts the mounting flange, then tighten the filter an additional 1/2 turn.
5. Start the engine, check for leaks around the filter and filter head, shut off the engine, and remove the key.

Note: Repair all hydraulic leaks.

6. Raise and secure the operator's cushion; refer to [Raising the Operator's Cushion \(page 47\)](#).

Changing the Hydraulic Fluid

Service Interval: Every 300 hours

Draining the Tank

Hydraulic-tank capacity: 28.4 L (7.5 US gallons)

1. Prepare the machine for maintenance; refer to [Preparing for Maintenance \(page 45\)](#).
2. Remove the hood; refer to [Removing the Hood \(page 46\)](#).
3. Align a drain container with a 30 L (8 US gallons) or larger capacity under the forward corner of the hydraulic tank ([Figure 95](#)).

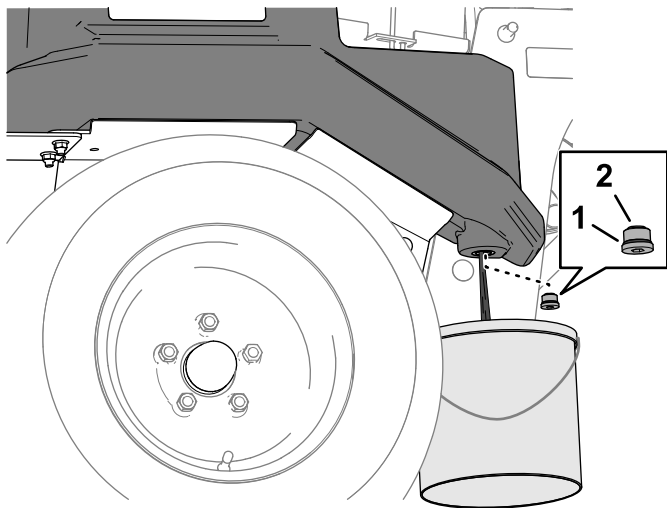

g374452

Figure 95

1. O-ring
2. Magnet (drain plug)

-
4. Remove the drain plug from the tank, and wait for the hydraulic fluid to drain.
 5. Check the drain plug for steel fragments.

Note: Contact your authorized Toro distributor if the end of the plug is covered with steel fragments.

6. Check the O-ring of the drain plug for damage or wear.

Important: Replace a damaged or worn O-ring.

Filling the Tank

1. Wipe clean the drain plug and install it into the tank.
2. Add 28.4 L (7.5 US gallons) of the specified hydraulic fluid into the hydraulic tank.
3. Check the drain plug for leaks.

Important: Repair all hydraulic leaks.

4. Install the hood; refer to [Installing the Hood \(page 46\)](#).

Cleaning

Cleaning the Machine

Service Interval: After each use

Important: Do not use brackish or reclaimed water to clean the machine.

Important: Do not pressure wash the machine

1. Park the machine on a level surface, fully raise and latch the handlebar to engage the parking brake, shut off the engine, remove the key, and wait for all moving parts to stop.
2. Thoroughly wash the machine.
 - Use a garden hose without a nozzle to avoid forcing water past the seals and contaminating bearing grease.
 - Use a brush to remove caked-on material.
 - Use mild detergent to clean the covers.
3. After cleaning, apply a coat of auto wax periodically to maintain the glossy finish of the cover.
4. Inspect the machine for damage, oil leaks, and component wear.

California Proposition 65 Warning Information

What is this warning?

You may see a product for sale that has a warning label like the following:



WARNING: Cancer and Reproductive Harm—www.p65Warnings.ca.gov.

What is Prop 65?

Prop 65 applies to any company operating in California, selling products in California, or manufacturing products that may be sold in or brought into California. It mandates that the Governor of California maintain and publish a list of chemicals known to cause cancer, birth defects, and/or other reproductive harm. The list, which is updated annually, includes hundreds of chemicals found in many everyday items. The purpose of Prop 65 is to inform the public about exposure to these chemicals.

Prop 65 does not ban the sale of products containing these chemicals but instead requires warnings on any product, product packaging, or literature with the product. Moreover, a Prop 65 warning does not mean that a product is in violation of any product safety standards or requirements. In fact, the California government has clarified that a Prop 65 warning "is not the same as a regulatory decision that a product is 'safe' or 'unsafe.'" Many of these chemicals have been used in everyday products for years without documented harm. For more information, go to <https://oag.ca.gov/prop65/faqs-view-all>.

A Prop 65 warning means that a company has either (1) evaluated the exposure and has concluded that it exceeds the "no significant risk level"; or (2) has chosen to provide a warning based on its understanding about the presence of a listed chemical without attempting to evaluate the exposure.

Does this law apply everywhere?

Prop 65 warnings are required under California law only. These warnings are seen throughout California in a wide range of settings, including but not limited to restaurants, grocery stores, hotels, schools, and hospitals, and on a wide variety of products. Additionally, some online and mail order retailers provide Prop 65 warnings on their websites or in catalogs.

How do the California warnings compare to federal limits?

Prop 65 standards are often more stringent than federal and international standards. There are various substances that require a Prop 65 warning at levels that are far lower than federal action limits. For example, the Prop 65 standard for warnings for lead is 0.5 µg/day, which is well below the federal and international standards.

Why don't all similar products carry the warning?

- Products sold in California require Prop 65 labelling while similar products sold elsewhere do not.
- A company involved in a Prop 65 lawsuit reaching a settlement may be required to use Prop 65 warnings for its products, but other companies making similar products may have no such requirement.
- The enforcement of Prop 65 is inconsistent.
- Companies may elect not to provide warnings because they conclude that they are not required to do so under Prop 65; a lack of warnings for a product does not mean that the product is free of listed chemicals at similar levels.

Why does Toro include this warning?

Toro has chosen to provide consumers with as much information as possible so that they can make informed decisions about the products they buy and use. Toro provides warnings in certain cases based on its knowledge of the presence of one or more listed chemicals without evaluating the level of exposure, as not all the listed chemicals provide exposure limit requirements. While the exposure from Toro products may be negligible or well within the "no significant risk" range, out of an abundance of caution, Toro has elected to provide the Prop 65 warnings. Moreover, if Toro does not provide these warnings, it could be sued by the State of California or by private parties seeking to enforce Prop 65 and subject to substantial penalties.



The Toro Warranty

Two-Year or 1,500 Hours Limited Warranty

Conditions and Products Covered

The Toro Company warrants your Toro Commercial product ("Product") to be free from defects in materials or workmanship for 2 years or 1,500 operational hours*, whichever occurs first. This warranty is applicable to all products with the exception of Aerators (refer to separate warranty statements for these products). Where a warrantable condition exists, we will repair the Product at no cost to you including diagnostics, labor, parts, and transportation. This warranty begins on the date the Product is delivered to the original retail purchaser.

* Product equipped with an hour meter.

Instructions for Obtaining Warranty Service

You are responsible for notifying the Commercial Products Distributor or Authorized Commercial Products Dealer from whom you purchased the Product as soon as you believe a warrantable condition exists. If you need help locating a Commercial Products Distributor or Authorized Dealer, or if you have questions regarding your warranty rights or responsibilities, you may contact us at:

Toro Commercial Products Service Department
8111 Lyndale Avenue South
Bloomington, MN 55420-1196

952-888-8801 or 800-952-2740
E-mail: commercial.warranty@toro.com

Owner Responsibilities

As the product owner, you are responsible for required maintenance and adjustments stated in your *Operator's Manual*. Repairs for product issues caused by failure to perform required maintenance and adjustments are not covered under this warranty.

Items and Conditions Not Covered

Not all product failures or malfunctions that occur during the warranty period are defects in materials or workmanship. This warranty does not cover the following:

- Product failures which result from the use of non-Toro replacement parts, or from installation and use of add-on, or modified non-Toro branded accessories and products.
- Product failures which result from failure to perform recommended maintenance and/or adjustments.
- Product failures which result from operating the Product in an abusive, negligent, or reckless manner.
- Parts consumed through use that are not defective. Examples of parts which are consumed, or used up, during normal Product operation include, but are not limited to, brake pads and linings, clutch linings, blades, reels, rollers and bearings (sealed or greasable), bed knives, spark plugs, castor wheels and bearings, tires, filters, belts, and certain sprayer components such as diaphragms, nozzles, flow meters, and check valves.
- Failures caused by outside influence, including, but not limited to, weather, storage practices, contamination, use of unapproved fuels, coolants, lubricants, additives, fertilizers, water, or chemicals.
- Failure or performance issues due to the use of fuels (e.g. gasoline, diesel, or biodiesel) that do not conform to their respective industry standards.
- Normal noise, vibration, wear and tear, and deterioration. Normal "wear and tear" includes, but is not limited to, damage to seats due to wear or abrasion, worn painted surfaces, scratched decals or windows.

Countries Other than the United States or Canada

Customers who have purchased Toro products exported from the United States or Canada should contact their Toro Distributor (Dealer) to obtain guarantee policies for your country, province, or state. If for any reason you are dissatisfied with your Distributor's service or have difficulty obtaining guarantee information, contact your Authorized Toro Service Center.

Parts

Parts scheduled for replacement as required maintenance are warranted for the period of time up to the scheduled replacement time for that part. Parts replaced under this warranty are covered for the duration of the original product warranty and become the property of Toro. Toro will make the final decision whether to repair any existing part or assembly or replace it. Toro may use remanufactured parts for warranty repairs.

Deep Cycle and Lithium-Ion Battery Warranty

Deep cycle and Lithium-Ion batteries have a specified total number of kilowatt-hours they can deliver during their lifetime. Operating, recharging, and maintenance techniques can extend or reduce total battery life. As the batteries in this product are consumed, the amount of useful work between charging intervals will slowly decrease until the battery is completely worn out. Replacement of worn out batteries, due to normal consumption, is the responsibility of the product owner. Note: (Lithium-Ion battery only): Refer to the battery warranty for additional information.

Lifetime Crankshaft Warranty (ProStripe 02657 Model Only)

The ProStripe which is fitted with a genuine Toro Friction Disc and Crank-Safe Blade Brake Clutch (integrated Blade Brake Clutch (BBC) + Friction Disc assembly) as original equipment and used by the original purchaser in accordance with recommended operating and maintenance procedures, are covered by a Lifetime Warranty against engine crankshaft bending. Machines fitted with friction washers, Blade Brake Clutch (BBC) units and other such devices are not covered by the Lifetime Crankshaft Warranty.

Maintenance is at Owner's Expense

Engine tune-up, lubrication, cleaning and polishing, replacement of filters, coolant, and completing recommended maintenance are some of the normal services Toro products require that are at the owner's expense.

General Conditions

Repair by an Authorized Toro Distributor or Dealer is your sole remedy under this warranty.

The Toro Company is not liable for indirect, incidental or consequential damages in connection with the use of the Toro Products covered by this warranty, including any cost or expense of providing substitute equipment or service during reasonable periods of malfunction or non-use pending completion of repairs under this warranty. Except for the Emissions warranty referenced below, if applicable, there is no other express warranty. All implied warranties of merchantability and fitness for use are limited to the duration of this express warranty.

Some states do not allow exclusions of incidental or consequential damages, or limitations on how long an implied warranty lasts, so the above exclusions and limitations may not apply to you. This warranty gives you specific legal rights, and you may also have other rights which vary from state to state.

Note Regarding Emissions Warranty

The Emissions Control System on your Product may be covered by a separate warranty meeting requirements established by the U.S. Environmental Protection Agency (EPA) and/or the California Air Resources Board (CARB). The hour limitations set forth above do not apply to the Emissions Control System Warranty. Refer to the Engine Emission Control Warranty Statement supplied with your product or contained in the engine manufacturer's documentation.