



Count on it.

Operator's Manual

**60in or 72in Side Discharge
Rotary Mower**

**Groundsmaster® 3200 or 3300 Series
Traction Unit**

Model No. 31970—Serial No. 400000000 and Up

Model No. 31972—Serial No. 400000000 and Up



This product complies with all relevant European directives, for details please see the separate product specific Declaration of Conformity (DOC) sheet.

⚠ WARNING

**CALIFORNIA
Proposition 65 Warning**

Use of this product may cause exposure to chemicals known to the State of California to cause cancer, birth defects, or other reproductive harm.

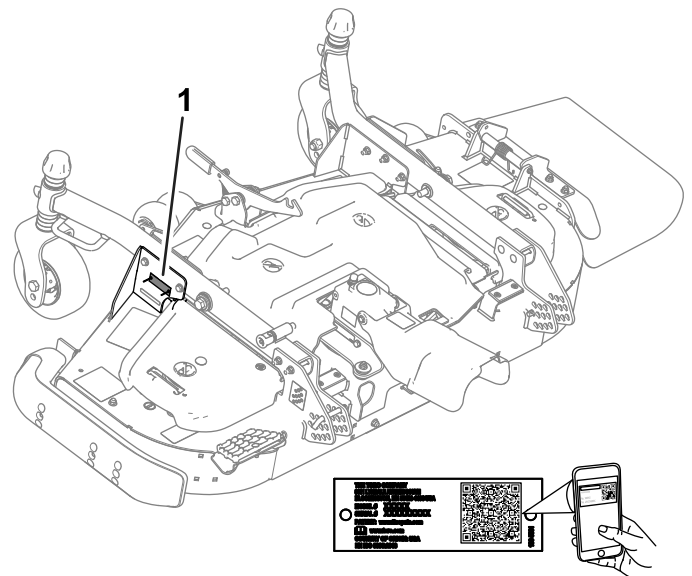

g294594

Figure 1

1. Model and serial number location

Model No. _____
Serial No. _____

Introduction

This rotary-blade lawn cutting deck is mounted to a ride-on machine and is intended to be used by professional, hired operators in commercial applications. It is primarily designed for cutting grass on well-maintained lawns in parks, sports fields, and on commercial grounds. Using this product for purposes other than its intended use could prove dangerous to you and bystanders.

Read this information carefully to learn how to operate and maintain your product properly and to avoid injury and product damage. You are responsible for operating the product properly and safely.

Visit www.Toro.com for product safety and operation training materials, accessory information, help finding a dealer, or to register your product.

Whenever you need service, genuine Toro parts, or additional information, contact an Authorized Service Dealer or Toro Customer Service and have the model and serial numbers of your product ready. [Figure 1](#) identifies the location of the model and serial numbers on the product. Write the numbers in the space provided.

Important: With your mobile device, you can scan the QR code on the serial number decal (if equipped) to access warranty, parts, and other product information.

This manual identifies potential hazards and has safety messages identified by the safety-alert symbol ([Figure 2](#)), which signals a hazard that may cause serious injury or death if you do not follow the recommended precautions.



g000502

Figure 2

1. Safety-alert symbol

This manual uses 2 words to highlight information. **Important** calls attention to special mechanical information and **Note** emphasizes general information worthy of special attention.

Contents

Safety	3
General Safety	3
Cutting Unit Safety	3
Safety and Instructional Decals	4
Setup	8
1 Preparing the Machine	9
2 Installing the CE Kit	9
3 Installing the Cutting Unit to the Traction Unit	9
4 Installing the PTO Cover	10
5 Leveling the Cutting Unit	10
6 Greasing the Machine	11
Product Overview	11
Specifications	11
Attachments/Accessories	11
Operation	12
Adjusting the Height of Cut	12
Adjusting the Cutting-Unit Pitch	13
Adjusting the Anti-Scalp Rollers	14
Adjusting the Skid	14
Adjusting the Flow Baffle	15
Positioning the Flow Baffle	15
Correcting a Cutting Unit Mismatch	15
Using the Side Discharge	16
Operating Tips	16
Maintenance	17
Recommended Maintenance Schedule(s)	17
Daily Maintenance Checklist	17
Greasing the Bearings and Bushings	18
Checking the Lubricant in the Gearbox	19
Checking the Torque of the PTO Driveshaft-to-Gearbox Fasteners	19
Removing the Cutting Unit from the Traction Unit	19
Servicing the Bushings in the Castor Arms	20
Servicing the Castor Wheels and Bearings	20
Servicing the Cutting Blades	21
Checking and Correcting Mismatch of Blades	23
Replacing the Drive Belt	23
Replacing the Grass Deflector	24
Cleaning Under the Cutting Unit	24
Storage	25

Safety

This machine has been designed in accordance with ANSI B71.4-2017 and with EN ISO 5395 when you complete the setup procedures and install the CE kit, per the Declaration of Conformity.

General Safety

This product is capable of amputating hands and feet and of throwing objects. Always follow all safety instructions to avoid serious personal injury

- Read and understand the contents of this *Operator's Manual* before starting the machine.
- Use your full attention while operating the machine. Do not engage in any activity that causes distractions; otherwise, injury or property damage may occur.
- Do not put your hands or feet near moving components of the machine.
- Do not operate the machine without all guards and other safety protective devices in place and functioning properly on the machine.
- Keep clear of any discharge opening.
- Keep bystanders and children out of the operating area. Never allow children to operate the machine.
- Before you leave the operator's position, do the following:
 - Park the machine on a level surface.
 - Lower the cutting unit(s).
 - Disengage the drives.
 - Engage the parking brake (if equipped).
 - Shut off the engine and remove the key.
 - Wait for all movement to stop.

Improperly using or maintaining this machine can result in injury. To reduce the potential for injury, comply with these safety instructions and always pay attention to the safety-alert symbol , which means Caution, Warning, or Danger—personal safety instruction. Failure to comply with these instructions may result in personal injury or death.

Cutting Unit Safety

- The cutting unit is only a complete machine when installed on a traction unit. Read the traction unit *Operator's Manual* carefully for complete instructions on the safe use of the machine.
- Stop the machine, remove the key, and wait for all moving parts to stop before inspecting the attachment after striking an object or if there is an abnormal vibration in the machine. Make all necessary repairs before resuming operation.

- Keep all parts in good working condition and all hardware tightened. Replace all worn or damaged decals.
- Use only accessories, attachments, and replacement parts approved by Toro.

Safety and Instructional Decals



Safety decals and instructions are easily visible to the operator and are located near any area of potential danger. Replace any decal that is damaged or missing.



93-6697

decal93-6697

1. Read the *Operator's Manual*.
2. Add SAE 80w-90 (API GL-5) oil every 50 hours.

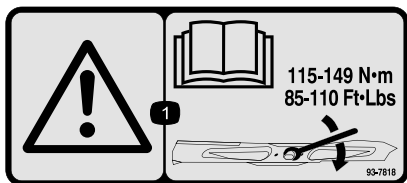

93-7818

decal93-7818

1. Warning—read the *Operator's Manual* for instructions on torquing the blade bolt/nut to 115 to 149 N·m (85 to 110 ft-lb).

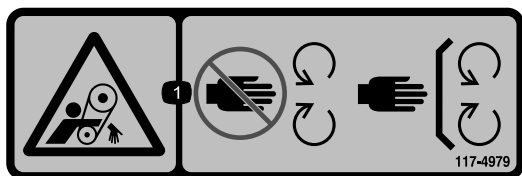

117-4979

decal117-4979

1. Entanglement hazard, belt—stay away from moving parts, keep all guards and shields in place.

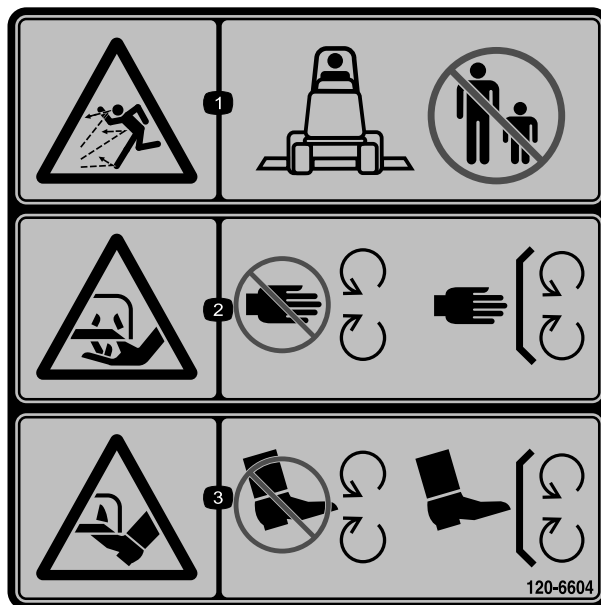

120-6604

decal120-6604

1. Thrown object hazard—keep bystanders away from the machine.
2. Cutting/dismemberment hazard of hand, mower blade—stay away from moving parts, keep all guards and shields in place.
3. Cutting/dismemberment hazard of foot, mower blade—stay away from moving parts, keep all guards and shields in place.

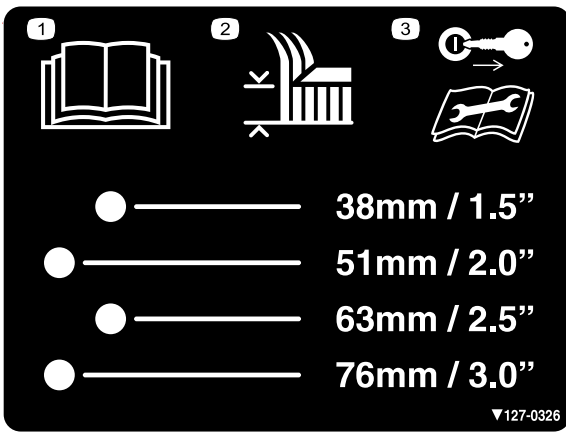

127-0326

decal127-0326

1. Read the *Operator's Manual*.
2. Height of cut
3. Remove the key and read the *Operator's Manual* before performing maintenance.

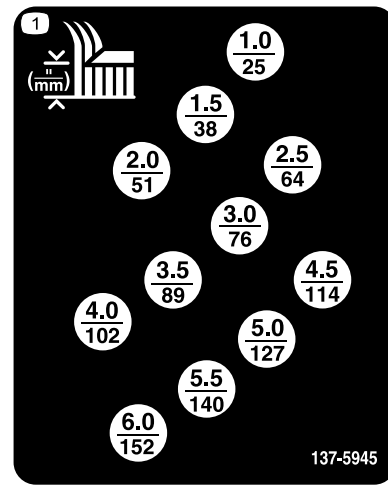

137-5945

decal137-5945

1. Height of cut (inches/millimeters)

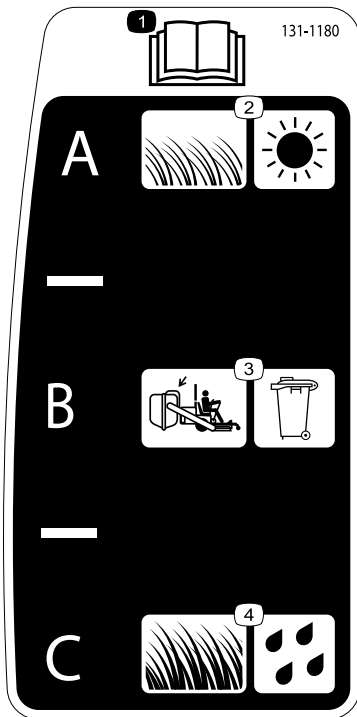

131-1180

decal131-1180

1. Read the *Operator's Manual*.
2. Short, light grass; dry conditions
3. Bagging setting
4. Tall, dense grass; wet conditions

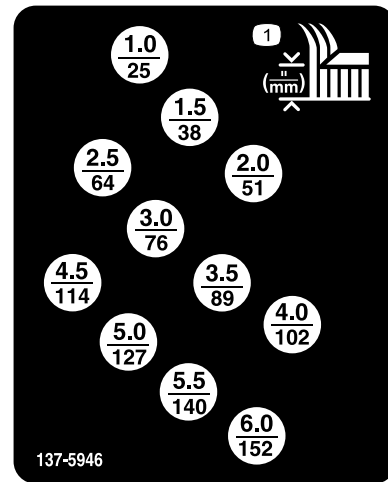

137-5946

decal137-5946

1. Height of cut (inches/millimeters)

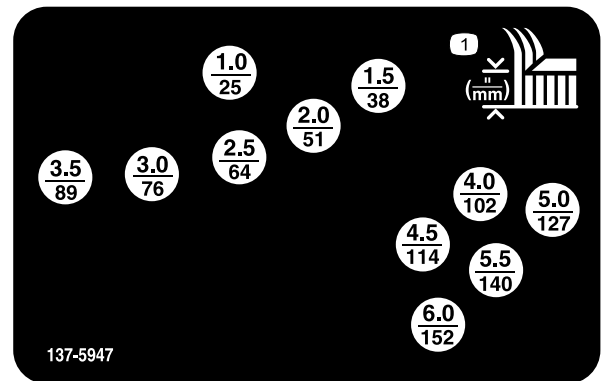

137-5947

decal137-5947

1. Height of cut (inches/millimeters)

WARNING: Cancer and Reproductive Harm - www.P65Warnings.ca.gov. For more information, please visit www.tccoCAProp65.com

133-8061

decal133-8061

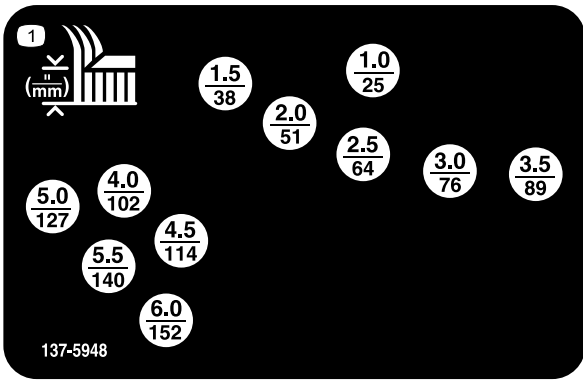

137-5948

decal137-5948

1. Height of cut (inches/millimeters)

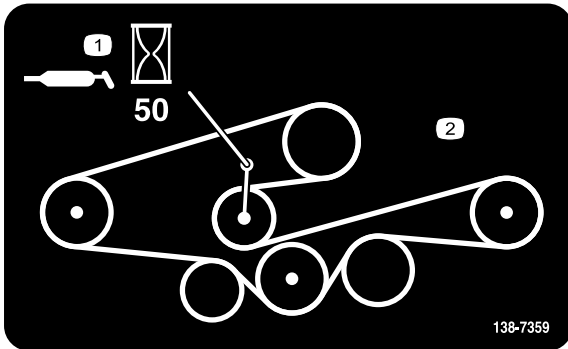

138-7359

decal138-7359

1. Grease every 50 hours.
2. Belt routing

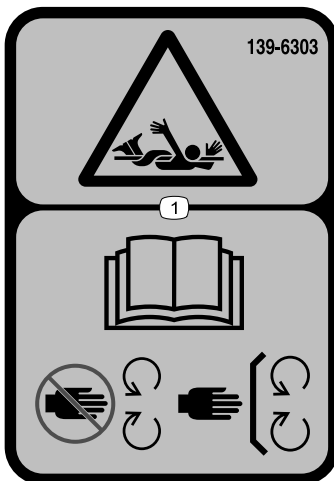

139-6303

decal139-6303

1. Entanglement hazard—read the *Operator's Manual*; stay away from moving parts; keep all guards and shields in place.

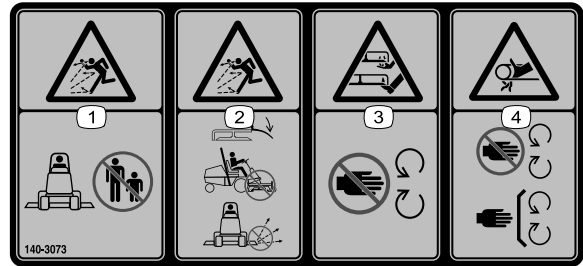

decal140-3073

140-3073

1. Thrown object hazard—keep bystanders away.
2. Thrown object hazard—keep the deflector in place; do not operate the machine without the deflector.
3. Cutting/dismemberment hazard of hand or foot, mower blade—stay away from moving parts.
4. Entanglement hazard of hand, belt—stay away from moving parts; keep all guards and shields in place.

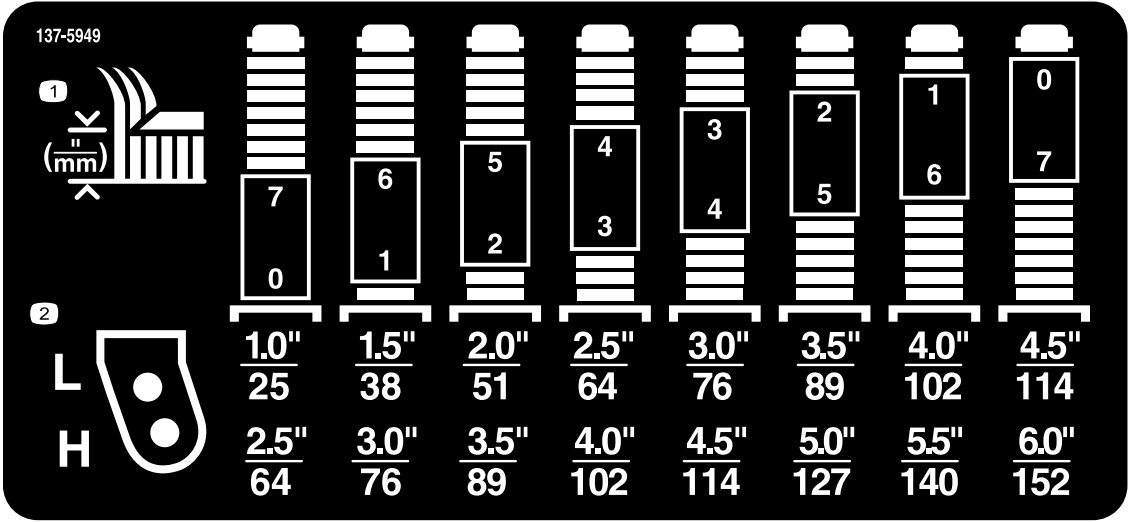

decal137-5949

137-5949

1. Height of cut

2. Mounting holes

Setup

Loose Parts

Use the chart below to verify that all parts have been shipped.

Procedure	Description	Qty.	Use
1	No parts required	–	Prepare the machine.
2	No parts required	–	Install the CE kit (if required).
3	Hex-head bolt Washer Height-of-cut pin	2 2 2	Install the cutting unit to the traction unit.
4	Shoulder bolt Spacer	2 2	Install the PTO cover.
5	No parts required	–	Level the cutting unit.
6	No parts required	–	Grease the machine.

⚠ WARNING

If you leave the key in the switch, someone could accidentally start the engine and seriously injure you or other bystanders.

Remove the key from the switch before you install the cutting unit

⚠ DANGER

If the engine is started and the PTO shaft is allowed to rotate, serious injury could result.

Do not start the engine and engage the PTO switch when the PTO shaft is not connected to the gearbox on the cutting unit.

Note: Determine the left and right sides of the machine from the normal operating position.

1

Preparing the Machine

No Parts Required

Procedure

1. Park the machine on a level surface.
2. Engage the parking brake.
3. Shut off the engine and remove the key.

2

Installing the CE Kit

If Required (CE-Compliant Countries Only)

No Parts Required

Procedure

If you use this machine in a country that complies to CE standards, install the CE Kit; refer to the kit *Installation Instructions*.

3

Installing the Cutting Unit to the Traction Unit

Parts needed for this procedure:

2	Hex-head bolt
2	Washer
2	Height-of-cut pin

Procedure

1. Park the machine on a level surface, move the lift arms to the lowest position, engage the parking brake, shut off the engine, and remove the key.
2. Position the cutting unit in front of the traction unit.
3. Slide the PTO-shaft yoke onto the gearbox shaft and secure the shafts together with 2 bolts and nuts in opposite directions ([Figure 3](#)).

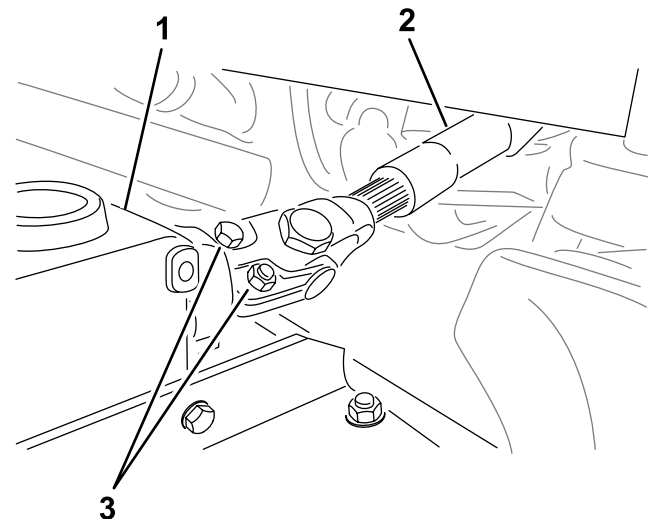

Figure 3

g299646

1. Gearbox
2. PTO shaft
3. Bolts and nuts

4. Tighten the bolts and nuts ([Figure 3](#)).
5. Push a lift arm down until the holes in the lift arm line up with the holes in the castor arms, then insert a washer and bolt through both arms.
6. Align the lift-arm holes with the castor-arm holes.
7. Use 2 hex-head bolts and 2 washers to secure the castor arms to the lift arms ([Figure 4](#)).

If you have previously used the bolts to install the cutting unit: Apply thread-locking compound to the threads of the bolts.

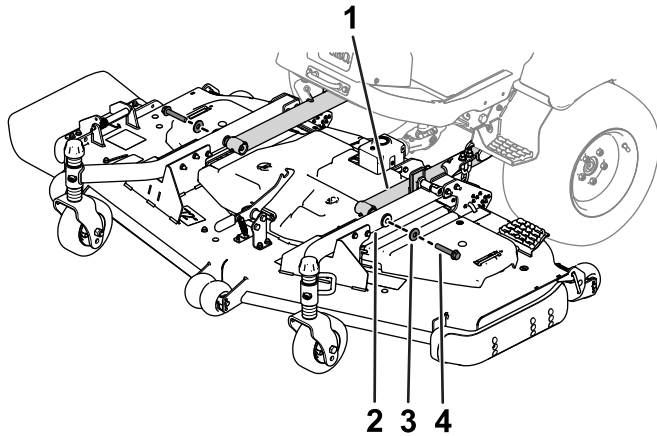

Figure 4

g296376

- | | |
|---------------|-----------|
| 1. Lift arm | 3. Washer |
| 2. Castor arm | 4. Bolt |

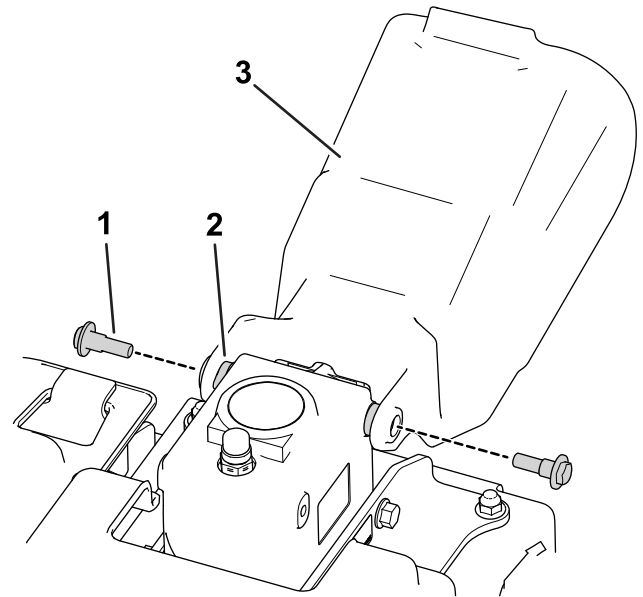

Figure 5

g296657

- | | |
|------------------|--------------|
| 1. Shoulder bolt | 3. PTO cover |
| 2. Spacer | |

8. Torque the bolts to the appropriate specification:
 - If you are using the bolts to install the cutting unit for the first time:

Torque the bolts to 256 to 313 N·m (189 to 231 ft-lb).
 - If you have previously used the bolts to install the cutting unit:

Torque the bolts to 195 to 239 N·m (144 to 176 ft-lb).
9. Set the height of cut; refer to [Adjusting the Height of Cut \(page 12\)](#).

4

Installing the PTO Cover

Parts needed for this procedure:

2	Shoulder bolt
2	Spacer

Procedure

Use 2 shoulder bolts and 2 spacers to secure the PTO cover to the gearbox ([Figure 5](#)).

5

Leveling the Cutting Unit

No Parts Required

Procedure

Note: Perform this procedure on a flat, level surface.

1. Rotate the blade on each outer spindle until the ends face forward and backward.
2. Measure from the floor to the front tip of the blade.
3. Raise the cutting unit to the TRANSPORT position.
4. Adjust the shims on the front caster forks to match the desired height of cut.
5. Rotate the blades 180° and measure from the floor to the rear-facing tip of the blade.
6. Loosen the lower jam nuts on the height-of-cut chain U-bolt ([Figure 6](#)).

Product Overview

Specifications

Note: Specifications and design are subject to change without notice.

Width of Cut	<ul style="list-style-type: none">Model No. 39190: 1.52 m (60 inches)Model No. 31972: 1.82 m (72 inches)
Height of Cut	Adjustable from 25 to 152 mm (1 to 6 inches) in 13 mm (1/2 inch) increments
Net Weight	<ul style="list-style-type: none">Model No. 31970: 204 kg (450 lb)Model No. 31972: 238 kg (525 lb)

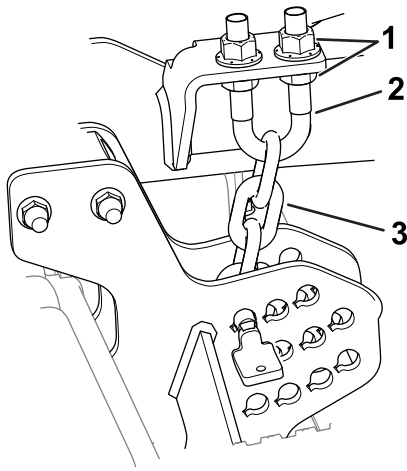

g296783

Figure 6

1. Jam nuts
2. U-bolt
3. Height-of-cut chain

7. Adjust the nuts (Figure 6) to raise or lower the rear of the cutting unit so that the tips of the rear blades are 6 to 10 mm (1/4 to 3/8 inch) higher than the front tips.
8. Tighten the jam nuts.

6

Greasing the Machine

No Parts Required

Procedure

Before operating the machine, it must be greased to ensure proper lubricating characteristics; refer to [Greasing the Bearings and Bushings \(page 18\)](#). Failure to properly grease the machine will result in premature failure of critical parts.

Attachments/Accessories

A selection of Toro approved attachments and accessories is available for use with the machine to enhance and expand its capabilities. Contact your Authorized Service Dealer or authorized Toro distributor or go to www.Toro.com for a list of all approved attachments and accessories.

To ensure optimum performance and continued safety certification of the machine, use only genuine Toro replacement parts and accessories. Replacement parts and accessories made by other manufacturers could be dangerous, and such use could void the product warranty.

Operation

Note: Determine the left and right sides of the machine from the normal operating position.

⚠ CAUTION

If you leave the key in the ignition switch, someone could accidentally start the engine and seriously injure you or other bystanders.

Remove the key from the ignition before you do any maintenance.

Adjusting the Height of Cut

The height of cut is adjustable from 25 to 152 mm (1 to 6 inches) in 13 mm (1/2 inch) increments. To adjust the height of cut:

1. Park the machine on a level surface, raise the cutting unit to the TRANSPORT position, engage the parking brake, shut off the engine, and remove the key.
2. Perform the following procedures:
 - Position the castor wheel axles in the upper or lower holes of the castor forks; refer to [Positioning the Castor-Wheel Axles \(page 12\)](#).
 - Add or remove an equal number of spacers from the castor forks; refer to [Positioning the Castor-Fork Spacers \(page 12\)](#).
 - Use the pins in height-of-cut plates to position the lift-arm chains; refer to [Positioning the Height-of-Cut Chain \(page 13\)](#).

Positioning the Castor-Wheel Axles

Position the castor-wheel axles in the same holes in both castor forks. Refer to [Figure 7](#) and [Figure 8](#) to determine the correct holes for the setting.

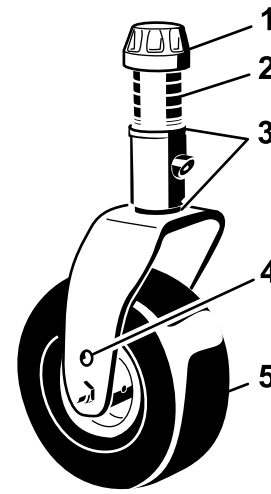

G008866

g008866

Figure 7

1. Tensioning cap
2. Spacers
3. Shims
4. Axle mounting holes
5. Castor wheel

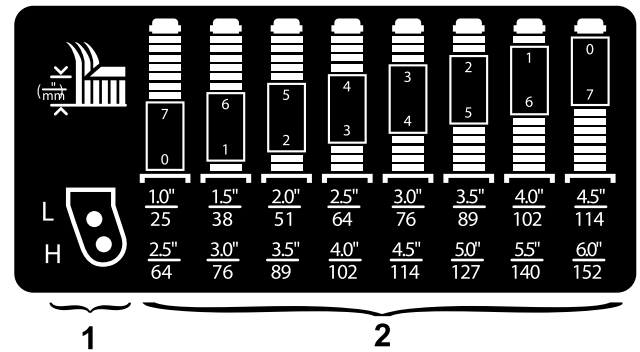

g296889

Figure 8

1. Castor wheel height-of-cut
2. Castor fork height-of-cut spacers

Note: If you operate with a 64 mm (2-1/2 inch) height of cut or higher, set the axle bolt in the lower hole to prevent grass buildup. If you detect grass buildup while operating, reverse the machine direction to pull any clippings away from the wheel/fork area.

Positioning the Castor-Fork Spacers

1. Remove the tensioning cap from the spindle shaft ([Figure 7](#)) and slide the spindle out of the castor arm. Put the 2 shims onto the spindle shaft as they were originally installed. These shims are required to achieve a level across the entire width of the cutting units.
2. Slide the appropriate number of spacers onto the spindle shaft to get the desired height of cut ([Figure 7](#)).

Refer to [Figure 8](#) to determine the combinations of spacers for your desired height-of-cut setting.

Note: You may use the shims in any combination above or below the castor-arm hub (as required) to achieve the desired height of cut or cutting-unit level.

3. Push the castor spindle through the castor arm.
4. Install the shims (as they were originally installed) and the remaining spacers onto the spindle shaft.
5. Install the tensioning cap to secure the assembly.

Positioning the Height-of-Cut Chain

1. Remove the pins that secure the height-of-cut chains to the rear of the cutting unit ([Figure 9](#)).

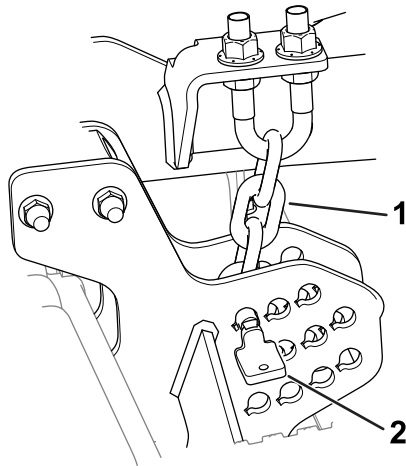

Figure 9

g296784

1. Height-of-cut chain
2. Pin

2. Refer to the height-of-cut decal to determine the appropriate hole for your desired height of cut.

Note: The decal is adjacent to each height-of-cut plate.

3. Mount the height-of-cut chains to the desired height-of-cut hole with the pin.

The pin should be installed in the lowest height-of-cut chain link. The chain should hang straight down ([Figure 9](#)); it should not be twisted.

Adjusting the Cutting-Unit Pitch

A blade pitch of 6 to 9.5 mm (1/4 to 3/8 inch) is recommended (i.e., the back of the blade plane is 6 to 9.5 mm (1/4 to 3/8 inch) higher than the front). A pitch larger than 9.5 mm (3/8 inch) results in less

required power, larger clippings, and a poorer quality of cut. A pitch less than 6 mm (1/4 inch) results in more required power, smaller clippings and a better quality of cut.

1. Park the machine on a level surface, lower the cutting unit, engage the parking brake, shut off the engine, and remove the key.
2. Set the cutting unit to the desired height-of-cut.
3. Rotate 1 blade so that it points straight forward.
4. Using a short ruler, measure from the floor to the front tip of the blade. Rotate the blade tip to the rear and measure from the floor to the tip of the blade.
5. Subtract the front dimension from the rear dimension to calculate the blade pitch.
6. Loosen the jam nuts at the top or bottom of the height-of-cut chain U-bolt ([Figure 10](#)).

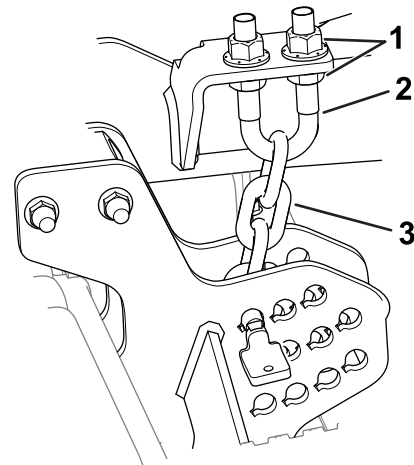

Figure 10

g296783

1. Jam nuts
2. U-bolt
3. Height-of-cut chain

7. Adjust the other set of nuts to raise or lower the rear of the cutting unit and attain the correct mower-deck pitch.
8. Tighten the jam nuts.

Adjusting the Anti-Scalp Rollers

Whenever you change the height-of-cut, adjust the height of the anti-scalp rollers (Figure 11).

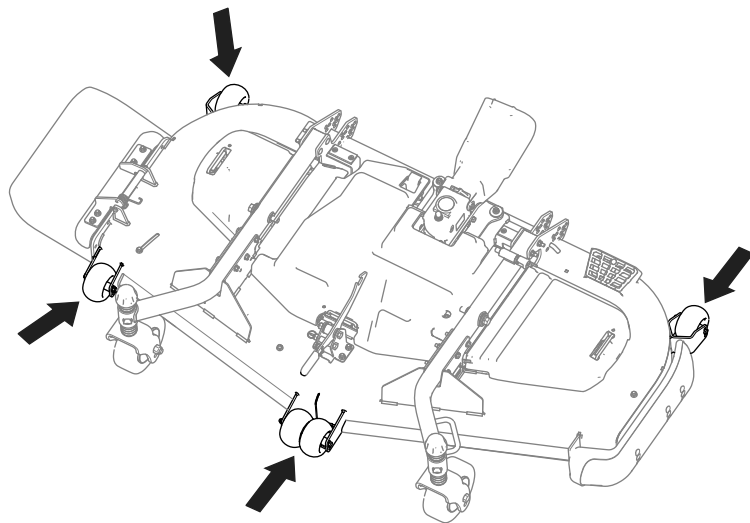

Figure 11

g297467

1. Park the machine on a level surface, lower the cutting unit, engage the parking brake, shut off the engine, and remove the key.
2. Shut off the engine, remove the key, and wait for all moving parts to stop before leaving the operating position.
3. Adjust the anti-scalp rollers as shown in Figure 12.

Note: Select a hole so the anti-scalp roller is positioned to the nearest corresponding height-of-cut desired.

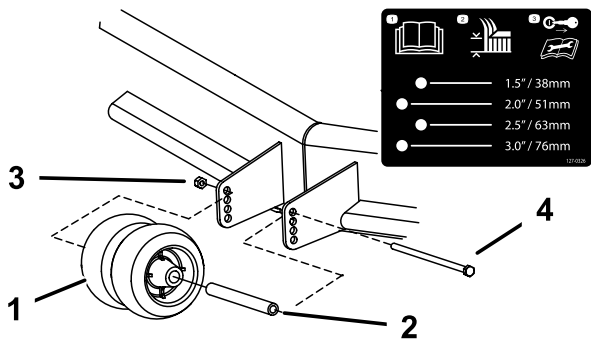

Figure 12

Front rollers shown

g296902

- | | |
|----------------------|---------------|
| 1. Anti-scalp roller | 3. Flange nut |
| 2. Bushing | 4. Bolt |

Adjusting the Skid

Mount the skid in the lower position when operating in height of cuts higher than 64 mm (2-1/2 inches) and in the higher position when operating in height of cuts lower than 64 mm (2-1/2 inches).

1. Park the machine on a level surface, lower the cutting unit, engage the parking brake, shut off the engine, and remove the key.
2. Remove the flange-head bolts and nuts from the skid.
3. Move the skid to the desired position and secure it to the cutting unit with the flange-head bolts and nuts (Figure 13).

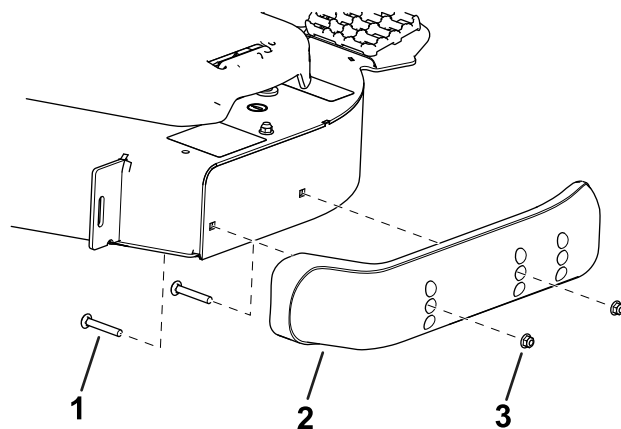

Figure 13

g295676

- | | |
|---------------------|--------|
| 1. Flange-head bolt | 3. Nut |
| 2. Skid | |

Adjusting the Flow Baffle

You can adjust the mower-discharge flow for different types of mowing conditions. Position the baffle to give the best quality of cut.

1. Park the machine on a level surface, lower the cutting unit, engage the parking brake, shut off the engine, and remove the key.
2. Loosen the nut (Figure 14).

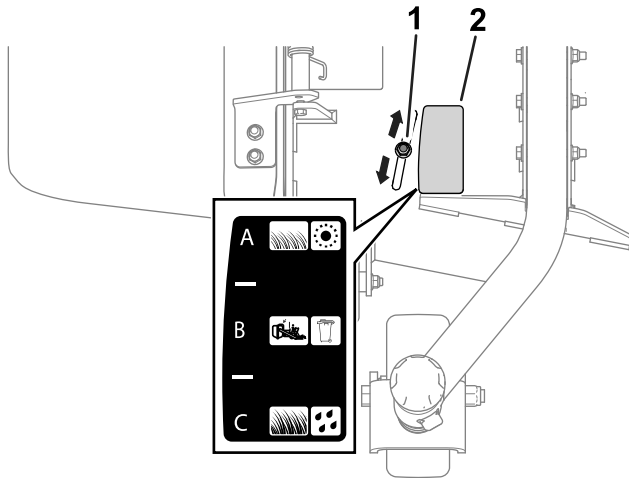

Figure 14

g295677

1. Nut
 2. Baffle-adjustment decal
-
3. Adjust the baffle and nut in the slot to the desired discharge flow; refer to [Positioning the Flow Baffle \(page 15\)](#).
 4. Tighten the nut.

Positioning the Flow Baffle

Refer to the following sections for a description of each flow-baffle position. Figure 14 illustrates each position (i.e., A, B, and C) as seen on the decal.

The following positions are only recommendations for use. Adjustments will vary by grass type, moisture content, and height of grass.

Note: If the engine power draws down and the mower ground speed is the same, open up the baffle.

Position A

This is the full rear position. The suggested use for this position is as follows.

- Use for short, light grass mowing conditions.
- Use in dry conditions.
- For smaller grass clippings.
- Propels grass clippings farther away from the mower.

Position B

Use this position when bagging. Always align it with the blower opening.

Position C

This is the full open position. The suggested use for this position is as follows.

- Use in tall, dense grass mowing conditions.
- Use in wet conditions.
- Lowers the engine power consumption.
- Allows increased ground speed in heavy conditions.

Correcting a Cutting Unit Mismatch

Due to differences in grass conditions and the counterbalance setting of the traction unit, it is advised that grass be cut and appearance checked before formal cutting is started.

1. Park the machine on a level surface, lower the cutting unit, engage the parking brake, shut off the engine, and remove the key.
2. Set the cutting unit to the desired height of cut; refer to [Adjusting the Height of Cut \(page 12\)](#).
3. Check and adjust the front and rear traction-unit tire pressure to the specified tire pressure in the traction unit *Operator's Manual*.
4. Check for bent blades; refer to [Checking for a Bent Blade \(page 21\)](#).
5. Cut grass in a test area to determine if all cutting units are cutting at the same height.
6. If cutting unit adjustments are still needed, find a flat surface using a 2 m (6 ft) or longer straight edge.
7. To ease measuring blade plane, raise the height of cut to the highest position; refer to [Adjusting the Height of Cut \(page 12\)](#).
8. Lower cutting unit onto the flat surface. Remove the covers from the top of the cutting units.
9. Rotate the blade on each spindle until the ends face forward and backward.
10. Measure from the floor to the front tip of the cutting edge.
If the measurements do not match the desired height of cut and pitch, refer to [Adjusting the Cutting-Unit Pitch \(page 13\)](#).
11. Adjust the castor-wheel spacers to match the height of cut listed on the castor-wheel decal; refer to [Positioning the Castor-Fork Spacers \(page 12\)](#).

Using the Side Discharge

The mower has a hinged grass deflector that disperses clippings to the side and down toward the turf.

▲ DANGER

Without a grass deflector, discharge cover, or complete grass catcher assembly mounted in place, you and others are exposed to blade contact and thrown debris. Contact with rotating mower blade(s) and thrown debris will cause injury or death.

- **Never remove the grass deflector from the mower because the grass deflector routes material down toward the turf. If the grass deflector is ever damaged, replace it immediately.**
- **Never put your hands or feet under the mower.**
- **Never try to clear the discharge area or mower blades unless you move the power take off (blade control switch (PTO) to the off position, rotate the ignition key to off and remove the key.**
- **Make sure that the grass deflector is in the down position.**

Operating Tips

Fast Throttle Setting/Ground Speed

To maintain enough power for the machine and deck while mowing, operate the engine at the fast throttle position and adjust your ground speed for conditions. Decrease the ground speed as the load on the cutting blades increases. Increase the ground speed as the load on the blades decreases.

Mowing Direction

Alternate mowing direction to avoid making ruts in the turf over time. This also helps disperse clippings which enhances decomposition and fertilization.

Cutting Speed

To improve cut quality, use a slower ground speed.

Avoid Cutting Too Low

If the cutting width of the cutting unit is wider than the mower you previously used, raise the cutting height to ensure that uneven turf is not cut too short.

Select the Proper Height-of-Cut Setting to Suit Conditions

Remove approximately 1 inch (25 mm) or no more than 1/3 of the grass blade when cutting. In exceptionally lush and dense grass, you may have to slow down the forward speed and/or raise the height-of-cut to the next higher setting.

Important: If cutting more than 1/3 of the grass blade off, or in sparse long grass or dry conditions, the use of flat sail blades is recommended to reduce air-borne chaff, debris, and deck drive component strain.

Long Grass

If the grass is ever allowed to grow slightly longer than normal, or if it contains a high degree of moisture, raise the cutting height higher than the usual setting and cut the grass. Then, cut the grass again using the lower, normal setting.

Keep the Cutting Unit Clean

Clean clippings and dirt from the underside of the cutting unit after each use. If grass and dirt build up inside the cutting unit, cutting quality will eventually become unsatisfactory.

To reduce the risk of fire hazard, keep the engine, muffler, battery compartment, parking brake, cutting units, and fuel storage compartment free of grass, leaves, or excessive grease. Clean up any spilled oil or fuel.

Blade Maintenance

- Maintain a sharp blade throughout the cutting season; a sharp blade cuts cleanly without tearing or shredding the grass blades. Tearing and shredding turns grass brown at the edges, which slows growth and increases the chance of disease.
- Check the blades daily for sharpness and for any wear or damage. Sharpen the blades as necessary.
- If a blade is damaged or worn, replace it immediately with a genuine Toro replacement blade. Refer to [Removing and Installing the Cutting-Unit Blade\(s\)](#) (page 21).

Maintenance

Note: Determine the left and right sides of the machine from the normal operating position.

Recommended Maintenance Schedule(s)

Maintenance Service Interval	Maintenance Procedure
After the first 2 hours	<ul style="list-style-type: none"> Tighten the castor wheel nuts.
After the first 10 hours	<ul style="list-style-type: none"> Check the PTO driveshaft-to-gearbox fastener torque. Tighten the castor wheel nuts.
After the first 50 hours	<ul style="list-style-type: none"> Change the gearbox lubricant.
Before each use or daily	<ul style="list-style-type: none"> Lubricate the castor arm bushings. Clean the cutting unit.
Every 50 hours	<ul style="list-style-type: none"> Lubricate the grease fittings. Lubricate the grease fittings immediately after every washing. Check the gearbox lubricant. Tighten the castor wheel nuts. Check the blade drive belt adjustment. Clean under the cutting unit belt covers.
Every 100 hours	<ul style="list-style-type: none"> Check the PTO driveshaft-to-gearbox fastener torque.
Every 400 hours	<ul style="list-style-type: none"> Change the gearbox lubricant.

Daily Maintenance Checklist

Duplicate this page for routine use.

Maintenance Check Item	For the week of:						
	Mon.	Tues.	Wed.	Thurs.	Fri.	Sat.	Sun.
Check the grass deflector in the down position (if applicable).							
Check the condition of the blades.							
Lubricate all the grease fittings. ¹							
Touch-up damaged paint.							
1. Immediately after every washing, regardless of the interval listed.							

Notation for Areas of Concern		
Inspection performed by:		
Item	Date	Information

⚠ CAUTION

If you leave the key in the ignition switch, someone could accidentally start the engine and seriously injure you or other bystanders.

Remove the key from the ignition before you do any maintenance.

Greasing the Bearings and Bushings

Service Interval: Every 50 hours Lubricate the grease fittings immediately after every washing.

The machine has grease fittings that you must lubricate regularly with No. 2 lithium grease.

1. Park the machine on a level surface, lower the cutting unit, engage the parking brake, shut off the engine, and remove the key.
2. Lubricate the following areas:
 - Castor fork shaft bushings (4) (Figure 15).

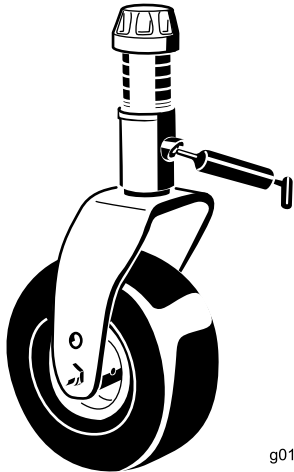

Figure 15

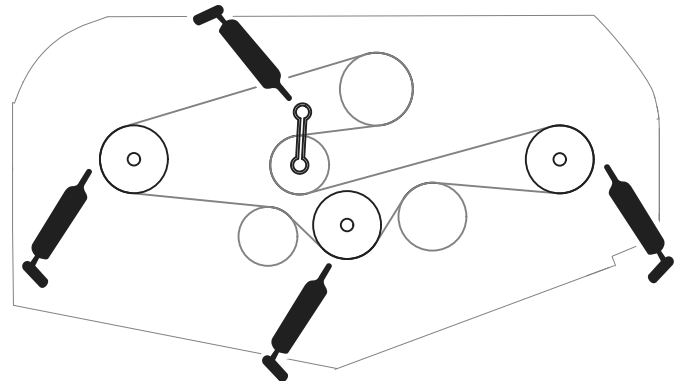

Figure 16

- Idler arm shaft bearings (Figure 16)

-
- Spindle shaft bearings (3—located under the pulley) (Figure 16)

Checking the Lubricant in the Gearbox

Service Interval: Every 50 hours

After the first 50 hours

Every 400 hours

The gearbox is designed to operate on SAE 80-90 weight gear lube. Although the gearbox comes with lubricant from the factory, check the level before operating the cutting unit. The gearbox capacity is 283 ml (15 fl oz).

1. Park the machine on a level surface, lower the cutting unit, engage the parking brake, shut off the engine, and remove the key.
2. Remove the dipstick/fill plug from the top of the gearbox (Figure 17) and ensure that the lubricant is between the marks on the dipstick. If the lubricant level is low, add enough lubricant until the level is between the marks.

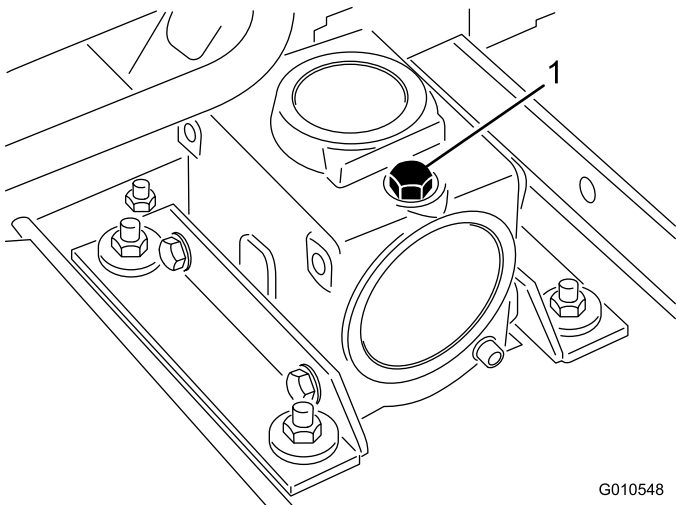

Figure 17

G010548
g010548

1. Dipstick/fill plug

3. Install the dipstick and torque it to 9 N·m (84 in-lbs).

Checking the Torque of the PTO Driveshaft-to-Gearbox Fasteners

Service Interval: After the first 10 hours

Every 100 hours

Check the torque of the fasteners that secure the PTO driveshaft to the gearbox (Figure 18); refer to the setup section in your machine *Operator's Manual* for the appropriate torque specification.

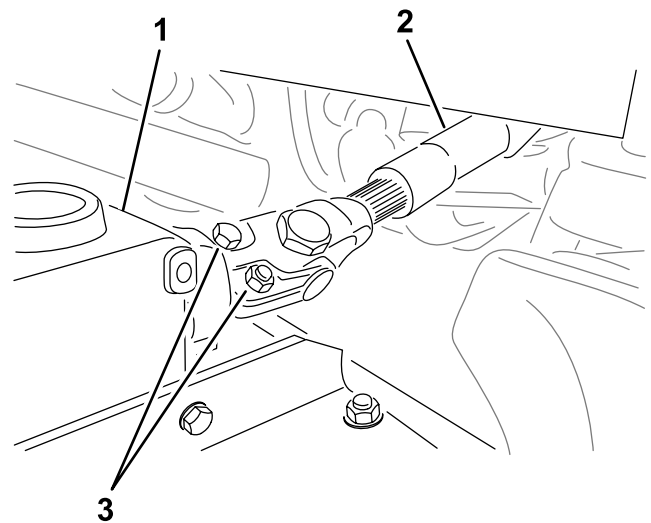

Figure 18

g299646

1. Gearbox
2. Bolts and nuts
3. PTO driveshaft

Removing the Cutting Unit from the Traction Unit

1. Park the machine on a level surface with the cutting unit raised.
2. Remove the height-of-cut pins (Figure 19) from the cutting-unit side plates.

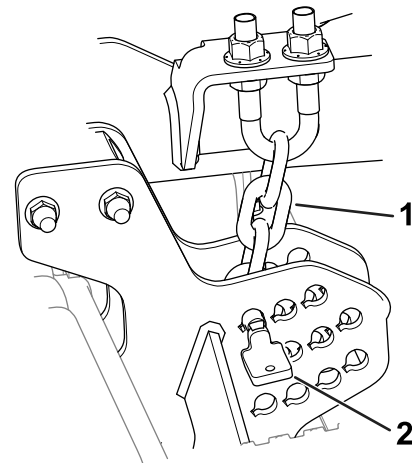

Figure 19

g296784

1. Height-of-cut chain
2. Pin

3. Lower the cutting unit, engage the parking brake, shut off the engine, and remove the key.
4. Remove the bolts and washers that secure the lift arms to the castor arms.

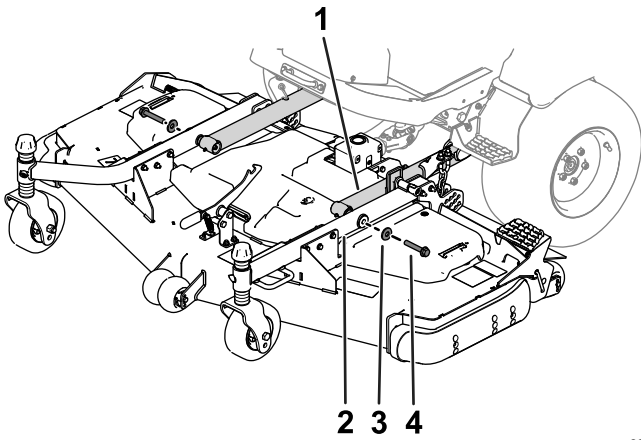

Figure 20

g296375

- | | |
|---------------|-----------|
| 1. Lift arm | 3. Washer |
| 2. Castor arm | 4. Bolt |

- Remove the bolts and nuts from the PTO shaft (Figure 21) and slide the yoke out of the gearbox.

Note: Refer to the *Operator's Manual*, to properly align the splines if you separate the drive shaft components.

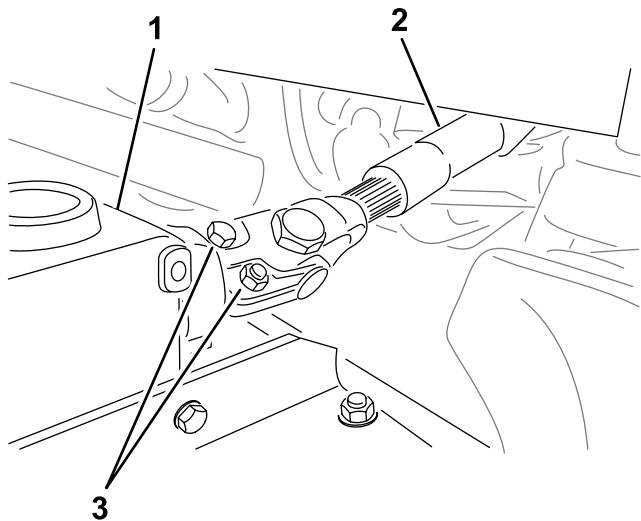

Figure 21

g299646

- | | |
|--------------|-------------------|
| 1. Gearbox | 3. Bolts and nuts |
| 2. PTO shaft | |

Servicing the Bushings in the Castor Arms

The castor arms have bushings pressed into the top and bottom of the tube, and after many hours of operation, the bushings wear.

To check the bushings, move the castor fork back and forth and from side to side. If the castor spindle is loose inside the bushings, the bushings are worn; replace them.

- Park the machine on a level surface, lower the cutting unit, engage the parking brake, shut off the engine, and remove the key.
- Remove the tensioning cap, spacer(s), and thrust washer from the top of the castor spindle.
- Pull the castor spindle out of the mounting tube. Allow the thrust washer and spacer(s) to remain on the bottom of the spindle.
- Insert a pin punch into the top or bottom of the mounting tube and drive the bushing out of the tube (Figure 22). Also, drive the other bushing out of the tube. Clean the inside of the tubes to remove dirt.

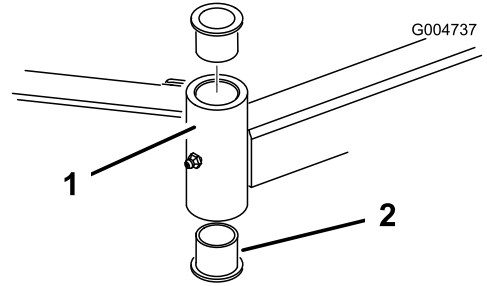

Figure 22

g004737

- | | |
|--------------------|-------------|
| 1. Castor arm tube | 2. Bushings |
|--------------------|-------------|

- Apply grease to the inside and outside of the new bushings. Use a hammer and flat plate to drive the bushings into the mounting tube.
- Inspect the castor spindle for wear and replace it if damaged.
- Push the castor spindle through the bushings and mounting tube, slide the thrust washer and spacer(s) onto the spindle, and install the tensioning cap on the castor spindle.

Servicing the Castor Wheels and Bearings

- Park the machine on a level surface, lower the cutting unit, engage the parking brake, shut off the engine, and remove the key.
- Remove the locknut from the bolt holding the castor wheel assembly between the castor fork (Figure 23). Grasp the castor wheel and slide the bolt out of the fork or pivot arm.
- Remove the bearing from the wheel hub and allow the bearing spacer to fall out (Figure 23). Remove the bearing from the opposite side of the wheel hub.
- Check the bearings, spacer, and inside of the wheel hub for wear. Replace any damaged parts.

- To assemble the castor wheel, push the bearing into the wheel hub. When installing the bearings, press on the outer race of the bearing.

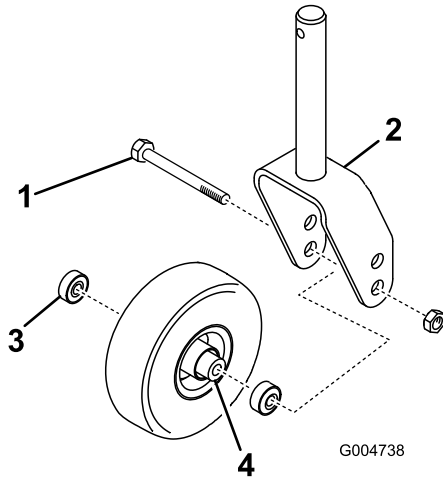

Figure 23

- | | |
|-----------------|-------------------|
| 1. Castor wheel | 3. Bearings |
| 2. Castor fork | 4. Bearing spacer |

- Slide the bearing spacer into the wheel hub. Push the other bearing into the open end of the wheel hub to captivate the bearing spacer inside the wheel hub.
- Install the castor wheel assembly between the castor fork and secure it in place with the bolt and locknut.

Servicing the Cutting Blades

Blade Safety

A worn or damaged blade can break, and a piece of the blade could be thrown toward you or bystanders, resulting in serious personal injury or death.

- Inspect the blade periodically for wear or damage.
- Use care when checking the blades. Wrap the blades or wear gloves, and use caution when servicing the blades. Only replace or sharpen the blades; never straighten or weld them.
- On multi-bladed machines, take care as rotating 1 blade can cause other blades to rotate.

Checking for a Bent Blade

After striking a foreign object, inspect the machine for damage and make repairs before starting and operating the equipment. Torque all of the spindle-pulley nuts to 176 to 203 N·m (130 to 150 ft-lb).

- Park the machine on a level surface, raise the cutting unit to the **TRANSPORT** position, engage the parking brake, shut off the engine, and remove the key.
- Raise the cutting unit to the **SERVICE** position; refer to your traction unit *Operator's Manual*.
- Rotate the blade until the ends face forward and backward and measure from the inside of the cutting unit to the cutting edge at the front of the blade (**Figure 24**).

Note: Remember this dimension.



Figure 24

- Rotate the opposite end of the blade forward and measure between the cutting unit and cutting edge of the blade at the same position as in step 3.

Note: The difference between the dimensions obtained in steps 3 and 4 must not exceed 3 mm (1/8 inch). If the dimension exceeds 3 mm (1/8 inch), the blade is bent and must be replaced; refer to [Removing and Installing the Cutting-Unit Blade\(s\)](#) (page 21).

Removing and Installing the Cutting-Unit Blade(s)

Replace the blade if it hits a solid object, is out of balance, or is bent. Always use genuine Toro replacement blades to ensure safety and optimum performance.

- Park the machine on a level surface, raise the cutting unit to the **TRANSPORT** position, engage the parking brake, shut off the engine, and remove the key.
- Raise the cutting unit to the **SERVICE** position; refer to your traction unit *Operator's Manual*.
- Grasp the end of the blade using a rag or thickly-padded glove.
- Remove the blade bolt, anti-scalp cup, and blade from the spindle shaft (**Figure 25**).

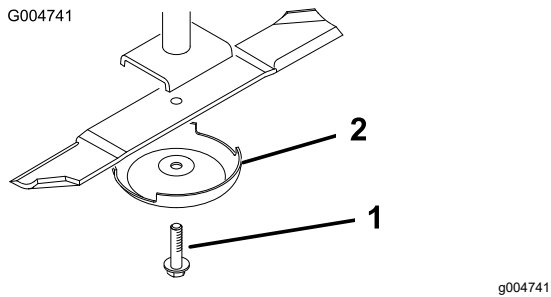

Figure 25

1. Blade bolt 2. Anti-scalp cup

5. Install the blade, anti-scalp cup, and blade bolt and tighten the blade bolt to 115 to 149 N·m (85 to 110 ft-lb).

Important: The curved part of the blade must be pointing toward the inside of the cutting unit to ensure proper cutting.

Note: After striking a foreign object, torque all spindle-pulley nuts to 115 to 149 N·m (85 to 110 ft-lb).

Inspecting and Sharpening the Cutting Unit Blade(s)

Both cutting edges and the sail, which is the turned-up portion opposite of the cutting edge, contribute to a good quality of cut.

Maintain sharp blades throughout the cutting season. Sharp blades create a clean cut without tearing or shredding the grass blades.

Check the blades for any wear or damage. The sail lifts the grass up straight, thereby producing an even cut and gradually wears down during operation.

1. Park the machine on a level surface, raise the cutting unit to the **TRANSPORT** position, engage the parking brake, shut off the engine, and remove the key.
2. Raise the cutting unit to the **SERVICE** position; refer to your traction unit *Operator's Manual*.
3. Examine the cutting ends of the blade carefully, especially where the flat and curved parts of the blade meet (**Figure 26**).

Note: Because sand and abrasive material can wear away the metal that connects the flat and curved parts of the blade, check the blade before using the mower. If you notice wear (**Figure 26**), replace the blade.

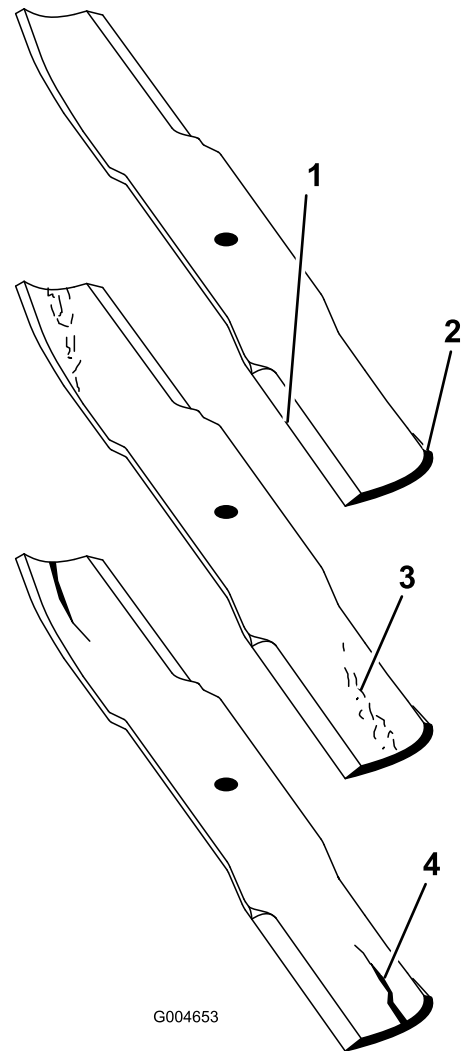

Figure 26

1. Cutting edge 3. Wear/slot forming
2. Curved area 4. Crack

4. Examine the cutting edges of all of the blades and sharpen the cutting edges if they are dull or nicked (**Figure 27**).

Note: Sharpen only the top of the cutting edge and maintain the original cutting angle to ensure sharpness (**Figure 27**). The blade remains balanced if the same amount of metal is removed from both cutting edges.

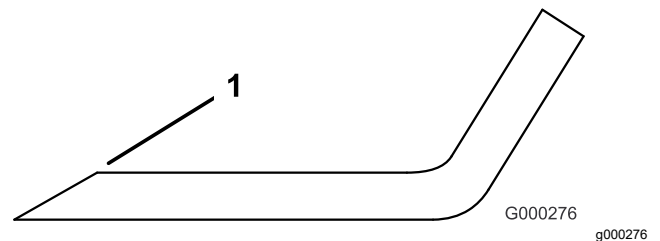

Figure 27

1. Sharpen at the original angle.

Note: Remove the blades and sharpen them on a grinder. After sharpening the cutting edges, install the blade with the anti-scalp cup and blade bolt; refer to [Inspecting and Sharpening the Cutting Unit Blade\(s\)](#) (page 22).

Checking and Correcting Mismatch of Blades

If there is mismatch between the blades, the grass will appear streaked when it is cut. This problem can be corrected by making sure that the blades are straight and all of the blades are cutting on the same plane.

1. Using a 1 m (3 ft) long carpenter's level, find a level surface on the shop floor.
2. Park the machine on a level surface, lower the cutting unit, engage the parking brake, shut off the engine, and remove the key.
3. Raise the height of cut to the highest position; refer to [Adjusting the Height of Cut](#) (page 12).
4. Remove the covers from the top of the cutting unit.
5. Rotate the blades until the ends face forward and backward. Measure from the floor to the front tip of the cutting edge. Remember this dimension. Then rotate the same blade so that the opposite end is forward, and measure again. The difference between the dimensions must not exceed 3 mm (1/8 inch). If the dimension exceeds 3 mm (1/8 inch), replace the blade because it is bent. Make sure to measure all of the blades.
6. Compare the measurements of the outer blades with the center blade. The center blade must not be more than 10 mm (3/8 inch) lower than the outer blades. If the center blade is more than 10 mm (3/8 inch) lower than the outer blades, proceed to step 7 and add shims between the spindle housing and the bottom of the cutting unit.
7. Remove the bolts, flat washers, lock washers, and nuts from the outer spindle in the area where the shims must be added. To raise or lower the blade, add a shim, Part No. 3256-24, between the spindle housing and the bottom of the cutting unit. Continue to check the alignment of the blades and add shims until the tips of the blades are within the required dimension.

Important: Do not use more than three shims at any one hole location. Use decreasing numbers of shims in adjacent holes if more than one shim is added to any one hole location.

8. Install the belt covers.

Replacing the Drive Belt

The blade drive belt, tensioned by the spring-loaded idler pulley, is very durable. However, after many hours of use, the belt will show signs of wear. Signs of a worn belt are squealing when belt is rotating, blades slipping when cutting grass, frayed edges, burn marks, and cracks. Replace the belt if any of these conditions occur.

1. Park the machine on a level surface, lower the cutting unit, engage the parking brake, shut off the engine, and remove the key.
2. Remove the belt covers from the top of the cutting unit and set the covers aside.
3. Using a torque wrench or similar tool, move the idler pulley ([Figure 28](#)) away from the drive belt to release the belt tension and allow the belt to be slipped off the gearbox pulley.

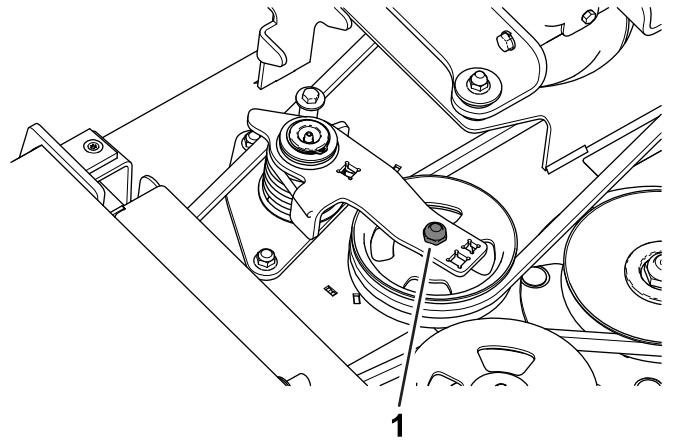

Figure 28

g295691

1. Idler pulley

4. Remove the old belt from around the spindle pulleys and idler pulley.
5. Using a torque wrench or similar tool to hold the idler pulley, route the new belt around the spindle pulleys and idler-pulley assembly as shown in [Figure 29](#).

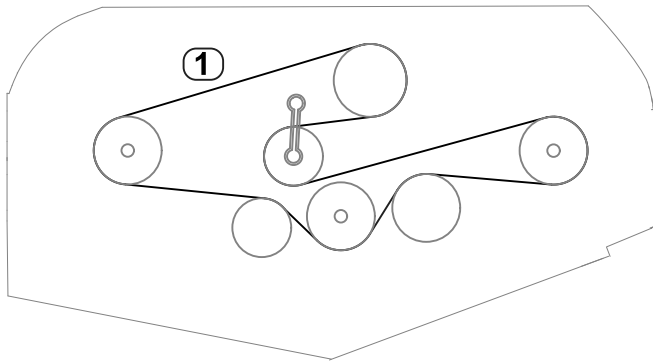

Figure 29

g295042

1. Belt routing

6. Install the belt covers.

Replacing the Grass Deflector

⚠ WARNING

An uncovered discharge opening allows the machine to throw objects toward you or bystanders, which can result in serious injury. Contact with the blade can also occur.

- Do not operate the machine unless you install a cover plate, a mulch plate, or a grass chute and catcher.
- Ensure that the grass deflector is lowered.

1. Park the machine on a level surface, lower the cutting unit, engage the parking brake, shut off the engine, and remove the key.
2. Remove the locknut, bolt, spring and spacer holding the deflector to the pivot brackets (Figure 30). Remove the damaged or worn grass deflector.
3. Place the spacer and spring onto grass deflector. Place the L-end of the spring behind the cutting unit edge.

Note: Ensure that the L-end of the spring is installed behind the cutting unit edge before installing the bolt as shown in Figure 30.

4. Install the bolt and nut. Place the J-hook end of the spring around the grass deflector (Figure 30).

Important: You must be able to lower the grass deflector into position. Lift the deflector up to test that it lowers into the full down position.

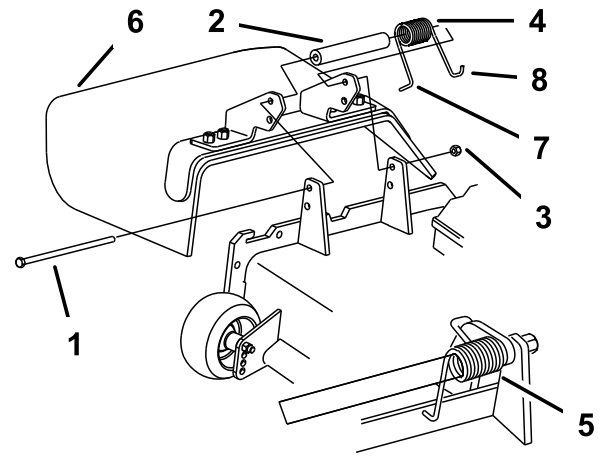

Figure 30

g297469

- | | |
|------------|---|
| 1. Bolt | 5. Spring installed |
| 2. Spacer | 6. Grass deflector |
| 3. Locknut | 7. L-end of spring, place behind the cutting unit edge before installing bolt |
| 4. Spring | 8. J-hook end of the spring |

Cleaning Under the Cutting Unit

Service Interval: Before each use or daily

Remove the grass buildup under the cutting unit daily.

1. Park the machine on a level surface, raise the cutting unit to the TRANSPORT position, engage the parking brake, shut off the engine, and remove the key.
2. Raise the cutting unit to the SERVICE position; refer to your traction unit *Operator's Manual*.
3. Thoroughly clean the underside of the cutting unit with water.

Storage

1. Park the machine on a level surface, raise the cutting unit to the TRANSPORT position, engage the parking brake, shut off the engine, and remove the key.
2. Thoroughly clean the cutting unit, paying special attention to these areas:
 - Underneath the cutting unit
 - Under the cutting unit belt covers
 - PTO shaft assembly
 - All grease fittings and pivot points
3. Check and adjust the traction-unit front and rear tire pressure; refer to the traction-unit *Operator's Manual*.
4. Remove, sharpen, and balance the cutting unit blades. Install the blades and torque the blade fasteners to 85 to 110 ft-lb (115 to 149 N·m).
5. Check all fasteners for looseness and tighten them as necessary.
6. Grease or oil all grease fittings and pivot points. Wipe off any excess lubricant.
7. Lightly sand and use touch up paint on painted areas that are scratched, chipped, or rusted. Repair any dents.

Notes:

Notes:

Notes:

Declaration of Incorporation

The Toro Company, 8111 Lyndale Ave. South, Bloomington, MN, USA declares that the following unit(s) conform(s) to the directives listed, when installed in accordance with the accompanying instructions onto certain Toro models as indicated on the relevant Declarations of Conformity.

Model No.	Serial No.	Product Description	Invoice Description	General Description	Directive
31970 with 31957	400000000 and Up	60in Side Discharge Mower	60" SD DECK, GM	60in Side Discharge Mower	2006/42/EC, 2000/14/EC
31972 with 31958	400000000 and Up	72in Side Discharge Mower	72" SD DECK, GM	72in Side Discharge Mower	2006/42/EC, 2000/14/EC

Relevant technical documentation has been compiled as required per Part B of Annex VII of 2006/42/EC.

We will undertake to transmit, in response to requests by national authorities, relevant information on this partly completed machinery. The method of transmission shall be electronic transmittal.

This machinery shall not be put into service until incorporated into approved Toro models as indicated on the associated Declaration of Conformity and in accordance with all instructions, whereby it can be declared in conformity with all relevant Directives.

Certified:



Tom Langworthy
Engineering Director
8111 Lyndale Ave. South
Bloomington, MN 55420, USA
October 11, 2022

Authorized Representative:

Marcel Dutrieux
Manager European Product Integrity
Toro Europe NV
Nijverheidsstraat 5
2260 Oevel
Belgium

UK Declaration of Incorporation

The Toro Company, 8111 Lyndale Ave. South, Bloomington, MN, USA declares that the following unit(s) conform(s) to the directives listed, when installed in accordance with the accompanying instructions onto certain Toro models as indicated on the relevant Declarations of Conformity.

Model No.	Serial No.	Product Description	Invoice Description	General Description	Regulation
31970 with 31957	400000000 and Up	60in Side Discharge Mower	60" SD DECK, GM	60in Side Discharge Mower	S.I. 2008 No. 1597 (Machinery Safety), S.I. 2001 No. 1701 (Noise)
31972 with 31958	400000000 and Up	72in Side Discharge Mower	72" SD DECK, GM	72in Side Discharge Mower	S.I. 2008 No. 1597 (Machinery Safety), S.I. 2001 No. 1701 (Noise)

Relevant technical documentation has been compiled as required per Schedule 10 of S.I. 2008 No. 1597.

We will undertake to transmit, in response to requests by national authorities, relevant information on this partly completed machinery. The method of transmission shall be electronic transmittal.

This machinery shall not be put into service until incorporated into approved Toro models as indicated on the associated Declaration of Conformity and in accordance with all instructions, whereby it can be declared in conformity with all relevant Directives.

This declaration has been issued under the sole responsibility of the manufacturer.
The object of the declaration is in conformity with relevant UK legislation.



Tom Langworthy
Engineering Director
8111 Lyndale Ave. South
Bloomington, MN 55420, USA
October 11, 2022

Authorized Representative:

Marcel Dutrieux
Manager European Product Integrity
Toro U.K. Limited
Spellbrook Lane West
Bishop's Stortford
CM23 4BU
United Kingdom

California Proposition 65 Warning Information

What is this warning?

You may see a product for sale that has a warning label like the following:



WARNING: Cancer and Reproductive Harm—www.p65Warnings.ca.gov.

What is Prop 65?

Prop 65 applies to any company operating in California, selling products in California, or manufacturing products that may be sold in or brought into California. It mandates that the Governor of California maintain and publish a list of chemicals known to cause cancer, birth defects, and/or other reproductive harm. The list, which is updated annually, includes hundreds of chemicals found in many everyday items. The purpose of Prop 65 is to inform the public about exposure to these chemicals.

Prop 65 does not ban the sale of products containing these chemicals but instead requires warnings on any product, product packaging, or literature with the product. Moreover, a Prop 65 warning does not mean that a product is in violation of any product safety standards or requirements. In fact, the California government has clarified that a Prop 65 warning "is not the same as a regulatory decision that a product is 'safe' or 'unsafe.'" Many of these chemicals have been used in everyday products for years without documented harm. For more information, go to <https://oag.ca.gov/prop65/faqs-view-all>.

A Prop 65 warning means that a company has either (1) evaluated the exposure and has concluded that it exceeds the "no significant risk level"; or (2) has chosen to provide a warning based on its understanding about the presence of a listed chemical without attempting to evaluate the exposure.

Does this law apply everywhere?

Prop 65 warnings are required under California law only. These warnings are seen throughout California in a wide range of settings, including but not limited to restaurants, grocery stores, hotels, schools, and hospitals, and on a wide variety of products. Additionally, some online and mail order retailers provide Prop 65 warnings on their websites or in catalogs.

How do the California warnings compare to federal limits?

Prop 65 standards are often more stringent than federal and international standards. There are various substances that require a Prop 65 warning at levels that are far lower than federal action limits. For example, the Prop 65 standard for warnings for lead is 0.5 µg/day, which is well below the federal and international standards.

Why don't all similar products carry the warning?

- Products sold in California require Prop 65 labelling while similar products sold elsewhere do not.
- A company involved in a Prop 65 lawsuit reaching a settlement may be required to use Prop 65 warnings for its products, but other companies making similar products may have no such requirement.
- The enforcement of Prop 65 is inconsistent.
- Companies may elect not to provide warnings because they conclude that they are not required to do so under Prop 65; a lack of warnings for a product does not mean that the product is free of listed chemicals at similar levels.

Why does Toro include this warning?

Toro has chosen to provide consumers with as much information as possible so that they can make informed decisions about the products they buy and use. Toro provides warnings in certain cases based on its knowledge of the presence of one or more listed chemicals without evaluating the level of exposure, as not all the listed chemicals provide exposure limit requirements. While the exposure from Toro products may be negligible or well within the "no significant risk" range, out of an abundance of caution, Toro has elected to provide the Prop 65 warnings. Moreover, if Toro does not provide these warnings, it could be sued by the State of California or by private parties seeking to enforce Prop 65 and subject to substantial penalties.



The Toro Warranty

Two-Year or 1,500 Hours Limited Warranty

Conditions and Products Covered

The Toro Company warrants your Toro Commercial product ("Product") to be free from defects in materials or workmanship for 2 years or 1,500 operational hours*, whichever occurs first. This warranty is applicable to all products with the exception of Aerators (refer to separate warranty statements for these products). Where a warrantable condition exists, we will repair the Product at no cost to you including diagnostics, labor, parts, and transportation. This warranty begins on the date the Product is delivered to the original retail purchaser.

* Product equipped with an hour meter.

Instructions for Obtaining Warranty Service

You are responsible for notifying the Commercial Products Distributor or Authorized Commercial Products Dealer from whom you purchased the Product as soon as you believe a warrantable condition exists. If you need help locating a Commercial Products Distributor or Authorized Dealer, or if you have questions regarding your warranty rights or responsibilities, you may contact us at:

Toro Commercial Products Service Department
8111 Lyndale Avenue South
Bloomington, MN 55420-1196

952-888-8801 or 800-952-2740
E-mail: commercial.warranty@toro.com

Owner Responsibilities

As the product owner, you are responsible for required maintenance and adjustments stated in your *Operator's Manual*. Repairs for product issues caused by failure to perform required maintenance and adjustments are not covered under this warranty.

Items and Conditions Not Covered

Not all product failures or malfunctions that occur during the warranty period are defects in materials or workmanship. This warranty does not cover the following:

- Product failures which result from the use of non-Toro replacement parts, or from installation and use of add-on, or modified non-Toro branded accessories and products.
- Product failures which result from failure to perform recommended maintenance and/or adjustments.
- Product failures which result from operating the Product in an abusive, negligent, or reckless manner.
- Parts consumed through use that are not defective. Examples of parts which are consumed, or used up, during normal Product operation include, but are not limited to, brake pads and linings, clutch linings, blades, reels, rollers and bearings (sealed or greasable), bed knives, spark plugs, castor wheels and bearings, tires, filters, belts, and certain sprayer components such as diaphragms, nozzles, flow meters, and check valves.
- Failures caused by outside influence, including, but not limited to, weather, storage practices, contamination, use of unapproved fuels, coolants, lubricants, additives, fertilizers, water, or chemicals.
- Failure or performance issues due to the use of fuels (e.g. gasoline, diesel, or biodiesel) that do not conform to their respective industry standards.
- Normal noise, vibration, wear and tear, and deterioration. Normal "wear and tear" includes, but is not limited to, damage to seats due to wear or abrasion, worn painted surfaces, scratched decals or windows.

Countries Other than the United States or Canada

Customers who have purchased Toro products exported from the United States or Canada should contact their Toro Distributor (Dealer) to obtain guarantee policies for your country, province, or state. If for any reason you are dissatisfied with your Distributor's service or have difficulty obtaining guarantee information, contact your Authorized Toro Service Center.

Parts

Parts scheduled for replacement as required maintenance are warranted for the period of time up to the scheduled replacement time for that part. Parts replaced under this warranty are covered for the duration of the original product warranty and become the property of Toro. Toro will make the final decision whether to repair any existing part or assembly or replace it. Toro may use remanufactured parts for warranty repairs.

Deep Cycle and Lithium-Ion Battery Warranty

Deep cycle and Lithium-Ion batteries have a specified total number of kilowatt-hours they can deliver during their lifetime. Operating, recharging, and maintenance techniques can extend or reduce total battery life. As the batteries in this product are consumed, the amount of useful work between charging intervals will slowly decrease until the battery is completely worn out. Replacement of worn out batteries, due to normal consumption, is the responsibility of the product owner. Note: (Lithium-Ion battery only): Refer to the battery warranty for additional information.

Lifetime Crankshaft Warranty (ProStripe 02657 Model Only)

The ProStripe which is fitted with a genuine Toro Friction Disc and Crank-Safe Blade Brake Clutch (integrated Blade Brake Clutch (BBC) + Friction Disc assembly) as original equipment and used by the original purchaser in accordance with recommended operating and maintenance procedures, are covered by a Lifetime Warranty against engine crankshaft bending. Machines fitted with friction washers, Blade Brake Clutch (BBC) units and other such devices are not covered by the Lifetime Crankshaft Warranty.

Maintenance is at Owner's Expense

Engine tune-up, lubrication, cleaning and polishing, replacement of filters, coolant, and completing recommended maintenance are some of the normal services Toro products require that are at the owner's expense.

General Conditions

Repair by an Authorized Toro Distributor or Dealer is your sole remedy under this warranty.

The Toro Company is not liable for indirect, incidental or consequential damages in connection with the use of the Toro Products covered by this warranty, including any cost or expense of providing substitute equipment or service during reasonable periods of malfunction or non-use pending completion of repairs under this warranty. Except for the Emissions warranty referenced below, if applicable, there is no other express warranty. All implied warranties of merchantability and fitness for use are limited to the duration of this express warranty.

Some states do not allow exclusions of incidental or consequential damages, or limitations on how long an implied warranty lasts, so the above exclusions and limitations may not apply to you. This warranty gives you specific legal rights, and you may also have other rights which vary from state to state.

Note Regarding Emissions Warranty

The Emissions Control System on your Product may be covered by a separate warranty meeting requirements established by the U.S. Environmental Protection Agency (EPA) and/or the California Air Resources Board (CARB). The hour limitations set forth above do not apply to the Emissions Control System Warranty. Refer to the Engine Emission Control Warranty Statement supplied with your product or contained in the engine manufacturer's documentation.