



**Count on it.**

**Operator's Manual**

**High-Speed or High-Torque  
Trencher Head**

**Compact Tool Carrier**

Model No. 22473—Serial No. 404310000 and Up

Model No. 22474—Serial No. 404200000 and Up



This product complies with all relevant European directives. For details, please see the Declaration of Incorporation (DOI) at the back of this publication.

**⚠ WARNING**

**CALIFORNIA  
Proposition 65 Warning**

**Use of this product may cause exposure to chemicals known to the State of California to cause cancer, birth defects, or other reproductive harm.**

# Introduction

The trencher head attachment is intended to be used on a Toro tool carrier with a variety of booms and chains. It is designed primarily to dig trenches in soil to facilitate the burying of cabling and piping. It not intended for use in cutting hard materials such as wood or concrete. Using this product for purposes other than its intended use could prove dangerous to you and bystanders.

Read this information carefully to learn how to operate and maintain your product properly and to avoid injury and product damage. You are responsible for operating the product properly and safely.

Visit [www.Toro.com](http://www.Toro.com) for product safety and operation training materials, accessory information, help finding a dealer, or to register your product

Whenever you need service, genuine Toro parts, or additional information, contact an Authorized Service Dealer or Toro Customer Service and have the model and serial numbers of your product ready. [Figure 1](#) identifies the location of the model and serial numbers on the product. Write the numbers in the space provided.

**Important:** With your mobile device, you can scan the QR code on the serial number decal (if equipped) to access warranty, parts, and other product information.

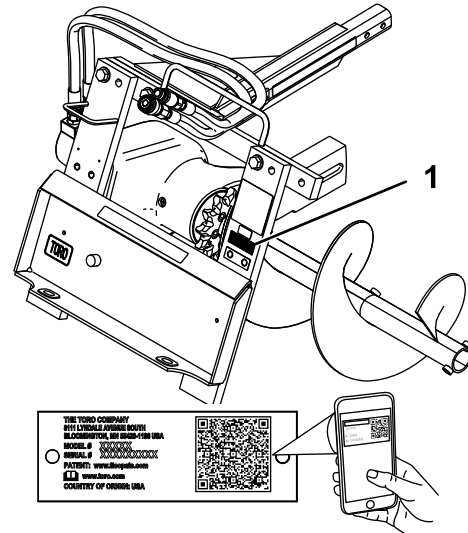

**Figure 1**

g244478

1. Model and serial number location

Model No. _____
Serial No. _____

This manual identifies potential hazards and has safety messages identified by the safety-alert symbol ([Figure 2](#)), which signals a hazard that may cause serious injury or death if you do not follow the recommended precautions.



**Figure 2**

g000502

1. Safety-alert symbol

This manual uses 2 words to highlight information. **Important** calls attention to special mechanical information and **Note** emphasizes general information worthy of special attention.

# Contents

Safety .....	3
General Safety .....	3
Slope Safety .....	4
Trencher Safety .....	4
Maintenance and Storage Safety .....	4
Safety and Instructional Decals .....	5
Setup .....	6
1 Installing the Boom and Digging Chain .....	6
2 Installing the Safety Bar .....	7
3 Installing the Spoils Auger .....	7
4 Checking the Bearing Case Lube Level .....	8
Product Overview .....	9
Specifications .....	9
Operation .....	9
Installing and Removing the Attachment .....	9
Digging a Trench .....	10
Offsetting the Trencher .....	10
Transport Position .....	11
Transporting the Trencher on a Trailer .....	11
Operating Tips .....	12
Maintenance .....	13
Recommended Maintenance Schedule(s) .....	13
Greasing the Trencher .....	13
Servicing the Bearing Case Lube .....	14
Adjusting the Digging Chain Tension .....	14
Flipping a Worn Boom .....	15
Replacing the Digging Teeth .....	15
Replacing the Drive Sprocket .....	15
Storage .....	16

# Safety

## **⚠ DANGER**

**There may be buried utility lines in the work area. Digging into them may cause a shock or an explosion.**

**Have the property or work area marked for buried lines and do not dig in marked areas. Contact your local marking service or utility company to have the property marked (for example, in the US, call 811 or in Australia, call 1100 for the nationwide marking service).**

## General Safety

Always follow all safety instructions to avoid serious injury or death.

- Do not exceed the rated operating capacity, as the machine may become unstable, which may result in loss of control.
- **Do not transport an attachment with the arms raised or extended (if applicable).** Always transport the attachment close to the ground; refer to [Transport Position \(page 11\)](#).
- Have the property or work area marked for buried lines and other objects, and do not dig in marked areas.
- Read and understand the content of this *Operator's Manual* before starting the machine.
- Use your full attention while operating the machine. Do not engage in any activity that causes distractions; otherwise, injury or property damage may occur.
- Never allow children or untrained people to operate the machine.
- Keep your hands and feet away from the moving components and attachments.
- Do not operate the machine without the guards and other safety protective devices in place and working on the machine.
- Keep bystanders and pets away from the machine.
- Stop the machine, shut off the machine, and remove the key before servicing, fueling, or unclogging the machine.

Improperly using or maintaining this machine can result in injury. To reduce the potential for injury, comply with these safety instructions and always pay attention to the safety-alert symbol **⚠**, which means Caution, Warning, or Danger—personal safety instruction. Failure to comply with these instructions may result in personal injury or death.

## Slope Safety

- **Operate the machine up and down slopes with the heavy end of the machine uphill.** Weight distribution changes with attachments. This attachment makes the front of machine the heavy end.
- Raising or extending (if applicable) the loader arms on a slope affects the stability of the machine. Keep the loader arms in the lowered and retracted position when on slopes..
- Slopes are a major factor related to loss of control and tip-over accidents, which can result in severe injury or death. Operating the machine on any slope or uneven terrain requires extra caution.
- Establish your own procedures and rules for operating on slopes. These procedures must include surveying the site to determine which slopes are safe for machine operation. Always use common sense and good judgment when performing this survey.
- Slow down and use extra care on hillsides. Ground conditions can affect the stability of the machine.
- Avoid starting or stopping on a slope. If the machine loses traction, proceed slowly, straight down the slope.
- Avoid turning on slopes. If you must turn, turn slowly and keep the heavy end of the machine uphill.
- Keep all movements on slopes slow and gradual. Do not make sudden changes in speed or direction.
- If you feel uneasy operating the machine on a slope, do not do it.
- Watch for holes, ruts, or bumps, as uneven terrain could overturn the machine. Tall grass can hide obstacles.
- Use caution when operating on wet surfaces. Reduced traction could cause sliding.
- Evaluate the area to ensure that the ground is stable enough to support the machine.
- Use caution when operating the machine near the following:
  - Drop-offs
  - Ditches
  - Embankments
  - Bodies of water

The machine could suddenly roll over if a track goes over the edge or the edge caves in. Maintain a safe distance between the machine and any hazard.

- Do not remove or add attachments on a slope.
- Do not park the machine on a hillside or slope.

## Trencher Safety

- Keep your hands, feet, and any other part of your body or clothing away from moving teeth, auger, or other parts.
- For wheeled traction units, use the counterweight on the traction unit when using the attachment.
- Use a safety-bar extension on a boom over 61 cm (2 ft).
- Look behind and down before backing up to ensure that the path is clear.
- Stop the digging chain when you are not digging.
- Always lower the attachment and shut off the machine each time you leave the operating position.
- Clean soil from the trencher before transporting it.

## Maintenance and Storage Safety

- Check fasteners at frequent intervals for proper tightness to ensure that the equipment is in safe operating condition.
- Refer to this *Operator's Manual* for important details if you store the attachment for an extended period of time.
- Maintain or replace safety and instruction labels, as necessary.

# Safety and Instructional Decals



Safety decals and instructions are easily visible to the operator and are located near any area of potential danger. Replace any decal that is damaged or missing.



99-9952

decal99-9952

1. Cutting/dismemberment hazard, auger and chain—keep bystanders away; stay away from moving parts.
2. Warning—remove the key before performing maintenance.
3. Explosion hazard; electrical shock hazard—do not operate if power lines may be present.



99-9953

decal99-9953

1. Explosion and/or electric shock hazard—do not dig in areas with buried gas or power lines.

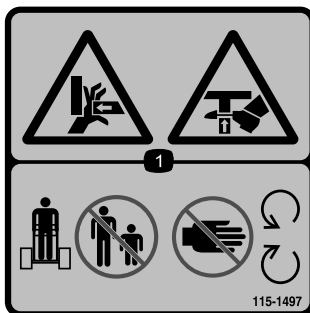

115-1497

decal115-1497

1. Crushing hazard of hand; crushing hazard of foot—keep bystanders away from the machine; keep away from moving parts.

**WARNING:** Cancer and Reproductive Harm - [www.P65Warnings.ca.gov](http://www.P65Warnings.ca.gov).  
For more information, please visit [www.tcoCAProp65.com](http://www.tcoCAProp65.com)

decal133-8061

133-8061

# Setup

## Loose Parts

Use the chart below to verify that all parts have been shipped.

Procedure	Description	Qty.	Use
<b>1</b>	Boom assembly (sold separately)	1	Install the boom and digging chain.
	Chain assembly (sold separately)	1	
<b>2</b>	Safety bar	1	Install the safety bar.
	Safety bar extension (with booms over 61 cm (2 ft) only)	1	
	Bolts (with booms over 61 cm (2 ft) only)	2	
	Locknuts (with booms over 61 cm (2 ft) only)	2	
<b>3</b>	No parts required	–	Install the spoils auger.
<b>4</b>	No parts required	–	Check the bearing case lube level.

# 1

## Installing the Boom and Digging Chain

Parts needed for this procedure:

1	Boom assembly (sold separately)
1	Chain assembly (sold separately)

## Procedure

1. Raise the trencher about 15 cm (6 inches) off the ground.
2. Shut off the engine and remove the key.
3. Remove the bolt and nut securing the spoils auger and remove the auger ([Figure 3](#)).

**Note:** Retain the bolts and nuts for installation later.

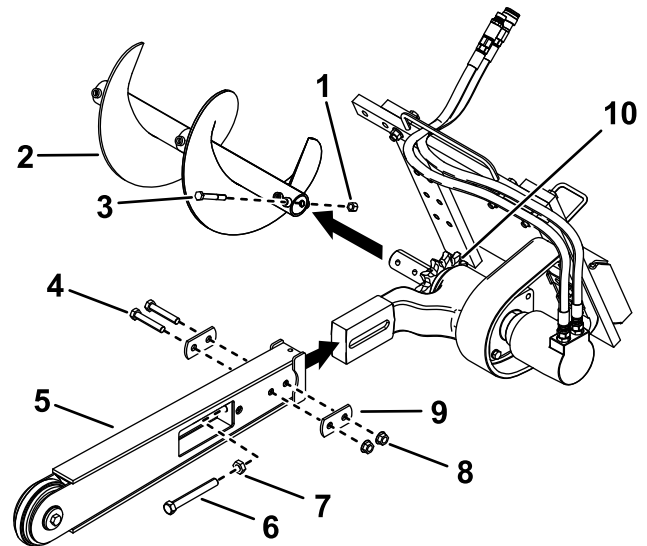

**Figure 3**

g244576

- |                              |                    |
|------------------------------|--------------------|
| 1. Locknut (1/2 inch)        | 6. Adjusting bolt  |
| 2. Spoils auger              | 7. Jam nut         |
| 3. Bolt (1/2 x 3-3/4 inches) | 8. Nut (5/8 inch)  |
| 4. Bolt (5/8 x 3-1/2 inches) | 9. Double washer   |
| 5. Boom                      | 10. Drive sprocket |

4. Remove the 2 bolts (5/8 x 3-1/2 inches), 2 nuts (5/8 inch), and 2 double washers from the sides of the boom ([Figure 3](#)).
5. Loosen the adjusting bolt and jam nut ([Figure 3](#)).
6. Slide the boom over the arm on the drive head.
7. Install the bolts, nuts, and double washers removed previously from the boom, but do not tighten them.

- If the chain is not connected, connect the links by pressing or hammering the clevis pin supplied with the chain through the links.

**Important:** To avoid bending the chain links, place blocks under and between the links when hammering the clevis pin.

- Secure the clevis pin with the cotter pin supplied with the chain.
- Loop the digging chain over the auger drive shaft and onto the drive sprocket, ensuring that the digging teeth point forward on the upper span.
- Set the upper span of the chain into place on the trencher boom, then wrap the chain around the roller at the end of the boom.
- Thread the adjustment bolt into the boom and turn it in until there is 3.8 to 6.3 cm (1-1/2 to 2-1/2 inches) of slack in the chain on the bottom span.
- Thread the jam nut down the adjusting bolt and tighten it securely against the boom.
- Torque the 2 bolts and nuts securing the boom to 183 to 223 N·m (135 to 165 ft-lb).

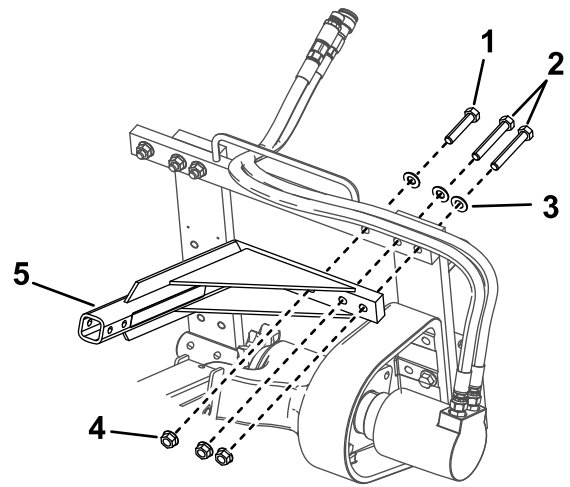

g244621

**Figure 4**

- Bolt (5/8 x 3 inches)
- Bolt (5/8 x 4 inches)
- Washer
- Nut (5/8 inch)
- Safety bar

# 2

## Installing the Safety Bar

### Parts needed for this procedure:

1	Safety bar
1	Safety bar extension (with booms over 61 cm (2 ft) only)
2	Bolts (with booms over 61 cm (2 ft) only)
2	Locknuts (with booms over 61 cm (2 ft) only)

### Procedure

- Remove the bolts, washers, and flange nuts from the upper left corner of the trencher frame (Figure 4).

- Using the fasteners removed previously, install the trencher safety bar as illustrated in (Figure 4).
- Torque the bolts and nuts to 257 to 311 N·m (190 to 230 ft-lb).
- If you have a boom over 61 cm (2 ft), secure the safety-bar extension (supplied with the boom) over the end of the safety bar and secure it using the 2 bolts and locknuts supplied with the extension (Figure 5).

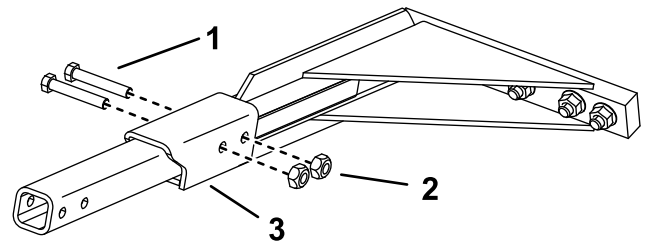

g244620

**Figure 5**

Safety-bar extension for 91 cm (3 ft) shown.

- Bolt (1/2 x 3 inch)
- Nut (1/2 inch)
- Safety-bar extension

# 3

## Installing the Spoils Auger

No Parts Required

### Procedure

Before operating the trencher, install and position the spoils auger to work correctly with the digging chain configuration you are using. If you do not position the spoils auger correctly, you could damage the trencher.

1. Use the bolt and nut removed from the auger previously to secure it in the correct holes, as described in the following list:

**Note:** Refer to (Figure 6) when performing this procedure.

- 10 cm (4 inch) chain configuration

Using the hole closest to the auger blade in the end of the auger with 2 holes, connect the auger to the inner hole on the shaft.

- 15 cm (6 inch) chain configuration

Using the hole farthest from the auger blade in the end of the auger with 2 holes, connect the auger to the inner hole on the shaft.

- 20 cm (8 inch) chain configuration

Using the end of the auger with 1 hole, connect the auger to the inner hole on the shaft.

- 25 or 30 cm (12 inch) chain configuration

Using the end of the auger with 1 hole, connect the auger to the outer hole on the shaft.

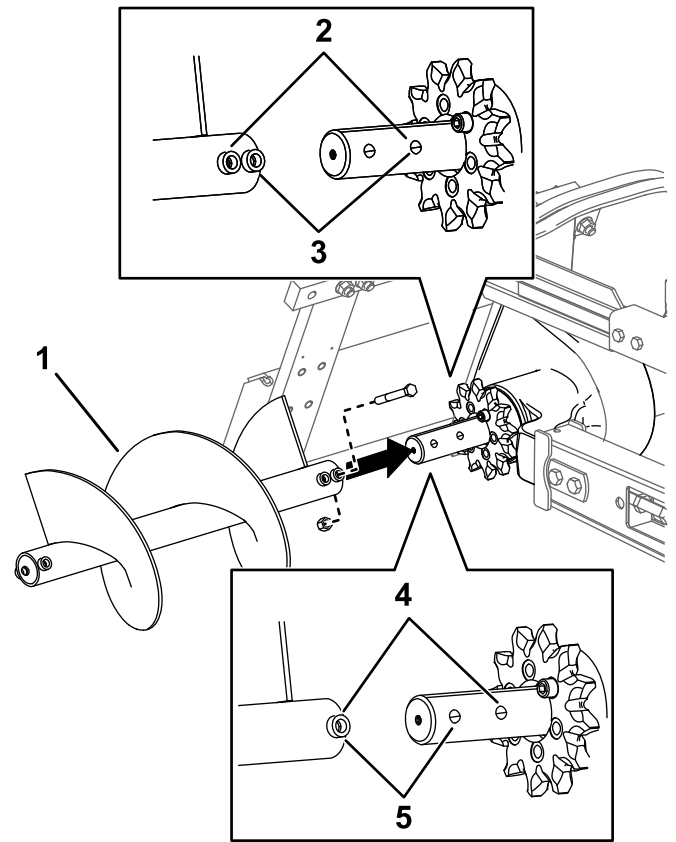

Figure 6

g414078

1. Auger
2. Connect these holes for a 10 cm (4 inch) chain.
3. Connect these holes for a 15 cm (6 inch) chain.
4. Connect these holes for a 20 cm (8 inch) chain.
5. Connect these holes for a 30 cm (12 inch) chain.

2. Torque the bolt and nut to 101 N·m (75 ft-lb).

# 4

## Checking the Bearing Case Lube Level

No Parts Required

### Procedure

Before operating the trencher, check to ensure that the bearing case is filled with gear lube; refer to [Checking the Bearing Case Lube Level \(page 14\)](#).



# Product Overview

## Specifications

**Note:** Specifications and design are subject to change without notice.

Width, with 91 cm (3 ft) boom	89 cm (35 inches)
Length, with 91 cm (3 ft) boom	165 cm (65 inches)
Height, with 91 cm (3 ft) boom	61 cm (24 inches)
Weight, with 91 cm (3 ft) boom	177 kg (390 lb)
Maximum trench depth, with 61 cm (2 ft) boom	61 cm (24 inches) at a 65 degree boom angle
Maximum trench depth, with 91 cm (3 ft) boom	91 cm (36 inches) at a 65 degree boom angle
Maximum trench depth, with 122 cm (4 ft) boom	122 cm (48 inches) at a 65 degree boom angle

To ensure optimum performance and continued safety certification of the machine, use only genuine Toro replacement parts and accessories. Replacement parts and accessories made by other manufacturers could be dangerous, and such use could void the product warranty.

# Operation

Determine the left and right sides of the machine from the normal operating position.

## Installing and Removing the Attachment

Refer to the *Operator's Manual* for the traction unit for the installation and removal procedure.

**Important:** Before installing the attachment, position the machine on a level surface, ensure that the mount plates are free of any dirt or debris, and ensure that the pins rotate freely. If the pins do not rotate freely, grease them.

**Note:** Always use the traction unit to lift and move the attachment.

### **⚠ WARNING**

If you do not fully seat the quick-attach pins through the attachment mount plate, the attachment could fall off the machine, crushing you or bystanders.

Ensure that the quick-attach pins are fully seated in the attachment mount plate.

### **⚠ WARNING**

Hydraulic fluid escaping under pressure can penetrate skin and cause injury. Fluid injected into the skin must be surgically removed within a few hours by a doctor familiar with this form of injury; otherwise, gangrene may result.

- Ensure that all hydraulic-fluid hoses and lines are in good condition and all hydraulic connections and fittings are tight before applying pressure to the hydraulic system.
- Keep your body and hands away from pinhole leaks or nozzles that eject high-pressure hydraulic fluid.
- Use cardboard or paper to find hydraulic leaks; never use your hands.

## ⚠ CAUTION

Hydraulic couplers, hydraulic lines/valves, and hydraulic fluid may be hot. If you contact hot components, you may be burned.

- Wear gloves when operating the hydraulic couplers.
- Allow the machine to cool before touching hydraulic components.
- Do not touch hydraulic fluid spills.

## Digging a Trench

1. If your traction unit has a speed selector, set it to the SLOW (turtle) position, then start the engine.
2. Pull the auxiliary hydraulics lever to the operator grip to engage the trencher.
3. Slowly lower the trencher to the ground so that the boom and chain are parallel to the ground.
4. Begin inserting the nose of the boom and chain into the ground by slowly raising the trencher a few centimeters (inches) off the ground while tilting the nose down into the ground gradually.
5. Once the trencher boom is in the ground at a 45 to 60 degree angle, slowly lower the trencher until the spoils auger is just above the ground.
6. Ensure that all parts of the trencher are functioning correctly.
7. Slowly move the traction unit rearward to extend the trench.

**Note:** If you move too fast, the trencher will stall. If it stalls, raise it slightly, slowly drive forward, or reverse the chain direction momentarily.

8. When finished, raise the trencher and boom out of the trench by tilting the attachment rearward, then stop the trencher by moving the auxiliary hydraulics lever into neutral.

## Offsetting the Trencher

You can move the trencher to the right side of the trencher frame to allow you to trench close to buildings and other obstacles.

1. Lower the trencher to the ground, engage the parking brake (if equipped), shut off the engine, and remove the key.
2. Disconnect the hydraulic lines from the trencher.

## ⚠ WARNING

Hydraulic fluid escaping under pressure can penetrate skin and cause injury. Fluid injected into the skin must be surgically removed within a few hours by a doctor familiar with this form of injury; otherwise, gangrene may result.

- Keep your body and hands away from pinhole leaks or nozzles that eject high-pressure hydraulic fluid.
- Use cardboard or paper to find hydraulic leaks; never use your hands.

3. Remove the 6 bolts securing the trencher head to the frame (Figure 7).

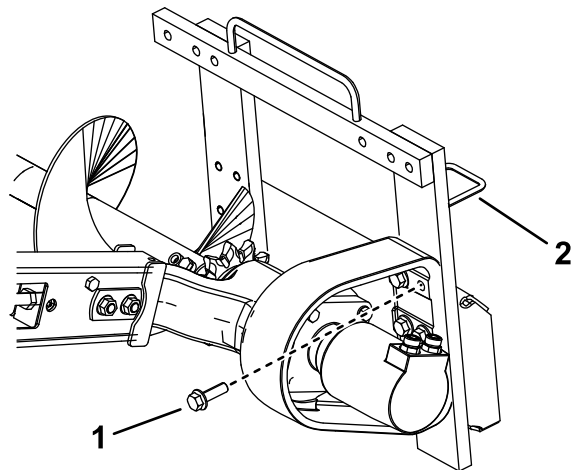
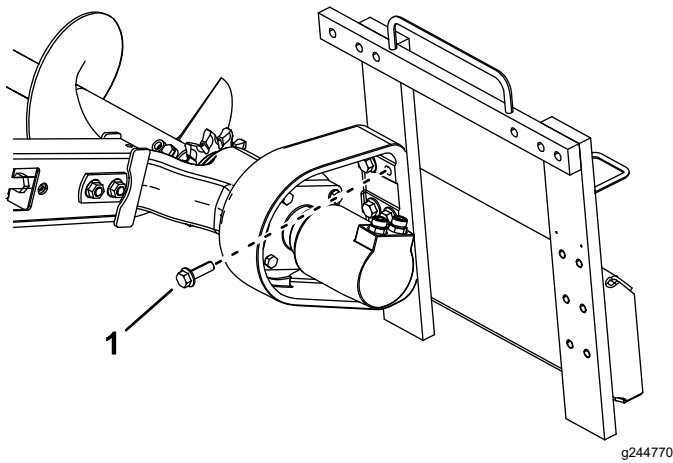

Figure 7

Safety bar not shown

1. Bolt (6)
2. Left hose guide

4. Move the frame to the left, aligning the holes in the right side of the frame with those in the head.
5. Attach the head to the frame with the 6 bolts removed previously (Figure 8).



**Figure 8**  
Safety bar not shown

1. Bolt (6)

- 
6. Torque the bolts to 257 to 311 N·m (190 to 230 ft-lb).
7. Remove the bolt (5/8 x 3 inches), 2 bolts (5/8 x 4 inches), 3 washers, and 3 nuts from the safety bar and remove the bar.
8. Remove the 2 bolts (5/8 x 3 inches), 2 washers, and 2 nuts securing the right side of the upper frame and move them to the corresponding holes on the left (Figure 9).

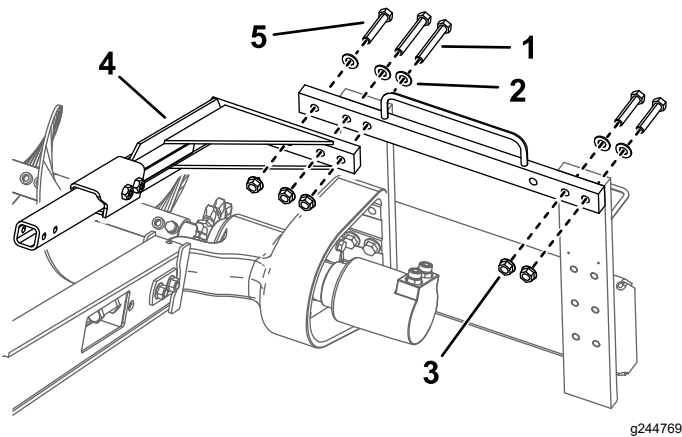

**Figure 9**

1. Bolt—5/8 x 4 inches (2)      4. Safety bar  
 2. Washer (5)                      5. Bolt—5/8 x 3 inches (3)  
 3. Nut (5)

- 
9. Install the safety bar over the trencher chain using the 3 bolts, washers, and flange nuts removed previously (Figure 9).
10. Torque all 5 bolts and nuts to 257 to 311 N·m (190 to 230 ft-lb).
11. Move the hoses from the hose guide on top of the trencher to the hose guide on the left side (Figure 7).

## Transport Position

When transporting the attachment, keep it as close to the ground as possible, no more than 15 cm (6 inches) above the ground. Tilt it rearward.

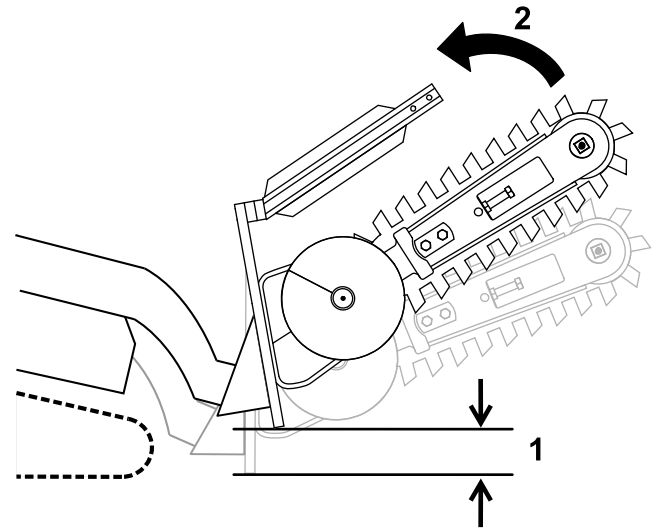

**Figure 10**

1. No more than 15 cm (6 inches) above the ground      2. Tilt the attachment rearward.

## Transporting the Trencher on a Trailer

Place the trencher on a trailer or truck capable of carrying it. Securely tie the trencher to the trailer or truck using tie straps appropriate for the weight of the trencher and for highway use.

# Operating Tips

- Clean the area of trash, branches, and rocks before trenching to prevent equipment damage.
- Always begin trenching with the slowest ground speed possible. Increase speed if conditions permit.
- Always use full throttle (maximum engine speed) when trenching.
- Always trench backward (i.e., in reverse).
- Never transport the trencher with the loader arms raised. Keep the arms lowered and the trencher tilted up.
- When trenching, the spoils auger should just clear the original ground surface to obtain maximum soil removal.
- Trench at a 45 to 60 degree angle for best results.
- To dig a trench faster, control the depth with periodic adjustments of the loader arms.
- If your traction unit has a speed selector, set it to the SLOW (turtle) position.
- If your traction unit has a flow divider (present on some wheeled traction units), adjust it to approximately the 10 o'clock position.
- If the trencher binds in the soil, push the auxiliary hydraulics lever fully forward to reverse the chain direction. Once the chain is loose, pull the lever rearward again and continue trenching.
- If you need the finished trench to be cleaner than what is possible with the trencher, you can purchase a crumber from your dealer. The crumber mounts onto the trencher and scrapes the trench clean as you run the trencher.
- To improve the quality of trenches less than 61 cm (24 inches) deep, use a 61 cm (24 inch) boom on the trencher.

# Maintenance

## Recommended Maintenance Schedule(s)

Maintenance Service Interval	Maintenance Procedure
Before each use or daily	<ul style="list-style-type: none"><li>• Grease the trencher.</li><li>• Inspect the boom for wear.</li></ul>
Every 25 hours	<ul style="list-style-type: none"><li>• Check the gear-lube level.</li><li>• Adjust the digging chain tension.</li><li>• Inspect the boom for wear.</li></ul>
Every 200 hours	<ul style="list-style-type: none"><li>• Change the gear lube.</li></ul>
Before storage	<ul style="list-style-type: none"><li>• Grease the trencher.</li><li>• Check the gear-lube level.</li></ul>

### **⚠ CAUTION**

If you leave the key in the switch, someone could accidentally start the engine and seriously injure you or other bystanders.

Remove the key from the switch before you perform any maintenance.

## Greasing the Trencher

Service Interval: Before each use or daily

Before storage

Grease 2 fittings, as shown in [Figure 11](#) and [Figure 12](#), every day and immediately after every washing.

Grease Type: General-purpose grease

1. Park the machine on a level surface, disengage the auxiliary hydraulics lever, lower the attachment, and engage the parking brake (if equipped).
2. Shut off the engine and remove the key
3. Clean the grease fittings with a rag.
4. Connect a grease gun to each fitting.
5. Pump grease into the fittings until grease begins to ooze out of the bearings.
6. Wipe up any excess grease.

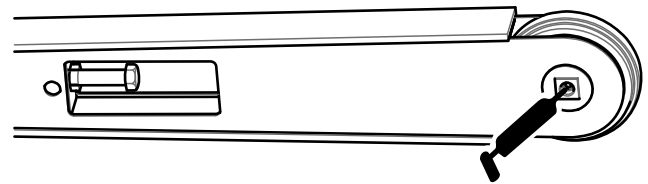

Figure 11

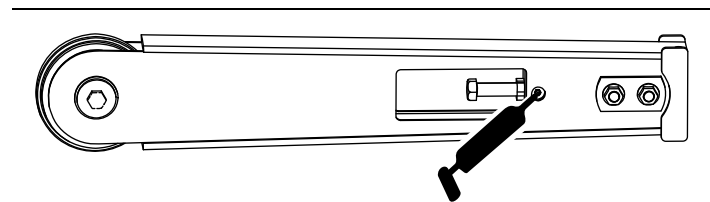

Figure 12

# Servicing the Bearing Case Lube

**Service Interval:** Every 25 hours—Check the gear-lube level.

Every 200 hours—Change the gear lube.

Before storage—Check the gear-lube level.

## Checking the Bearing Case Lube Level

Gear lube type: SAE 90-140 API service GL-4 or GL-5

Capacity: 0.5 L (17 fl oz)

1. Park the machine on a level surface, disengage the auxiliary hydraulics lever, lower the attachment, and engage the parking brake (if equipped).
2. Tilt the trencher so that the boom is parallel with the ground.
3. Shut off the engine and remove the key
4. Clean the area around the fill-hole plug on the bearing case (Figure 13).

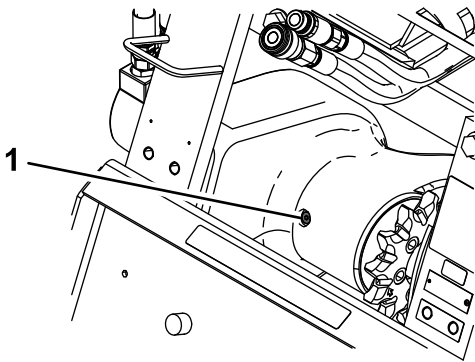

**Figure 13**

g244664

1. Fill-hole plug on the bearing case
5. Remove the plug from the fill hole (Figure 13).
6. Look in the hole and check the level of gear lube in the bearing case.  
**Note:** The level should be up to the bottom of the hole; if it is not, add gear lube.
7. Replace the plug and torque it to 20 to 23 N·m (15 to 17 ft-lb).

## Changing the Gear Lube

1. Park the machine on a level surface, disengage the auxiliary hydraulics lever, lower the attachment, and engage the parking brake (if equipped).
2. Shut off the engine and remove the key
3. Clean the area around the fill-hole plug on the bearing case (Figure 13).
4. Remove the plug from the fill hole (Figure 13).
5. Lift the trencher until the boom is vertical, draining the lube through the fill hole and into a pan.
6. Return the trencher to the ground.
7. Fill the bearing case with gear lube until it comes out of the fill hole.
8. Replace the plug and torque it to 20 to 23 N·m (15 to 17 ft-lb).

## Adjusting the Digging Chain Tension

**Service Interval:** Every 25 hours—Adjust the digging chain tension.

With the trencher parallel to the ground, ensure that there is 3.8 to 6.3 cm (1-1/2 to 2-1/2 inches) between the bottom of the boom and the top of the bottom chain span. If not, adjust the chain using the following procedure:

**Important:** Do not overtighten the chain. Excess chain tension may damage drive components.

1. Park the machine on a level surface, disengage the auxiliary hydraulics lever, lower the attachment, and tilt it so that the boom is parallel with the ground. Engage the parking brake (if equipped).
2. Shut off the engine and remove the key
3. Loosen the 2 bolts and nuts securing the boom to the trencher arm (Figure 3).
4. Loosen the jam nut securing the adjustment bolt (Figure 3).
5. Turn the adjustment bolt in or out as needed to achieve the desired tension.
6. Tighten the jam nut.
7. Torque the 2 bolts and nuts securing the boom to 183 to 223 N·m (135 to 165 ft-lb).

# Flipping a Worn Boom

**Service Interval:** Every 25 hours—Inspect the boom for wear.

Inspect the bottom of the boom for wear, if it is worn, complete the following:

**Note:** If you have already flipped the boom once, replace the boom when both sides are worn.

1. Park the machine on a level surface, disengage the auxiliary hydraulics lever, lower the attachment, and engage the parking brake (if equipped).
2. Shut off the engine and remove the key
3. Remove the 2 bolts and nuts securing the boom to the trencher arm (Figure 3).
4. Loosen the jam nut on the adjusting bolt in the boom (Figure 3).
5. Loosen the adjusting bolt until you can remove the chain from the boom (Figure 3).
6. Remove the chain from the drive sprocket and boom.
7. Remove the boom, flip it over so the bottom becomes the top (or if you have already flipped it once, replace it), and install the boom again.
8. Replace the nuts, bolts, and washers securing the boom.
9. Install the chain over the drive sprocket and front roller.
10. Adjust the chain tension; refer to [Adjusting the Digging Chain Tension](#) (page 14).

# Replacing the Digging Teeth

**Service Interval:** Before each use or daily—Inspect the boom for wear.

Due to the high amount of wear placed on the digging teeth, you need to replace them periodically.

To replace a single tooth, remove the bolts and nuts securing the tooth to remove it, then install a new tooth in the same position. Torque the bolts securing the teeth to 37 to 45 N·m (27 to 33 ft-lb).

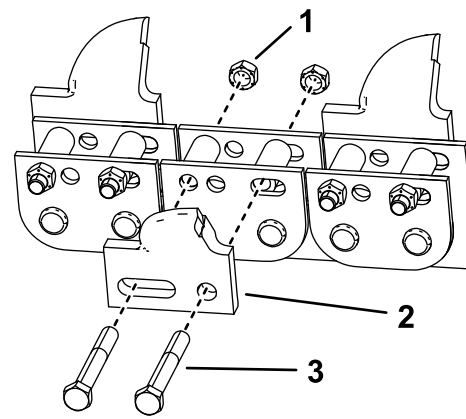

Figure 14

1. Nut
2. Tooth
3. Nut

g245068

# Replacing the Drive Sprocket

Over time, the drive sprocket will wear, especially when used in sandy or clay soils. When this happens, the digging chain will begin to slip. If the chain slips, replace the drive sprocket as follows:

1. Park the machine on a level surface, disengage the auxiliary hydraulics lever, lower the attachment, and engage the parking brake (if equipped).
2. Raise the trencher a few centimeters (inches) above the ground.
3. Shut off the engine and remove the key
4. Remove the spoils auger (Figure 15).

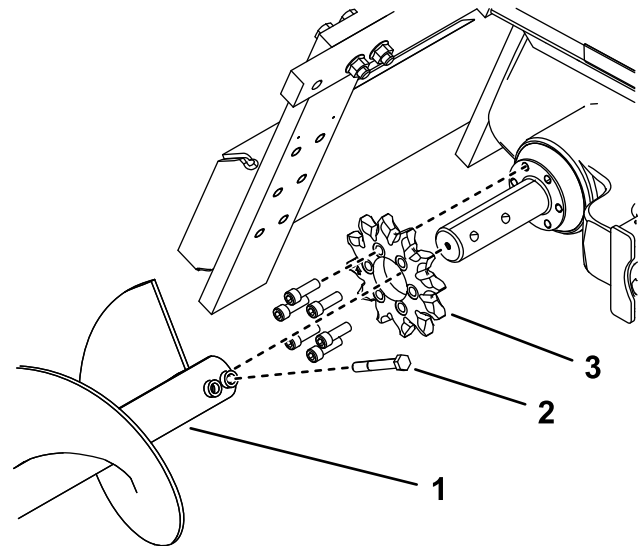

Figure 15

1. Spoils auger
2. Drive sprocket
3. Bolts

g244973

# Storage

5. Loosen the 2 bolts and nuts securing the boom to the trencher arm ([Figure 3](#)).
6. Loosen the jam nut on the adjusting bolt in the boom ([Figure 3](#)).
7. Loosen the adjusting bolt until you can remove the chain from the boom ([Figure 3](#)).
8. Remove the chain from the drive sprocket.
9. Remove the 6 bolts securing the drive sprocket ([Figure 15](#)).
10. Remove and discard the drive sprocket ([Figure 15](#)).
11. Clean the sprocket mounting surface on the trencher.
12. Slide the new sprocket onto the shaft as illustrated in ([Figure 15](#)).

**Important:** The arrow on the sprocket face should be visible from the right side of the trencher and should point in a clockwise direction; if not, turn the sprocket around.

13. Thread the 6 bolts into the sprocket finger tight ([Figure 15](#)).
14. Slowly begin tightening the bolts progressing around the sprocket until all bolts are torqued to 129 to 155 N·m (95 to 115 ft-lb).

**Important:** Tighten each bolt only half way first, working your way around the 6 bolts, then return to each bolt in turn and torque them to the specifications given in step 13.

15. Loop the chain over the auger drive shaft and onto the drive sprocket, ensuring that the teeth point forward on the upper span.
16. Set the upper span of the chain into place on the trencher boom, then wrap the chain around the roller at the end of the boom.
17. Thread the adjustment bolt into the boom and turn it in until there is 3.8 to 6.3 cm (1-1/2 to 2-1/2 inches) of slack in the chain on the bottom span.
18. Thread the jam nut down the adjusting bolt and tighten it securely against the boom.
19. Torque the 2 bolts and nuts securing the boom to 183 to 223 N·m (135 to 165 ft-lb).
20. Install the spoils auger; refer to [3 Installing the Spoils Auger \(page 7\)](#).

1. Before long term storage, brush the dirt from the attachment.
2. Check the condition of the digging chain. Adjust the digging chain tension; refer to [Adjusting the Digging Chain Tension \(page 14\)](#). Replace any worn or damaged teeth; refer to [Replacing the Digging Teeth \(page 15\)](#).
3. Grease the trencher; refer to [Greasing the Trencher \(page 13\)](#).
4. Check bearing case lube level; refer to [Checking the Bearing Case Lube Level \(page 14\)](#).
5. Check and tighten all bolts, nuts, and screws. Repair or replace any part that is damaged or worn.
6. Ensure that all hydraulic couplers are connected together to prevent contamination of the hydraulic system.
7. Paint all scratched or bare metal surfaces. Paint is available from your Authorized Service Dealer.
8. Store the trencher in a clean, dry garage or storage area. Cover the trencher to protect it and keep it clean.



# Declaration of Incorporation

The Toro Company, 8111 Lyndale Avenue South, Bloomington, MN, USA declares that the following unit(s) conform(s) to the directives listed, when installed in accordance with the accompanying instructions onto certain Toro models as indicated on the relevant Declarations of Conformity.

Model No.	Serial No.	Product Description	Invoice Description	General Description	Directive
22473	404310000 and Up	High-Torque Trencher Head	HIGH TORQUE TRENCHER HEAD	Trencher	2006/42/EC
22474	404200000 and Up	High-Speed Trencher Head	HIGH SPEED TRENCHER HEAD	Trencher	2006/42/EC

Relevant technical documentation has been compiled as required per Part B of Annex VII of 2006/42/EC.

We will undertake to transmit, in response to requests by national authorities, relevant information on this partly completed machinery. The method of transmission shall be electronic transmittal.

This machinery shall not be put into service until incorporated into approved Toro models as indicated on the associated Declaration of Conformity and in accordance with all instructions, whereby it can be declared in conformity with all relevant Directives.

Certified:



Chad Moe  
Sr. Engineering Manager  
8111 Lyndale Ave. South  
Bloomington, MN 55420, USA  
October 19, 2022

Authorized Representative:

Marcel Dutrieux  
Manager European Product Integrity  
Toro Europe NV  
Nijverheidsstraat 5  
2260 Oevel  
Belgium

# UK Declaration of Incorporation

The Toro Company, 8111 Lyndale Avenue South, Bloomington, MN, USA declares that the following unit(s) conform(s) to the directives listed, when installed in accordance with the accompanying instructions onto certain Toro models as indicated on the relevant Declarations of Conformity.

Model No.	Serial No.	Product Description	Invoice Description	General Description	Regulation
22473	404310000 and Up	High-Torque Trencher Head	HIGH TORQUE TRENCHER HEAD	Trencher	S.I. 2008 No. 1597
22474	404200000 and Up	High-Speed Trencher Head	HIGH SPEED TRENCHER HEAD	Trencher	S.I. 2008 No. 1597

Relevant technical documentation has been compiled as required per Schedule 10 of S.I. 2008 No. 1597.

We will undertake to transmit, in response to requests by national authorities, relevant information on this partly completed machinery. The method of transmission shall be electronic transmittal.

This machinery shall not be put into service until incorporated into approved Toro models as indicated on the associated Declaration of Conformity and in accordance with all instructions, whereby it can be declared in conformity with all relevant Directives.

This declaration has been issued under the sole responsibility of the manufacturer.

The object of the declaration is in conformity with relevant UK legislation.

Authorized Representative:

Marcel Dutrieux  
Manager European Product Integrity  
Toro U.K. Limited  
Spellbrook Lane West  
Bishop's Stortford  
CM23 4BU  
United Kingdom



Chad Moe  
Sr. Engineering Manager  
8111 Lyndale Ave. South  
Bloomington, MN 55420, USA  
October 19, 2022

## **European Privacy Notice**

### **The Information Toro Collects**

Toro Warranty Company (Toro) respects your privacy. In order to process your warranty claim and contact you in the event of a product recall, we ask you to share certain personal information with us, either directly or through your local Toro company or dealer.

The Toro warranty system is hosted on servers located within the United States where privacy law may not provide the same protection as applies in your country.

**BY SHARING YOUR PERSONAL INFORMATION WITH US, YOU ARE CONSENTING TO THE PROCESSING OF YOUR PERSONAL INFORMATION AS DESCRIBED IN THIS PRIVACY NOTICE.**

### **The Way Toro Uses Information**

Toro may use your personal information to process warranty claims, to contact you in the event of a product recall and for any other purpose which we tell you about. Toro may share your information with Toro's affiliates, dealers or other business partners in connection with any of these activities. We will not sell your personal information to any other company. We reserve the right to disclose personal information in order to comply with applicable laws and with requests by the appropriate authorities, to operate our systems properly or for our own protection or that of other users.

### **Retention of your Personal Information**

We will keep your personal information as long as we need it for the purposes for which it was originally collected or for other legitimate purposes (such as regulatory compliance), or as required by applicable law.

### **Toro's Commitment to Security of Your Personal Information**

We take reasonable precautions in order to protect the security of your personal information. We also take steps to maintain the accuracy and current status of personal information.

### **Access and Correction of your Personal Information**

If you would like to review or correct your personal information, please contact us by email at [legal@toro.com](mailto:legal@toro.com).

## **Australian Consumer Law**

Australian customers will find details relating to the Australian Consumer Law either inside the box or at your local Toro Dealer.

# California Proposition 65 Warning Information

## What is this warning?

You may see a product for sale that has a warning label like the following:



**WARNING: Cancer and Reproductive Harm—[www.p65Warnings.ca.gov](http://www.p65Warnings.ca.gov).**

## What is Prop 65?

Prop 65 applies to any company operating in California, selling products in California, or manufacturing products that may be sold in or brought into California. It mandates that the Governor of California maintain and publish a list of chemicals known to cause cancer, birth defects, and/or other reproductive harm. The list, which is updated annually, includes hundreds of chemicals found in many everyday items. The purpose of Prop 65 is to inform the public about exposure to these chemicals.

Prop 65 does not ban the sale of products containing these chemicals but instead requires warnings on any product, product packaging, or literature with the product. Moreover, a Prop 65 warning does not mean that a product is in violation of any product safety standards or requirements. In fact, the California government has clarified that a Prop 65 warning "is not the same as a regulatory decision that a product is 'safe' or 'unsafe.'" Many of these chemicals have been used in everyday products for years without documented harm. For more information, go to <https://oag.ca.gov/prop65/faqs-view-all>.

A Prop 65 warning means that a company has either (1) evaluated the exposure and has concluded that it exceeds the "no significant risk level"; or (2) has chosen to provide a warning based on its understanding about the presence of a listed chemical without attempting to evaluate the exposure.

## Does this law apply everywhere?

Prop 65 warnings are required under California law only. These warnings are seen throughout California in a wide range of settings, including but not limited to restaurants, grocery stores, hotels, schools, and hospitals, and on a wide variety of products. Additionally, some online and mail order retailers provide Prop 65 warnings on their websites or in catalogs.

## How do the California warnings compare to federal limits?

Prop 65 standards are often more stringent than federal and international standards. There are various substances that require a Prop 65 warning at levels that are far lower than federal action limits. For example, the Prop 65 standard for warnings for lead is 0.5 µg/day, which is well below the federal and international standards.

## Why don't all similar products carry the warning?

- Products sold in California require Prop 65 labelling while similar products sold elsewhere do not.
- A company involved in a Prop 65 lawsuit reaching a settlement may be required to use Prop 65 warnings for its products, but other companies making similar products may have no such requirement.
- The enforcement of Prop 65 is inconsistent.
- Companies may elect not to provide warnings because they conclude that they are not required to do so under Prop 65; a lack of warnings for a product does not mean that the product is free of listed chemicals at similar levels.

## Why does Toro include this warning?

Toro has chosen to provide consumers with as much information as possible so that they can make informed decisions about the products they buy and use. Toro provides warnings in certain cases based on its knowledge of the presence of one or more listed chemicals without evaluating the level of exposure, as not all the listed chemicals provide exposure limit requirements. While the exposure from Toro products may be negligible or well within the "no significant risk" range, out of an abundance of caution, Toro has elected to provide the Prop 65 warnings. Moreover, if Toro does not provide these warnings, it could be sued by the State of California or by private parties seeking to enforce Prop 65 and subject to substantial penalties.