



**Count on it.**

**Operator's Manual**

# Bore Drive Head Attachment Compact Tool Carrier

Model No. 22420—Serial No. 404320000 and Up

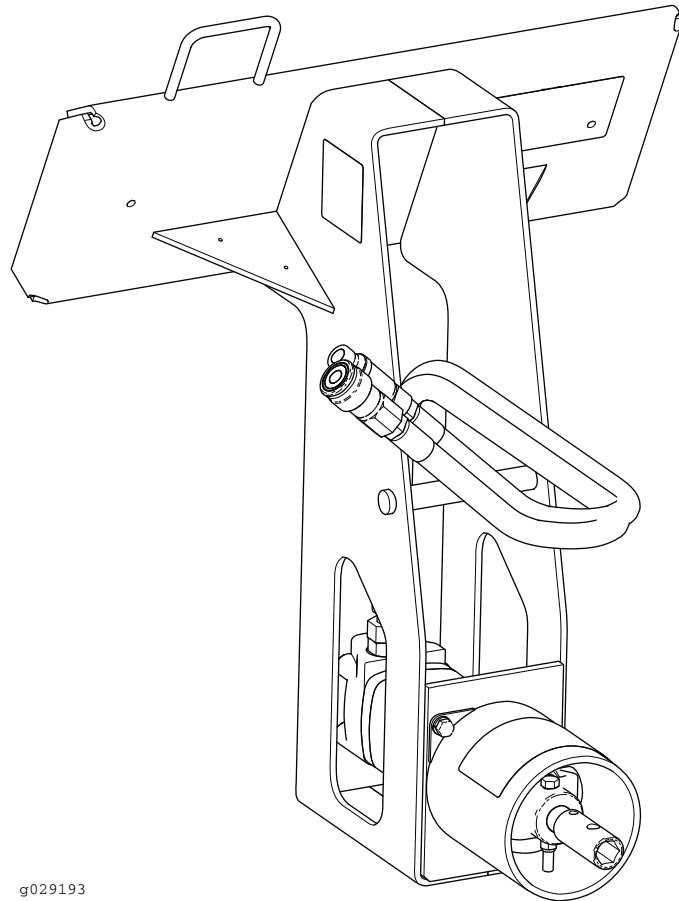

g029193



This product complies with all relevant European directives. For details, please see the Declaration of Incorporation (DOI) at the back of this publication.

**⚠ WARNING**

**CALIFORNIA  
Proposition 65 Warning**

**Use of this product may cause exposure to chemicals known to the State of California to cause cancer, birth defects, or other reproductive harm.**

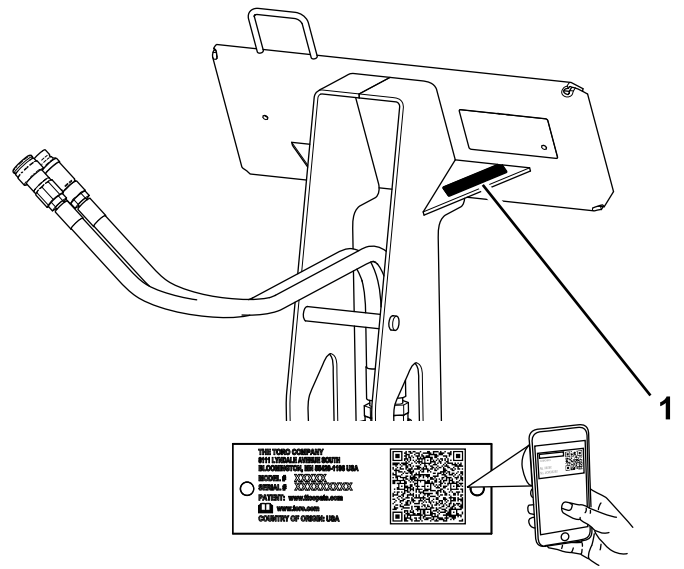

**Figure 1**

g257161

1. Model and serial number location

Model No. \_\_\_\_\_

Serial No. \_\_\_\_\_

## Introduction

The machine is a hydraulically powered auger attachment for Toro compact tool carriers. It is designed to bore holes under paved surfaces and pull either wires or piping back through the hole under the pavement. It is intended for boring through soil and gravel. It is not designed to bore through rock, wood, or other hard materials. Using this product for purposes other than its intended use could prove dangerous to you and bystanders.

Read this information carefully to learn how to operate and maintain your product properly and to avoid injury and product damage. You are responsible for operating the product properly and safely.

Visit [www.Toro.com](http://www.Toro.com) for product safety and operation training materials, accessory information, help finding a dealer, or to register your product.

Whenever you need service, genuine Toro parts, or additional information, contact an Authorized Service Dealer or Toro Customer Service and have the model and serial numbers of your product ready. [Figure 1](#) identifies the location of the model and serial numbers on the product. Write the numbers in the space provided.

**Important:** With your mobile device, you can scan the QR code on the serial number decal (if equipped) to access warranty, parts, and other product information.

This manual identifies potential hazards and has safety messages identified by the safety-alert symbol ([Figure 2](#)), which signals a hazard that may cause serious injury or death if you do not follow the recommended precautions.



**Figure 2**

g000502

1. Safety-alert symbol

This manual uses 2 words to highlight information. **Important** calls attention to special mechanical information and **Note** emphasizes general information worthy of special attention.

# Contents

Safety .....	3
General Safety .....	3
Slope Safety .....	4
Boring Unit Safety .....	4
Maintenance and Storage Safety .....	4
Safety and Instructional Decals .....	5
Product Overview .....	5
Specifications .....	5
Operation .....	6
Installing and Removing the Attachment .....	6
Installing an Accessory .....	6
Removing an Accessory .....	7
Using the Boring Unit .....	7
Transport Position .....	8
Storage .....	9
Troubleshooting .....	10

# Safety

## **⚠ DANGER**

**There may be buried utility lines in the work area. Digging into them may cause a shock or an explosion.**

**Have the property or work area marked for buried lines and do not dig in marked areas. Contact your local marking service or utility company to have the property marked (for example, in the US, call 811 or in Australia, call 1100 for the nationwide marking service).**

## General Safety

Always follow all safety instructions to avoid serious injury or death.

- Do not exceed the rated operating capacity, as the machine may become unstable, which may result in loss of control.
- Always transport the attachment close to the ground; refer to [Transport Position \(page 8\)](#).
- Have the property or work area marked for buried lines and other objects, and do not dig in marked areas.
- Read and understand the content of this *Operator's Manual* before starting the machine.
- Use your full attention while operating the machine. Do not engage in any activity that causes distractions; otherwise, injury or property damage may occur.
- Never allow children or untrained people to operate the machine.
- Keep your hands and feet away from the moving components and attachments.
- Do not operate the machine without the guards and other safety protective devices in place and working on the machine.
- Keep bystanders and pets away from the machine.
- Stop the machine, shut off the machine, and remove the key before servicing, fueling, or unclogging the machine.

Improperly using or maintaining this machine can result in injury. To reduce the potential for injury, comply with these safety instructions and always pay attention to the safety-alert symbol **⚠**, which means Caution, Warning, or Danger—personal safety instruction. Failure to comply with these instructions may result in personal injury or death.

## Slope Safety

- **Operate the machine up and down slopes with the heavy end of the machine uphill.** Weight distribution changes with attachments. This attachment makes the rear of machine the heavy end.
- Raising the loader arms on a slope affects the stability of the machine. Keep the loader arms in the lowered position when on slopes.
- Slopes are a major factor related to loss of control and tip-over accidents, which can result in severe injury or death. Operating the machine on any slope or uneven terrain requires extra caution.
- Establish your own procedures and rules for operating on slopes. These procedures must include surveying the site to determine which slopes are safe for machine operation. Always use common sense and good judgment when performing this survey.
- Slow down and use extra care on hillsides. Ground conditions can affect the stability of the machine.
- Avoid starting or stopping on a slope. If the machine loses traction, proceed slowly, straight down the slope.
- Avoid turning on slopes. If you must turn, turn slowly and keep the heavy end of the machine uphill.
- Keep all movements on slopes slow and gradual. Do not make sudden changes in speed or direction.
- If you feel uneasy operating the machine on a slope, do not do it.
- Watch for holes, ruts, or bumps, as uneven terrain could overturn the machine. Tall grass can hide obstacles.
- Use caution when operating on wet surfaces. Reduced traction could cause sliding.
- Evaluate the area to ensure that the ground is stable enough to support the machine.
- Use caution when operating the machine near the following:
  - Drop-offs
  - Ditches
  - Embankments
  - Bodies of water

The machine could suddenly roll over if a track goes over the edge or the edge caves in. Maintain a safe distance between the machine and any hazard.

- Do not remove or add attachments on a slope.
- Do not park the machine on a hillside or slope.

## Boring Unit Safety

- For wheeled machines, do not use the counterweight on the traction unit when using the boring unit.
- Keep at least 3 m (10 ft) from rotating parts, unless you are operating the rod guide tool.
- Do not wear loose clothing or jewelry while operating or assisting with the boring unit.
- Never use anything but the rod guide tool for starting the rod and boring bit.
- Never use bolts or pins in place of push button connectors.
- Always have 2 people operate the attachment, 1 to operate the traction unit and the other to guide the boring unit with the guide tool.
- Always use the guide tool to align the boring unit.
- Never straddle or stand on the rod when the engine is running.

## Maintenance and Storage Safety

- Check fasteners at frequent intervals for proper tightness to ensure that the equipment is in safe operating condition.
- Refer to this *Operator's Manual* for important details if you store the attachment for an extended period of time.
- Maintain or replace safety and instruction labels, as necessary.

# Safety and Instructional Decals



Safety decals and instructions are easily visible to the operator and are located near any area of potential danger. Replace any decal that is damaged or missing.

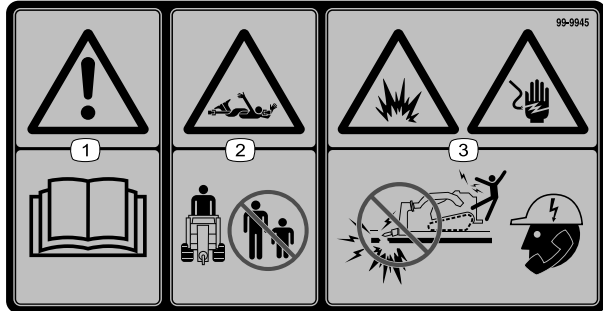

99-9945

decal99-9945

1. Warning—read the *Operator's Manual*.
2. Entanglement hazard, shaft—keep bystanders away.
3. Explosion hazard; electric shock hazard—do not operate if power lines may be present; call your local utility company.

**⚠ WARNING:** Cancer and Reproductive Harm - [www.P65Warnings.ca.gov](http://www.P65Warnings.ca.gov).  
For more information, please visit [www.ttcocaprop65.com](http://www.ttcocaprop65.com)

133-8061

133-8061

decal133-8061

# Product Overview

## Specifications

**Note:** Specifications and design are subject to change without notice.

Width	61 cm (24 inches)
Length	56 cm (22 inches)
Height	63.5 cm (25 inches)
Weight	54 kg (120 lb)
Boring diameter	3.2 to 8.9 cm (1.25 to 3.5 inches)

To ensure optimum performance and continued safety certification of the machine, use only genuine Toro replacement parts and accessories. Replacement parts and accessories made by other manufacturers could be dangerous, and such use could void the product warranty.

# Operation

## Installing and Removing the Attachment

Refer to the *Operator's Manual* for the traction unit for the installation and removal procedure.

**Important:** Before installing the attachment, position the machine on a level surface, ensure that the mount plates are free of any dirt or debris, and ensure that the pins rotate freely. If the pins do not rotate freely, grease them.

**Note:** Always use the traction unit to lift and move the attachment.

### ⚠ WARNING

If you do not fully seat the quick-attach pins through the attachment mount plate, the attachment could fall off the machine, crushing you or bystanders.

Ensure that the quick-attach pins are fully seated in the attachment mount plate.

### ⚠ WARNING

Hydraulic fluid escaping under pressure can penetrate skin and cause injury. Fluid injected into the skin must be surgically removed within a few hours by a doctor familiar with this form of injury; otherwise, gangrene may result.

- Ensure that all hydraulic-fluid hoses and lines are in good condition and all hydraulic connections and fittings are tight before applying pressure to the hydraulic system.
- Keep your body and hands away from pinhole leaks or nozzles that eject high-pressure hydraulic fluid.
- Use cardboard or paper to find hydraulic leaks; never use your hands.

### ⚠ CAUTION

Hydraulic couplers, hydraulic lines/valves, and hydraulic fluid may be hot. If you contact hot components, you may be burned.

- Wear gloves when disconnecting the hydraulic couplers.
- Allow the machine to cool before touching hydraulic components.
- Do not touch hydraulic fluid spills.

## Installing an Accessory

Several different rods and bits are available for use with the attachment. Contact your Authorized Service Dealer.

1. Park the machine on a level surface, lower the loader arms, and engage the parking brake (if applicable).
2. Shut off the engine, remove the key, and wait for all moving parts to stop.
3. Slide the hex shaft of a rod, boring bit, or reamer into the socket. Align the hole in the socket with the push button connector (Figure 3).

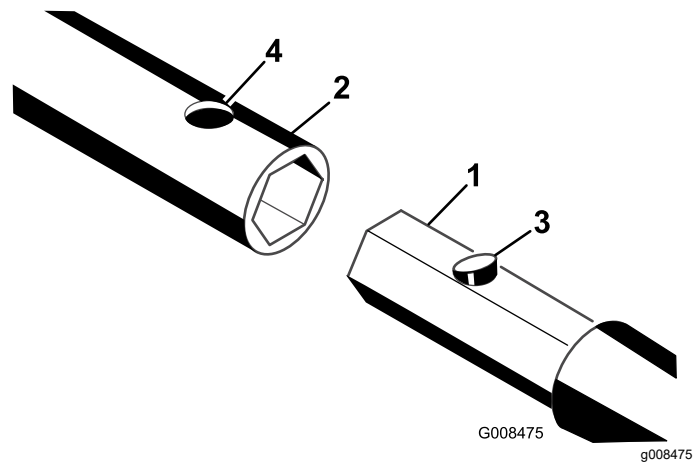

Figure 3

- |                    |                          |
|--------------------|--------------------------|
| 1. Accessory shaft | 3. Push button connector |
| 2. Socket          | 4. Hole                  |

4. Press down the push button connector and push the shaft into the socket until the connector snaps into the hole in the socket (Figure 3).
5. Repeat steps 3 and 4.

# Removing an Accessory

1. Park the machine on a level surface, lower the loader arms, and engage the parking brake (if applicable).
2. Shut off the engine, remove the key, and wait for all moving parts to stop.
3. Press the push button connector securing the accessory shaft in the socket and pull the accessory free of the socket.

# Using the Boring Unit

## Digging a Trench

Before drilling under a walk or driveway, you must make an entrance and an exit trench on either side of the drilling area (Figure 4).

- Both trenches must be at least 15 cm (6 inch) wide and 46 cm (18 inches) deep.
- The entrance trench must be at least 2.13 m (7 ft) long and perpendicular to the walk or driveway.
- The exit trench must be at least 0.91 m (3 ft) to 1.8 m (6 ft) long, parallel to the walk or driveway, and centered across from the entrance trench.

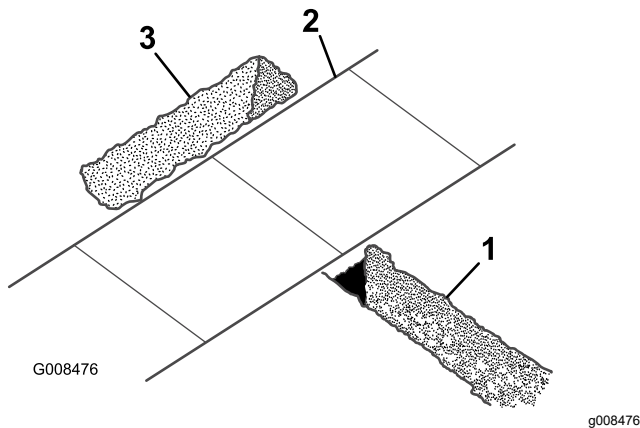

Figure 4

1. Entrance trench
2. Sidewalk
3. Exit trench

# Boring a Hole

**Important:** Boring is a 2-person operation. Do not attempt to perform this operation by yourself.

1. Position the traction unit with the drive head at the beginning of the trench and lower it to the appropriate depth.
2. Shut off the engine, remove the key, and wait for all moving parts to stop.
3. Connect a rod and boring bit onto the drive head.
4. Connect the rod guide tool to the rod just behind the boring bit (Figure 5).

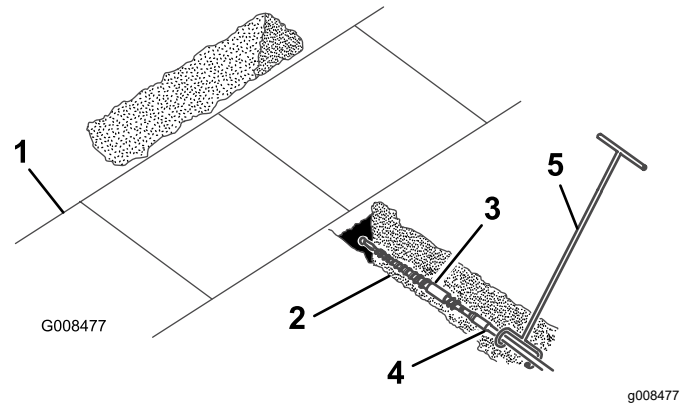

Figure 5

1. Sidewalk or driveway
2. Entrance trench
3. Boring unit
4. Rod
5. Rod-guide tool

5. With the person guiding the boring bit positioned to the right of the trench (Figure 5), start the engine, move the pump selector valve to the SLOW position (200 and 300 Series traction units only), move the throttle to midway between the SLOW and FAST positions, and pull the auxiliary hydraulics lever rearward to start the forward rotation of the boring bit.
6. Slowly move the traction unit forward, while the person with the rod-guide tool guides the boring bit into the soil (Figure 5).
7. Once the entire drill bit is in the soil, push the auxiliary hydraulics lever into neutral.
8. Shut off the engine, remove the key, and wait for all moving parts to stop.
9. If the rod is not within the grade tolerances for the job being performed, start the engine and drive backward to pull the boring bit out of the soil, then repeat steps 5 through 8, making adjustments to correct the grade.
10. Remove the rod-guide tool.
11. Start the engine and pull the auxiliary hydraulics lever rearward to start the boring bit.

12. Slowly move the traction unit forward as the boring bit digs into the soil.  
**Important: Do not drive too fast, forcing the bit into the soil. Allow the bit to progress at its own rate. Never push or pull the bit through the soil when the drive head is not turning.**
13. When about 15 cm (6 inches) of rod are left showing in the entrance trench or when the boring bit completely enters and bores into the far side of the exit trench, stop the traction unit, push the auxiliary hydraulics lever into neutral, shut off the engine, and remove the key.
14. If the boring bit has not yet entered the exit trench, complete the following:
  - A. Detach the rod from the drive head.
  - B. Start the engine and back up to the end of the entrance trench.
  - C. Shut off the engine, remove the key, and wait for all moving parts to stop.
  - D. Connect another rod and repeat steps 11 through 14.

## Reaming the Hole

1. Using a shovel, carefully dig around the boring bit, clearing it of soil until you can remove the bit (Figure 6).

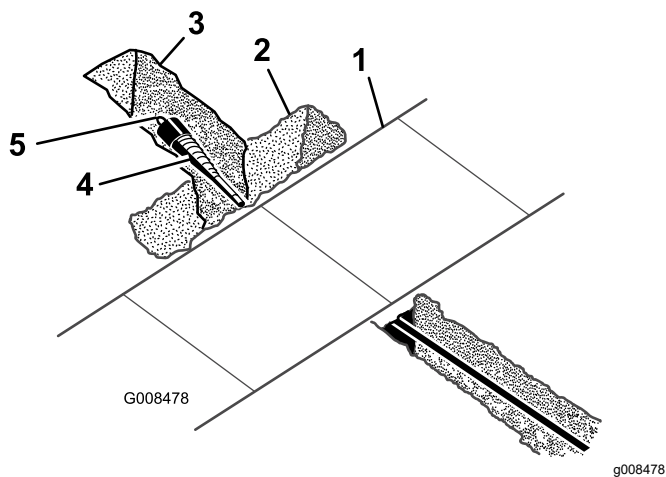

Figure 6

- |                                   |           |
|-----------------------------------|-----------|
| 1. Sidewalk or driveway           | 4. Reamer |
| 2. Exit trench                    | 5. Swivel |
| 3. Shovel dug-out area around bit |           |

2. Remove the boring bit and attach the reamer (Figure 6).
3. Attach the cable or piping being installed to the swivel on the end of the reamer (Figure 6).
4. Start the engine and pull the auxiliary hydraulics lever rearward to start the reamer.

5. Slowly move the traction unit rearward as the reamer digs into the soil.  
**Important: Do not drive too fast, forcing the reamer into the soil. Allow the reamer to progress at its own rate. Never push or pull the reamer through the soil when the drive head is not turning.**
6. When a rod coupling is about 15 cm (6 inches) into the entrance trench or when the reamer completely enters the trench with about 15 cm (6 inches) of the cable or piping, stop the traction unit, pull the auxiliary hydraulics lever into neutral, shut off the engine, and remove the key.
7. If the reamer has not yet entered the exit trench, complete the following:
  - A. Detach the rod from the drive head and rod still in the soil.
  - B. Start the engine and move to the front of the entrance trench.
  - C. Shut off the engine, remove the key, and wait for all moving parts to stop.
  - D. Connect the drive head to the rod shaft in the soil.
  - E. Repeat steps 4 through 7.
8. With the reamer and cable/piping in the entrance trench, remove the cable or piping from the reamer.

## Transport Position

When transporting the attachment, raise the loader arms slightly, no more than 15 cm (6 inches) above the ground. Tilt the attachment so that the attachment plate is vertical.

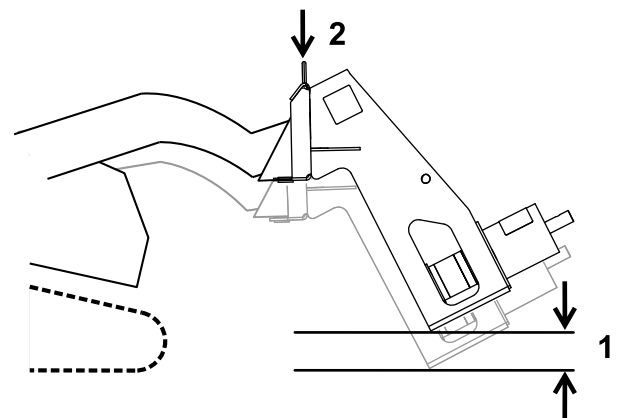

Figure 7

1. No more than 15 cm (6 inches) above the ground
2. Attachment plate is vertical.



# Storage

1. Before long-term storage, wash the attachment with mild detergent and water to remove dirt and grime.
2. Check the condition of the teeth. Turn or replace any worn or damaged teeth.
3. Check and tighten all hardware. Repair or replace any damaged or worn part.
4. Ensure that all hydraulic couplers are connected together to prevent contamination of the hydraulic system.
5. Paint all scratched or bare metal surfaces. Paint is available from your Authorized Service Dealer.
6. Store the attachment in a clean, dry garage or storage area. Cover it to protect it and keep it clean.

# Troubleshooting

Problem	Possible Cause	Corrective Action
The bore drive head does not rotate.	<ol style="list-style-type: none"><li>1. The hydraulic coupler is not completely connected.</li><li>2. A hydraulic coupler is damaged.</li><li>3. There is an obstruction in a hydraulic hose.</li><li>4. A hydraulic hose is kinked.</li><li>5. The auxiliary valve on the traction unit is not opening.</li><li>6. A hydraulic motor is damaged or worn.</li></ol>	<ol style="list-style-type: none"><li>1. Check and tighten all couplers.</li><li>2. Check the couplers and replace any that are damaged.</li><li>3. Find and remove the obstruction.</li><li>4. Replace the kinked hose.</li><li>5. Repair the valve.</li><li>6. Replace or repair the motor.</li></ol>

**Notes:**

# Declaration of Incorporation

The Toro Company, 8111 Lyndale Avenue South, Bloomington, MN, USA declares that the following unit(s) conform(s) to the directives listed, when installed in accordance with the accompanying instructions onto certain Toro models as indicated on the relevant Declarations of Conformity.

Model No.	Serial No.	Product Description	Invoice Description	General Description	Directive
22420	404320000 and Up	Bore Drive Head Attachment	BORE DRIVE HEAD ATTACHMENT CE	Compact Utility Loader	2006/42/EC

Relevant technical documentation has been compiled as required per Part B of Annex VII of 2006/42/EC.

We will undertake to transmit, in response to requests by national authorities, relevant information on this partly completed machinery. The method of transmission shall be electronic transmittal.

This machinery shall not be put into service until incorporated into approved Toro models as indicated on the associated Declaration of Conformity and in accordance with all instructions, whereby it can be declared in conformity with all relevant Directives.

Certified:



Chad Moe  
Sr. Engineering Manager  
8111 Lyndale Ave. South  
Bloomington, MN 55420, USA  
October 17, 2022

Authorized Representative:

Marcel Dutrieux  
Manager European Product Integrity  
Toro Europe NV  
Nijverheidsstraat 5  
2260 Oevel  
Belgium

# UK Declaration of Incorporation

The Toro Company, 8111 Lyndale Avenue South, Bloomington, MN, USA declares that the following unit(s) conform(s) to the directives listed, when installed in accordance with the accompanying instructions onto certain Toro models as indicated on the relevant Declarations of Conformity.

Model No.	Serial No.	Product Description	Invoice Description	General Description	Regulation
22420	404320000 and Up	Bore Drive Head Attachment	BORE DRIVE HEAD ATTACHMENT CE	Compact Utility Loader	S.I. 2008 No. 1597

Relevant technical documentation has been compiled as required per Schedule 10 of S.I. 2008 No. 1597.

We will undertake to transmit, in response to requests by national authorities, relevant information on this partly completed machinery. The method of transmission shall be electronic transmittal.

This machinery shall not be put into service until incorporated into approved Toro models as indicated on the associated Declaration of Conformity and in accordance with all instructions, whereby it can be declared in conformity with all relevant Directives.

This declaration has been issued under the sole responsibility of the manufacturer.  
The object of the declaration is in conformity with relevant UK legislation.



Chad Moe  
Sr. Engineering Manager  
8111 Lyndale Ave. South  
Bloomington, MN 55420, USA  
October 17, 2022

Authorized Representative:

Marcel Dutrieux  
Manager European Product Integrity  
Toro U.K. Limited  
Spellbrook Lane West  
Bishop's Stortford  
CM23 4BU  
United Kingdom

## **European Privacy Notice**

### **The Information Toro Collects**

Toro Warranty Company (Toro) respects your privacy. In order to process your warranty claim and contact you in the event of a product recall, we ask you to share certain personal information with us, either directly or through your local Toro company or dealer.

The Toro warranty system is hosted on servers located within the United States where privacy law may not provide the same protection as applies in your country.

**BY SHARING YOUR PERSONAL INFORMATION WITH US, YOU ARE CONSENTING TO THE PROCESSING OF YOUR PERSONAL INFORMATION AS DESCRIBED IN THIS PRIVACY NOTICE.**

### **The Way Toro Uses Information**

Toro may use your personal information to process warranty claims, to contact you in the event of a product recall and for any other purpose which we tell you about. Toro may share your information with Toro's affiliates, dealers or other business partners in connection with any of these activities. We will not sell your personal information to any other company. We reserve the right to disclose personal information in order to comply with applicable laws and with requests by the appropriate authorities, to operate our systems properly or for our own protection or that of other users.

### **Retention of your Personal Information**

We will keep your personal information as long as we need it for the purposes for which it was originally collected or for other legitimate purposes (such as regulatory compliance), or as required by applicable law.

### **Toro's Commitment to Security of Your Personal Information**

We take reasonable precautions in order to protect the security of your personal information. We also take steps to maintain the accuracy and current status of personal information.

### **Access and Correction of your Personal Information**

If you would like to review or correct your personal information, please contact us by email at [legal@toro.com](mailto:legal@toro.com).

## **Australian Consumer Law**

Australian customers will find details relating to the Australian Consumer Law either inside the box or at your local Toro Dealer.

# California Proposition 65 Warning Information

## What is this warning?

You may see a product for sale that has a warning label like the following:



**WARNING: Cancer and Reproductive Harm—[www.p65Warnings.ca.gov](http://www.p65Warnings.ca.gov).**

## What is Prop 65?

Prop 65 applies to any company operating in California, selling products in California, or manufacturing products that may be sold in or brought into California. It mandates that the Governor of California maintain and publish a list of chemicals known to cause cancer, birth defects, and/or other reproductive harm. The list, which is updated annually, includes hundreds of chemicals found in many everyday items. The purpose of Prop 65 is to inform the public about exposure to these chemicals.

Prop 65 does not ban the sale of products containing these chemicals but instead requires warnings on any product, product packaging, or literature with the product. Moreover, a Prop 65 warning does not mean that a product is in violation of any product safety standards or requirements. In fact, the California government has clarified that a Prop 65 warning "is not the same as a regulatory decision that a product is 'safe' or 'unsafe.'" Many of these chemicals have been used in everyday products for years without documented harm. For more information, go to <https://oag.ca.gov/prop65/faqs-view-all>.

A Prop 65 warning means that a company has either (1) evaluated the exposure and has concluded that it exceeds the "no significant risk level"; or (2) has chosen to provide a warning based on its understanding about the presence of a listed chemical without attempting to evaluate the exposure.

## Does this law apply everywhere?

Prop 65 warnings are required under California law only. These warnings are seen throughout California in a wide range of settings, including but not limited to restaurants, grocery stores, hotels, schools, and hospitals, and on a wide variety of products. Additionally, some online and mail order retailers provide Prop 65 warnings on their websites or in catalogs.

## How do the California warnings compare to federal limits?

Prop 65 standards are often more stringent than federal and international standards. There are various substances that require a Prop 65 warning at levels that are far lower than federal action limits. For example, the Prop 65 standard for warnings for lead is 0.5 µg/day, which is well below the federal and international standards.

## Why don't all similar products carry the warning?

- Products sold in California require Prop 65 labelling while similar products sold elsewhere do not.
- A company involved in a Prop 65 lawsuit reaching a settlement may be required to use Prop 65 warnings for its products, but other companies making similar products may have no such requirement.
- The enforcement of Prop 65 is inconsistent.
- Companies may elect not to provide warnings because they conclude that they are not required to do so under Prop 65; a lack of warnings for a product does not mean that the product is free of listed chemicals at similar levels.

## Why does Toro include this warning?

Toro has chosen to provide consumers with as much information as possible so that they can make informed decisions about the products they buy and use. Toro provides warnings in certain cases based on its knowledge of the presence of one or more listed chemicals without evaluating the level of exposure, as not all the listed chemicals provide exposure limit requirements. While the exposure from Toro products may be negligible or well within the "no significant risk" range, out of an abundance of caution, Toro has elected to provide the Prop 65 warnings. Moreover, if Toro does not provide these warnings, it could be sued by the State of California or by private parties seeking to enforce Prop 65 and subject to substantial penalties.



**Count on it.**