



MODEL NO. 20438 - 4900001 & UP
MODEL NO. 20439 - 4900001 & UP

OPERATOR'S
MANUAL

21" RECYCLER® II SUPER PRO®
MOWER

ENGLISH



SAFETY INSTRUCTIONS

This mower meets or exceeds CPSC blade safety requirements for walk behind rotary mowers and the B71.1-1990 specifications of the American National Standards Institute. Improper use or maintenance by the operator or owner can result in injury. To reduce the potential for injury, comply with these safety instructions and always pay attention to the safety alert symbol which means CAUTION, WARNING OR DANGER — "personal safety instruction." Failure to comply with the instruction may result in personal injury.

WARNING: Engine exhaust contains carbon monoxide which is an odorless, deadly poison. Carbon monoxide is also known to the State of California to cause birth defects. Do not run engine indoors or in an enclosed area.

BEFORE OPERATING

1. Read this manual carefully before operating the mower. Become familiar with the controls and proper use of the mower. Never allow children under 16 years of age to operate the mower. Never allow adults to operate mower without proper instructions.
2. The operator of the mower is responsible for keeping everyone, especially children and pets, away from area of operation. Thoroughly inspect area where mower will be used and remove sticks, stones, wire, and debris that could be picked up and thrown by mower. Watch for foreign objects while mowing.
3. Wear long pants and substantial shoes. Do not operate mower while wearing open-toed shoes, jewelry, loose clothing or when barefoot.
4. Always wear safety glasses or eye shields during operation to protect eyes from foreign objects that may be thrown from the machine.
5. Check fuel level before starting engine. Because fuel is highly flammable, handle it carefully.
 - A. Use an approved fuel container.
 - B. Fill fuel tank outdoors, not indoors. **NEVER ADD FUEL TO AN ENGINE THAT IS RUNNING OR HOT.**
 - C. Install gas cap on fuel container and gas tank, and wipe up any spilled gasoline before starting engine.
6. Keep all guards, shields, safety devices, cover-deflector assembly, optional grass catcher, optional

side discharge chute or optional discharge tunnel plug in place.

7. Repair or replace damaged parts, including decals. Check all safety devices before each use.
8. Traction drive and blade are designed to stop when control bar is released. Ensure control and brake function properly before each use of mower.

WHILE OPERATING

9. Do not run engine indoors.
10. Always maintain secure footing. Keep a firm grip on the handle and walk; never run. Never operate mower in wet grass. Mow only in daylight or in good artificial light.
11. Mow across the face of slopes; never up and down. Use extreme caution when changing direction on slopes. Wear skid resistant shoes on slopes. Do not mow excessively steep slopes.
12. Keep face, hands, and feet away from the mower housing and cutter blade when the engine is running. Blade can cause injury to hands and feet. Stay behind the handle until the engine stops.
13. Since the blade rotates for a few seconds after the blade control bar is released, stay behind the handle until all moving parts stop.
14. After striking a foreign object or if mower vibrates abnormally, stop engine and remove wire from spark plug. Check mower for damage and make all repairs before using mower again. If major repairs are ever needed or if assistance is desired, contact your local Authorized TORO Service Dealer.
15. Stop the engine and wait for all moving parts to stop before adjusting the height-of-cut.
16. Stop the blade when pushing the mower outside the lawn area.
17. Stop engine before leaving the operator's position—behind the handle. Disconnect wire from spark plug if mower will be unattended.



SAFETY INSTRUCTIONS

18. Do not touch engine while it is running or shortly after it is stopped because engine will be hot enough to cause a burn.

19. Refuel only when engine is cool.

20. If mower must be lifted to be transported, turn off engine and stay behind the handle until all moving parts stop.

MAINTENANCE

21. Perform only those maintenance instructions described in this manual. If major repairs are ever needed or if assistance is desired, contact your local Authorized TORO Service Dealer.

22. Before mower is cleaned, inspected, serviced, or adjusted, stop engine and disconnect wire from spark plug. Keep wire away from plug to prevent accidental starting.

23. To ensure the mower is in safe operating condition, frequently check and keep all nuts, bolts, and

screws tight. Ensure blade nuts are tightened to 15–27 ft–lb (20–37 N·m).

24. When servicing blade, refer to blade maintenance section for correct installation and servicing procedures.

25. To reduce fire hazard, keep engine free of excessive grease, grass, leaves, and accumulations of dirt.

26. Allow engine to cool before storing mower in any enclosure. Do not store mower near any open flame or where gasoline fumes may be ignited by a spark.

27. Do not overspeed the engine by changing governor settings.

28. At the time of manufacture, the mower conformed to the safety standards in effect for rotary mowers. To ensure best performance and continued safety certification of the mower, use genuine TORO replacement parts and accessories. Replacement parts and accessories made by other manufacturers may result in non-conformance with the safety standards, and that could be dangerous.



SAFETY DECALS AND INSTRUCTIONS

Safety decals and instructions are easily visible to the operator and are located near any area of potential danger. Replace any decal that is damaged or lost.



ON MOWER HOUSING
(Part No. 92-5429)



UNDER COVER – DEFLECTOR
ASSEMBLY ON MOWER DECK
(Part No. 92-1703)

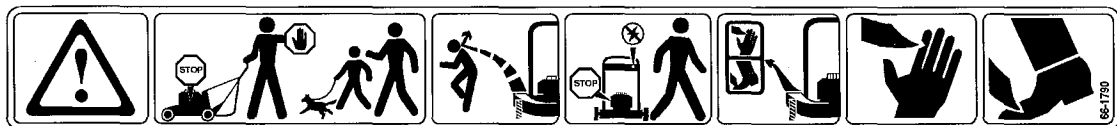

ON REAR OF CONTROL PANEL
(Part No. 66-1790)



ON TOP OF COVER – DEFLECTOR
ASSEMBLY ON MOWER DECK
(Part No. 92-1708)

SAFETY DECALS AND INSTRUCTIONS

STARTER



HORS CIRCUIT

MODE D'EMPLOI

POUR DÉMARRER: POSITIONNER LE RÉGULATEUR SUR STARTER. TOURNER LA CLEF. RELÂCHER LA CLEF LORSQU'É LE MOTEUR DÉMARRE OU APRÈS AVOIR ESSAYÉ DE LANCER LE MOTEUR PENDANT TROIS SECONDES. QUAND LE MOTEUR DÉMARRE, METTRE LE RÉGULATEUR SUR LA POSITION RAPIDE.

POUR ENGAGER LA LAME: ABAISSER LA BARRE DE CONTRÔLE ET LA RELEVER JUSQU'À LA POSITION INTERMÉDIAIRE.

POUR CONDUIRE LA TONDEUSE: RESSERER LA BARRE DE CONTRÔLE VERS L'AVANT.

POUR ARRÊTER LA LAME OU ARRÊTER LA TONDEUSE: RELÂCHER LA BARRE DE CONTRÔLE.

POUR ÉTEINDRE LE MOTEUR: METTRE LE RÉGULATEUR SUR LA POSITION HORS CIRCUIT.

CONDUIRE

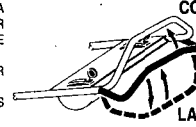

POSITION INTERMÉDIAIRE

LAME

ATTENTION  **LIRE LES INSTRUCTIONS D'UTILISATION ET DE SÉCURITÉ DANS LE GUIDE DE L'UTILISATEUR. AFIN D'OBTENIR UN AUTRE GUIDE, ENVOYER LES NUMÉROS DE MODÈLE ET DE SÉRIE À: TORO CO., 8111 LYNDALE AVE. S., BLOOMINGTON, MN 55420-1195**

RÉGULATEUR

VITESSE PAR RAPPORT AU SOL

3

2

1

N

92 - 2291

(Model 20438)

ON CONTROL PANEL (Part No. 92-2291)

STARTER



HORS CIRCUIT

MODE D'EMPLOI

POUR DÉMARRER: METTRE LE RÉGULATEUR SUR LA POSITION STARTER. TIRER SUR LA CORDE. LORSQUE LE MOTEUR DÉMARRE, BAISSER LA BARRE DE CONTRÔLE ET LA RELEVER À NOUVEAU JUSQU'À LA POSITION INTERMÉDIAIRE.

POUR CONDUIRE LA TONDEUSE: RESSERER LA BARRE DE CONTRÔLE VERS L'AVANT.

POUR ARRÊTER LA LAME OU ARRÊTER LA TONDEUSE: RELÂCHER LA BARRE DE CONTRÔLE.

POUR ÉTEINDRE LE MOTEUR: METTRE LE RÉGULATEUR SUR LA POSITION HORS CIRCUIT.

CONDUIRE

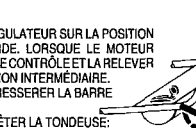

POSITION INTERMÉDIAIRE

LAME

ATTENTION  **LIRE LES INSTRUCTIONS D'UTILISATION ET DE SÉCURITÉ DANS LE GUIDE DE L'UTILISATEUR. AFIN D'OBTENIR UN AUTRE GUIDE, ENVOYER LES NUMÉROS DE MODÈLE ET DE SÉRIE À: TORO CO., 8111 LYNDALE AVE. S., BLOOMINGTON, MN 55420-1195**

RÉGULATEUR

VITESSE PAR RAPPORT AU SOL

3

2

1

N

92 - 4954

(Model 20439)

ON CONTROL PANEL (Part No. 92-4954)

TABLE OF CONTENTS

	Page		Page
Set-Up Instructions	4	Adjusting Blade Brake Cable	15
Before Operating	5	Charging Battery	15
Recycling Tips	6	Disposing of Battery	16
Operating Instructions	7	Cleaning Mower	16
Maintenance	12	Cleaning Blade Brake Clutch Shield	17
Servicing Air Cleaner	12	Preparing Mower For Storage	17
Replacing Spark Plug	12	Optional Equipment	18
Draining Gasoline	13	Product Identification	18
Changing Crankcase Oil	13	Toro Service Support	18
Adjusting Throttle	13	The Toro Starting Guarantee	19
Adjusting Wheel Drive	13	Guaranteed To Start Maintenance Record	21
Inspecting/Removing/Sharpening Blade	14	The Toro Total Coverage Guarantee	Back Page
Lubrication	15		

SET-UP INSTRUCTIONS

INSTALL HANDLE

1. The mowers are shipped from the factory with filler between the upper and lower handle joints to prevent shipping and assembly damage. Align upper and lower handles and remove the filler with a pliers.
2. The left handle knob is shipped from the factory on the outside of the handle (Fig. 1). Remove the left knob and bolt. Reinstall knob and bolt on inside of handle (Fig. 2). Both handle knobs should be positioned on the inside of the handles. Tighten handle knobs.

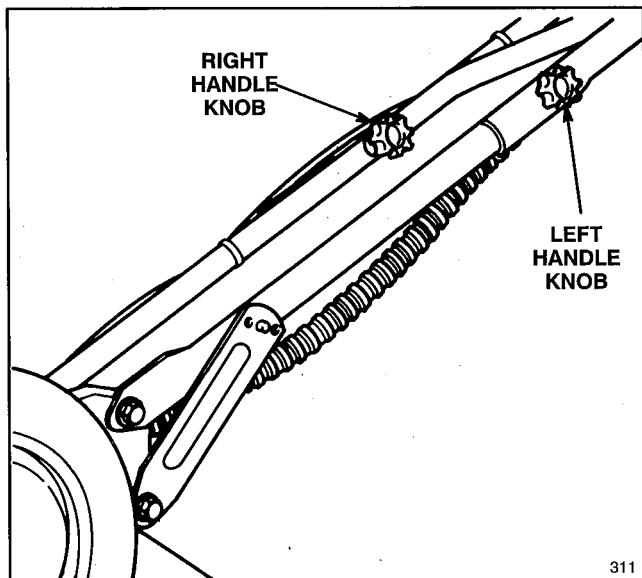

Figure 1

3. Move handle latches slightly outward so they will not be in the way when pivoting the handle backward into the operating position (Fig. 2).
4. Pivot handle backward. Move handle latches inward while snapping handle stud into center hole of handle latch (Fig. 2). If a handle latch does not fit tightly against the handle tube, remove latch from handle stud, bend the latch inward, and reattach to handle stud. Repeat as necessary to ensure a tight fit between latch and handle.

Note: if handle height is not satisfactory, adjust by placing handle stud (Fig. 2) into a different hole. Tighten handle knobs.

5. Ensure control cables (Fig. 2) are to the rear and inside of handles.

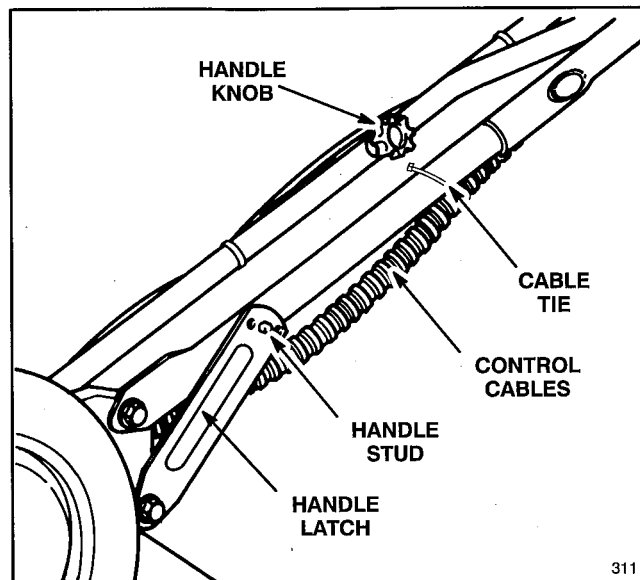

Figure 2

INSTALL BATTERY (electric start model only)

1. CHARGE BATTERY—Refer to Charging Battery, page 15. Slide battery, decal side up, between mounting tabs on back of control panel and connect wires (Fig. 3). Insert key into switch when ready to start engine.

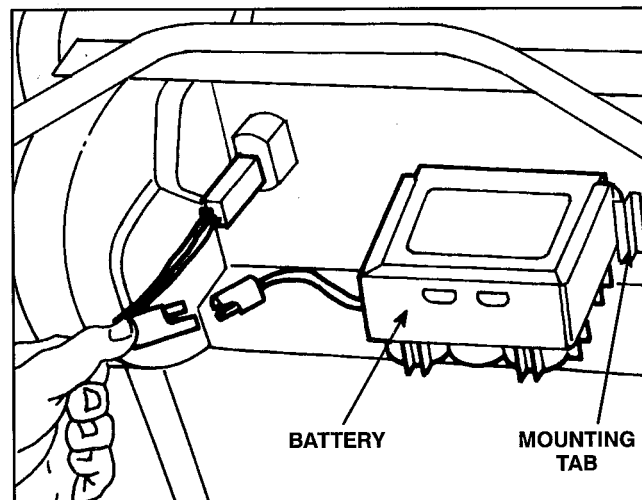

Figure 3

INSPECT GAS TANK FOR PLUG

1. Unscrew gas tank cap. If there is a plastic plug covering the gas tank opening, remove the plug and discard it. Reinstall gas tank cap.

BEFORE OPERATING

FILL CRANKCASE WITH OIL (Fig. 4)

Fill crankcase with SAE 30 oil until oil level reaches FULL mark on dipstick as shown in Figure 4. 10W-30 oil may be substituted if SAE 30 is not available. The maximum crankcase capacity is 25 ounces (0.75 liters) of oil. Use any high quality detergent oil having the American Petroleum Institute (API) "service classification"—SE, SF or SG.

Before each use, ensure oil level is between ADD and FULL marks on dipstick. Add oil if level is low.

1. Position mower on level surface and clean around oil dipstick.
2. Remove dipstick by rotating cap counterclockwise 1/4 turn.
3. Wipe dipstick and insert it into filler neck. Rotate cap clockwise 1/4 turn. Then remove dipstick and check level of oil. If level is low, add only enough oil to raise level to FULL mark on dipstick. **DO NOT FILL ABOVE FULL MARK BECAUSE ENGINE COULD BE DAMAGED WHEN STARTED. POUR OIL SLOWLY.**

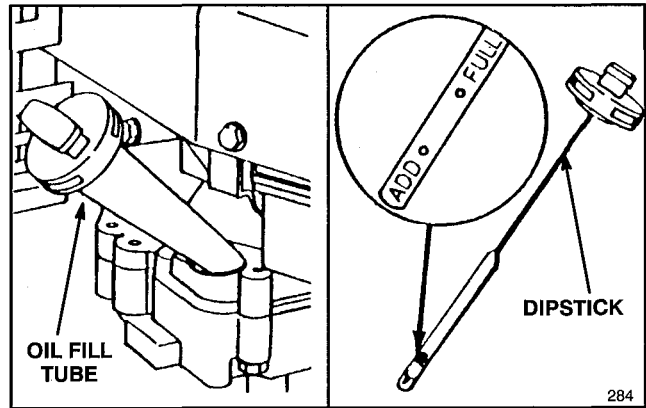

Figure 4

4. Insert dipstick into filler neck and rotate cap clockwise 1/4 turn to lock.

Note: Check oil level each time mower is used or after every 5 operating hours. Initially, change oil after the first 2 hours of operation; thereafter, change oil after every 25 hours of operation. Refer to Changing Crankcase Oil, page 13. More frequent oil changes are required in dusty or dirty conditions.



WARNING

DANGER: Gasoline is extremely flammable and explosive under certain conditions. Do not smoke when handling fuel and keep fuel far away from open flames and sparks. Never buy more than a 30 day supply of gasoline. Store it in an approved container. Keep gasoline out of reach of children.

Refuel outdoors and only when engine is cold. Fill tank to within 1/4" to 1/2" (6 to 13 mm) from top of tank, not into filler neck. This space is for expansion of fuel. Use funnel or spout to prevent spilling. Wipe up any spilled gas.

FILL FUEL TANK WITH GASOLINE

Note: The Toro Company strongly recommends the use of fresh, clean, **UNLEADED** regular grade gasoline in Toro gasoline powered products. Unleaded gasoline burns cleaner, extends engine life, and promotes good starting by reducing the build-up of combustion chamber deposits. Leaded gasoline can be used if unleaded is not available.

Toro also recommends that Toro Stabilizer/Conditioner be used regularly in all Toro gasoline powered products during operation and storage seasons. Toro Stabilizer/Conditioner cleans the engine during operation and prevents gum-like varnish deposits from forming in the engine during periods of storage.

1. Clean around fuel tank cap (Fig. 6) and remove cap from tank. Do not fill tank full. Using unleaded gasoline, fill fuel tank to within 1/4" to 1/2" (6 to 13 mm) from top of tank, not into the filler neck. This space is for expansion of fuel.

2. Install fuel tank cap and wipe up any spilled gasoline.

IMPORTANT: DO NOT MIX OIL WITH THE GASOLINE. NEVER USE METHANOL, GASOLINE CONTAINING METHANOL, GASOHOL CONTAINING MORE THAN 10% ETHANOL, PREMIUM GASOLINE OR WHITE GAS BECAUSE ENGINE FUEL SYSTEM DAMAGE COULD RESULT.

DO NOT USE FUEL ADDITIVES OTHER THAN THOSE MANUFACTURED FOR FUEL STABILIZATION DURING STORAGE SUCH AS TORO'S STABILIZER/CONDITIONER OR A SIMILAR PRODUCT. TORO'S STABILIZER/CONDITIONER IS A PETROLEUM DISTILLATE BASED CONDITIONER/STABILIZER. TORO DOES NOT RECOMMEND STABILIZERS WITH AN ALCOHOL BASE SUCH AS ETHANOL, METHANOL OR ISOPROPYL. ADDITIVES SHOULD NOT BE USED TO TRY TO ENHANCE THE POWER OR PERFORMANCE OF MACHINE.

RECYCLING TIPS

GENERAL TIPS

Follow these instructions whether cutting grass or leaves for the best cutting results and lawn appearance:

- Maintain a **sharp blade** throughout the cutting season. Periodically file down nicks on blade.
- **Only mow dry grass or leaves.** Wet grass and leaves tend to clump on yard and may cause mower to plug or engine to stall. They also may be slippery to walk on and could cause you to slip and fall.



WARNING

- **Wet grass or leaves can cause you to slip and contact blade.**
- **Blade contact can seriously injure you.**
- **Mow only in dry conditions.**

- Set engine speed to fastest position. Maximum horsepower provides best cutting results.
- Clean clippings or leaves from underside of mower deck after each mowing.
- Keep engine in good running condition. Cutting and recutting requires more horsepower.
- Clean air filter more frequently. Cutting and recutting stirs up more clippings and dust which clogs the air filter and reduces engine performance.

CUTTING GRASS

- Grass grows at different rates at different times of the year. In the heat of the summer, it is generally best to cut grass at the C, D or E height-of-cut settings. Only about 1/3 of the grass blade should be cut off. Cutting below the C setting is not recommended unless grass is sparse or it is late fall when grass growth begins to slow down.
- When cutting grass over six inches tall, you may want to first mow using the highest height-of-cut setting and a slower walking speed; then mow again at a lower setting for best lawn appearance. If grass is too long and leaves clumps on top of lawn, mower may plug and cause engine to stall.
- Alternate mowing direction. This helps disperse clippings over lawn for even fertilization.

If the finished cut lawn appearance is unsatisfactory, try one or more of the following:

- Sharpen the blade.
- Walk at a slower pace while mowing.
- Raise the height-of-cut setting on your mower.
- Cut grass more frequently.
- Overlap cutting swaths instead of cutting a full swath with each pass.
- Mow across the marginal areas a second time.
- Set height-of-cut on front wheels one notch lower than rear wheels. (example: set front wheels at "C" setting and rear wheels at "D" setting)

CUTTING LEAVES

- When cutting is complete, always be sure that 50% of the lawn shows through the cut leaf cover. This may require one or more passes over the leaves.
- For light leaf coverage, position all wheels at the same height-of-cut setting.
- If there are more than five inches of leaves on lawn, set the front wheels one or two notches higher than the rear wheels. This makes it easier to feed leaves under mower deck.
- Walk at a slower mowing speed if leaves are not being cut up finely enough to be hidden down in the grass.
- If you cut up a lot of oak leaves, you might want to add lime to your grass in the spring. Lime reduces the acidity of oak leaves.

OPERATING INSTRUCTIONS

STARTING, STOPPING, AND SELF-PROPELLING

1. CONTROLS—Key switch (electric start model only), ground speed control, throttle, and blade/self-propelled control bar are on upper handle (Fig. 5). Fingertip starter is on top of engine (Fig. 6).

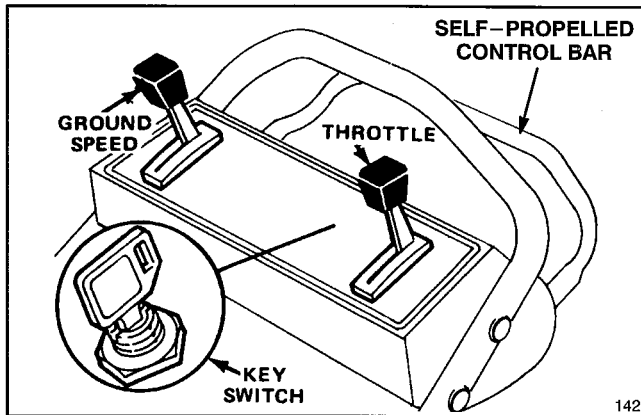

Figure 5

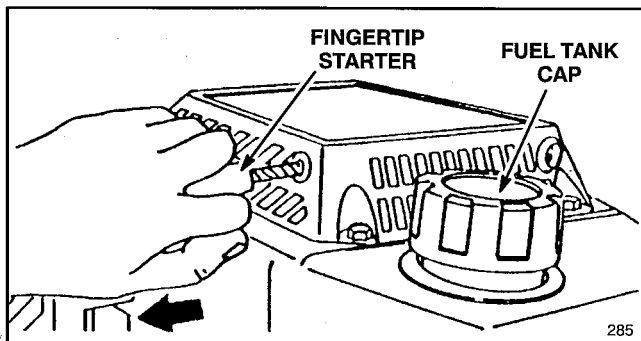

Figure 6

2. Push spark plug wire onto spark plug (Fig. 18).

3. Move ground speed control to **N** (neutral) position.

4a. KEY-ELECTRIC STARTING (electric start model only)—Move throttle to CHOKE. Turn key to START and release when engine begins running. When engine starts, remove throttle from CHOKE and regulate engine speed between **F** (FAST) and **S** (SLOW). If the battery's charge is too weak to start the engine, the engine can be started with the fingertip starter (Fig. 6).

4b. MANUAL STARTING—Move throttle to CHOKE. Brace yourself and mower securely by placing your foot on the top left side of mower housing where it says "PLACE FOOT HERE WHEN STARTING". Pull fingertip starter out until positive engagement results; then pull vigorously to start the engine. When engine starts, move throttle from CHOKE and regulate engine speed between **F** (FAST) and **S** (SLOW).

5. GROUND SPEED (Fig. 5)—Ground speed varies depending on distance between control bar and handle. The mower has three ground speeds: number "1" is slow, "2" is medium, and "3" is a fast walking pace. Move ground speed control to desired setting. Ground speed can be varied by increasing or decreasing distance between control bar and handle. Lower control bar to slow mower when making a turn or if mower is moving too fast for you. If you lower control bar too far, the mower will stop self-propelling. Squeeze control bar closer to handle to increase ground speed. When control bar is tight against handle, mower will self-propel at maximum ground speed. Move ground speed control to **N** (neutral) position when using the mower for trimming and whenever leaving mower.

Note: Do not shift speeds while control bar is squeezed against handle in the "C" (drive) position (Fig. 7); the transmission could burn out. Move control bar to the mid position (Fig. 7) when changing ground speed.

6. BLADE AND TRACTION OPERATION (Fig. 7)—Move control bar down to "A" and raise to "B" to engage blade. Squeeze control bar against handle "C" to drive. To disengage traction drive but keep blade engaged, gradually release control bar to mid position. To self-propel with blade disengaged, simply squeeze control bar against handle, eliminating downward movement necessary for blade engagement.

NOTE: The drive wheels are equipped with free-wheeling clutches which enable the mower to be pulled rearward easier when the wheel drive is disengaged. To disengage the clutches, mower must be pushed forward at least 1" after wheel drive operation has stopped.

7. STOPPING (Fig. 7)—Release control bar to stop blade and traction drive. Move ground speed control to **N** (neutral) position. To stop engine, move throttle to OFF. Remove key from switch on electric start model or pull wire off spark plug if mower will be unattended or not used.

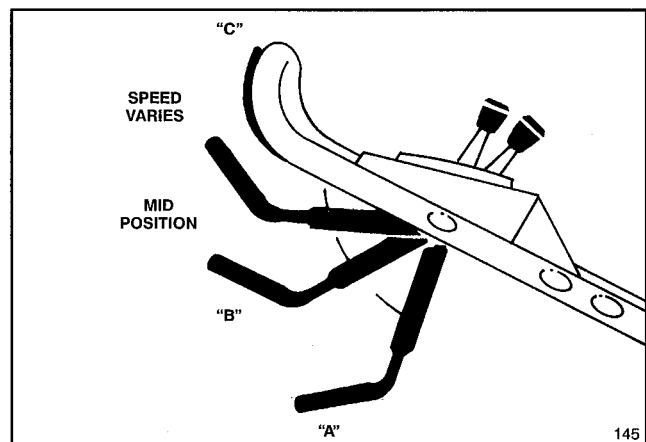

Figure 7

OPERATING INSTRUCTIONS

SETTING HEIGHT-OF-CUT

Toro's exclusive SmartWheel™ provides a simple method for determining the proper cutting height.

The SmartWheel has two cutting scales — SPARSE/NORMAL and LUSH — to ensure the best height-of-cut setting in any mowing condition. Use the SPARSE/NORMAL scale during the warm summer season for the majority of your mowing. The LUSH scale is for thick, moist, succulent grass that grows most often in the spring or when grass is fertilized and watered frequently.

In general, it is recommended that:

- Grass length should usually be cut at the C, D or E settings or maintained at two to three inches in height.
- Cutting below the C setting is not recommended unless grass is sparse or it is late fall when grass growth begins to slow down. When cutting long grass, you may need to use a higher height-of-cut setting and a slower walking speed; then recut the grass at a more normal setting. If grass is too long and leaves clumps on top of lawn, mower may plug and cause engine to stall.
- The SmartWheel™ calculates the proper setting to ensure that no more than 1/3 of the grass blade is cut off.

 **DANGER**

- **Adjusting height-of-cut levers could bring hands into contact with moving blade.**
- **Contact with moving blade could cause serious personal injury.**
- **Do not adjust height-of-cut settings when engine is running and blade is rotating.**
- **Do not put fingers under housing to lift mower when adjusting height-of-cut levers.**

1. Before starting the engine and beginning to mow, push the mower into the grass. Stop when the words SPARSE/NORMAL and LUSH are upright on the SmartWheel design on the rear left wheel (Fig. 8).

EN-8

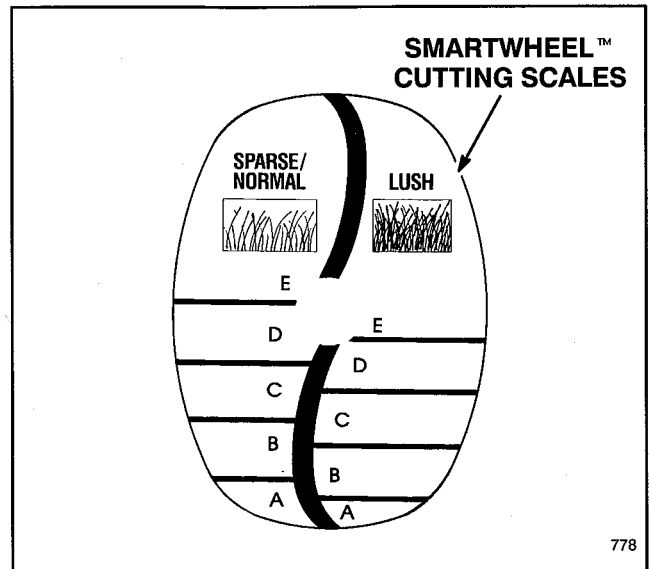

Figure 8

2. Using the color coded SmartWheel design (Fig. 8), compare the tips of the grass blades to the colors/letters on the wheel. Whichever color/letter the tips of the grass blades correspond with is the proper cutting height.

3. Squeeze the mower's height-of-cut lever toward the wheel and move it to the corresponding color/letter on the mower housing (Fig. 9). For easier adjustment, lift housing up so wheel is off ground. **Do not put fingers under housing when lifting.** Ensure pin on height-of-cut lever engages slot in housing. Adjust all wheels to the same color/letter setting.

Note: Front wheels can be adjusted to 1/2 inch. Move adjusting lever past "A" and release pin into slot in housing.

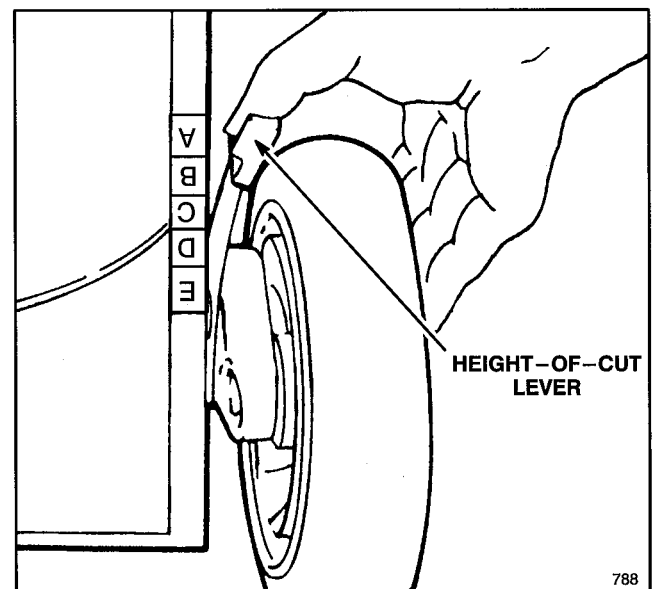

Figure 9

OPERATING INSTRUCTIONS

CHECK BLADE BRAKE CLUTCH OPERATION

Check the control bar before each use to ensure the Blade Brake Clutch (BBC) safety system is operating properly.

A: Normal Control Bar Operation Test

1. With engine off, wheel mower onto a paved surface in a nonwindy area.
2. Put all four wheels in "E" height-of-cut position (Fig. 9).
3. Put ground speed selector in **N** (neutral) position.
4. Take a half sheet of newspaper and crumple it into a ball small enough to go under deck (approx. three inches in diameter) (Fig. 10).
5. Place ball of newspaper five inches in front of mower (Fig. 10).

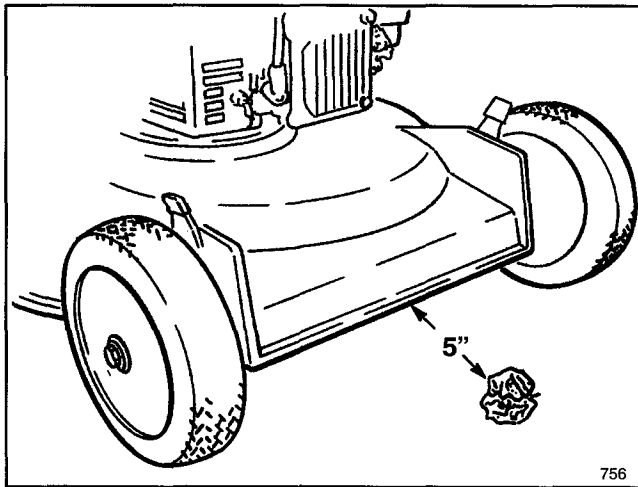

Figure 10

6. Start the engine.
7. Push control bar down to lowest position (Fig. 11).

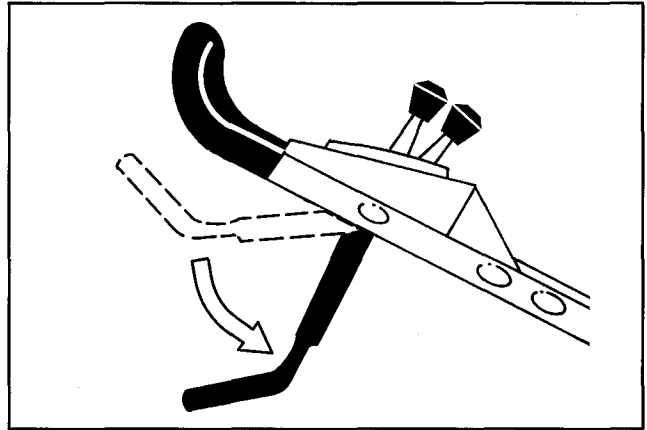

Figure 11

8. Lift control bar to the normal "blade engaged" position (about one inch below the handle) (Position A, Fig. 12). The "fan" noise indicates that the mower blade is turning.

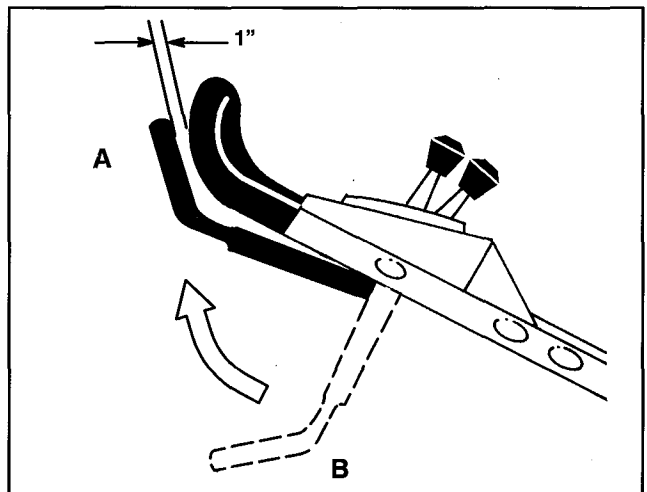

Figure 12

9. Release the control bar (Position B, Fig. 12). A "bang" should be heard. The blade should stop running in three seconds.
10. Immediately push the mower over the newspaper ball.
11. Turn off the engine.
12. Walk around the mower to check for the newspaper ball. If the ball did not go under the deck, repeat steps 5–11.
13. Pull mower away from the newspaper. If the newspaper ball unravels or is shredded, it indicates that the blade has not stopped as it should, resulting in an unsafe operating condition. Contact an Authorized Toro Service Dealer for an inspection at your earliest convenience. However, to detect BBC system deterioration **before** it affects normal operation, we also ask you to perform Special Control Bar Test B which follows.

OPERATING INSTRUCTIONS

B: Special Control Bar Test

1. With the engine off, wheel mower onto a paved surface in a nonwindy area.
2. Put all four wheels in "E" height-of-cut position (Fig. 13).

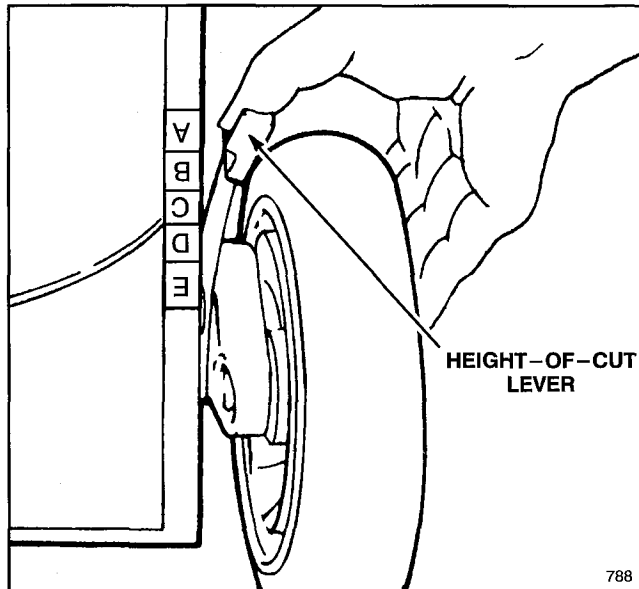

Figure 13

3. Put ground speed selector in **N** (neutral) position.
4. Take a half sheet of newspaper and crumple it into a ball small enough to go under the deck (approx. three inches in diameter) (Fig. 14).
5. Place ball of newspaper five inches in front of mower (Fig. 14).
6. Start the engine.

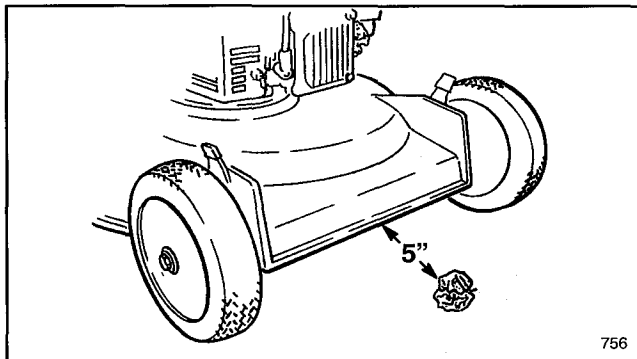

Figure 14

7. Push control bar down to lowest position (Fig. 15, position B).

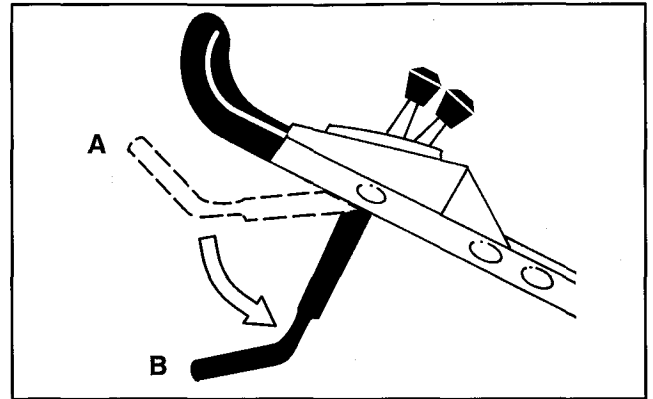

Figure 15

8. Bring the control bar up into the mid position (about 5 inches below the handle cross bar) (Fig. 16, position C).

NOTE: This intermediate position (C) is not the "natural" operating position of the control bar. However, it has proven to be useful in early detection of BBC sticking which could create an unsafe condition later in the life of the mower.

9. Release control bar (Fig. 16, position B).

NOTE: If a loud bang is heard, the control bar has been raised too high. Repeat steps 7, 8 and 9, but do not raise the control bar as high as in step 8.

10. Immediately push the mower over the newspaper ball.

11. Turn off the engine.

12. Walk around the mower to check for the newspaper ball. If the ball did not go under the deck, repeat steps 5–11.

13. Pull mower away from newspaper. If the newspaper ball unravels or is shredded, it indicates the system could be experiencing wear/deterioration which could result in an unsafe operating condition. Use care in operating the mower and BBC system and contact an Authorized Toro Service Dealer for an inspection of your mower at your earliest convenience. They will ensure that appropriate corrective measures are performed and your mower is restored to proper operating condition.

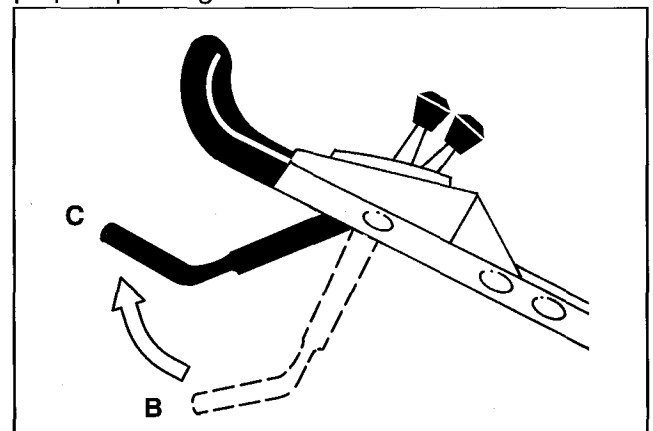

Figure 16

OPERATING INSTRUCTIONS



DANGER

- **If the Blade Brake Clutch system is inoperative, blade will continue to rotate when control bar is released. Contact with blade could occur.**
- **Blade contact can cause serious personal injury or death.**
- **Never use a BBC equipped power mower with an inoperative safety system.**
- **Return your lawn mower to your dealer for repair if a safety system fails to operate properly.**

SPECIAL NOTE: Whenever performing operations such as cleaning the mower, first stop the engine and disconnect the spark plug wire. As with any lawnmower, regardless of the safety features and blade stopping devices used, operators should keep all body parts away from the cutting blade area whenever the mower's engine is running, and keep bystanders away as well.

Should you require further information or assistance, feel free to contact us at:

The Toro Company
Attn: Consumer Service Department
8111 Lyndale Avenue South
Bloomington, MN 55420-1196
(612) 887-8255

If you purchase the optional Rear Bagging Kit (Model No. 59174), the grass bag can be used for an additional test to check the Blade Brake Clutch mechanism.

1. Install the empty grass bag on the discharge tunnel.
2. Start the engine.
3. Push the control bar (Fig. 15) down to the lowest position.
4. Lift the control bar to the normal "blade engaged" position, about one inch below the handle. The bag should begin to inflate which indicates the blade is engaged and rotating.
5. Release control bar. If the bag does not immediately deflate, it indicates the blade is still rotating. Deterioration of the Blade Brake Clutch mechanism may have set in, which could result in an unsafe operating condition. Have mower inspected by an Authorized TORO Service Dealer.

MAINTENANCE



CAUTION

- Engine could start accidentally.
- Accidental starting of engine could cause serious injury to operator or bystanders.
- Pull wire off spark plug and remove key from switch on electric start model before performing any maintenance or adjustments.

SERVICING AIR CLEANER

Normally, clean air cleaner after every 25 operating hours. More frequent cleaning is required when mower is operated in dusty or dirty conditions.

1. Stop engine and pull wire off spark plug (Fig. 18). Remove key from switch on electric start model.
2. Rotate knob securing air cleaner cover to engine until cover can be removed. Clean cover thoroughly (Fig. 17).
3. If outside of foam element is dirty, remove it from air cleaner body (Fig. 17). Clean thoroughly.
 - A. WASH foam element in a solution of liquid soap and warm water. Squeeze to remove dirt, but do not twist because foam may tear. Rinse thoroughly in clear water.
 - B. DRY by wrapping in a clean rag. Squeeze rag and foam element to dry.
 - C. SATURATE element with approximately 5 ounces (150 ml) of 10W-30 engine oil. Squeeze element to remove excess oil and to distribute oil thoroughly. A damp element is desirable.

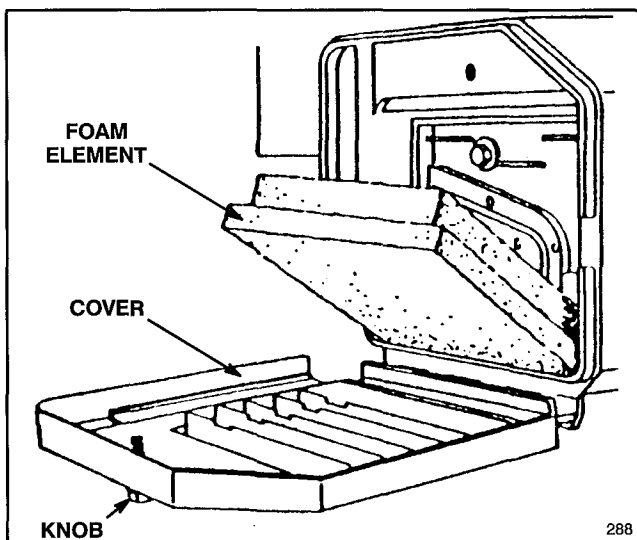

Figure 17

4. Reinstall foam element and air cleaner cover.

IMPORTANT: Do not operate engine without air cleaner element because extreme engine wear and damage will likely result.

REPLACING SPARK PLUG

Use a CHAMPION RC12YC spark plug or equivalent. Correct air gap is 0.030" (0.76 mm). Remove plug after every 25 operating hours and check its condition.

1. Stop engine and pull wire off spark plug (Fig. 18). Remove key from switch on electric start model.
2. Clean around spark plug and remove plug from cylinder head.

IMPORTANT: Replace a cracked, fouled, or dirty spark plug. Do not sand blast, scrape, or clean electrodes because engine damage could result from grit entering cylinder.

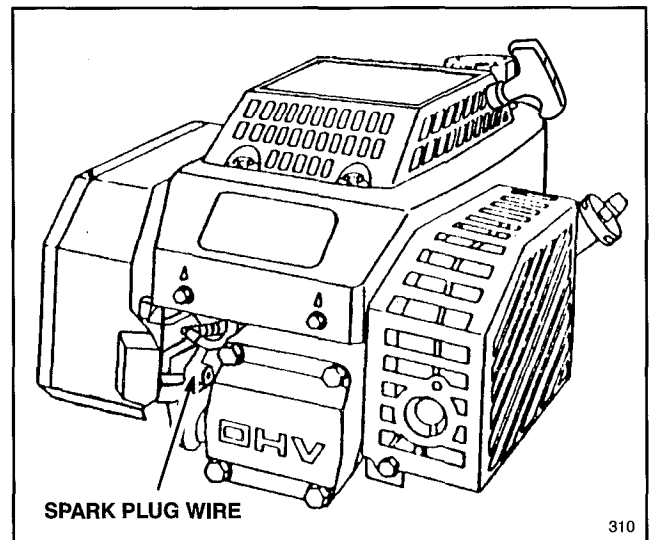

Figure 18

3. Set air gap at 0.030" (0.76 mm) (Fig. 19). Install correctly gapped spark plug and gasket seal. Tighten plug firmly to 14 ft-lb (19 N·m).

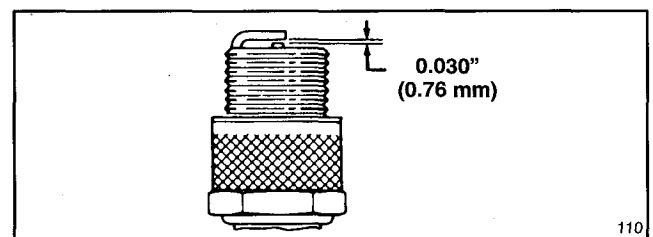

Figure 19

MAINTENANCE

DRAINING GASOLINE

1. Stop engine and pull wire off spark plug (Fig. 18). Remove key from switch on electric start model.
2. Remove cap from fuel tank and use pump-type syphon to drain fuel into clean gas can.

Note: This is the only procedure recommended for draining fuel.

CHANGING CRANKCASE OIL

Change oil after the first 2 operating hours and after every 25 hours thereafter. Since warm oil drains better and carries more contaminants than cold, run engine for a minute or so before draining oil.

1. Stop engine and pull wire off spark plug (Fig. 18). Remove key from switch on electric start model.
2. Drain gasoline from fuel tank: refer to Draining Gasoline, page 13.
3. Remove dipstick from oil fill tube and place a drain pan next to left side of mower.
4. Tip mower on its left side, allowing oil to drain into drain pan (Fig. 20).

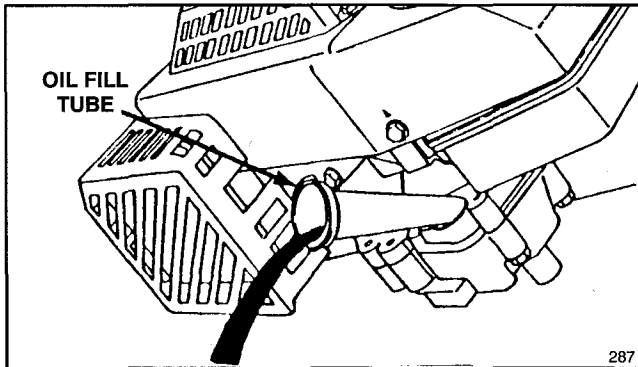

Figure 20

5. When oil is drained, return mower to upright position and add fresh oil to engine. Refer to Fill Crankcase With Oil, page 5.

ADJUSTING THROTTLE

Throttle control adjustment may be required if engine does not start or stop. Whenever a new throttle control cable is installed, throttle must be adjusted.

1. Stop engine and pull wire off spark plug (Fig. 18). Remove key from switch on electric start model.
2. Move throttle control to ⚡ (FAST) position.

3. Loosen cable clamp screw until throttle cable slides (Fig. 21).
4. Move throttle cable left or right until holes in throttle lever and throttle bracket align (Fig. 21).
5. Tighten cable clamp screw to lock adjustment in place.

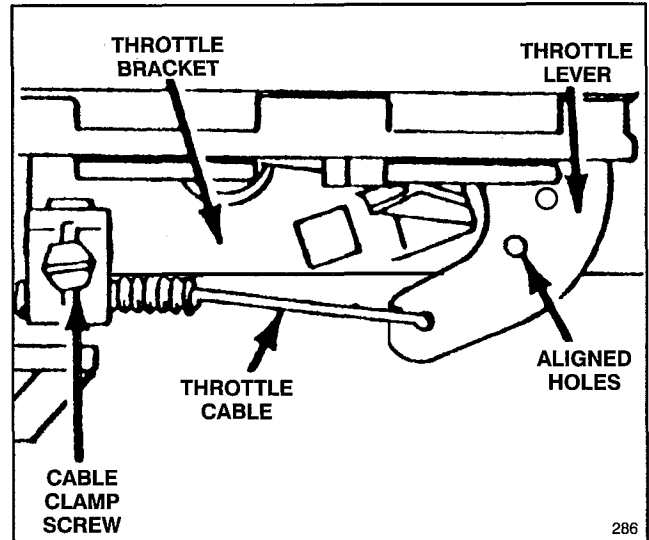

Figure 21

ADJUSTING WHEEL DRIVE

If mower does not self-propel or self-propels when control bar is more than 1-1/2 inches from the handle, adjust wheel drive control knob on rear of gear box.

1. Stop engine and pull wire off spark plug (Fig. 18). Remove key from switch on electric start model.
2. ADJUSTMENT (Fig. 22)—Rotate control knob clockwise 1/2 turn if mower does not self-propel. If mower creeps forward, rotate knob 1/2 turn counter-clockwise to loosen belt.

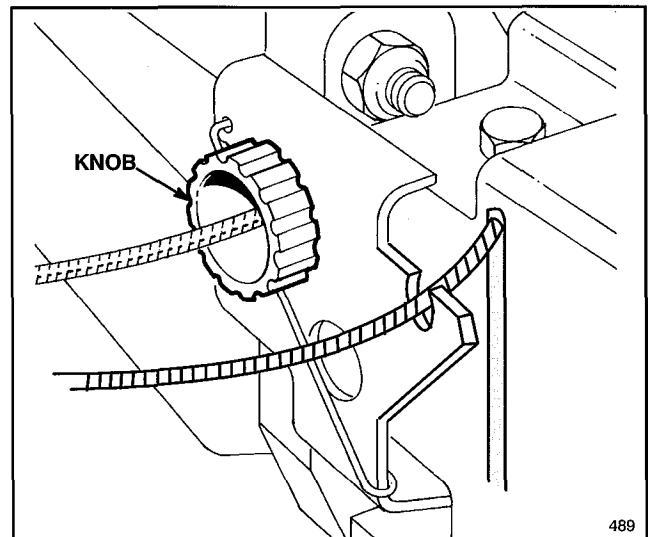

Figure 22

MAINTENANCE

3. **CHECK ADJUSTMENT**—Slowly pull mower backward while control bar is gradually moved toward handle. Adjustment is correct when rear wheels stop turning and control is about 1-1/2 inches from handle (Fig. 23).

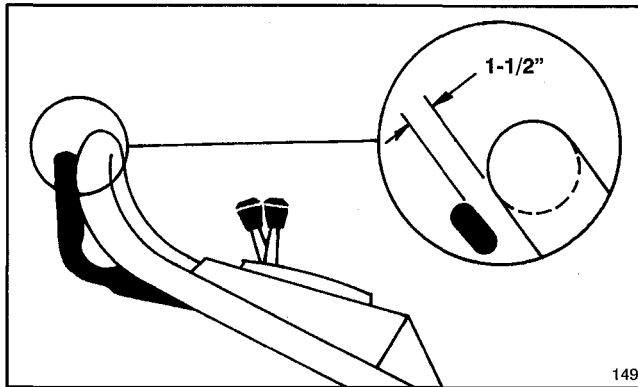

Figure 23

4. Repeat steps 2 and 3 until properly adjusted.

INSPECTING/REMOVING/SHARPENING BLADE

Always mow with a sharp blade. A sharp blade cuts cleanly and without tearing or shredding the grass blades like a dull blade.

1. Stop engine and pull wire off spark plug (Fig. 18). Remove key from switch on electric start model.
2. Drain gasoline from fuel tank; refer to Draining Gasoline, page 13.
3. Tip mower on its left side (Fig. 24). Avoid rotating blade as starting problems may result.

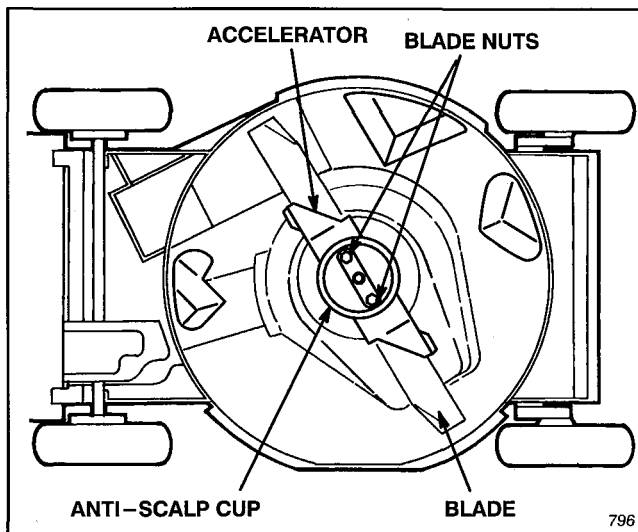

Figure 24

4. **INSPECTING BLADE**—Carefully examine blade for sharpness and wear, especially where flat and curved parts meet (Fig. 25A). Since sand and abra-

sive material can wear away the metal that connects the flat and curved parts of the blade, check blade before using the mower. If a slot or wear is noticed, (Fig. 25B & C), replace blade. Refer to step 5.

5. **REMOVING BLADE**—Grasp end of blade using a rag or thickly padded glove. Remove (2) blade nuts, anti-scalp cup, accelerator, and blade (Fig. 24).

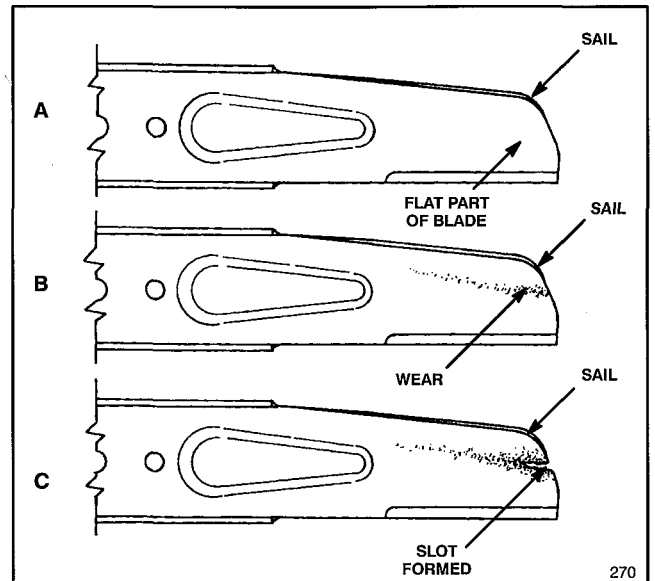

Figure 25

DANGER

- A worn or damaged blade could break and a piece of blade could be thrown into operator's or bystander's area.
- A thrown piece of blade could cause serious personal injury or death to operator or bystanders.
- Inspect blade periodically for wear or damage.
- Replace a worn or damaged blade.

NOTE: For best performance, install new blade before cutting season begins. During the year, file down small nicks to maintain the cutting edge.

6. **SHARPENING BLADE**—Using a file, sharpen top side of blade (side facing mower housing) and maintain original cutting angle (Fig. 26). The blade will remain balanced if the same amount of material is removed from both cutting edges.

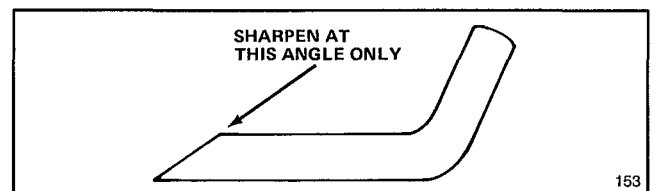

Figure 26

MAINTENANCE

IMPORTANT: Check balance of blade by putting it on a blade balancer. An inexpensive balancer can be purchased at a hardware store. A balanced blade will stay in a horizontal position and an unbalanced blade will settle to the heavy side. If the blade is not balanced, file more metal off cutting edge on heavy end of blade.

7. Install sharp, balanced blade, accelerator, anti-scalp cup, and (2) blade nuts. Sail part of blade must point toward top of mower housing to assure correct installation. Tighten the blade nuts to 15–27 ft–lb (20–37 N·m).



WARNING

- Operating mower without accelerator in place could cause blade to flex, bend or break.
- A broken blade could cause serious injury or death to operator or bystanders.
- Do not operate mower without accelerator.

LUBRICATION

After every 25 operating hours or when season ends, front and rear wheels must be lubricated.

1. Apply 2 or 3 drops of light oil on inside and outside of all wheel bolts. Spin wheels to distribute oil into bushings. Wipe up excess oil.
2. Move rear wheel height-of-cut levers to “C” setting. Wipe grease fittings with clean rag (Fig. 27). Install grease gun onto fitting and gently apply two or three pumps of #2 Multi-Purpose Lithium Base Grease.

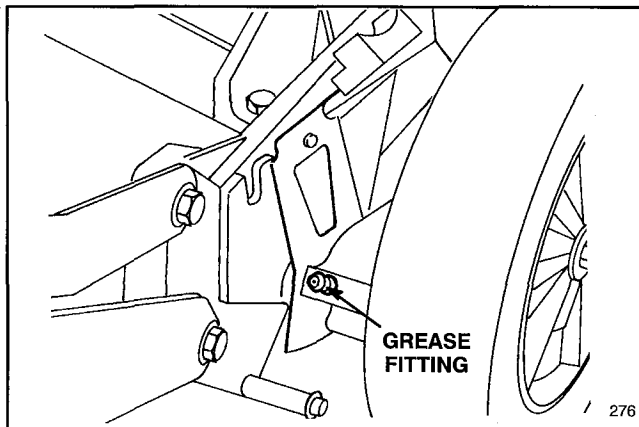

Figure 27

ADJUSTING BLADE BRAKE CABLE

Whenever a new blade brake cable assembly is installed, an adjustment is required.

1. Stop engine and pull wire off spark plug (Fig. 18). Remove key from switch on electric start model.

2. Loosen cable clamp screw until brake cable conduit slides (Fig. 28). Pull cable to remove slack, but do not put tension on spring. Tighten screw to lock adjustment in place.

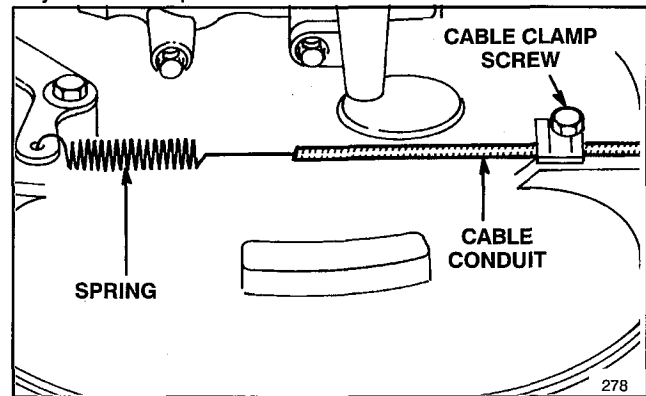

Figure 28

CHARGING BATTERY (electric start model only)

Although a new battery is not fully charged, a partial charge of 4 hours provides enough energy for several starts. However, a new battery must be charged for 72 continuous hours to ensure full charge. Also charge battery for 72 hours when mower is stored and in the spring. During normal operation, engine alternator keeps battery charged.

1. Stop engine and disconnect wire harness from battery terminal (Fig. 29).
2. If desired, battery can be removed by sliding it out of mounting tabs. However, removal is not required if mower can be positioned near an electrical outlet.
3. Connect TORO electro charger to battery and plug into 120VAC power outlet. After charging battery for specified time, unplug charger and disconnect from battery.

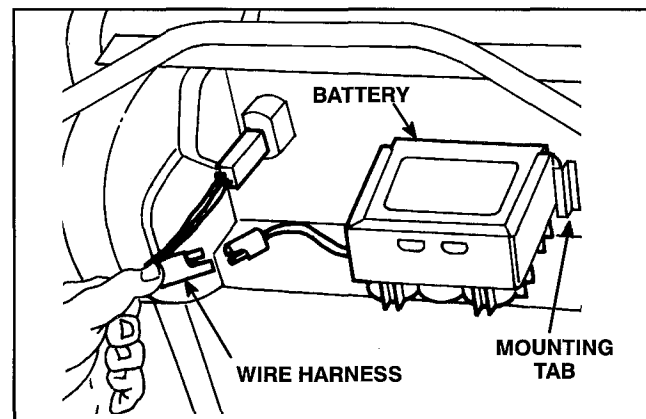

Figure 29

4. Connect wiring harness to battery terminal.

IMPORTANT: Only the TORO electro charger is recommended because other chargers could damage the battery. Always use charger indoors and charge battery at room temperature (+70° F) whenever possible. Do not charge battery longer than 72 hours because damage could result.

MAINTENANCE

DISPOSING OF BATTERY

(electric start model only)

DO NOT PLACE USED BATTERIES IN YOUR REGULAR TRASH!

THIS SEALED LEAD (ACID) BATTERY MUST BE COLLECTED, RECYCLED OR DISPOSED OF IN AN ENVIRONMENTALLY SOUND MANNER.

The incineration, landfilling or mixing of sealed lead (acid) batteries with the municipal solid waste stream is **PROHIBITED BY LAW** in some areas.

Return this battery to a federal or state approved sealed lead (acid) battery recycler. This may be where you purchased the battery.

Contact your local waste management officials for other information regarding the environmentally sound collection, recycling and disposal of this battery.

CLEANING MOWER

Underside of Mower Housing

To ensure best performance, keep underside of mower housing clean. Be especially careful to keep kickers free of debris (Fig. 31).

Washing Method

After every use, follow this procedure for washing debris out from the underside of the mower housing.

1. Position mower on a flat concrete or asphalt surface near a garden hose.
2. Start the engine.
3. Engage the blade.
4. Hold the running garden hose at handle level and direct water to flow on ground just in front of right rear tire (Fig. 30). The rotating blade will draw water under the housing and wash out clippings. Let the water run for a few minutes or until you no longer see clippings being washed out from under housing.

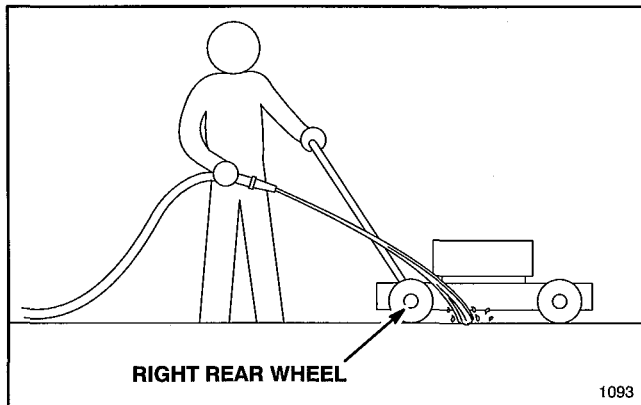

Figure 30

5. Disengage the blade.
6. Turn off the garden hose.

7. Restart mower and let it run for a few minutes to dry out moisture on the mower and its components. While the engine is running, engage and disengage the safety system and traction drive several times to dry them out.

Scraping Method

If washing does not remove all debris from under deck, tip mower and scrape it clean.

1. Pull wire off spark plug. Remove key from switch on electric start models.
2. Drain gasoline from fuel tank: refer to Draining Gasoline, page 13.
3. Tip mower on its left side (Fig. 31).

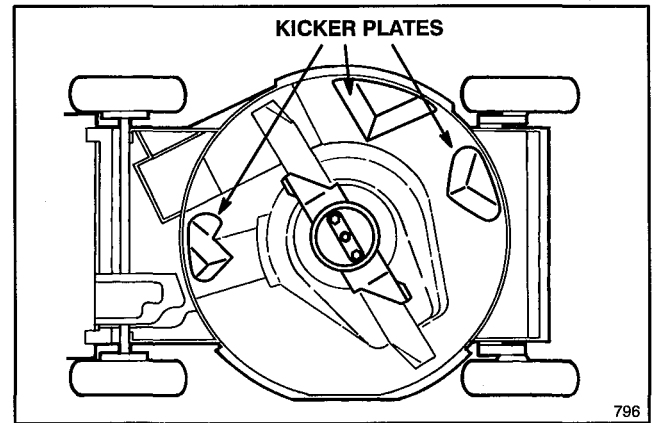

Figure 31

4. Remove dirt and grass clippings with a hard-wood scraper. Avoid burrs and sharp edges.
5. Turn mower upright.
6. Refill gas tank.
7. Reconnect spark plug wire.

Belt Cover

Keep area under belt cover free of debris.

1. Remove bolts securing belt cover (Fig. 32) to mower housing. Lift off cover and brush out all debris from belt area. Reinstall belt cover.

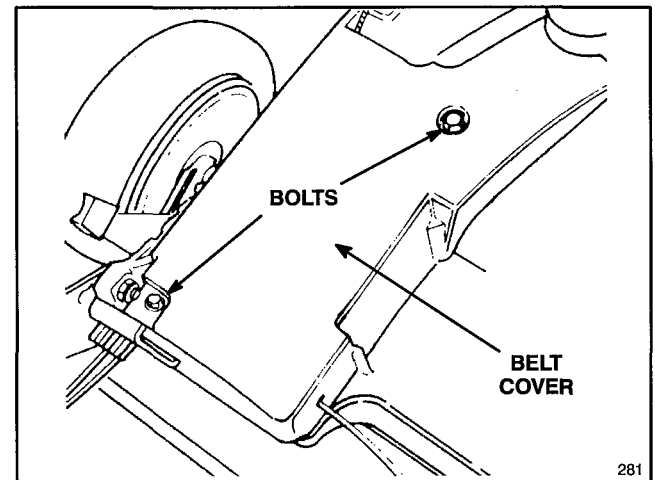

Figure 32

MAINTENANCE

CLEANING BLADE BRAKE CLUTCH SHIELD

The BBC (Blade Brake Clutch) shield should be cleaned periodically, at the end of each mowing season at minimum, to ensure best performance and to prevent parts degradation.

1. Stop engine and pull wire off spark plug (Fig. 18). Remove key from switch on electric start model.
2. Drain gasoline from fuel tank; refer to Draining Gasoline, page 13.
3. Tip mower on its left side (Fig. 33).
4. Remove (2) blade nuts, anti-scalp cup, accelerator, blade, blade spacer, and (3) bolts and washers securing BBC shield to mower deck (Fig. 33).

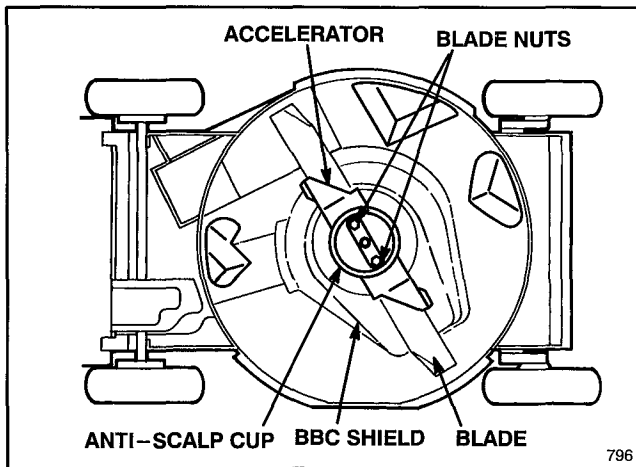

Figure 33

5. Brush or blow debris from inside of shield.
6. Reinstall BBC shield with (3) bolts and washers, blade spacer, blade, blade stiffener, anti-scalp cup, and (2) blade nuts.
7. Reconnect spark plug wire.

PREPARING MOWER FOR STORAGE

1. For long term storage, either drain gasoline from fuel tank or add a fuel stabilizer to the gasoline. To drain gasoline, refer to Draining Gasoline, page 13. After fuel is drained, start engine and let it idle until all fuel is consumed and engine stops. Repeat the starting procedure two more times to assure all gas is removed from the engine. If gasoline is not drained, gum-like varnish deposits will form and cause poor engine operation, even starting problems.

Fuel can be left in gas tank only if a fuel additive, such as Toro's Stabilizer/Conditioner, is added to gasoline and run through engine before storing. Toro's Stabilizer/Conditioner is a petroleum distillate based conditioner/stabilizer. Toro does not recommend stabilizers with an alcohol base, such as ethanol, methanol or isopropyl. Use fuel additive in recommended quantities as specified on container.

Under normal conditions, all fuel additives remain effective in fuel for 6–8 months.

2. Drain oil: refer to Changing Crankcase Oil, page 13. After oil is drained, do not fill crankcase with oil until the following steps (3–11) are completed.
3. Remove spark plug and pour 2 tablespoons of 10W–30 oil into hole in cylinder. Pull starter rope slowly to coat inside of cylinder. Install spark plug and tighten to 14 ft–lb (19 N·m). **DO NOT INSTALL WIRE ON SPARK PLUG.**
4. Clean underside of mower housing: refer to Cleaning Mower Housing, page 16.
5. Check condition of blade: refer to Inspecting/Removing/Sharpening Blade, page 14.
6. Tighten all nuts, bolts, and screws.
7. Clean dirt and chaff from cylinder, cylinder head fins, and blower housing. Also remove grass clippings, dirt, and grime from external parts of the engine, shrouding, and top of mower housing.
8. Clean air cleaner: refer to Servicing Air Cleaner, page 12.
9. Lubricate the wheels: refer to Lubrication, page 15.
10. Charge battery: refer to Charging Battery, page 15.
11. Touch up all rusted or chipped paint surfaces. Toro Re-Kote paint is available from an Authorized TORO Service Dealer.
12. Fill crankcase with oil: refer to Fill Crankcase With Oil, page 13.
13. Store mower in a clean, dry place. Cover mower to keep it clean and protected.

OPTIONAL EQUIPMENT

For special conditions, the following accessories may be purchased at your local Authorized Toro Service Dealer.

1. Dethatcher Kit, Model No. 59131—As spring tines on the Toro Dethatcher (Fig. 34) scratch and vibrate through the grass, thatch is loosened and cut by the mower.

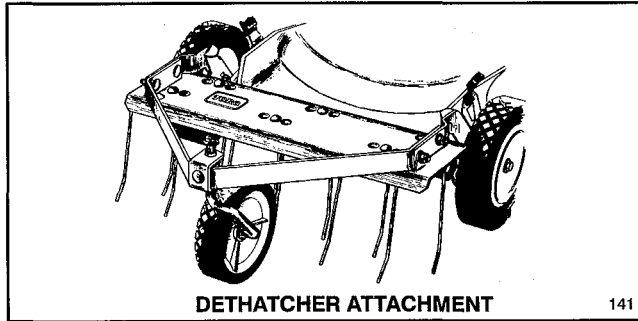

Figure 34

ator is violating state law, Section 4442 Public Resources Code.

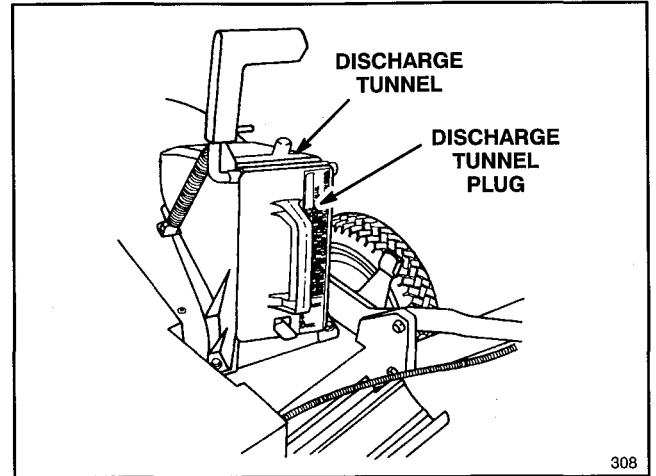

Figure 35

2. Rear Bagging Kit, Model No. 59174—Install discharge tunnel and rear mounting grass bag to convert the Recycler® II Super Pro® mower to a rear bagging mower (Fig. 35). Includes discharge tunnel plug.

3. Side Discharge Kit, Model No. 59189—Install discharge tunnel and rear mounted side discharge chute to convert the Recycler® II Super Pro® mower to a side discharge mower (Fig. 36). Includes discharge tunnel plug.

4. Spark Arrestor, Part No. 77-9040—If a spark arrestor is required because of local, state, or federal regulations, it may be purchased at your local Authorized TORO Service Dealer. If mower is operated on any California forest, brush, or grass covered land without a properly operating spark arrestor, the oper-

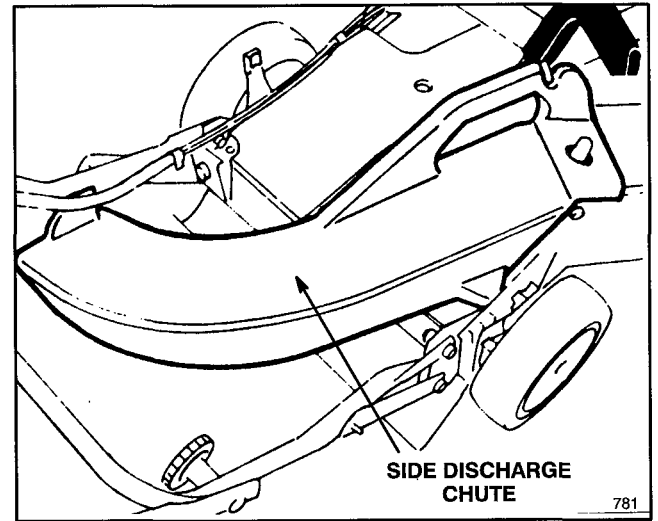

Figure 36

PRODUCT IDENTIFICATION

A model and a serial number decal is located on the underside of the control panel. Always refer to specific numbers on this decal in correspondence or when replacement parts are needed.

TORO SERVICE SUPPORT

If help — concerning safety, set-up, operation, maintenance, or troubleshooting — is ever needed, contact the local Authorized TORO Service Dealer or Distributor. Refer to the “Yellow Pages” for assistance. In addition to skilled service technicians, the dealer and distributor have factory approved accessories and replacement parts. Keep your Toro all TORO. Buy genuine TORO replacement parts and accessories.

It is Toro's policy to design and produce high quality products. To ensure customer satisfaction, Toro has extensive warranty coverage on its products. Your TORO GTS Engine powered product has two warranty statements covering it. The Toro Total Coverage Guarantee is our standard warranty statement and is printed on the last page of this manual.

In addition to The Toro Total Coverage Guarantee, we are so confident that the TORO GTS Engine will provide a high level of performance and durability that we are providing a *Starting Guarantee!* Please read the details of this additional warranty coverage printed below.

THE TORO STARTING GUARANTEE

A Five Year Limited Warranty On All Toro GTS Engines

What Is Covered?

The Toro Company guarantees that your TORO GTS Engine will start on the first or second pull for five years from the date of purchase—if you provide the routine maintenance it requires—or we will fix it. The cost of parts and labor are included, but you must pay transportation costs. This covers TORO GTS rotary mower engines purchased after September 1, 1988, and TORO GTS snow engines (Models 38180 and 38185) purchased after August 31, 1989.

What Must You Do To Keep The Warranty In Effect?

You must maintain your TORO GTS Engine by following the maintenance schedule detailed in the operator's manual, at your expense. You must record this work in the maintenance chart provided in your owner's manual and keep your proof of purchase.

How Do You Get Service?

If the starting performance of your TORO GTS Engine should diminish to the point where it will not start in one or two pulls by a normal, able-bodied adult, you should follow the procedures below:

1. Contact any Authorized TORO Service Dealer, TORO Master Service Dealer, or TORO Distributor (the Yellow Pages of your telephone directory is a good reference source).
2. He will either instruct you to return the product to him or recommend another Authorized TORO Service outlet which might be more convenient.
3. Bring the product, your maintenance records, and proof of purchase to the Service Dealer.

If, for any reason, you are dissatisfied with the Dealer's analysis of your engine's starting condition, or the assistance provided, please feel free to contact us:

TORO Customer Service Department
8111 Lyndale Avenue South
Minneapolis, Minnesota 55420

What Does This Warranty Not Cover?

This Warranty does not cover:

1. Any repairs on products used commercially.
2. Normal maintenance including replacement of spark plugs, air filter, fuel filter, and carburetor adjustments.
3. Oil change and lubrication.
4. Repairs or adjustments due to:
 - a. Failure to follow proper maintenance procedures;
 - b. Rotary mower blade striking an object;
 - c. Contaminants in the fuel system;
 - d. Improper fuel or fuel mixture (consult your owner's manual if in doubt);
 - e. Failure to drain the fuel system prior to any period of non-use over three months;
 - f. Operation misuse, neglect or accidents;
 - g. Repairs or attempted repairs by anyone other than an Authorized TORO Service Dealer.
5. Special operational conditions where starting may require more than two pulls, including:
 - a. First time starts after extended period of non-use or seasonal storage;
 - b. Cool temperature starts such as those found in early spring and late fall may require an additional pull or two (applies to rotary products only);
 - c. Improper starting procedures. If you are having difficulty starting your unit, please check the operator's manual to ensure you are using the correct starting procedures. This can save an unnecessary visit to a Service Dealer.

All warranty repairs reimbursable under this warranty must be performed by an Authorized TORO Service Dealer using Toro approved replacement parts.

The above remedy through repair by an Authorized TORO Service Dealer is the purchaser's sole remedy.

How Does State Law Relate To This Warranty?

There is no other express warranty except for The Toro Promise. All implied warranties of merchantability (that the product is fit for ordinary use) and fitness for use (that the product is fit for a particular purpose) are limited to the duration of the express warranty.

Some states do not allow limitation on how long implied warranties last, so the above exclusion may not apply to you.

The Toro Company is not liable for indirect, incidental or consequential damages in connection with the use of the product, including any cost or expense of providing substitute equipment or service during periods of malfunction or non-use.

Some states do not allow exclusions of incidental or consequential damages, so the above exclusion may not apply to you.

This warranty gives you specific legal rights, and you may also have other rights which vary from state to state.

GUARANTEED TO START MAINTENANCE RECORD

To keep the starting guarantee in effect, you must perform the following maintenance after every 25 operating hours, more often in dusty and dirty conditions. Follow the procedures in this Operator's Manual and record information on this chart.

Date	Hours Used	Air Cleaner Service	Change Oil <small>Doesn't Apply to 2-Cycle</small>	Lubricate Wheels	Check Spark Plug	Mower Storage

GUARANTEED TO START MAINTENANCE RECORD

Date	Hours Used	Air Cleaner Service	Change Oil Doesn't Apply to 2-Cycle	Lubricate Wheels	Check Spark Plug	Mower Storage





Consumer Products

THE TORO TOTAL COVERAGE GUARANTEE A Full Two-Year Warranty (Limited Warranty for Commercial Use)

What Is Covered By This Express Warranty?

The Toro Company promises to repair any TORO Product used for residential purposes if defective in materials or workmanship for a period of two years from the date of purchase. The cost of parts and labor are included, but the customer pays the transportation costs.

Transportation within a 15 mile radius of the servicing dealer is covered under this warranty for two-stage snowthrowers, walk behind debris equipment and all TORO Wheel Horse riding products. Walk power mowers, single stage snowthrowers, and other products not specifically covered, are excluded from the transportation coverage provided by this warranty.

What Products Are Covered By This Warranty?

This warranty applies to all gasoline powered Consumer Products (including TORO Wheel Horse riding products). ProLine riding products, wide area walk behind mowers and 21" Commercial mowers without blade stop controls are covered by separate warranty statements.

How About Commercial Use?

TORO Consumer Products used for commercial, institutional or rental use are covered by a limited warranty for the following time periods from the date of purchase:

Products	Warranty Period
• Garden Tractors	
Chassis	1 year limited warranty
Engine	2 year limited warranty
• 21" Commercial Duty Walk Mower with blade stop controls	1 year limited warranty
• Lawn Tractors, Yard Tractors, Rear Engine Riders, 3.0 and 3.5 HP Edgers, Straight Shaft Trimmers, and Backpack Blowers	90 day limited warranty
• All Others	45 day limited warranty

How Do You Get Warranty Service?

Should you feel your TORO product contains a defect in material or workmanship, contact the dealer who sold you the product or any Authorized TORO Service Dealer or TORO Master Service Dealer. The Yellow Pages of your telephone directory is a good reference source. The dealer will either arrange service at his/her dealership or recommend another Authorized Service Dealer who may be more convenient. You may need proof of purchase (copy of registration card, sales receipt, etc.) for warranty validation.

If for any reason you are dissatisfied with the Service Dealer's analysis of the defect in materials or workmanship or if you need a referral to a TORO Service Dealer, please feel free to contact us at the following address:

Toro Customer Service Department
8111 Lyndale Avenue South
Bloomington, MN 55420-1196
612-888-8801

What Must You Do To Keep The Warranty In Effect?

You must maintain your TORO Product by following the maintenance procedures described in the operator's manual. Such routine maintenance, whether performed by a dealer or by you, is at your expense.

What Does This Warranty Not Cover? and

How Does Your State Law Relate To This Warranty?

There is no other express warranty except the TORO Starting Guarantee on GTS Engines. This express warranty does not cover:

- Cost of regular maintenance service or parts, such as filters, fuel, lubricants, tune-up parts, blade sharpening, brake and clutch adjustments.
- Any product or part which has been altered or misused or required replacement or repair due to normal wear, accidents, or lack of proper maintenance.
- Repairs necessary due to improper fuel, contaminants in the fuel system, or failure to properly prepare the fuel system prior to any period of non-use over three months.
- Pickup and delivery charges for distances beyond a 15 mile radius from an Authorized TORO Service Dealer (covered products only).

All repairs covered by this warranty must be performed by an Authorized TORO Service Dealer using Toro approved replacement parts.

Repair by an Authorized TORO Service Dealer is your sole remedy under this warranty.

The Toro Company is not liable for indirect, incidental or consequential damages in connection with the use of the TORO Products covered by this warranty, including any cost or expense of providing substitute equipment or service during reasonable periods of malfunction or non-use pending completion of repairs under this warranty. Some states do not allow exclusions of incidental or consequential damages, so the above exclusion may not apply to you.

This warranty gives you specific legal rights, and you may also have other rights which vary from state to state.

COUNTRIES OTHER THAN THE UNITED STATES OR CANADA

Customers who have purchased TORO products exported from the United States or Canada should contact their TORO Distributor (Dealer) to obtain guarantee policies for your country, province, or state. If for any reason you are dissatisfied with your Distributor's service or have difficulty obtaining guarantee information, contact the TORO importer. If all other remedies fail, you may contact us at The Toro Company.