



Count on it.

Parts Catalog

**21in 60V
Lawn Mower**

Model No. 21611T—Serial No. 400000000 and Up



Ordering Replacement Parts

To order replacement parts, please supply the part number, the quantity, and the description of each part desired.

Understanding Reference Numbers

Each identified part in an illustration has a reference number. The reference number for a part also appears in the parts list, along with other information about the part.

This catalog uses two special reference number formats, one to indicate parts in a service assembly and another to indicate the quantity of a given part in an illustration.

Service Assembly Reference Numbers

Parts in service assemblies have reference numbers in the form a:b. The a represents the reference number of the entire service assembly and the b represents a sequential number unique to each part within the service assembly.

For example, a wheel assembly might be identified by reference number 6, the tire by 6:1, the valve by 6:2, and the wheel by 6:3. When you order the assembly identified by reference number 6, you receive all parts identified by reference numbers 6:1, 6:2, and 6:3. However, you may also order any part individually. Reference numbers of this type appear in illustration and in parts lists.

Reference Numbers Indicating Quantity

In an illustration, if a reference number indicates more than one part, the reference number has the form nX y. The n represents the quantity of the part, the X is the multiplication symbol, and the y represents the reference number.

For example, in an illustration, the reference number 2X 37 means that two of the parts identified by reference number 37 are indicated.

Contents

Deck Assembly	4
Decal Assembly	6
Shroud Assembly	8
Motor Module and Blade Assembly	10
Motor Module Assembly No. 145-5873	12
Front Wheel and Height-of-Cut Assembly	14
Rear Wheel and Height-of-Cut Assembly	16
Handle Assembly	18
Attachments and Accessories	20

Deck Assembly

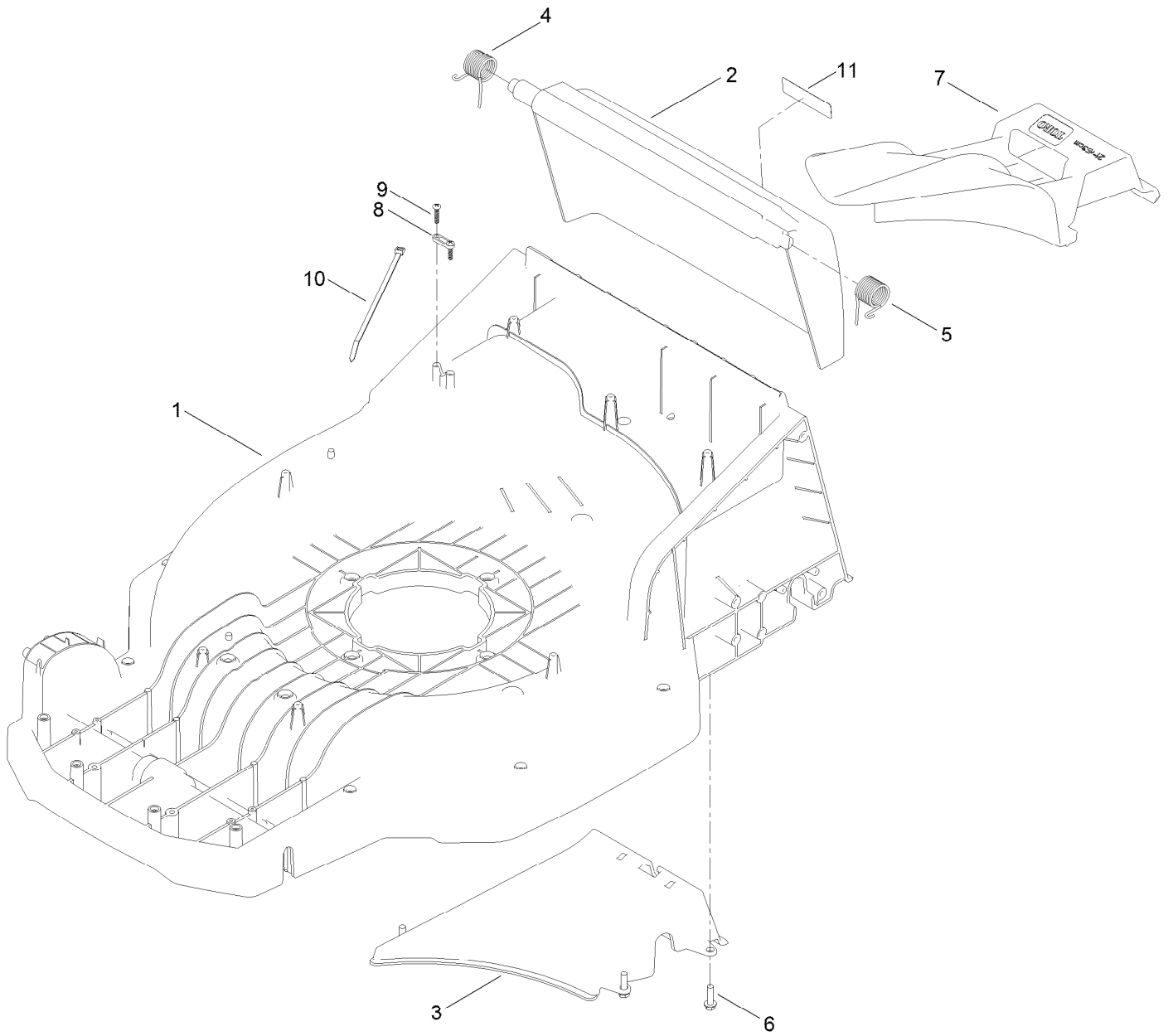

Deck Assembly (continued)

<i>Ref.</i>	<i>Part Number</i>	<i>Qty.</i>	<i>Description</i>	<i>Ref.</i>	<i>Part Number</i>	<i>Qty.</i>	<i>Description</i>
1	145-5665	1	Deck-Plastic, 21"	7	145-5667	1	Plug-Discharge
2	140-2396	1	ASM-Rear Door, In-Mold (60V)	8	119-3814	1	Clamp-Harness
3	145-5666	1	Ramp-Discharge	9	94-4496	2	Screw-PPH
4	139-5479	1	Spring-Torsion, RH	10	614249	1	Tie-Cable
5	139-5478	1	Spring-Torsion, LH	11	133-8054	1	Decal-Prop 65, Short, Trilingual
6	46-8091	4	Screw-HWH				

Decal Assembly

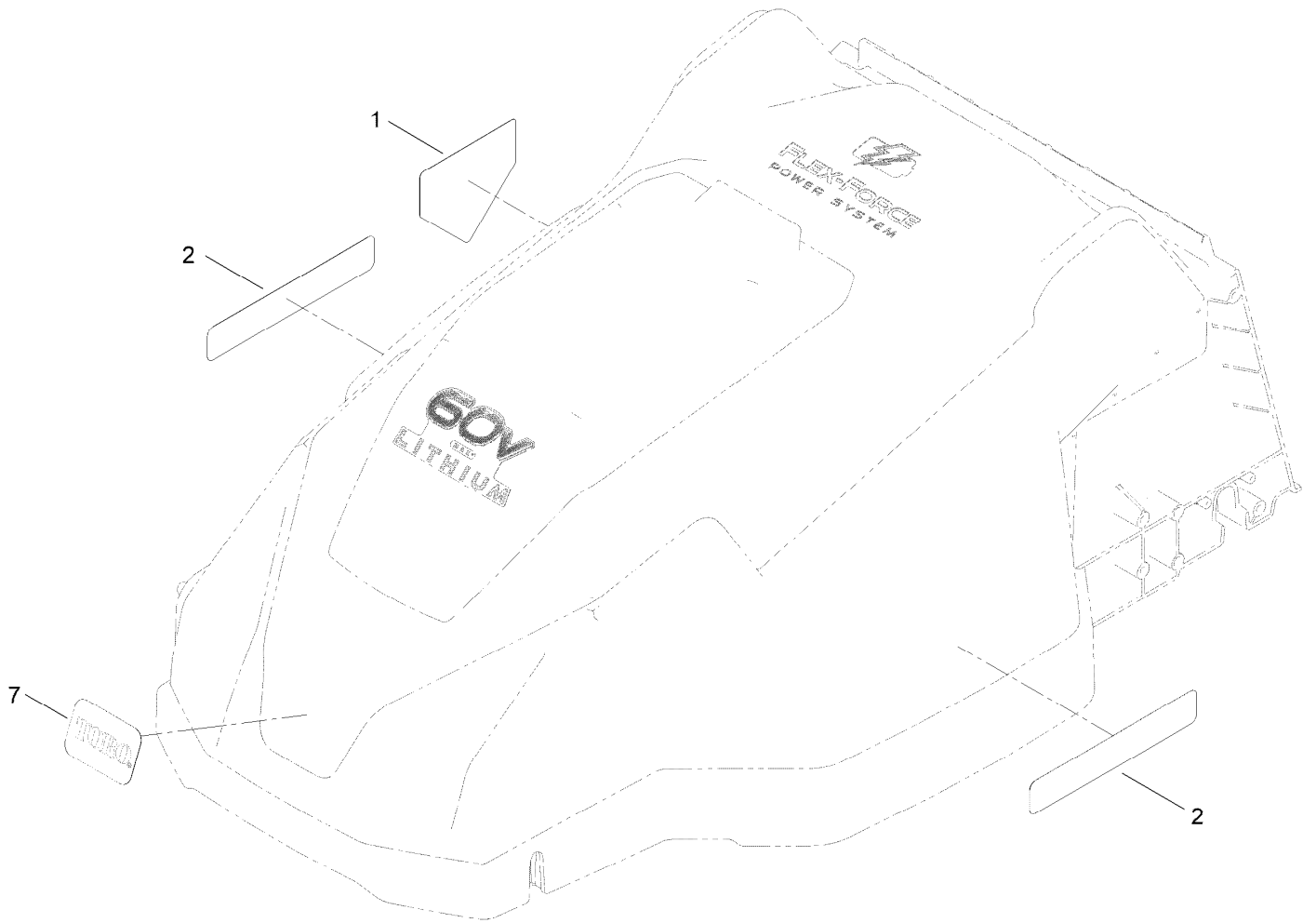

Decal Assembly (continued)

<i>Ref.</i>	<i>Part Number</i>	<i>Qty.</i>	<i>Description</i>
1	94-8072	1	Decal-Danger
2	147-4214	2	Decal-Deck
7	147-4209	1	Decal-Toro, Silver (2.75 X 1.8)

Shroud Assembly

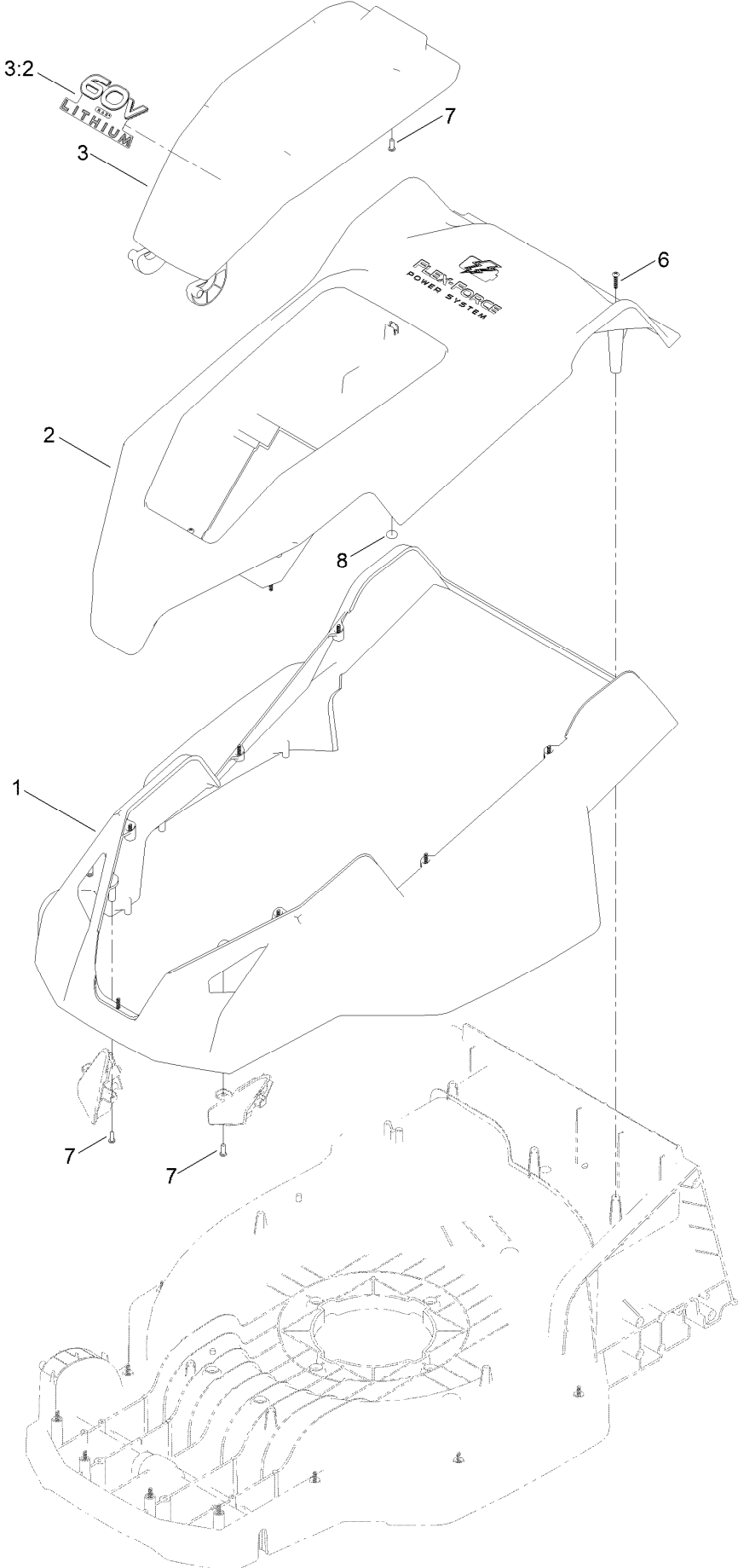

Shroud Assembly (continued)

<i>Ref.</i>	<i>Part Number</i>	<i>Qty.</i>	<i>Description</i>	<i>Ref.</i>	<i>Part Number</i>	<i>Qty.</i>	<i>Description</i>
1	145-5673	1	Shroud-Bottom, No LED	6	94-4496	22	Screw-PPH
2	145-5669	1	Shroud-Top	7	94-6961	1	Screw
3	147-4239	1	ASM-Cover, Battery	8	145-5696	1	Magnet-Cover
3:2	147-4208	1	Decal-60V, Lithium				

Motor Module and Blade Assembly

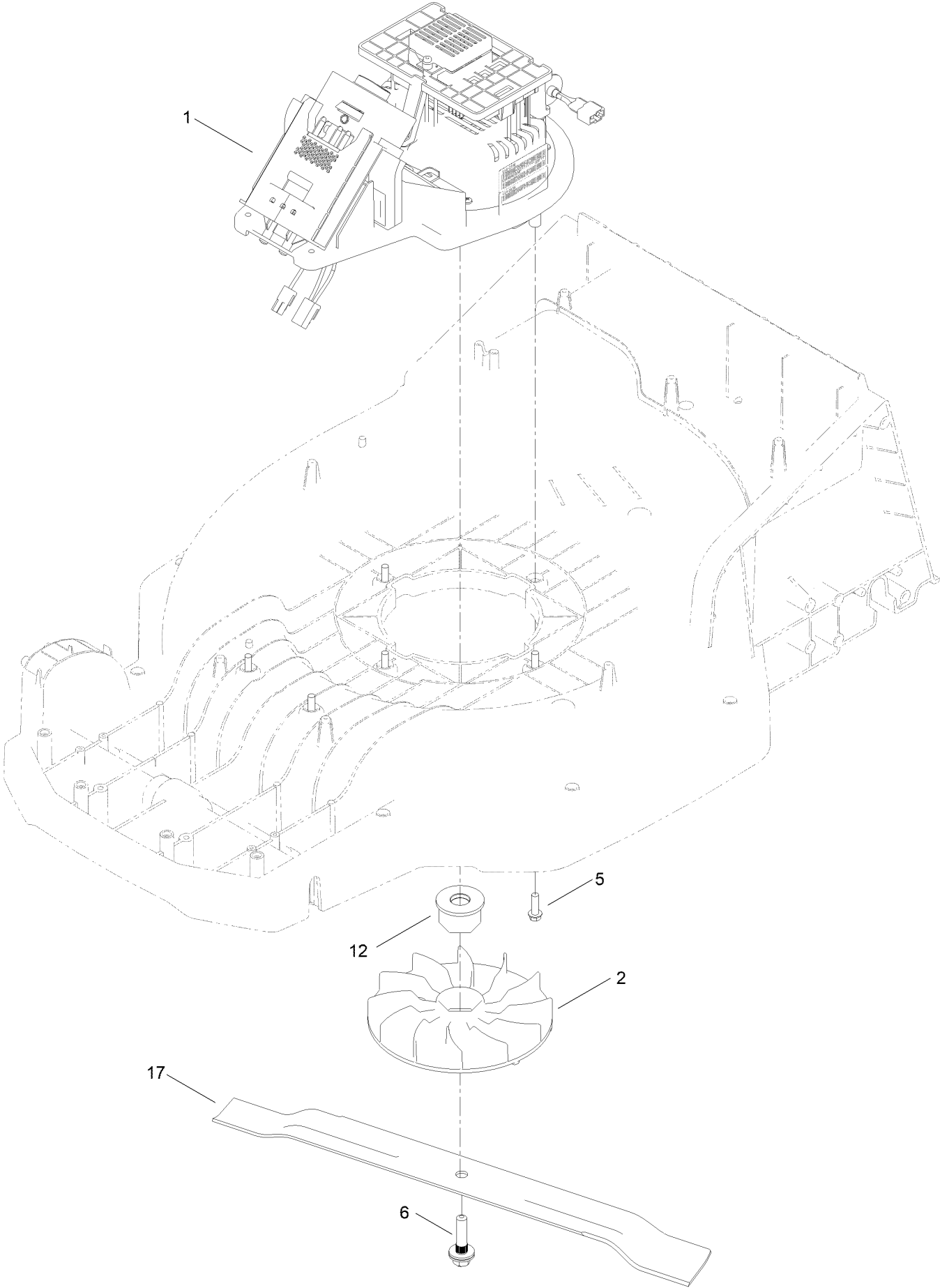

Motor Module and Blade Assembly (continued)

<i>Ref.</i>	<i>Part Number</i>	<i>Qty.</i>	<i>Description</i>	<i>Ref.</i>	<i>Part Number</i>	<i>Qty.</i>	<i>Description</i>
1	145-5873	1	ASM-Power, Cobra HP	6	145-5695	1	Bolt-Blade, Sems
2	145-5681	1	Fan-Motor	12	144-6527	1	Insert-Fan, Motor
5	46-8091	6	Screw-HWH	17	145-5684-03	1	Blade-20.25"

Motor Module Assembly No. 145-5873

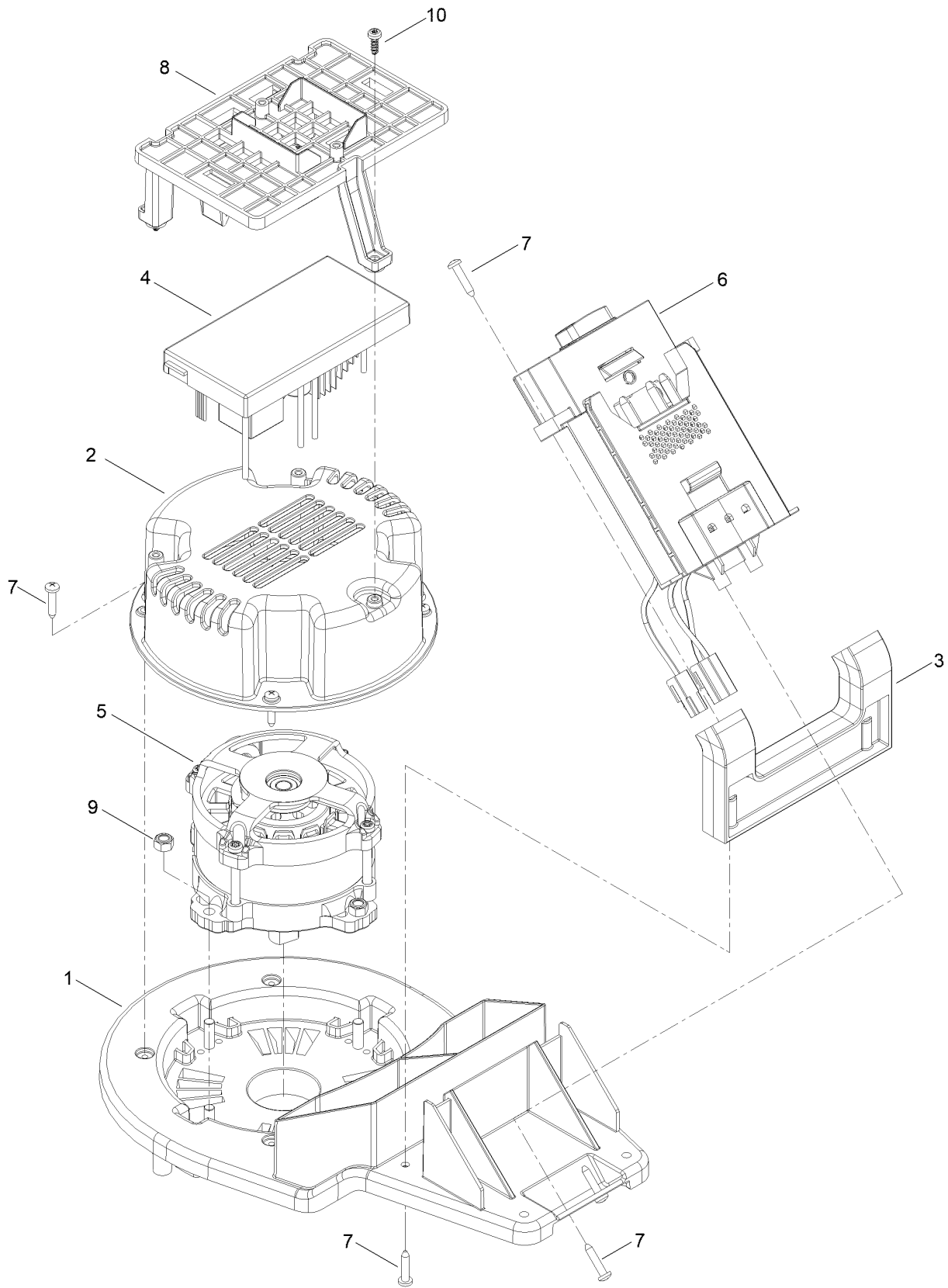

Motor Module Assembly No. 145-5873 (continued)

<i>Ref.</i>	<i>Part Number</i>	<i>Qty.</i>	<i>Description</i>	<i>Ref.</i>	<i>Part Number</i>	<i>Qty.</i>	<i>Description</i>
1	144-6511	1	ASM-Mount, Motor	6	137-9404	1	Battery Track ASM
2	144-6487	1	Cover-Motor	7	145-5628	10	Screw-PPH, ST4.2X20
3	144-6489	1	Support-Receiver	8	147-4215	1	Brkt-Controller
4	147-4218	1	Controller-Motor, HP	9	145-5617	4	Nut-Hex, M6
5	144-6491	1	Motor-1Kw, 60V	10	145-5627	3	Screw-Tph, ST4.2X12

Front Wheel and Height-of-Cut Assembly

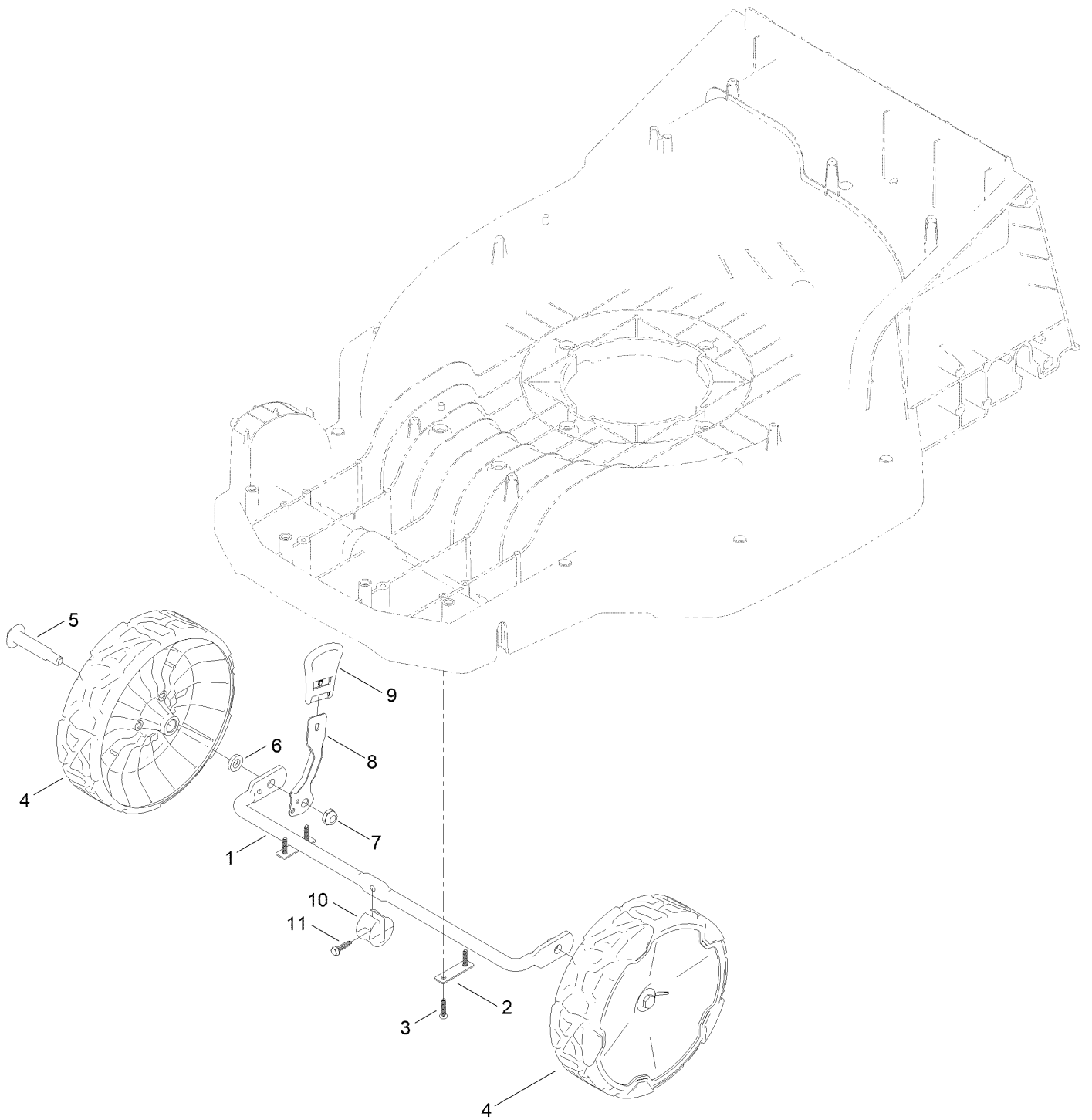

Front Wheel and Height-of-Cut Assembly (continued)

<i>Ref.</i>	<i>Part Number</i>	<i>Qty.</i>	<i>Description</i>	<i>Ref.</i>	<i>Part Number</i>	<i>Qty.</i>	<i>Description</i>
1	144-6495-03	1	Axle-Front	7	121-4600	2	Nut-Hex
2	144-6496	2	Strap-Axle	8	133-8154	1	Arm-Spring
3	94-4496	4	Screw-PPH	9	110-0549	1	Knob-HOC
4	140-2355	2	ASM-8" Wheel, Idler	10	127-6800	1	Stop-Axle
5	92-1057	2	Bolt-Shoulder	11	127-6831	1	Screw-HWH
6	139-5449	2	Washer-Wheel Bolt				

Rear Wheel and Height-of-Cut Assembly

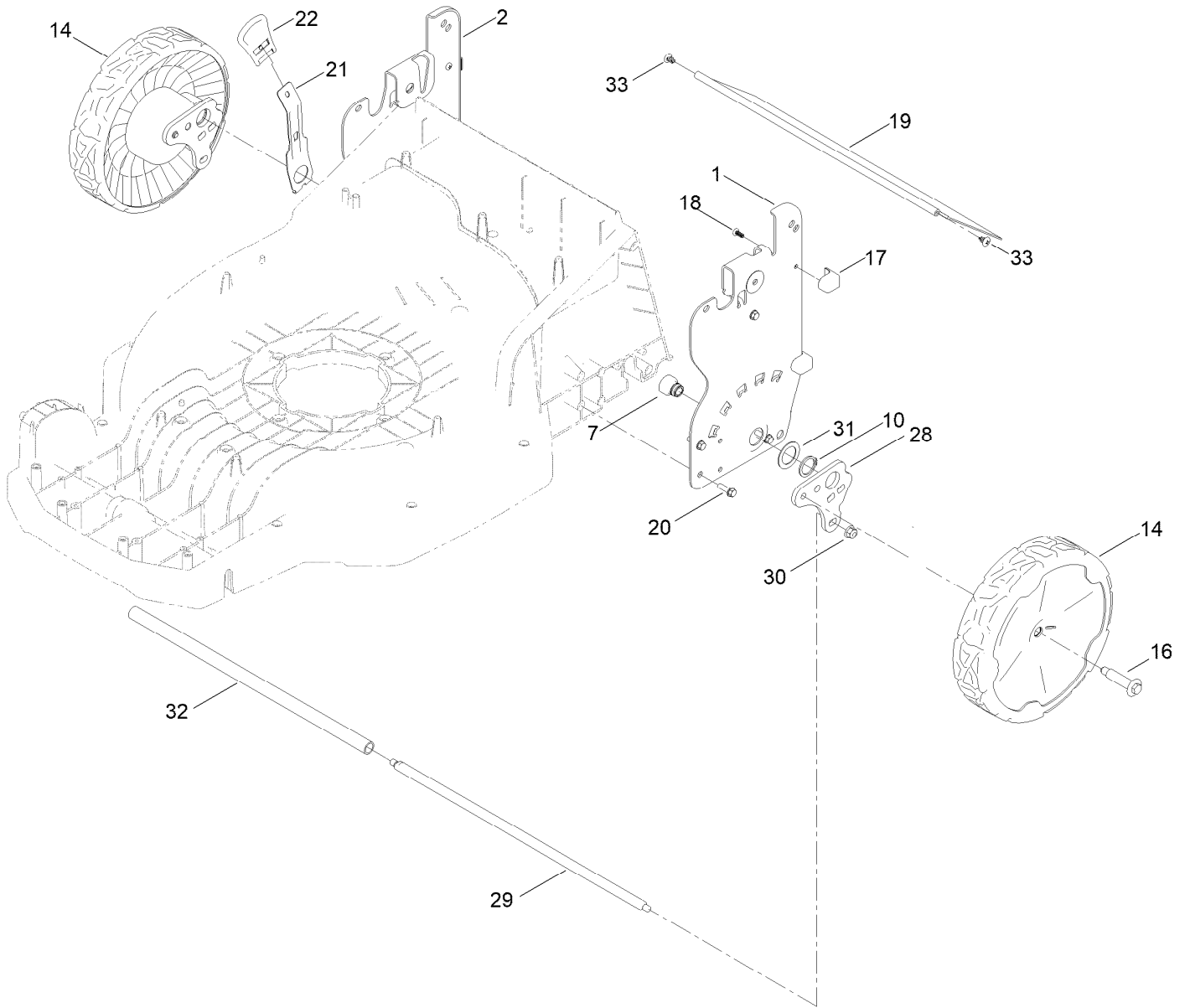

Rear Wheel and Height-of-Cut Assembly (continued)

<i>Ref.</i>	<i>Part Number</i>	<i>Qty.</i>	<i>Description</i>	<i>Ref.</i>	<i>Part Number</i>	<i>Qty.</i>	<i>Description</i>
1	144-6542-05	1	Plate-HOC, LH	20	46-8091	8	Screw-HWH
2	144-6541-05	1	Plate-HOC, RH	21	144-6530	1	Arm-Spring
7	131-0836	2	Retainer-Bearing, HOC	22	110-0549	1	Knob-HOC
10	32151-36	2	Ring-Retaining	28	145-5678	2	Brkt-Pivot, Rear
14	140-2351	2	ASM-9.65" Wheel, Bushings	29	144-6513	1	Rod-Connecting, Rear
16	145-3899	2	Wheel Bolt	30	104-8300	2	Nut-HF, NI
17	140-2369	4	Pad-Smart Stow	31	3256-42	1	Washer-Flat
18	107-7461	4	Screw-Plastite	32	145-5679	1	Roller-Striper
19	144-6543	1	Shield-Trailing	33	139-1692	2	Screw-Thd

Handle Assembly

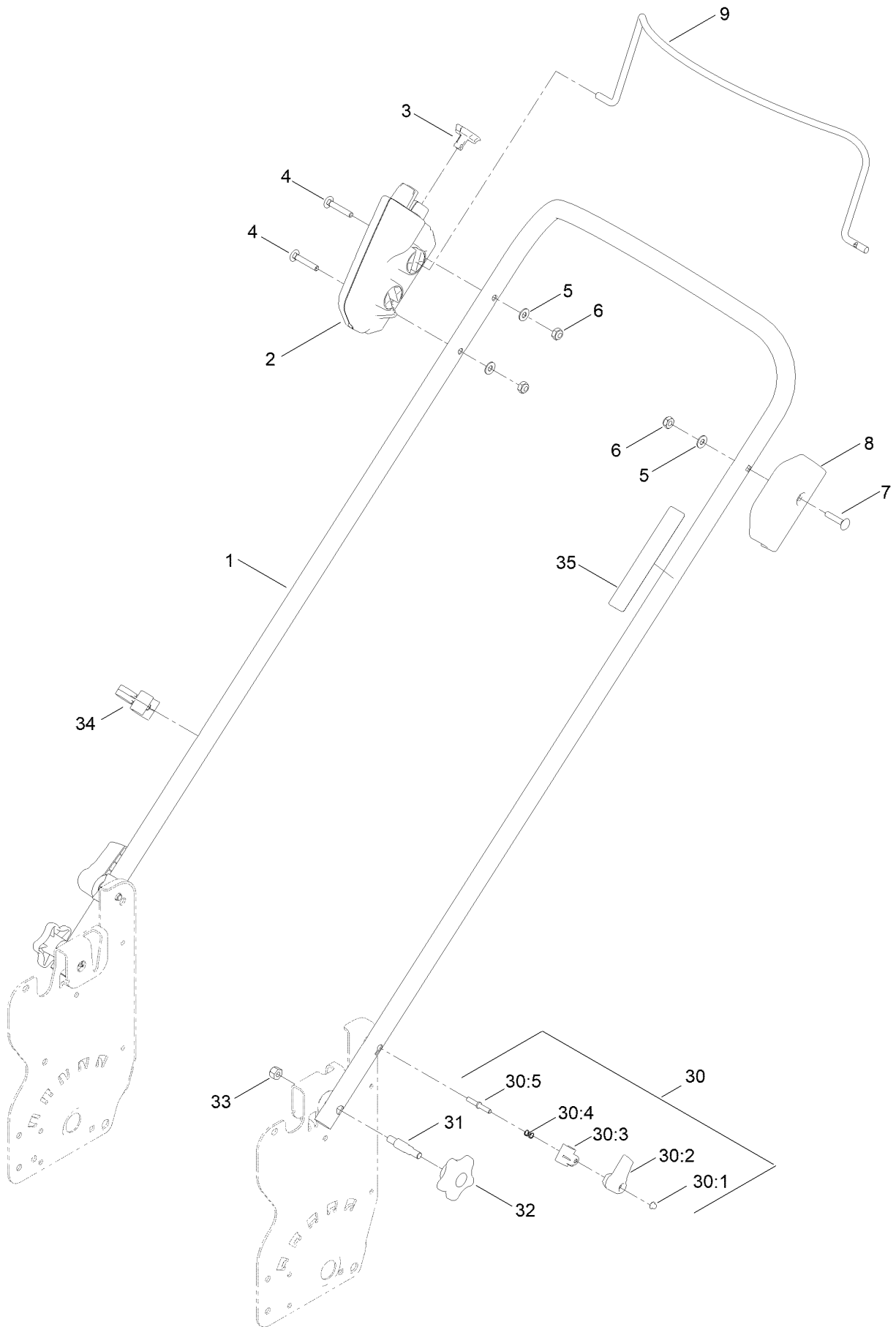

Handle Assembly (continued)

<i>Ref.</i>	<i>Part Number</i>	<i>Qty.</i>	<i>Description</i>	<i>Ref.</i>	<i>Part Number</i>	<i>Qty.</i>	<i>Description</i>
1	144-6534-05	1	Handle-Mower, Electric	30:1	140-4157	1	Nut-Push
2	145-5660	1	ASM-Control, 1 Bail	30:2	138-3248	1	Lever-Release
3	145-5624	1	Key-Bail	30:3	138-3253	1	Anchor-Spring
4	108-0988	2	Screw-CARR	30:4	115-2858	1	Spring-Compression
5	3256-1	3	Washer-Flat	30:5	140-4158	1	Rod-Release
6	139-1724	3	Nut-Lock	31	139-6588	2	Bolt-Shoulder, Handle
7	3229-3	1	Screw-CARR	32	117-5976	2	Knob-Handle
8	147-4212	1	Base-Pivot	33	3296-29	2	Nut-Lock, NI
9	147-4205-03	1	Bail-Blade	34	114-7988	1	Guide-Cable
30	138-3249	2	Quick Release ASM	35	144-3175	1	Decal-Controls (60V Start)

Attachments and Accessories

For 21611T 21in 60V Lawn Mower

Product Name	Model/Part
ASM-Chute, SD	147-8696
Lawnmower Cover.....	490-7462
Smart Stow Walk Power Mower Cover	490-2012
Lawn Striping Kit with 22in Roller.....	20601
Bag-Walk Behind (Toro).....	490-7318
60V LI-ION, Battery 4.0 AH	88640
60V LI-ION Battery 5.0 AH.....	88650
60V LI-ION Battery 6.0 AH.....	88660
60V LI-ION Battery 7.5 AH.....	88675
60V Battery Charger 1 AMP	88610
60V Battery Charger 2 AMP	88602
60V Rapid Battery Charger 5.4 AMP	88605
60V Cordless Blower (Bare Tool).....	51820T
60V Cordless Trimmer (Bare Tool).....	51830T
60v 24in Max Hedge Trimmer (Bare Tool).....	51840T
16in 60V Max Chainsaw (Bare Tool).....	51850T
Power Clear 21in 60V Cordless (Bare Tool).....	39901T

Notes:

Notes:

Notes:



Count on it.