



## **Z149 and Z153**

### **Z Master<sup>®</sup> with 52" SFS Side Discharge Mower**

Model No. 74179—Serial No. 220000001 and Up

Model No. 74198—Serial No. 220000001 and Up

**Operator's Manual**



## Warning



**The engine exhaust from this product contains chemicals known to the State of California to cause cancer, birth defects, or other reproductive harm.**

Because in some areas there are local, state, or federal regulations requiring that a spark arrester be used on the engine of this mower, a spark arrester is incorporated with the muffler assembly.

**Important** This engine is equipped with a spark arrester muffler. It is a violation of California Public Resource Code Section 4442 to use or operate this engine without a spark arrester muffler on any forest-covered, brush-covered or grass-covered land. Other states or federal areas may have similar laws.

This spark ignition system complies with Canadian ICES-002.

Ce système d'allumage par étincelle de véhicule est conforme à la norme NMB-002 du Canada.

**The enclosed Engine Owner's Manual is supplied for information regarding The U.S. Environmental Protection Agency (EPA) and the California Emission Control Regulation of emission systems, maintenance and warranty.**

**Keep this engine Owner's Manual with your unit. Should this engine Owner's Manual become damaged or illegible, replace immediately. Replacements may be ordered through the engine manufacturer.**

# Contents

	Page
Introduction .....	3
Safety .....	3
Safe Operating Practices .....	3
Toro Mower Safety .....	5
Slope Chart .....	7
Safety and Instruction Decals .....	9
Gasoline and Oil .....	13
Recommended Gasoline .....	13
Using Stabilizer/Conditioner .....	13
Filling the Fuel Tank .....	13
Checking the Engine Oil Level .....	13
Setup .....	14
Loose Parts .....	14
Installing the Drive Wheels .....	14
Checking the Tire Pressure .....	14
Installing the Seat Retaining Rod .....	15
Installing the Motion Control Levers .....	15

	Page
Activating the Battery .....	16
Checking the Hydraulic Fluid .....	16
Greasing the Bearings .....	16
Checking the Leveling of the Mower Deck .....	17
Checking the Side Discharge Chute .....	17
Checking the Engine Oil Level .....	17
Operation .....	17
Think Safety First .....	17
Controls .....	17
Operating the Parking Brake .....	18
Starting and Stopping the Engine .....	18
Operating the Power Take Off (PTO) .....	19
The Safety Interlock System .....	19
Driving Forward or Backward .....	20
Stopping the Machine .....	21
Adjusting the Height-of-Cut .....	21
Adjusting the Anti-Scalp Rollers .....	21
Positioning the Seat .....	22
Pushing the Machine by Hand .....	23
Operating with Side Discharge .....	23
Using a Rollover Protection System .....	23
Transporting the Machine .....	24
Loading the Machine .....	24
Tips for Mowing Grass .....	24
Maintenance .....	26
Recommended Maintenance Schedule .....	26
Servicing the Cutting Blades .....	27
Cleaning the Cooling System .....	29
Servicing the Air Cleaner .....	29
Servicing the Engine Oil .....	30
Servicing the Spark Plug .....	32
Replacing the Fuel Filter .....	33
Draining the Fuel Tank .....	33
Servicing the Spark Arrester .....	33
Greasing and Lubrication .....	34
Checking the Tire Pressure .....	35
Servicing the Hydraulic System .....	35
Adjusting the Motion Controls .....	37
Adjusting the Castor Pivot Bearing .....	38
Checking the Wheel Hub Slotted Nut .....	39
Adjusting the Mower Level .....	39
Adjusting the Push Arms .....	40
Cleaning Under the Deck .....	40
Inspecting the Belts .....	40
Replacing the Deck Belt .....	40
Replacing the Pump Drive Belt .....	41
Adjusting the Parking Brake .....	42
Servicing the Fuses .....	42
Servicing the Battery .....	43

	Page
Replacing the Grass Deflector .....	45
Waste Disposal .....	46
Mercury Tilt Switch .....	46
Mercury Tilt Switch Disposal .....	46
Wiring Diagram .....	47
Cleaning and Storage .....	48
Troubleshooting .....	49
The Toro Total Coverage Guarantee .....	52

## Introduction

Read this manual carefully to learn how to operate and maintain your product properly. The information in this manual can help you and others avoid injury and product damage. Although Toro designs and produces safe products, you are responsible for operating the product properly and safely.

Whenever you need service, genuine Toro parts, or additional information, contact an Authorized Service Dealer or Toro Customer Service and have the model and serial numbers of your product ready. Figure 1 illustrates the location of the model and serial numbers on the product.

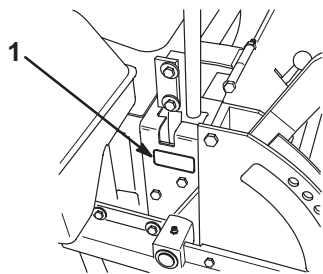

m-3648

**Figure 1**

1. Location of the model and serial numbers

Write the product model and serial numbers in the space below:

<p><b>Model No.</b> _____</p> <p><b>Serial No.</b> _____</p>
--

This manual identifies potential hazards and has special safety messages that help you and others avoid personal injury and even death. **Danger**, **Warning**, and **Caution** are signal words used to identify the level of hazard. However, regardless of the hazard, be extremely careful.

**Danger** signals an extreme hazard that *will* cause serious injury or death if you do not follow the recommended precautions.

**Warning** signals a hazard that *may* cause serious injury or death if you do not follow the recommended precautions.

**Caution** signals a hazard that may cause minor or moderate injury if you do not follow the recommended precautions.

This manual uses two other words to highlight information.

**Important** calls attention to special mechanical information and **Note**: emphasizes general information worthy of special attention.

## Safety

**This machine meets or exceeds the B71.4 1999 specifications of the American National Standards Institute, in effect at time of production.**

**Note:** The addition of attachments made by other manufacturers that do not meet American National Standards Institute certification will cause noncompliance of this machine.

**Improper use or maintenance by the operator or owner can result in injury. To reduce the potential for injury, comply with these safety instructions and always pay attention to the safety alert ▲ symbol, which means CAUTION, WARNING, or DANGER—“personal safety instruction.” Failure to comply with the instruction may result in personal injury or death.**

## Safe Operating Practices

The following instructions are from ANSI standard B71.4—1999.

### Training

- Read the Operator’s Manual and other training material. If the operator(s) or mechanic(s) can not read English it is the owner’s responsibility to explain this material to them.
- Become familiar with the safe operation of the equipment, operator controls, and safety signs.
- All operators and mechanics should be trained. The owner is responsible for training the users.
- Never let children or untrained people operate or service the equipment. Local regulations may restrict the age of the operator.
- The owner/user can prevent and is responsible for accidents or injuries occurring to himself or herself, other people or property.

## Preparation

- Evaluate the terrain to determine what accessories and attachments are needed to properly and safely perform the job. Only use accessories and attachments approved by the manufacturer.
- Wear appropriate clothing including hard hat, safety glasses and ear protection. Long hair, loose clothing or jewelry may get tangled in moving parts.
- Inspect the area where the equipment is to be used and remove all objects such as rocks, toys and wire which can be thrown by the machine.
- Use extra care when handling gasoline and other fuels. They are flammable and vapors are explosive.
  - Use only an approved container
  - Never remove gas cap or add fuel with engine running. Allow engine to cool before refueling. Do not smoke.
  - Never refuel or drain the machine indoors.
- Check that operator's presence controls, safety switches and shields are attached and functioning properly. Do not operate unless they are functioning properly.

## Operation

- Never run an engine in an enclosed area.
- Only operate in good light, keeping away from holes and hidden hazards.
- Be sure all drives are in neutral and parking brake is engaged before starting engine. Only start engine from the operator's position. Use seat belts if provided.
- Slow down and use extra care on hillsides. Be sure to travel in the recommended direction on hillsides. Turf conditions can affect the machine's stability. Use caution while operating near drop-offs.
- Slow down and use caution when making turns and when changing directions on slopes.
- Never raise deck with the blades running.
- Never operate with the PTO shield, or other guards not securely in place. Be sure all interlocks are attached, adjusted properly, and functioning property.
- Never operate with the discharge deflector raised, removed or altered, unless using a grass catcher.
- Do not change the engine governor setting or overspeed the engine.
- Stop on level ground, lower implements, disengage drives, engage parking brake (if provided), shut off engine before leaving the operator's position for any reason including emptying the catchers or unclogging the chute.

- Stop equipment and inspect blades after striking objects or if an abnormal vibration occurs. Make necessary repairs before resuming operations.
- Keep hands and feet away from the cutting units.
- Look behind and down before backing up to be sure of a clear path.
- Never carry passengers and keep pets and bystanders away.
- Slow down and use caution when making turns and crossing roads and sidewalks. Stop blades if not mowing.
- Be aware of the mower discharge direction and do not point it at anyone.
- Do not operate the mower under the influence of alcohol or drugs
- Use care when loading or unloading the machine into a trailer or truck
- Use care when approaching blind corners, shrubs, trees, or other objects that may obscure vision.

## Maintenance and storage

- Disengage drives, lower implement, set parking brake, stop engine and remove key or disconnect spark plug wire. Wait for all movement to stop before adjusting, cleaning or repairing.
- Clean grass and debris from cutting units, drives, mufflers, and engine to help prevent fires. Clean up oil or fuel spillage.
- Let engine cool before storing and do not store near flame.
- Shut off fuel while storing or transporting. Do not store fuel near flames or drain indoors.
- Park machine on level ground. Never allow untrained personnel to service machine.
- Use jack stands to support components when required.
- Carefully release pressure from components with stored energy.
- Disconnect battery or remove spark plug wire before making any repairs. Disconnect the negative terminal first and the positive last. Reconnect positive first and negative last.
- Use care when checking blades. Wrap the blade(s) or wear gloves, and use caution when servicing them. Only replace blades. Never straighten or weld them.
- Keep hands and feet away from moving parts. If possible, do not make adjustments with the engine running.

- Charge batteries in an open well ventilated area, away from spark and flames. Unplug charger before connecting or disconnecting from battery. Wear protective clothing and use insulated tools.
- Keep all parts in good working condition and all hardware tightened. Replace all worn or damaged decals.

## Toro Mower Safety

The following list contains safety information specific to Toro products or other safety information that you must know that is not included in the ANSI standards.

This product is capable of amputating hands and feet and throwing objects. Always follow all safety instructions to avoid serious injury or death.

This product is designed for cutting and recycling grass or, when equipped with a grass bagger, for catching cut grass. Any use for purposes other than these could prove dangerous to user and bystanders.

### General Operation

- Allow only responsible adults who are familiar with the instructions to operate the machine.
- Be sure the area is clear of other people before mowing. Stop the machine if anyone enters the area.
- Do not mow in reverse unless absolutely necessary. Always look down and behind before and while backing.
- Be aware of the mower discharge direction and do not point it at anyone. Do not operate the mower without either the entire grass catcher or the guard in place.
- Slow down before turning. Sharp turns on any terrain may cause loss of control.
- Turn off blades when not mowing.
- Keep hands, feet, hair and loose clothing away from attachment discharge area, underside of mower and any moving parts while engine is running.
- Stop the engine before removing the grass catcher or unclogging the chute.
- Mow only in daylight or good artificial light.
- Watch for traffic when operating near or crossing roadways.
- Do not touch equipment or attachment parts which may be hot from operation. Allow to cool before attempting to maintain, adjust or service.

- Before operating a machine with ROPS (roll over protection) be certain the seat belts are attached to prevent the seat from pivoting forward.
- Use only Toro-approved attachments. Warranty may be voided if used with unapproved attachments.

### Slope Operation

Slopes and ramps are a major factor related to loss-of-control and tip-over accidents, which can result in severe injury or death. All slopes and ramps require extra caution. If you cannot back up the slope or if you feel uneasy on it, do not mow it.

#### DO

- If a steep slope must be ascended, back up the hill, and drive forward down the hill, keeping the machine in gear.
- Remove obstacles such as rocks, tree limbs, etc. from the mowing area. Watch for holes, ruts or bumps, as uneven terrain could overturn the machine. Tall grass can hide obstacles.
- Use slow speed so that you will not have to stop while on the slope.
- Follow the manufacturer's recommendations for wheel weights or counterweights to improve stability.
- Use extra care with grass catchers or other attachments. These can change the stability of the machine.
- Keep all movement on slopes slow and gradual. Do not make sudden changes in speed or direction.
- Avoid starting or stopping on a slope. If tires lose traction, disengage the blades and proceed slowly straight down the slope.
- When operating machine on slopes, banks or near drop offs, always have ROPS (roll over protection) installed.
- When operating a machine with ROPS (roll over protection) always use seat belt.
- Be certain that the seat belt can be released quickly if the machine is driven or rolls into ponds or water.
- Check carefully for overhead clearances (i.e. branches, doorways, electrical wires) before driving under any objects and do not contact them.

#### DO NOT

- Do not mow slopes exceeding 15 degrees.
- Avoid turning on slopes. If you must turn, turn slowly and gradually downhill, if possible.
- Do not mow near drop-offs, ditches, or embankments. The machine could suddenly turn over if a wheel goes over the edge of a cliff or ditch, or if an edge caves in.

- Do not mow on wet grass. Reduced traction could cause sliding.
- Do not use a grass catcher on steep slopes. Heavy grass bags could cause loss of control or overturn the machine.

## **Service**

- Never store the machine or fuel container inside where there is an open flame, such as near a water heater or furnace.
- Keep nuts and bolts tight, especially the blade attachment bolts. Keep equipment in good condition.
- Never tamper with safety devices. Check safety systems for proper operation before each use.
- Use only genuine replacement parts to ensure that original standards are maintained.
- Check brake operation frequently. Adjust and service as required.
- Battery acid is poisonous and can cause burns. Avoid contact with skin, eyes and clothing. Protect your face, eyes and clothing when working with a battery.
- Battery gases can explode. Keep cigarettes, sparks and flames away from battery.
- Hydraulic fluid escaping under pressure can penetrate the skin and cause injury. Use cardboard or paper to find hydraulic leaks. Never use your hands.

# Slope Chart

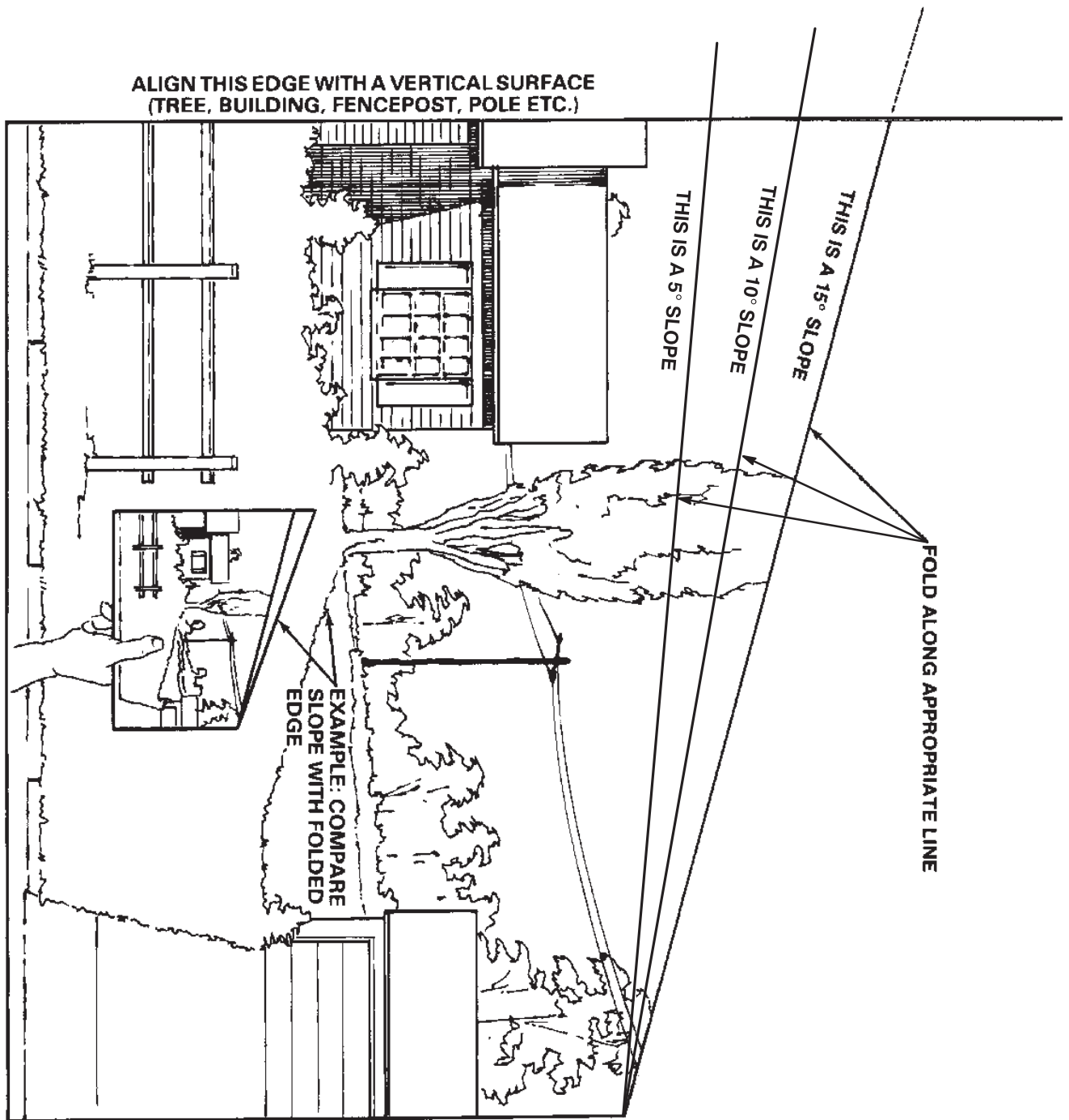





# Safety and Instruction Decals



Safety decals and instructions are easily visible to the operator and are located near any area of potential danger. Replace any decal that is damaged or lost.



98-4387

1. Warning—wear hearing protection.



98-5954



104-8569



66-1340

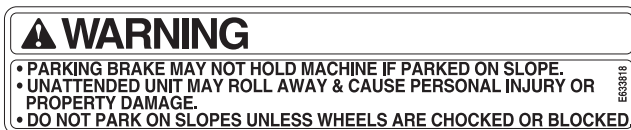

1-633818



43-8480



54-9220



1-643401



67-5360

**TORO** LANDSCAPE CONTRACTOR EQUIPMENT

• 15 W 50 SYNTHETIC OIL  
• LONGER HYDRAULIC LIFE  
• LESS MAINTENANCE  
• INCREASED PRODUCTIVITY

**1**<sup>®</sup>

104-8172

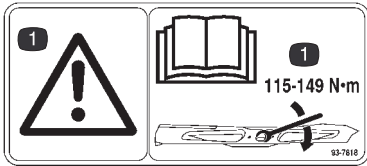

93-7818

- Warning—torque the blade bolt to 115–149 N·m (85–110 ft.-lb.). Read the operator's manual for further instructions.

**ANTI-SCALP ROLLER ADJUSTMENT**

FOR MAXIMUM DECK FLOTATION, PLACE ROLLERS IN POSITIONS SHOWN.

TURN ENGINE OFF BEFORE MAKING ROLLER ADJUSTMENTS.

- 1.5" / 38mm
- 2.0" / 51mm
- 2.5" / 63mm
- 3.0" / 76mm

98-3798

98-3798

**See important warning information on side label!**

**Voir information d'avertissement importante sur l'étiquette de côté!**

**¡Aviso importante favor de observar las instrucciones en la etiqueta lateral!**

104-4163

- Explosion hazard
- No sparks, flame, or smoking
- Caustic liquid hazard—burns to hand and damage to items.
- Wear eye protection.
- Read the operator's manual.
- Keep bystanders away.

MAINTENANCE FREE • SANS ENTRETIEN • LIBRE DE MANTENIMIENTO

NIVEAU MAXIMUM / NIVEAU MINIMUM, MAXIMUM FILL / MINIMUM FILL, CAPACIDAD MAXIMA / CAPACIDAD MINIMA

**⚠ DANGER/POISON ¡PELIGRO/VENENO!**

<p><b>SHIELD EYES.</b> EXPLOSIVE GASES CAN CAUSE BLINDNESS OR INJURY.</p> <p><b>PROTÉGER LES YEUX. GAZ EXPLOSIFS</b> PEUVENT RENDRE AVEUGLE OU PROVOQUER DES LÉSIONS.</p> <p><b>PROTEJA LOS OJOS. GASES EXPLOSIVOS</b> PUEDEN CAUSAR CEGUERA O DAÑO.</p>	<p><b>NO SPARKS • FLAMES • SMOKING</b></p> <p><b>ÉLOIGNER</b> • ÉTINCELLES • FLAMMES • CIGARETTES</p> <p><b>NO CHISPAS • FLAMAS • FUMAR</b></p>	<p><b>SULFURIC ACID CAN CAUSE BLINDNESS OR SEVERE BURNS.</b></p> <p><b>ACIDE SULFURIQUE</b> PEUT RENDRE AVEUGLE OU PROVOQUER DES BRÛLURES GRAVES.</p> <p><b>ACIDO SULFURICO</b> PUEDA CAUSAR CEGUERA O QUEMADURAS SEVERAS.</p>	<p><b>FLUSH EYES IMMEDIATELY WITH WATER. GET MEDICAL HELP FAST.</b></p> <p><b>RINCER IMMEDIATEMENT LES YEUX A GRANDE EAU. CONTACTER RAPIDEMENT UN MEMBRE DE LA PROFESSION MEDICALE.</b></p> <p><b>LAVE LOS OJOS DE INMEDIATO. CONSIGA AYUDA MEDICA RAPIDO.</b></p>
--	---	--	--

**HOW TO ACTIVATE DRY CHARGED BATTERIES**

- Use only battery electrolyte (1.265 Sp.Gr.) to fill battery initially.
- Do not overfill. Let stand for 15 minutes.
- Charge battery at 4-5 amps until specific gravity is 1.250 or higher and temperature is at least 60°F. — all cells gassing freely.
- After battery has been activated, add only water to replace normal loss.

**KEEP OUT OF THE REACH OF CHILDREN. DO NOT TIP. DO NOT OPEN BATTERY!**  
**MAINTENIR HORS DE LA PORTÉE DES ENFANTS. NE RENVERSEZ PAS. N'OUVREZ PAS LA BATTERIE!**  
**MANTENGASE FUERA DEL ALCANCE DE LOS NIÑOS. NO INCLINE. NO ABRA LA BATERIA!**

3-4808 Dist. by: /por:/par: The Toro Company, Bloomington, MN 55420 MADE IN U.S.A. • FABRIQUE AUX É.U.A. • HECHO EN E.U.A.

104-4164

- Contains lead—do not throw the battery in the garbage.



1-403005



65-2690



1-653140

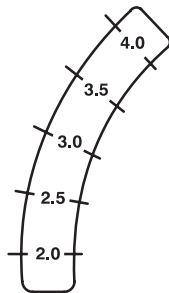

1-653147

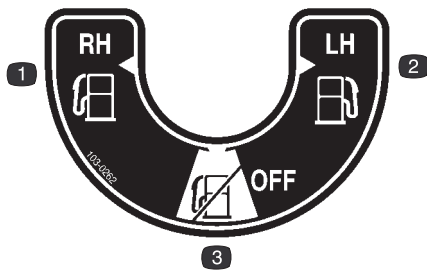

103-0262

- 1. Right-hand fuel tank on
- 2. Left-hand fuel tank on
- 3. Fuel shut-off

**CHECK SERVICE REFERENCE AID**

- GREASE LUBE POINTS AT INTERVALS SHOWN.
- ▲ CHECK HYDRAULIC FLUID AT INTERVAL SHOWN. (USE ONLY MOBIL 1 15W-50 SYNTHETIC MOTOR OIL.)
- ② SEE ENGINE OPERATOR'S MANUAL FOR SERVICING ENGINE.
- ③ CHECK TIRE PRESSURE - 13 PSI AT INTERVAL SHOWN. SEE OPERATOR'S MANUAL FOR ADDITIONAL DETAILS.

99-3924

99-3924

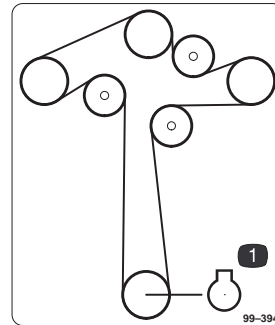

99-3943

- 1. Engine pulley

**DISENGAGE**

↑

↓

**ENGAGE**

**(P)**

**BRAKE**

**⚠ DANGER** TO AVOID SERIOUS INJURY OR DEATH:

- READ AND UNDERSTAND OPERATOR'S MANUAL.
- USE SAFELY; MACHINE IS NOT A TOY.
- NEVER USE WHEN UNDER THE INFLUENCE OF ALCOHOL OR DRUGS.
- KNOW LOCATION AND FUNCTION OF CONTROLS.
- KEEP SAFETY SHIELDS IN PLACE AND WORKING.
- CHECK PERFORMANCE OF ALL INTERLOCK SWITCHES DAILY. DO NOT DEFEAT INTERLOCK SYSTEM. IT IS FOR YOUR PROTECTION.
- STOP ENGINE, SET PARKING BRAKE & REMOVE KEY BEFORE LEAVING MACHINE.
- DO NOT ALLOW OPERATION OF MACHINE BY UNTRAINED PERSONNEL.

OFF RUN

START

**IGNITION**

ON

OFF

**PTO**

IMPORTANT: BEFORE STARTING ENGINE CLEAN GRASS FROM PUMP COMPARTMENT. CHECK MORE OFTEN IN DRY CONDITIONS.

**CHOKE**

**THROTTLE**

FOR REPLACEMENT MANUAL, SEND MODEL & SERIAL NUMBER TO: THE TORO COMPANY, 5111 LYNDALE AVE. S., BLOOMING TON, MN 55425.

**⚠ DANGER**

- NEVER CARRY CHILDREN OR OTHER PASSENGERS.
- LOOK DOWN AND BEHIND BEFORE & WHILE BACKING UP.
- NEVER MOW WHEN CHILDREN, PEOPLE OR PETS ARE IN MOWING AREA.
- GO UP AND DOWN SLOPES, NOT ACROSS.
- IF MACHINE STOPS GOING UP HILL, STOP BLADE AND BACK SLOWLY DOWN.
- AVOID SHARP OR SUDDEN TURNS & SLIPPERY OR STEEP AREAS.
- AVOID BLADE UNLESS BLADE AND ENGINE ARE STOPPED.
- REMOVE OBJECTS THAT COULD BE THROWN BY THE BLADE.
- THROWN OBJECTS OR BLADE CONTACT CAN CAUSE SERIOUS INJURY OR DEATH.

NEVER MOW HILLSIDES

99-3942

**MOTION CONTROL**

↑

↓

**N**

**R**

**⚠ CAUTION**

Battery is 600 watts & extremely hot and can cause severe burns. Never attempt to repair or repair switch. Always disconnect battery. See operator's manual for disposal guide.

**⚠ WARNING**

Battery contains sulfuric acid. Avoid contact and always shield eyes, face, skin and clothing from battery. Engulfed, inhaled or sparks could cause battery to explode. Do not charge or use booster cables or adjust post connections without proper training. In event of an accident flush with water and call a physician immediately. Keep out of reach of children.

**DRIVE ENG. RELEASE**

See the operator's manual for instructions. Do not use if not installed.

**MOTION CONTROL**

↑

↓

**N**

**R**



103-1997

# Gasoline and Oil

## Recommended Gasoline



Use UNLEADED Regular Gasoline suitable for automotive use (85 pump octane minimum). Leaded regular gasoline may be used if unleaded regular is not available.

**Important** Never use methanol, gasoline containing methanol, or gasohol containing more than 10% ethanol because the fuel system could be damaged. Do not mix oil with gasoline.

 **Danger** 

In certain conditions, gasoline is extremely flammable and highly explosive. A fire or explosion from gasoline can burn you and others and can damage property.

- Fill the fuel tank outdoors, in an open area, when the engine is cold. Wipe up any gasoline that spills.
- Never fill the fuel tank inside an enclosed trailer.
- Do not fill the fuel tank completely full. Add gasoline to the fuel tank until the level is 1/4 to 1/2 in. (6 to 13 mm) below the bottom of the filler neck. This empty space in the tank allows gasoline to expand.
- Never smoke when handling gasoline, and stay away from an open flame or where gasoline fumes may be ignited by a spark.
- Store gasoline in an approved container and keep it out of the reach of children. Never buy more than a 30-day supply of gasoline.
- Always place gasoline containers on the ground away from your vehicle before filling.
- Do not fill gasoline containers inside a vehicle or on a truck or trailer bed because interior carpets or plastic truck bed liners may insulate the container and slow the loss of any static charge.
- When practical, remove gas-powered equipment from the truck or trailer and refuel the equipment with its wheels on the ground.
- If this is not possible, then refuel such equipment on a truck or trailer from a portable container, rather than from a gasoline dispenser nozzle.
- If a gasoline dispenser nozzle must be used, keep the nozzle in contact with the rim of the fuel tank or container opening at all times until fueling is complete.

 **Warning** 

**Gasoline is harmful or fatal if swallowed. Long-term exposure to vapors can cause serious injury and illness.**

- Avoid prolonged breathing of vapors.
- Keep face away from nozzle and gas tank or conditioner opening.
- Keep gas away from eyes and skin.

## Using Stabilizer/Conditioner

Use a fuel stabilizer/conditioner in the machine to provide the following benefits:

- Keeps gasoline fresh during storage of 90 days or less. For longer storage it is recommended that the fuel tank be drained.
- Cleans the engine while it runs
- Eliminates gum-like varnish buildup in the fuel system, which causes hard starting

**Important** Do not use fuel additives containing methanol or ethanol.

Add the correct amount of gas stabilizer/conditioner to the gas.

**Note:** A fuel stabilizer/conditioner is most effective when mixed with fresh gasoline. To minimize the chance of varnish deposits in the fuel system, use fuel stabilizer at all times.

## Filling the Fuel Tank

1. Shut the engine off and set the parking brake.
2. Clean around each fuel tank cap and remove the cap. Add unleaded regular gasoline to both fuel tanks, until the level is 1/4 to 1/2 inch (6 to 13 mm) below the bottom of the filler neck. This space in the tank allows gasoline to expand. Do not fill the fuel tanks completely full.
3. Install fuel tank caps securely. Wipe up any gasoline that may have spilled.

## Checking the Engine Oil Level

Before you start the engine and use the machine, check the oil level in the engine crankcase; refer to Checking the Engine Oil Level, page 30.

# Setup

**Note:** Determine the left and right sides of the machine from the normal operating position.

## Loose Parts

**Note:** Use the chart below to verify that all parts have been shipped.

Description	Qty.	Use
Rear wheels	2	Installing the wheels to the traction unit
Retaining rod	1	Installing the seat rod
Bolt, 5/16 x 1 in.	1	
Locknut, 5/16 in.	1	
Control lever—right	1	Installing the motion control levers
Control lever—left	1	
Bolt, 3/8 x 1 in.	4	
Spring washer, 3/8 in.	4	
Key	2	Read before operating the machine.
Operator's Manual	1	
Engine Operator's Manual	1	
Parts Catalog	1	
Registration card	1	Fill out and return to Toro.

## Installing the Drive Wheels

1. Uncrate the mower.
2. Remove the wheel bolts or nuts from the rear wheel hubs.
3. Align the holes. Mount the drive wheels with the valve stem to the outside of the traction unit.
4. Secure the wheels using the wheel bolts or nuts provided. Torque to 95 ft.-lb. (128 N-m).

## Checking the Tire Pressure

Check the air pressure in the front and rear tires (Fig. 2).

Pressure: 13 psi (90 kPa)

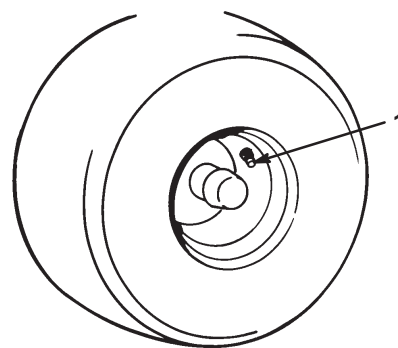

**Figure 2**

1. Valve stem

m-1872

## Installing the Seat Retaining Rod

1. Tilt the seat up. Remove the locknut (5/16 in.) from the bolt attaching the seat retaining rod to the seat frame (Fig. 3).
2. Remove the retaining rod from the seat and insert the "L" shaped end of the rod into the hole directly above the left-side hydraulic pump (Fig. 3).
3. Place the seat retaining rod to the outside of the mounting tab of the seat frame and secure it with the bolt (5/16 x 1 in.) and locknut (5/16 in.) (Fig. 3).
4. Tighten until snug, then loosen them so that the rod pivots freely.

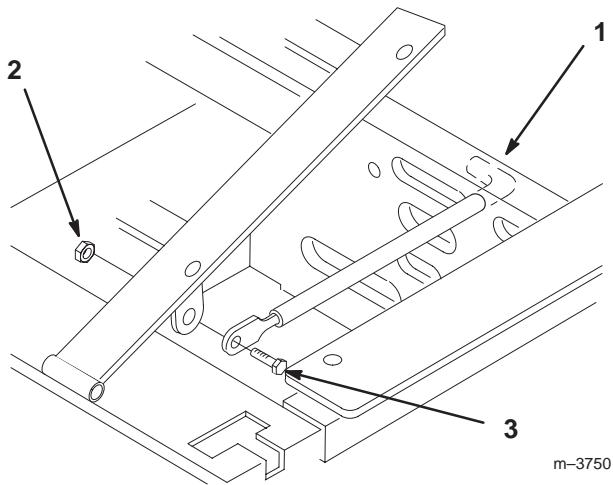

Figure 3

1. L end of retaining rod
2. Locknut, 5/16 in.
3. Bolt, 5/16 x 1 in.

## Installing the Motion Control Levers

There are two positions to install the control levers: high and low. Install the levers in the top and middle holes for the high position. Install the levers in the middle and bottom holes for the low position.

1. Remove the 4 bolts (3/8 x 1 in.) and 4 spring washers (3/8 in.) which attach the motion control levers to the control arm shafts for shipping (Fig. 4).
2. Place the levers (with the mounting plate toward the rear) on the outside of the control arm shaft and secure them with 4 bolts (3/8 x 1 in.) and 4 spring washers (3/8 in.) (Fig. 4).
3. Position the lever so that the bolts are in the center of the slots on the lever mounting plate and tighten until snug.

4. Align the front/rear position of the levers, with each other, in the neutral position. Loosen the hardware and adjust by sliding/tilting the lever(s) forward or backward until they are properly aligned (Fig. 4).

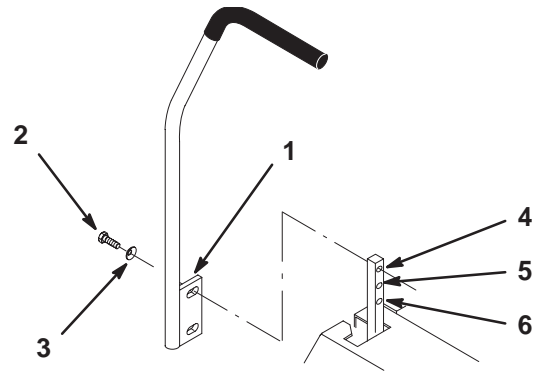

m-5596

Figure 4

1. Mounting plate
2. Bolt, 3/8 x 1 in.
3. Spring washer, 3/8 in.
4. Top hole
5. Middle hole
6. Bottom hole

5. If the ends of the levers hit against each other while in the drive position (Fig. 5) (levers rotated in as far as possible), make adjustments by moving the levers outward to the neutral lock position and carefully bend them outward. Move them back to the drive position and check for clearance. Repeat if necessary.

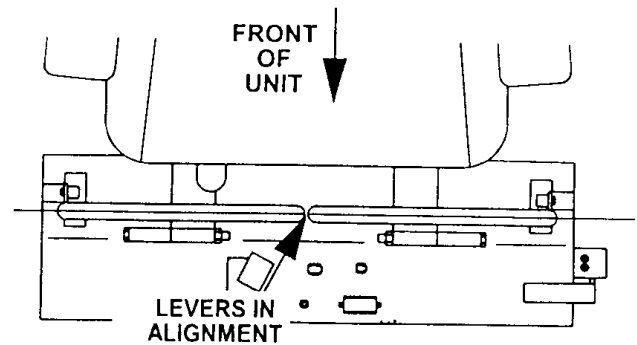

Figure 5

## Activating the Battery

Bulk electrolyte with 1.265 specific gravity must be purchased from a local battery supply outlet.

**Danger**

Battery electrolyte contains sulfuric acid which is a deadly poison and causes severe burns.

- Do not drink electrolyte and avoid contact with skin, eyes or clothing. Wear safety glasses to shield your eyes and rubber gloves to protect your hands.
- Fill the battery where clean water is always available for flushing the skin.
- Follow all instructions and comply with all safety messages on the electrolyte container.

1. Remove the battery from the machine; refer to Removing the Battery, page 44.
  2. Clean the top of the battery with a paper towel.
- Note:** Never fill the battery with electrolyte while the battery is installed in the machine. Electrolyte could be spilled on other parts and cause corrosion.
3. Remove the vent caps from the battery (Fig. 6).
  4. Slowly pour electrolyte into each battery cell until the level is up to the **upper** line (Fig. 6) on the battery case.

**Important** Do not overfill the battery because electrolyte (sulfuric acid) can cause severe corrosion and damage to the chassis.

5. Wait five to ten minutes after filling the battery cells. Add electrolyte, if necessary, until the electrolyte level is up to the **upper** line (Fig. 6) on the battery case.
6. Reinstall battery filler caps.

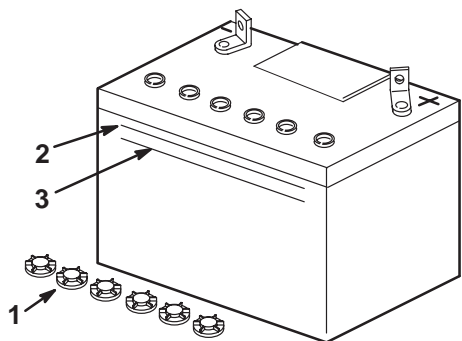

Figure 6

m-5004

1. Filler caps
2. **Upper** line
3. **Lower** line

**Warning**

Charging battery produces gasses that can explode and cause serious injury.

- Keep cigarettes, sparks and flames away from battery.
- Make sure the ignition switch is off.
- Ventilate when charging or using battery in an enclosed space.

7. Charge the battery; refer to Charging the Battery, page 45.
8. Install the battery into the machine; refer to Installing the Battery, page 43.

**Note:** Do not run the machine with the battery disconnected, electrical damage may occur.

## Checking the Hydraulic Fluid

Check the hydraulic fluid level before the engine is first started; refer to Checking the Hydraulic Fluid, page 35.

## Greasing the Bearings

**Important** Make sure that the cutting unit spindles are full of grease before the engine is first started.

Grease with No. 2 general purpose lithium base or molybdenum base grease.

Grease the fittings on the three spindle bearings. Grease until it comes out of the lower seals (Fig. 7).

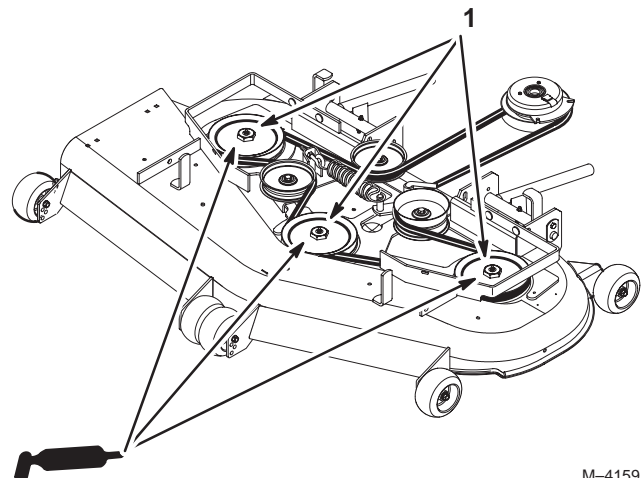

Figure 7

M-4159

1. Spindles



## Checking the Leveling of the Mower Deck

Check the level of the deck before the machine is first put into use.

Refer to Adjusting the Mower Level, page 39, in the Maintenance section.

## Checking the Side Discharge Chute

Remove the plastic tie holding the side discharge chute up and lower it into place.

## Checking the Engine Oil Level

Before you start the engine and use the machine, check the oil level in the engine crankcase; refer to Checking the Oil Level, page 30.

# Operation

**Note:** Determine the left and right sides of the machine from the normal operating position.

## Think Safety First

Please read all of the safety instructions and symbols in the safety section. Knowing this information could help you, your family, pets, or bystanders avoid injury.

The use of protective equipment for eyes, ears, feet, and head is recommended.

⚠
Caution
⚠

**This machine produces sound levels in excess of 85 dBA at the operators ear and can cause hearing loss through extended periods of exposure.**

**Wear hearing protection when operating this machine.**

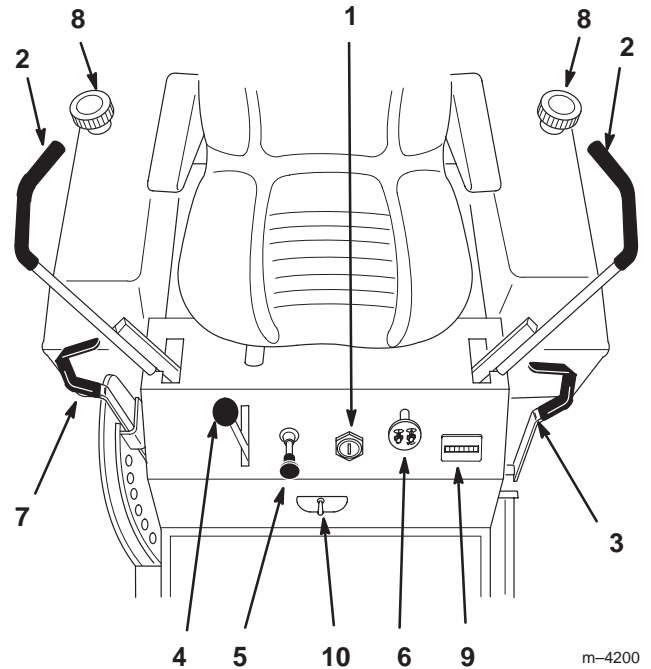

**Figure 8**

1. Caution                      2. Wear hearing protection

## Controls

Become familiar with all the controls (Fig. 9) before you start the engine and operate the machine.

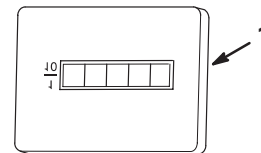

**Figure 9**

- |                         |                         |
|-------------------------|-------------------------|
| 1. Ignition switch      | 6. Power take off (PTO) |
| 2. Motion control lever | 7. Height-of-cut lever  |
| 3. Parking brake lever  | 8. Fuel cap             |
| 4. Throttle             | 9. Hourmeter            |
| 5. Choke                | 10. Fuel shut-off valve |

## Using the Hour Meter

The hour meter records the number of hours the engine has operated. It operates when the engine is running. Use these times for scheduling regular maintenance.



**Figure 10**

1. Hour meter

## Switching the Fuel Tanks

The unit has two fuel tanks, one located on the left side and one on the right side. Each tank connects to the fuel shut-off valve in the control panel. From there a common fuel line leads to the engine (Fig. 11).

To use the right side fuel tank, rotate the fuel shut-off valve 1/4 turn to the right from the off location. This uses fuel from the right side tank only. When the right fuel tank is empty, move the fuel shut off valve 1/4 turn to the left from the off position.

Close the fuel shut-off valve, on the front panel, before transporting or storing the machine.

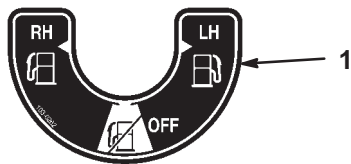

Figure 11

1. Shut-off valve

## Operating the Parking Brake

Always set the parking brake when you stop the machine or leave it unattended.

**Important** Do not park on slopes unless the wheels are chocked or blocked.

### Setting the Parking Brake

1. Move the motion control levers (Fig. 12) out to the neutral lock position.
2. Pull back and up on the parking brake lever to set the parking brake (Fig. 12). The parking brake lever should stay firmly in the Engaged position.

### Releasing the Parking Brake

Push forward and down on the parking brake lever to release the parking brake (Fig. 12). The parking brake is disengaged.

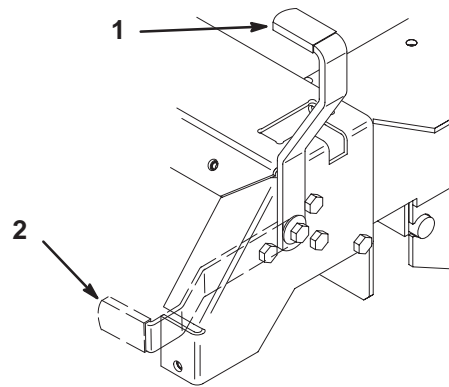

Figure 12

1. Parking brake—On
2. Parking brake—Off

m-4121

## Starting and Stopping the Engine

### Starting the Engine

1. Sit down on the seat and move the motion controls to the neutral locked position.
2. Set the parking brake; refer to Setting the Parking Brake, page 18.
3. Move the PTO (power take off) to Off (Fig. 13).
4. Move the choke control to the On position before starting a cold engine (Fig. 14).

**Note:** A warm or hot engine may require choking. After the engine starts, move the choke control to the Off position.

5. Move the throttle control to the Fast position before starting a cold engine (Fig. 15).
6. Turn the ignition key to Start to energize the starter. When the engine starts, release the key (Fig. 16).

**Important** Do not engage the starter for more than 10 seconds at a time. If the engine fails to start, allow a 30 second cool-down period between attempts. Failure to follow these instructions can burn out the starter motor.

7. After the engine starts, move the choke to Off (Fig. 14). If the engine stalls or hesitates, move the choke back to On for a few seconds. Then move the throttle lever to the desired setting. Repeat this as required.

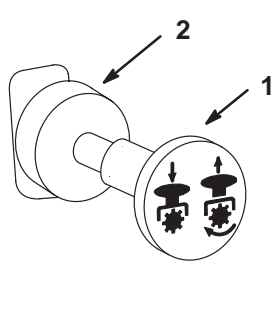

m-4201

**Figure 13**

1. PTO—On
2. PTO—Off

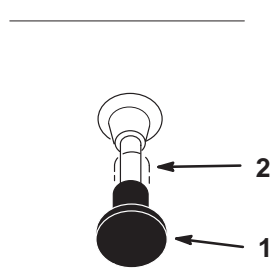

m-2719

**Figure 14**

1. Choke—On
2. Choke—Off

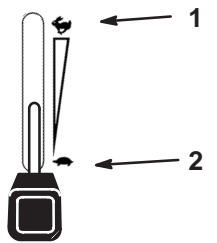

m-2720

**Figure 15**

1. Fast
2. Slow

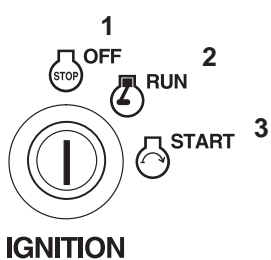

M-4268

**Figure 16**

1. Off
2. Run
3. Start

**Important** Make sure fuel shut off valve is closed before transporting or storing machine, as fuel leakage may occur. Set parking brake before transporting.

## Operating the Power Take Off (PTO)

The power take off (PTO) switch engages and disengages power to the electric clutch.

### Engaging the PTO

1. While seated in the seat, release the pressure on the traction control levers and place in neutral.
2. Place the throttle in the fast position.
3. Pull out on the power take off (PTO) switch to engage (Fig. 17).

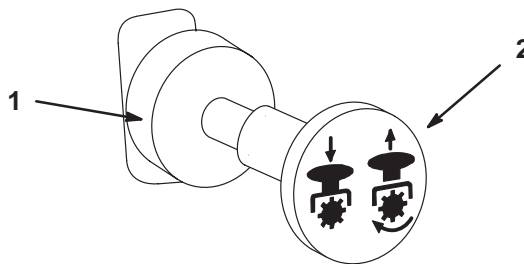

m-4201

**Figure 17**

1. PTO—Off
2. PTO—On



## Stopping the Engine

1. Push the PTO to off (Fig. 15).
2. Move the throttle lever midway between the slow and fast positions (Fig. 15).
3. Let the engine idle for 60 seconds (Fig. 16).
4. Turn the ignition key to off (Fig. 16).
5. Pull wire off spark plug(s) to prevent possibility of someone accidentally starting the machine before transporting or storing machine.
6. Close fuel shut off valve, on front panel before transporting or storing machine.

## Disengaging the PTO

To disengage, push the PTO switch to the Off position (Fig. 17).

# The Safety Interlock System

 **Caution** 

**If safety interlock switches are disconnected or damaged the machine could operate unexpectedly causing personal injury.**

- **Do not tamper with the interlock switches.**
- **Check the operation of the interlock switches daily and replace any damaged switches before operating the machine.**

## Understanding the Safety Interlock System

The safety interlock system is designed to prevent the engine from starting unless:

- You are sitting on the seat.
- The parking brake is engaged.
- The power take off (PTO) is disengaged.
- The motion control levers are in the neutral lock position.

The safety interlock system also is designed to stop the engine when the traction controls are moved with the parking brake on **engaged** or if you rise from the seat when the PTO is **on** or engaged.

## Testing the Safety Interlock System



Test the safety interlock system before you use the machine each time. If the safety system does not operate as described below, have an Authorized Service Dealer repair the safety system immediately.

1. Sitting on the seat, engage the parking brake, and move the PTO On. Try starting the engine; the engine should not crank.
2. Sitting on the seat, engage the parking brake, and move the PTO to Off. Move either motion control lever (forward or reverse). Try starting the engine; the engine should not crank. Repeat for the other motion control lever.

3. Sitting on the seat, engage the parking brake, move the PTO to Off, and lock the motion control levers in neutral. Now start the engine. While the engine is running, release the parking brake, engage the PTO and rise slightly from the seat; the engine should stop.
4. Sitting on the seat, engage the parking brake, move the PTO to Off, and lock the motion control levers in neutral. Now start the engine. While the engine is running, center the motion controls and move (forward or reverse); the engine should stop.
5. Sitting on the seat, disengage the parking brake, move the PTO switch to Off, and move the motion control levers to the neutral lock position. Try starting the engine; the engine should not crank.

## Driving Forward or Backward

The throttle control regulates the engine speed as measured in RPM (revolutions per minute). Place the throttle control in the Fast position for best performance. Always operate in the full throttle position.

 **Caution** 

**Machine can spin very rapidly. Operator may lose control of machine and cause personal injury or damage to machine.**

- **Use caution when making turns.**
- **Slow the machine down before making sharp turns.**

## Driving Forward

1. Release the parking brake; refer to Releasing the Parking Brake, page 18.
2. Move the levers to the center, unlocked position.
3. To go forward, slowly push the motion control levers forward (Fig. 18).

**Note:** The engine will kill if the traction control levers are moved with the parking brake engaged.

To go straight, apply equal pressure to both motion control levers (Fig. 18).

To turn, release pressure on the motion control lever toward the direction you want to turn (Fig. 18).

The farther you move the traction control levers in either direction, the faster the machine will move in that direction.

To stop, pull the motion control levers to neutral.

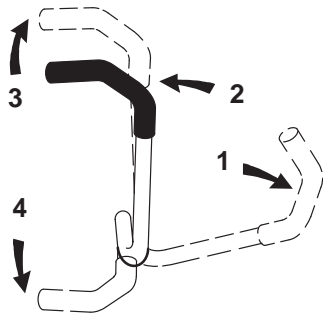

m-2715

**Figure 18**

- |   |                           |
|---|---------------------------|
| 1. Motion control lever—neutral lock position | 2. Center unlock position |
|   | 3. Forward                |
|   | 4. Backward               |

## Driving Backward

1. Move the levers to the center, unlocked position.
2. To go backward, slowly pull the motion control levers rearward (Fig. 18).

To go straight, apply equal pressure to both motion control levers (Fig. 18).

To turn, release pressure on the motion control lever toward the direction you want to turn (Fig. 18).

To stop, push the motion control levers to neutral.

## Stopping the Machine

To stop the machine, move the traction control levers to neutral and separate to lock, disengage the power take off (PTO), and turn the ignition key to Off to stop the engine. Also set the parking brake when you leave the machine; refer to Setting the Parking Brake, page 18. Remember to remove the key from the ignition switch.

⚠
Caution
⚠

**Children or bystanders may be injured if they move or attempt to operate the tractor while it is unattended.**

**Always remove the ignition and set the parking brake when leaving the machine unattended, even if just for a few minutes.**

## Adjusting the Height-of-Cut

The height-of-cut is adjusted from 1-1/2 to 4-1/2 in. (38 to 114 mm) in 1/4 in. (6 mm) increments by relocating the clevis pin in different hole locations.

1. Raise the height-of-cut lever to the transport position (also the 4-1/2 in. [114 mm] cutting height position) (Fig. 19).
2. To adjust, remove the hairpin cotter and clevis pin from the height-of-cut bracket (Fig. 19).
3. Select the hole in the height-of-cut bracket corresponding to the height-of-cut desired, and insert the clevis pin (Fig. 19).
4. Secure the clevis pin with the hairpin cotter (Fig. 19).

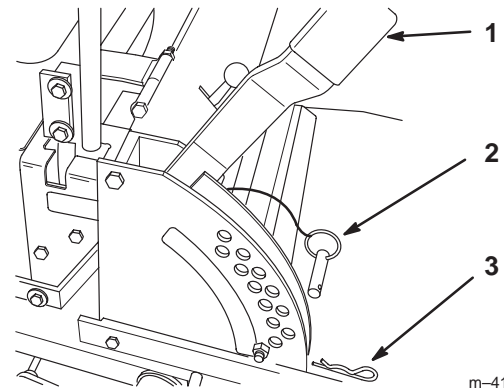

m-4122

**Figure 19**

- |                        |                   |
|------------------------|-------------------|
| 1. Height-of-cut lever | 3. Hairpin cotter |
| 2. Clevis pin          |                   |

5. Lower the height-of-cut lever onto the clevis pin (Fig. 19).

## Adjusting the Anti-Scalp Rollers

Whenever you change the height-of-cut it is recommended to adjust the height of the anti-scalp rollers.

### Adjusting the Outer Rollers

1. Disengage the power take off (PTO) and turn the ignition key to Off. Move the control levers to the neutral locked position and apply the parking brake. Remove the key.
2. After adjusting the height-of-cut, remove the nut and washer while holding the stud with a wrench (Fig. 20).

**Note:** Do not remove the wheel nut and washer (Fig. 20).

3. Select a hole so that the gage wheel is positioned to the nearest corresponding height-of-cut desired (Fig. 20).

4. Reinstall the stud nut and washer (Fig. 20).
5. Repeat the adjustment on the other gage wheels.

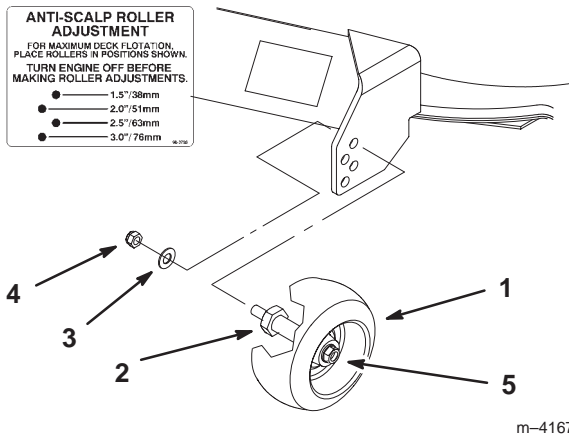

**Figure 20**

- |               |  |
|---------------|--|
| 1. Gage wheel | 4. Nut                                     |
| 2. Stud       | 5. Wheel nut and washer.<br>Do not remove. |
| 3. Washer     |  |

## Positioning the Seat

The seat can move forward and backward. Position the seat where you have the best control of the machine and are most comfortable.

1. To adjust, move the lever sideways to unlock seat (Fig. 22).
2. Slide the seat to the desired position and release the lever to lock the seat in position.

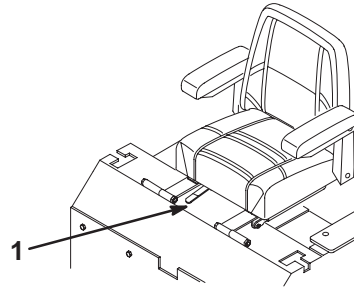

**Figure 22**

1. Adjustment lever

## Adjusting the Center Rollers

1. Disengage the power take off (PTO) and turn the ignition key to Off. Move the control levers to the neutral locked position and apply the parking brake.
1. After adjusting the height-of-cut, remove the bolt and nut (Fig. 21).
2. Select a hole so that the gage wheel is positioned to the nearest corresponding height-of-cut desired (Fig. 21).

**Note:** Do not adjust the rollers to support the deck.

3. Reinstall the bolt, center rollers, and nut (Fig. 21).

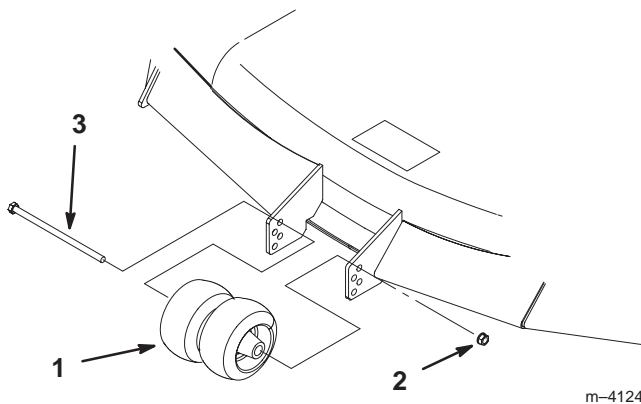

**Figure 21**

- |                              |         |
|------------------------------|---------|
| 1. Center rollers and spacer | 3. Bolt |
| 2. Nut                       |         |

## Pushing the Machine by Hand

**Important** Always push the machine by hand. Never tow the machine because hydraulic damage may occur.

### To Push the Machine

1. Disengage the power take off (PTO) and turn the ignition key to Off.
2. Rotate the by-pass valves counterclockwise 1 turn to push. This allows hydraulic fluid to by-pass the pump enabling the wheels to turn (Fig. 23).

**Important** Do not rotate the by-pass valves more than 1 turn. This prevents the valves from coming out of the body and causing fluid to run out.

### Changing to Machine Operation

Turn the by-pass valves in to operate (Fig. 23).

**Note:** The machine will not drive unless the by-pass valves are turned in.

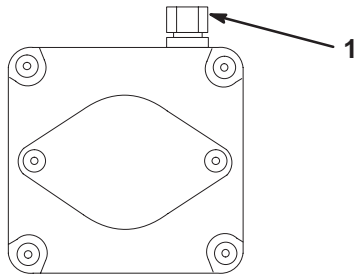

Figure 23

m-5642

1. By-pass valve

## Operating with Side Discharge

The mower has a hinged grass deflector that disperses clippings to the side and down toward the turf.



### Danger



**Without the grass deflector, discharge cover, or complete grass catcher assembly mounted in place, you and others are exposed to blade contact and thrown debris. Contact with rotating mower blade(s) and thrown debris will cause injury or death.**

- Never remove the grass deflector from the mower because the grass deflector routes material down toward the turf. If the grass deflector is ever damaged, replace it immediately.
- Never put your hands or feet under the mower.
- Never try to clear discharge area or mower blades unless you move the power take off (PTO) to *Off* and rotate the ignition key to *Off*. Also remove the key and pull the wire off the spark plug(s).

## Using a Rollover Protection System

Rollover protection systems (ROPS) are available for many riding machines. Contact an Authorized Service Dealer for information on obtaining ROPS for your machine.





## Transporting the Machine

Use a heavy-duty trailer or truck to transport the machine. Ensure that the trailer or truck has all necessary lighting and marking as required by law. Please carefully read all the safety instructions. Knowing this information could help you, your family, pets, or bystanders avoid injury.

To transport the machine:

- Lock the brake and block the wheels.
- Securely fasten the machine to the trailer or truck with straps, chains, cable, or ropes.
- Secure a trailer to the towing vehicle with safety chains.

 **Warning** 

**Driving on street or roadway without turn signals, lights, reflective markings, or a slow moving vehicle emblem is dangerous and can lead to accidents causing personal injury.**

**Do not drive machine on a public street or roadway.**

## Loading the Machine

Use extreme caution when loading units on trailers or trucks. One full width ramp that is wide enough to extend beyond the rear tires is recommended instead of individual ramps for each side of the unit. The lower rear section of the tractor frame extends back between the rear wheels and serves as a stop for tipping backward. Having a full width ramp provides a surface for the frame members to contact if the unit starts to tip backward. If it is not possible to use one full width ramp, use enough individual ramps to simulate a full width continuous ramp.

The ramp should be long enough so that the angles between the ramp and the ground and the ramp and the trailer or truck do not exceed 15 degrees. A steeper angle may cause mower deck components to get caught as the unit moves from ramp to trailer or truck. Steeper angles may also cause the unit to tip backward. If loading on or near a slope, position the trailer or truck so that it is on the down side of the slope and the ramp extends up the slope. This will minimize the ramp angle. The trailer or truck should be as level as possible.

**Important** Do not attempt to turn the unit while on the ramp; you may lose control and drive off of the side.

Avoid sudden acceleration when driving up a ramp and sudden deceleration when backing down a ramp. Both maneuvers can cause the unit to tip backward.



### Warning



**Loading a unit onto a trailer or truck increases the possibility of backward tip-over and could cause serious injury or death.**

- Use extreme caution when operating a unit on a ramp.
- Use only a single, full width ramp; *Do Not* use individual ramps for each side of the unit.
- If individual ramps must be used, use enough ramps to create an unbroken ramp surface wider than the unit.
- *Do not* exceed a 15 degree angle between ramp and ground or between ramp and trailer or truck.
- Avoid sudden acceleration while driving unit up a ramp to avoid tipping backward.
- Avoid sudden deceleration while backing unit down a ramp to avoid tipping backward.

## Tips for Mowing Grass

### Fast Throttle Setting

For best mowing and maximum air circulation, operate the engine at **fast**. Air is required to thoroughly cut grass clippings, so do not set the height-of-cut so low as to totally surround the mower by uncut grass. Always try to have one side of the mower free from uncut grass, which allows air to be drawn into the mower.

### Cutting a Lawn for the First Time

Cut grass slightly longer than normal to ensure that the cutting height of the mower does not scalp any uneven ground. However, the cutting height used in the past is generally the best one to use. When cutting grass longer than 6 inches (15 cm) tall, you may want to cut the lawn twice to ensure an acceptable quality of cut.

### Cut 1/3 of the Grass Blade

It is best to cut only about 1/3 of the grass blade. Cutting more than that is not recommended unless grass is sparse, or it is late fall when grass grows more slowly.

### Mowing Direction

Alternate mowing direction to keep the grass standing straight. This also helps disperse clippings which enhances decomposition and fertilization.



## **Mow at Correct Intervals**

Normally, mow every four days. But remember, grass grows at different rates at different times. So to maintain the same cutting height, which is a good practice, mow more often in early spring. As the grass growth rate slows in mid summer, mow less frequently. If you cannot mow for an extended period, first mow at a high cutting height; then mow again two days later at a lower height setting.

## **Cutting Speed**

To improve cut quality, use a slower ground speed.

## **Avoid Cutting Too Low**

If the cutting width of the mower is wider than the mower you previously used, raise the cutting height to ensure that uneven turf is not cut too short.

## **Long Grass**

If the grass is ever allowed to grow slightly longer than normal, or if it contains a high degree of moisture, raise the cutting height higher than usual and cut the grass at this setting. Then cut the grass again using the lower, normal setting.

## **When Stopping**

If the machine's forward motion must be stopped while mowing, a clump of grass clippings may drop onto your lawn. To avoid this, move onto a previously cut area with the blades engaged.

## **Keep the Underside of the Mower Clean**

Clean clippings and dirt from the underside of the mower after each use. If grass and dirt build up inside the mower, cutting quality will eventually become unsatisfactory.

## **Blade Maintenance**

Maintain a sharp blade throughout the cutting season because a sharp blade cuts cleanly without tearing or shredding the grass blades. Tearing and shredding turns grass brown at the edges, which slows growth and increases the chance of disease. Check the cutter blades daily for sharpness, and for any wear or damage. File down any nicks and sharpen the blades as necessary. If a blade is damaged or worn, replace it immediately with a genuine Toro replacement blade.

# Maintenance

**Note:** Determine the left and right sides of the machine from the normal operating position.

## Recommended Maintenance Schedule

Maintenance Service Interval	Maintenance Procedure
After First Use	<ul style="list-style-type: none"> <li>• Check hydraulic fluid level</li> <li>• Change engine oil</li> <li>• Change hydraulic filter</li> </ul>
Each Use	<ul style="list-style-type: none"> <li>• Check engine oil level</li> <li>• Check safety system</li> <li>• Clean cooling systems<sup>1</sup></li> <li>• Clean mower housing</li> </ul>
Every 5 Hours	<ul style="list-style-type: none"> <li>• Check cutting blades</li> <li>• Grease blade spindle bearings</li> </ul>
Every 25 Hours	<ul style="list-style-type: none"> <li>• Check hydraulic fluid level</li> <li>• Grease chassis<sup>1</sup></li> <li>• Oil linkage bushings<sup>1</sup></li> <li>• Service foam air cleaner<sup>1</sup></li> <li>• Check belts for wear/cracks</li> <li>• Check battery electrolyte</li> <li>• Check tire pressure</li> <li>• Idler pulley pivot</li> </ul>
Every 50 Hours	<ul style="list-style-type: none"> <li>• Service the spark arrester</li> </ul>
Every 100 Hours	<ul style="list-style-type: none"> <li>• Change engine oil<sup>1</sup></li> <li>• Service paper air cleaner<sup>1</sup></li> <li>• Check spark plug(s)</li> <li>• Check hydraulic lines</li> </ul>
Every 200 Hours	<ul style="list-style-type: none"> <li>• Change hydraulic filter</li> <li>• Change oil filter<sup>1</sup></li> <li>• Replace paper air cleaner<sup>1</sup></li> <li>• Replace fuel filter</li> </ul>
Every 300 Hours	<ul style="list-style-type: none"> <li>• Clean cooling system<sup>1</sup></li> </ul>
Every 500 Hours or at Storage	<ul style="list-style-type: none"> <li>• Adjust castor pivot</li> <li>• Adjust wheel hub slotted nut</li> </ul>
Before Storage	<ul style="list-style-type: none"> <li>• Perform all maintenance procedures listed above before storage</li> <li>• Drain gasoline</li> <li>• Charge battery, disconnect cables</li> <li>• Paint chipped surfaces</li> </ul>

<sup>1</sup>More often in dusty, dirty conditions

**Important** Refer to your engine operator's manual for additional maintenance procedures.



## Caution



If you leave the key in the ignition switch, someone could accidentally start the engine and seriously injure you or other bystanders.

Remove the key from the ignition and disconnect the wire from the spark plug(s) before you do any maintenance. Set the wire aside so that it does not accidentally contact the spark plug.

## Servicing the Cutting Blades

Maintain sharp blades throughout the cutting season because sharp blades cut cleanly without tearing or shredding the grass blades. Tearing and shredding turns grass brown at the edges, which slows growth and increases the chance of disease.

Check the cutter blades daily for sharpness, and for any wear or damage. File down any nicks and sharpen the blades as necessary. If a blade is damaged or worn, replace it immediately with a genuine Toro replacement blade. For convenient sharpening and replacement, you may want to keep extra blades on hand.



## Danger



A worn or damaged blade can break, and a piece of the blade could be thrown into the operator's or bystander's area, resulting in serious personal injury or death.

- Inspect the blade periodically for wear or damage.
- Replace a worn or damaged blade.

## Before Inspecting or Servicing the Blades

Park the machine on a level surface, disengage the blade control (PTO) and set the parking brake. Turn the ignition key to Off. Remove the key and disconnect the spark plug wire(s) from the spark plug(s).

## Inspecting the Blades

1. Inspect the cutting edges (Fig. 24). If the edges are not sharp or have nicks, remove and sharpen the blades; refer to Sharpening the Blades, page 28.
2. Inspect the blades, especially the curved area (Fig. 24). If you notice any damage, wear, or a slot forming in this area (item 3 in Fig. 24), immediately install a new blade.

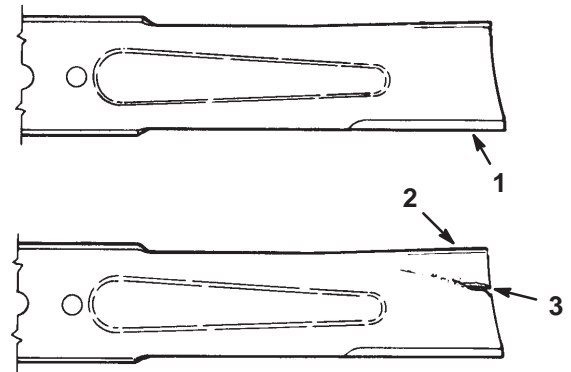

m-151

Figure 24

1. Cutting edge
2. Curved area
3. Wear/slot forming

## Checking for Bent Blades

1. Rotate the blades until the ends face forward and backward (Fig. 25). Measure from a level surface to the cutting edge of the blades (Fig. 26). Note this dimension.

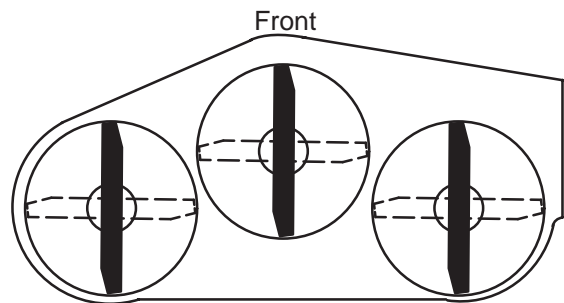

m-1078

Figure 25

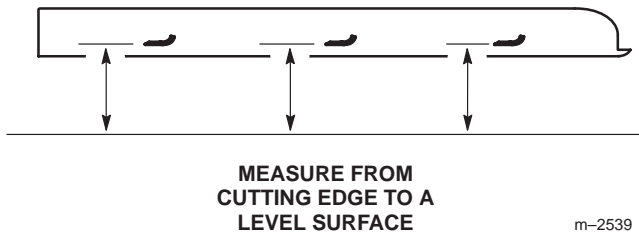

**Figure 26**

m-2539

2. Rotate the opposite ends of the blades forward.
3. Measure from a level surface to the cutting edge of the blades at the same position as in step 1 above. The difference between the dimensions obtained in steps 1 and 3 must not exceed 1/8 in. (3 mm). If this dimension exceeds 1/8 in. (3 mm), the blade is bent and must be replaced; refer to Removing the Blades and Installing the Blades, page 29.

**Warning**

**A blade that is bent or damaged could break apart and could seriously injure or kill you or bystanders.**

- Always replace bent or damaged blade with a new blade.
- Never file or create sharp notches in the edges or surfaces of blade.

## Removing the Blades

The blades must be replaced if a solid object is hit, if the blade is out of balance, or is bent. To ensure optimum performance and continued safety conformance of the machine, use genuine Toro replacement blades. Replacement blades made by other manufacturers may result in non-conformance with safety standards.

Hold the blade end using a rag or thickly-padded glove. Remove the blade bolt, spring disk, and blade from the spindle shaft (Fig. 27).

**Warning**

**Contact with sharp blade can cause serious injury.**

**Wear gloves or wrap sharp edges of the blade with a rag.**

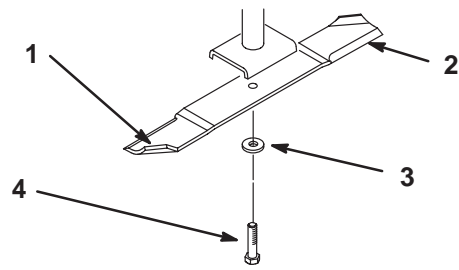

**Figure 27**

m-4318

1. Sail area of blade
2. Blade
3. Spring disk
4. Blade bolt

## Sharpening the Blades

**Warning**

**When sharpening blade, pieces of blade could be thrown and cause serious injury.**

**Wear proper eye protection when sharpening blade.**

1. Use a file to sharpen the cutting edge at both ends of the blade (Fig. 28). Maintain the original angle. The blade retains its balance if the same amount of material is removed from both cutting edges.

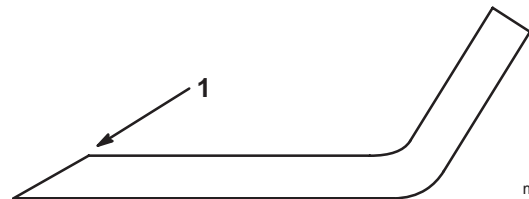

**Figure 28**

m-1854

1. Sharpen at original angle
2. Check the balance of the blade by putting it on a blade balancer (Fig. 29). If the blade stays in a horizontal position, the blade is balanced and can be used. If the blade is not balanced, file some metal off of the end of the sail area only (Fig. 27). Repeat this procedure until the blade is balanced.

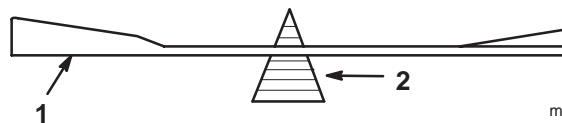

**Figure 29**

m-1855

1. Blade
2. Balancer

## Installing the Blades

1. Install the blade onto the spindle shaft (Fig. 27).

**Important** The curved part of the blade must be pointing upward toward the inside of the mower to ensure proper cutting.

2. Install the flat washer, lock washer, and blade bolt (Fig. 27). Torque the blade bolt to 85–110 ft.-lb. (115–150 N·m).

## Cleaning the Cooling System

Clean the air intake screen from grass and debris before each use.

Clean the cooling fins and engine shrouds every 300 hours or yearly, whichever comes first.

1. Stop the engine, set the parking brake, remove the key, and disconnect the spark plug wire(s) from the spark plug(s).
2. Remove the air intake screen, air cleaner cover, fan housing, and bolts (Fig. 30).
3. Clean debris and grass from the engine shrouds and cooling fins.
4. Reinstall the air intake screen, air cleaner cover, fan housing, and bolts (Fig. 30). Torque the bolts to 4.3 ft.-lb. (5.8 N·m).

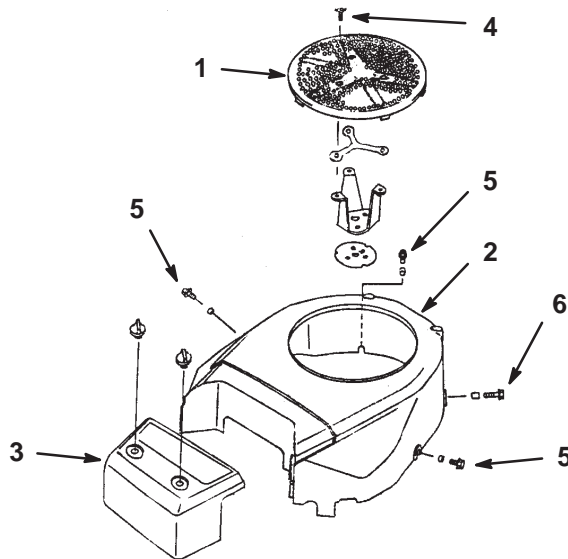

Figure 30

- |                      |                   |
|----------------------|-------------------|
| 1. Air intake screen | 4. M6 x 10mm bolt |
| 2. Fan housing       | 5. M6 x 12mm bolt |
| 3. Air cleaner cover | 6. M6 x 20mm bolt |

## Servicing the Air Cleaner

Foam Element: Clean and oil after every 25 operating hours.

Paper Element: Clean after every 100 operating hours. Replace after every 300 operating hours or yearly, whichever comes first.

**Note:** Service the air cleaner more frequently (every few hours) if operating conditions are extremely dusty or sandy.

## Removing the Foam and Paper Elements

1. Disengage the power take off (PTO), set the parking brake, stop the engine, and remove the key.
2. Clean around the air cleaner to prevent dirt from getting into the engine and causing damage. Remove the cover nuts and cover (Fig. 31).
3. Remove the wing nuts and air cleaner elements (Fig. 31).

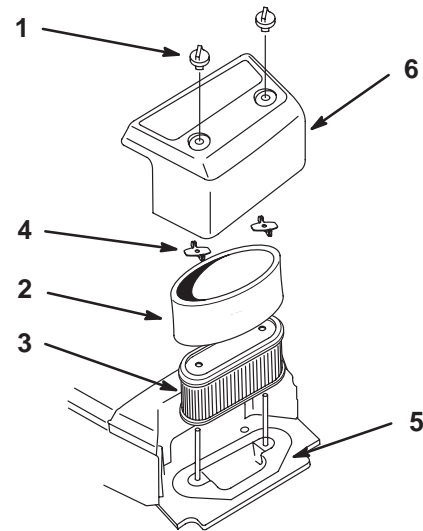

Figure 31

- |                  |                     |
|------------------|---------------------|
| 1. Cover nuts    | 4. Wing nut         |
| 2. Foam element  | 5. Air cleaner base |
| 3. Paper element | 6. Cover            |

4. Carefully remove the foam element from the paper element (Fig. 31).

m-4369

m-4366

## Cleaning the Foam Element

1. Wash the foam element in liquid soap and warm water. When the element is clean, rinse it thoroughly.
2. Dry the element by squeezing it in a clean cloth (do not wring).
3. Soak the element in new engine oil (Fig. 32). Squeeze the element to remove excess oil.

**Important** Replace the foam element if it is torn or worn.

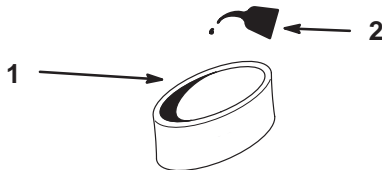

m-4370

**Figure 32**

1. Foam element
2. Oil

## Cleaning the Paper Element

1. Lightly tap the element on a flat surface to remove dust and dirt (Fig. 33).
2. Inspect the element for tears, an oily film, and damage to the rubber seal.

**Important** Never clean the paper element with pressurized air or liquids, such as solvent, gas, or kerosene. Replace the paper element if it is damaged or cannot be cleaned thoroughly.

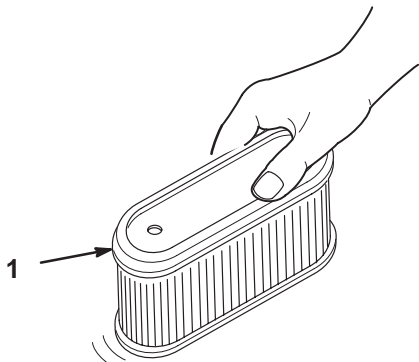

m-4367

**Figure 33**

1. Paper element

## Installing the Foam and Paper Elements

**Important** To prevent engine damage, always operate the engine with the complete foam and paper air cleaner assembly installed.

1. Carefully slide the foam element onto the paper air cleaner element (Fig. 31).
2. Place the air cleaner assembly onto the air cleaner base and install the wing nuts (Fig. 31).
3. Install the air cleaner cover and secure it with the cover nuts (Fig. 31).

## Servicing the Engine Oil

Change the oil:

- After the first 8 operating hours.
- After every 100 operating hours.

**Note:** Change the oil more frequently when operating conditions are extremely dusty or sandy.

Oil Type: Detergent oil (API service SG or SH)

Crankcase Capacity: 51 oz. (1.5 l) (When the oil filter is not removed)

Viscosity: See the table below.

### USE THESE SAE VISCOSITY OILS

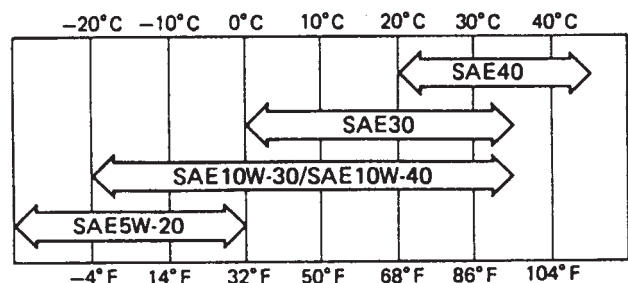

m-4292

## Checking the Oil Level

Check the engine oil level daily.

1. Park the machine on a level surface, disengage the power take off (PTO), stop the engine, and remove the key.
2. Clean around the oil dipstick (Fig. 34) so that dirt cannot fall into the filler hole and damage the engine.
3. Unscrew the oil dipstick and wipe the end clean (Fig. 34).

- Slide the oil dipstick fully into the filler tube. Do not thread it onto the tube (Fig. 34). Pull the dipstick out and look at the end. If the oil level is low, slowly pour only enough oil into the filler tube to raise the level to the full mark.

**Important** Do not overfill the crankcase with oil because the engine may be damaged.

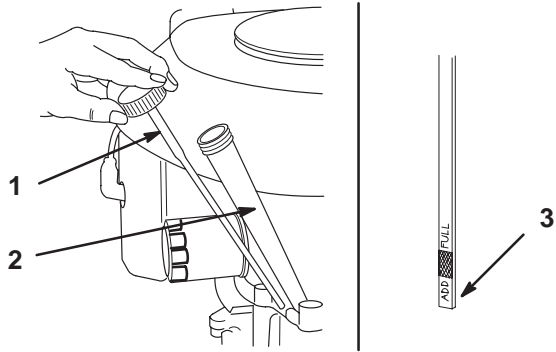

**Figure 34**

- Oil dipstick
- Filler tube
- Dipstick end

## Changing the Oil

- Start the engine and let it run for five minutes. This warms the oil so that it drains better.
- Park the machine so that the drain side is slightly lower than the opposite side to ensure that the oil drains completely. Disengage the power take off (PTO), set the parking brake, stop the engine, and remove the key.
- Place a pan below the oil drain. Use either a flat screw driver, 3/8 in. wrench, or 10 mm wrench to open the valve (Fig. 35).
- Rotate the valve end clockwise to close the valve. Rotate the valve end counterclockwise to open the valve (Fig. 35).
- When the oil has drained completely, close the drain valve (Fig. 35).

**Note:** Dispose of the used oil at a certified recycling center.

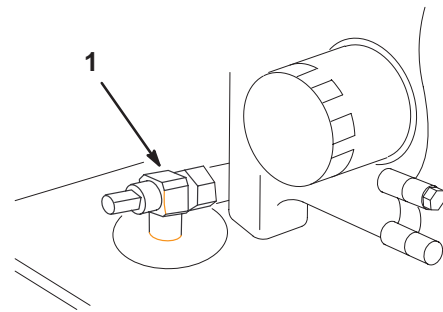

m-5625

**Figure 35**

- Oil drain valve

- Slowly pour approximately 80% of the specified oil, on page 30, into the filler cap (Fig. 34). Now check the oil level; refer to Checking Oil Level, page 30. Slowly add additional oil to bring it to the full mark.

## Changing the Oil Filter

Replace the oil filter every 200 hours or every other oil change.

**Note:** Change the oil filter more frequently when operating conditions are extremely dusty or sandy.

- Drain the oil from the engine; refer to Changing the Oil, page 31.
- Remove the old filter (Fig. 36).
- Apply a thin coat of new oil to the rubber gasket on the replacement filter (Fig. 36).

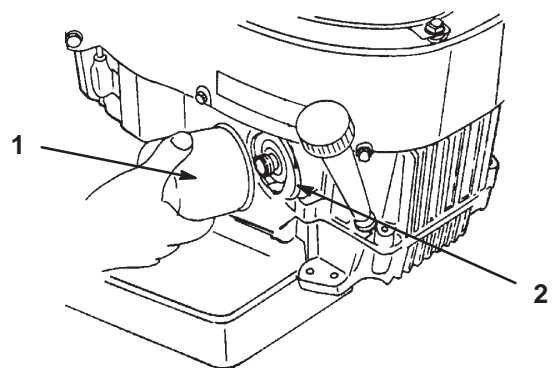

m-4288

**Figure 36**

- Oil filter
- Adapter

- Install the replacement oil filter to the adapter. Turn the oil filter clockwise until the rubber gasket contacts the filter adapter; then tighten the filter an additional 3/4 turn (Fig. 36).
- Fill the crankcase with the proper type of new oil; refer to Servicing the Engine Oil, page 30.

## Servicing the Spark Plug

Check the spark plug(s) after every 100 operating hours. Make sure that the air gap between the center and side electrodes is correct before installing the spark plug. Use a spark plug wrench for removing and installing the spark plug(s) and a gapping tool/feeler gauge to check and adjust the air gap. Install a new spark plug(s) if necessary.

Type: NGK BPR5ES (or equivalent)

Air Gap: 0.030 in. (0.76 mm)

### Removing the Spark Plug(s)

1. Disengage the power take off (PTO), set the parking brake, stop the engine, and remove the key.
2. Pull the wire(s) off of the spark plug(s) (Fig. 37). Clean around the spark plug(s) to prevent dirt from falling into the engine and potentially causing damage.
3. Remove the spark plug(s).

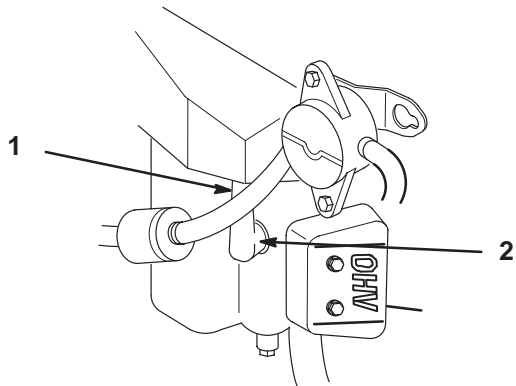

Figure 37

1. Spark plug wire installed
2. Spark plug

m-4294

## Checking the Spark Plug

Clean or replace the spark plug and set the gap every 100 hours.

1. Look at the center of the spark plug(s) (Fig. 38). If you see light brown or gray on the insulator, the engine is operating properly. A black coating on the insulator usually means the air cleaner is dirty.

**Important** Always replace the spark plug(s) when it has a black coating, worn electrodes, an oily film, or cracks.

2. Clean the electrode by scraping or with a wire brush to remove carbon deposits and wetness.
3. Check the gap between the center and side electrodes (Fig. 38). Bend the side electrode (Fig. 38) if the gap is not correct.

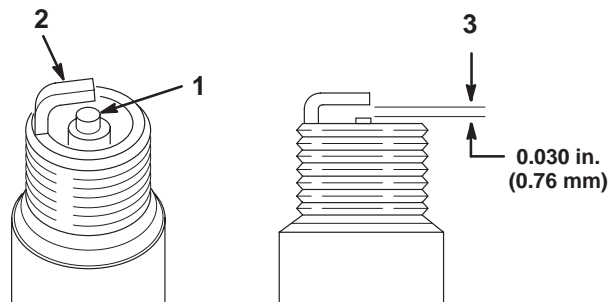

m-3215

Figure 38

1. Center electrode insulator
2. Side electrode
3. Air gap (not to scale)

### Installing the Spark Plug(s)

1. Install the spark plug(s). Make sure that the air gap is set correctly.
2. Tighten the spark plug(s) to 16 ft.-lb. (22 N·m).
3. Push the wire(s) onto the spark plug(s) (Fig. 37).



## Replacing the Fuel Filter

Replace the fuel filter after every 200 operating hours or yearly, whichever occurs first.

Never install a dirty filter if it is removed from the fuel line.

1. Disengage the power take off (PTO), set the parking brake, stop the engine, and remove the key.
2. Close the fuel shut-off valve on the console.
3. Squeeze the ends of the hose clamps together and slide them away from the filter (Fig. 39).
4. Remove the filter from the fuel lines.
5. Install a new filter and move the hose clamps close to the filter (Fig. 40).
6. Open the fuel shut-off valve on the console.

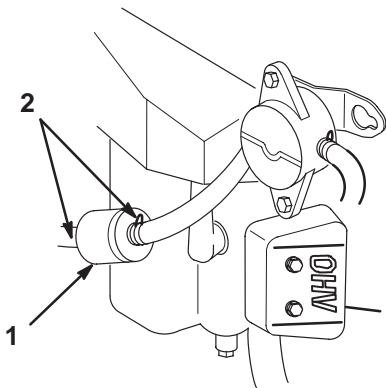

Figure 39

1. Filter
2. Hose clamp

M-4294

2. Close the fuel shut-off valve (Fig. 40).
3. Loosen the hose clamp at the fuel filter and slide it up the fuel line away from the fuel filter (Fig. 40).
4. Pull the fuel line off of the fuel filter (Fig. 40).
5. Open the fuel shut-off valve for the left and right tanks. Allow gasoline to drain into a gas can or drain pan (Fig. 40).

**Note:** Now is the best time to install a new fuel filter because the fuel tank is empty.

6. Install the fuel line onto the fuel filter. Slide the hose clamp close to the fuel filter to secure the fuel line (Fig. 40).

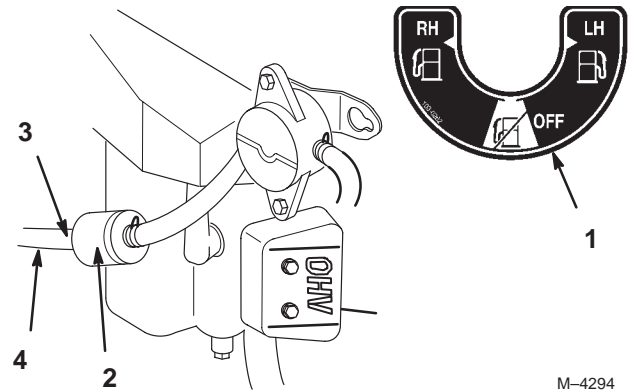

Figure 40

1. Fuel shut-off valve
2. Fuel filter
3. Hose clamp
4. Fuel line

M-4294

## Draining the Fuel Tank

⚠
Danger
⚠

**In certain conditions, gasoline is extremely flammable and highly explosive. A fire or explosion from gasoline can burn you and others and can damage property.**

- **Drain gasoline from the fuel tank when the engine is cold. Do this outdoors in an open area. Wipe up any gasoline that spills.**
- **Never smoke when draining gasoline, and stay away from an open flame or where a spark may ignite the gasoline fumes.**

1. Park the machine on a level surface to ensure that the fuel tanks drain completely. Then disengage the power take off (PTO), set the parking brake, stop the engine, and remove the key.

## Servicing the Spark Arrester

Inspect the spark arrester every 50 hours for damage, such as holes in the screen, and for buildup on the screen. If it is damaged, replace it with a new spark arrester. If it is dirty, remove it and clean the screen with a wire brush and/or soak it in solvent.

# Greasing and Lubrication

Lubricate the machine when shown on the **Check Service Reference Aid** decal (Fig. 41). Grease more frequently when operating conditions are extremely dusty or sandy.

Grease with No. 2 general purpose lithium base or molybdenum base grease.

## How to Grease

1. Disengage the power take off (PTO), stop the engine, and remove the key.
2. Clean the grease fittings with a rag. Make sure to scrape any paint off of the front of the fitting(s).
3. Connect a grease gun to the fitting. Pump grease into the fittings until grease begins to ooze out of the bearings.
4. Wipe up any excess grease.

## Where to Add Grease

Lubricate the grease fittings as shown on the **Check Service Reference Aid** decal (Fig. 41).

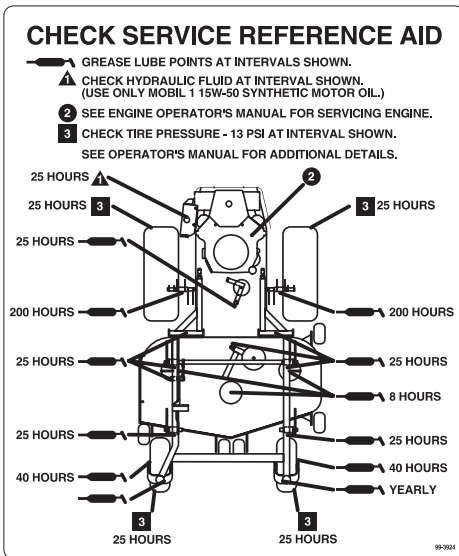

Figure 41

## Greasing the Front Castor Pivots

Lubricate the front castor pivots once a year.

1. Remove the hex plug and cap. Thread a grease zerk into the hole.
2. Pump grease into the zerk until it oozes out around the top bearing.
3. Remove the grease zerk in the hole. Install the hex plug and cap.

## Greasing the Bearings

The cutting unit must be lubricated regularly; refer to the Recommended Maintenance Schedule, page 26. Grease with No. 2 general purpose lithium base or molybdenum base grease.

1. Stop the engine, set the parking brake, remove the key and disconnect the spark plug wire(s) from the spark plug(s).
2. Grease the fittings on the three spindle bearings (Fig. 42).
3. Grease the idler pulley pivot (Fig. 42).
4. Grease the fittings on the push arms (Fig. 42).

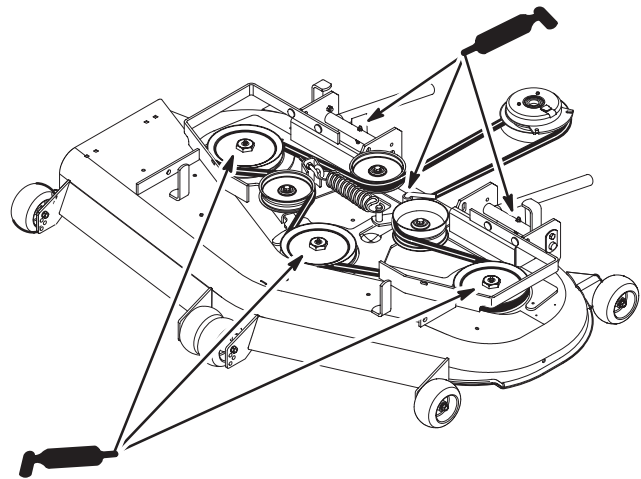

Figure 42

## Where to Add Light Oil or Spray Lubrication

Lubricate the machine in the following areas with spray type lubricant or light oil. Lubricate every 160 hours.

- Seat switch actuator
- Brake handle pivot
- Brake rod bushings
- Motion control bronze bushings

## Checking the Tire Pressure

Maintain the air pressure in the front and rear tires as specified. Uneven tire pressure can cause uneven cut. Check the pressure at the valve stem after every 50 operating hours or monthly, whichever occurs first (Fig. 43). Check the tires when they are cold to get the most accurate pressure reading.

Pressure: 13 psi (90 kPa) drive wheels and castor wheels

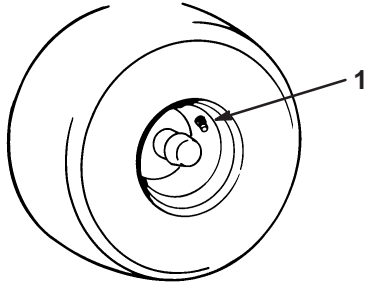

m-1872

Figure 43

1. Valve stem

## Servicing the Hydraulic System

### Checking the Hydraulic Fluid

Check the hydraulic fluid level before engine is first started.

Check the hydraulic fluid level after first 8 operating hours.

Check the hydraulic fluid level after every 25 operating hours.

Fluid Type: Mobil 1 15W-50 synthetic motor oil or equivalent synthetic oil.

**Important** Use the oil specified or equivalent. Other fluids could cause system damage.

Hydraulic System Oil Capacity: 67 oz. (2 l)

**Note:** There are two ways of checking the hydraulic oil. One is when the oil is warm and one is when the oil is cold. The baffle inside the tank has two levels depending if the oil is warm or cold.

1. Position the machine on a level surface and set the parking brake.
2. Clean the area around the filler neck of the hydraulic tank (Fig. 44).
3. Remove the cap from the filler neck. Look inside to check if there is fluid in the reservoir (Fig. 44).
4. If there is no fluid, add fluid to the reservoir until it reaches the *cold* level of the baffle.

5. Run the machine at low idle for 15 minutes to allow any air to purge out of the system and warm the fluid; refer to Starting and Stopping the Engine, page 18.

6. Recheck the fluid level while the fluid is warm. If required, add fluid to the reservoir until it reaches the *hot* level of the baffle.

**Note:** The fluid level should be to the top of the *hot* level of the baffle, when the fluid is warm (Fig. 44).

7. Install the cap on the filler neck.

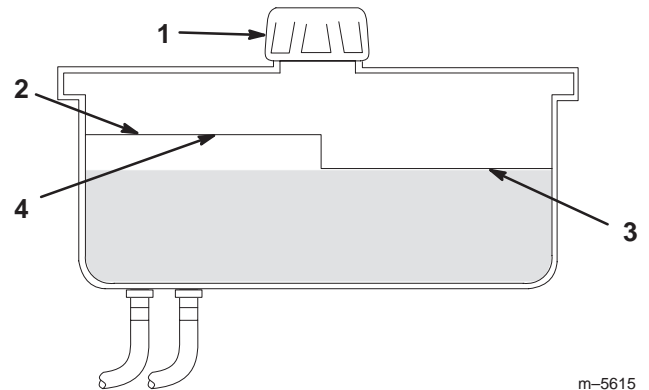

m-5615

Figure 44

1. Cap
2. Baffle
3. Cold fluid level—full
4. Hot fluid level—full



### Warning



**Hydraulic fluid escaping under pressure can penetrate skin and cause injury.**

- If hydraulic fluid is injected into the skin it must be surgically removed within a few hours by a doctor familiar with this type of injury. Gangrene may result if this is not done.
- Keep body and hands away from pin hole leaks or nozzles that eject high pressure hydraulic fluid.
- Use cardboard or paper to find hydraulic leaks.
- Safely relieve all pressure in the hydraulic system before performing any work on the hydraulic system.
- Make sure all hydraulic fluid hoses and lines are in good condition and all hydraulic connections and fittings are tight before applying pressure to hydraulic system.

## Replacing the Hydraulic Filter

Change the hydraulic filter:

- After the first 8 operating hours.
  - After every 200 operating hours.
1. Position machine on a level surface, stop the engine, and remove the key.

**Important** Do not substitute with an automotive oil filter or severe hydraulic system damage may result.

2. Remove the hydro cap and temporarily cover the opening with a plastic bag and rubber band to prevent all hydro fluid from draining out.
3. Place a drain pan under the filter, remove the old filter, and wipe the filter adapter gasket surface clean (Fig. 45).

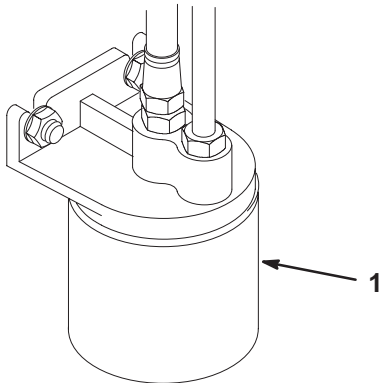
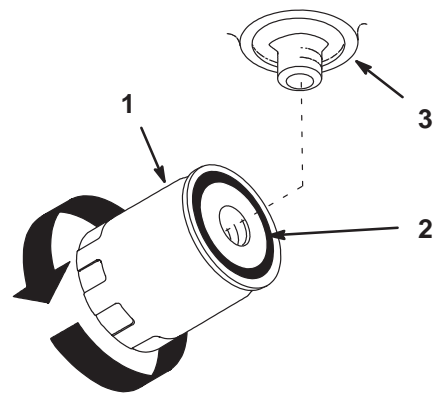

Figure 45

m-4117

1. Hydraulic filter

4. Apply a thin coat of hydro fluid to the rubber gasket on the replacement filter (Fig. 46).
5. Install the replacement hydraulic filter onto the filter adapter. Do not tighten.
6. Remove the plastic bag from the tank opening and allow the filter to fill with hydro fluid.
7. When fluid overflows the filter, turn the oil filter clockwise until the rubber gasket contacts the filter adapter; then tighten the filter an additional 1/2 turn (Fig. 46).
8. If there is no fluid, add fluid to the reservoir to approximately 1/4 in. (6 mm) below the top of the baffle.



m-1256

Figure 46

1. Hydraulic filter
2. Gasket
3. Adapter

9. Clean up any spilled fluid.

10. Start the engine and let it run for about two minutes to purge air from the system. Stop the engine and check for leaks. If one or both wheels will not drive, refer Bleeding the Hydraulic System, page 36.

11. Check the fluid level in the hydraulic tank while the fluid is warm. Add fluid to raise the level to the top of the baffle, if required. **Do not overfill.**

## Bleeding the Hydraulic System

The traction system is self bleeding; however, it may be necessary to bleed the system if the fluid is changed or after work is performed on the system.

1. Raise the rear of the machine so that the wheels are off of the ground and support it with jack stands.
2. Start the engine and run it at idle speed. Engage the traction on one side and spin the wheel by hand.
3. When the wheel begins to spin on its own, keep it engaged until the wheel drives smoothly (minimum 2 minutes).
4. Check the hydraulic fluid level as it drops and add as required to maintain the proper level.
5. Repeat this procedure on the opposite wheel.

## Checking the Hydraulic Lines

After every 100 operating hours, check the hydraulic lines and hoses for leaks, loose fittings, kinked lines, loose mounting supports, wear, weather and chemical deterioration. Make necessary repairs before operating.

**Note:** Keep the areas around the hydraulic system clean from grass and debris buildup.

⚠Warning⚠

**Hydraulic fluid escaping under pressure can penetrate skin and cause injury.**

- **If hydraulic fluid is injected into the skin it must be surgically removed within a few hours by a doctor familiar with this type of injury. Gangrene may result if this is not done.**
- **Keep body and hands away from pin hole leaks or nozzles that eject high pressure hydraulic fluid.**
- **Use cardboard or paper to find hydraulic leaks.**
- **Safely relieve all pressure in the hydraulic system before performing any work on the hydraulic system.**
- **Make sure all hydraulic fluid hoses and lines are in good condition and all hydraulic connections and fittings are tight before applying pressure to hydraulic system.**

## Adjusting the Motion Controls

### Adjusting the Handle Neutral

If the motion control levers do not align, or move easily into the console notch, an adjustment is required. Adjust each lever, spring, and rod separately.

**Note:** The motion control levers must be installed correctly; refer to Installing the Motion Control Levers, page 15.

1. Stop the engine, remove the ignition key, and tilt the seat forward.
2. Begin with either the left or right motion control lever. Move the lever to the neutral (but not locked) position and pull the lever back until the clevis pin (on the arm below the pivot shaft) contacts the end of the slot (just beginning to put pressure on the spring) (Fig. 47).

3. Check where the lever is relative to the notch in the console. It should be centered allowing the lever to pivot outward to the neutral lock position (Fig. 47).
4. If an adjustment is needed, loosen the nut against the yoke.
5. Apply slight rearward pressure on the motion control lever and turn the head of the adjustment bolt in the appropriate direction until the lever is centered in the neutral lock position (keeping rearward pressure on the lever will keep the pin at the end of the slot and allow the adjustment bolt to move the lever to the appropriate position).
6. Tighten the nut and jam nut.
7. Repeat on the opposite side of the unit.

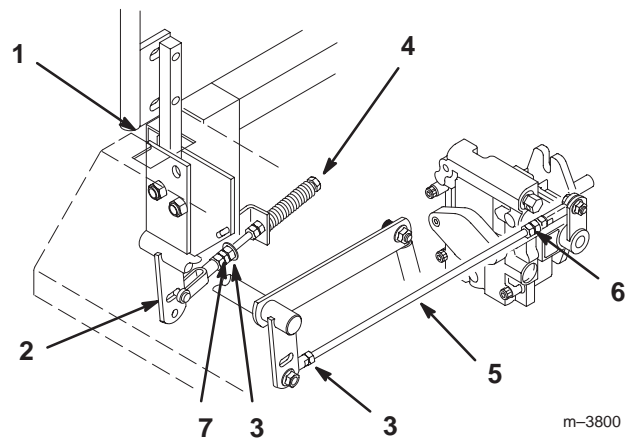

**Figure 47**

- |                          |                |
|--------------------------|----------------|
| 1. Neutral lock position | 5. Pump rod    |
| 2. Clevis pin in slot    | 6. Double nuts |
| 3. Nut                   | 7. Jam nut     |
| 4. Bolt                  |                |

### Adjusting the Hydraulic Pump Neutral

**Note:** Adjust the handle neutral first. That has to be correct before the following adjustment can be made.

⚠Danger⚠

**Mechanical or hydraulic jacks may fail to support machine and cause a serious injury.**

- **Use jack stand when supporting machine.**
- **Do not use hydraulic jacks.**

1. This adjustment must be made with the drive wheels turning. First raise the frame and block it up so that the drive wheels can rotate freely.

**Warning**

**Engine must be running so motion control adjustment can be performed. Contact with moving parts or hot surfaces may cause personal injury.**

**Keep hands, feet, face, clothing and other body parts away from rotating parts, muffler and other hot surfaces.**

2. Slide the seat forward, disconnect the prop rod, and tilt the seat fully forward.
3. Disconnect the electrical connector from the seat safety switch. *Temporarily* install a jumper wire across the terminals in the wiring harness connector.
4. Loosen the locknut at the ball joint on the pump control rod (Fig. 47).

**Note:** The front nut of each rod has left-hand threads.

5. Start the engine, open the throttle 1/2 way, and release the parking brake; refer to Starting and Stopping the Engine, page 18.
6. Adjust the pump rod length by rotating the double nuts on the rod, in the appropriate direction, until the wheel is still or slightly creeps in reverse (Fig. 47).
7. Move the motion control lever forward and reverse, then back to neutral. The wheel must stop turning or slightly creep in reverse.

**Note:** The motion control lever must be in neutral while making any adjustments.

8. Open the throttle to fast. Make sure that the wheel remains stopped or slightly creeps in reverse. Readjust if necessary.
9. Repeat on the opposite side of the unit. Tighten the locknuts against the ball joints.

**Warning**

**Electrical system will not perform proper safety shut off with jumper wire installed.**

- **Remove jumper wire from wire harness connector and plug connector into seat switch when adjustment is completed.**
- **Never operate this unit with jumper installed and seat switch bypassed.**

10. Shut off the unit. Remove the jumper wire from the wire harness connector and plug the connector into the seat switch.
11. Install the prop rod and lower the seat.

## Adjusting the Castor Pivot Bearing

Check after every 500 operating hours or at storage, whichever occurs first.

1. Stop the engine, set the parking brake, remove the key, and disconnect the spark plug wire(s) from the spark plug(s).
2. Remove the dust cap from the castor and tighten the locknut (Fig. 48).
3. Tighten until the spring washers are flat and then back off 1/4 turn to properly set the preload on the bearings (Fig. 48).

**Important** Make sure that the spring washers are installed correctly as shown in Figure 48.

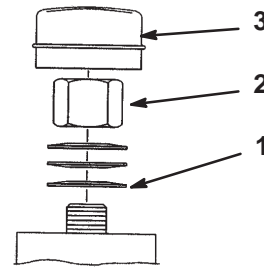

**Figure 48**

1. Spring washers
2. Locknut
3. Dust cap

m-4640



## Checking the Wheel Hub Slotted Nut

Check after every 500 operating hours.

The slotted nut needs to be torqued to 125 ft.-lb. (170 N·m).

1. Stop the engine, set the parking brake, remove the key, and disconnect the spark plug wire(s) from the spark plug(s).
2. Remove the cotter pin.
3. Torque the slotted nut to 125 ft.-lb. (170 N·m) (Fig. 49).
4. Check the distance from the bottom of the slot in the nut to the inside edge of the hole. Two threads or less should be showing (Fig. 49).
5. If more than two threads are showing, remove the nut and install a washer between the hub and nut (Fig. 49).
6. Torque the slotted nut to 125 ft.-lb. (170 N·m) (Fig. 49).
7. Tighten the nut until the next set of slots line up with the hole in the shaft (Fig. 49).
8. Install the cotter pin.

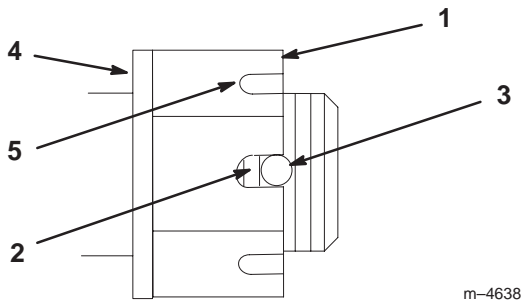

Figure 49

- |                                |                           |
|--------------------------------|---------------------------|
| 1. Slotted nut                 | 3. Hole in threaded shaft |
| 2. Two threads or less showing | 4. Washer (if needed)     |
|                                | 5. Slot                   |

## Adjusting the Mower Level

1. Position the mower on a flat surface. Stop the engine, set the parking brake, remove the key, and disconnect the spark plug wire(s) from the spark plug(s).
2. Check the tire pressure of all 4 tires. If needed, adjust to 13 psi (90 kPa).
3. Set the anti-scalp rollers to the top holes or remove them completely for this adjustment.

4. Raise the deck to the transport position (Fig. 50). Take force off of the two large deck lift springs by loosening the jam nut and front spring nut, in front of each spring, as far as possible (Fig. 51).
5. Place 2 thick blocks (1-1/4 in. [35 mm]) under the rear left and right lower edge of the mower. Place 1 block (1-3/8 in. [44 mm]) under the front center lower edge of the mower, not under the anti-scalp roller brackets. Lower the mower to the 1-1/2 in. (38 mm) height-of-cut position (Fig. 50).

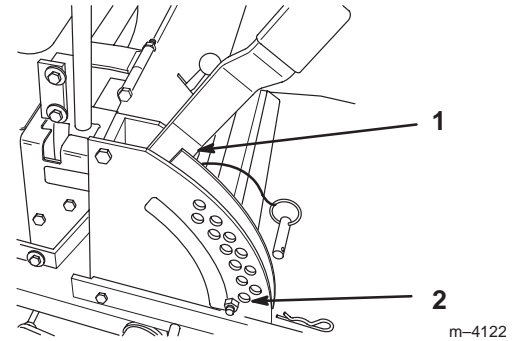

Figure 50

- |                       |                                    |
|-----------------------|------------------------------------|
| 1. Transport position | 2. 1-1/2 in. (38 mm) height-of-cut |
|-----------------------|------------------------------------|

6. Loosen the bottom chain bolt in the slot at the rear of the deck. Repeat for the opposite side (Fig. 51).

**Note:** Do not loosen the front chain hardware.

7. Loosen the front and rear locking nut on either side of the front swivel. Loosen until the front chains are loose and the deck is supported by blocks. Repeat for the opposite side. (Fig. 51).

**Note:** When the hardware is loose, the deck will rotate the lift handle up, out of position.

8. When the hardware is loosened, the remaining tension in the large support springs will tend to rotate the deck lift handle up, out of the 1-1/2 in. (38 mm) position. Press down on the rear deck support arm to firmly return the deck lift handle to the 1-1/2 in. (38 mm) position (Fig. 51).

**Note:** Do not push on the deck lift handle.

9. While continuing to press down on the rear deck support arm, take the slack out of the rear chain and tighten the hardware at the bottom (Fig. 51). Downward pressure may now be released. Repeat for the opposite side.

- Adjust the front swivel using the rear locking nut until the front chain is tight and the front of the deck is still touching the block. Tighten the front locking nut. Repeat for the opposite side.

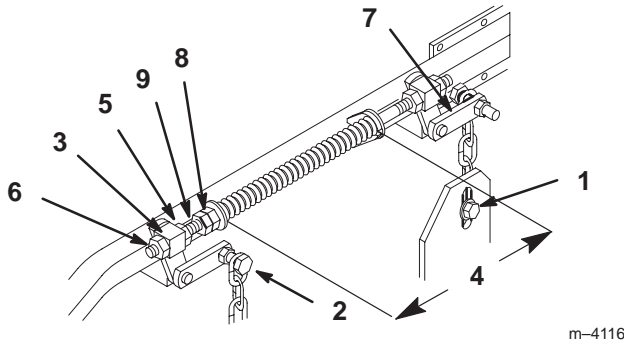

Figure 51

- |  |                          |
|--|--------------------------|
| 1. Bottom chain bolt                     | 5. Rear locking nut      |
| 2. Top chain bolt                        | 6. Front locking nut     |
| 3. Front swivel                          | 7. Rear deck support arm |
| 4. 10-1/4 in. (260 mm) spring compressed | 8. Front spring nut      |
|  | 9. Jam nut               |

- Recheck that the blocks fit just snugly under the mower and that the tension on all four chains are approximately equal.
- Raise the deck to the 3 in. (76 mm) height of cut and measure the actual height from the blade tips to the ground. The height of cut for the front blade tips should be  $3 \pm 1/8$  in. (76  $\pm$  3 mm). The height of cut for the rear blade tips should be  $3-1/4 \pm 1/8$  in. (83  $\pm$  3 mm). Readjust if needed.

**Note:** When checking the blade tip heights, make sure that the blades are not bent and check the blade pointing front to rear.

- Install anti-scalp rollers for proper height-of-cut and tighten them securely; refer to Adjusting the Anti-Scalp Rollers, page 21.
- Raise the deck lift lever to the transport position (Fig. 50).
- Adjust the compression springs by turning the front spring nuts so that the distance between the two large washers is 10-1/4 in. (260 mm); then tighten the jam nut (Fig. 51).

**Note:** Make sure that all hardware is tight.

## Adjusting the Push Arms

- To adjust the push arms, loosen the jam nut and rotate the ball joint counterclockwise, one turn at a time.(Fig. 52).

- Adjust each side the same amount. Each push arm should have a nominal length of 15-5/16 in. (389 mm) (Fig. 52).

**Note:** Increase the tension by lengthening the push arms and decrease the tension by shortening the push arms.

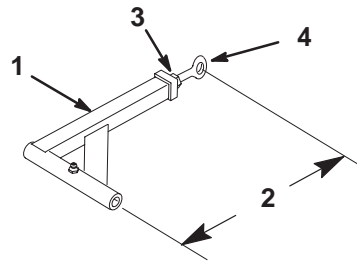

Figure 52

- |                                 |               |
|---------------------------------|---------------|
| 1. Push arm                     | 3. Jam nut    |
| 2. 15-5/16 in. (389 mm) nominal | 4. Ball joint |

## Cleaning Under the Deck

Remove grass build up under the deck daily.

- Position the mower on a flat surface. Stop the engine, set the parking brake, remove the key, and disconnect the spark plug wire(s) from the spark plug(s).
- Raise the deck to the transport position.
- Lift the front of the unit and support the unit using jack stands.

⚠
Danger
⚠

**Mechanical or hydraulic jacks may fail to support machine and cause a serious injury.**

- Use jack stand when supporting machine.
- Do not use hydraulic jacks.

## Inspecting the Belts

Inspect all belts every 100 hours.

Check belts for cracks, frayed edges, burn marks, or any other damage. Replace damaged belts.

## Replacing the Deck Belt

Squealing when the belt is rotating, blades slipping when cutting grass, frayed belt edges, burn marks, and cracks are signs of a worn deck belt. Replace the deck belt if any of these conditions are evident.



1. Stop the engine, set the parking brake, remove the key, and disconnect the spark plug wire(s) from the spark plug(s).
2. Remove the belt covers over the outside spindles.
3. Loosen the outer nut on the spring eye bolt (Fig. 53).

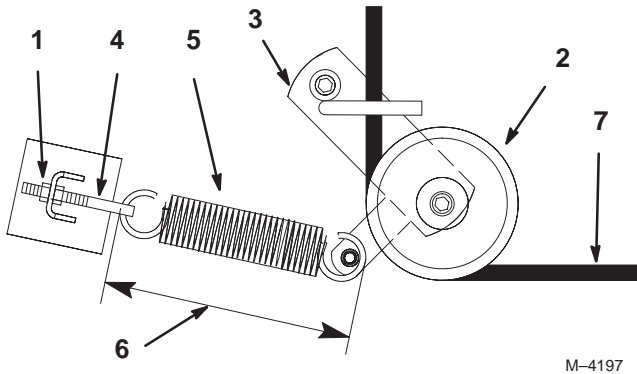

**Figure 53**

Top View

- |                    |                                    |
|--------------------|------------------------------------|
| 1. Outer nut       | 5. Spring                          |
| 2. Idler pulley    | 6. 9-3/8 ± 1/8 in.<br>(238 ± 3 mm) |
| 3. Idler arm       | 7. Deck belt                       |
| 4. Spring eye bolt |                                    |

4. Remove the belt. Start at the outside pulley and rotate the belt off (Fig. 54).

**Note:** Do not remove the spring from the eye bolt.

!
Caution
!

**Spring is under tension when installed and can cause personal injury.**

**Do not remove spring from spring eye bolt.**

5. Remove spring loaded idler pulley (Fig. 53).
6. Route the new belt through the idler arm (Fig. 53).
7. Install the idler pulley and route the belt onto the other pulleys (Fig. 54).
8. Tighten the outer nut on the spring eye bolt (Fig. 53).

**Note:** Check the spring length. The spring should measure 9-3/8 ± 1/8 in. (238 ± 3 mm) when installed. Adjust it if it does not (Fig. 53).

9. Install the belt covers over the outside spindles.

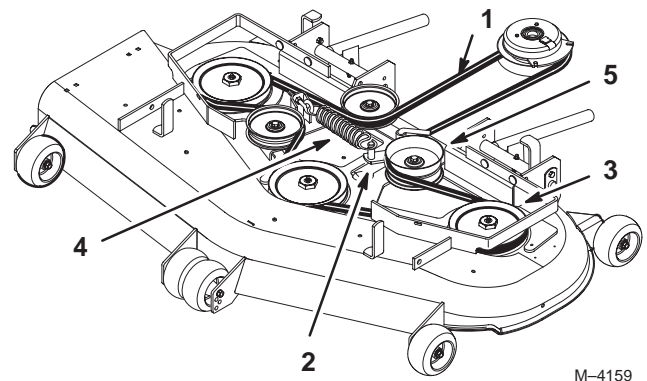

**Figure 54**

Top View

- |                   |                 |
|-------------------|-----------------|
| 1. Deck belt      | 4. Spring       |
| 2. Idler arm      | 5. Idler pulley |
| 3. Outside pulley |                 |

## Replacing the Pump Drive Belt

Check the pump drive belt for wear after every 50 hours of operation.

1. Remove the deck belt first; refer to Replacing the Deck Belt, page 40.
2. Remove the bolt from the clutch strap and unplug the clutch electrical wire (Fig. 55).
3. Pull the spring loaded idler to the side. Remove the traction belt from the engine and hydro pump pulleys (Fig. 55).
4. Install the new belt around the engine and hydro pump pulleys (Fig. 55).
5. Pull the spring loaded idler to the side and align the belt. Release pressure on the spring loaded idler (Fig. 55).
6. Install the deck belt.

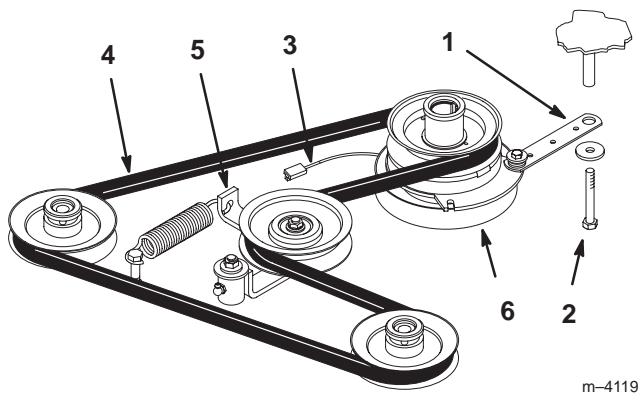

**Figure 55**

- |                           |           |
|---------------------------|-----------|
| 1. Clutch strap           | 4. Belt   |
| 2. Bolt                   | 5. Idler  |
| 3. Clutch electrical wire | 6. Clutch |

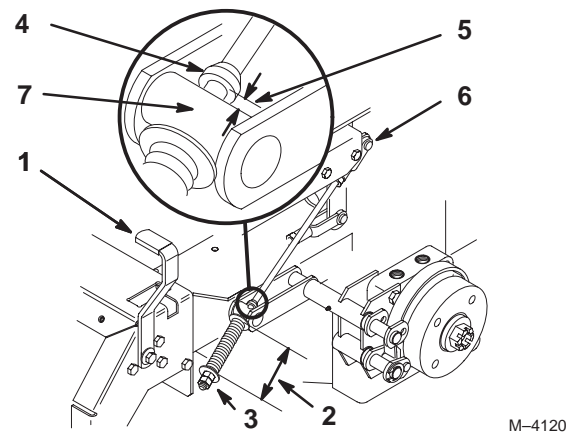

**Figure 56**

- |                              |                          |
|------------------------------|--------------------------|
| 1. Brake lever               | 5. 3/16-1/4 in. (5-7 mm) |
| 2. Spring, 2-3/4 in. (74 mm) | 6. Jam nut and yoke      |
| 3. Adjusting nuts            | 7. Trunnion              |
| 4. Collar on brake rod       |                          |

## Adjusting the Parking Brake

Check the parking brake for proper adjustment.

1. Disengage the brake lever (lever down).
2. Measure the length of the spring. The measurement should be 2-3/4 in. (74 mm) between the washers (Fig. 56).
3. If an adjustment is necessary, loosen the jam nut below the spring and tighten the nut directly below the yoke (Fig. 56). Turn the nut until the correct measurement is obtained. Tighten the two nuts together and repeat on the opposite side of the unit.
4. Turn the nuts clockwise to shorten the spring length and turn them counterclockwise to lengthen the spring.
5. Engage the parking brake, lever up.
6. Measure the distance between the trunnion roller and the collar on the brake rod. The measurement should be 3/16-1/4 in. (5-7 mm) (Fig. 56).
7. If an adjustment is necessary, loosen the jam nut directly below the yoke. Turn the bottom adjusting nuts until the correct measurement is obtained (Fig. 56). Tighten the jam nut at the yoke.

## Servicing the Fuses

The electrical system is protected by fuses. It requires no maintenance; however, if a fuse blows, check the component/circuit for a malfunction or short.

Fuse: Main F1—20 amp, blade-type  
Alternator F2—20 amp, blade-type

1. Raise the seat to gain access to the fuse holder (Fig. 57).
2. To replace the fuses, pull out on the fuse to remove it (Fig. 57).

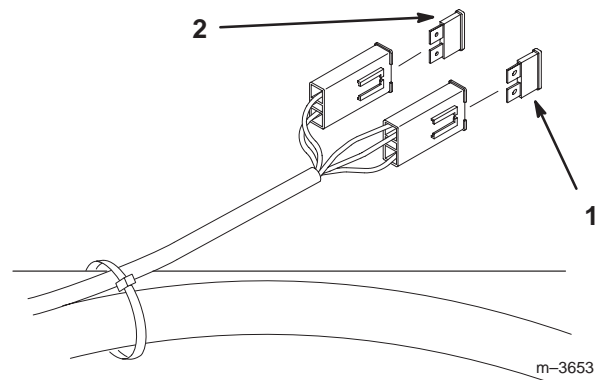

**Figure 57**

- |                |                      |
|----------------|----------------------|
| 1. Main—20 amp | 2. Alternator—20 amp |
|----------------|----------------------|

## Servicing the Battery

**Warning**

Battery posts, terminals, and related accessories contain lead and lead compounds, chemicals known to the State of California to cause cancer and reproductive harm. *Wash hands after handling.*

### Checking Electrolyte Level

1. With the engine off, open the hood to locate the battery.
2. Look at the side of the battery. The electrolyte must be up to the **upper** line (Fig. 58). Do not allow the electrolyte to get below the **lower** line (Fig. 58).
3. If the electrolyte is low, add the required amount of distilled water; refer to Adding Water to the Battery, page 44.

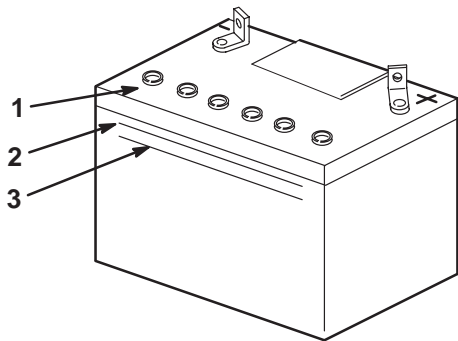

m-5004

**Figure 58**

1. Filler caps
2. **Upper** line
3. **Lower** line

**Danger**

Battery electrolyte contains sulfuric acid which is a deadly poison and causes severe burns.

- Do not drink electrolyte and avoid contact with skin, eyes or clothing. Wear safety glasses to shield your eyes and rubber gloves to protect your hands.
- Fill the battery where clean water is always available for flushing the skin.
- Follow all instructions and comply with all safety messages on the electrolyte container.

### Installing the Battery

1. Position battery in tray with terminal posts toward the engine (Fig. 59).
2. First, install the positive (red) battery cable to positive (+) battery terminal.
3. Then install negative battery cable and ground wire to the negative (-) battery terminal.
4. Secure cables with 2 bolts (1/4 x 3/4 in.), 2 washers (1/4 in.), and 2 locknuts (1/4 in.) (Fig. 59).
5. Slide the red terminal boot onto the positive (red) battery post.
6. Secure battery with J-bolts, hold down clamp and 2 washers (1/4 in.), and 2 wing nuts (1/4 in.) (Fig. 59).

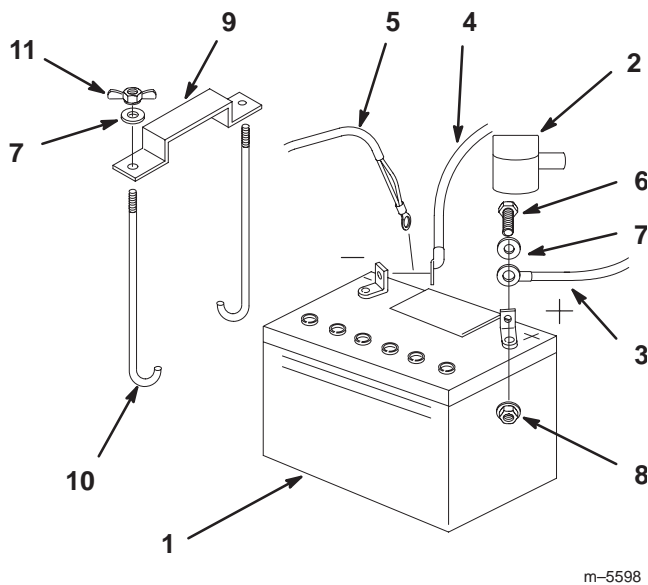

**Figure 59**

- |                           |                       |
|---------------------------|-----------------------|
| 1. Battery                | 7. Washer, 1/4 in.    |
| 2. Terminal boot          | 8. Locknut, 1/4 in.   |
| 3. Positive battery cable | 9. Battery clamp      |
| 4. Negative battery cable | 10. J-bolts           |
| 5. Ground wire            | 11. Wing nut, 1/4 in. |
| 6. Bolt, 1/4 x 3/4 in.    |                       |

## Removing the Battery



### Warning



**Battery terminals or metal tools could short against metal machine components causing sparks. Sparks can cause the battery gasses to explode, resulting in personal injury.**

- **When removing or installing the battery, do not allow the battery terminals to touch any metal parts of the machine.**
- **Do not allow metal tools to short between the battery terminals and metal parts of the machine.**



### Warning



**Incorrect battery cable routing could damage the machine and cables causing sparks. Sparks can cause the battery gasses to explode, resulting in personal injury.**

- **Always *Disconnect* the negative (black) battery cable before disconnecting the positive (red) cable.**
- **Always *Reconnect* the positive (red) battery cable before reconnecting the negative (black) cable .**

1. Disengage the power take off (PTO), set the parking brake, and turn the ignition key to off. Remove the key.
2. Tilt seat up.
3. First disconnect the negative battery cable and ground wire from the negative (-) battery terminal (Fig. 59).
4. Slide the red terminal boot off the positive (red) battery terminal. Then remove positive (red) battery cable (Fig. 59).
5. Remove both wing nuts (1/4 in.) securing the battery clamp (Fig. 59).
6. Remove the battery.

## Adding Water to the Battery

The best time to add distilled water to the battery is just before you operate the machine. This lets the water mix thoroughly with the electrolyte solution.

1. Remove the battery from the machine.
2. Clean the top of the battery with a paper towel.

**Note:** Never fill the battery with distilled water while the battery installed in the machine. Electrolyte could be spilled on other parts and cause corrosion.

3. Remove the vent caps from the battery (Fig. 58).
4. Slowly pour distilled water into each battery cell until the level is up to the **upper** line (Fig. 58) on the battery case.

**Important** Do not overfill the battery because electrolyte (sulfuric acid) can cause severe corrosion and damage to the chassis.

5. Wait five to ten minutes after filling the battery cells. Add distilled water, if necessary, until the electrolyte level is up to the **upper** line (Fig. 58) on the battery case.
6. Reinstall battery vent caps.

## Charging the Battery

**Warning**

Charging the battery produces gasses that can explode.

Never smoke near the battery and keep sparks and flames away from battery.

**Important** Always keep the battery fully charged (1.265 specific gravity). This is especially important to prevent battery damage when the temperature is below 32°F (0°C).

1. Remove the battery from the chassis; refer to Removing the Battery, page 44.
2. Check the electrolyte level; refer to Checking Electrolyte Level, page 43.
3. Make sure the filler caps are installed in battery. Charge battery for 10 to 15 minutes at 25 to 30 amps or 30 minutes at 4–6 amps.
4. When the battery is fully charged, unplug the charger from the electrical outlet, then disconnect the charger leads from the battery posts (Fig. 60).

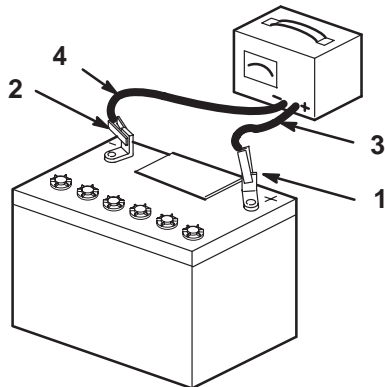

m-4970

**Figure 60**

- |                          |                           |
|--------------------------|---------------------------|
| 1. Positive Battery Post | 3. Red (+) Charger Lead   |
| 2. Negative Battery Post | 4. Black (-) Charger Lead |

5. Install the battery in the machine and connect the battery cables; refer to Installing the Battery on page 43.

**Note:** Do not run the machine with the battery disconnected, electrical damage may occur.

## Replacing the Grass Deflector

**Warning**

An uncovered discharge opening could allow the lawn mower to throw objects in the operator's or bystander's direction and result in serious injury. Also, contact with the blade could occur.

Never operate the lawn mower unless you install a cover plate, a mulch plate, or a grass chute and catcher.

1. Remove the locknut, bolt, spring, and spacer holding the deflector to the pivot brackets (Fig. 61). Remove the damaged or worn grass deflector.
2. Place the spacer and spring onto the grass deflector. Place the straight end of the spring behind the deck edge.

**Note:** Make sure that the straight end of the spring is installed behind the deck edge before installing the bolt as shown in Figure 61.

3. Install the bolt and nut. Place the hook end of the spring around the grass deflector (Fig. 61).

**Important** The grass deflector must be able to lower down into position. Lift the deflector up to test that it lowers into the full down position.

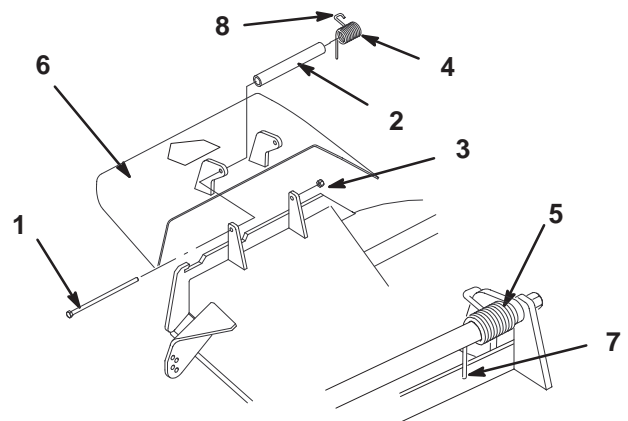

m-5037

**Figure 61**

- |                     |  |
|---------------------|--|
| 1. Bolt             | 6. Grass deflector                               |
| 2. Spacer           | 7. Place behind deck edge before installing bolt |
| 3. Locknut          | 8. Hook end of spring                            |
| 4. Spring           |  |
| 5. Spring installed |  |

## Waste Disposal

Engine oil, hydraulic oil, and engine coolant are pollutants to the environment. Dispose of these according to your state and local regulations.

## Mercury Tilt Switch

The tilt switch on this unit is located under the seat. Tilt the seat up to gain access.

The tilt switch on this unit contains mercury, a hazardous material. Mercury that is outside a sealed container vaporizes at room temperature. The vapors are harmful. Mercury can be absorbed through the skin. Do not attempt to open or repair this switch.

A very small amount of mercury is contained in a hermetically sealed body. The steel switch is then potted in a hard epoxy in a plastic case. It is unlikely that the mercury will ever escape from the enclosure. These high performance and reliable inexpensive switches are recyclable.

Mercury is an important and beneficial compound but requires special care in handling and disposal. When used and managed properly, mercury is not a threat to people or the environment. This information is presented to users so that they are aware that these switches contain mercury and will apply sound disposal practices when these devices reach their normal end of life or are damaged.

## Mercury Tilt Switch Disposal

Several states have passed laws concerning the disposal of devices containing mercury. In all the remaining states it is advisable to follow similar procedures. The laws state that these sealed devices contain mercury and should not be placed in the garbage until the mercury is removed and reused, recycled, or otherwise managed to ensure that it does not become part of solid waste or waters. Management and disposal practices must be within relevant federal, state, or local laws.

Return the switch to your Toro dealer if it is faulty and is being replaced or if the unit containing the switch is no longer operating and is being scrapped. If the switch is damaged or broken open, use extreme caution in handling. Call your local waste management authority or Toro Customer Service for instructions.



### Caution



**The mercury contained in the tilt switch is poisonous and exposure to mercury can cause severe illness.**

- **Never attempt to open or repair the tilt switch.**
- **Avoid contact with the mercury.**

# Wiring Diagram

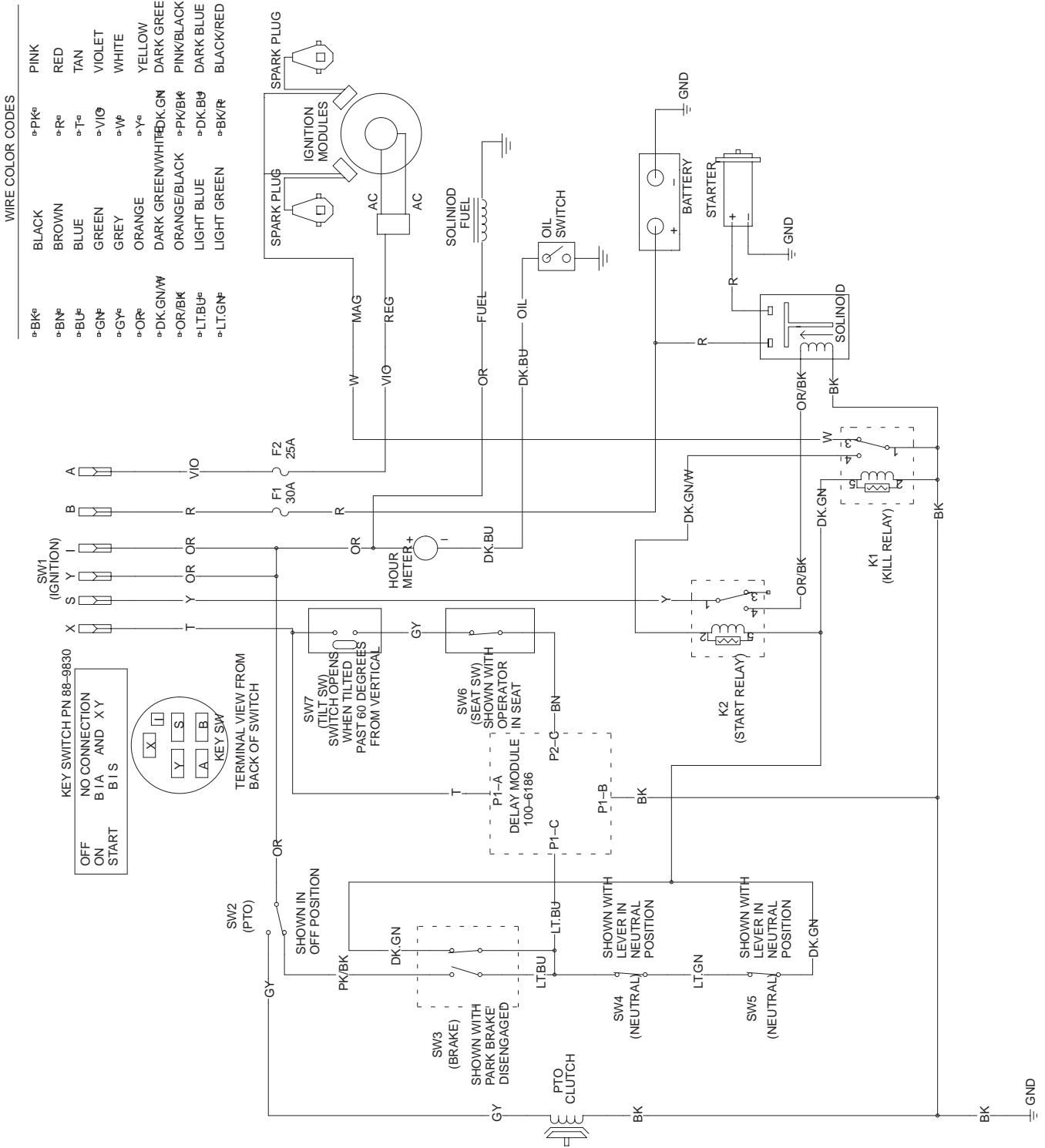



## Cleaning and Storage

1. Disengage the power take off (PTO), set the parking brake and turn the ignition key to off. Remove spark plug wire. Remove the key.
2. Remove grass clippings, dirt, and grime from the external parts of the entire machine, especially the engine and hydraulic system. Clean dirt and chaff from the outside of the engine's cylinder head fins and blower housing.

**Important** You can wash the machine with mild detergent and water. Do not pressure wash the machine. Avoid excessive use of water, especially near the control panel, engine, hydraulic pumps and motors.

3. Service the air cleaner; refer to Servicing the Air Cleaner, page 29.
4. Grease and oil the machine; refer to Greasing and Lubrication, page 34.
5. Change the crankcase oil and filter; refer to Servicing the Engine Oil, page 30.
6. Change the hydraulic filter; refer to Servicing the Hydraulic System, page 35.
7. Check the tire pressure; refer to Checking the Tire Pressure, page 35.
8. Charge the battery; refer to Servicing the Battery page 43.
9. Scrape any heavy buildup of grass and dirt from the underside of the mower, then wash the mower with a garden hose.
10. Check the condition of the blades. Refer to Servicing the Cutting Blades on page 27.
11. Prepare the machine for storage when non-use occurs over 30 days. Prepare machine for storage as follows.

- A. Add a petroleum based stabilizer/conditioner to fuel in the tank. Follow mixing instructions from stabilizer manufacture. **Do not use an alcohol based stabilizer (ethanol or methanol).**

**Note:** A fuel stabilizer/conditioner is most effective when mixed with fresh gasoline and used at all times.

- B. Run engine to distribute conditioned fuel through the fuel system (5 minutes).
- C. Stop engine, allow to cool and drain the fuel tank; refer to Servicing the Fuel Tank, page 33.
- D. Restart engine and run it until it stops.
- E. Choke or prime the engine. Start and run engine until it will not start. Operate primer, if equipped on machine, several times to ensure fuel remains in primer system.
- F. Dispose of fuel properly. Recycle as per local codes.

**Important** Do not store stabilizer/conditioned gasoline over 90 days.

12. Remove the spark plug(s) and check its condition; refer to Servicing the Spark Plug, page 32. With the spark plug(s) removed from the engine, pour two tablespoons of engine oil into the spark plug hole. Now use the starter to crank the engine and distribute the oil inside the cylinder. Install the spark plug(s). Do not install the wire on the spark plug(s).
13. Check and tighten all bolts, nuts, and screws. Repair or replace any part that is damaged or defective.
14. Paint all scratched or bare metal surfaces. Paint is available from your Authorized Service Dealer.
15. Store the machine in a clean, dry garage or storage area. Remove the key from the ignition switch and keep it in a memorable place out of reach of children or other unauthorized users. Cover the machine to protect it and keep it clean.



# Troubleshooting

Problem	Possible Causes	Corrective Action
Starter does not crank.	<ol style="list-style-type: none"> <li>1. Blade control (PTO) is engaged.</li> <li>2. Parking brake is not on.</li> <li>3. Operator is not seated.</li> <li>4. Battery is dead.</li> <li>5. Electrical connections are corroded or loose.</li> <li>6. Fuse is blown.</li> <li>7. Relay or switch is defective.</li> </ol>	<ol style="list-style-type: none"> <li>1. Move blade control (PTO) to <b>Disengaged</b>.</li> <li>2. Set parking brake.</li> <li>3. Sit on the seat.</li> <li>4. Charge the battery.</li> <li>5. Check electrical connections for good contact.</li> <li>6. Replace fuse.</li> <li>7. Contact Authorized Service Dealer.</li> </ol>
Engine will not start, starts hard, or fails to keep running.	<ol style="list-style-type: none"> <li>1. Fuel tank is empty.</li> <li>2. Fuel valve turned off.</li> <li>3. Choke is not on.</li> <li>4. Air cleaner is dirty.</li> <li>5. Spark plug wires are loose or disconnected.</li> <li>6. Spark plugs are pitted, fouled, or gap is incorrect.</li> <li>7. Dirt in fuel filter.</li> <li>8. Dirt, water, or stale fuel is in fuel system.</li> </ol>	<ol style="list-style-type: none"> <li>1. Fill fuel tank with gasoline.</li> <li>2. Open fuel valve.</li> <li>3. Move choke lever to on.</li> <li>4. Clean or replace air cleaner element.</li> <li>5. Install wires on spark plug.</li> <li>6. Install new, correctly gapped spark plugs.</li> <li>7. Replace fuel filter.</li> <li>8. Contact Authorized Service Dealer.</li> </ol>
Engine loses power.	<ol style="list-style-type: none"> <li>1. Engine load is excessive.</li> <li>2. Air cleaner is dirty.</li> <li>3. Oil level in crankcase is low.</li> <li>4. Cooling fins and air passages under engine blower housing are plugged.</li> <li>5. Spark plugs are pitted, fouled, or gap is incorrect.</li> <li>6. Vent in fuel cap is closed.</li> <li>7. Dirt in fuel filter.</li> <li>8. Dirt, water, or stale fuel is in fuel system.</li> </ol>	<ol style="list-style-type: none"> <li>1. Reduce ground speed.</li> <li>2. Clean air cleaner element.</li> <li>3. Add oil to crankcase.</li> <li>4. Remove obstruction from cooling fins and air passages.</li> <li>5. Install new, correctly gapped spark plugs.</li> <li>6. Open vent in fuel cap.</li> <li>7. Replace fuel filter.</li> <li>8. Contact Authorized Service Dealer.</li> </ol>
Engine overheats.	<ol style="list-style-type: none"> <li>1. Engine load is excessive.</li> <li>2. Oil level in crankcase is low.</li> <li>3. Cooling fins and air passages under engine blower housing are plugged.</li> </ol>	<ol style="list-style-type: none"> <li>1. Reduce ground speed.</li> <li>2. Add oil to crankcase.</li> <li>3. Remove obstruction from cooling fins and air passages.</li> </ol>

<b>Problem</b>	<b>Possible Causes</b>	<b>Corrective Action</b>
Machine does not drive.	<ol style="list-style-type: none"> <li>1. Traction belt is worn, loose or broken.</li> <li>2. Traction belt is off pulley.</li> <li>3. Hydro fluid level low.</li> </ol>	<ol style="list-style-type: none"> <li>1. Contact Authorized Service Dealer.</li> <li>2. Contact Authorized Service Dealer.</li> <li>3. Add hydro fluid to reservoir.</li> </ol>
Abnormal vibration.	<ol style="list-style-type: none"> <li>1. Engine mounting bolts are loose.</li> <li>2. Loose engine pulley, idler pulley, or blade pulley.</li> <li>3. Engine pulley is damaged.</li> <li>4. Cutting blade(s) is/are bent or unbalanced.</li> <li>5. Blade mounting bolt is loose.</li> <li>6. Engine mounting bolts are loose.</li> <li>7. Loose engine pulley, idler pulley, or blade pulley.</li> <li>8. Engine pulley is damaged.</li> <li>9. Blade spindle bent.</li> </ol>	<ol style="list-style-type: none"> <li>1. Tighten engine mounting bolts.</li> <li>2. Tighten the appropriate pulley.</li> <li>3. Contact Authorized Service Dealer.</li> <li>4. Install new cutting blade(s).</li> <li>5. Tighten blade mounting bolt.</li> <li>6. Tighten engine mounting bolts.</li> <li>7. Tighten the appropriate pulley.</li> <li>8. Contact Authorized Service Dealer.</li> <li>9. Contact Authorized Service Dealer.</li> </ol>
Uneven cutting height.	<ol style="list-style-type: none"> <li>1. Blade(s) not sharp.</li> <li>2. Cutting blade(s) is/are bent.</li> <li>3. Mower is not level.</li> <li>4. Gage wheel not set correctly.</li> <li>5. Underside of mower is dirty.</li> <li>6. Tire pressure is incorrect.</li> <li>7. Blade spindle bent.</li> </ol>	<ol style="list-style-type: none"> <li>1. Sharpen blade(s).</li> <li>2. Install new cutting blade(s).</li> <li>3. Level mower from side-to-side and front-to-rear.</li> <li>4. Adjust gage wheel height.</li> <li>5. Clean the underside of the mower.</li> <li>6. Adjust tire pressure.</li> <li>7. Contact Authorized Service Dealer.</li> </ol>
Blades do not rotate.	<ol style="list-style-type: none"> <li>1. Drive belt is worn, loose or broken.</li> <li>2. Drive belt is off pulley.</li> <li>3. Deck belt is worn, loose or broken.</li> </ol>	<ol style="list-style-type: none"> <li>1. Install new drive belt.</li> <li>2. Install drive belt and check adjusting shafts and belt guides for correct position.</li> <li>3. Install new deck belt.</li> </ol>





LCE

# The Toro Total Coverage Guarantee

## A One-Year Limited Warranty

### Conditions and Products Covered

The Toro Company and its affiliate, Toro Warranty Company, pursuant to an agreement between them, jointly promise to repair any Toro Product used for commercial, institutional, or rental purposes if defective in materials or workmanship. The following time periods apply from the date of purchase:

<u>Products</u>	<u>Warranty Period</u>
• All Products	1 year
• All Spindles	2 years parts and labor; third year, parts only
• Engines/Hydraulic Systems* on the following: Outfront and Mid-Mount Z's ProLine Mid-Size Mowers Groundsmaster® Riding Mowers Backpack Blowers	2 years
• Deck Shells (36"–72") on the following: ProLine Mid-Size Mowers Mid-Mount Z's	2 years
• Electric Clutch on 200 Series Mid-Mount Z's	2 years

This warranty includes the cost of parts and labor, but you must pay transportation costs.

This warranty applies to:

- Outfront and Mid-Mount Z's
- ProLine Mid-Size Mowers
- Groundsmaster Riding Mowers
- Turf Maintenance Equipment
- Debris Management Equipment

\* Some engines used on Toro LCE Products are warranted by the engine manufacturer.

### Instructions for Obtaining Warranty Service

If you think that your Toro Product contains a defect in materials or workmanship, follow this procedure:

1. Contact any Toro Authorized or Master Service Dealer to arrange service at their dealership. To locate a dealer convenient to you, access our website at [www.Toro.com](http://www.Toro.com). U.S. Customers may also call 800-348-2424.
2. Bring the product and your proof of purchase (sales receipt) to the Service Dealer.

If for any reason you are dissatisfied with the Service Dealer's analysis or with the assistance provided, contact us at:

LCB Customer Service Department  
Toro Warranty Company  
8111 Lyndale Avenue South  
Bloomington, MN 55420-1196  
888-577-7466 (U.S. customers)  
877-484-9255 (Canada customers)

### Countries Other than the United States or Canada

Customers who have purchased Toro products exported from the United States or Canada should contact their Toro Distributor (Dealer) to obtain guarantee policies for your country, province, or state. If for any reason you are dissatisfied with your Distributor's service or have difficulty obtaining guarantee information, contact the Toro importer. If all other remedies fail, you may contact us at Toro Warranty Company.

### Owner Responsibilities

You must maintain your Toro Product by following the maintenance procedures described in the operator's manual. Such routine maintenance, whether performed by a dealer or by you, is at your expense.

### Items and Conditions Not Covered

There is no other express warranty except for special emission system coverage on some products. This express warranty does not cover the following:

- Cost of regular maintenance service or parts, such as filters, fuel, lubricants, tune-up parts, blade sharpening, brake and clutch adjustments.
- Any product or part which has been altered or misused or required replacement or repair due to normal wear, accidents, or lack of proper maintenance.
- Repairs necessary due to improper fuel, contaminants in the fuel system, or failure to properly prepare the fuel system prior to any period of non-use over three months.
- Pickup and delivery charges.

All repairs covered by this warranty must be performed by an Authorized Toro Service Dealer using Toro approved replacement parts.

### General Conditions

Repair by an Authorized Toro Service Dealer is your sole remedy under this warranty.

Neither The Toro Company nor Toro Warranty Company is liable for indirect, incidental or consequential damages in connection with the use of the Toro Products covered by this warranty, including any cost or expense of providing substitute equipment or service during reasonable periods of malfunction or non-use pending completion of repairs under this warranty.

Some states do not allow exclusions of incidental or consequential damages, or limitations on how long an implied warranty lasts, so the above exclusions and limitations may not apply to you.

All implied warranties of merchantability (that the product is fit for ordinary use) and fitness for use (that the product is fit for a particular purpose) are limited to the duration of the express warranty.

This warranty gives you specific legal rights, and you may also have other rights which vary from state to state.