



**Count on it.**

**Parts Catalog**

**Z Master® 8000 Series Riding  
Mower**

**with 48in Cutting Unit**

**Model No. 74312—Serial No. 405700000 and Up**



# Ordering Replacement Parts

To order replacement parts, please supply the part number, the quantity, and the description of each part desired.

## Understanding Reference Numbers

Each identified part in an illustration has a reference number. The reference number for a part also appears in the parts list, along with other information about the part.

This catalog uses two special reference number formats, one to indicate parts in a service assembly and another to indicate the quantity of a given part in an illustration.

## Service Assembly Reference Numbers

Parts in service assemblies have reference numbers in the form a:b. The a represents the reference number of the entire service assembly and the b represents a sequential number unique to each part within the service assembly.

For example, a wheel assembly might be identified by reference number 6, the tire by 6:1, the valve by 6:2, and the wheel by 6:3. When you order the assembly identified by reference number 6, you receive all parts identified by reference numbers 6:1, 6:2, and 6:3. However, you may also order any part individually. Reference numbers of this type appear in illustration and in parts lists.

## Reference Numbers Indicating Quantity

In an illustration, if a reference number indicates more than one part, the reference number has the form nX y. The n represents the quantity of the part, the X is the multiplication symbol, and the y represents the reference number.

For example, in an illustration, the reference number 2X 37 means that two of the parts identified by reference number 37 are indicated.

# Contents

Caster Wheel and Frame Assembly .....	4
Frame and Decal Assembly No. 116-7482 .....	6
Speed Control Assembly .....	8
Parking Brake Assembly .....	10
Seat and Consoles Assembly .....	12
Hydraulic Assembly .....	14
Hydraulic Pump Assembly No. 116-7836 .....	16
Idler Assembly No. 103-7349 .....	18
Blower Mounting Assembly .....	20
Blower Assembly No. 116-9649 .....	22
Engine Assembly .....	24
Fuel Tank Assembly .....	26
Electrical System Assembly .....	28
Hopper Switch Actuator Assembly No. 103-8528 .....	30
Hopper Mounting Assembly .....	32
Hopper Assembly No. 130-2872 .....	34
Hopper Screen Assembly No. 109-0717 .....	36
Hopper Frame Assembly No. 109-4086 .....	38
Drive Assembly .....	40
Deck Assembly .....	42
Deck Decal Assembly No. 142-2922 .....	44
Discharge Tube Assembly No. 103-9487 .....	46
Gearbox Assembly No. 103-3387 .....	48
Rear Deck Height Adjustment Assembly No. 109-0323 .....	50
Drive Shaft Assembly No. 103-9485 .....	52
Deck Support Frame Assembly No. 142-2995 .....	54
Deck Support W/Decals Assembly No. 142-2914 .....	56
Lift Assist Spring Assembly No. 116-7851 .....	58
Attachments and Accessories .....	60

# Caster Wheel and Frame Assembly

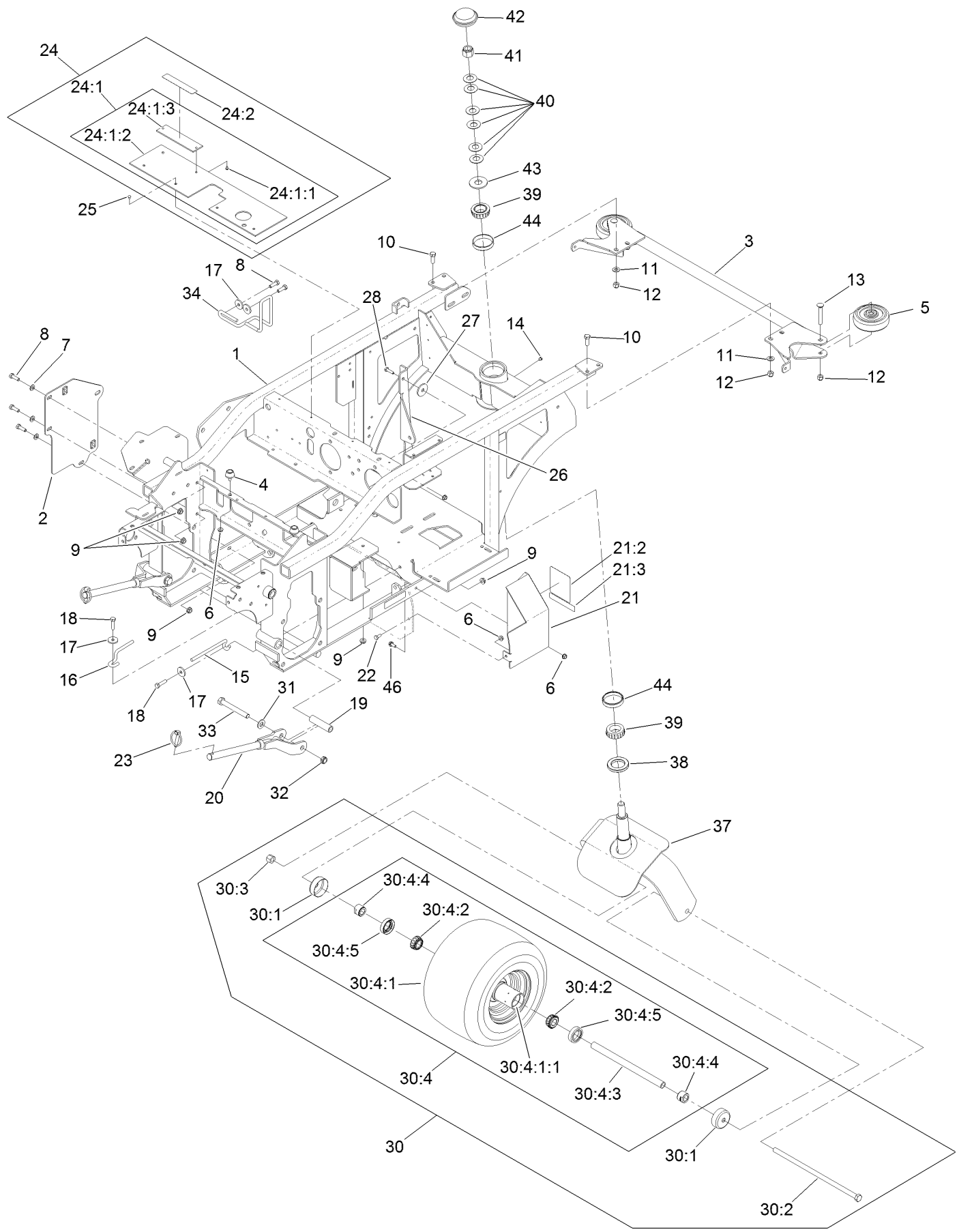

## Caster Wheel and Frame Assembly (continued)

<i>Ref.</i>	<i>Part Number</i>	<i>Qty.</i>	<i>Description</i>	<i>Ref.</i>	<i>Part Number</i>	<i>Qty.</i>	<i>Description</i>
1	116-7482	1	Frame ASM	24:2	98-1977	1	Decal-Warning
2	116-7396-03	1	Plate-Support	25	1-803035	4	Rivet-Pop
3	109-0925-03	1	Bumper-Rear	26	109-5874-03	1	Brace-PTO
4	109-2365	1	Bumper-Rubber	27	1-213069	1	Washer
5	103-5408	2	Roller-Bumper	28	321-6	1	Screw-HH
6	32128-33	5	Nut-HF	30	130-2865	1	Wheel And Axle ASM
7	3256-23	3	Washer-Plain	30:1	103-2768	2	Guard-Seal
8	322-5	5	Screw-HH	30:2	103-7738	1	Screw-HH
9	32128-20	5	Nut-HF	30:3	3296-23	1	Nut-Lock, NI
10	323-6	4	Screw-HH	30:4	130-2864	1	Wheel And Bearing ASM
11	3256-24	4	Washer-Flat	30:4:1		1	Wheel And Tire ASM ●
12	3296-39	6	Nut-Lock, NI	30:4:1:1	1-633584	2	Bearing-Cup
13	3231-31	2	Screw-CARR	30:4:2	1-633585	2	Bearing-Cone, Taper
14	1-811010	1	Plug	30:4:3	126-5362	1	Axle Caster ASM
15	103-8333	1	Guide-Belt	30:4:4	103-3051	1	Spacer-Nut ■
16	103-8349	1	Guide-Belt	30:4:5	103-0063	2	Seal-Caster
17	1-613235	4	Washer	31	3256-26	2	Washer-Flat
18	322-6	2	Screw-HH	32	3296-45	2	Nut-Hex
19	1-633060	2	Spacer-Wheel, Short	33	325-17	2	Screw-HH
20	103-6596-03	2	Rod-Push	34	135-5784	1	Wld-Belt Guide
21	130-2879	1	Drive Shield ASM	37	103-3351-03	1	Fork-Rear Caster
21:2	116-8941	1	Decal-Belt Routing	38	103-9027	1	Seal-Grease
21:3	98-1977	1	Decal-Warning	39	103-9028	2	Bearing-Roller, Cone Taper
22	321-3	1	Screw-HH	40	1-633508	6	Washer-Bellville
23	103-4155	2	Pin-Lynch	41	3296-51	1	Nut-Lock, NI
24	103-9476	1	Lift Shield ASM	42	126-9882	1	Cap-Grease
24:1		1	Shield-Lift ●	43	3256-8	1	Washer-Flat
24:1:1	1-803035	2	Rivet-Pop	44	103-9029	2	Cup-Tapered, Roller Bearing
24:1:2	103-8819	1	Flap-Guard	46	120-4654	1	Screw-HHF
24:1:3	103-9114-03	1	Plate-Decal				

● Not serviced separately

■ Use Pro-Lock, Nut Type (P/N 1-840022, .5ml tube) on threads.

# Frame and Decal Assembly No. 116-7482

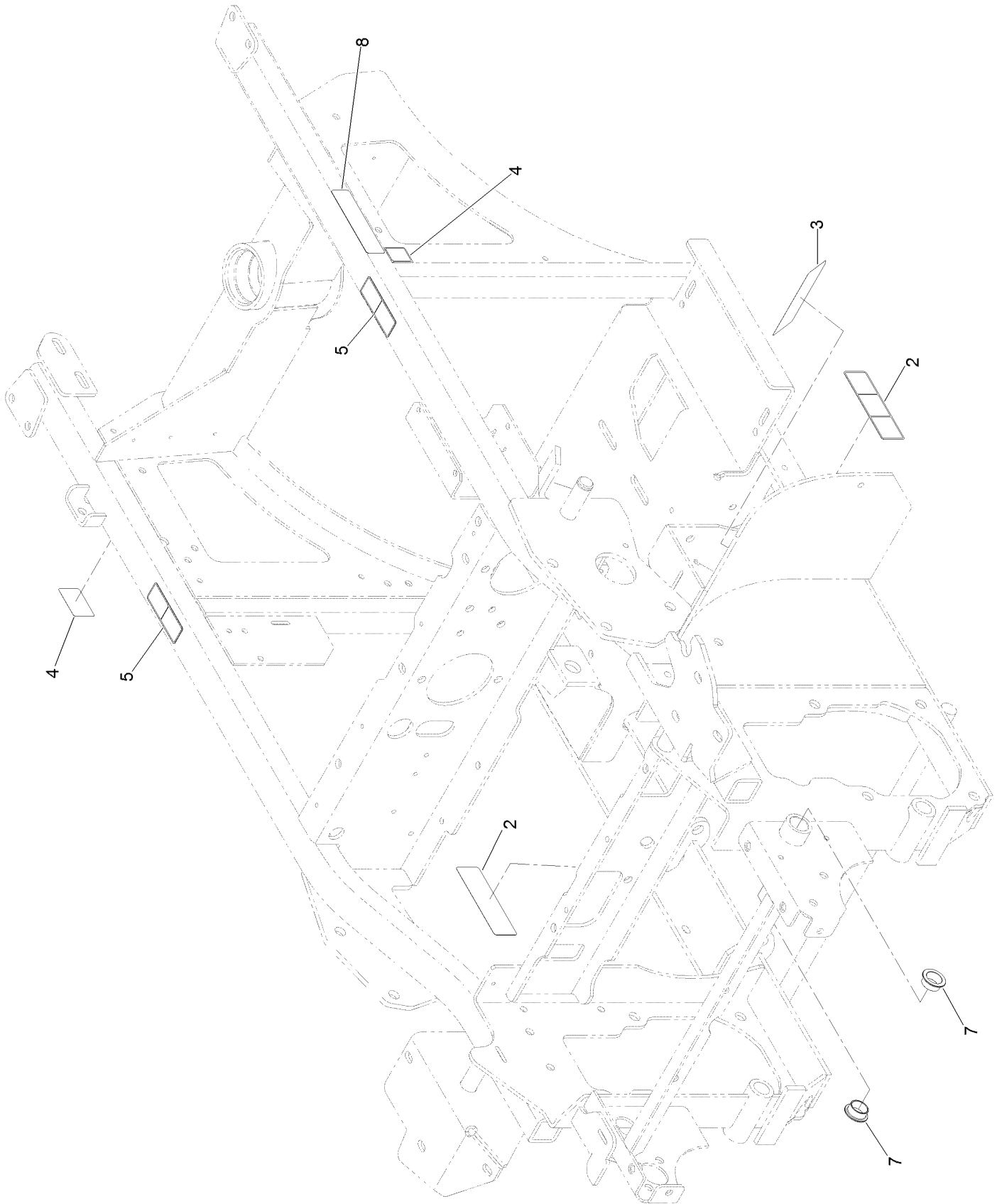

# Frame and Decal Assembly No. 116-7482 (continued)

<i>Ref.</i>	<i>Part Number</i>	<i>Qty.</i>	<i>Description</i>	<i>Ref.</i>	<i>Part Number</i>	<i>Qty.</i>	<i>Description</i>
2	112-9028	2	Decal-Cover, Missing	5	120-0625	2	Decal-Warning
3	126-4207	1	Decal-Adjustment, Clutch	7	108519	2	Bushing-Bronze
4	106-5517	2	Decal-Warning	8	133-8062	1	Decal-Arrestor, Spark





## Speed Control Assembly (continued)

<i>Ref.</i>	<i>Part Number</i>	<i>Qty.</i>	<i>Description</i>	<i>Ref.</i>	<i>Part Number</i>	<i>Qty.</i>	<i>Description</i>
1	116-7856	1	Shaft-Control, Speed	21:4	1-804524	2	Nut
2	3257-5	3	Key-Woodruff	21:5	103-3060	1	Knob-Tracking
3	116-7372	1	Stop-Hub, Center	21:6	103-5945	1	Spacer
4	116-7414	2	Bushing-Plastic	21:7	116-7492	1	Rod-Linkage, Steering
5	116-8475	1	Spring-Torsion, Double	21:8	3219-2	1	Nut-Hex
6	321-11	1	Screw-HH	28	322-6	4	Screw-HH
7	116-8444	1	RH Control Hub ASM	29	104-8300	7	Nut-HF, NI
7:2	103-4398	2	Bearing-Flange, Iglide	30	116-9246	2	Handle ASM
8	116-7380	1	Spring-Torsion, RH	30:2	103-5994	1	Grip-Handle, Steering
9	126-7461	1	RH Steering Handle ASM	32	321-5	4	Screw-HH
9:2	116-7422	2	Bearing-Flange, Iglide	33	32128-33	4	Nut-HF
10	116-7416	1	LH Control Hub ASM	34	103-5009	2	Disc-Friction
10:2	103-4398	2	Bearing-Flange, Iglide	35	116-7846	1	Plate-Friction, Speed Control
11	116-7381	1	Spring-Torsion, LH				
12	126-7463	1	LH Steering Handle ASM	36	116-7845	1	Lever-Speed Control
12:1	116-7422	2	Bearing-Flange, Iglide	37	116-7849	1	Plate-Friction, Speed Control
13	103-4342	2	Hub-Speed Control				
14	108-0989	6	Screw-Set	38	103-5018	3	Washer-Disc, Spring
15	3296-56	1	Nut-Lock, NI	39	3296-19	1	Nut-Hex
16	1-633102	2	Bearing-Flange, Side	40	116-7848	1	Screw-HH
17	323-4	4	Screw-HH	41	116-7859	1	Hub-Control, Speed
18	3290-357	6	Nut-HSF	43	3256-23	1	Washer-Plain
19	3256-3	9	Washer-Flat	44	323-8	1	Screw-HH
20	116-9667	1	RH Pump Linkage ASM	45	103-4397	1	Knob-Ball, Speed Control
20:1	1-323245	2	Spring-Compression	46	3218-3	1	Nut-Jam
20:2	1-543017	1	Balljoint-RH	47	116-7384	1	Console ASM
20:3	1-633152	1	Balljoint-LH	47:2	116-9049	1	Decal-Danger, Driveline
20:4	1-804524	2	Nut	47:3	116-8946	1	Decal-Motor, Wheel
20:5	116-7492	1	Rod-Linkage, Steering	48	103-5993-03	1	Guide-Plenum
20:6	3219-2	2	Nut-Hex	49	322-3	6	Screw-HH
21	116-9668	1	LH Pump Linkage ASM	50	32128-20	3	Nut-HF
21:1	1-323245	2	Spring-Compression	51	103-8494	1	Hook
21:2	1-543017	1	Balljoint-RH	52	322-5	3	Screw-HH
21:3	1-633152	1	Balljoint-LH				

# Parking Brake Assembly

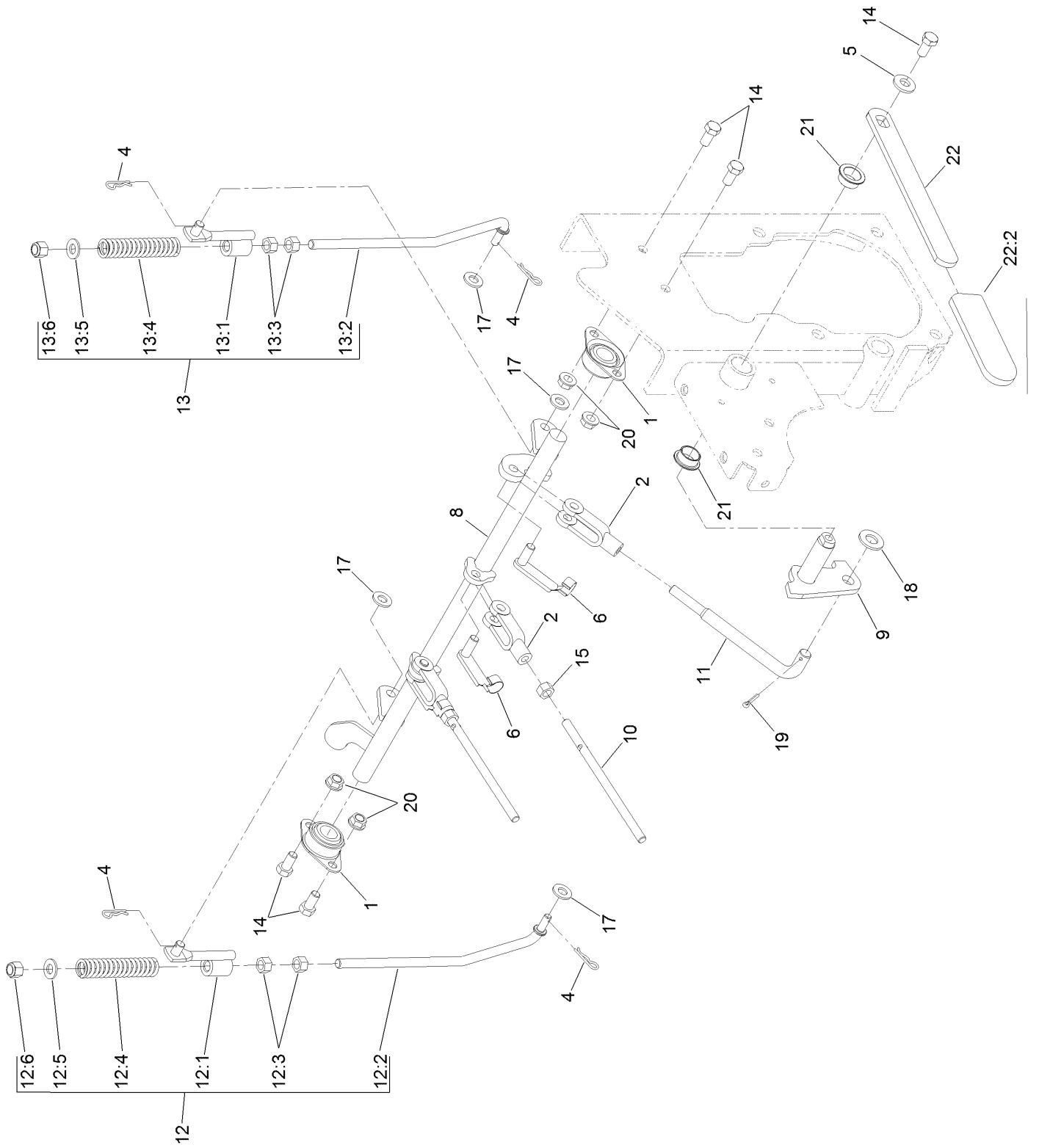

## Parking Brake Assembly (continued)

<i>Ref.</i>	<i>Part Number</i>	<i>Qty.</i>	<i>Description</i>	<i>Ref.</i>	<i>Part Number</i>	<i>Qty.</i>	<i>Description</i>
1	1-633102	2	Bearing-Flange, Side	13	116-9749	1	LH Brake Linkage ASM
2	1-633131	3	Yoke-Linkage, Brake	13:1	116-8467	1	Brake Linkage ASM
4	1-806003	4	Pin-Cotter	13:2	116-8464	1	Link-Brake, LH
5	98-5975	1	Washer-Belleville	13:3	3219-3	2	Nut-Hex
6	103-2399	3	Pin-Spring, Clevis	13:4	116-8470	1	Spring-Compression
8	116-7483-03	1	Shaft-Brake	13:5	3256-24	1	Washer-Flat
9	116-7486	1	Pivot-Brake	13:6	3296-6	1	Nut-Lock
10	116-7838	2	Rod-Linkage, Brake	14	323-4	5	Screw-HH
11	116-8474	1	Rod-Linkage, Brake	15	3219-3	2	Nut-Hex
12	116-9748	1	RH Brake Linkage ASM	17	3256-24	4	Washer-Flat
12:1	116-8467	1	Brake Linkage ASM	18	3256-26	1	Washer-Flat
12:2	116-8465	1	Link-Brake, RH	19	3272-10	1	Pin-Cotter
12:3	3219-3	2	Nut-Hex	20	3290-357	4	Nut-HSF
12:4	116-8470	1	Spring-Compression	21	108519	2	Bushing-Bronze
12:5	3256-24	1	Washer-Flat	22	103-9469	1	Park Brake Handle ASM
12:6	3296-6	1	Nut-Lock	22:2	1-633268	1	Grip-Lever

# Seat and Consoles Assembly

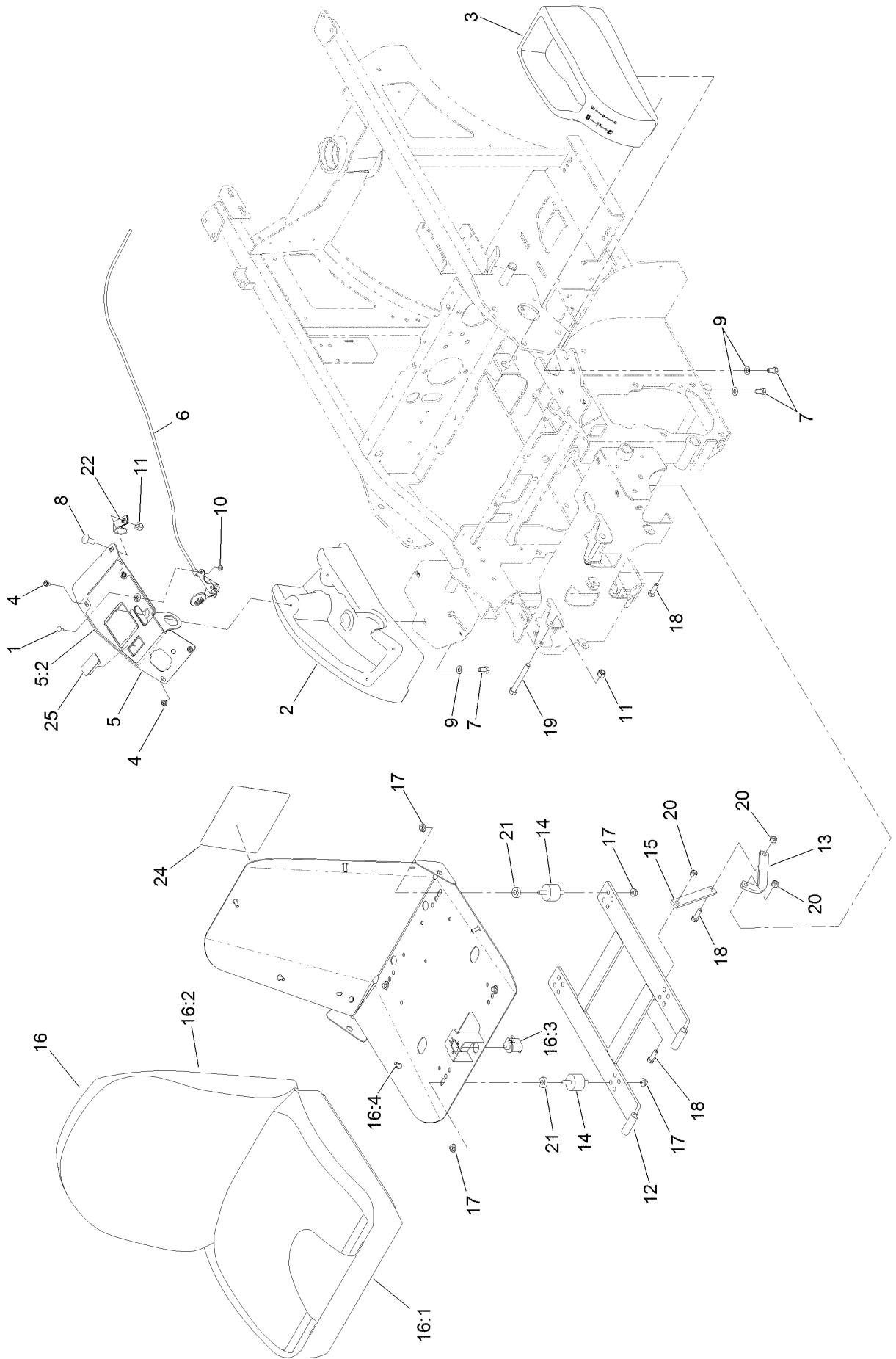

## Seat and Consoles Assembly (continued)

<i>Ref.</i>	<i>Part Number</i>	<i>Qty.</i>	<i>Description</i>	<i>Ref.</i>	<i>Part Number</i>	<i>Qty.</i>	<i>Description</i>
1	1-807513	2	Bolt-CARR	15	103-8563	1	Link-Seat
2	130-2857	1	Console-RH	16	130-2852	1	Seat ASM
3	126-4343	1	Console-LH	16:1	121-4751	1	Cushion-Seat, Bottom
4	109-2661	4	Screw-PPH	16:2	121-4752	1	Cushion-Seat, Back
5	130-2895	1	Control Panel ASM	16:3	82-2190	1	Switch-Bail
5:2	130-2881	1	Decal-Control	16:4	103-8383	5	Bolt-Seat
6	109-4641	1	Cable-Throttle	17	32128-20	8	Nut-HF
7	322-2	6	Screw-HH	18	322-5	3	Screw-HH
8	3231-27	1	Screw-CARR	19	323-14	2	Screw-HH
9	3256-23	6	Washer-Plain	20	3296-29	3	Nut-Lock, NI
10	3296-2	2	Nut-Lock, NI	21	5-0652	4	Spacer
11	3296-39	3	Nut-Lock, NI	22	1-643312	1	Clip-Loom
12	103-4362-03	1	Frame-Seat	24	116-9044	1	Decal-Service Aid
13	116-9554	1	Link-Seat Stop	25	99-7420	1	Plug-Hole
14	103-5496	4	Mount-Vibration, Rubber				

# Hydraulic Assembly

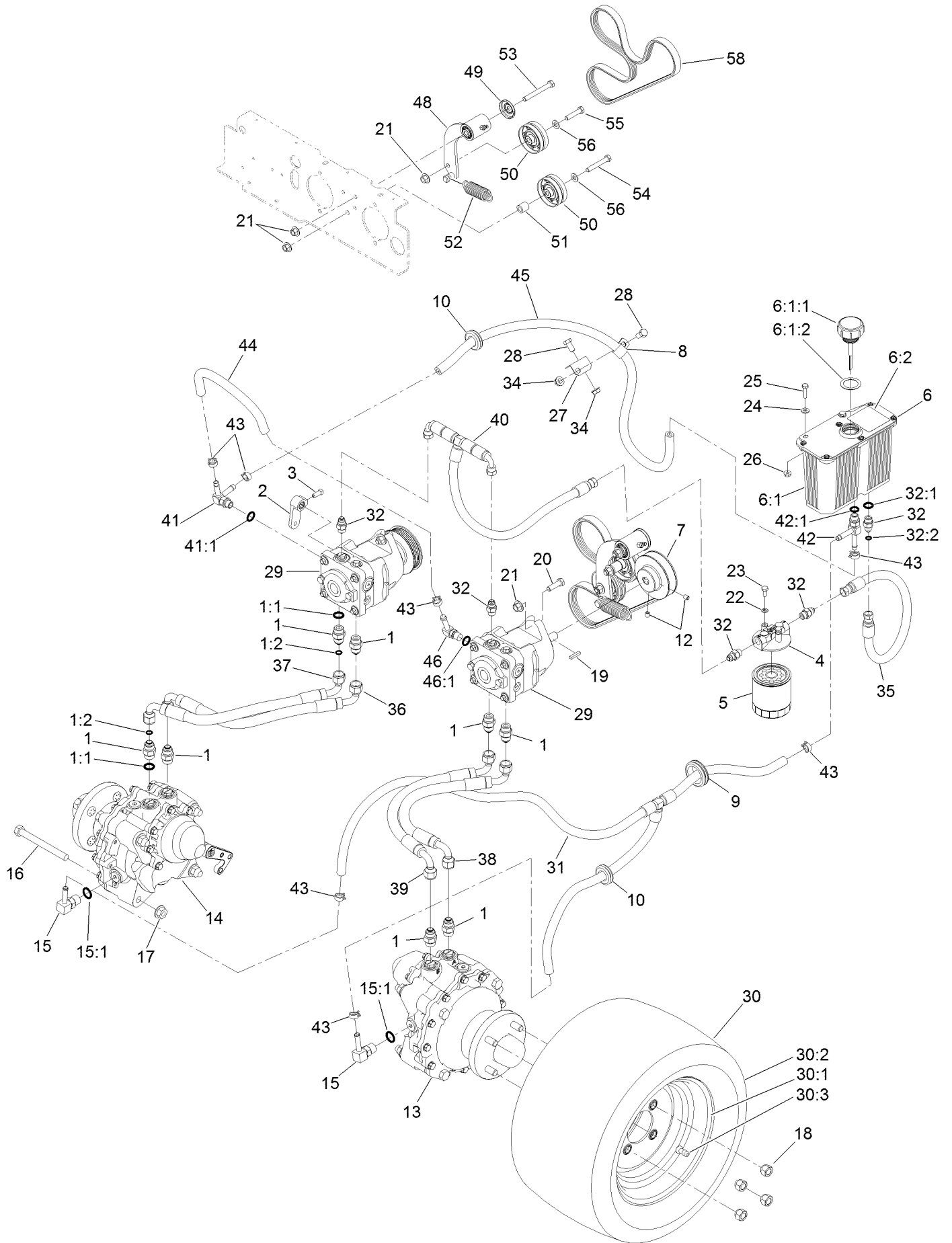

## Hydraulic Assembly (continued)

<i>Ref.</i>	<i>Part Number</i>	<i>Qty.</i>	<i>Description</i>	<i>Ref.</i>	<i>Part Number</i>	<i>Qty.</i>	<i>Description</i>
1	1-603990	8	Fitting-Straight	30	130-2869	2	Wheel And Tire ASM
1:1	1-603920	1	O-Ring	30:1	130-2868	1	Wheel
1:2	1-603992	1	O-Ring	30:2	105-1945	1	Tire
2	1-632208	2	Arm-Control, Pump	30:3	232-27	1	Stem-Valve
3	120-6474	2	Screw-Set, SQH	31	116-7831	1	Hydraulic Hose ASM
4	104-7836	1	Head-Filter	32	103-2156	5	Fitting-Straight
5	114-3494	1	Element-Filter, 25 Micron	32:1	1-603921	1	O-Ring
6	116-9274	1	Reservoir ASM	32:2	103-1020	1	O-Ring
6:1		1	Reservoir-HYD ●	34	3290-357	2	Nut-HSF
6:1:1	116-9273	1	Reservoir Cap ASM	35	126-4400	1	Hydraulic Hose ASM
6:1:2	103-1949	1	Gasket-Cap	36	116-7827	1	Hydraulic Hose ASM
6:2	115-4212	1	Decal-Warning	37	116-7828	1	Hydraulic Hose ASM
7	103-4246	2	Sheave	38	116-7829	1	Hydraulic Hose ASM
8	1-633396	1	Clip-Loom	39	116-7830	1	Hydraulic Hose ASM
9	103-7706	1	Grommet	40	109-1264	1	Hydraulic Hose ASM
10	1-543286	2	Grommet	41	103-5469	1	Adapter-Tee
12	1-803310	4	Screw-Set	41:1	237-42	1	Adapter
13	116-7401	1	Motor-HYD, LH	42	103-1828	1	Adapter-Run, Tee
14	116-7402	1	Motor-HYD, RH	42:1	237-42	1	O-Ring
15	354-134	2	Fitting-90	43	103-1988	7	Clamp-Hose
15:1	237-79	1	O-Ring	44	103-5452	1	Hose-HYD
16	325-19	8	Screw-HH	45	103-5477	1	Hose-HYD
17	32128-49	8	Nut-HHF	46	100-4887	1	Fitting-Elbow, 90
18	242-50	8	Nut-Lug	46:1	237-42	1	O-Ring
19	1-807272	2	Key	48	103-7349	1	Short Idler ASM
20	323-7	4	Screw-HH	49	103-2916	1	Guard-Top
21	32128-43	7	Nut-Flange	50	116-6361	2	Pulley
22	1-805004	2	Washer-Lock	51	106-5574	1	Spacer-Mounting, Steering
23	321-3	2	Screw-HH	52	1-653331	1	Spring-Idler
24	3256-22	2	Washer-Flat	53	323-20	1	Screw-HH
25	321-6	2	Screw-HH	54	323-12	1	Screw-HH
26	32128-33	2	Nut-HF	55	323-9	1	Screw-HH
27	103-8631	1	Bracket-Clamp	56	3256-24	2	Washer-Flat
28	323-4	2	Screw-HH	58	130-2871	1	Belt-V
29	116-7836	2	12Cc Hydro Pump ASM				

● Not serviced separately

# Hydraulic Pump Assembly No. 116-7836

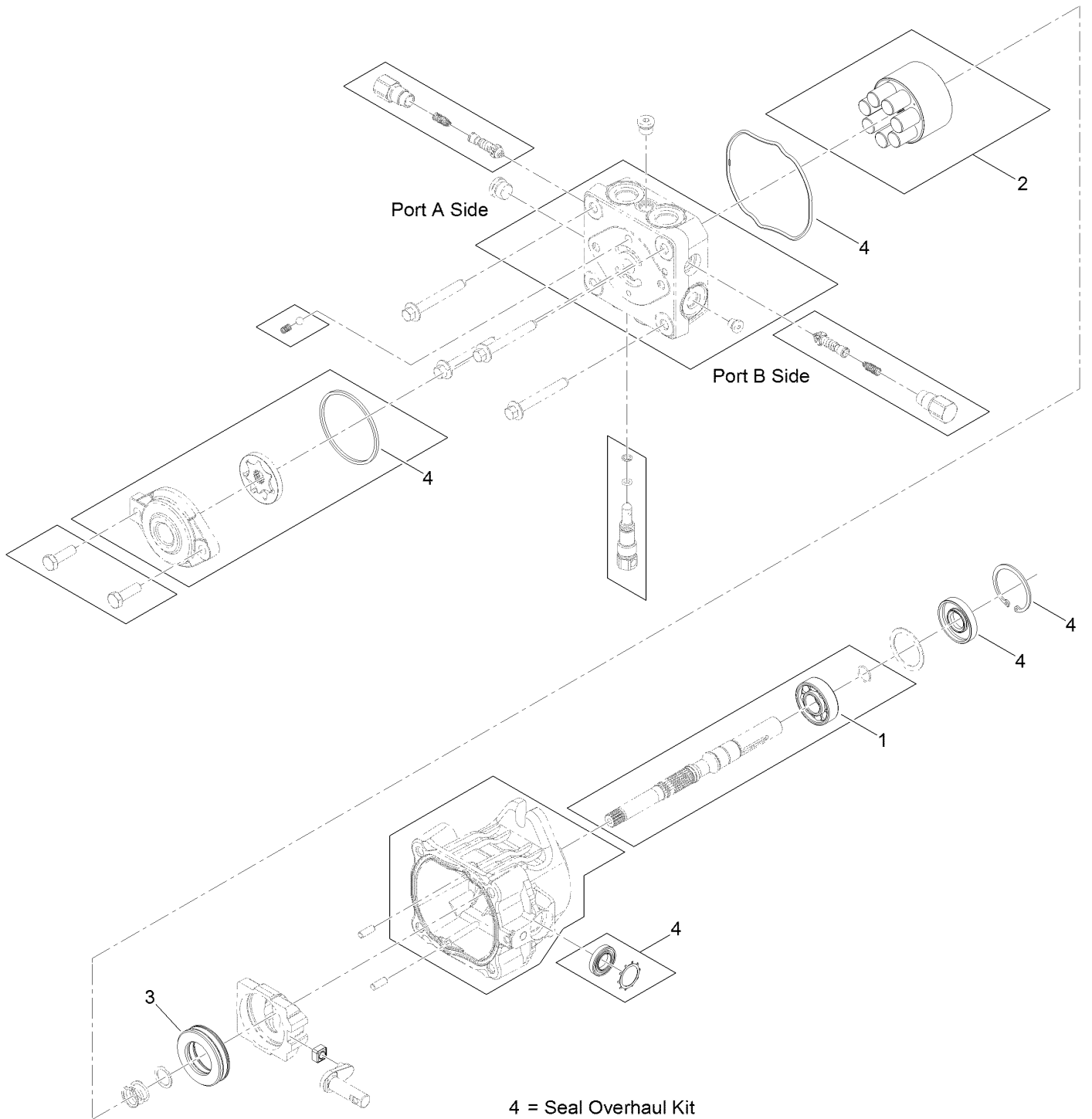



# Hydraulic Pump Assembly No. 116-7836 (continued)

<i>Ref.</i>	<i>Part Number</i>	<i>Qty.</i>	<i>Description</i>	<i>Ref.</i>	<i>Part Number</i>	<i>Qty.</i>	<i>Description</i>
1	104-5311	1	Bearing-Ball	3	121-3235	1	Bearing-Thrust, Plastic Cage
2	103-7443	1	Cylinder Block Kit	4	105-6184	1	Seal Overhaul Kit

# Idler Assembly No. 103-7349

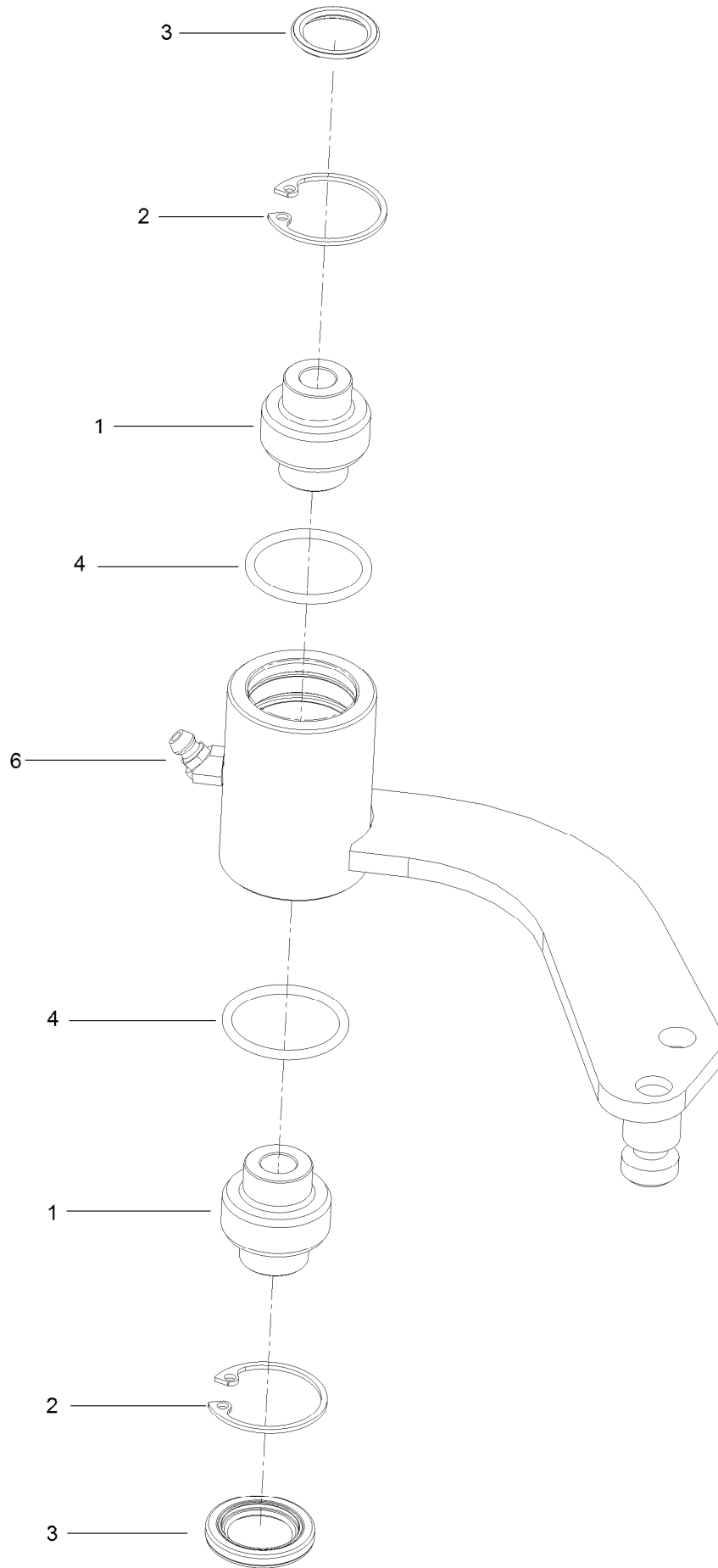

## Idler Assembly No. 103-7349 (continued)

<i>Ref.</i>	<i>Part Number</i>	<i>Qty.</i>	<i>Description</i>
1	103-3504	2	Bearing-Spherical
2	32120-10	2	Ring-Snap
3	103-3506	2	Seal-Lip, Single

<i>Ref.</i>	<i>Part Number</i>	<i>Qty.</i>	<i>Description</i>
4	106-7159	2	O-Ring
6	302-11	1	Fitting-Lube, 45 DEG

# Blower Mounting Assembly

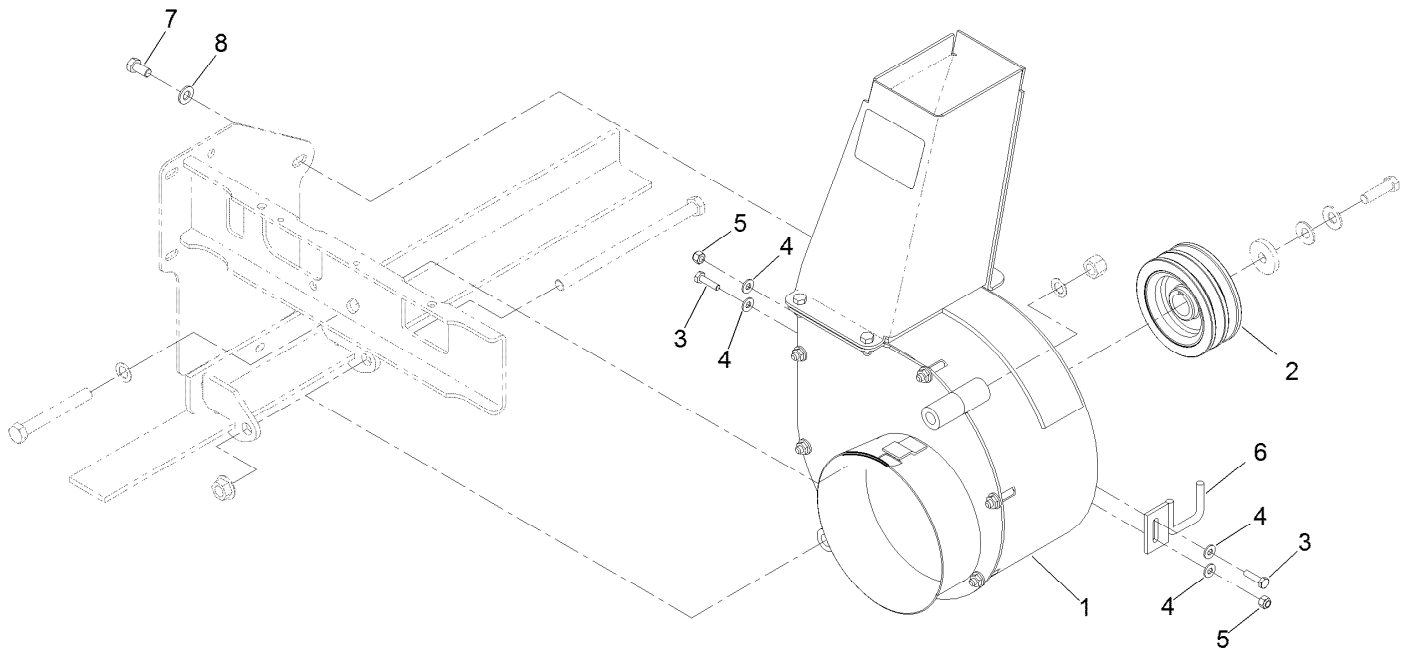

## Blower Mounting Assembly (continued)

<i>Ref.</i>	<i>Part Number</i>	<i>Qty.</i>	<i>Description</i>	<i>Ref.</i>	<i>Part Number</i>	<i>Qty.</i>	<i>Description</i>
1	116-9649	1	Blower ASM	5	3296-42	2	Nut-Lock, NI
2	103-6733	1	Sheave-Blower	6	103-9167-03	1	Guide
3	321-6	2	Screw-HH	7	323-4	1	Screw-HH
4	3256-22	4	Washer-Flat	8	3256-24	1	Washer-Flat

# Blower Assembly No. 116-9649

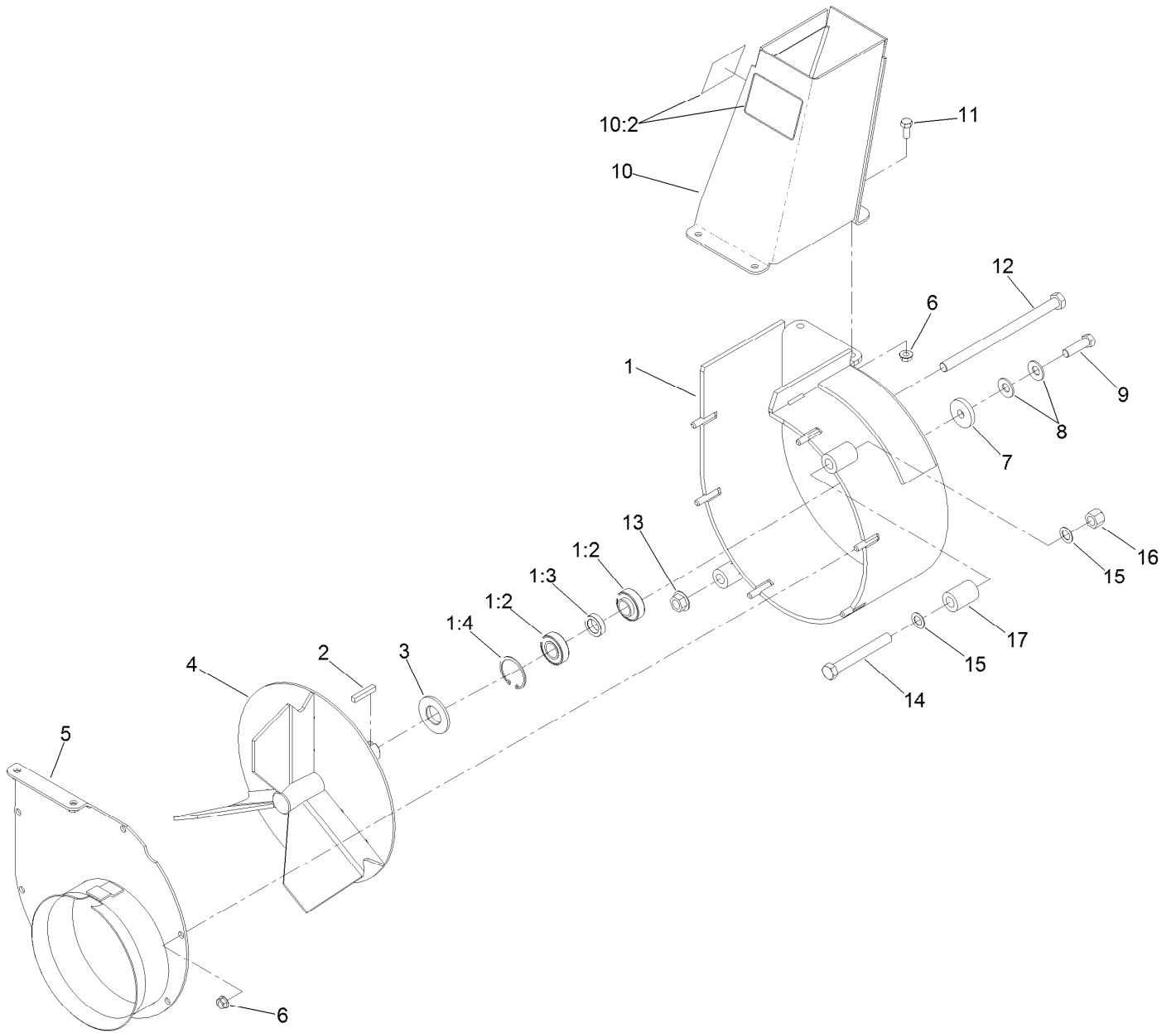

## Blower Assembly No. 116-9649 (continued)

<i>Ref.</i>	<i>Part Number</i>	<i>Qty.</i>	<i>Description</i>	<i>Ref.</i>	<i>Part Number</i>	<i>Qty.</i>	<i>Description</i>
1	116-9648	1	Housing ASM	9	3212-6	1	Screw-HH
1:2	103-3540	2	Bearing-Ball	10	103-9474	1	Discharge Chute ASM
1:3	103-4921	1	Spacer-Bearing	10:2	116-8943	2	Decal-Danger, Impeller
1:4	32120-8	2	Ring-Snap	11	322-3	4	Screw-HH
2	67-7490	1	Key-Square	12	325-42	1	Screw-HH
3	103-3894	1	Spacer-Blower	13	32128-23	1	Nut-HF
4	103-5194	1	Impeller-3 Blade	14	325-17	1	Screw-HH
5	103-3370-03	1	Cover-Blower	15	18-9810	2	Washer-Thrust
6	32128-20	10	Nut-HF	16	3296-23	1	Nut-Lock, NI
7	1-543610	1	Washer-Clutch	17	103-6999	1	Spacer-Mount
8	1-603610	2	Washer-Spring				

# Engine Assembly

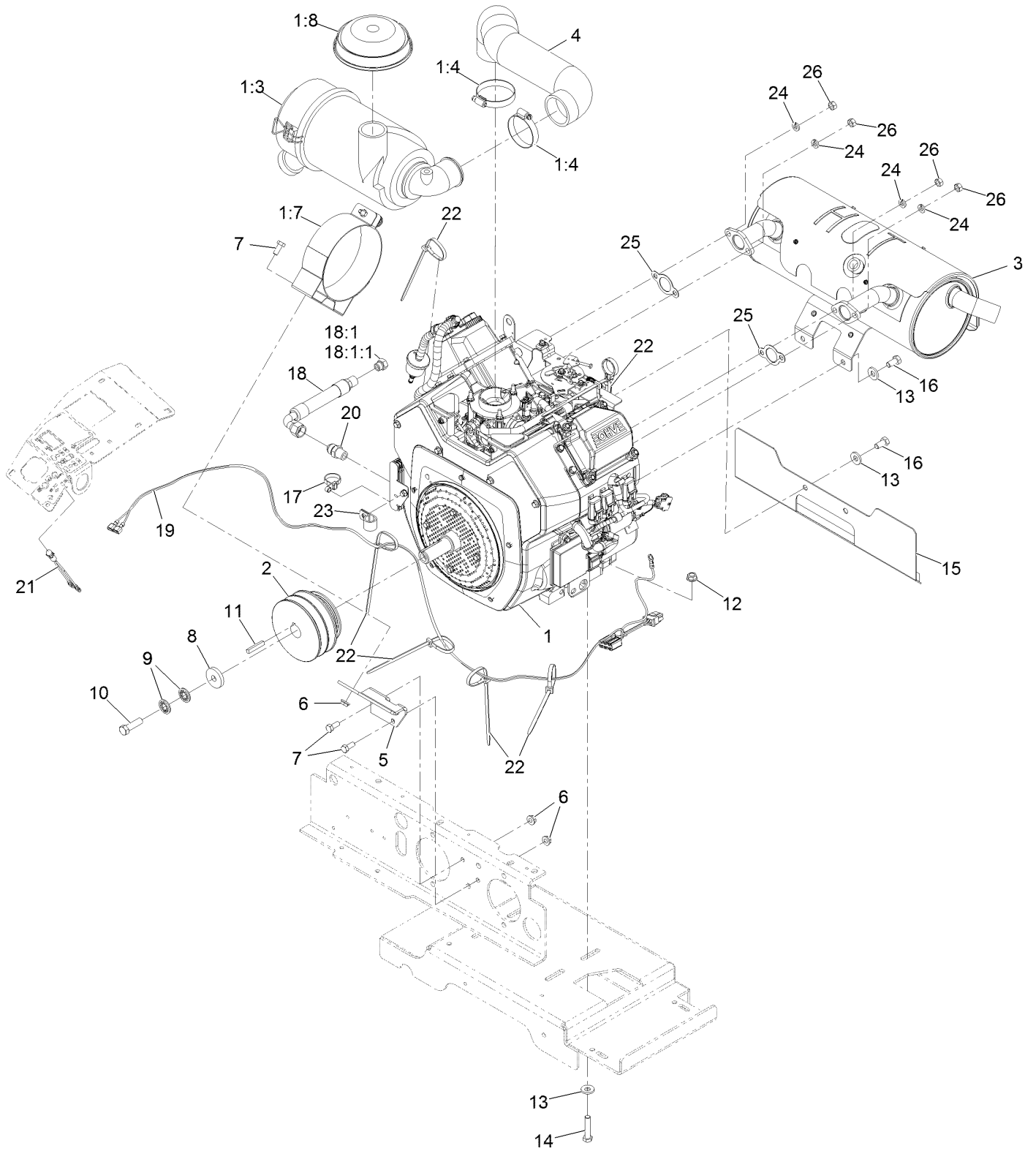



## Engine Assembly (continued)

<i>Ref.</i>	<i>Part Number</i>	<i>Qty.</i>	<i>Description</i>	<i>Ref.</i>	<i>Part Number</i>	<i>Qty.</i>	<i>Description</i>
1		1	Engine-Kohler, Ech730-3064 ●■	12	3290-357	4	Nut-Whizlock 3/8-16
1:3	103-8569	1	Air Cleaner Canister ASM	13	98-5975	8	Washer-Spring Disc 3/8
1:4	2412-42	2	Clamp-Hose	14	323-9	4	Screw-HH 3/8-16 X 1 3/4
1:7	103-1058	1	Bracket-Filter, Air	15	109-0181-03	1	Shield-Exhaust
1:8	100-2436	1	Asm-Hood Air Intake W/Clamp	16	323-4	4	Screw-HH 3/8-16 X 3/4
2	103-6731	1	Sheave-Engine	17	109-7896	1	Tie-Cable
3	116-3961	1	Muffler	18	116-5338	1	Oil Drain Hose ASM
4	116-4016	1	Hose-Air Intake	18:1	353-508	1	Plug-W/O-Ring
5	103-3695-03	1	Bracket-Filter, Air	18:1:1	237-42	1	O-Ring
6	32128-20	4	Nut-Whizlock 5/16-18	19	116-4543	1	Harness-Light Indicator (EFI)
7	322-3	4	Screw-HH 5/16-18 X 3/4	20	116-1455	1	Fitting-Straight ▲
8	1-543610	1	Washer	21	1-643267	1	Indicator-Red LED
9	1-603610	2	Washer-Spring Disc 7/16	22	1-303335	6	Tie-Cable 7 15/16 (Large)
10	3212-6	1	Screw-HH 7/16-20 X 1 1/2 ◆	23	1-633396	1	Clip-Loom 5/8
11	67-7490	1	Key-Machine 1/4 X 1/4 X 1 1/2	24	1-805005	4	Washer-Lock 5/16 Heavy
				25	1-653291	2	Gasket-Exhaust
				26	33014-00	4	Nut-Hex M8-1.25

● Not serviced separately

▲ Use a Teflon Pipe Sealant or equivalent on threads.

◆ Use Pro-Lock, Nut Type (P/N 1-840022, .5ml tube) on threads.

■ Obtain parts from [www.kohlerplus.com](http://www.kohlerplus.com)

# Fuel Tank Assembly

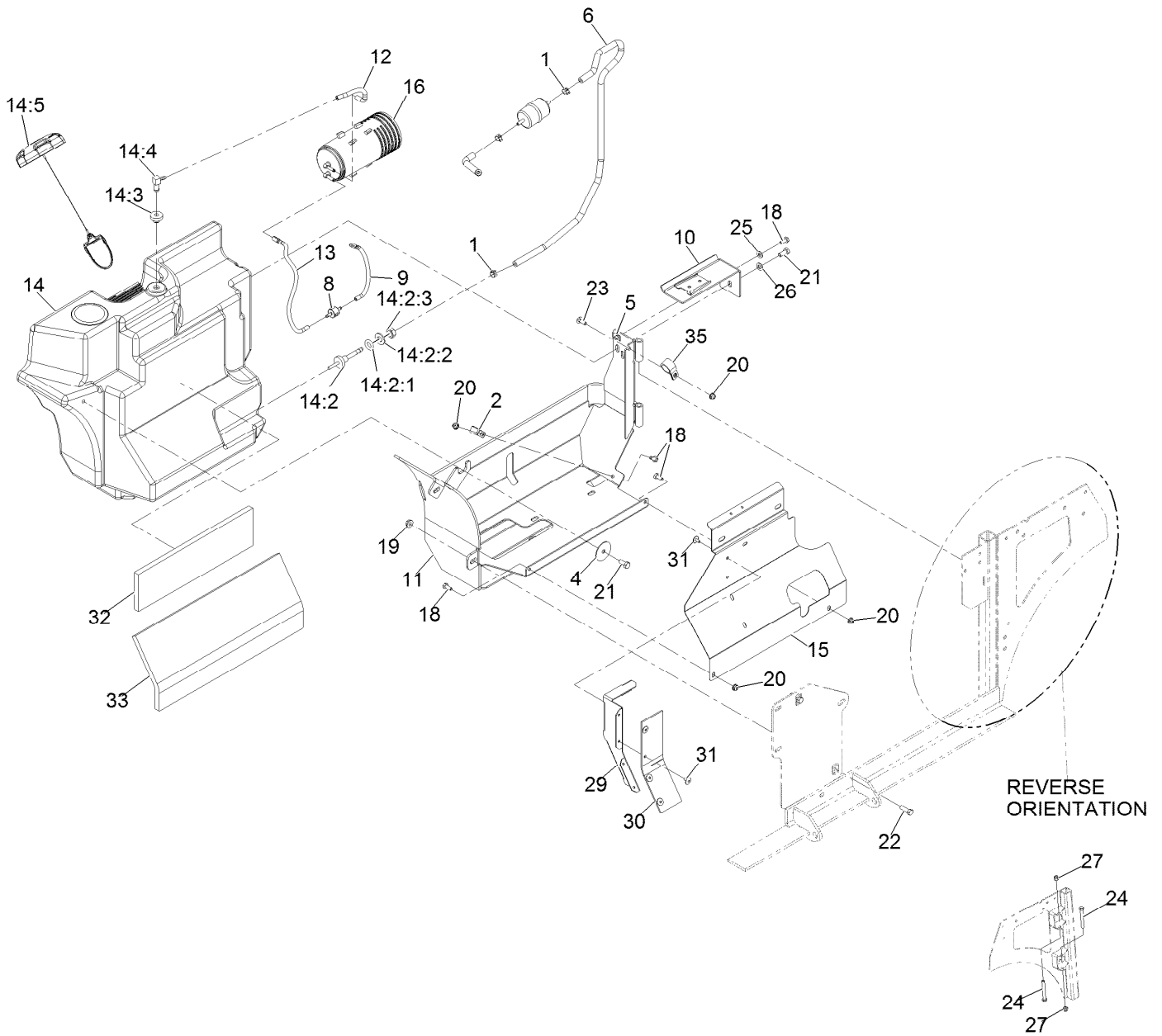

## Fuel Tank Assembly (continued)

<i>Ref.</i>	<i>Part Number</i>	<i>Qty.</i>	<i>Description</i>	<i>Ref.</i>	<i>Part Number</i>	<i>Qty.</i>	<i>Description</i>
1	2412-98	2	Clamp-Hose	15	116-7928-03	1	Panel-Tank Shield
2	1-513762	1	Clip-Loom	16	117-1221	1	Canister-Carbon, 800Cc
4	1-653036	1	Washer	18	321-3	4	Screw-HH
5	107069	1	Clip	19	32128-20	2	Nut-HF
6	116-5366	1	Fuel Line ASM	20	104-7201	4	Nut-HF, NI
8	133-8499	1	Valve-Check, Vacuum	21	322-3	2	Screw-HH ●
9	116-2619	1	Hose-Vent, Formed	22	322-5	2	Screw-HH ■
10	116-2847-03	1	Canister Bracket ASM	23	3229-1	1	Screw-CARR
11	116-2848-03	1	Tank Frame ASM	24	323-14	2	Screw-HH
12	116-2966	1	Hose-Vent, Formed	25	3256-22	1	Washer-Flat
13	116-2967	1	Hose-Vent, Formed	26	3256-23	1	Washer-Plain
14	116-8365	1	Fuel Tank ASM	27	3296-39	2	Nut-Lock, NI
14:2	103-6057	1	Fitting-Fuel, Bulkhead ●	29	103-7095-03	1	Deflector-Air
14:2:1	103-2784	1	O-Ring	30	103-9658	1	Flap-Rubber
14:2:2	3256-26	1	Washer-Flat	31	1-803035	9	Rivet-Pop
14:2:3	3220-5	1	Nut-Jam	32	103-7825	1	Insulation-Foam Pad, Front
14:3	46-6560	1	Bushing	33	103-7824	1	Insulation-Foam Pad, Rear
14:4	100-1596	1	Fitting-90 DEG	35	110-0824	1	R-Clamp
14:5	137-4119	1	Cap-Fuel, Ratcheting				

● Use Pro-Lock, Nut Type (P/N 1-840022, .5ml tube) on threads.

■ Use Pro-Lock retaining type, Part no. 1-840023 (.5cc tube) on threads.

# Electrical System Assembly

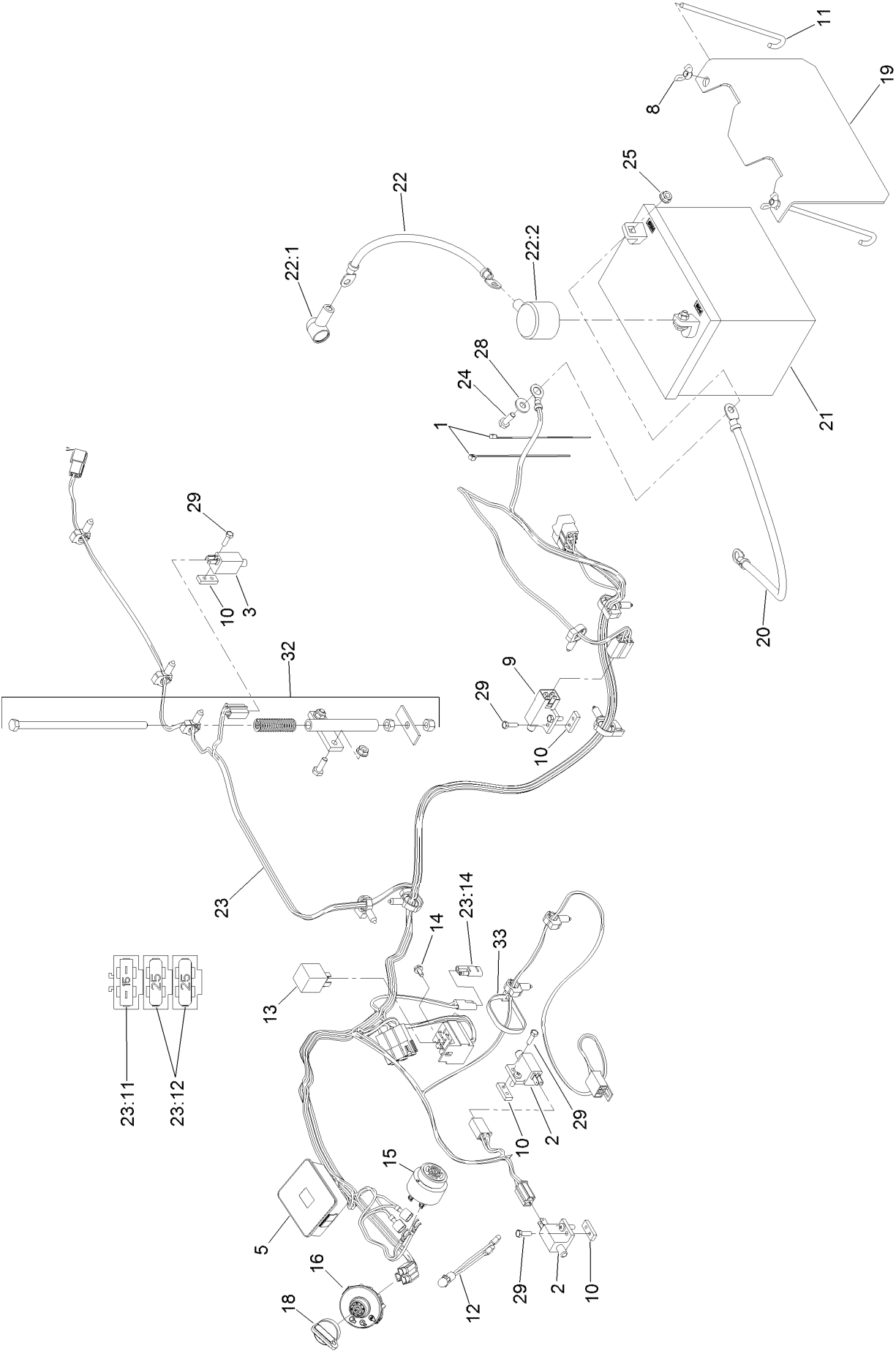

## Electrical System Assembly (continued)

<i>Ref.</i>	<i>Part Number</i>	<i>Qty.</i>	<i>Description</i>	<i>Ref.</i>	<i>Part Number</i>	<i>Qty.</i>	<i>Description</i>
1	1-303287	2	Tie-Cable	21		1	Battery ●■
2	1-513051	2	Switch-Open, Normally	22	116-4730	1	Cable-Battery, Positive
3	1-513152	1	Switch-Closed, Normally	22:1	1-543393	1	Insulator-Solenoid
5	116-8812	1	Hour Meter ASM	22:2	109-2407	1	Insulator-Battery
8	1-543792	2	Wingnut	23	116-9114	1	Harness-Wiring ▲
9	1-633111	1	Switch	23:11	109355	1	Fuse-Blade, 15 Amp
10	1-633181	4	Plate-Tapped	23:12	109102	2	Fuse-Blade, 25 Amp
11	1-633651	2	Bolt-Holddown	23:14	116-0053	1	Cap-Plug
12	1-643267	1	Indicator-LED, Red	24	321-4	2	Screw-HH
13	1-643275	1	Relay	25	32128-33	2	Nut-HF
14	104-2065	1	Screw-HWH	28	3256-2	2	Washer-Flat
15	103-0205	1	Alarm-Tone, Dual	29	3290-134	8	Screw
16	137-4100	1	Switch-Ignition	32	103-8528	1	Hopper Switch Actuator ASM
18	63-8360	1	Key-Ignition	33	1-303335	4	Tie-Plastic
19	103-4161-03	1	Hold Down-Battery				
20	103-8355	1	Cable-Battery, Negative				

● Obtain locally.

■ Not serviced separately

▲ Use dielectric grease on all unsealed connectors and terminals only. Do not apply in sealed connectors.

# Hopper Switch Actuator Assembly No. 103-8528

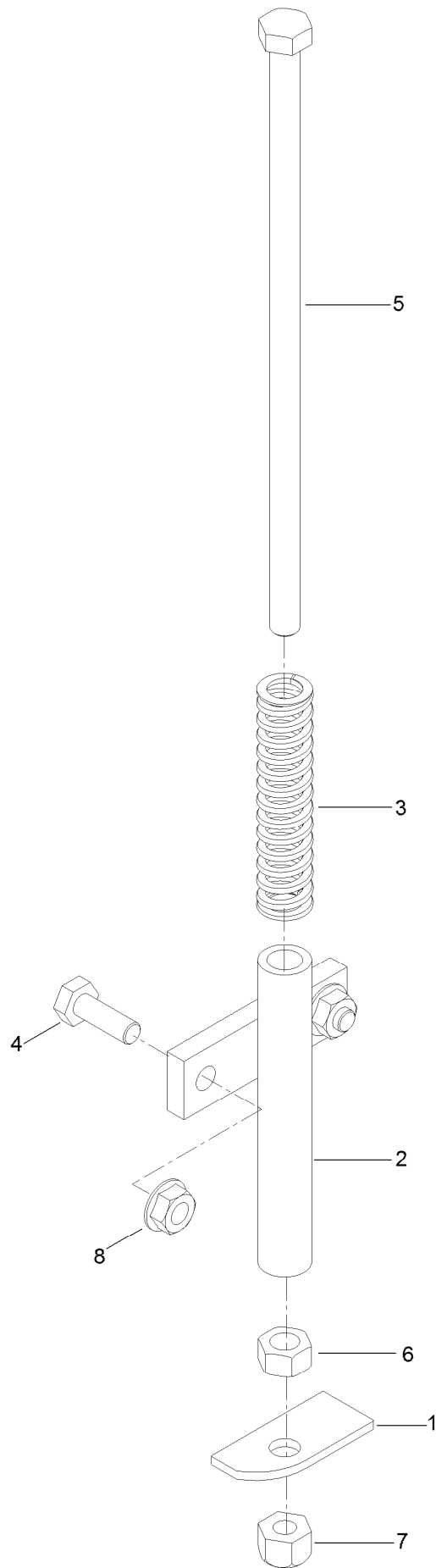

# Hopper Switch Actuator Assembly No. 103-8528 (continued)

<i>Ref.</i>	<i>Part Number</i>	<i>Qty.</i>	<i>Description</i>	<i>Ref.</i>	<i>Part Number</i>	<i>Qty.</i>	<i>Description</i>
1	126-7505	1	Plate-Switch	5	322-50	1	Screw-HH
2	1-522424-03	1	Mount-Spring, Seat	6	3217-6	1	Nut-Hex
3	1-523415	1	Spring-Switch, Seat	7	3296-29	1	Nut-Lock, NI
4	321-4	2	Screw-HH	8	32128-33	2	Nut-HF

# Hopper Mounting Assembly

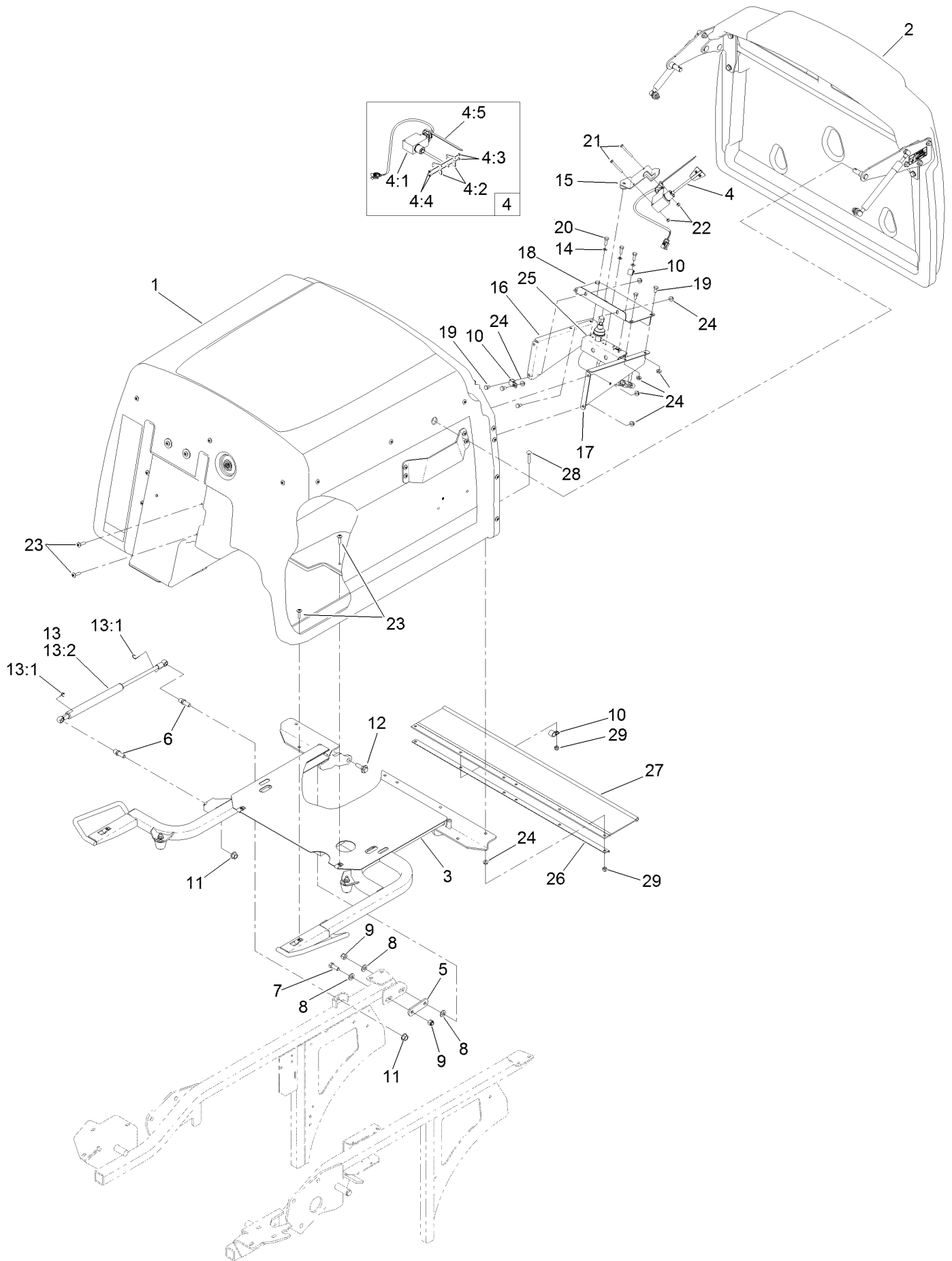



## Hopper Mounting Assembly (continued)

<i>Ref.</i>	<i>Part Number</i>	<i>Qty.</i>	<i>Description</i>	<i>Ref.</i>	<i>Part Number</i>	<i>Qty.</i>	<i>Description</i>
1	130-2872	1	Hopper ASM	13:1	103-8325	2	Clip-Retainer
2	130-2875	1	Hopper Door ASM	13:2	103-5425	1	Shock-Compression, Gas
3	109-4086	1	Hopper Frame ASM	14	1-303435	3	Washer-Spring
4	116-9404	1	Fill Sensor ASM	15	109-3648	1	Mount-Switch
4:1	109-3854	1	Fill Sensor Wire Kit	16	103-6067-03	1	Bracket-Drive Motor, LH
4:2	103-8789	2	Flag-Sensor, Fill	17	103-6068-03	1	Bracket-Drive Motor, RH
4:3	3296-9	2	Nut-Hex	18	103-7085-03	1	Plate-Switch
4:4	9107622	2	Screw-Pan	19	321-2	7	Screw-HH
4:5	1-303335	1	Tie-Plastic	20	329-4	3	Screw-HH
5	1-633068	2	Arm-Lift, Deck	21	3250-48	2	Screw-PPH
6	103-5426	2	Stud-Ball	22	3296-2	2	Nut-Lock, NI
7	323-6	2	Screw-HH	23	32105-32	8	Screw-TTH
8	3256-24	6	Washer-Flat	24	32128-33	17	Nut-HF
9	3296-39	4	Nut-Lock, NI	25	103-9121	1	Motor Wiring ASM
10	1-513762	3	Clip-Loom	26	103-6022-03	1	Channel-Frame, Hopper
11	33005-00	2	Nut-HF	27	103-6025	1	Deflector-Grass
12	614672	2	Screw-Shoulder, HWH	28	3229-4	6	Screw-CARR
13	109-0716	1	Damper Kit	29	3296-42	6	Nut-Lock, NI

# Hopper Assembly No. 130-2872

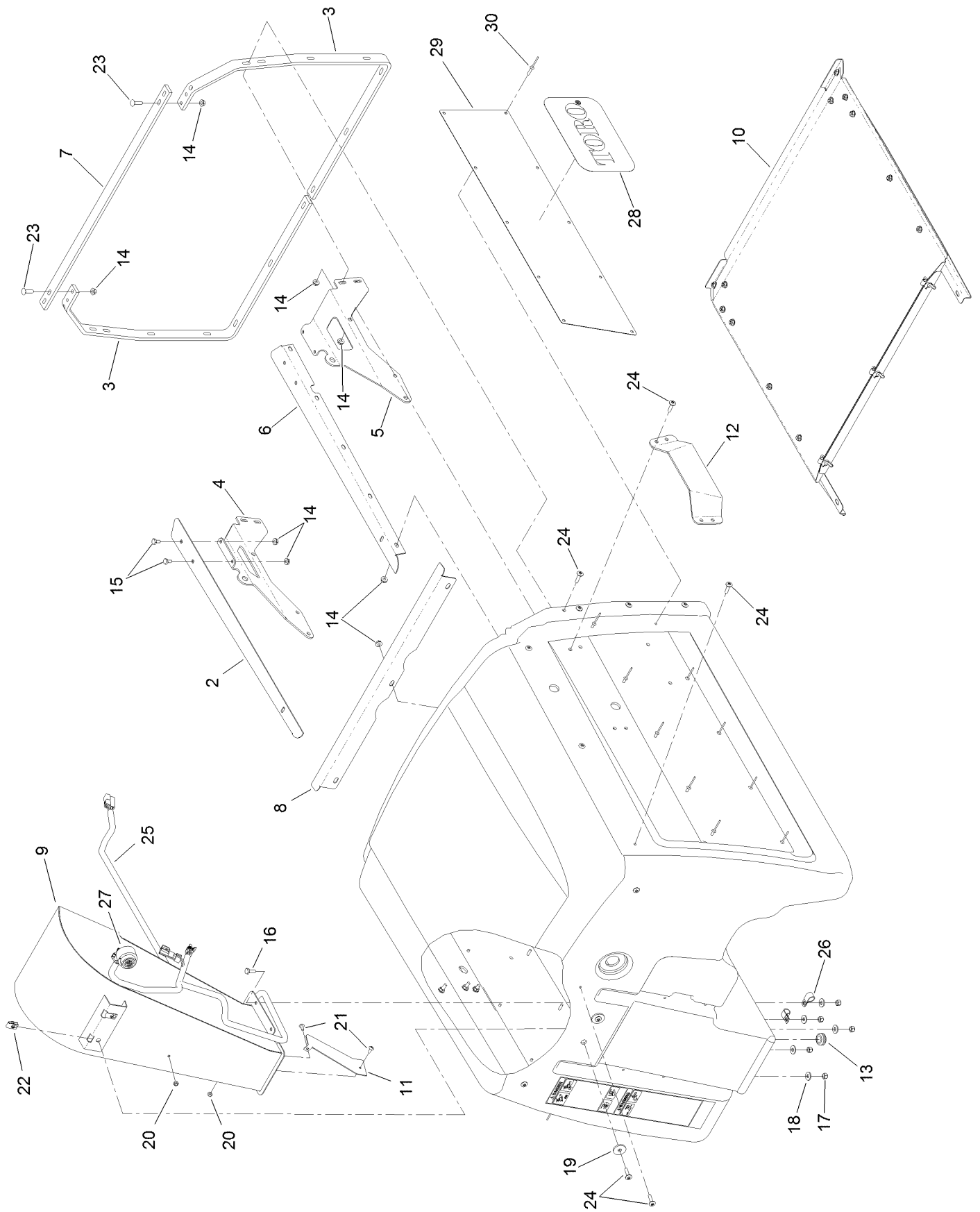

## Hopper Assembly No. 130-2872 (continued)

<i>Ref.</i>	<i>Part Number</i>	<i>Qty.</i>	<i>Description</i>	<i>Ref.</i>	<i>Part Number</i>	<i>Qty.</i>	<i>Description</i>
2	103-5736-03	1	Angle-Screen Track, RH	17	3296-42	5	Nut-Lock, NI
3	103-5045-03	2	Reinforcement-Hopper	18	3256-2	5	Washer-Flat
4	103-5751-03	1	Brace-Door Pivot, RH	19	1-613235	2	Washer
5	103-5749-03	1	Brace-Door Pivot, LH	20	3296-2	2	Nut-Lock, NI
6	103-5774-03	1	Angle-Screen Track, LH	21	32122-30	2	Screw-PTH
7	103-5772-03	1	Bracket-Frame Connect	22	107069	2	Clip
8	103-7035-03	1	Channel-Screen, Front	23	3229-2	4	Screw-CARR
9	109-3650-03	1	Diffuser	24	32105-32	27	Screw-TTH
10	109-0717	1	Hopper Screen ASM	25	103-8800	1	Harness-Wire, Hopper
11	103-8680	1	Deflector-Discharge Chute	26	1-513762	2	Clip-Loom
12	109-4019	2	Plate-Guard	27	103-0205	1	Alarm-Tone, Dual
13	1-543296	1	Grommet	28	130-2885	2	Decal
14	32128-33	33	Nut-HF	29	130-2898-03	2	Plate-Hopper, Side
15	321-2	4	Screw-HH	30	130-8451	20	Rivet-Trifold
16	321-4	5	Screw-HH				

# Hopper Screen Assembly No. 109-0717

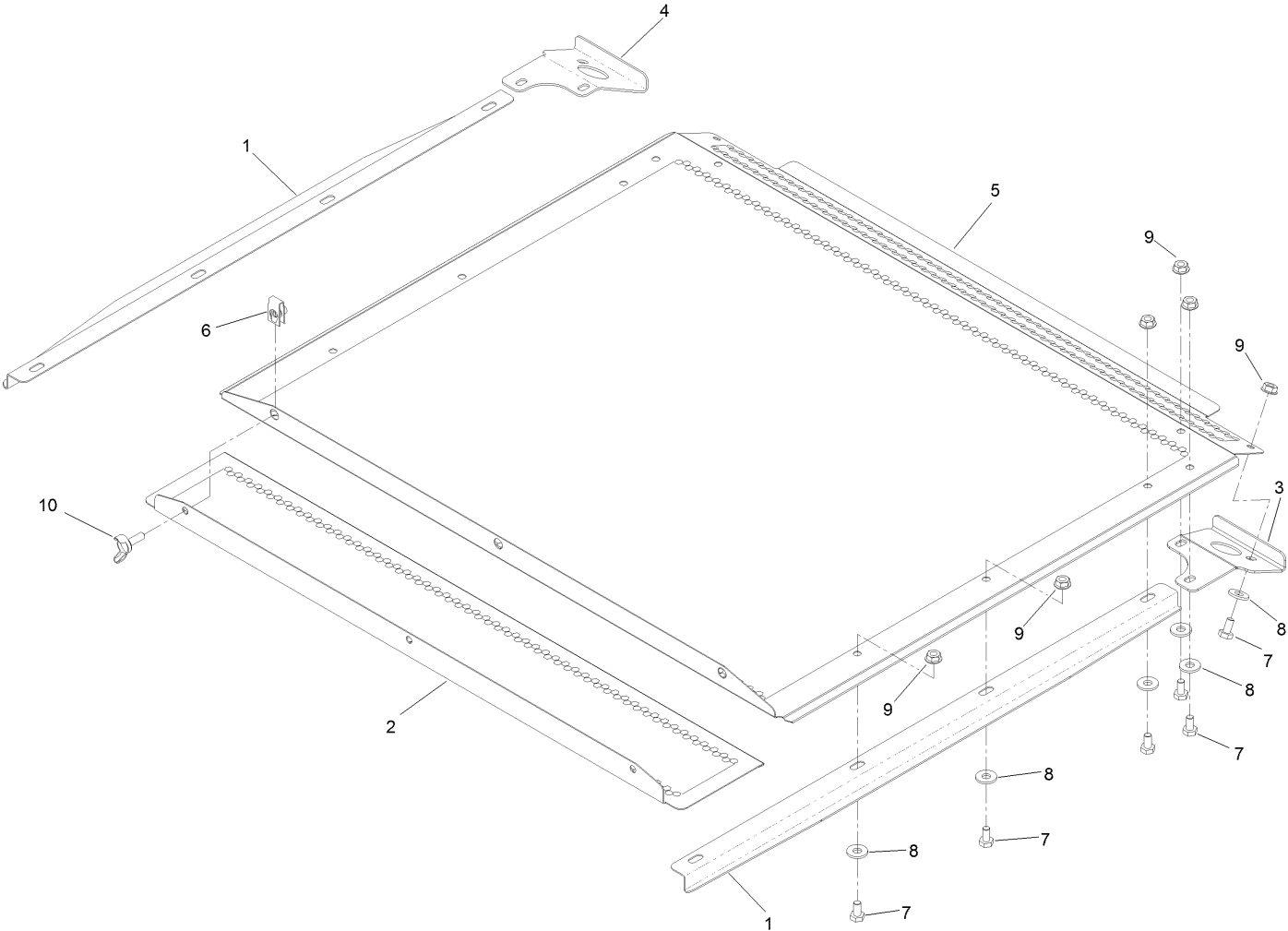

# Hopper Screen Assembly No. 109-0717 (continued)

<i>Ref.</i>	<i>Part Number</i>	<i>Qty.</i>	<i>Description</i>	<i>Ref.</i>	<i>Part Number</i>	<i>Qty.</i>	<i>Description</i>
1	103-8203-03	2	Guide-Screen	6	107069	3	Clip
2	103-7048-03	1	Panel-Screen, Removable	7	321-2	12	Screw-HH
3	103-7098-03	1	Handle-Screen, LH	8	3256-2	12	Washer-Flat
4	103-7099-03	1	Handle-Screen, RH	9	32128-33	12	Nut-HF
5	103-5745-03	1	Panel-Screen, Hopper	10	109-1063	3	Screw-Wing

# Hopper Frame Assembly No. 109-4086

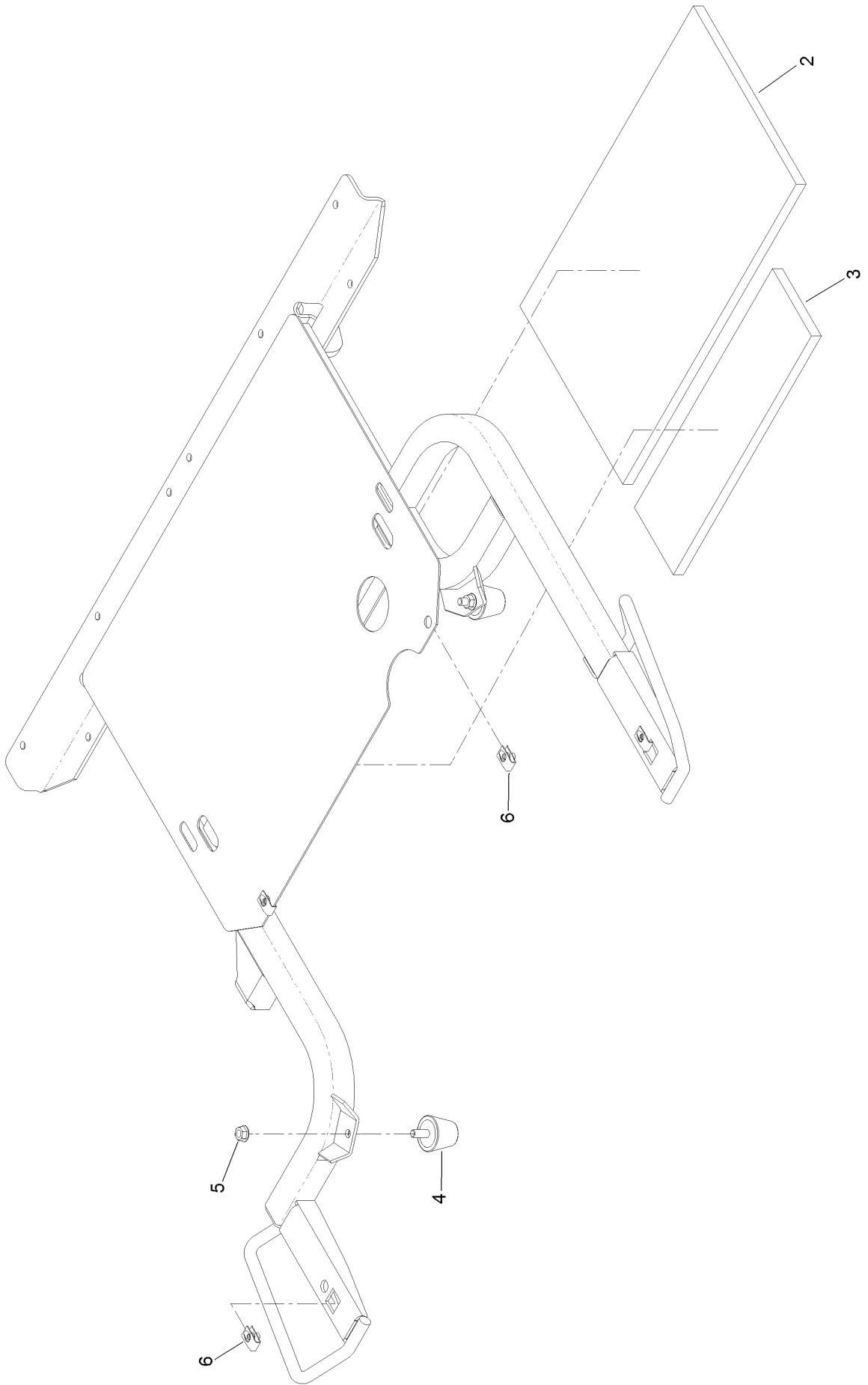

# Hopper Frame Assembly No. 109-4086 (continued)

<i>Ref.</i>	<i>Part Number</i>	<i>Qty.</i>	<i>Description</i>
2	103-7824	1	Insulation-Foam Pad, Rear
3	103-7825	1	Insulation-Foam Pad, Front
4	1-543963	2	Bumper-Rubber

<i>Ref.</i>	<i>Part Number</i>	<i>Qty.</i>	<i>Description</i>
5	32128-20	2	Nut-HF
6	107069	4	Clip

# Drive Assembly

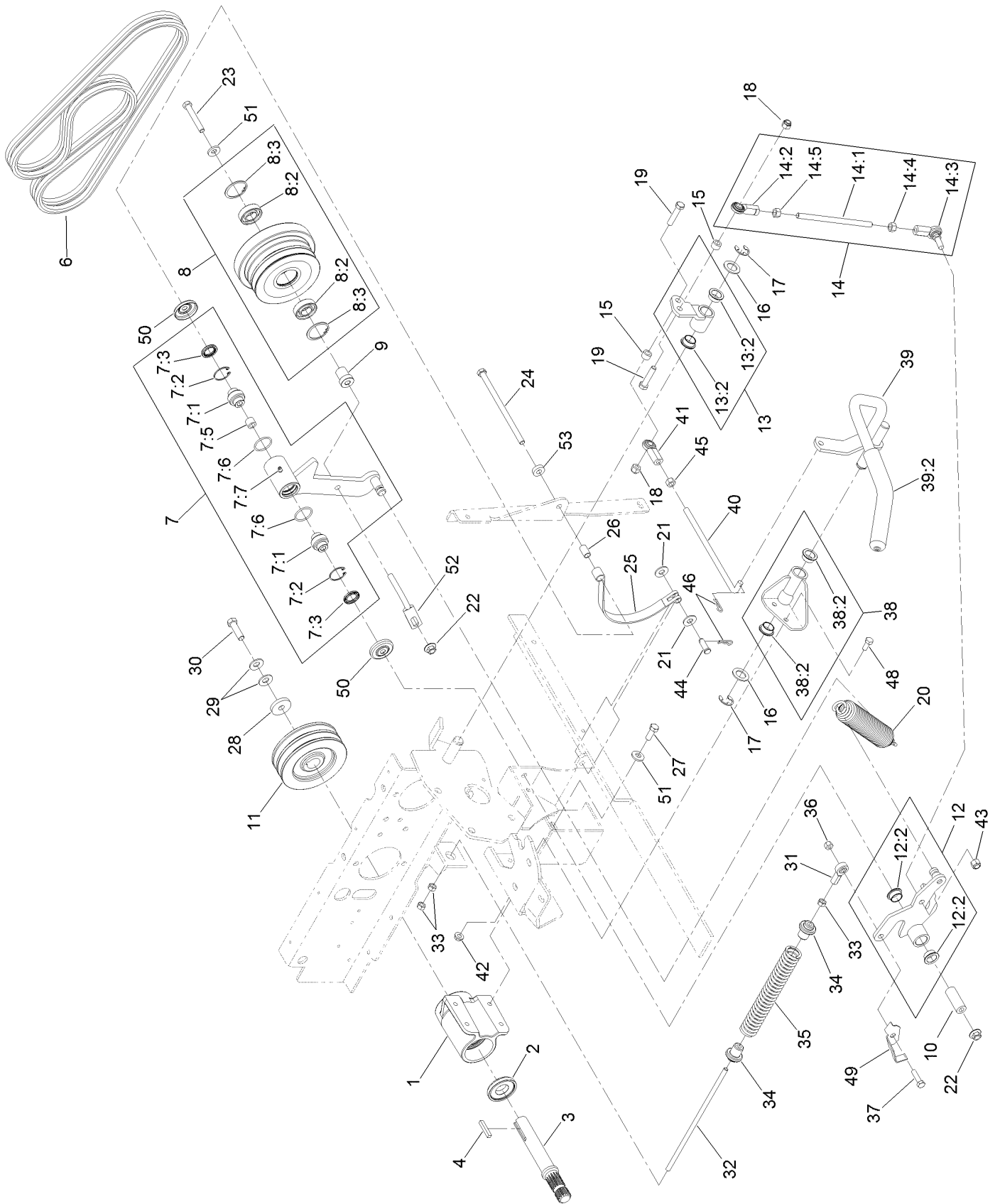



## Drive Assembly (continued)

<i>Ref.</i>	<i>Part Number</i>	<i>Qty.</i>	<i>Description</i>	<i>Ref.</i>	<i>Part Number</i>	<i>Qty.</i>	<i>Description</i>
1	103-2544	1	Jackshaft ASM	21	3256-4	2	Washer-Flat
2	103-2535	1	Spacer-Guard, Bottom	22	32128-19	2	Nut-HF Lock, Large Flg
3	103-6735	1	Jackshaft	23	323-12	1	Screw-HH
4	67-7490	1	Key-Square	24	323-36	1	Screw-HH
6	130-2870	1	Belts-Pair, Matched	25	103-7697	1	Band-Brake
7	103-8253	1	Idler Pivot ASM	26	103-9816	1	Spacer
7:1	103-3504	2	Bearing-Spherical	27	323-6	4	Screw-HH
7:2	32120-10	2	Ring-Snap	28	1-543610	1	Washer-Clutch
7:3	103-3506	2	Seal-Lip, Single	29	1-603610	2	Washer-Spring
7:5	1-413088	1	Bushing-Lever, Lift	30	3212-6	1	Screw-HH
7:6	106-7159	2	O-Ring	31	1-543017	1	Balljoint-RH
7:7	302-19	1	Fitting-Grease	32	103-7996	1	Linkage-Rod, PTO Brake
8	103-9439	1	Idler Sheave ASM	33	3219-2	3	Nut-Hex
8:2	251-347	2	Bearing-Ball	34	103-8254	2	Bushing-Spring
8:3	32151-13	2	Ring-Retaining	35	103-7997	1	Spring-Brake
9	103-7350	1	Spacer-Idler	36	3296-29	1	Nut-Lock, NI
10	103-7382	1	Bushing	37	322-6	1	Screw-HH
11	103-6732	1	Sheave	38	103-9295	1	Pivot ASM
12	103-9296	1	Arm ASM	38:2	108519	2	Bushing-Bronze
12:2	108519	2	Bushing-Bronze	39	103-9486	1	PTO Handle ASM
13	103-9297	1	Arm ASM	39:2	103-8153	1	Grip-Lever, Control
13:2	108519	2	Bushing-Bronze	40	103-8277	1	Link-Handle
14	103-7392	1	Clutch Link ASM	41	103-0608	1	Joint-Ball, End
14:1	103-7393	1	Rod-Linkage	42	32128-20	2	Nut-HF
14:2	103-1167	1	Joint-Ball End, LH	43	3296-6	1	Nut-Lock
14:3	103-7994	1	Balljoint-RH	44	283-2	1	Pin-Clevis
14:4	3219-3	1	Nut-Hex	45	3219-3	1	Nut-Hex
14:5	3219-20	1	Nut-Hex, LH	46	1-806003	2	Pin-Cotter
15	92-9025	2	Spacer	48	322-3	2	Screw-HH
16	1-303007	2	Washer	49	103-8716-03	1	Switch-Flag
17	32151-48	2	E-Ring	50	103-2916	2	Guard-Top
18	3296-39	2	Nut-Lock, NI	51	98-5975	5	Washer-Belleville
19	323-9	2	Screw-HH	52	109-5491	1	Guide-Belt
20	109-0148	1	Spring-Extension	53	5-0652	1	Spacer

# Deck Assembly

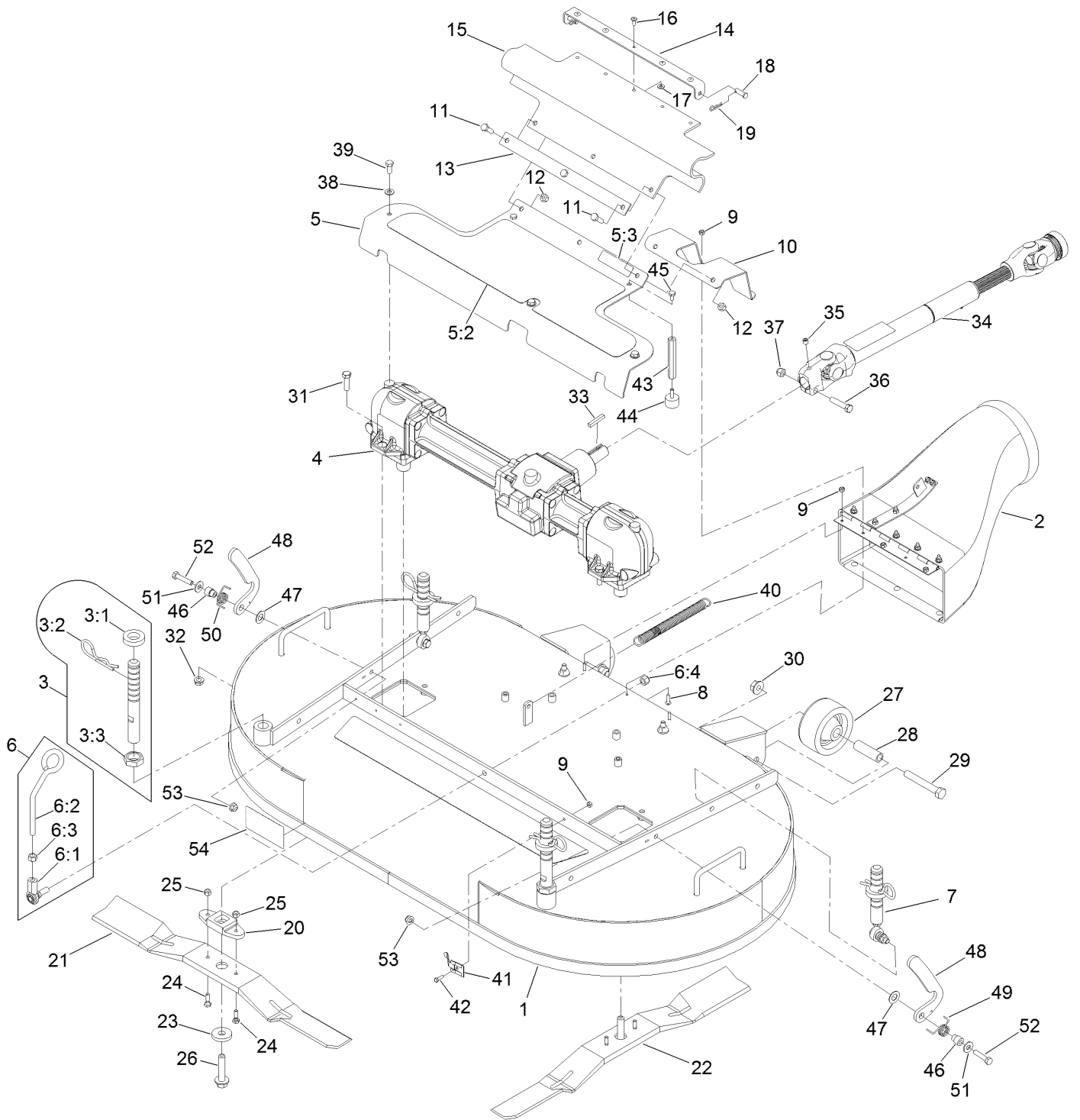

## Deck Assembly (continued)

<i>Ref.</i>	<i>Part Number</i>	<i>Qty.</i>	<i>Description</i>	<i>Ref.</i>	<i>Part Number</i>	<i>Qty.</i>	<i>Description</i>
1	142-2922	1	Deck-Cutting 48 W/Decals	23	30-8770	2	Washer
2	103-9487	1	Discharge Tube ASM	24	99-0283	4	Bolt-Shear
3	109-0321	2	Front Deck Height Adjust ASM	25	3296-42	4	Nut-Lock, NI
3:1	1-413425	1	Spacer-Deck Support	26	92-5816	2	Bolt-Blade
3:2	103-7353	1	Pin-Cut Height	27	103-3700	2	Roller-Deck
3:3	103-8496	1	Nut-Jam	28	103-4230	2	Spacer-Roller
4	103-3387	1	Gear Box ASM	29	325-14	2	Screw-HH
5	130-2899	1	Gearbox Cover ASM	30	32128-49	2	Nut-HHF
5:2	103-8629	1	Pad-Anti Skid	31	323-7	4	Screw-HH
5:3	119-0217	1	Decal-Danger	32	3290-357	4	Nut-HSF
6	103-8363	1	Deck Latch ASM	33	67-7490	1	Key-Square
6:1	103-7994	1	Balljoint-RH	34	103-9485	1	Drive Shaft ASM
6:2	103-8307	1	Latch-Deck	35	3247-2	1	Screw-Set, HSH
6:3	3219-3	1	Nut-Hex	36	323-9	1	Screw-HH
6:4	3296-6	1	Nut-Lock	37	3296-39	1	Nut-Lock, NI
7	109-0323	2	Rear Deck Height Adjust ASM	38	3256-23	3	Washer-Plain
8	1-803075	3	Screw-Head, Truss	39	322-3	3	Screw-HH
9	3296-2	6	Nut-Lock, NI	40	103-8841	1	Spring-Extension
10	116-7843-01	1	Guard-Drive Shaft	41	1-513690	1	Clip-Deck, Hold Up Rod
11	322-5	3	Screw-HH	42	3290-134	1	Screw
12	3296-29	3	Nut-Lock, NI	43	103-8610	2	Stand-Off
13	103-6290-03	1	Strap-Drive, Line Cover	44	1-523420	2	Bumper
14	103-6183-03	1	Bracket-Guard, PTO	45	321-2	2	Screw-HH
15	103-5979	1	Guard-PTO	46	108-9087	2	Collar-Basket
16	114439	5	Rivet-Blind	47	110-4068	2	Washer-Plastic
17	3256-14	5	Washer-Flat	48	142-2475	2	Latch - Deck
18	1-808280	2	Pin-Clevis	49	75-3960	1	Spring-Torsion, LH (Yellow)
19	1-806003	2	Pin-Cotter	50	75-3970	1	Spring-Torsion, RH
20	103-7705	2	Driver-Blade	51	3256-3	2	Washer-Flat
21	130-2862	1	Blade-25In, RH	52	322-7	2	Screw-HH
22	130-2861	1	Blade-25In, LH	53	104-8300	2	Nut-HF, NI
				54	130-2887	1	Decal

# Deck Decal Assembly No. 142-2922

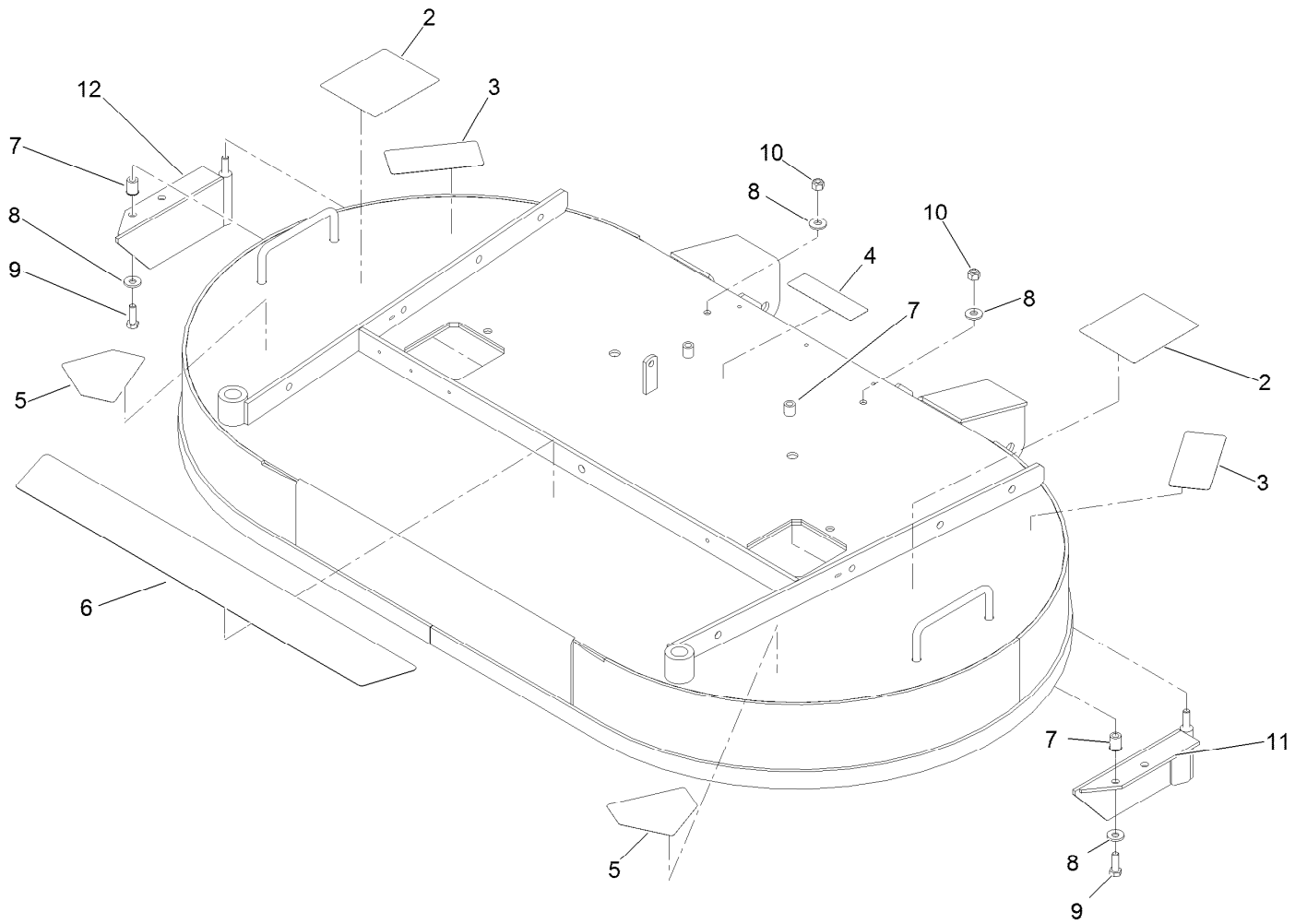

## Deck Decal Assembly No. 142-2922 (continued)

<i>Ref.</i>	<i>Part Number</i>	<i>Qty.</i>	<i>Description</i>	<i>Ref.</i>	<i>Part Number</i>	<i>Qty.</i>	<i>Description</i>
2	116-8934	2	Decal-Height Adjust, Cutting	8	1-303334	4	Washer-Spring Disc 5/16
3	93-7818	2	Decal-Torque, Blade Bolt	9	322-5	2	Screw-HH 5/16-18 X 1
4	112-9028	1	Decal-Cover, Missing	10	3296-29	2	Nut-Nyloc 5/16-18
5	112-8760	2	Decal-Danger	11	109-4053-01	1	Baffle-LH
6	103-8630	1	Pad-Anti Skid	12	109-4054-01	1	Baffle-RH
7	32148-7	4	Nut-Clinch				

# Discharge Tube Assembly No. 103-9487

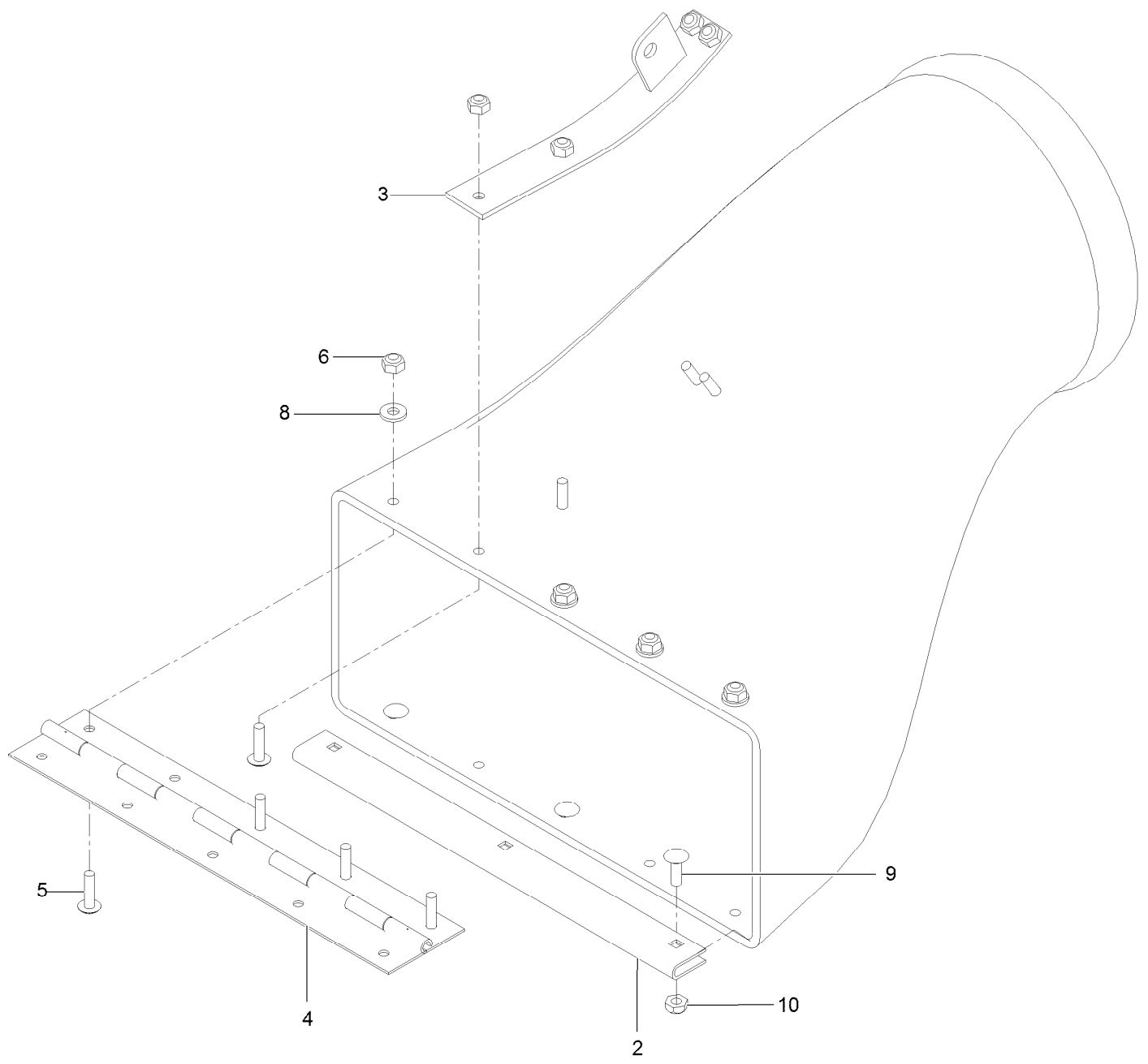

## Discharge Tube Assembly No. 103-9487 (continued)

<i>Ref.</i>	<i>Part Number</i>	<i>Qty.</i>	<i>Description</i>	<i>Ref.</i>	<i>Part Number</i>	<i>Qty.</i>	<i>Description</i>
2	109-2228-03	1	Guard-Plenum	6	3296-2	8	Nut-Lock, NI
3	103-5868-01	1	Mount-Spring	8	3256-14	4	Washer-Flat
4	139-4460	1	Hinge-Piano	9	1-807533	3	Bolt-CARR
5	1-803075	8	Screw-Head, Truss	10	3296-12	3	Nut-Lock, NI

# Gearbox Assembly No. 103-3387

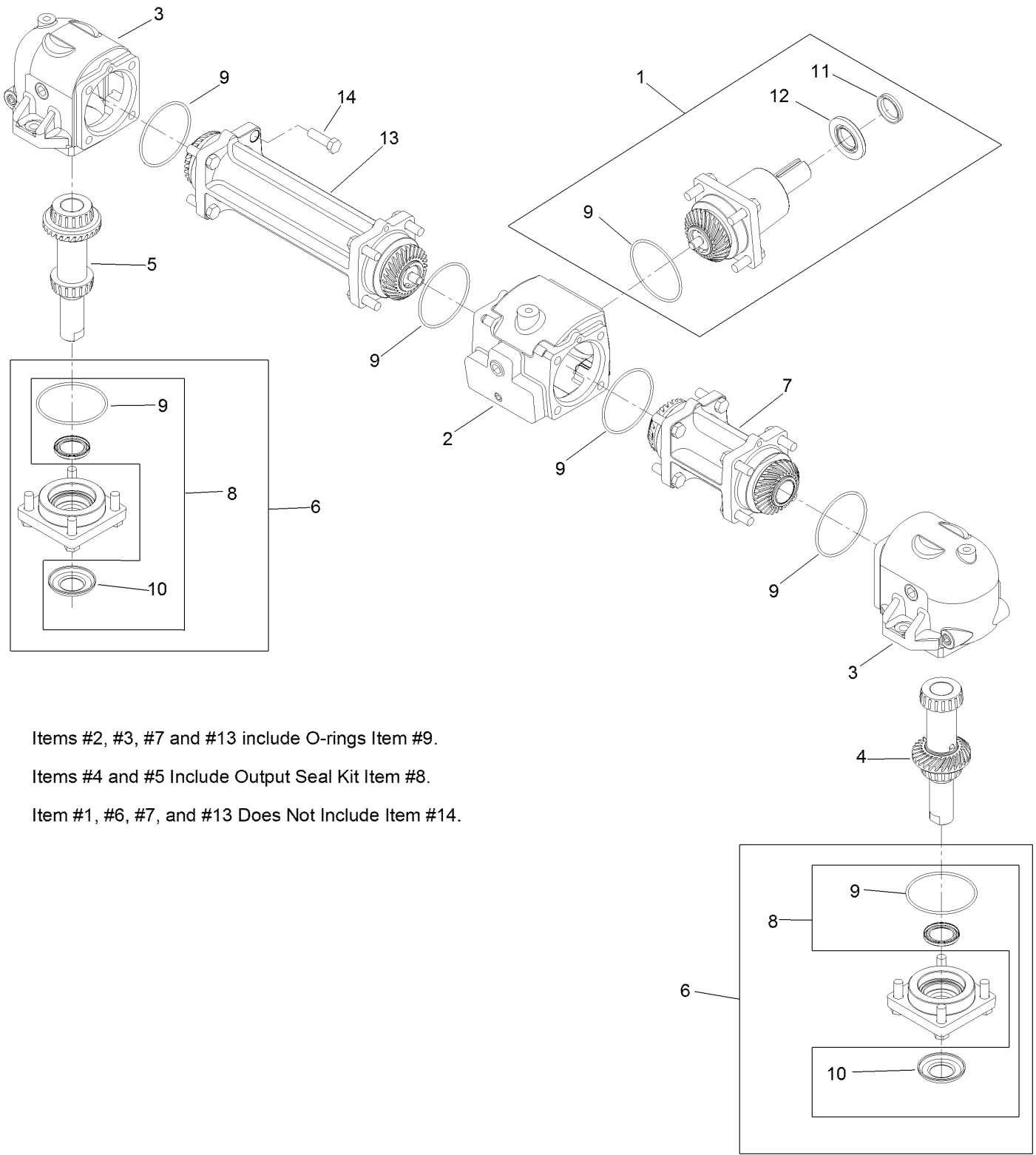

Items #2, #3, #7 and #13 include O-rings Item #9.

Items #4 and #5 Include Output Seal Kit Item #8.

Item #1, #6, #7, and #13 Does Not Include Item #14.



## Gearbox Assembly No. 103-3387 (continued)

<i>Ref.</i>	<i>Part Number</i>	<i>Qty.</i>	<i>Description</i>	<i>Ref.</i>	<i>Part Number</i>	<i>Qty.</i>	<i>Description</i>
1	109-0189	1	Pinion-Input	8	109-0201	1	Output Seal Kit
2	109-0190	1	Housing-Center	9	109-0203	1	Seal-O-Ring
3	109-0191	1	Housing-End	10	109-0204	1	Washer-Cupped
4	109-0193	1	Output Shaft And Gear-LH	11	109-0205	1	Seal-V-Ring ●
5	109-0195	1	Output Shaft And Gear-RH	12	109-0202	1	Seal-Input ●
6	109-0196	1	Cap-Output	13	109-0200	1	Connector-Tube, Long
7	109-0198	1	Tube-Connector, Shor	14	93-3987	28	Bolt-Blade

● Apply bead of Mobil HTS grease (P/N 103-5217 1.5 oz packet) (or a food-grade anti-seize) between input seal and v-ring.

# Rear Deck Height Adjustment Assembly No. 109-0323

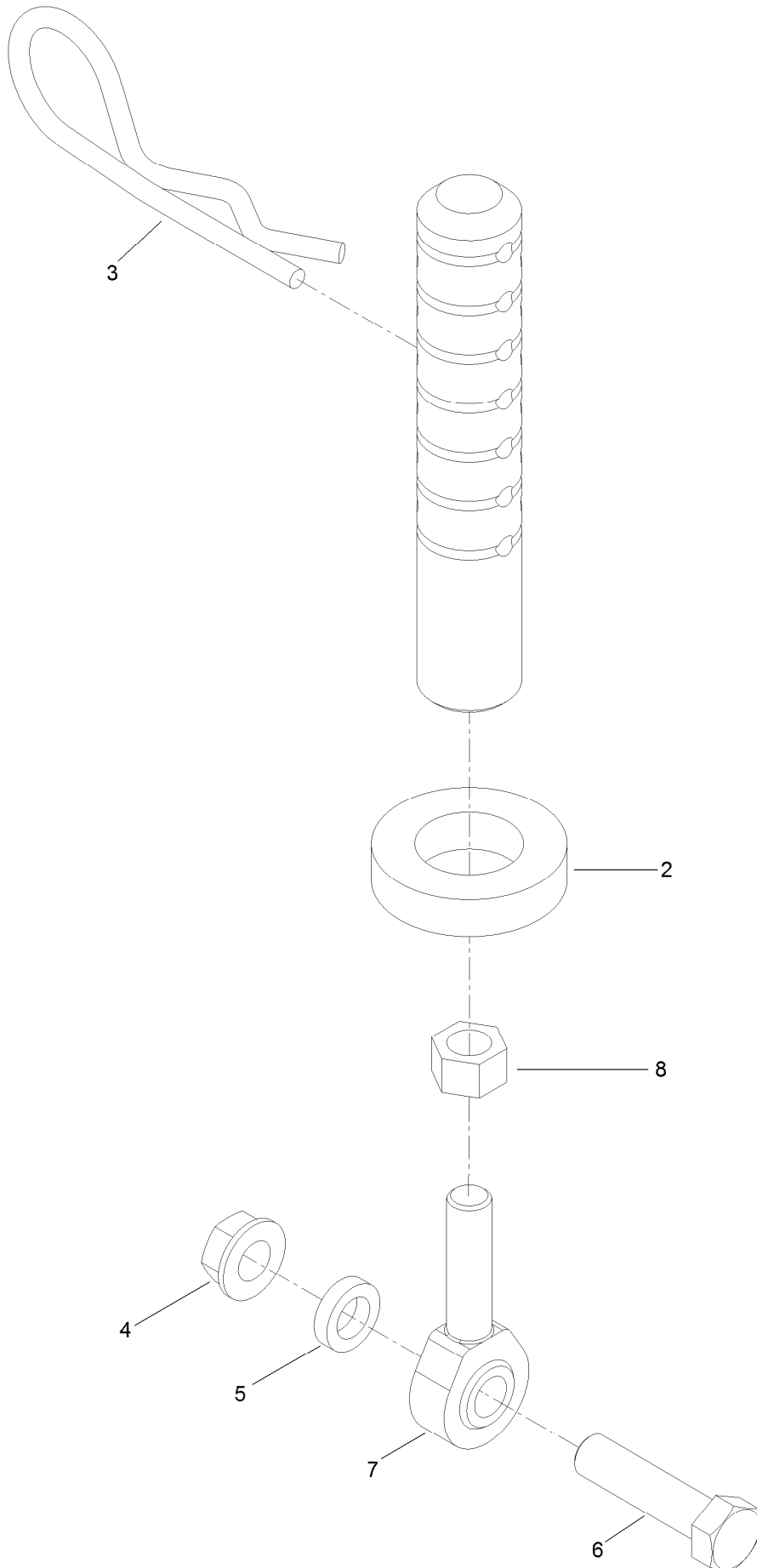

## Rear Deck Height Adjustment Assembly No. 109-0323 (continued)

<i>Ref.</i>	<i>Part Number</i>	<i>Qty.</i>	<i>Description</i>	<i>Ref.</i>	<i>Part Number</i>	<i>Qty.</i>	<i>Description</i>
2	1-413425	1	Spacer-Deck Support	6	323-8	1	Screw-HH
3	103-7353	1	Pin-Cut Height	7	1-613204	1	Balljoint
4	3290-357	1	Nut-HSF	8	3220-3	1	Nut-HJ
5	106-5597	1	Spacer-Idler				

# Drive Shaft Assembly No. 103-9485

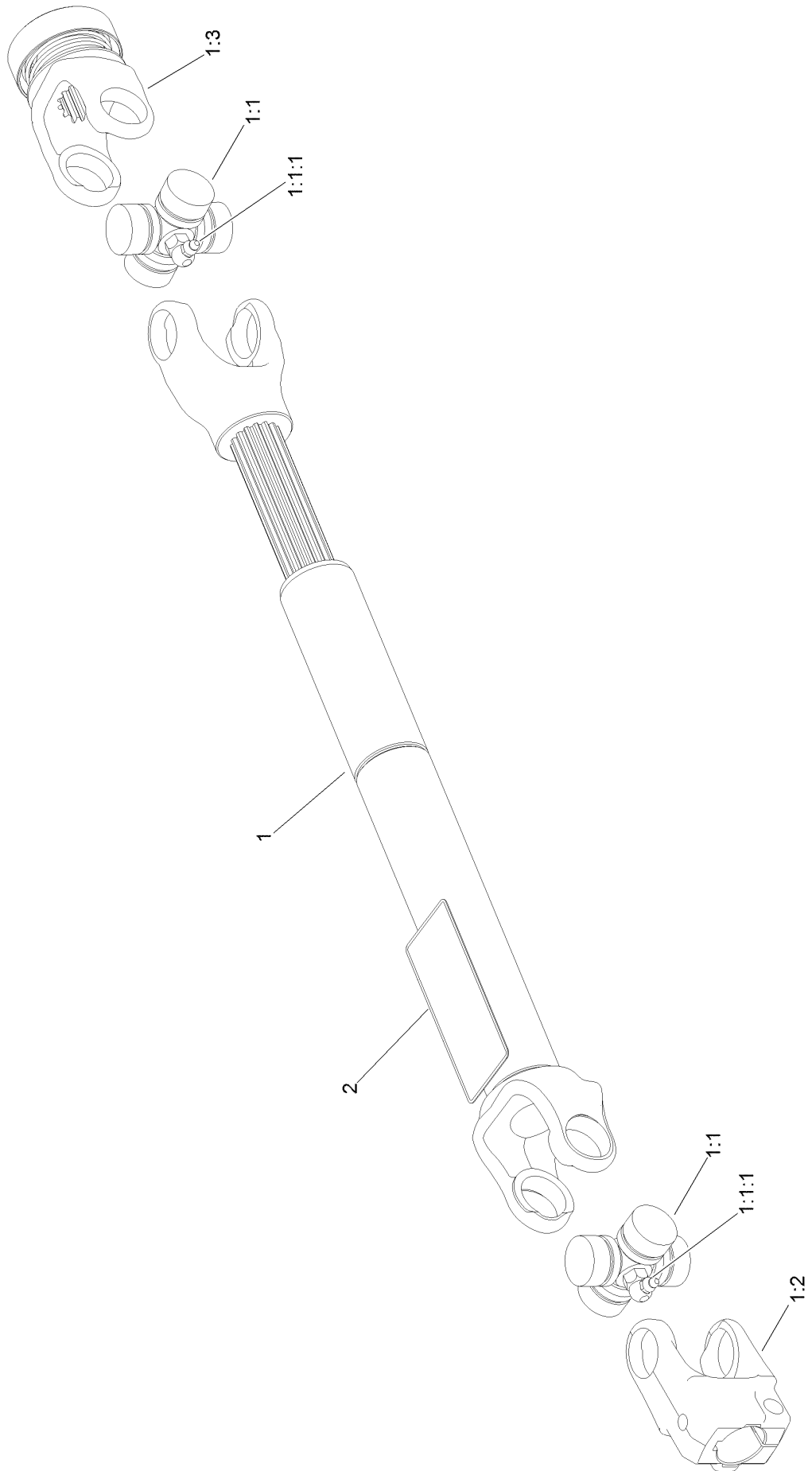

## Drive Shaft Assembly No. 103-9485 (continued)

<i>Ref.</i>	<i>Part Number</i>	<i>Qty.</i>	<i>Description</i>	<i>Ref.</i>	<i>Part Number</i>	<i>Qty.</i>	<i>Description</i>
1		1	Drive Shaft-Telescoping ●	1:2	103-9328	1	Yoke-Keyed
1:1	54-9180	2	U-Joint Kit	1:3	103-9329	1	Yoke-Quick Disconnect
1:1:1	62-3820	1	Fitting-Grease	2	116-9049	1	Decal-Danger, Driveline

● Not serviced separately

# Deck Support Frame Assembly No. 142-2995

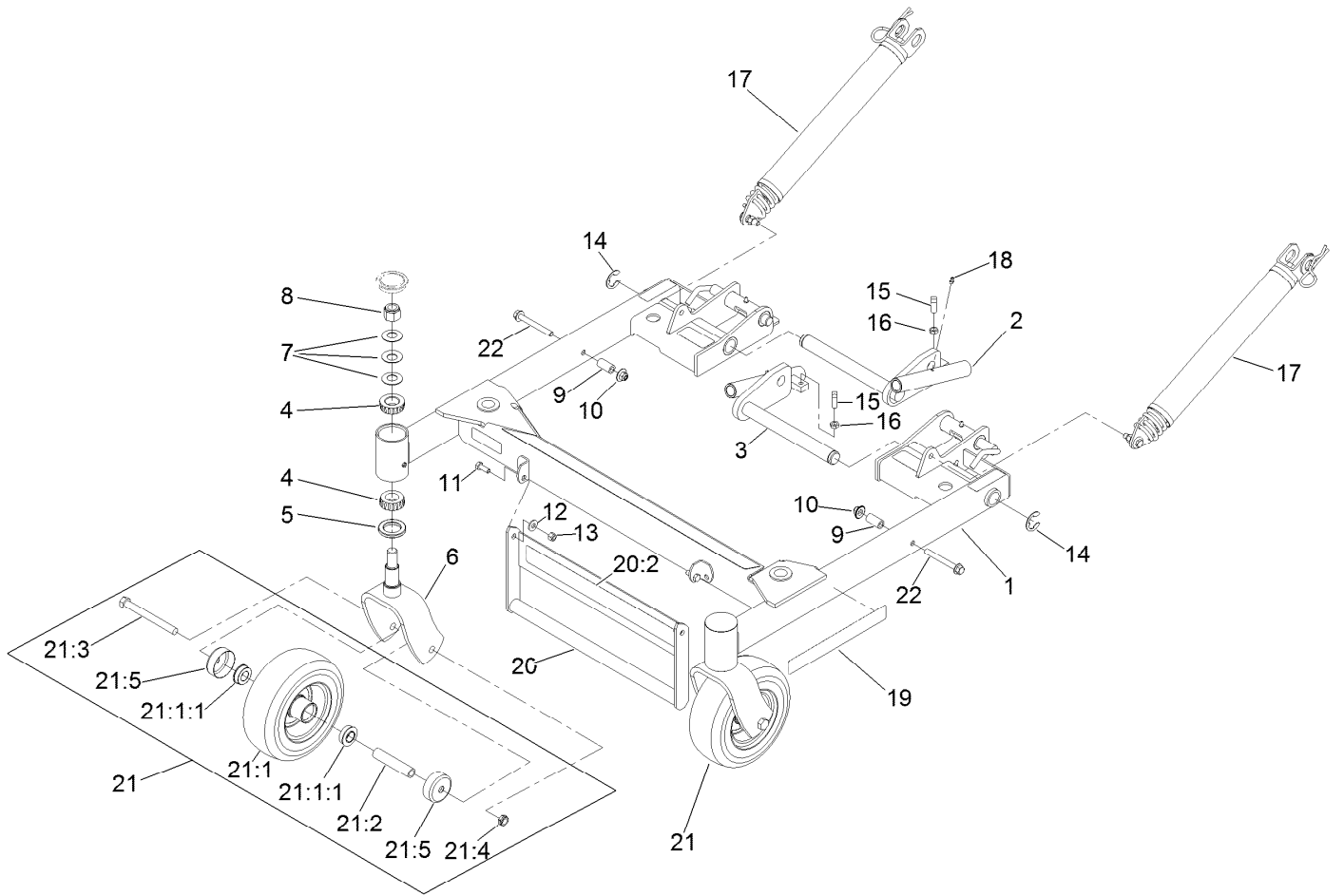

## Deck Support Frame Assembly No. 142-2995 (continued)

<i>Ref.</i>	<i>Part Number</i>	<i>Qty.</i>	<i>Description</i>	<i>Ref.</i>	<i>Part Number</i>	<i>Qty.</i>	<i>Description</i>
1	142-2914	1	Frame-Deck Support W/Decals	15	3243-5	2	Screw-Set, SQH
2	103-3729-01	1	Pivot-Deck, RH	16	3218-3	2	Nut-Jam
3	103-3732-01	1	Pivot-Deck, LH	17	116-7851	2	Lift Assist Spring ASM
4	1-543509	4	Bearing-Roller, Tapered	18	302-19	2	Fitting-Grease
5	1-543511	2	Seal-Grease	19	130-2884	2	Decal
6	109-1933-01	2	Fork-Caster	20	130-2897	1	Deck Lift Handle ASM
7	1-633508	6	Washer-Bellville	20:2	130-2883	1	Decal
8	3296-51	2	Nut-Lock, NI	21	135-5967	2	Wheel And Axle ASM
9	108-6544	2	Spacer	21:1	135-5964	1	Wheel And Tire ASM
10	109-6658	2	Nut-Flange, NI	21:1:1	135-5963	2	Bearing-Ball
11	322-4	2	Screw-HH	21:2	109-2094	1	Spacer-Caster, Front
12	1-303334	2	Washer-Spring	21:3	325-19	1	Screw-HH
13	3296-29	2	Nut-Lock, NI	21:4	3296-45	1	Nut-Hex
14	1-808519	2	Ring-Snap	21:5	103-2768	2	Guard-Seal
				22	3234-41	2	Screw-HHF

# Deck Support W/Decals Assembly No. 142-2914

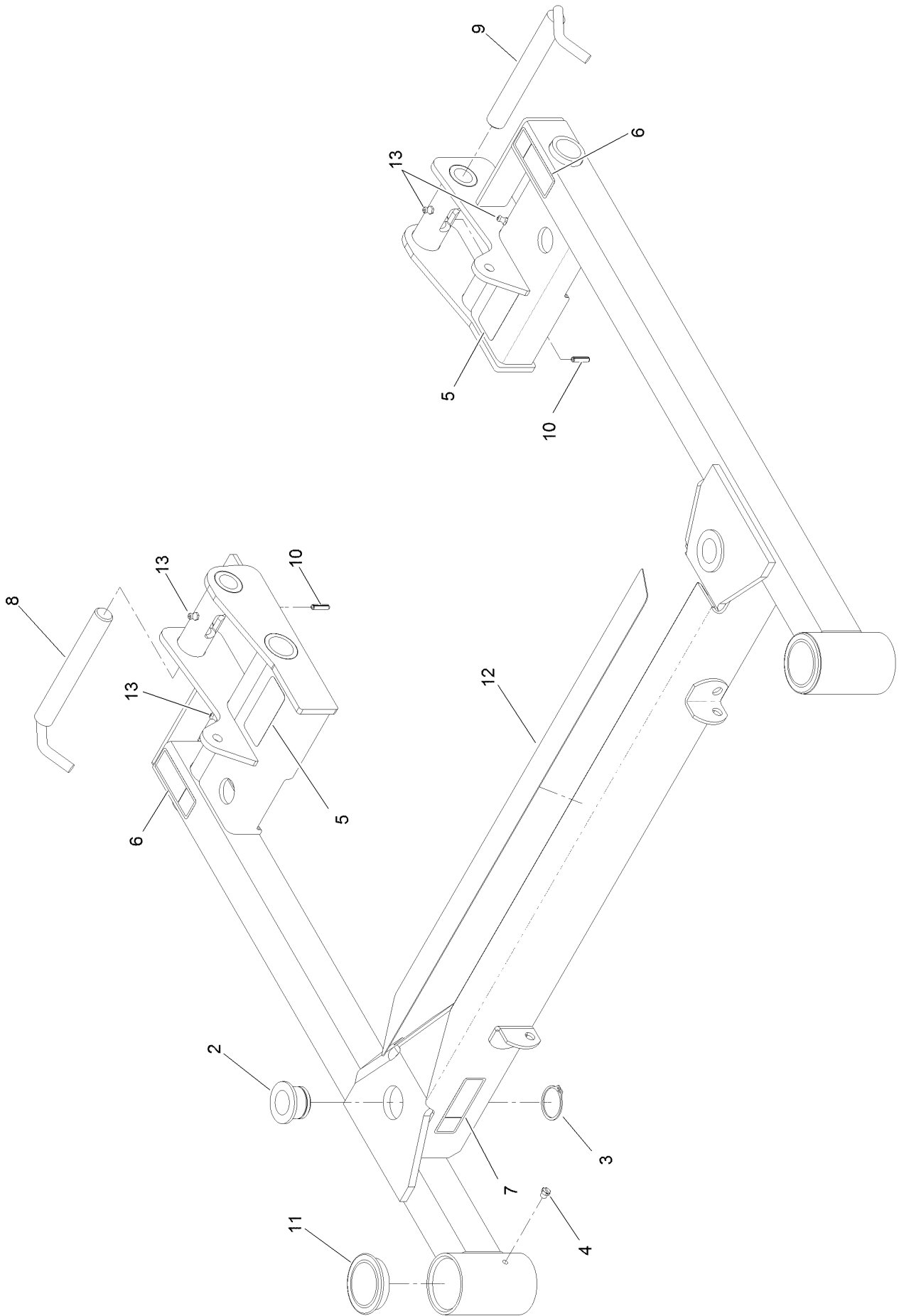



## Deck Support W/Decals Assembly No. 142-2914 (continued)

<i>Ref.</i>	<i>Part Number</i>	<i>Qty.</i>	<i>Description</i>	<i>Ref.</i>	<i>Part Number</i>	<i>Qty.</i>	<i>Description</i>
2	103-7436	2	Bushing-Support, Deck	8	103-4119	1	Lock-Deck, RH
3	32120-33	2	Ring-Retaining	9	103-4118	1	Lock-Deck, LH
4	1-811010	2	Plug	10	32121-3	2	Pin-Spring
5	93-6696	2	Decal-Warning	11	103-4882	2	Cap-Grease
6	116-8935	2	Decal-Warning, Folding Deck	12	103-8630	1	Pad-Anti Skid
7	116-8936	1	Decal-Danger	13	302-19	4	Fitting-Grease

# Lift Assist Spring Assembly No. 116-7851

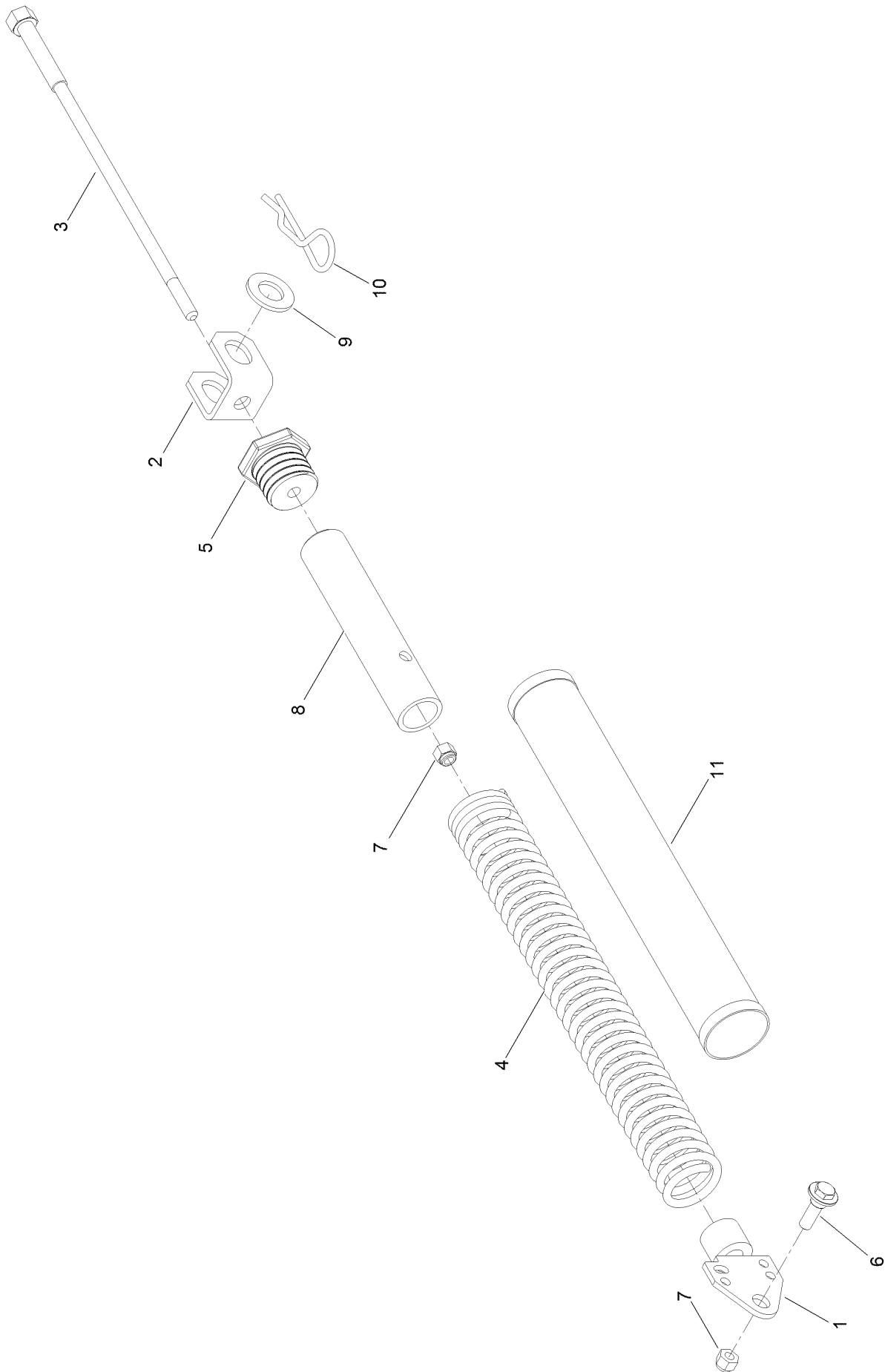

# Lift Assist Spring Assembly No. 116-7851 (continued)

<i>Ref.</i>	<i>Part Number</i>	<i>Qty.</i>	<i>Description</i>	<i>Ref.</i>	<i>Part Number</i>	<i>Qty.</i>	<i>Description</i>
1	103-4284	1	Tensioner-Spring	7	3296-39	2	Nut-Lock, NI
2	103-4285	1	Mount-Lift Assist, Deck	8	103-7865	1	Spring-Tube
3	103-3773	1	Shaft-Adjustment, Spring	9	3256-28	1	Washer-Flat
4	103-4281	1	Spring-Extension	10	103-7353	1	Pin-Cut Height
5	103-3772	1	Plug-Adjuster, Spring	11	103-7971	1	Cover-Spring, Deck
6	614672	1	Screw-Shoulder, HWH				

# Attachments and Accessories

## For 74312 Z Master 8000 Series Riding Mower with 48in Cutting Unit

<b>Product Name</b>	<b>Model/Part</b>
Winter Hydraulic Filter .....	1-633752
Hypr-Oil 500 (quart) .....	114-4713
Hypr-Oil 500 (gallon).....	114-4714
Hypr-Oil 500-5 (5 gallon).....	114-4715
ROPS Pin Kit .....	126-1339
Dual Split Caster Kit.....	130-8455
Removable Grass Tubs Kit .....	130-8457
Hopper Power Dump Kit .....	130-8458
ROPS Kit .....	130-8459
48in Mulch Kit .....	130-8463
25in LH Mulching Blade .....	130-8464
25in DH Mulching Blade .....	130-8465
MVP Kit.....	130-8468
Light Kit.....	130-8469
Automatic Door Opener Kit.....	130-8470
Suspension Seat Kit .....	130-8471
Hopper Latch Kit.....	130-8488

**Notes:**

**Notes:**

**Notes:**



**Count on it.**