



**Count on it.**

**Parts Catalog**

**Grapple**

**TXL 2000 Tool Carrier**

Model No. 22535—Serial No. 318000001 and Up



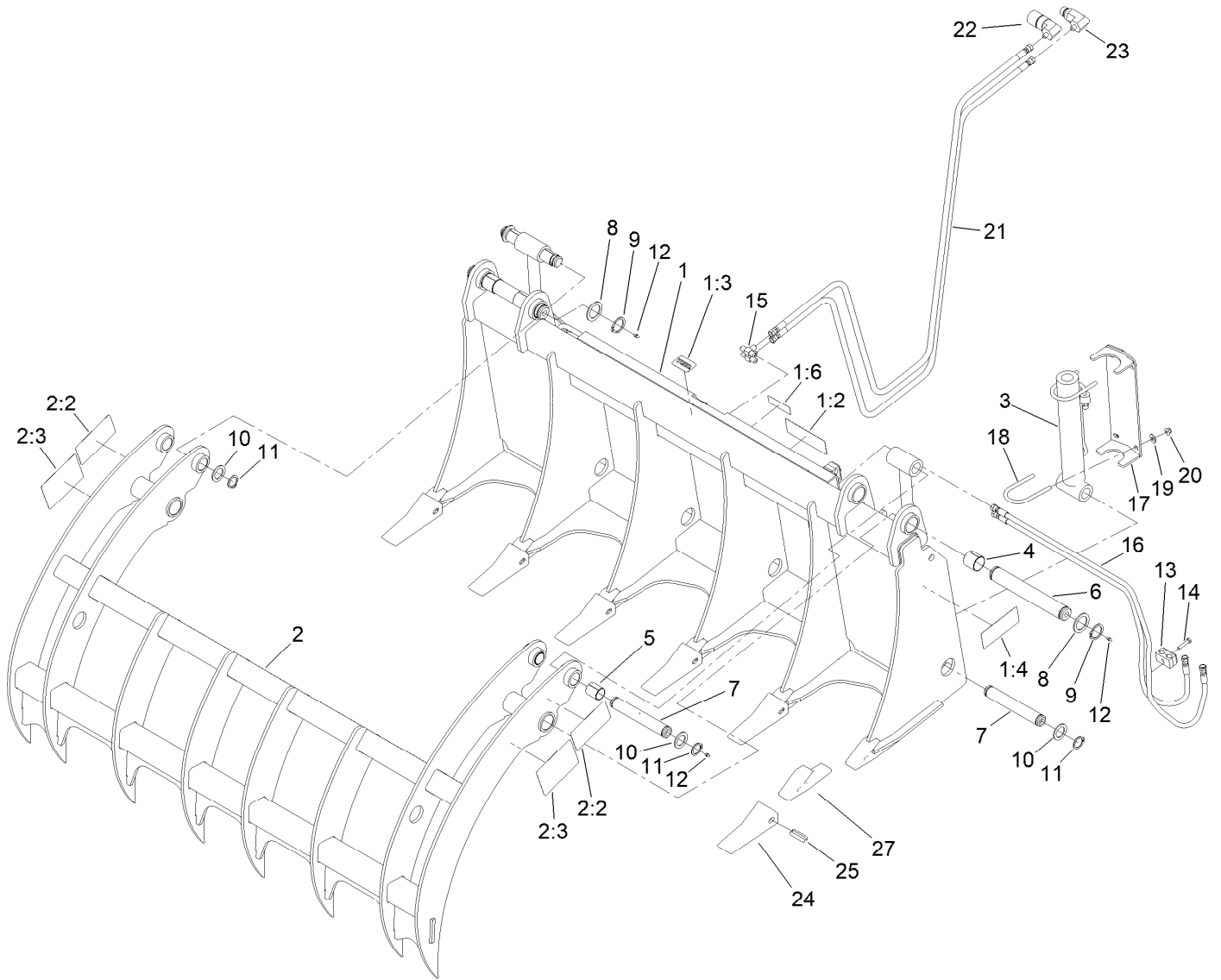

## Grapple Assembly

Ref.	Part Number	Qty.	Description	Ref.	Part Number	Qty.	Description
1	139-2774	1	Bucket Frame ASM	11	32151-77	8	Ring-Retaining, External
1:2	139-2842	1	Decal-Capacity	12	137-9002	8	Fitting-Zerk
1:3	98-3206	1	Decal	13	137-8904	4	Clamp-Hose
1:4	125-6128	1	Decal-Warning	14	322-7	4	Screw-HH
1:6	138-4188	1	Decal	15	137-8912	2	Fitting-Tee
2	139-2775	1	Jaw ASM	16	139-1379	4	Hose-HYD
2:2	138-0544	2	Decal-Danger, Crush	17	138-1365	2	Guard-Cylinder
2:3	138-0537	2	Decal-Danger, Grapple	18	138-1366	4	U-Link
3	137-8990	2	Hydraulic Cylinder ASM	19	3256-4	8	Washer-Flat
3:1	139-1401	1	Seal Kit ●	20	104-8301	8	Nut-HF, NI
4	137-4897	8	Bushing	21	138-5199	2	Hose-HYD
5	137-4896	4	Bushing	22	137-8914	1	Fitting-Elbow
6	137-4894	2	Pin-Hinge	23	137-8915	1	Fitting-Elbow
7	137-3895	4	Pin-Pivot	24	137-4893	6	Tooth-Cast
8	137-4898	4	Washer	25	137-4899	6	Pin-Flex
9	137-8900	4	Ring-Snap, External	27	145-1162	6	Shank-Tooth, Weld-On
10	137-3897	8	Washer				

● Not illustrated