



Debris Blower 600

Model No. 44536—Serial No. 220000001 and Up

Operator's Manual

Contents

Contents	2
Introduction	2
Safety	3
Before Operating	3
While Operating	3
Maintenance	3
Safety and Instruction Decals	4
Specifications	6
General Specifications	6
Optional Equipment	6
Setup	7
Ballast Requirements	7
Install Castor Wheels	7
Connecting the Lower Link Arms	7
Connecting the Upper Link	8
Adjusting the PTO Shaft Length	8
Connecting the PTO Shaft	9
Adjusting the Sway Links	9
Adjusting the 3 Point Lift Stop	9
Removing the Blower from the Tractor	10
Greasing the Blower	10
Operation	11
Operating Tips	11
Adjusting Discharge Direction	11
Maintenance	12
Greasing the Blower	12
Adjusting the Blower Belt	13
Troubleshooting	14
Storage	15
The Toro General Commercial Products Warranty ..	16

Introduction

Read this manual carefully to learn how to operate and maintain your product properly. The information in this manual can help you and others avoid injury and product damage. Although Toro designs and produces safe products, you are responsible for operating the product properly and safely.

Whenever you need service, genuine Toro parts, or additional information, contact an Authorized Service Dealer or Toro Customer Service and have the model and serial numbers of your product ready. The two numbers are stamped on a plate which is located on the blower housing.

Write the product model and serial numbers in the space below:

<p>Model No. _____</p> <p>Serial No. _____</p>
--

This manual identifies potential hazards and has special safety messages that help you and others avoid personal injury and even death. **Danger**, **Warning**, and **Caution** are signal words used to identify the level of hazard. However, regardless of the hazard, be extremely careful.

Danger signals an extreme hazard that *will* cause serious injury or death if you do not follow the recommended precautions.

Warning signals a hazard that *may* cause serious injury or death if you do not follow the recommended precautions.

Caution signals a hazard that may cause minor or moderate injury if you do not follow the recommended precautions.

This manual uses two other words to highlight information. **Important** calls attention to special mechanical information and **Note**: emphasizes general information worthy of special attention.

Safety

Hazard control and accident prevention are dependent upon the awareness, concern, and proper training of the personnel involved in the operation, transport, maintenance, and storage of the machine. Improper use or maintenance of the machine can result in injury or death. To reduce the potential for injury or death, comply with the following safety instructions.

Before Operating

- Read and understand the contents of this Operator's Manual before operating the machine. Become familiar with all of the controls and know how to stop quickly. A free replacement manual is available by sending the complete Model and Serial Number to The Toro Company, 8111 Lyndale Avenue South, Bloomington, Minnesota 55420-1196.
- Never allow children to operate the machine. Do not allow adults to operate machine without proper instruction. Only trained operators who have read this manual should operate this machine.
- Never operate the machine when under the influence of drugs or alcohol.
- Keep all bystanders away from the operating area.
- Keep all shields and safety devices in place. If a shield, safety device, or decal is illegible or damaged, repair or replace it before operation is commenced. Also tighten any loose nuts, bolts, and screws to ensure that the machine is in safe operating condition.
- Do not operate the machine while wearing sandals, tennis shoes, sneakers, or shorts. Also, do not wear loose fitting clothing which could get caught in moving parts. Always wear long pants and substantial shoes. Wearing safety glasses, safety shoes, and a helmet is advisable and required by some local ordinances and insurance regulations.

While Operating

- This product may exceed noise levels of 85 dB(A) at the operator position. Ear protectors are recommended for prolonged exposure to reduce the potential of permanent hearing damage.
- Using the machine demands attention. To prevent loss of control:
 - Operate only in daylight or when there is good artificial light.
 - Drive slowly and watch for holes or other hidden hazards.
 - Do not drive close to a sand trap, ditch, creek, or other hazard.

- Reduce your speed when making sharp turns and when turning on hillsides.
- Avoid sudden starts and stops.
- Before backing up, look to the rear and ensure that no one is behind the machine.
- Watch out for traffic when near or crossing roads. Always yield the right-of-way.
- Stay away from the discharge opening when the machine is operating. Keep all bystanders away from the discharge opening and don't direct discharge toward bystanders.
- If the engine stalls or the machine loses headway and cannot make it to the top of a slope, do not turn the machine around. Always back slowly straight down the slope.
- **Do not take an injury risk!** When a person or pet appears unexpectedly in or near the operating area, **stop operation**. Careless operation, combined with terrain angles, ricochets, or improperly positioned guards can lead to thrown object injuries. Do not resume operation until the area is cleared.
 - A. Lower the blower to the ground and remove the key from the ignition switch whenever the machine is left unattended.

Maintenance

- Remove the key from the ignition switch to prevent accidental starting of the engine when servicing, adjusting, or storing the machine.
- Perform only those maintenance instructions described in this manual. If major repairs are ever needed or assistance is desired, contact an Authorized Toro Distributor.
- Be sure that the machine is in safe operating condition by keeping nuts, bolts, and screws tight. Check all bolts and nuts frequently to be sure that they are tightened to specification.
- To ensure optimum performance and safety, always purchase genuine Toro replacement parts and accessories to keep the machine all Toro. **Never use "will-fit" replacement parts and accessories made by other manufacturers.** Look for the Toro logo to ensure genuineness. Using unapproved replacement parts and accessories could void the warranty.

Safety and Instruction Decals



Safety decals and instructions are easily visible to the operator and are located near any area of potential danger. Replace any decal that is damaged or lost.



98-3110

- | | |
|---|---|
| 1. Danger—See Operator's Manual | 4. Always wear eye protection |
| 2. Danger—Wear ear protection | 5. Cutting hazard to hands or feet—wait until all machine components have stopped before touching them. |
| 3. Thrown object hazard—Keep bystanders away. | |



92-7937



92-7936

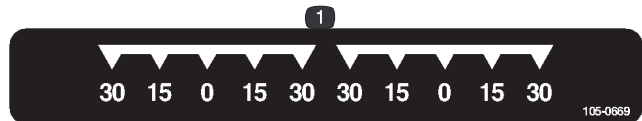

105-0669

1. Belt tension indicator



98-3110

1. Danger—See Operator's Manual

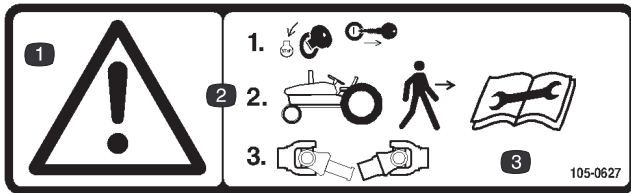

105-0627

1. Danger
2. Stop the engine and remove the key from tractor ignition before leaving operator's position. Disconnect PTO shaft.
3. Read Operator's Manual before performing any maintenance on machine

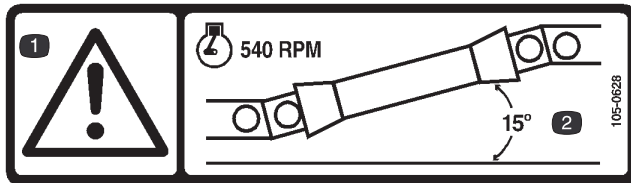

105-0628

1. Danger
2. Do not operate machine with PTO shaft at a greater angle than 15°

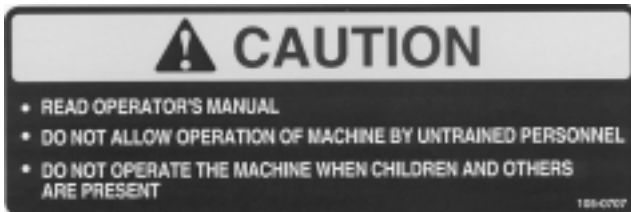

105-0707

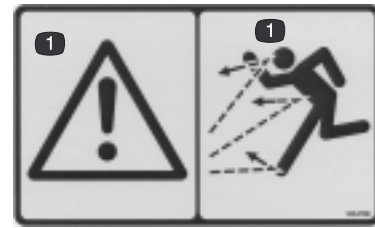

105-0708

1. Danger-Blown object hazard-Keep bystanders away chute outlet.

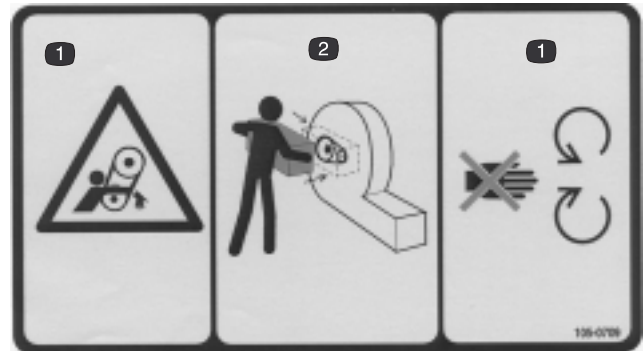

105-0709

1. Stay away from moving parts.
2. Do not operate with out belt shield in place.

Specifications

General Specifications

Fan Output	7000 CFM \pm 200 CFM 165 MPH \pm 20 MPH
Fan Speed	1173 RPM \pm 20 RPM @ 540 PTO Input
Outlet Area	100 square inches
Directional Control	Deflector chute for 180 degree diversion as standard. Rotational control of gate just behind 3-point hitch
Caster Wheels	Two 13 x 5.00-6 pneumatic rubber tires
Height Adjustment	0 – 1-1/2 by 1/2 in. increments
Turf Protection	16 inch long 4 inch diameter turf roller behind fan housing. 8 inch long 4 inch diameter turf roller under deflector. Beveled skid plate under deflector chute.
Ground Clearance	Determined by turf tractor 3-point hitch and caster wheels
Fan	.250 HRPO plate Radial design with 8 blades Outer diameter 27 inches \pm .5 inch Width 8 1/2 inches \pm 1-1/4 inch Weight 98 lbs. \pm 2 lbs.
Fan Housing	Split house – upper housing and lower housing Upper housing – 12 ga. HRPO front and rear plates flanged at separation seam with 12 ga. HRPO rolled and flanged blower band with increasing radius from cutoff point Lower housing – 10 ga. HRPO front and rear plates flanged at separation seam with 12 ga. HRPO roller and flanged blower band with increasing radius to exhaust Inside housing clearance 9-1/4 inches \pm 1-1/4 inch
Drive	Belt drive 4-5VX Power source: 30 PTO HP +1-3 HP turf tractor with 3-point hitch and 540 PTO Drive ratio: .460:1 Love joy torsion type belt tightener
Mounting:	Category one or two, three-point hitch on any tractor in the 30 PTO HP range with a three-point hitch and 540 PTO
Weight:	475 lbs.

Note: Specifications and design subject to change without notice.

Optional Equipment

Drive Line CE Kit

Part No. 105-0710

Setup

Note: Use this chart as a checklist to ensure that all parts have been received. Without these parts, total setup cannot be completed.

Description	Qty.	Use
Castor wheel	2	Mount castor wheels to castor forks
Axle	2	
Washer	8	
Cotter pin	4	
Drive shaft	1	Mount drive shaft blower and tractor
Operator's Manual	1	Read before operating the machine.
Parts Catalog	1	
Registration card	1	Fill out and return to Toro.

Note: Determine the left and right sides of the machine from the normal operating position.

Ballast Requirements

⚠
Caution
⚠

Without the proper amount of ballast in the tires, the tractor may become unstable and cause bodily injury.

Make sure that the front of the tractor is equipped with the proper amount of ballast; refer to the tractor operator's manual for ballast requirements.

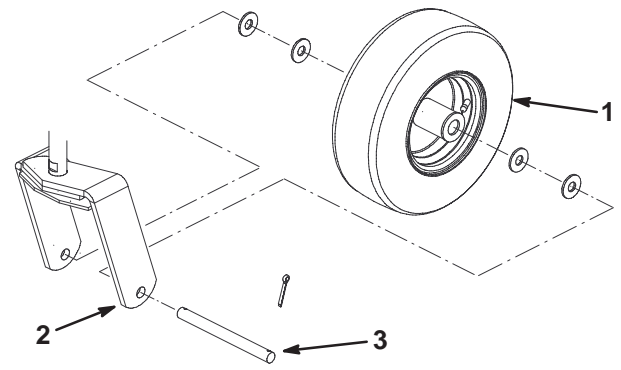

Figure 1

- 1. Wheel assembly
- 2. Castor fork
- 3. Axle

Install Castor Wheels

1. Install a castor wheel assembly between each castor fork with (4) washers, axle and (2) cotter pins (Fig. 1).

Note: Two washers to be positioned between each side of wheel and castor fork.

Connecting the Lower Link Arms

1. Position the blower on a flat, level surface.
2. Back the tractor squarely up to the blower until the lower link arms are aligned with the hitch pins.
3. Make sure that the PTO is disengaged.
4. Engage the parking brake, stop the engine, and remove the ignition key. Wait for the engine and all moving parts to stop before leaving the operator's seat on the tractor.
5. Insert the right and left lower link arms onto the hitch pins (Fig. 2).

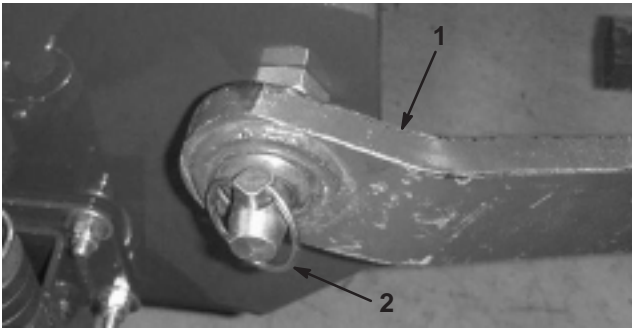

Figure 2

- 1. Lower link
- 2. Lynch pin

- 6. Secure the lower link arms to the hitch pins with the lynch pins (Fig. 2).

Connecting the Upper Link

- 1. Connect the upper link to the holes in the blower bracket and secure it with a clevis pin and lynch pin (Fig. 3).

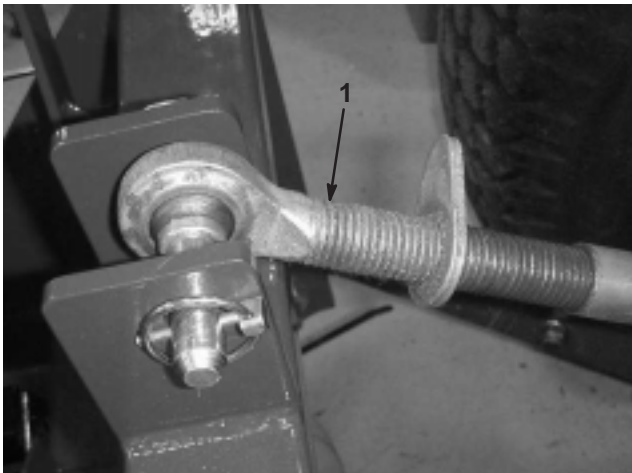

Figure 3

- 1. Upper link
- 2. Clevis pin
- 3. Lynch pin

- 2. Rotate the adjusting link to tighten the link. Do not overtighten to raise the back end of the blower off the ground.
- 3. Tighten the locknut to secure the upper link into position.

Adjusting the PTO Shaft Length

Important A long PTO shaft is supplied with the machine to accommodate large variations in the tractor's PTO and 3 point locations. For most tractors this shaft is too long and must be cut to the correct length or damage may result.

1. With the blower on a level surface, lower the blower until the input shaft is approximately the same height as the tractor PTO shaft. This is the shortest distance between the two shafts.
2. Measure the distance from the lock groove of the tractor PTO shaft to the lock groove of the blower input shaft. Record this dimension.
3. Fully collapse the PTO shaft and measure the distance between the lock pin collars. Record this dimension.
4. At it's shortest length, the two halves of the PTO shaft must have at least 1-1/2 inches (37 mm) of additional clearance to collapse (Fig. 4). If the dimension in step 2 is not at least 1-1/2 inches (37 mm) greater than the dimension in step 3, the PTO shaft is too long; proceed to step 5. If there is enough clearance to allow the PTO shaft to collapse, proceed to step 10.

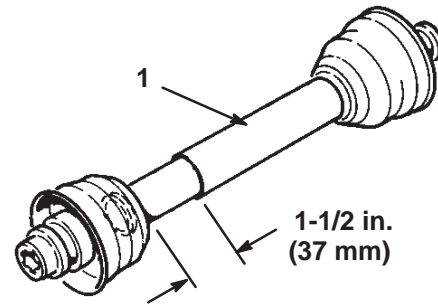

Figure 4

- 1. PTO shaft

5. Use the following calculation to establish how much shorter the shaft must be, when connected, to ensure a clearance of 1-1/2 inches (37 mm):
 - A. Subtract the dimension recorded in step 3 from the dimension recorded in step 2. Record this dimension.
 - B. Subtract the result in step 5A from 1-1/2 inches (37 mm). The PTO shaft must be shortened by this amount.
6. Using a hacksaw, cut the guards and the steel tubes shorter by the calculated length. Cut both halves of the PTO shaft.
7. Deburr the ends of the steel tubes internally and externally.

8. Remove all debris from the tube sections.
9. Grease the steel tubes liberally.
10. Assemble the PTO shaft and secure it to the blower and tractor.
11. Measure the shaft. If it is not at least 1-1/2 inches (37 mm), repeat the procedure.
12. Raise the blower to the highest position. There must be at least 3 inches (75 mm) of overlap of the halves. Adjust the 3 point lift stop, if necessary; refer to Adjusting the 3 Point Lift Stop, page 9.

Connecting the PTO Shaft

1. Connect the PTO shaft to the blower input shaft.
2. Connect the PTO shaft to the rear tractor PTO shaft.
3. Slide the PTO shaft forward as far as it will go.
4. Depress the pin to secure the PTO shaft in place. Slide the PTO shaft back and forth to make sure it is properly locked.

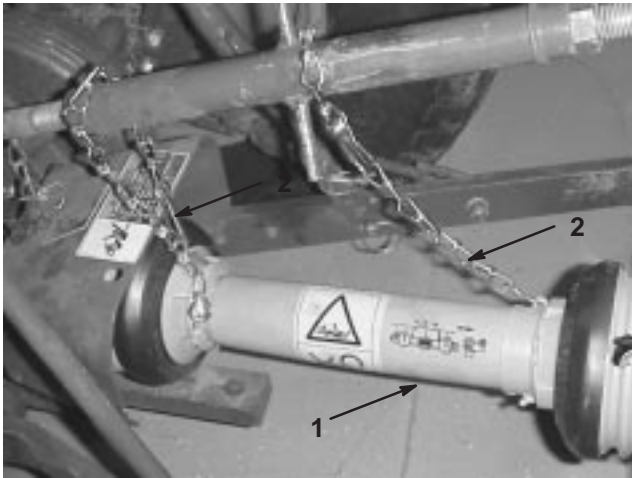

Figure 5

1. PTO shaft
2. Safety chains

5. Connect the shield safety chains from the powershaft sections to the welded clips on the link arms or to the PTO shields (Fig. 5). Make sure that the chains remain slack when the blower is raised or lowered.



Caution



If shield chains are not connected, they could rotate during operation and cause bodily injury.

Keep all PTO shields in place and connect the shield chains to the link arms or PTO shields.

Adjusting the Sway Links

Adjust the sway links on the lower draft arms of the 3-point hitch to minimize side-to-side sway to a maximum of 1 inch (25 mm) on each side.

1. Adjust the lower links inboard until they contact the blower mounting plates (Fig. 6). This will reduce the stress on the pins. If the tractor has sway chains instead of sway links, it is recommended that washers be installed between the lower link arm and lynch pin to reduce the over hung load on the lift pins.

Note: Refer to the tractor operator's manual for additional installation and adjustment procedures.

2. Turn the adjustable link body (if provided) to raise or lower the link arm until the blower is leveled side-to-side.



Figure 6

1. Sway link
2. Link body

Adjusting the 3 Point Lift Stop

Adjust and set the 3 point lift stop (Fig. 7) to provide approximately 4 in. (10 cm) ground clearance, when in the raised position, to minimize the PTO angle when raising the blower. For transporting or trailer loading/unloading,

the full lift range can be used as long as the PTO tubes do not slide apart. Operating the PTO in the fully raised position may damage the PTO or other components.

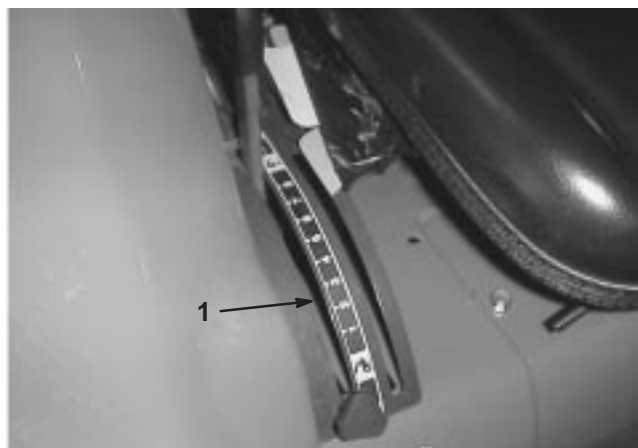

Figure 7

1. 3 point lift stop

Note: Refer to the tractor operator's manual for adjustment procedures.

Removing the Blower from the Tractor

1. Stop the vehicle on a level surface, not on a slope.
2. Disengage the PTO and engage the parking brake.
3. Stop the engine and remove the key from the ignition switch.

Before leaving the operator's seat on the tractor, wait for the engine and all moving parts to stop.

4. Disconnect the safety shield chains from the tractor PTO. Secure the end of the chain to the blower side of the PTO shaft to prevent the PTO shaft from coming apart.
5. Slowly lower the blower until the roller and castor wheels contact the ground.
6. Remove the lynch pin and top link pin securing the center link to the bracket.
7. Disconnect the powershaft from the tractor PTO shaft.
8. Slide the powershaft back and remove it from the tractor.
9. Remove the lynch pins and slide the lower link arms off of the hitch pins.

Greasing the Blower

Before the blower is operated, the PTO shaft must be greased to ensure proper lubricating characteristics; refer to Greasing the Blower in the Maintenance section; page 12. Failure to properly grease the unit will result in premature failure of critical parts.

Operation

Note: Determine the left and right sides of the machine from the normal operating position.

Operating Tips

Warning

Discharged air has considerable force and could cause injury or loss of footing.

- Stay away from the discharge opening when the machine is operating.
- Keep bystanders away from the discharge opening when the machine is running.

1. Start the tractor and run it at a low RPM.
2. Engage the PTO while the engine is at idle speed.
3. Increase the PTO speed to 1800 RPM.
4. Practice blowing material. It is advisable to blow the same direction the wind is blowing to prevent material from blowing back into the cleared area.

Adjusting Discharge Direction

The direction of the discharge opening can be changed from the side to the front by moving the control handle (Fig. 8).

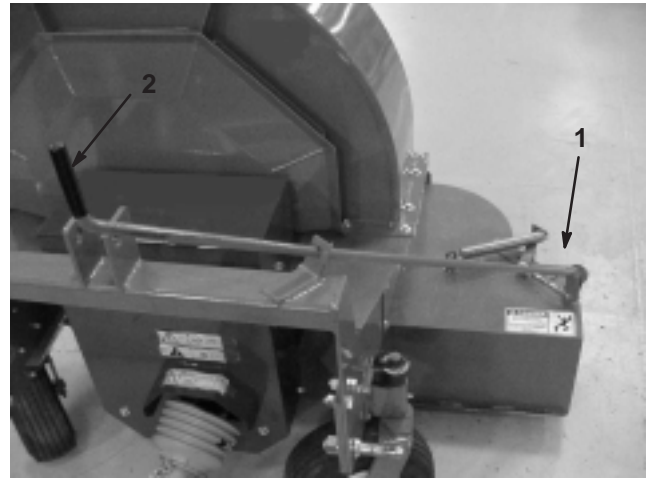

Figure 8

1. Discharge opening
2. Control handle

Maintenance

Note: Determine the left and right sides of the machine from the normal operating position.

Greasing the Blower

Fan Shaft Bearings

The (2) fan shaft bearings (Fig. 9) must be lubricated after every 8 hours of operation with a No. 2 Lithium-based grease.

Note: Remove belt cover to access rear fitting.



Figure 9

Castor Wheels

Under normal conditions, grease the (2) castor wheel pivot tubes (Fig. 10) after every 50 hours of use. Use a No. 2 Lithium-based grease.

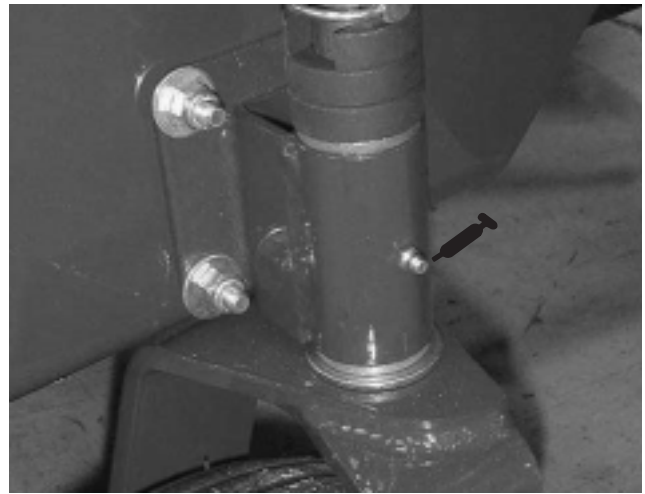

Figure 10

Drive Shaft

Under normal conditions, grease the (2) drive shaft fittings after every 100 hours of use (Fig. 11). Use a No. 2 Lithium-based grease.

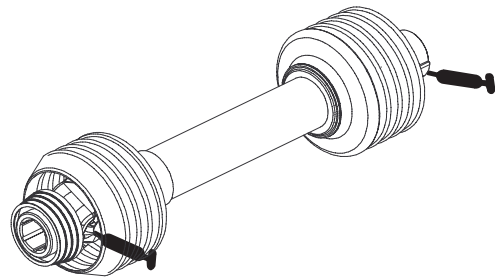

Figure 11

Adjusting the Blower Belt

Make sure belt is properly tensioned to ensure proper operation of the machine and unnecessary wear. Check belt frequently.

Note: Check/adjust the blower belt tension after the first 20 hours of operation.

1. Remove the capscrews, washers and nuts securing the belt guard to the blower housing (Fig. 12). Remove the guard.

Note: The drive shaft does not have to be disconnected to adjust the belt.



Figure 12

1. Belt guard

2. Remove capscrew and nut securing tensioner guide to blower frame (Fig. 13). Belt tension will be released when capscrew is removed.

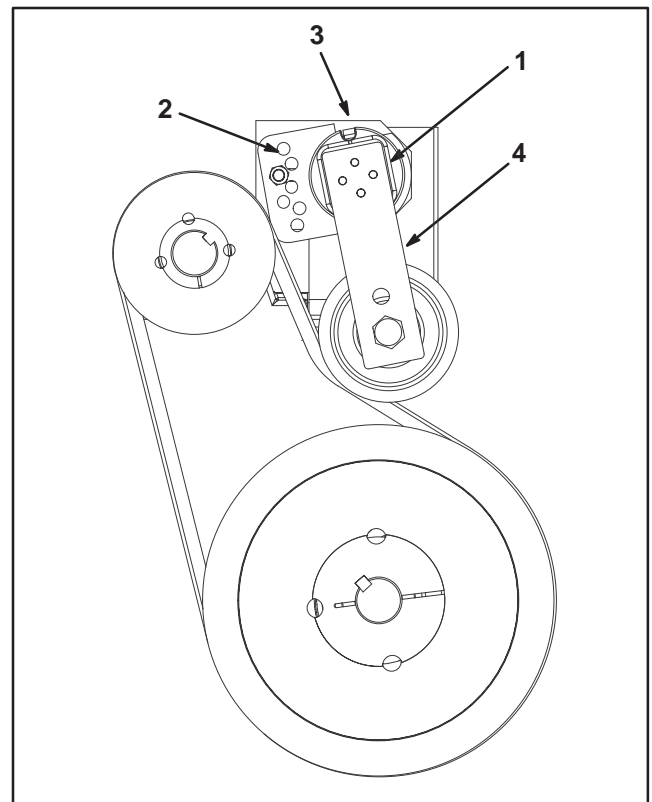

Figure 13

- | | |
|------------------------|----------------------|
| 1. Belt tensioner tube | 3. Capscrew location |
| 2. Tensioner guide | 4. Idler arm |

3. On back side of frame, loosen capscrew securing belt tensioner to frame.
4. Position a large wrench on tensioner. Rotate tensioner clockwise until decal is aligned with 15° on tensioner tube.
5. Insert capscrew into aligned guide holes and secure with nut. If holes are not exactly aligned, rotate guide to the next higher hole until aligned.
6. Tighten capscrew securing, on back side of frame to lock tensioner.
7. Install the belt guard to the blower housing with the capscrews, washers, and nuts.

Troubleshooting

Problem	Possible Causes	Corrective Action
There is excessive vibration.	<ol style="list-style-type: none">1. The bearing(s) on the fan shaft is damaged.2. Material is built up on the fan blades.3. The RPM of the PTO shaft is too fast.	<ol style="list-style-type: none">1. Replace the bearings.2. Clean out any build up on the inside of the housing.3. Reduce the PTO speed to 540 RPM.
There is lack of adequate air flow.	<ol style="list-style-type: none">1. The air slots are clogged with debris.2. The RPM on the tractor is too slow.3. The throttle on the tractor engine is too low.	<ol style="list-style-type: none">1. Clean out any debris from the slots.2. Increase the PTO speed to 540 RPM.3. Make any necessary repairs to bring the tractor speed up to normal.

Storage

1. Thoroughly clean the blower. The fan housing should be free of dirt, leaves, and debris.
2. Lubricate all grease fittings. Wipe off any excess lubricant.
3. Place a light coat of grease on the splines of the PTO shaft.
4. Tighten all fasteners.



The Toro General Commercial Products Warranty

A Two-Year Limited Warranty

Conditions and Products Covered

The Toro Company and its affiliate, Toro Warranty Company, pursuant to an agreement between them, jointly warrant your 1996 or newer Toro Commercial Product ("Product") purchased after January 1, 1997, to be free from defects in materials or workmanship for two years or 1500 operational hours*, whichever occurs first. Where a warrantable condition exists, we will repair the Product at no cost to you including diagnosis, labor, parts, and transportation. This warranty begins on the date the Product is delivered to the original retail purchaser.

* Product equipped with hour meter

Instructions for Obtaining Warranty Service

You are responsible for notifying the Commercial Products Distributor or Authorized Commercial Products Dealer from whom you purchased the Product as soon as you believe a warrantable condition exists.

If you need help locating a Commercial Products Distributor or Authorized Dealer, or if you have questions regarding your warranty rights or responsibilities, you may contact us at:

Toro Commercial Products Service Department
Toro Warranty Company
8111 Lyndale Avenue South
Bloomington, MN 55420-1196
952-888-8801 or 800-982-2740
E-mail: commercial.service@toro.com

Owner Responsibilities

As the Product owner, you are responsible for required maintenance and adjustments stated in your operator's manual. Failure to perform required maintenance and adjustments can be grounds for disallowing a warranty claim.

Items and Conditions Not Covered

Not all product failures or malfunctions that occur during the warranty period are defects in materials or workmanship. This express warranty does not cover the following:

- Product failures which result from the use of non-Toro replacement parts, or from installation and use of add-on, modified, or unapproved accessories
- Product failures which result from failure to perform required maintenance and/or adjustments
- Product failures which result from operating the Product in an abusive, negligent or reckless manner
- Parts subject to consumption through use unless found to be defective. Examples of parts which are consumed, or used up, during normal Product operation include, but are not limited to, blades, reels, bedknives, tines, spark plugs, castor wheels, tires, filters, belts, etc.

Countries Other than the United States or Canada

Customers who have purchased Toro products exported from the United States or Canada should contact their Toro Distributor (Dealer) to obtain guarantee policies for your country, province, or state. If for any reason you are dissatisfied with your Distributor's service or have difficulty obtaining guarantee information, contact the Toro importer. If all other remedies fail, you may contact us at Toro Warranty Company.

- Failures caused by outside influence. Items considered to be outside influence include, but are not limited to, weather, storage practices, contamination, use of unapproved coolants, lubricants, additives, or chemicals, etc.
- Normal "wear and tear" items. Normal "wear and tear" includes, but is not limited to, damage to seats due to wear or abrasion, worn painted surfaces, scratched decals or windows, etc.

Parts

Parts scheduled for replacement as required maintenance are warranted for the period of time up to the scheduled replacement time for that part.

Parts replaced under this warranty become the property of Toro. Toro will make the final decision whether to repair any existing part or assembly or replace it. Toro may use factory remanufactured parts rather than new parts for some warranty repairs.

General Conditions

Repair by an Authorized Toro Distributor or Dealer is your sole remedy under this warranty.

Neither The Toro Company nor Toro Warranty Company is liable for indirect, incidental or consequential damages in connection with the use of the Toro Products covered by this warranty, including any cost or expense of providing substitute equipment or service during reasonable periods of malfunction or non-use pending completion of repairs under this warranty. Except for the Emissions warranty referenced below, if applicable, there is no other express warranty. All implied warranties of merchantability and fitness for use are limited to the duration of this express warranty.

Some states do not allow exclusions of incidental or consequential damages, or limitations on how long an implied warranty lasts, so the above exclusions and limitations may not apply to you.

This warranty gives you specific legal rights, and you may also have other rights which vary from state to state.

Note regarding engine warranty: The Emissions Control System on your Product may be covered by a separate warranty meeting requirements established by the U.S. Environmental Protection Agency (EPA) and/or the California Air Resources Board (CARB). The hour limitations set forth above do not apply to the Emissions Control System Warranty. Refer to the Engine Emission Control Warranty Statement printed in your operator's manual or contained in the engine manufacturer's documentation for details.