



Count on it.

Parts Catalog

Flex-Force Power System™
60V MAX 36cm Lawn Mower

Model No. 21836—Serial No. 321000001 and Up



Ordering Replacement Parts

To order replacement parts, please supply the part number, the quantity, and the description of each part desired.

Understanding Reference Numbers

Each identified part in an illustration has a reference number. The reference number for a part also appears in the parts list, along with other information about the part.

This catalog uses two special reference number formats, one to indicate parts in a service assembly and another to indicate the quantity of a given part in an illustration.

Service Assembly Reference Numbers

Parts in service assemblies have reference numbers in the form a:b. The a represents the reference number of the entire service assembly and the b represents a sequential number unique to each part within the service assembly.

For example, a wheel assembly might be identified by reference number 6, the tire by 6:1, the valve by 6:2, and the wheel by 6:3. When you order the assembly identified by reference number 6, you receive all parts identified by reference numbers 6:1, 6:2, and 6:3. However, you may also order any part individually. Reference numbers of this type appear in illustration and in parts lists.

Reference Numbers Indicating Quantity

In an illustration, if a reference number indicates more than one part, the reference number has the form nX y. The n represents the quantity of the part, the X is the multiplication symbol, and the y represents the reference number.

For example, in an illustration, the reference number 2X 37 means that two of the parts identified by reference number 37 are indicated.

Contents

Frame Assembly.....	4
Grass Box Assembly No. 134-6957	6
Battery Interface Assembly No. 134-4105	8
Motor, Battery and Blade Assembly	10
Traction and Height-of-Cut Assembly	12
Wheel Assembly No. 134-4363	14
Handle Assembly	16
Control Arm Assembly No. 134-5240	18
Attachments and Accessories	20

Frame Assembly

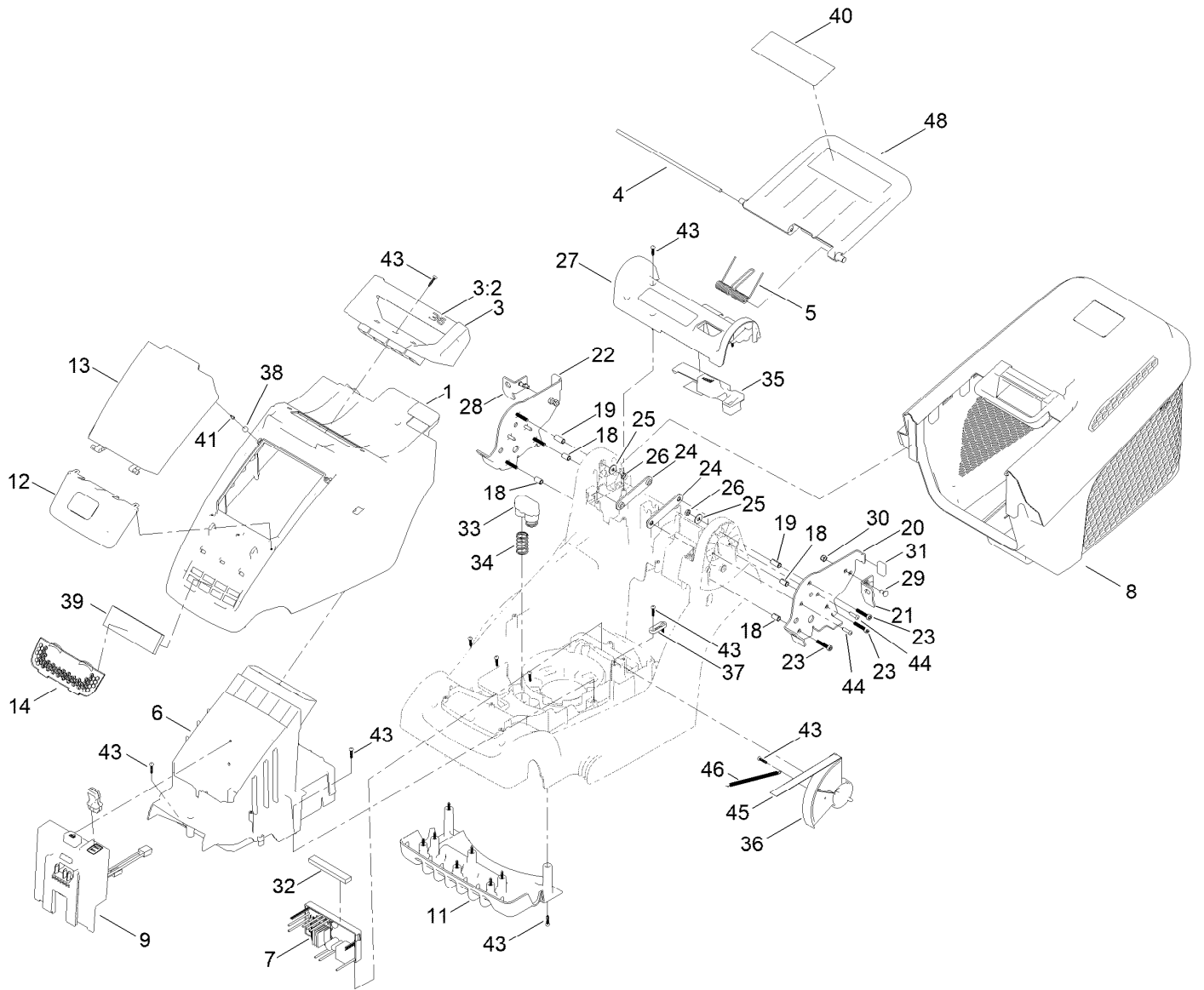

Frame Assembly (continued)

<i>Ref.</i>	<i>Part Number</i>	<i>Qty.</i>	<i>Description</i>	<i>Ref.</i>	<i>Part Number</i>	<i>Qty.</i>	<i>Description</i>
1	134-5434	1	Top Cover	26	134-6376	1	Nut-Hex
3	134-5311	1	Carry Handle	27	134-4113	1	HOC Cover
3:2	134-5410	1	Artwork - 36CM	28	134-5177	1	Bracket, V-Stow, Right
4	134-5288	1	Rod, Rear Flap	29	134-5235	4	Bolt-Carriage
5	134-4037	1	Spring, Rear Deflector	30	134-5234	4	Nut-Hex
6	134-4120	1	Battery Holder	31	134-4434	2	Rubber Foot-V-Stow
7	134-6381	1	Driver-Motor, 36CM	32	134-5432	1	Filter, Air-Control Board
8	134-6957	1	Grass Box ASM	33	134-5282	1	Battery Spring Cover
9	134-4105	1	Battery Interface Assembly	34	134-4371	2	Spring, Battery Eject
11	134-4137	1	Front Fins	35	134-6378	1	HOC Button, 36CM
12	134-5316	1	Battery Door Lower, Printed	36	134-4099	1	HOC Dial
13	134-5313	1	Battery Door, Printed	37	134-6367	1	Tab
14	134-4322	1	Air Inlet Grill-Toro	38	114-5896	2	Magnet
18	134-6369	4	Bush	39	134-4341	1	Inner Filter-Foam
19	134-6374	2	Bush	40	134-4550	1	Decal-Safety, 60V
20	134-4396	1	Mount Plate, Handlebar, Left	41	134-4375	1	Screw-Txph
21	134-5175	1	Bracket, V-Stow, Left	43	134-7001	24	Screw-T
22	134-4398	1	Mount Plate, Handlebar, Right	44	134-5431	4	Screw-T
23	134-6371	6	Screw-Tsh	45	134-5436	1	Decal - HOC
24	134-6370	2	Brace-Bar	46	134-6356	1	Spring
25	134-5439	2	Washer-Plain	48	134-5433	1	Rear Deflector, Toro

Grass Box Assembly No. 134-6957

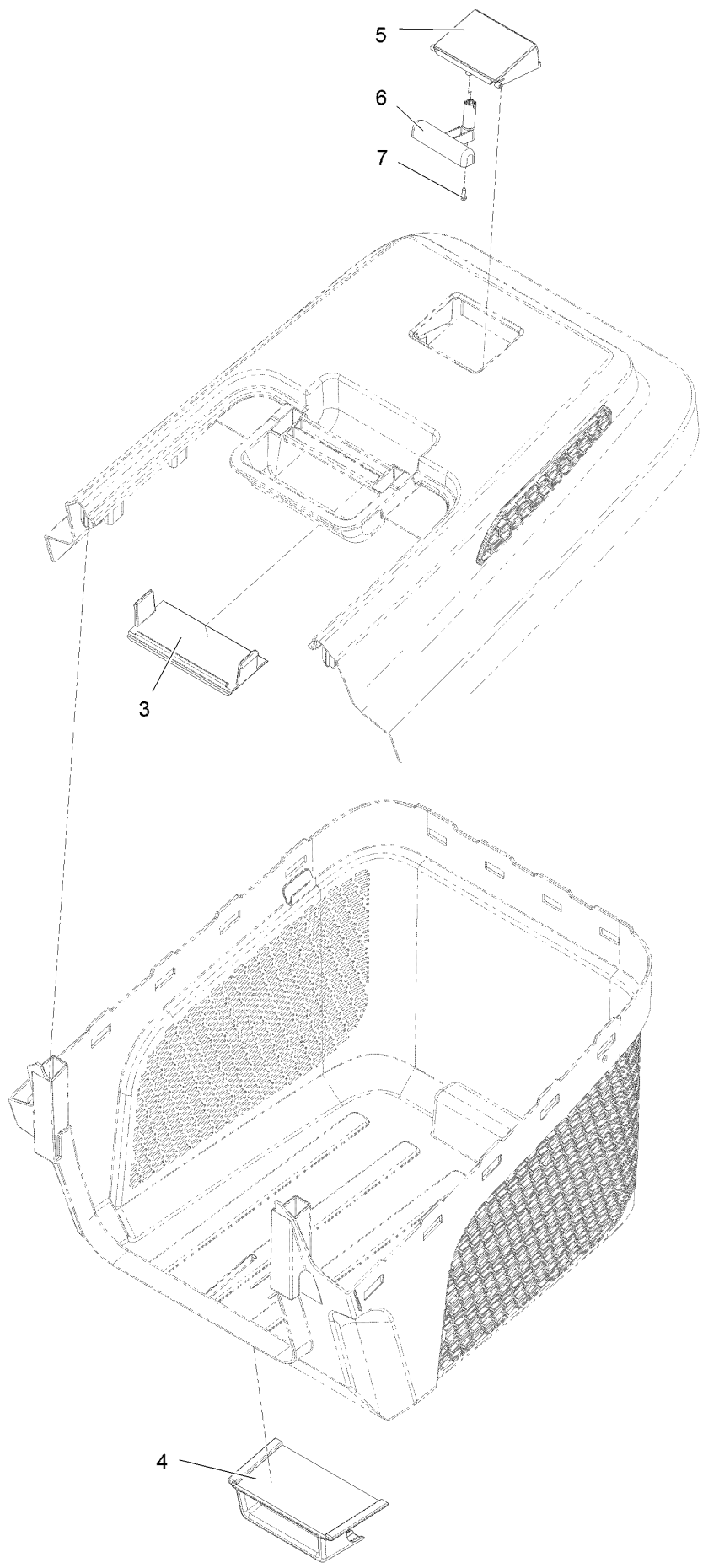

Grass Box Assembly No. 134-6957 (continued)

<i>Ref.</i>	<i>Part Number</i>	<i>Qty.</i>	<i>Description</i>	<i>Ref.</i>	<i>Part Number</i>	<i>Qty.</i>	<i>Description</i>
3	134-4141	1	Grass Box Handle Infill	6	134-5430	1	Counter Weight
4	134-4388	1	Grass Box Hook	7	134-5435	1	Screw-T
5	134-4143	1	Grass Box Full Indicator				

Battery Interface Assembly No. 134-4105

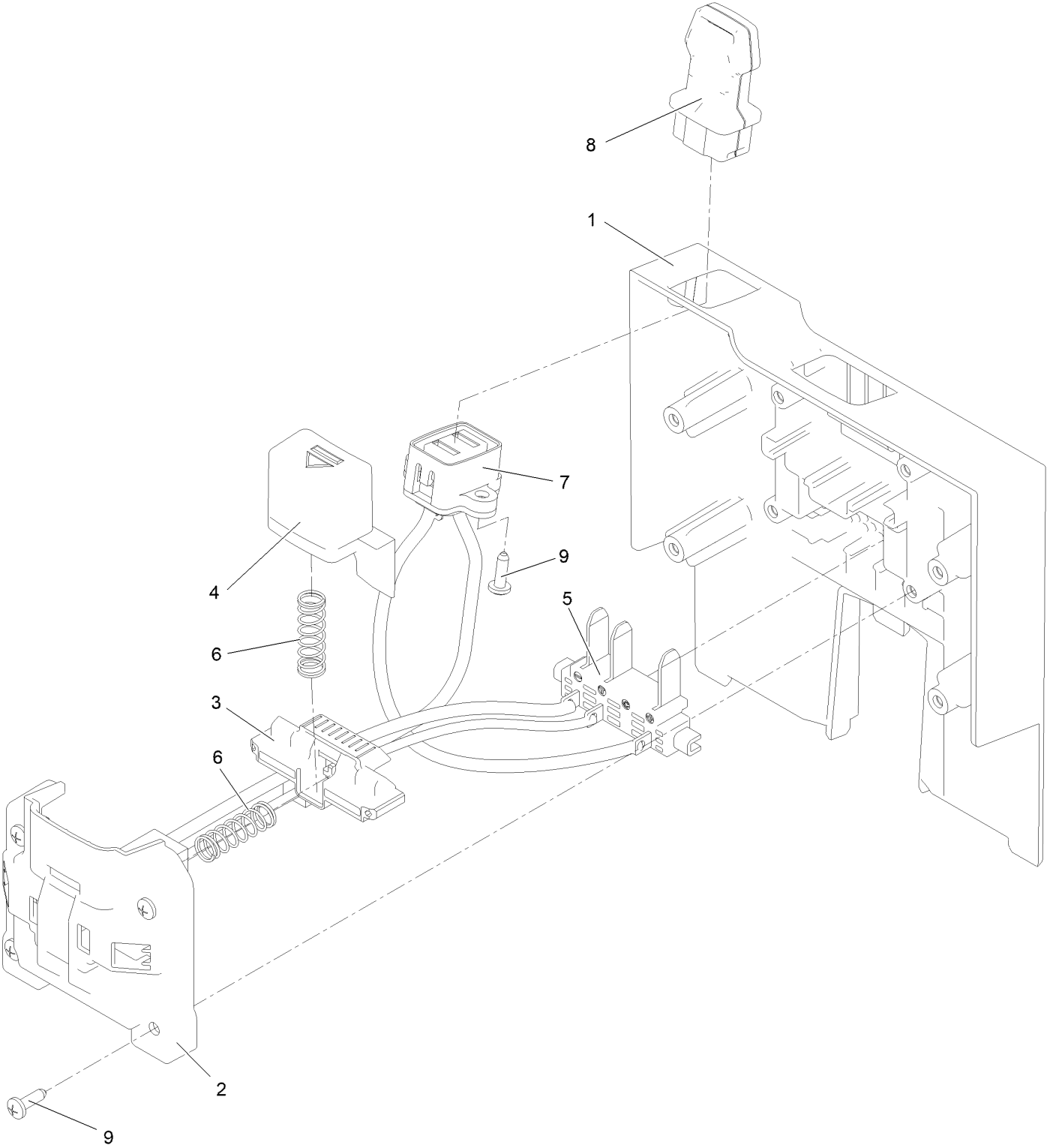

Battery Interface Assembly No. 134-4105 (continued)

<i>Ref.</i>	<i>Part Number</i>	<i>Qty.</i>	<i>Description</i>	<i>Ref.</i>	<i>Part Number</i>	<i>Qty.</i>	<i>Description</i>
1	134-4104	1	Battery Interface	6	134-5362	2	Spring, Battery Latch
2	134-4374	1	Battery Contact Cover	7	134-4386	1	Power Socket
3	134-5359	1	Latch, Battery	8	134-4385	1	Power Key
4	134-4373	1	Battery Button	9	134-5361	6	Screw-T
5	134-5360	1	Connection Terminal, Battery				

Motor, Battery and Blade Assembly

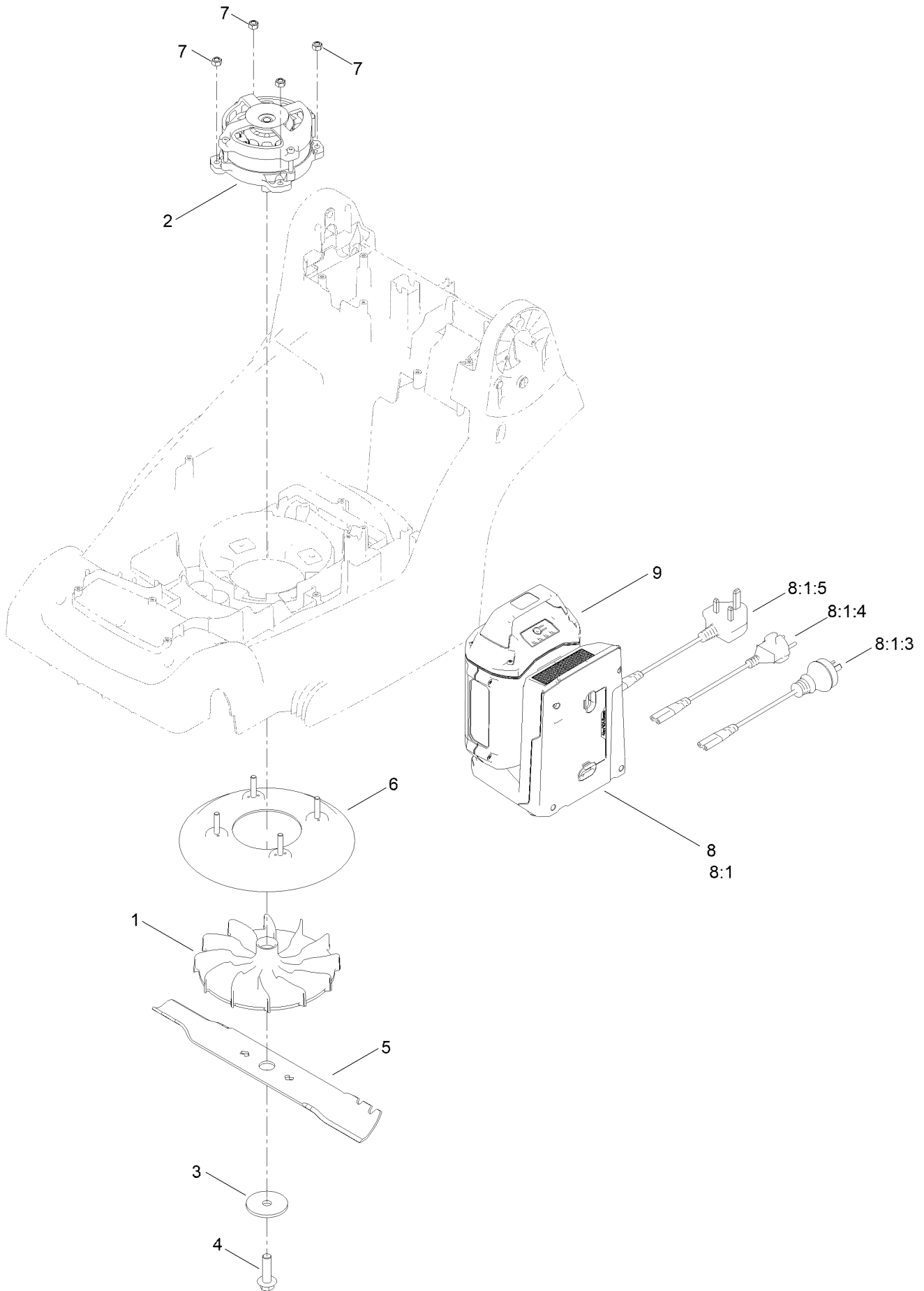

Motor, Battery and Blade Assembly (continued)

<i>Ref.</i>	<i>Part Number</i>	<i>Qty.</i>	<i>Description</i>	<i>Ref.</i>	<i>Part Number</i>	<i>Qty.</i>	<i>Description</i>
1	134-4381	1	Blade Carrier	7	134-4467	4	Nut-Hex
2	134-4106	1	Motor, Brushless, 60V, 600W	8	139-8291	1	60V Charger CE
3	134-4382	1	Blade Washer	8:1		1	60V Charger 2 Amp ●
4	134-4383	1	Blade Bolt	8:1:3	140-2192	1	Cord-Charger, Au/Nz
5	134-5212	1	Blade, Mulch, 36CM	8:1:4	140-2193	1	Cord-Charger, CE
6	134-4133	1	Blade Cover	8:1:5	140-2194	1	Cord-Charger, Uk
				9	81825	1	60V 2.5 Ah Battery CE

● Not serviced separately

Traction and Height-of-Cut Assembly

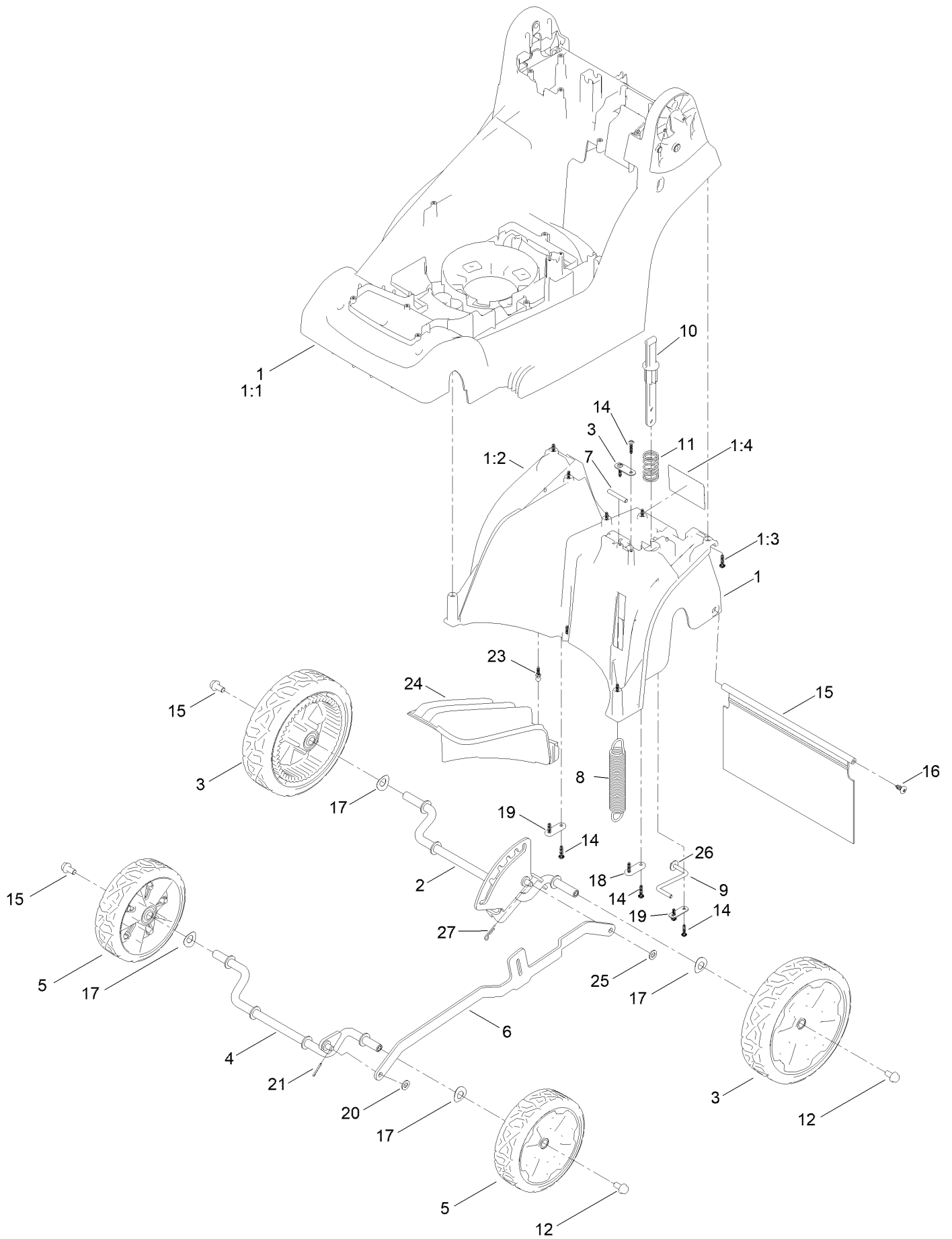

Traction and Height-of-Cut Assembly (continued)

<i>Ref.</i>	<i>Part Number</i>	<i>Qty.</i>	<i>Description</i>	<i>Ref.</i>	<i>Part Number</i>	<i>Qty.</i>	<i>Description</i>
1	134-6912	1	Deck, Glued (36)	11	134-4088	1	Spring, HOC Button
1:1	134-4111	1	Deck-36CM	12	134-4358	4	Bolt-HF
1:2	134-4117	1	36CM 4 Wheel Rear Chassis Moulding	14	134-7001	9	Screw-T
1:3	134-4415	8	Screw, T20	15	134-4138	1	Shield-Trailing, 36CM
1:4	134-5099	1	Decal - Safety	16	117-1092	2	Screw-PTH
2	134-4418	1	Rear Axle Frame, Assy, Wheel	17	134-4457	4	Washer-Wave
3	134-4363	2	Wheel-Rear Assembly	18	134-4411	2	Axle Plate
4	134-4130	1	Front Axle, Assembly	19	134-4394	2	Axle Plate, Small
5	134-4307	2	Wheel-Toro Front Assembly	20	106-4756	1	Washer-Plain
6	134-4129	1	Con-Rod, 4 Wheel	21	134-4454	1	Cotter Pin
7	134-4096	1	Bar, Spring Mount	23	134-5294	2	Pin, Retaining, Mulch Plug
8	134-4092	1	HOC Spring, 4 Wheel	24	134-5293	1	Mulch Plug
9	134-4321	1	HOC Wire	25	134-5439	1	Washer-Plain
10	134-4319	1	HOC Button Plunger	26	134-5440	1	Washer
				27	134-6827	1	Cotter Pin

Wheel Assembly No. 134-4363

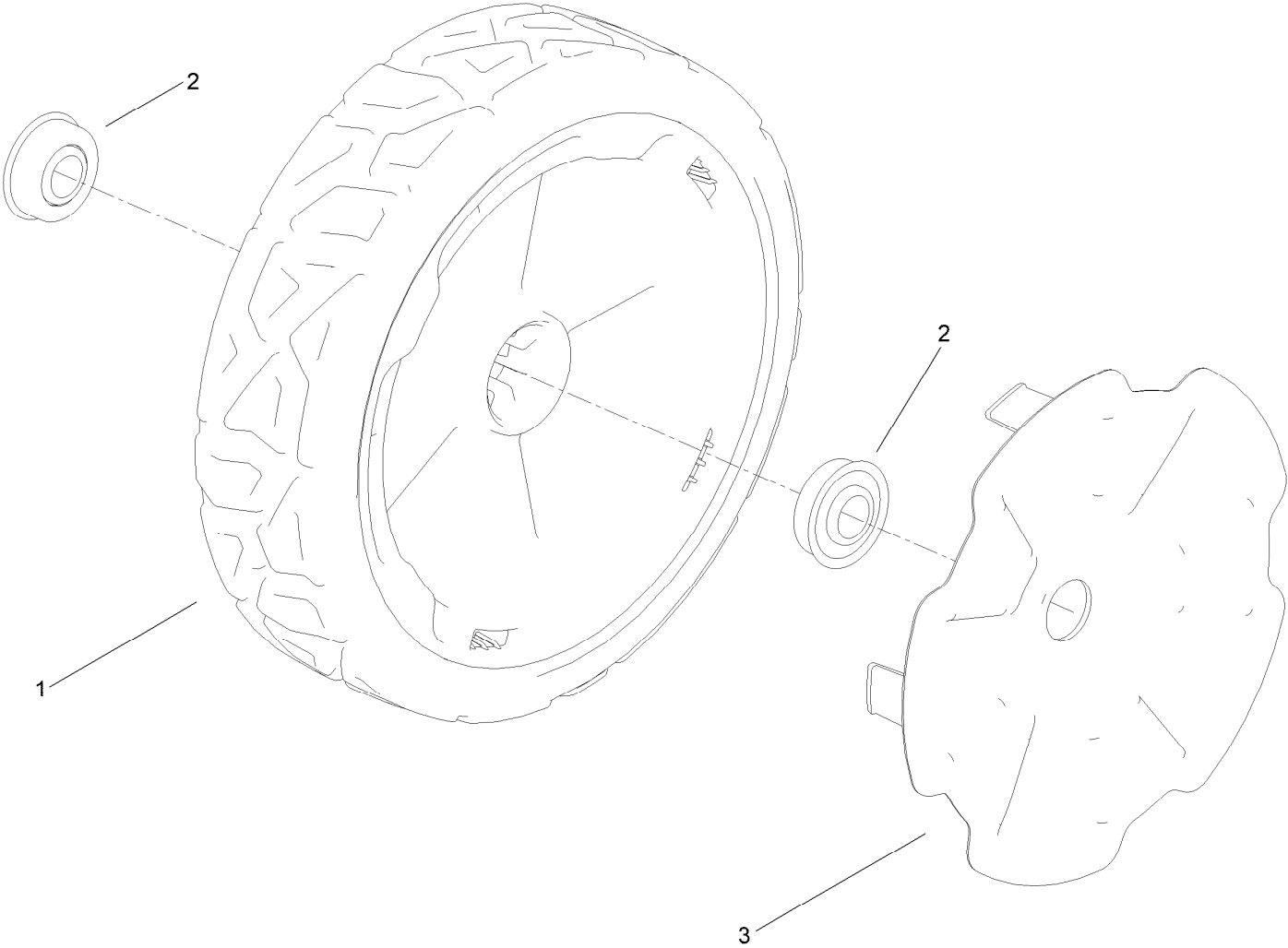

Wheel Assembly No. 134-4363 (continued)

<i>Ref.</i>	<i>Part Number</i>	<i>Qty.</i>	<i>Description</i>
1	134-4404	1	Wheel-Toro Rear
2	134-4377	2	Bearing
3	134-4366	1	Rear Wheel Trim - Toro

Handle Assembly

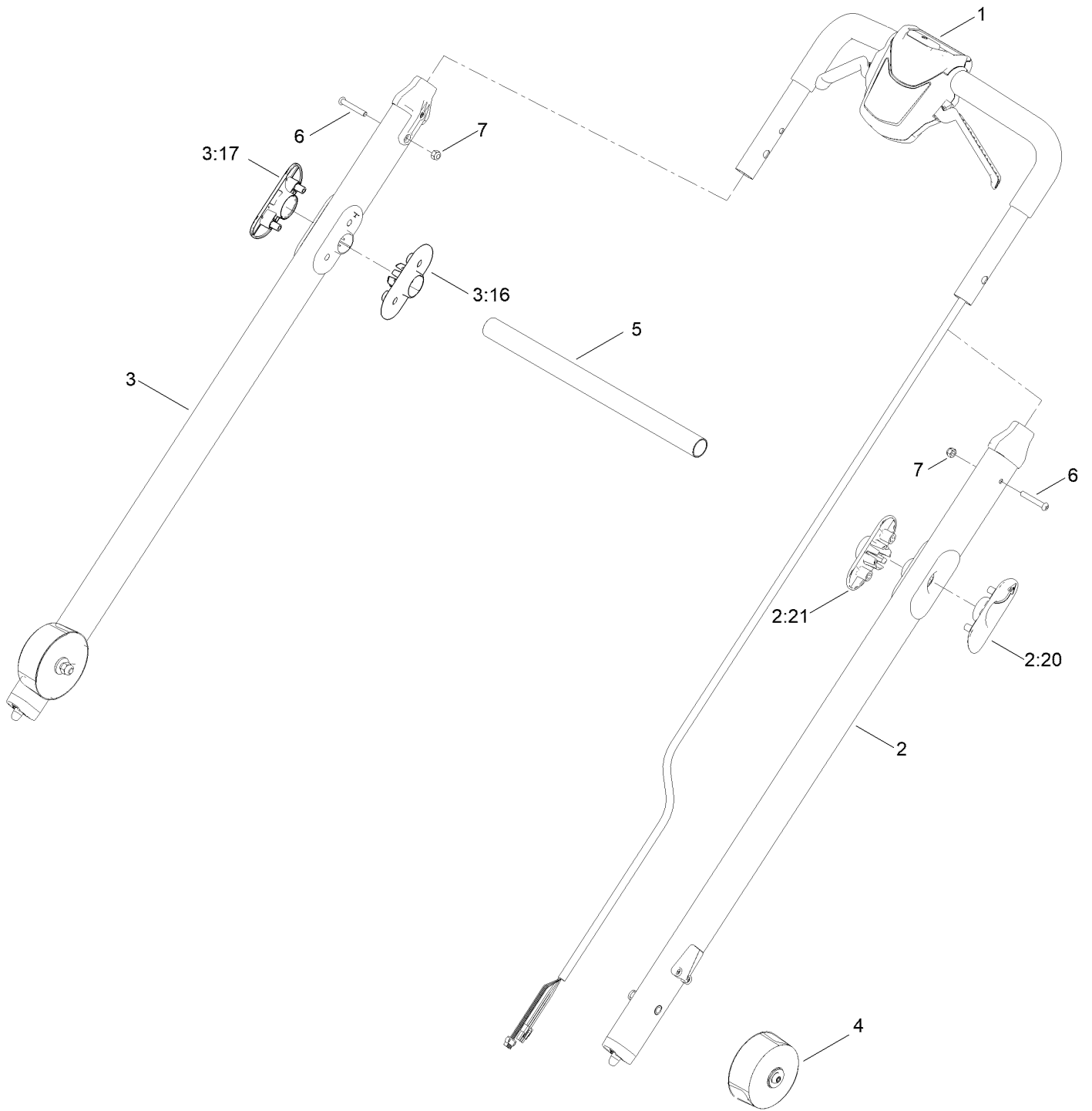

Handle Assembly (continued)

<i>Ref.</i>	<i>Part Number</i>	<i>Qty.</i>	<i>Description</i>	<i>Ref.</i>	<i>Part Number</i>	<i>Qty.</i>	<i>Description</i>
1	134-5240	1	Handlebar Control ASM, 36CM	3:16	134-4487	1	Spring, Lock Pin, Handle
2	134-6353	1	Handlebar ASM, LH	3:17	134-5309	1	Handlebar Brace, Outer
2:20	134-5308	1	Handlebar Brace - Inner	4	134-4416	2	Handlebar End Cap
2:21	134-5309	1	Handlebar Brace, Outer	5	134-5239	1	Brace, Handlebar Release
3	134-6354	1	Handlebar ASM, RH	6	134-5206	2	Bolt-P
				7	134-5207	2	Nut, M6, Nyloc

Control Arm Assembly No. 134-5240

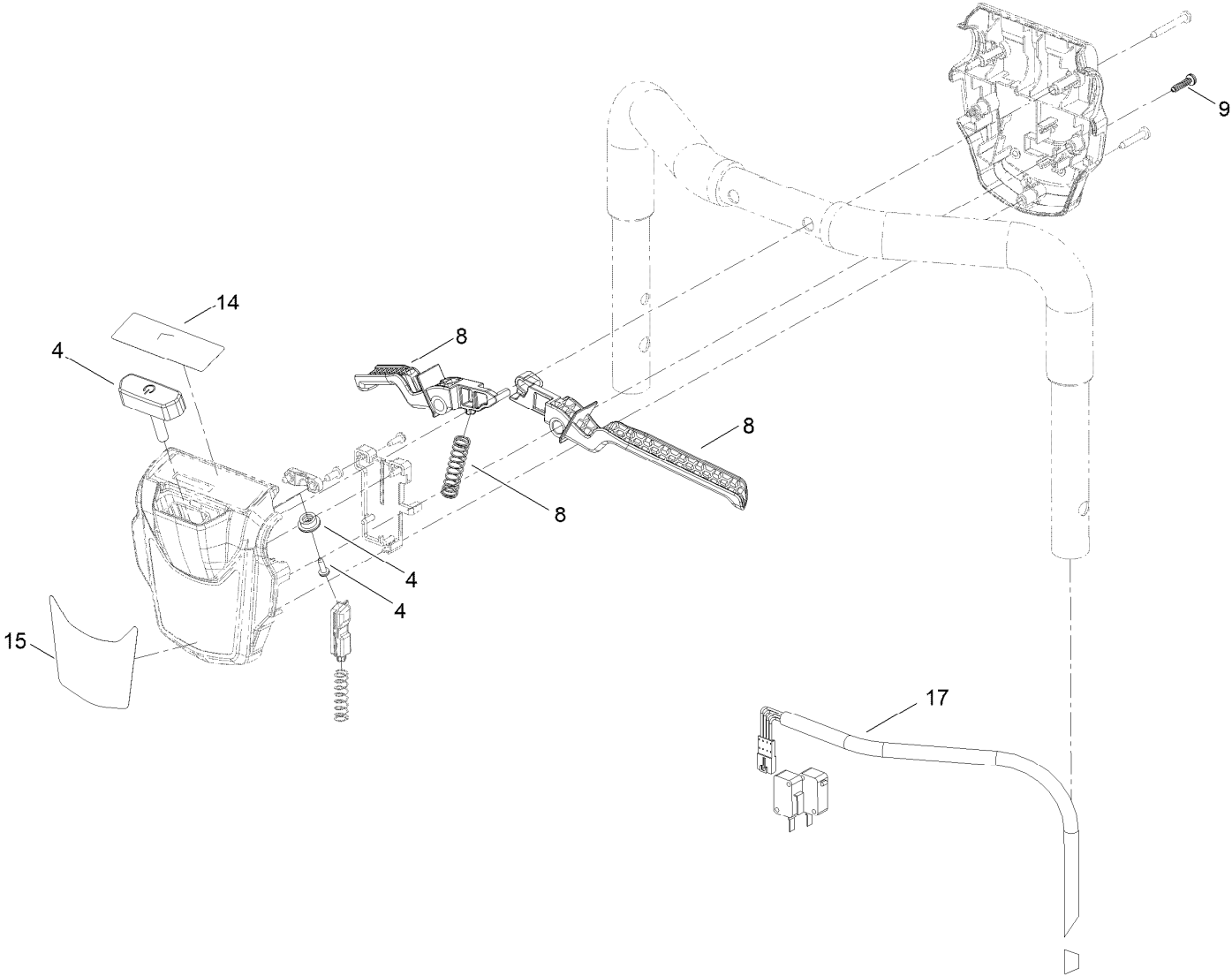

Control Arm Assembly No. 134-5240 (continued)

<i>Ref.</i>	<i>Part Number</i>	<i>Qty.</i>	<i>Description</i>	<i>Ref.</i>	<i>Part Number</i>	<i>Qty.</i>	<i>Description</i>
4	134-6903	1	Top Button Kit	14	134-5297	1	Decal - Boost Key Mat
8	134-6905	1	Upper Lever Kit (36)	15	134-2697	1	Decal - Volta Handle
9	134-5205	2	Screw-T	17	134-5455	1	Wiring Loom, Push

Attachments and Accessories

For 21836 Flex-Force Power System 60V MAX 36cm Lawn Mower

Product Name	Model/Part
60V 2.5AH BATTERY CE HAYTER	CODE102A
60V 4.0AH BATTERY CE HAYTER	CODE104A
60V 6.0AH BATTERY CE HAYTER	CODE106A
60V 7.5AH BATTERY CE HAYTER	CODE107A
60V BATTERY CHARGER 2 AMP CE HAYTER	CODE120A
60V FAST CHARGER, CE HAYTER	CODE121A

Notes:

Notes:

Notes:



Count on it.